

OPERATOR'S MANUAL

CRAFTSMAN®

19.2 VOLT CORDLESS JIG SAW

Variable Speed / Orbital

Model No.
315.114280

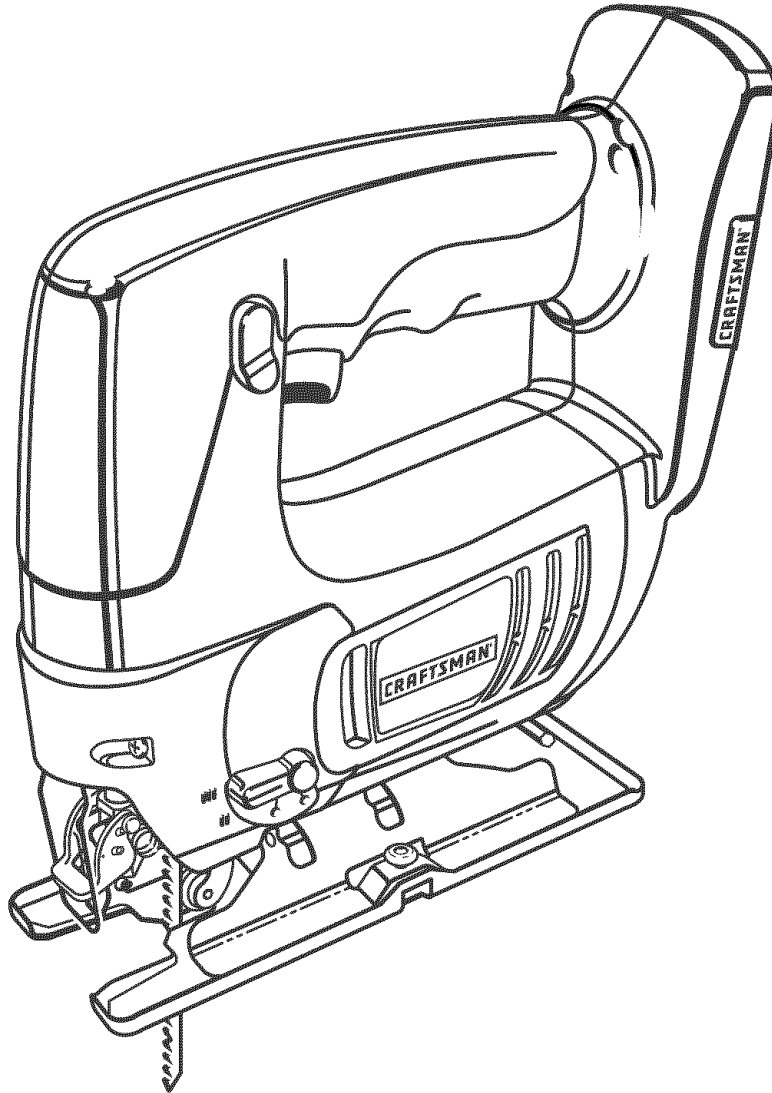

WARNING: To reduce the risk of injury, the user must read and understand the operator's manual before using this product.

Use jig saw only with recommended Craftsman battery pack and charger (both sold separately)

Customer Help Line: 1-800-932-3188

Sears, Roebuck and Co., 3333 Beverly Rd., Hoffman Estates, IL 60179 USA
Visit the Craftsman web page: www.sears.com/craftsman



TABLE OF CONTENTS

■ Warranty.....	2
■ Introduction.....	2
■ General Safety Rules	3-4
■ Specific Safety Rules	4
■ Safety Rules For Charger.....	5
■ Symbols	6-7
■ Features	8-9
■ Assembly	9
■ Operation	10-15
■ Maintenance	16
■ Accessories	16
■ Exploded View and Repair Parts List.....	18
■ Parts Ordering / Service	Back Page

WARRANTY

ONE YEAR FULL WARRANTY ON CRAFTSMAN TOOL

If this Craftsman tool fails to give complete satisfaction within one year from date of purchase, **RETURN IT TO THE NEAREST SEARS STORE OR SEARS PARTS & REPAIR CENTER IN THE UNITED STATES**, and Sears will replace it, free of charge.

If this Craftsman tool is used for commercial or rental purposes, this warranty applies for only 90 days from the date of purchase.

This warranty gives you specific legal rights, and you may also have other rights which vary from state to state.

Sears, Roebuck and Co., Dept. 817WA, Hoffman Estates, IL 60179

INTRODUCTION

This tool has many features for making its use more pleasant and enjoyable. Safety, performance, and dependability have been given top priority in the design of this product making it easy to maintain and operate.

GENERAL SAFETY RULES

⚠ WARNING! READ AND UNDERSTAND ALL INSTRUCTIONS. Failure to follow all instructions listed below, may result in electric shock, fire and/or serious personal injury.

SAVE THESE INSTRUCTIONS

WORK AREA

- **Keep your work area clean and well lit.** Cluttered benches and dark areas invite accidents.
- **Do not operate power tools in explosive atmospheres, such as in the presence of flammable liquids, gases, or dust.** Power tools create sparks which may ignite the dust or fumes.
- **Keep bystanders, children, and visitors away while operating a power tool.** Distractions can cause you to lose control.

ELECTRICAL SAFETY

- **A battery operated tool with integral batteries or a separate battery pack must be recharged only with the specified charger for the battery.** A charger that may be suitable for one type of battery may create a risk of fire when used with another battery.
- **Use battery operated tool only with specifically designated battery pack.** Use of any other batteries may create a risk of fire.
- **Use battery only with charger listed.**

MODEL	BATTERY PACK	CHARGER
315.114280	ITEM NO. 9 11375 (130139020)	ITEM NO. 9 11041 (1425301)

- **Do not abuse the cord. Never use the cord to carry the charger. Keep cord away from heat, oil, sharp edges, or moving parts. Replace damaged cords immediately.** Damaged cords may create a fire.

PERSONAL SAFETY

- **Stay alert, watch what you are doing and use common sense when operating a power tool. Do not use tool while tired or under the influence of drugs, alcohol, or medication.** A moment of inattention while operating power tools may result in serious personal injury.
- **Dress properly. Do not wear loose clothing or jewelry. Contain long hair. Keep your hair, clothing, and gloves away from moving parts.** Loose clothes, jewelry, or long hair can be caught in moving parts.
- **Avoid accidental starting. Be sure switch is in the locked or off position before inserting battery pack.** Carrying tools with your finger on the switch or inserting the battery pack into a tool with the switch on invites accidents.
- **Remove adjusting keys or wrenches before turning the tool on.** A wrench or a key that is left attached to a rotating part of the tool may result in personal injury.

- **Do not overreach. Keep proper footing and balance at all times.** Proper footing and balance enable better control of the tool in unexpected situations.
- **Use safety equipment. Always wear eye protection.** Dust mask, non-skid safety shoes, hard hat, or hearing protection must be used for appropriate conditions.
- **Do not wear loose clothing or jewelry. Contain long hair.** Loose clothes, jewelry, or long hair can be drawn into air vents.
- **Do not use on a ladder or unstable support.** Stable footing on a solid surface enables better control of the tool in unexpected situations.

TOOL USE AND CARE

- **Use clamps or other practical way to secure and support the workpiece to a stable platform.** Holding the work by hand or against your body is unstable and may lead to loss of control.
- **Do not force tool. Use the correct tool for your application.** The correct tool will do the job better and safer at the rate for which it is designed.
- **Do not use tool if switch does not turn it on or off.** A tool that cannot be controlled with the switch is dangerous and must be repaired.
- **Disconnect battery pack from tool or place the switch in the locked or off position before making any adjustments, changing accessories, or storing the tool.** Such preventive safety measures reduce the risk of starting the tool accidentally.
- **Store idle tools out of reach of children and other untrained persons.** Tools are dangerous in the hands of untrained users.
- **When battery pack is not in use, keep it away from other metal objects like: paper clips, coins, keys, nails, screws, or other small metal objects that can make a connection from one terminal to another.** Shorting the battery terminals together may cause sparks, burns, or a fire.
- **Maintain tools with care. Keep cutting tools sharp and clean.** Properly maintained tools with sharp cutting edges are less likely to bind and are easier to control.
- **Check for misalignment or binding of moving parts, breakage of parts, and any other condition that may affect the tool's operation. If damaged, have the tool serviced before using.** Many accidents are caused by poorly maintained tools.
- **Use only accessories that are recommended by the manufacturer for your model.** Accessories that may be suitable for one tool may create a risk of injury when used on another tool.
- **Keep the tool and its handle dry, clean and free from oil and grease.** Always use a clean cloth when cleaning. Never use brake fluids, gasoline, petroleum-based products, or any strong solvents to clean your tool. Following this rule will reduce the risk of loss of control and deterioration of the enclosure plastic.

GENERAL SAFETY RULES

SERVICE

- **Tool service must be performed only by qualified repair personnel.** Service or maintenance performed by unqualified personnel may result in a risk of injury.
- **When servicing a tool, use only identical replacement parts. Follow instructions in the Maintenance section of this manual.** Use of unauthorized parts or failure to follow Maintenance Instructions may create a risk of shock or injury.

SPECIFIC SAFETY RULES

- **Hold tool by insulated gripping surfaces when performing an operation where the cutting tool may contact hidden wiring.** Contact with a “live” wire will also make exposed metal parts of the tool “live” and shock the operator.
- **Know your power tool. Read operator’s manual carefully. Learn its applications and limitations, as well as the specific potential hazards related to this tool.** Following this rule will reduce the risk of electric shock, fire, or serious injury.
- **Always wear safety glasses with side shields.** Everyday glasses have only impact resistant lenses. They are NOT safety glasses. Following this rule will reduce the risk of eye injury.
- **Protect your lungs. Wear a face or dust mask if the operation is dusty.** Following this rule will reduce the risk of serious personal injury.
- **Protect your hearing. Wear hearing protection during extended periods of operation.** Following this rule will reduce the risk of serious personal injury.
- **Battery tools do not have to be plugged into an electrical outlet; therefore, they are always in operating condition. Be aware of possible hazards when not using your battery tool or when changing accessories.** Following this rule will reduce the risk of electric shock, fire, or serious personal injury.
- **Do not place battery tools or their batteries near fire or heat.** This will reduce the risk of explosion and possibly injury.
- **Never use a battery that has been dropped or received a sharp blow.** A damaged battery is subject to explosion. Properly dispose of a dropped or damaged battery immediately.
- **Batteries vent hydrogen gas and can explode in the presence of a source of ignition, such as a pilot light.** To reduce the risk of serious personal injury, never use any cordless product in the presence of open flame. An exploded battery can propel debris and chemicals. If exposed, flush with water immediately.
- **Do not charge battery tool in a damp or wet location.** Following this rule will reduce the risk of electric shock.
- **For best results, your battery tool should be charged in a location where the temperature is more than 50°F but less than 100°F. Do not store outside or in vehicles.**
- **Under extreme usage or temperature conditions, battery leakage may occur. If liquid comes in contact with your skin, wash immediately with soap and water, then neutralize with lemon juice or vinegar. If liquid gets into your eyes, flush them with clean water for at least 10 minutes, then seek immediate medical attention.** Following this rule will reduce the risk of serious personal injury.

SAFETY RULES FOR CHARGER

⚠ WARNING! READ AND UNDERSTAND ALL INSTRUCTIONS. Failure to follow all instructions listed below, may result in electric shock, fire and/or serious personal injury.

■ **Before using battery charger**, read all instructions and cautionary markings in this manual, on battery charger, battery, and product using battery to prevent misuse of the products and possible injury or damage.

⚠ CAUTION: To reduce the risk of electric shock or damage to the charger and battery, charge only nickel-cadmium rechargeable batteries as specifically designated on your charger. Other types of batteries may burst, causing personal injury or damage.

■ **Do not use charger outdoors or expose to wet or damp conditions.** Water entering charger will increase the risk of electric shock.

■ **Use of an attachment not recommended or sold by the battery charger manufacturer may result in a risk of fire, electric shock, or injury to persons.** Following this rule will reduce the risk of electric shock, fire, or serious personal injury.

■ **Do not abuse cord or charger.** Never use the cord to carry the charger. Do not pull the charger cord rather than the plug when disconnecting from receptacle. Damage to the cord or charger could occur and create an electric shock hazard. Replace damaged cords immediately.

■ **Make sure cord is located so that it will not be stepped on, tripped over, come in contact with sharp edges or moving parts or otherwise subjected to damage or stress.** This will reduce the risk of accidental falls, which could cause injury, and damage to the cord, which could result in electric shock.

■ **Keep cord and charger from heat to prevent damage to housing or internal parts.**

■ **Do not let gasoline, oils, petroleum-based products, etc. come in contact with plastic parts.** They contain chemicals that can damage, weaken, or destroy plastic.

■ **An extension cord should not be used unless absolutely necessary.** Use of improper extension cord could result in a risk of fire and electric shock. If extension cord must be used, make sure:

- That pins on plug of extension cord are the same number, size and shape as those of plug on charger.
- That extension cord is properly wired and in good electrical condition; and
- That wire size is large enough for AC ampere rating of charger as specified below:

Cord Length (Feet)	25'	50'	100'
Cord Size (AWG)	16	16	16

NOTE: AWG = American Wire Gauge

- **Do not operate charger with a damaged cord or plug**, which could cause shorting and electric shock. If damaged, have the charger replaced by an authorized serviceman.
- **Do not operate charger if it has received a sharp blow, been dropped, or otherwise damaged in any way.** Take it to an authorized serviceman for electrical check to determine if the charger is in good working order.
- **Do not disassemble charger.** Take it to an authorized serviceman when service or repair is required. Incorrect reassembly may result in a risk of electric shock or fire.
- **Unplug charger from outlet before attempting any maintenance or cleaning to reduce the risk of electric shock.**
- **Disconnect charger from the power supply when not in use.** This will reduce the risk of electric shock or damage to the charger if metal items should fall into the opening. It also will help prevent damage to the charger during a power surge.
- **Risk of electric shock.** Do not touch uninsulated portion of output connector or uninsulated battery terminal.
- **Save these instructions.** Refer to them frequently and use them to instruct others who may use this tool. If you loan someone this tool, loan them these instructions also to prevent misuse of the product and possible injury.











⚠ WARNING: Some dust created by power sanding, sawing, grinding, drilling, and other construction activities contains chemicals known to cause cancer, birth defects or other reproductive harm. Some examples of these chemicals are:

- lead from lead-based paints,
- crystalline silica from bricks and cement and other masonry products, and
- arsenic and chromium from chemically-treated lumber.

Your risk from these exposures varies, depending on how often you do this type of work. To reduce your exposure to these chemicals: work in a well ventilated area, and work with approved safety equipment, such as those dust masks that are specially designed to filter out microscopic particles.



SYMBOLS

Some of the following symbols may be used on this tool. Please study them and learn their meaning. Proper interpretation of these symbols will allow you to operate the tool better and safer.

SYMBOL	NAME	DESIGNATION/EXPLANATION
V	Volts	Voltage
A	Amperes	Current
Hz	Hertz	Frequency (cycles per second)
W	Watt	Power
min	Minutes	Time
~	Alternating Current	Type of current
==	Direct Current	Type or a characteristic of current
n_0	No Load Speed	Rotational speed, at no load
	Class II Construction	Double-insulated construction
.../min	Per Minute	Revolutions, strokes, surface speed, orbits etc., per minute
	Wet Conditions Alert	Do not expose to rain or use in damp locations.
	Read The Operator's Manual	To reduce the risk of injury, user must read and understand operator's manual before using this product.
	Eye Protection	Always wear safety goggles or safety glasses with side shields and a full face shield when operating this product.
	Safety Alert	Precautions that involve your safety.
	No Hands Symbol	Failure to keep your hands away from the blade will result in serious personal injury.
	No Hands Symbol	Failure to keep your hands away from the blade will result in serious personal injury.
	No Hands Symbol	Failure to keep your hands away from the blade will result in serious personal injury.
	No Hands Symbol	Failure to keep your hands away from the blade will result in serious personal injury.
	Hot Surface	To reduce the risk of injury or damage, avoid contact with any hot surface.

SYMBOLS

The following signal words and meanings are intended to explain the levels of risk associated with this product.

SYMBOL	SIGNAL	MEANING
	DANGER:	Indicates an imminently hazardous situation, which, if not avoided, will result in death or serious injury.
	WARNING:	Indicates a potentially hazardous situation, which, if not avoided, could result in death or serious injury.
	CAUTION:	Indicates a potentially hazardous situation, which, if not avoided, may result in minor or moderate injury.
	CAUTION:	(Without Safety Alert Symbol) Indicates a situation that may result in property damage.

SERVICE

Servicing requires extreme care and knowledge and should be performed only by a qualified service technician. For service we suggest you return the product to your nearest **AUTHORIZED SERVICE CENTER** for repair. When servicing, use only identical replacement parts.

 **WARNING:** To avoid serious personal injury, do not attempt to use this product until you read thoroughly and understand completely the operator's manual. Save this operator's manual and review frequently for continuing safe operation and instructing others who may use this product.

WARNING:



The operation of any power tool can result in foreign objects being thrown into your eyes, which can result in severe eye damage. Before beginning power tool operation, always wear safety goggles or safety glasses with side shields and a full face shield when needed. We recommend Wide Vision Safety Mask for use over eyeglasses or standard safety glasses with side shields. Always use eye protection which is marked to comply with ANSI Z87.1.

SAVE THESE INSTRUCTIONS

FEATURES

PRODUCT SPECIFICATIONS

Length of Stroke.....	1 in.
Strokes Per Minute.....	0-2,100 /min
Switch.....	Variable Speed
Blade Clamp.....	Tool-less
Cutting Angle.....	0° to 45° both Left and Right
Orbital Motion.....	4 Positions

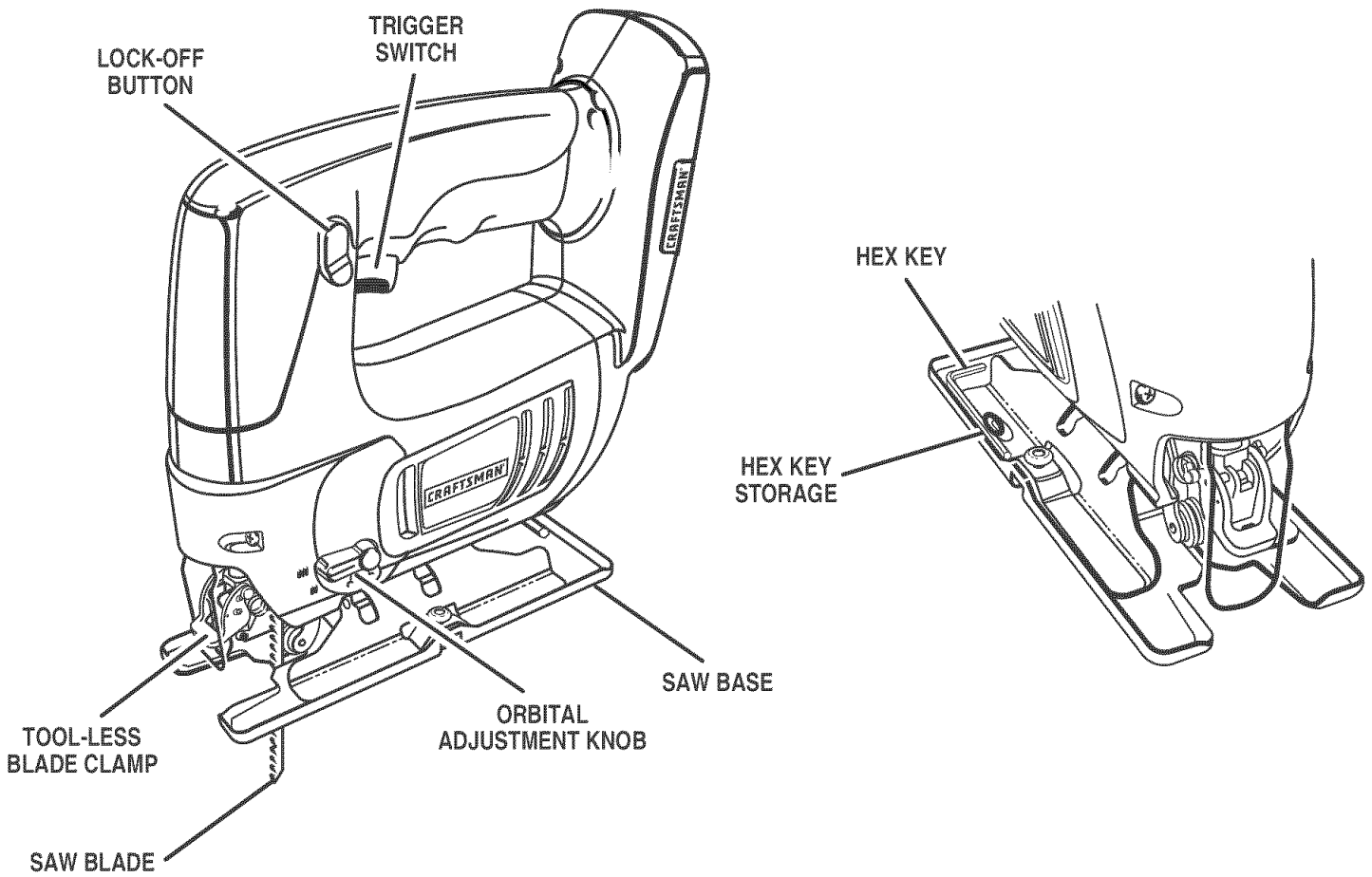

Fig. 1

FEATURES

KNOW THIS TOOL

See Figure 1.

Before attempting to use this tool, familiarize yourself with all operating features and safety requirements.

TOOL-LESS BLADE CLAMP

Your saw has a blade clamp design that does not require the use of a tool (blade wrench) when installing or removing the blade. Simply lift blade clamp lock / release lever, located on front of saw, insert blade between blade clamp and saw bar as far as possible, then release lever to lock position.

BLADE SELECTION

To obtain the best performance from your saw it is important to select a specific blade for the particular application and type of material you wish to cut. By doing this you will get a smoother, faster cut and prolong blade life. Replacement blades for this saw are available from your nearest Sears dealer. Sears recommends the use of a T-shank blade. If a T-shank blade is not available, a high quality U-shank may be used.

LOCK-OFF BUTTON

Your saw is equipped with a "lock-off" button which reduces the possibility of accidental starting. The lock-off button is located on the handle above the switch trigger. You must depress the lock-off button in order to pull the switch trigger. The lock resets each time the trigger is released.

NOTE: You can depress the lock-off button from either the left or right side.

SWITCH

To turn your saw **ON**, depress the lock-off button and pull switch trigger. Release switch trigger to turn your saw **OFF**.

VARIABLE SPEED

This tool has a variable speed switch that delivers higher speed with increased trigger pressure. Speed is controlled by the amount of switch trigger depression.

BLADE STORAGE

When not in use, you can place the blades provided with your orbital jig saw in the storage area located on the back of the saw.

ORBITAL ADJUSTMENT KNOB

Four position orbital adjustment for fine to aggressive cutting.

ERGONOMIC DESIGN

The design of the orbital jig saw provides for easy handling. It is designed for comfort and ease of grasp when operating in different positions and at different angles.

ASSEMBLY

UNPACKING

Your jig saw has been shipped completely assembled.

- Make sure that all items listed in the packing list are included.
- Inspect the tool carefully to make sure no breakage or damage occurred during shipping.
- Do not discard the packing material until you have carefully inspected and satisfactorily operated the tool.
- If any parts are damaged or missing, please call 1-800-932-3188.

PACKING LIST

Orbital Jig Saw
Blades (2)
Operator's Manual

 **WARNING:** If any parts are missing do not operate this tool until the missing parts are replaced. Failure to do so could result in possible serious personal injury.

 **WARNING:** Do not attempt to modify this tool or create accessories not recommended for use with this tool. Any such alteration or modification is misuse and could result in a hazardous condition leading to possible serious personal injury.

 **WARNING:** To prevent accidental starting that could cause serious personal injury, always remove the battery pack from the tool when assembling parts.

OPERATION

WARNING: Do not allow familiarity with tools to make you careless. Remember that a careless fraction of a second is sufficient to inflict serious injury.

WARNING: Always wear safety goggles or safety glasses with side shields when operating tools. Failure to do so could result in objects being thrown into your eyes, resulting in possible serious injury.

APPLICATIONS

You may use this tool for the following purposes:

- Sawing non-ferrous metal, sheet steel, wood, plastic, and similar materials.
- Cutting wood surfaces.
- Cutting thin sheet metal.
- Cutting plastics and laminates.

CAUTION: To prevent damage to the battery pack, remove the battery pack from the charger immediately if no LED comes on. Return the battery pack and charger to your nearest service center for checking or replacing. Also, if you are removing the battery pack from the charger and no LEDs are on, return both the battery pack and the charger to your nearest service center. Do not insert another battery pack into the charger. A damaged charger may damage a battery pack.

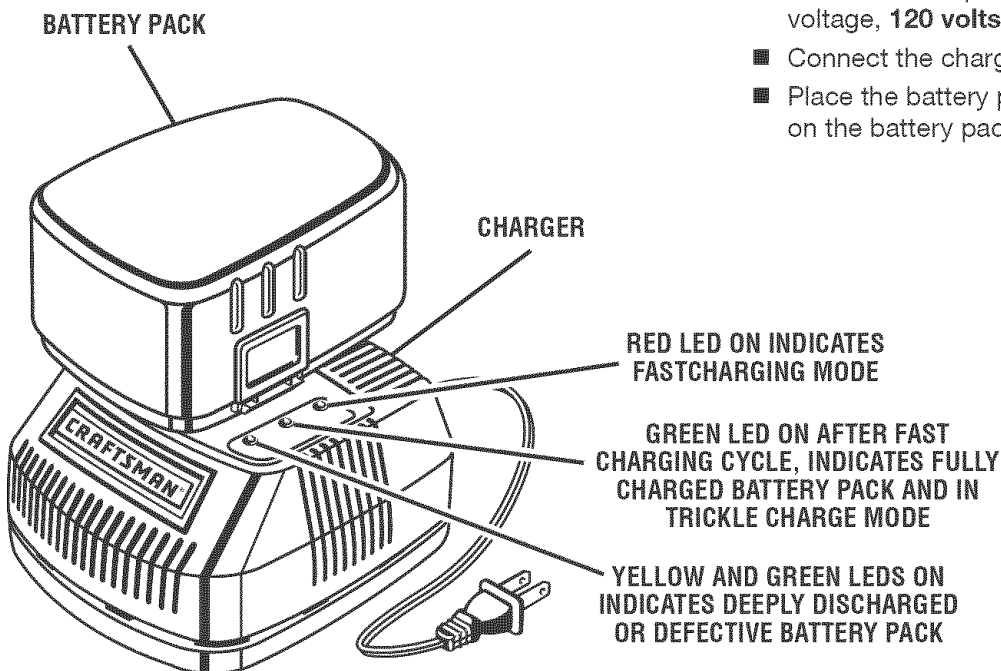

LED FUNCTIONS OF CHARGER

LED WILL BE ON TO INDICATE STATUS OF CHARGER AND BATTERY PACK:

- Red LED on = Fast charging mode.
- Green LED on = Fully charged and in trickle charge mode.
- Green LED on = When battery pack is inserted into charger, indicates hot battery pack or that battery pack is out of or below normal temperature range.
- Yellow and Green LEDs on = Deeply discharged or defective battery pack.
- No LED on = Defective charger or battery pack.

CHARGING THE BATTERY PACK

Battery packs for this tool have been shipped in a low charge condition to prevent possible problems. Therefore, you should charge it until the green LED on the front of the charger comes on.

NOTE: Batteries will not reach full charge the first time they are charged. Allow several cycles (operation followed by recharging) for them to become fully charged.

CHARGING A COOL BATTERY PACK

See Figure 2.

If battery pack is below normal temperature range, the green LED on charger will come on. Allow battery pack to reach normal temperature, then the red LED will come on.

NOTE: If the charger does not charge the battery pack under normal circumstances, return both the battery pack and charger to your nearest Sears Repair Center for electrical check.

- Charge the battery pack only with the charger provided.
- Make sure the power supply is normal household voltage, **120 volts, 60 Hz, AC only**.
- Connect the charger to the power supply.
- Place the battery pack in the charger aligning raised rib on the battery pack with the groove in the charger.

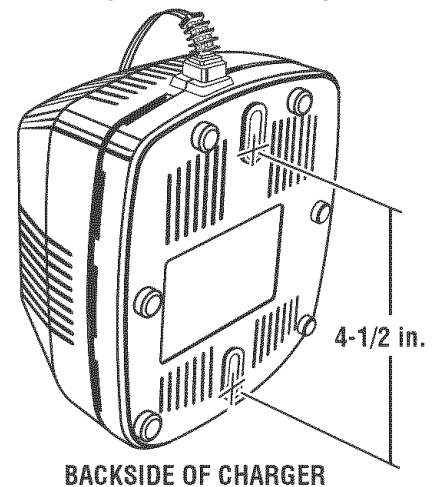

Fig. 2

OPERATION

- Press down on the battery pack to be sure contacts on the battery pack engage properly with contacts in the charger.
 - Normally the red LED on charger will come on. This indicates the charger is in fast charging mode.
 - Red LED should remain on for approximately 1 hour then the green LED will come on. Green LED on indicates battery pack is fully charged and charger is in maintenance charge mode.
- NOTE:** The green LED will remain on until the battery pack is removed from the charger or charger is disconnected from the power supply.
- If both yellow and green LEDs come on, this indicates a deeply discharged or defective battery pack. Allow the battery pack to remain in the charger for 15 to 30 minutes. When the battery pack reaches normal voltage range, the red LED should come on. If the red LED does not come on after 30 minutes, this may indicate a defective battery pack and should be replaced.
 - After normal usage, a minimum of 1 hour of charging time is required to fully recharge battery pack.
 - The battery pack will become slightly warm to the touch while charging. This is normal and does not indicate a problem.
 - Do not place the charger and battery pack in an area of extreme heat or cold. They will work best at normal room temperature.

NOTE: The charger and battery pack should be placed in a location where the temperature is more than 50°F but less than 100°F.

- When batteries become fully charged, unplug the charger from power supply and remove the battery pack.

CHARGING A HOT BATTERY PACK

When using the tool continuously, the batteries in the battery pack will become hot. You should let a hot battery pack cool down for approximately 30 minutes before attempting to recharge. When the battery pack becomes discharged and is hot, this will cause the green LED to come on instead of the red LED. After 30 minutes, reinsert the battery pack in the charger. If the green LED continues to remain on, return battery pack to your nearest Sears Repair Center for checking or replacing.

NOTE: This situation only occurs when continuous use of the tool causes the batteries to become hot. It does not occur under normal circumstances. Refer to “**CHARGING A COOL BATTERY PACK**” for normal recharging of batteries. If the charger does not charge your battery pack under normal circumstances, return both the battery pack and charger to your nearest Sears Repair Center for electrical check.

TO INSTALL BATTERY PACK

See Figure 3.

Follow these steps to install the battery pack.

- Lock the trigger switch by placing the rotation selector in the center position.
- Place the battery pack on the tool.
- Make sure the latches on each side of the battery pack snap into place and the battery pack is secured on the tool before beginning operation.

CAUTION: When placing the battery pack in the tool, be sure raised rib on battery pack aligns with the groove in the tool and that the latches snap into place properly. Improper assembly of the battery pack can cause damage to internal components.

TO REMOVE BATTERY PACK

See Figure 3.

Follow these steps to remove the battery pack.

- Lock the trigger switch by placing the rotation selector in the center position.
- Depress the latches on the side of battery pack.
- Remove the battery pack from the tool.

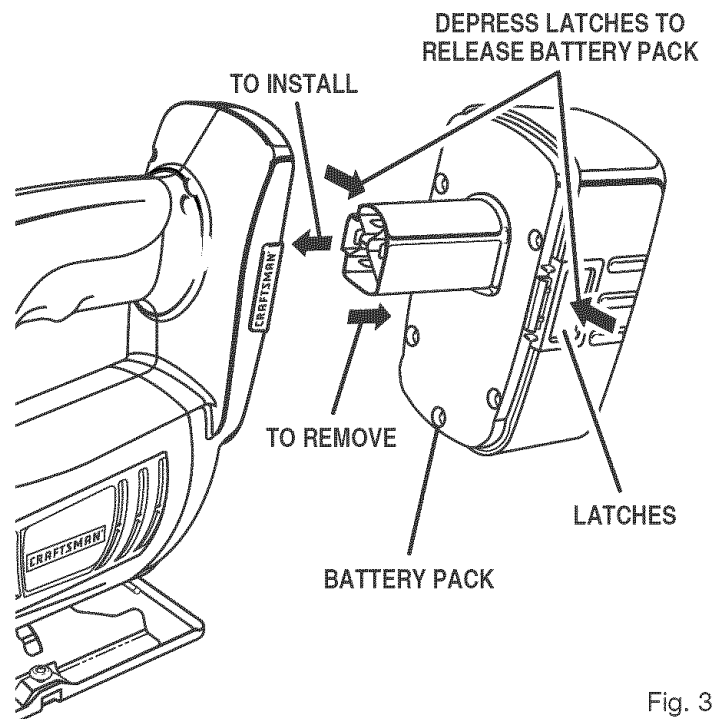

Fig. 3

OPERATION

⚠ WARNING: Battery tools are always in operating condition. Therefore, switch should always be locked when not in use or carrying at your side.

TO INSTALL BLADES

See Figure 4.

- Remove battery pack. See Figure 3.
- Lift blade clamp lock / release lever located on front of saw.
- Insert saw blade between blade clamp and saw bar.
- Release and lock blade clamp lever.
- Replace battery pack.

HEX KEY STORAGE

See Figure 5.

- Secure supplied hex key on the saw base behind the rubber covered tab. Push into place.
- Make sure the hex key is secured before performing any sawing operation.
- Remove by pulling on the hex key.

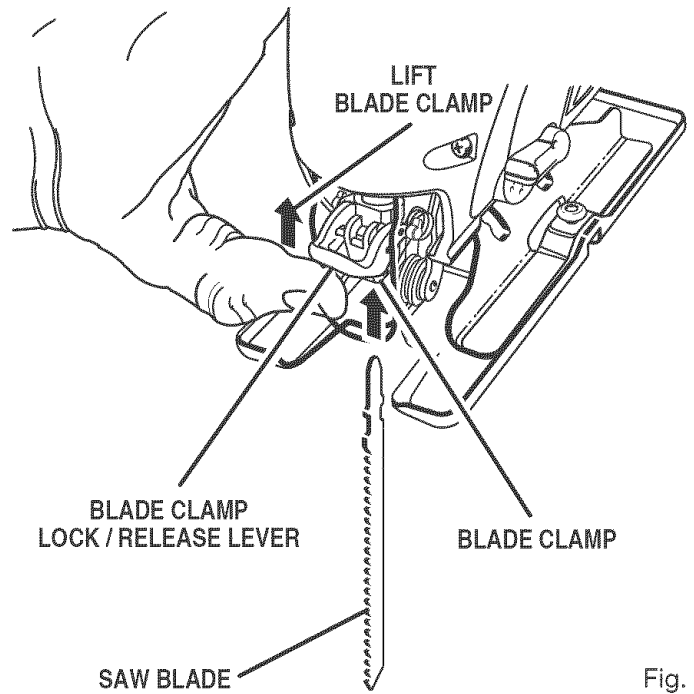

Fig. 4

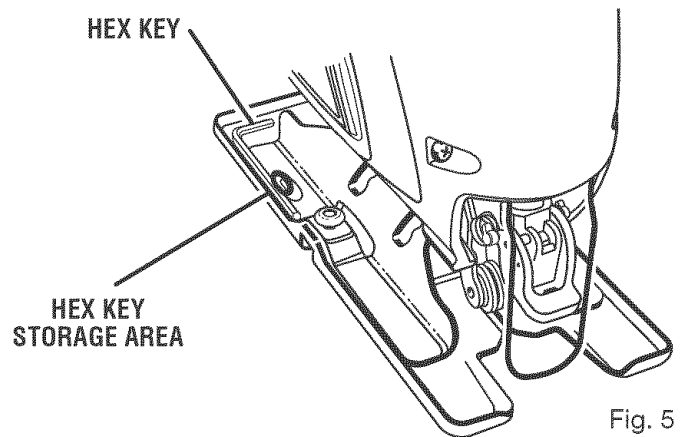

Fig. 5

OPERATION

GENERAL CUTTING

See Figure 6.

Rest the front of the saw base on the workpiece and align cutting edge of the blade with the line on your workpiece. Start your saw and move it forward on the work surface. Apply downward pressure to keep the saw steady and only enough forward pressure to keep the blade cutting.

DO NOT FORCE YOUR SAW

Forcing your saw may overheat the motor and break saw blades. Broken saw blades must be discarded. Remove the broken portion of the saw blade from the clamp and install a new saw blade.

ORBITAL MOTION

See Figure 6.

The blade of your saw cuts in orbital motion. This feature is adjustable and provides faster more efficient cutting. The blade cuts through your work in the upstroke but does not drag across your work in the downstroke. The higher settings should be used when fast cutting in soft material is desired. The lower settings should be used when cutting materials with more resistance.

STRAIGHT CUT

See Figure 6.

A straight cut can be made by clamping a piece of wood or straightedge to the workpiece and guiding the edge of your saw against it. Make the cut from one direction only. Don't cut halfway and complete the cut from the opposite end.

SCROLL CUTTING

See Figure 7.

Scroll cuts can be made with your jig saw by guiding the direction of the cut with applied pressure on the handle as shown in figure 7.

⚠ WARNING: Excessive side pressure to the blade could result in broken blades or damage to the material being cut.

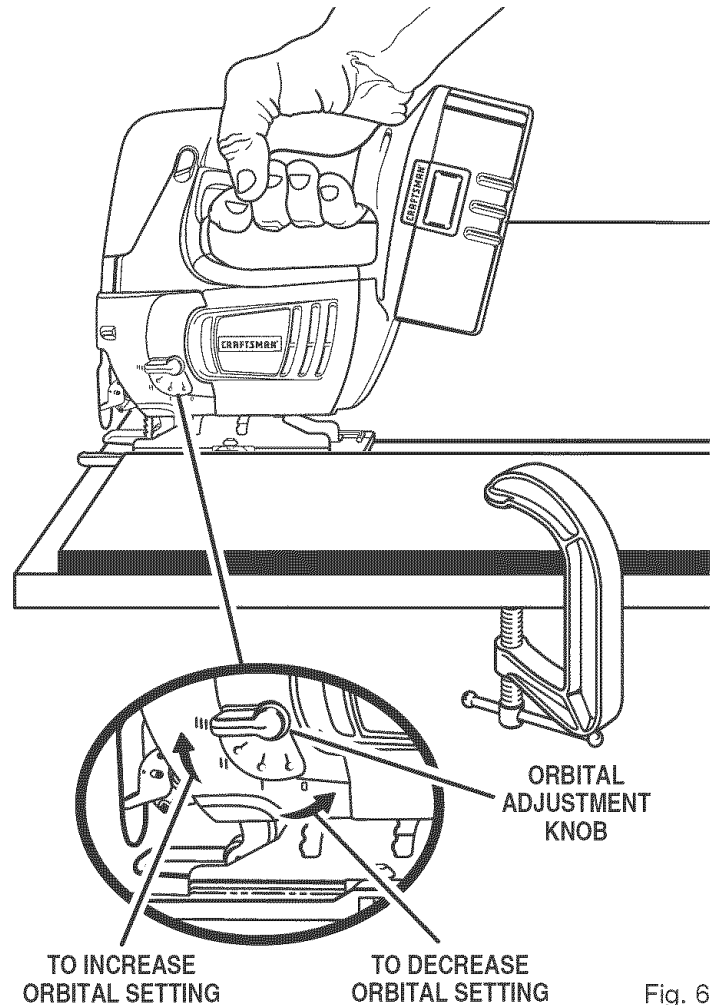

Fig. 6

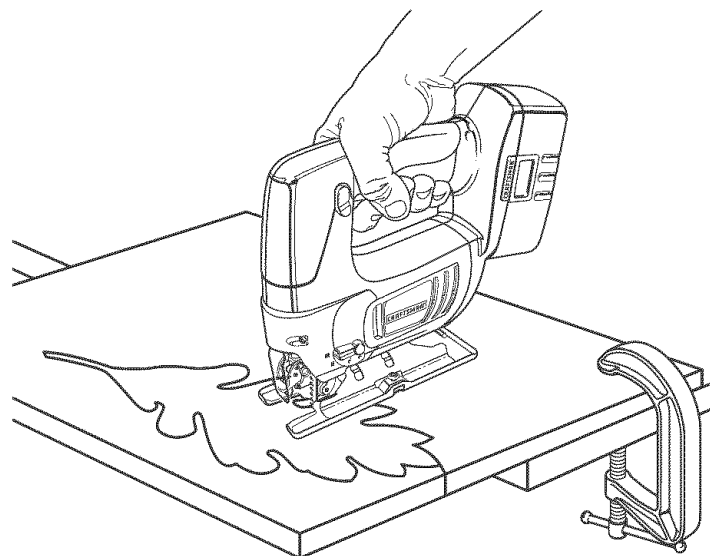

Fig. 7

OPERATION

ANGLE CUTTING (BEVEL CUTTING)

See Figures 8 - 9.

Bevel cutting angles may be adjusted from 0° to 45° right or left. Angles for cuts from 0° to 45° in 15° increments are marked on a scale on both the left and right side of the base. Notches on the rear of the base provide positive stops at each of the above mentioned 15° increments. A protractor is recommended when accurate cuts are required.

- Using the 1/8 in. hex key provided, loosen the base pivot screws until the base can be moved.
- Slide base forward until base pivot screws can move freely in slots in base.
- Align the mark, on the base, of the desired angle with the edge of the motor housing.
- Once the desired angle is reached, slide base back until tab on motor housing aligns with the appropriate notch on rear of base.

NOTE: When making a set-up for accurate cuts with a protractor, or for angles other than the preset 15° increments, the positive stop notches on the rear of the base are not used.

- Tighten the base pivot screws securely.
- Return hex key to storage compartment.

NOTE: The wide slot in the base must be used when making bevel cuts, scroll cuts, plunge cuts, and when cutting metal.

PLUNGE CUTTING

See Figures 10 - 11.

⚠ WARNING: To avoid loss of control, broken blades, or damage to the material being cut, always use extreme caution when making plunge cuts. We do not recommend plunge cutting on materials other than wood.

TO MAKE A PLUNGE CUT:

- Mark the line of cut clearly on the workpiece.
- Set the cutting angle at 0°.
- Set the orbital adjustment knob to 0.
- Tilt your saw forward so that it rests on the front edge of the base and blade will not come in contact with the workpiece when the saw is turned on.
- Make sure the blade is inside the area to be cut.
- Using high speed, start your saw and slowly lower the blade into the workpiece until the blade cuts through the wood.
- Do not move the base forward until the blade cuts entirely through the workpiece and the base is in complete contact with the workpiece.
- Move the saw forward to complete the opening.
- Use only the 7 teeth per inch blade for this type of cut.

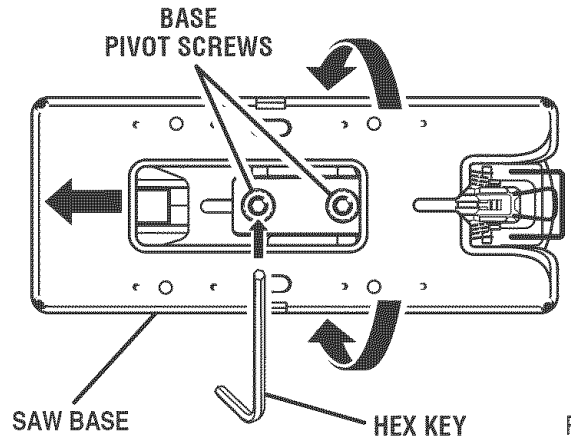

Fig. 8

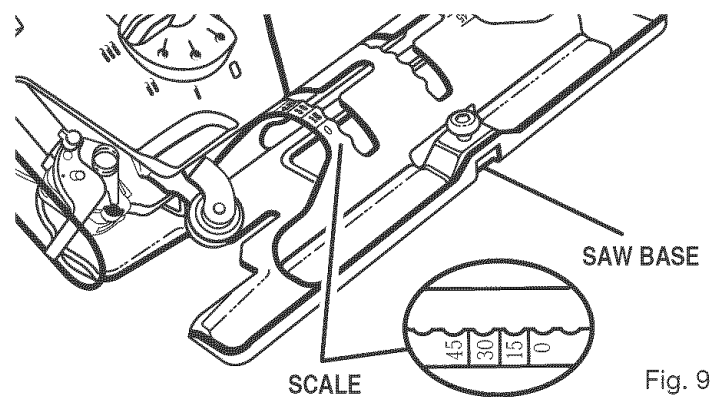

Fig. 9

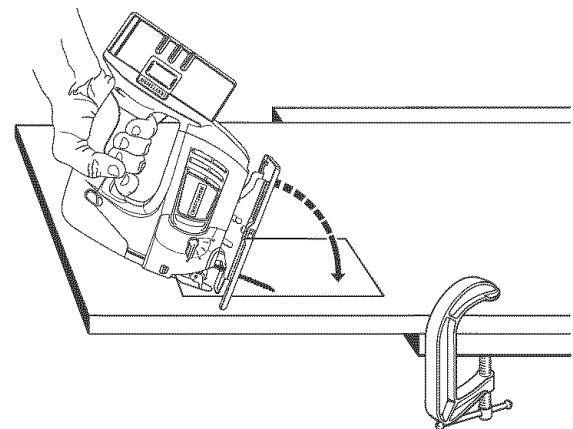

Fig. 10

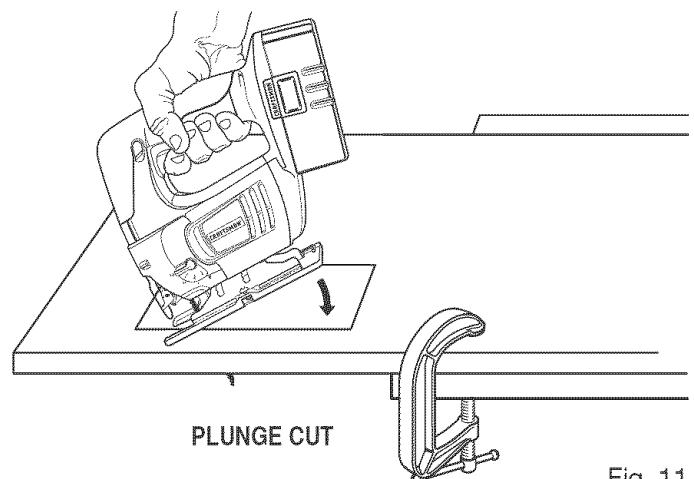

Fig. 11

OPERATION

SPLINTER-FREE CUTTING

See Figures 12 - 13.

The base of your jig saw has a narrow slot to permit splinter-free cutting. It is especially useful when cutting plywood. This feature should only be used when making straight cuts or circle cuts. It is not for bevel cutting or plunge cutting.

NOTE: The non-orbital setting also helps reduce splintering when cutting plywood.

HOW TO POSITION BASE IN THE SPLINTER-FREE CUTTING POSITION:

- Remove battery pack.
- Using the 1/8 in. hex key provided, loosen base pivot screws and slide base forward.
- Always set the cutting angle at 0° for splinter-free cutting. To set cutting angle at 0°, align the 0° mark on the scale with the edge of the motor housing.

NOTE: When setting angle at 0° for splinter-free cutting, the positive stop notches on the rear of the base are not used.

- Tighten base pivot screws securely.
- Remove hex key and return it to storage compartment.
- Replace battery pack.

OPTIONAL EDGE GUIDE

See Figure 14.

An optional edge guide is available for use with your saw. It can be used for making crosscuts and rip cuts.

- Remove battery pack.
- Loosen edge guide screw.
- Insert the arm through the two slots in the base of your saw as shown.
- Adjust edge guide to the desired width and lock in place with the edge guide screw.
- Replace battery pack.

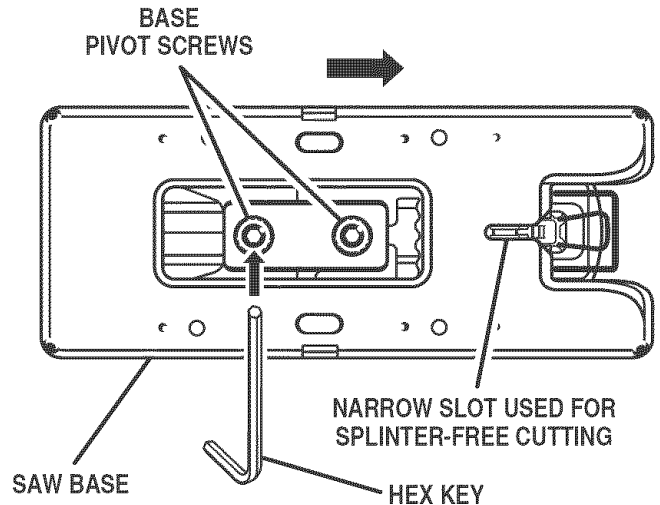

Fig. 12

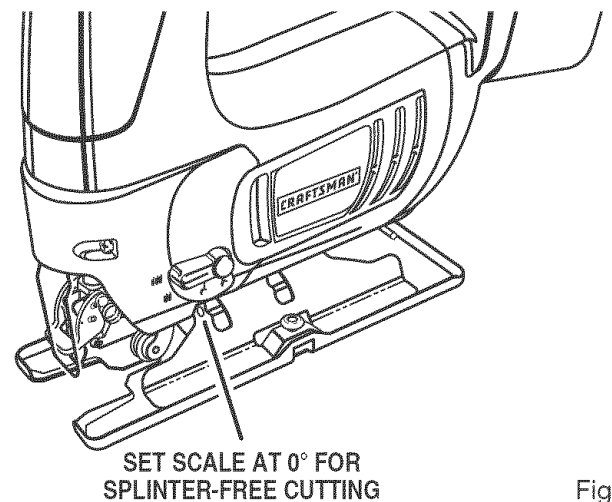

Fig. 13

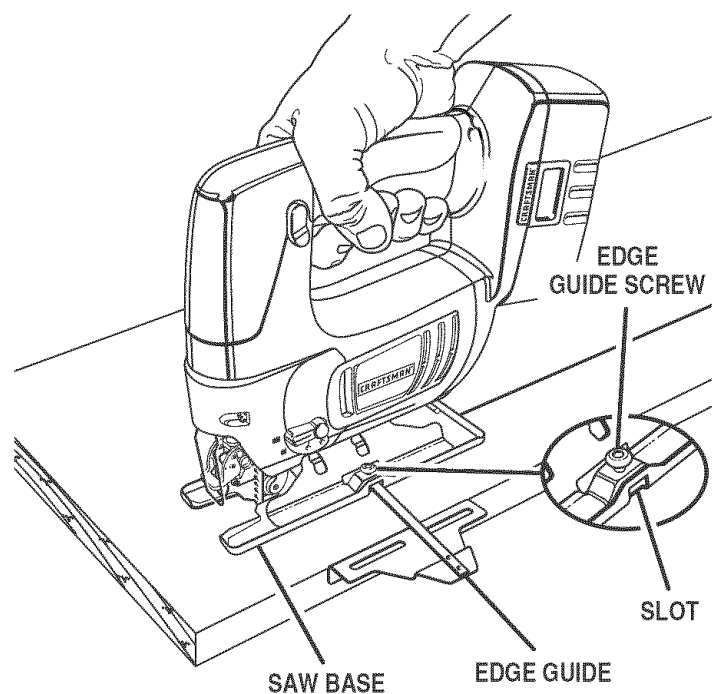

Fig. 14

MAINTENANCE

WARNING: When servicing, use only identical Craftsman replacement parts. Use of any other part may create a hazard or cause product damage.

WARNING: Always wear safety goggles or safety glasses with side shields when using compressed air to clean tools. If the operation is dusty, also wear a dust mask.

WARNING: To avoid serious personal injury, always remove the battery pack from the tool when cleaning or performing any maintenance.

WARNING: Do not at any time let brake fluids, gasoline, petroleum-based products, penetrating oils, etc. come in contact with plastic parts. Chemicals can damage, weaken or destroy plastic which may result in serious personal injury.

Only the parts shown on the parts list are intended to be repaired or replaced by the customer. All other parts should be replaced at a Sears Service Center.

GENERAL MAINTENANCE

Avoid using solvents when cleaning plastic parts. Most plastics are susceptible to damage from various types of commercial solvents and may be damaged by their use. Use clean cloths to remove dirt, dust, oil, grease, etc.

BATTERIES

The battery pack for this tool is equipped with nickel-cadmium rechargeable batteries. Length of service from each charging will depend on the type of work you are doing.

The batteries in this tool have been designed to provide maximum trouble-free life. However, like all batteries, they will eventually wear out. **Do not** disassemble battery pack and attempt to replace the batteries. Handling of these batteries, especially when wearing rings and jewelry, could result in a serious burn.

To obtain the longest possible battery life, we suggest the following:

- Remove the battery pack from the charger once it is fully charged and ready for use.

For battery pack storage longer than 30 days:

- Store the battery pack where the temperature is below 80°F.
- Store battery packs in a "discharged" condition.

BATTERY PACK REMOVAL AND PREPARATION FOR RECYCLING



To preserve natural resources, please recycle or dispose of batteries properly.

This product contains nickel-cadmium batteries. Local, state or federal laws may prohibit disposal of nickel-cadmium batteries in ordinary trash.

Consult your local waste authority for information regarding available recycling and/or disposal options.

WARNING: Upon removal, cover the battery pack's terminals with heavy-duty adhesive tape. Do not attempt to destroy or disassemble battery pack or remove any of its components. Nickel-cadmium batteries must be recycled or disposed of properly. Also, never touch both terminals with metal objects and/or body parts as short circuit may result. Keep away from children. Failure to comply with these warnings could result in fire and/or serious injury.

ACCESSORIES

The following recommended accessories are currently available at Sears retail stores:

- Edge Guide..... Item No. 9 27959

WARNING: Current attachments and accessories available for use with this tool are listed above. Do not use any attachments or accessories not recommended by the manufacturer of this tool. The use of attachments or accessories not recommended can result in serious personal injury.

CRAFTSMAN 19.2 VOLT CORDLESS JIG SAW – MODEL NO. 315.114280

The model number will be found on a plate attached to the motor housing. Always mention the model number in all correspondence regarding your **CORDLESS JIG SAW** or when ordering repair parts.

SEE BACK PAGE FOR PARTS ORDERING INSTRUCTIONS

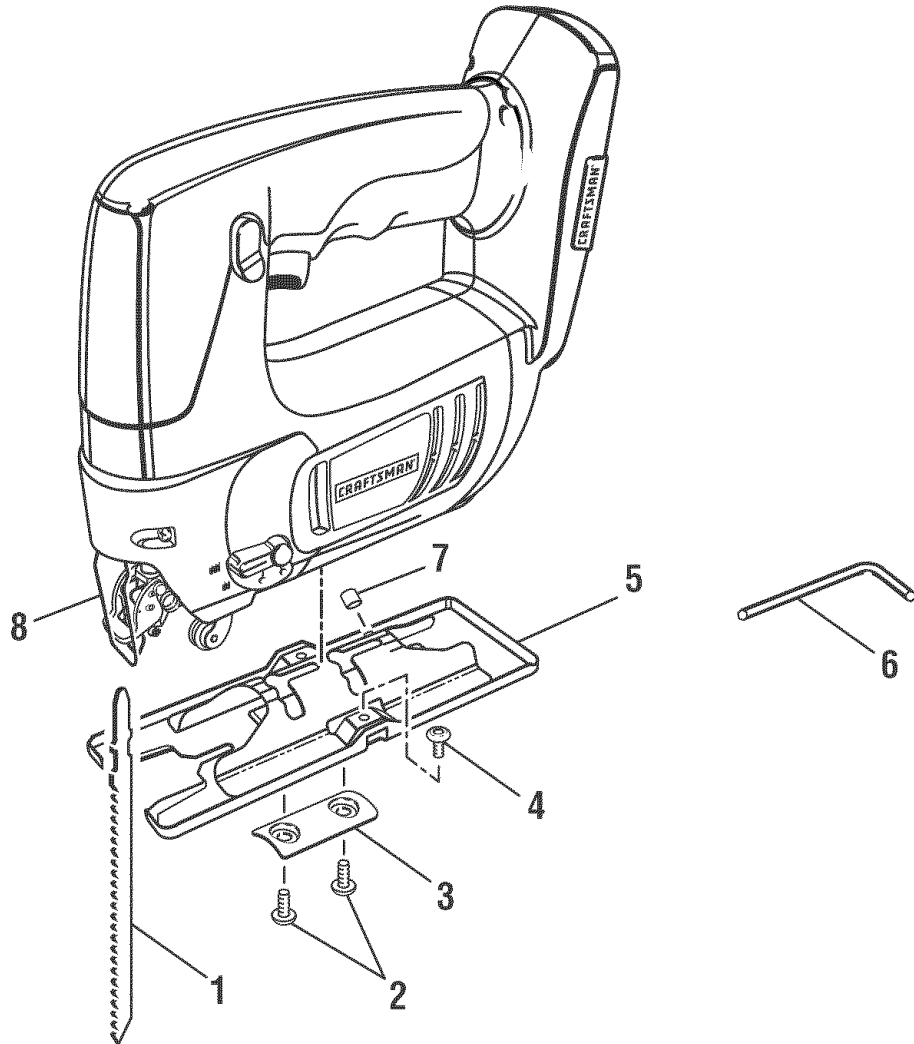

PARTS LIST

Key No.	Part Number	Description	Qty.	Key No.	Part Number	Description	Qty.
1	690227036	Metal Cutting Blade.....	1	6	680907001	Hex Key	1
1	690227035	Wood Cutting Blade	1	7	550432001	Rubber Tube	1
2	660302002	Screw	2	8	671314002	Blade Guard	1
3	630847003	Plate	1		130139020	Battery Pack (9 11375).....	0
4	660302001	Screw	1		1425301	Charger (9 11041).....	0
5	630846007	Base	1		983000-488	Operator's Manual	

* Can Be Purchased Thru RSOS (Retail Special Order System)

Free Manuals Download Website

<http://myh66.com>

<http://usermanuals.us>

<http://www.somanuals.com>

<http://www.4manuals.cc>

<http://www.manual-lib.com>

<http://www.404manual.com>

<http://www.luxmanual.com>

<http://aubethermostatmanual.com>

Golf course search by state

<http://golfingnear.com>

Email search by domain

<http://emailbydomain.com>

Auto manuals search

<http://auto.somanuals.com>

TV manuals search

<http://tv.somanuals.com>