

Operator's Manual

CRAFTSMAN®

1/2 in., 19.2 VOLT CORDLESS DRILL-DRIVER Variable Speed / Reversible

Model No.
315.114850

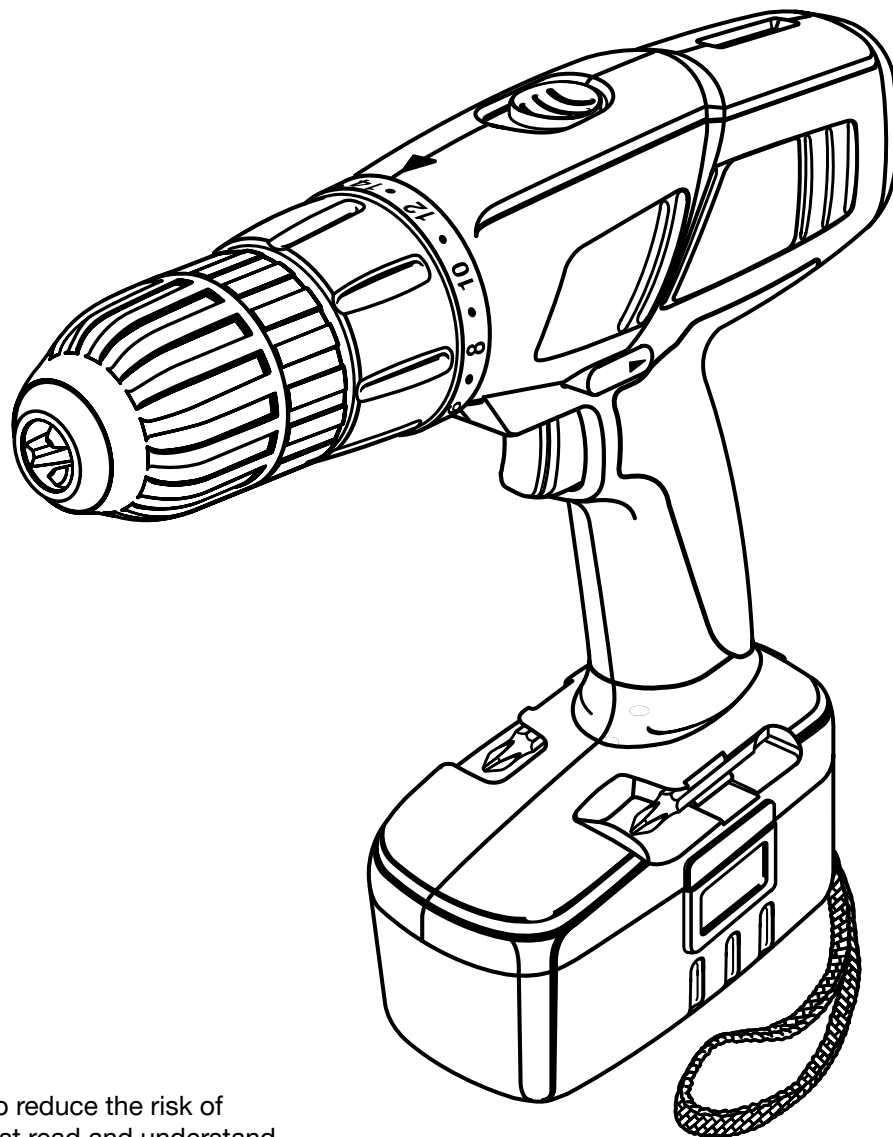

WARNING: To reduce the risk of injury, the user must read and understand the operator's manual before using this product.

Customer Help Line: 1-800-932-3188

Sears, Roebuck and Co., 3333 Beverly Rd., Hoffman Estates, IL 60179 USA
Visit the Craftsman web page: www.sears.com/craftsman



TABLE OF CONTENTS

■ Warranty	2
■ Introduction	2
■ General Safety Rules	3-4
■ Specific Safety Rules	4
■ Safety Instructions for Charger	5
■ Symbols.....	6-7
■ Features	8-9
■ Unpacking	10
■ Operation.....	11-16
■ Maintenance.....	17
■ Exploded View And Repair Parts List.....	19
■ Parts Ordering / Service	20

WARRANTY

FULL ONE YEAR WARRANTY ON CRAFTSMAN 1/2 in. CORDLESS DRILL-DRIVER

If this **CRAFTSMAN** 1/2 in. Cordless Drill-Driver fails to give complete satisfaction within one year from the date of purchase, **RETURN IT TO THE NEAREST SEARS STORE OR SEARS SERVICE CENTER IN THE UNITED STATES**, and Sears will repair it, free of charge.

If this **CRAFTSMAN** 1/2 in. Cordless Drill-Driver is used for commercial or rental purposes, this warranty applies for only 90 days from the date of purchase.

This warranty gives you specific legal rights, and you may also have other rights which vary from state to state.

Sears, Roebuck and Co., Dept. 817WA, Hoffman Estates, IL 60179

INTRODUCTION

This tool has many features for making its use more pleasant and enjoyable. Safety, performance, and dependability have been given top priority in the design of this product making it easy to maintain and operate.

GENERAL SAFETY RULES

⚠ WARNING: READ AND UNDERSTAND ALL INSTRUCTIONS. Failure to follow all instructions listed below, may result in electric shock, fire and/or serious personal injury.

SAVE THESE INSTRUCTIONS

WORK AREA

- **Keep your work area clean and well lit.** Cluttered benches and dark areas invite accidents.
- **Do not operate power tools in explosive atmospheres, such as in the presence of flammable liquids, gases, or dust.** Power tools create sparks which may ignite the dust or fumes.
- **Keep bystanders, children, and visitors away while operating a power tool.** Distractions can cause you to lose control.

ELECTRICAL SAFETY

- **A battery operated tool with integral batteries or a separate battery pack must be recharged only with the specified charger for the battery.** A charger that may be suitable for one type of battery may create a risk of fire when used with another battery. Use battery only with charger listed.

MODEL	BATTERY PACK	CHARGER
315.114850	ITEM NO. 9 11375 (1323517 or 1323903)	ITEM NO. 9 11041 (1425301)

- **Use battery operated tool only with specifically designated battery pack.** Use of any other batteries may create a risk of fire. Use only with battery pack listed.
- **Do not abuse the cord. Never use the cord to carry the charger. Keep cord away from heat, oil, sharp edges, or moving parts. Replace damaged cords immediately.** Damaged cords may create a fire.

PERSONAL SAFETY

- **Stay alert, watch what you are doing and use common sense when operating a power tool. Do not use tool while tired or under the influence of drugs, alcohol, or medication.** A moment of inattention while operating power tools may result in serious personal injury.
- **Dress properly. Do not wear loose clothing or jewelry. Contain long hair. Keep your hair, clothing, and gloves away from moving parts.** Loose clothes, jewelry, or long hair can be caught in moving parts.
- **Avoid accidental starting. Be sure switch is in the locked or off position before inserting battery pack.** Carrying tools with your finger on the switch or inserting the battery pack into a tool with the switch on, invites accidents.

- **Remove adjusting keys or wrenches before turning the tool on.** A wrench or a key that is left attached to a rotating part of the tool may result in personal injury.
- **Do not overreach. Keep proper footing and balance at all times.** Proper footing and balance enables better control of the tool in unexpected situations. Do not use on a ladder or unstable support.
- **Use safety equipment. Always wear eye protection.** Dust mask, non-skid safety shoes, hard hat, or hearing protection must be used for appropriate conditions.
- **Do not wear loose clothing or jewelry. Contain long hair.** Loose clothes, jewelry, or long hair can be drawn into air vents.
- **Do not use on a ladder or unstable support.** Stable footing on a solid surface enables better control of the tool in unexpected situations.

TOOL USE AND CARE

- **Use clamps or other practical way to secure and support the workpiece to a stable platform.** Holding the work by hand or against your body is unstable and may lead to loss of control.
- **Do not force tool. Use the correct tool for your application.** The correct tool will do the job better and safer at the rate for which it is designed.
- **Do not use tool if switch does not turn it on or off.** A tool that cannot be controlled with the switch is dangerous and must be repaired.
- **Disconnect battery pack from tool or place the switch in the locked or off position before making any adjustments, changing accessories, or storing the tool.** Such preventive safety measures reduce risk of starting the tool accidentally.
- **Store idle tools out of reach of children and other untrained persons.** Tools are dangerous in the hands of untrained users.
- **When battery pack is not in use, keep it away from other metal objects like: paper clips, coins, keys, nails, screws, or other small metal objects that can make a connection from one terminal to another.** Shorting the battery terminals together may cause sparks, burns, or a fire.
- **Maintain tools with care. Keep cutting tools sharp and clean.** Properly maintained tools, with sharp cutting edges are less likely to bind and are easier to control.
- **Check for misalignment or binding of moving parts, breakage of parts, and any other condition that may affect the tool's operation. If damaged, have the tool serviced before using.** Many accidents are caused by poorly maintained tools.
- **Use only accessories that are recommended by the manufacturer for your model.** Accessories that may be suitable for one tool, may create a risk of injury when used on another tool.
- **Keep the tool and its handle dry, clean and free from oil and grease.** Always use a clean cloth when cleaning. Never use brake fluids, gasoline, petroleum-based products, or any strong solvents to clean your tool.

GENERAL SAFETY RULES

SERVICE

- Tool service must be performed only by qualified repair personnel. Service or maintenance performed by unqualified personnel may result in a risk of injury.
- When servicing a tool, **use only identical replacement parts.** Follow instructions in the Maintenance section of this manual. Use of unauthorized parts or failure to follow Maintenance Instructions may create a risk of shock or injury.

SPECIFIC SAFETY RULES

- **Hold tool by insulated gripping surfaces when performing an operation where the cutting tool may contact hidden wiring.** Contact with a “live” wire will also make exposed metal parts of the tool “live” and shock the operator.

ADDITIONAL RULES FOR SAFE OPERATION

- **Know your power tool. Read operator’s manual carefully. Learn its applications and limitations, as well as the specific potential hazards related to this tool.** Following this rule will reduce the risk of electric shock, fire, or serious injury.
- **Always wear safety glasses with side shields.** Everyday glasses have only impact resistant lenses. They are NOT safety glasses. Following this rule will reduce the risk of eye injury.

RULES FOR BATTERY TOOLS

- Battery tools do not have to be plugged into an electrical outlet; therefore, they are always in operating condition. Be aware of possible hazards when not using your battery tool or when changing accessories. Following this rule will reduce the risk of electric shock, fire, or serious personal injury.

- **Do not place battery tools or their batteries near fire or heat.** This will reduce the risk of explosion and possibly injury.
- Batteries vent hydrogen gas and can explode in the presence of a source of ignition, such as a pilot light. To reduce the risk of serious personal injury, never use any cordless product in the presence of open flame. An exploded battery can propel debris and chemicals. If exposed, flush with water immediately.
- **Do not charge battery tool in a damp or wet location.** Following this rule will reduce the risk of electric shock.
- **For best results, your battery tool should be charged in a location where the temperature is more than 50°F but less than 100°F. Do not store outside or in vehicles.**
- **Under extreme usage or temperature conditions, battery leakage may occur. If liquid comes in contact with your skin, wash immediately with soap and water, then neutralize with lemon juice or vinegar. If liquid gets into your eyes, flush them with clean water for at least 10 minutes, then seek immediate medical attention.** Following this rule will reduce the risk of serious personal injury.

SAFETY INSTRUCTIONS FOR CHARGER

⚠ WARNING! Read and understand all instructions. Failure to follow all instructions listed below, may result in electric shock, fire and/or serious personal injury.

- Before using battery charger, read all instructions and cautionary markings in this manual, on battery charger, battery, and product using battery to prevent misuse of the products and possible injury or damage.

CAUTION: To reduce the risk of electric shock or damage to the charger and battery, charge only nickel-cadmium rechargeable batteries as specifically designated on your charger. Other types of batteries may burst, causing personal injury or damage.

- Never use a battery that has been dropped or received a sharp blow. A damaged battery is subject to explosion. Properly dispose of a dropped or damaged battery immediately.
- **Do not expose charger to wet or damp conditions.** Water entering charger will increase the risk of electric shock.
- Do not use any attachment or accessory not recommended by the battery charger manufacturer. Attachments and accessories that may be suitable for one tool may become hazardous when used on another tool.
- **Do not abuse cord or charger. Never use the cord to carry the charger.** Do not pull the charger cord rather than the plug when disconnecting from receptacle. Damage to the cord or charger could occur and create an electric shock hazard. Replace damaged cords immediately.
- Make sure cord is located so that it will not be stepped on, tripped over, come in contact with sharp edges or moving parts or otherwise subjected to damage or stress. This will reduce the risk of accidental falls, which could cause injury, and damage to the cord, which could result in electric shock.
- Keep cord and charger from heat to prevent damage to housing or internal parts.

- Do not let gasoline, oils, petroleum-based products, etc. come in contact with plastic parts. They contain chemicals that can damage, weaken, or destroy plastic.

- **An extension cord should not be used unless absolutely necessary.** Use of improper extension cord could result in a risk of fire and electric shock. If extension cord must be used, make sure:

- a. That pins on plug of extension cord are the same number, size and shape as those of plug on charger.
- b. That extension cord is properly wired and in good electrical condition; and
- c. That wire size is large enough for AC ampere rating of charger as specified below:

Cord Length (Feet)	25'	50'	100'
Cord Size (AWG)	16	16	16

Note: AWG = American Wire Gage

- Do not operate charger with a damaged cord or plug, which could cause shorting and electric shock. If damaged, have the charger replaced by an authorized serviceman.
- **Do not operate charger if it has received a sharp blow, been dropped, or otherwise damaged in any way.** Take it to an authorized serviceman for electrical check to determine if the charger is in good working order.
- **Do not disassemble charger. Take it to an authorized serviceman when service or repair is required. Incorrect reassembly may result in a risk of electric shock or fire.**
- Unplug charger from outlet before attempting any maintenance or cleaning to reduce the risk of electric shock.
- **Disconnect charger from the power supply when not in use.** This will reduce the risk of electric shock or damage to the charger if metal items should fall into the opening. It also will help prevent damage to the charger during a power surge.
- **Save these instructions.** Refer to them frequently and use them to instruct others who may use this tool. If you loan someone this tool, loan them these instructions also to prevent misuse of the product and possible injury.









⚠ WARNING: Some dust created by power sanding, sawing, grinding, drilling, and other construction activities contains chemicals known to cause cancer, birth defects or other reproductive harm. Some examples of these chemicals are:

- lead from lead-based paints,
- crystalline silica from bricks and cement and other masonry products, and
- arsenic and chromium from chemically-treated lumber.

Your risk from these exposures varies, depending on how often you do this type of work. To reduce your exposure to these chemicals: work in a well ventilated area, and work with approved safety equipment, such as those dust masks that are specially designed to filter out microscopic particles.



SYMBOLS

Some of the following symbols may be used on this tool. Please study them and learn their meaning. Proper interpretation of these symbols will allow you to operate the tool better and safer.

SYMBOL	NAME	DESIGNATION/EXPLANATION
V	Volts	Voltage
A	Amperes	Current
Hz	Hertz	Frequency (cycles per second)
W	Watt	Power
min	Minutes	Time
~	Alternating Current	Type of current
≡	Direct Current	Type or a characteristic of current
n_0	No Load Speed	Rotational speed, at no load
	Class II Construction	Double-insulated construction
.../min	Per Minute	Revolutions, strokes, surface speed, orbits etc., per minute
	Wet Conditions Alert	Do not expose to rain or use in damp locations.
	Read The Operator's Manual	To reduce the risk of injury, user must read and understand operator's manual before using this product.
	Eye Protection	Always wear safety goggles or safety glasses with side shields and a full face shield when operating this product.
	Safety Alert	Precautions that involve your safety.
	No Hands Symbol	Failure to keep your hands away from the blade will result in serious personal injury.
	No Hands Symbol	Failure to keep your hands away from the blade will result in serious personal injury.
	No Hands Symbol	Failure to keep your hands away from the blade will result in serious personal injury.
	No Hands Symbol	Failure to keep your hands away from the blade will result in serious personal injury.

SYMBOLS

The following signal words and meanings are intended to explain the levels of risk associated with this product.

SYMBOL	SIGNAL	MEANING
	DANGER:	Indicates an imminently hazardous situation, which, if not avoided, will result in death or serious injury.
	WARNING:	Indicates a potentially hazardous situation, which, if not avoided, could result in death or serious injury.
	CAUTION:	Indicates a potentially hazardous situation, which, if not avoided, may result in minor or moderate injury.
	CAUTION:	(Without Safety Alert Symbol) Indicates a situation that may result in property damage.

SERVICE

Servicing requires extreme care and knowledge and should be performed only by a qualified service technician. For service we suggest you return the product to your nearest **AUTHORIZED SERVICE CENTER** for repair. When servicing, use only identical replacement parts.



WARNING:

Observe all normal safety precautions related to avoiding electrical shock.



WARNING:

To avoid serious personal injury, do not attempt to use this product until you read thoroughly and understand completely the operator's manual. Save this operator's manual and review frequently for continuing safe operation and instructing others who may use this product.



WARNING:



The operation of any power tool can result in foreign objects being thrown into your eyes, which can result in severe eye damage. Before beginning power tool operation, always wear safety goggles or safety glasses with side shields and a full face shield when needed. We recommend Wide Vision Safety Mask for use over eyeglasses or standard safety glasses with side shields. Always use eye protection which is marked to comply with ANSI Z87.1.

SAVE THESE INSTRUCTIONS

FEATURES

SPECIFICATIONS

Chuck	1/2 in. Keyless
Motor	19.2 Volt DC
Switch.....	Variable Speed
Gear Train	2 Speed
No Load Speed	0-400/0-1400/min.
Clutch	24 Positions
Charger Input	120 V. 60 Hz, AC only
Charge Rate	1 Hour
Torque.....	410 in.lb.

KNOW YOUR DRILL-DRIVER

See Figure 1.

Before attempting to use your drill-driver, familiarize yourself with all operating features and safety requirements.

 **WARNING:** Do not allow familiarity with your drill-driver to make you careless. Remember that a care-less fraction of a second is sufficient to inflict severe injury.

KEYLESS CHUCK

Your drill-driver has a keyless chuck that allows you to hand tighten or release drill bit in the chuck jaws.

SWITCH

To turn your drill-driver ON, depress the switch trigger. Release switch trigger to turn your drill-driver OFF.

SWITCH LOCK

The switch trigger can be locked in the OFF position. This feature helps reduce the possibility of accidental starting when not in use.

VARIABLE SPEED

This tool has a variable speed switch that delivers higher speed with increased trigger pressure. Speed is controlled by the amount of switch trigger depression.

TWO SPEED GEAR TRAIN

Your drill-driver has a two speed gear train designed for drilling or driving at HI or LO speeds. A slide switch is located on top of your drill to select either HI or LO speed.

FORWARD/REVERSE SELECTOR

(DIRECTION OF ROTATION SELECTOR)

Your drill-driver has a forward/reverse selector located above the switch trigger.

WRIST STRAP

A wrist strap is provided to reduce the chances of dropping your drill-driver. Place one hand through the wrist strap when carrying tool.

BIT STORAGE

When not in use, bits provided with your drill-driver can be placed in the storage area located on the bottom of the motor housing.

LEVEL

To keep drill bit level during drilling operations, a level is located on the top and end of the motor housing.

 **WARNING:** If any parts are missing, do not operate your drill-driver until the missing parts are replaced. Failure to do so could result in possible serious personal injury.

FEATURES

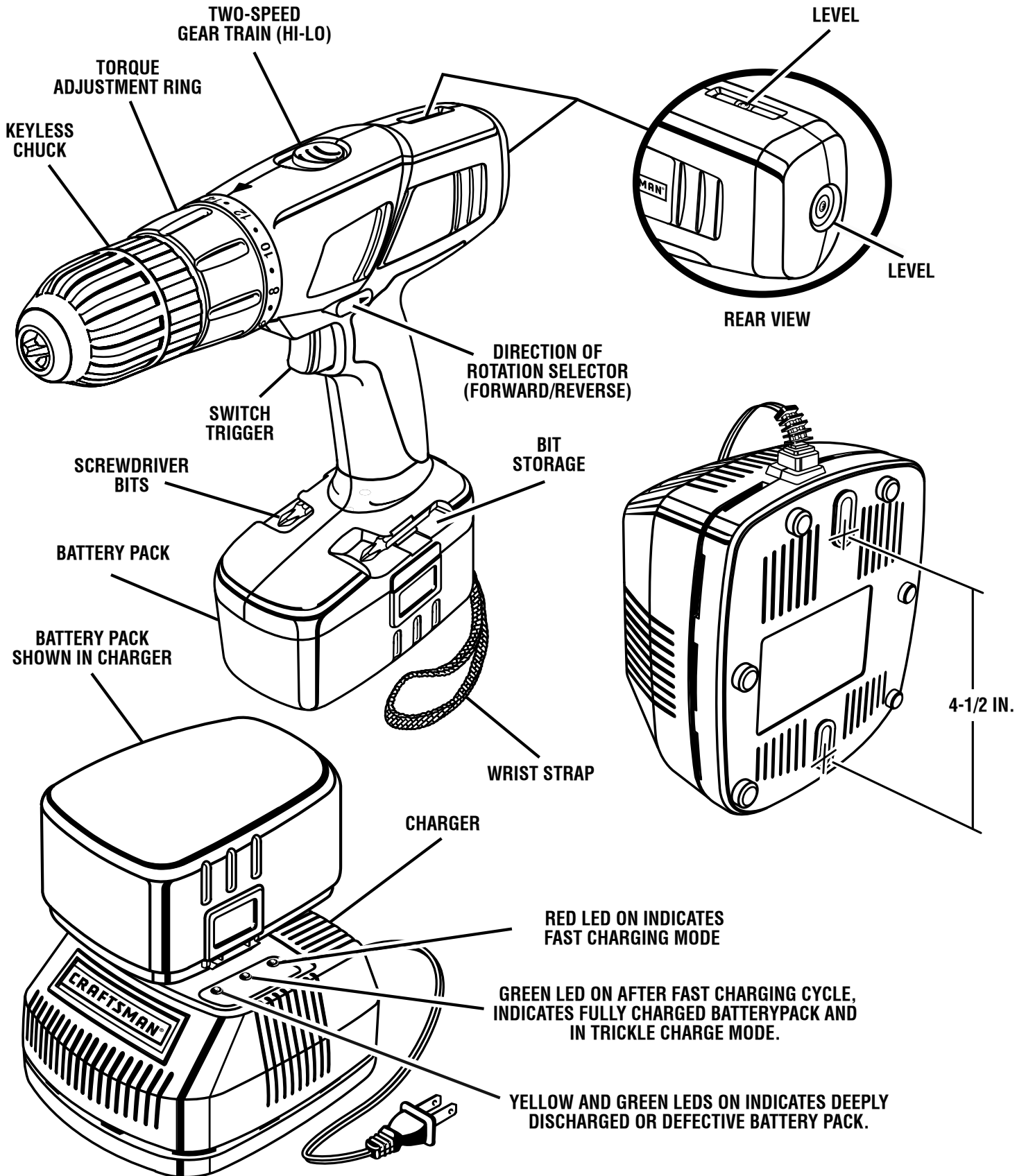

Fig. 1

UNPACKING

INSTRUCTIONS

When unpacking the tool:

- Carefully remove the tool and accessories from the box.
- Make sure that all items listed in the packing list are included.
- Inspect the tool carefully to make sure no breakage or damage occurred during shipping.
- Do not discard the packing material until you have carefully inspected and satisfactorily operated the tool.
- If any parts are damaged or missing, please call 1-800-932-3188 for assistance.

PACKING LIST

1/2 in. Drill
1 Hour Charger
Battery Pack (2)
Double-ended Bit (2)
Operator's Manual
Case



WARNING: If any parts are missing do not operate the tool until the missing parts are replaced. Failure to do so could result in possible serious personal injury.

OPERATION

⚠ WARNING: Do not allow familiarity with tools make you careless. Remember that a careless fraction of a second is sufficient to inflict severe injury.

BATTERY PACK

The battery pack for your tool has been shipped in a low charge condition to prevent possible problems. Therefore, you should charge it until light on front of charger changes from red to green.

Note: Batteries will not reach full charge the first time they are charged. Allow several cycles (drilling followed by recharging) for them to become fully charged.

CHARGING BATTERY PACK

See Figure 1.

- Charge battery pack only with the charger provided.
- Make sure power supply is normal household voltage, 120 volts, 60 Hz, AC only.
- Connect charger to power supply.
- Place battery pack in charger aligning raised rib on battery pack with groove in charger. See Figure 1.
- Press down on battery pack to be sure contacts on battery pack engage properly with contacts in charger.
- Normally, the red LED on charger will come on. This indicates charger is in fast charging mode.
- Red LED should remain on for approximately 1 hour then the green LED will come on. Green LED on indicates battery pack is fully charged and charger is in trickle charge mode. Note: Green LED will remain on until battery pack is removed from charger or charger is disconnected from power supply.
- If both yellow and green LED come on, this indicates a deeply discharged or defective battery pack.
- Allow battery pack to remain in charger for 15 to 30 minutes. When battery pack reaches normal voltage range, red LED should come on.
- If red LED does not come on after 30 minutes, this indicates a defective battery pack and should be replaced.
- After normal usage, a minimum of 1 hour of charging time is required to fully recharge battery pack.
- The battery pack will become slightly warm to the touch while charging. This is normal and does not indicate a problem.
- Do not place charger and battery pack in an area of extreme heat or cold. It will work best at normal room temperature.
Note: Charger and battery pack should be placed in a location where the temperature is more than 50°F but less than 100°F.
- When batteries become fully charged, unplug charger from power supply and remove the battery pack.

LED FUNCTIONS OF CHARGER LED WILL BE ON TO INDICATE STATUS OF CHARGER AND BATTERY PACK:

- Red LED on = Fast charging mode.
- Green LED on = Fully charged and in trickle charge mode.
- Green LED on = When battery pack is inserted into charger, indicates hot battery pack or that battery pack is out of or below normal temperature range.
- Yellow and Green LEDs on = Deeply discharged or defective battery pack.
- No LED on = Defective charger or battery pack.

CAUTION: To prevent damage to battery pack, remove battery pack from charger immediately if no LED comes on. Return battery pack and charger to your nearest Sears Service Center for checking or replacing. Also, if you are removing battery pack from charger and no LEDs are on, return both battery pack and charger to your nearest Sears Service Center. Do not insert another battery pack into charger. A damaged charger may damage a battery pack.

INFORMATION FOR RECHARGING HOT BATTERY PACK

When using your drill-driver continuously, the batteries in your battery pack will become hot. You should let a hot battery pack cool down for approximately 30 minutes before attempting to recharge. When the battery pack becomes discharged and is hot, this will cause the green LED to come on instead of the red LED. After 30 minutes, reinsert battery pack in charger. If green LED continues to remain on, return battery pack to your nearest Sears Repair Center for checking or replacing.

Note: This situation only occurs when continuous use of your drill causes the batteries to become hot. It does not occur under normal circumstances. Refer to "CHARGING BATTERY PACK" for normal recharging of batteries. If the charger does not charge your battery pack under normal circumstances, return both the battery pack and charger to your nearest Sears Repair Center for electrical check.

INFORMATION FOR RECHARGING COOL BATTERY PACK

If battery pack is below normal temperature range, the green LED on charger will come on. Allow battery pack to reach normal temperature, then the red LED will come on.

Note: Refer to "CHARGING BATTERY PACK" for normal recharging of batteries. If the charger does not charge your battery pack under normal circumstances, return both the battery pack and charger to your nearest Sears Repair Center for electrical check.

OPERATION

SWITCH

See Figure 2.

To turn your drill **ON**, depress the switch trigger. To turn it **OFF**, release the switch trigger.

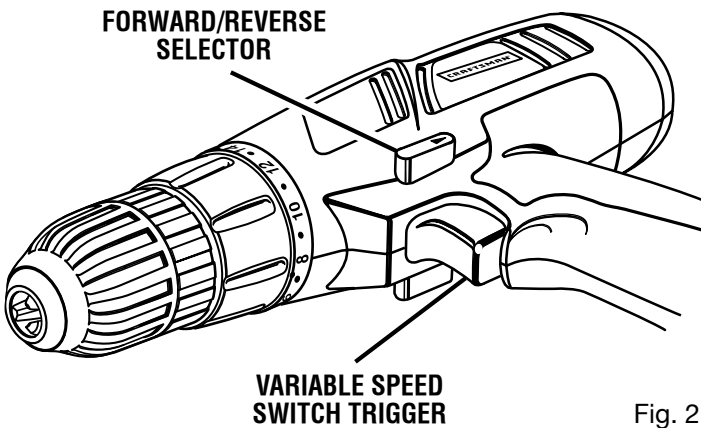

Fig. 2

VARIABLE SPEED

This tool has a variable speed switch that delivers higher speed and torque with increased trigger pressure. Speed is controlled by the amount of switch trigger depression.

Note: You might hear a whistling or ringing noise from the switch during use. Do not be concerned, this is a normal part of the switch function.

TWO-SPEED GEAR TRAIN

See Figure 3.

Your drill has a two-speed gear train designed for drilling or driving at LO (1) or HI (2) speeds. A slide switch is located on top of your drill to select either LO (1) or HI (2) speed. When using drill in the LO (1) speed range, speed will decrease and unit will have more power and torque. When using drill in the HI (2) speed range, speed will increase and unit will have less power and torque. Use LO (1) speed for high power and torque applications and HI (2) speed for fast drilling or driving applications.

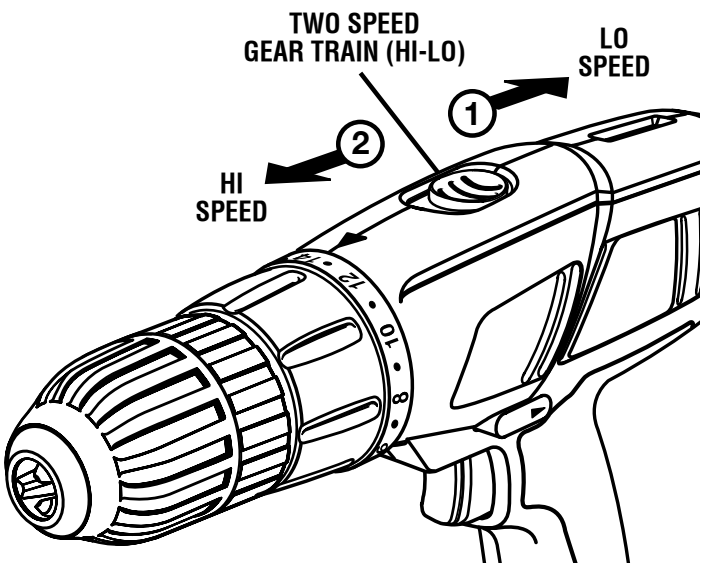

Fig. 3

TO INSTALL BATTERY PACK

- Lock switch trigger on your drill by placing the direction of rotation selector in center position. See Figure 5.
- Place battery pack in your drill. Align raised rib on battery pack with groove inside drill. See Figure 4.

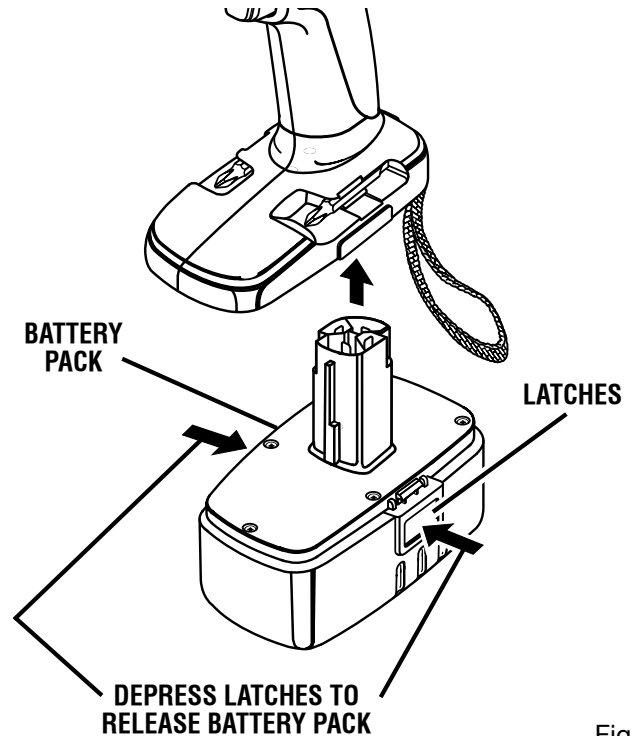

Fig. 4

- Make sure the latches on each side of your battery pack snap in place and battery pack is secured in drill before beginning operation.

CAUTION: When placing battery pack in your drill, be sure raised rib on battery pack aligns with groove inside drill and latches snap into place properly. Improper assembly of battery pack can cause damage to internal components.

TO REMOVE BATTERY PACK

- Lock switch trigger on your drill by placing the direction of rotation selector in center position. See Figure 5.
- Locate latches on side of battery pack and depress to release battery pack from your drill. See Figure 4.
- Remove battery pack from your drill.

OPERATION

SWITCH LOCK

See Figure 5.

The switch trigger can be locked in the **OFF** position. This feature can be used to prevent the possibility of accidental starting when not in use. To lock switch trigger, place the direction of rotation selector (Forward/Reverse Selector) in center position.

Note: When selector is in center position, switch trigger is locked.

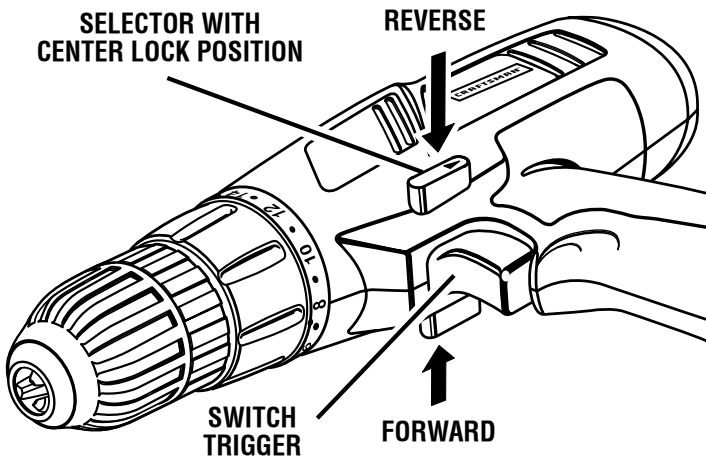

Fig. 5

⚠ WARNING: Battery tools are always in operating condition. Therefore, switch should always be locked when not in use or carrying at your side.

REVERSIBLE

See Figure 5.

This tool has the feature of being reversible. The direction of rotation is controlled by a selector located above the switch trigger. With the drill held in normal operating position, the direction of rotation selector should be positioned to the left of the switch for drilling. The drilling direction is reversed when the selector is to the right of the switch. When the selector is in center position, the switch trigger is locked.

CAUTION: To prevent gear damage, always allow chuck to come to a complete stop before changing the direction of rotation.

To stop, release switch trigger and allow the chuck to come to a complete stop.

KEYLESS CHUCK

See Figure 6.

Your drill has a keyless chuck. As the name implies, you can hand tighten or release drill bits in the chuck jaws. Grasp and hold the collar of the chuck with one hand. Rotate the chuck body with your other hand. The arrows on the chuck indicate which direction to rotate the chuck body in order to **LOCK** (tighten) or **UNLOCK** (release) the drill bit.

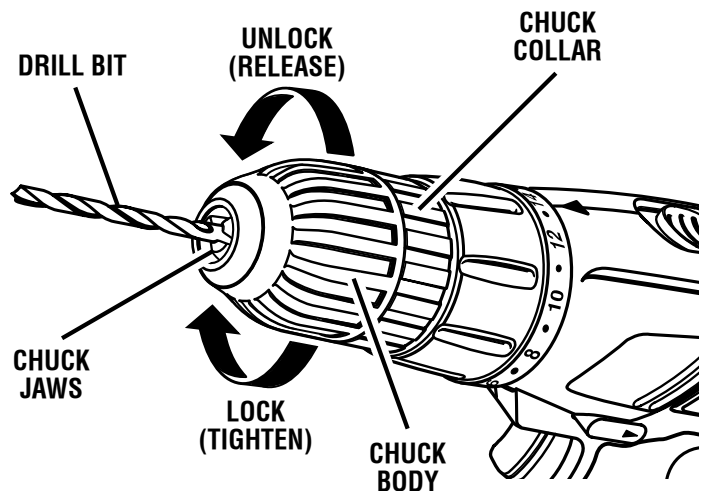

Fig. 6

⚠ WARNING: Do not hold chuck body with one hand and use power of the drill to tighten chuck jaws on drill bit. Chuck body could slip in your hand or your hand could slip and come in contact with rotating drill bit. This could cause an accident resulting in serious personal injury.

OPERATION

INSTALLING BITS

See Figure 7.

- Lock the switch trigger by placing the direction of rotation selector in center position. See Figure 5.
- Open or close chuck jaws to a point where the opening is slightly larger than the bit size you intend to use. Also, raise the front of your drill slightly to keep the bit from falling out of the chuck jaws.
- Insert drill bit straight into chuck the full length of the jaws as shown in figure 7.
- Tighten the chuck jaws on drill bit.

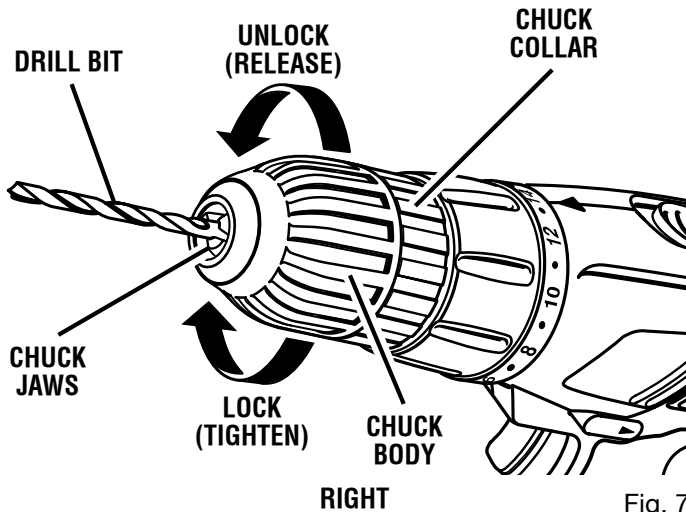

- To tighten the chuck jaws on drill bit; grasp and hold the collar of the chuck with one hand, while rotating the chuck body with your other hand.

Note: Rotate the chuck body in the direction of the arrow marked **LOCK** to tighten chuck jaws.

- **Do not** use a wrench to tighten or loosen the chuck jaws.

WARNING: Make sure to insert drill bit straight into chuck jaws. Do not insert drill bit into chuck jaws at an angle then tighten, as shown in figure 8. This could cause drill bit to be thrown from drill, resulting in possible serious personal injury or damage to the chuck.

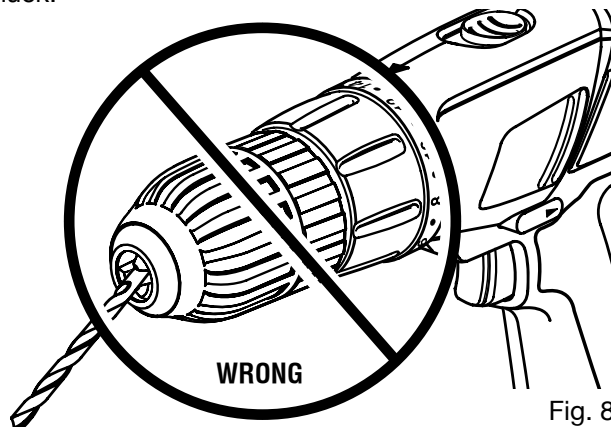

REMOVING BITS

See Figure 7.

- Lock the switch trigger by placing the direction of rotation selector in center position. See Figure 5.
- Loosen the chuck jaws from drill bit.
- To loosen: grasp and hold the collar of the chuck with one hand, while rotating chuck body with your other hand. **Note:** Rotate chuck body in the direction of the arrow marked **UNLOCK** to loosen chuck jaws.
- **Do not** use a wrench to tighten or loosen the chuck jaws.
- Remove drill bit from chuck jaws.

ADJUSTABLE TORQUE CLUTCH

Your drill is equipped with an adjustable torque clutch for driving different types of screws into different materials. The proper setting depends on the type of material and the size of screw you are using.

TO ADJUST TORQUE

- Identify the twenty four torque indicator settings located on the front of your drill. See Figure 9.
- Rotate adjusting ring to the desired setting.
 - 1 - 4 For driving small screws.
 - 5 - 8 For driving screws into soft material.
 - 9 - 12 For driving screws into soft and hard materials.
 - 13 - 16 For driving screws in hard wood.
 - 17 - 20 For driving large screws.
 - 21 -  For heavy drilling.

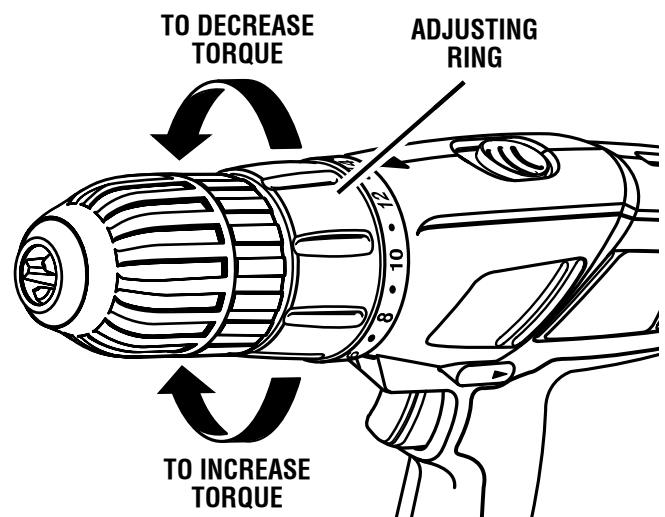

OPERATION

BIT STORAGE

See Figure 10.

When not in use, bits provided with your drill can be placed in the storage area located on the bottom of your drill as shown in figure 10.

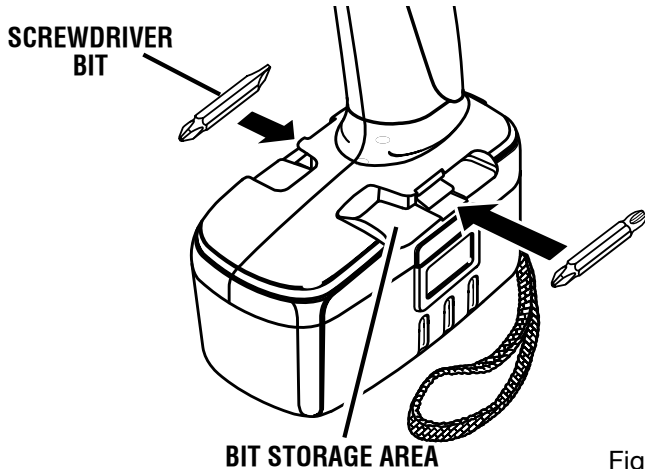

Fig. 10

WARNING: Always wear safety goggles or safety glasses with side shields when operating tools. Failure to do so could result in objects being thrown into your eyes, resulting in possible serious injury.

LEVEL

See Figure 11.

A convenient feature provided with your drill is a level. It is recessed in the motor housing on top and end of your drill. It can be used to keep drill bit level during drilling operations.

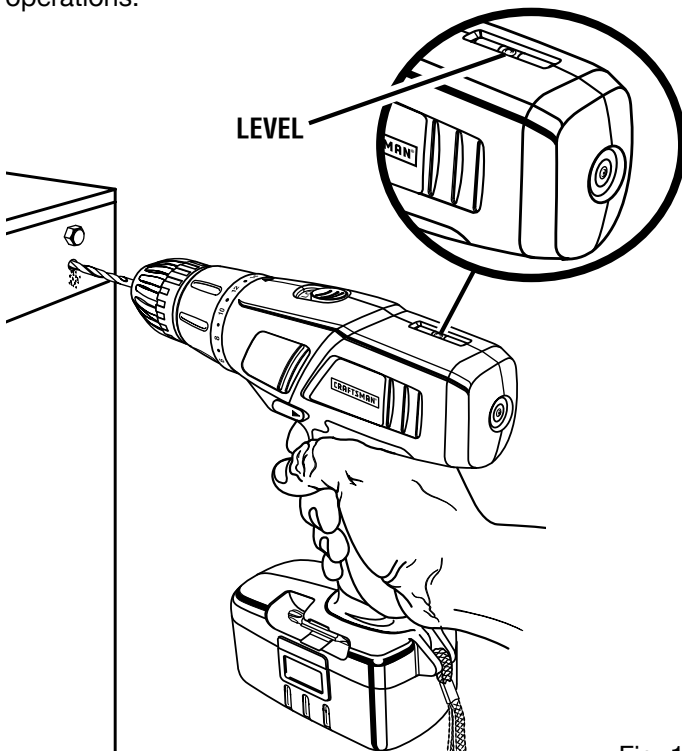

Fig. 11

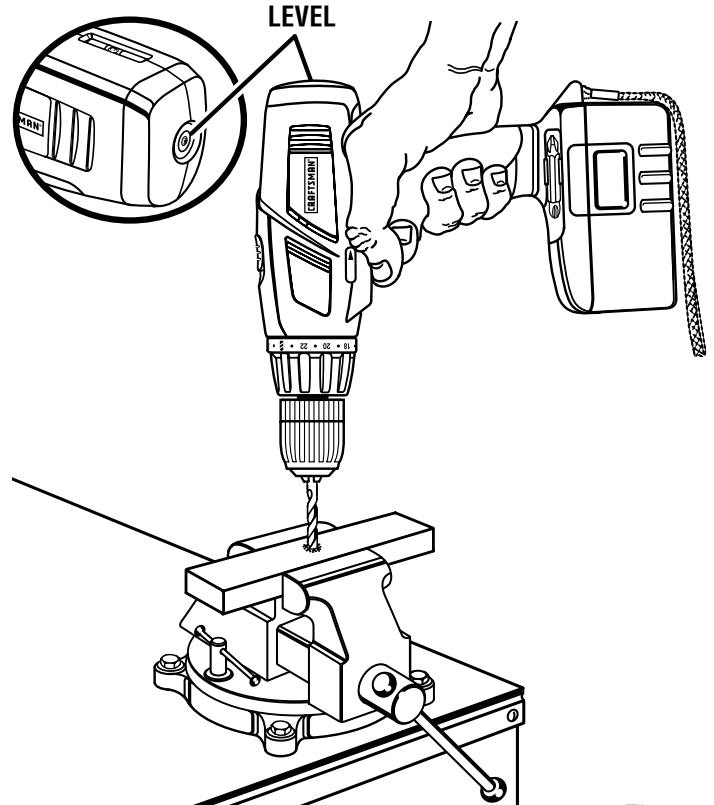

Fig. 12

DRILLING

See Figure 12.

When drilling hard smooth surfaces use a center punch to mark desired hole location. This will prevent the drill bit from slipping off center as the hole is started. However, the low speed feature allows starting holes without center punching if desired. To accomplish this, simply operate your drill at a low speed until the hole is started.

The material to be drilled should be secured in a vise or with clamps to keep it from turning as the drill bit rotates. Hold tool firmly and place the bit at the point to be drilled. Depress the switch trigger to start tool.

Move the drill bit into the workpiece applying only enough pressure to keep the bit cutting. Do not force or apply side pressure to elongate a hole.

WARNING: Be prepared for binding or bit breakthrough. When these situations occur, drill has a tendency to grab and kick opposite to the direction of rotation and could cause loss of control when breaking through material. If not prepared, this loss of control can result in possible serious injury.

When drilling metals, use a light oil on the drill bit to keep it from overheating. The oil will prolong the life of the bit and increase the drilling action.

If the bit jams in workpiece or if the drill stalls, release switch trigger immediately. Remove the bit from the workpiece and determine the reason for jamming.

OPERATION

CHUCK REMOVAL

See Figures 13, 14, and 15.

- Lock the switch trigger by placing the direction of rotation selector in center position. See Figure 5.
- Insert a 5/16 in. or larger hex key into the chuck of your drill and tighten the chuck jaws securely.
- Tap the hex key sharply with a mallet in a clockwise direction. See Figure 13. This will loosen the screw in the chuck for easy removal.

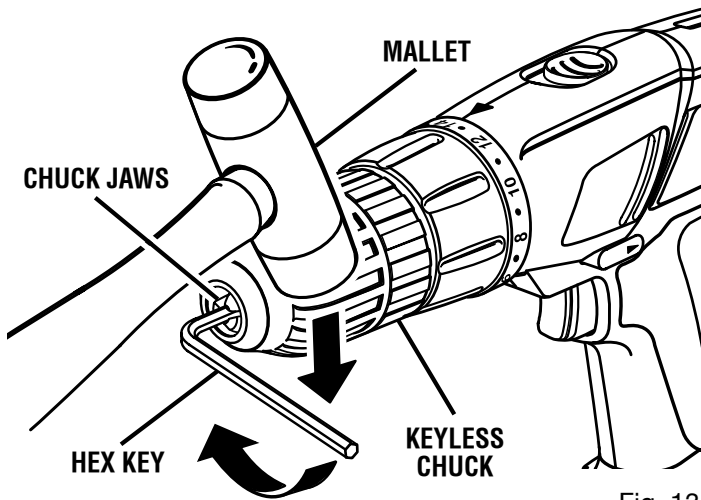

Fig. 13

- Open chuck jaws and remove hex key. Remove the chuck screw by turning it in a clockwise direction. See Figure 14.

Note: The screw has left hand threads.

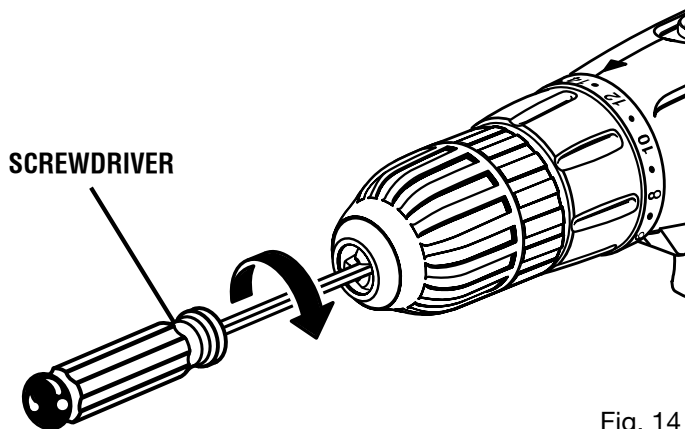

Fig. 14

- Insert hex key in chuck and tighten chuck jaws securely. Tap sharply with a mallet in a counterclockwise direction. This will loosen chuck on the spindle. It can now be unscrewed by hand. See Figure 15.

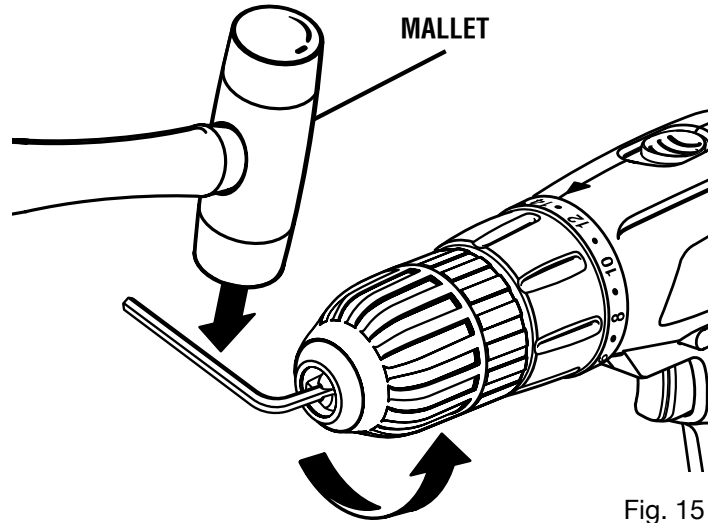

Fig. 15

TO RETIGHTEN A LOOSE CHUCK

The chuck may become loose on spindle and develop a wobble. Periodically check chuck screw for tightness.

To tighten, follow these steps:

- Lock the switch trigger by placing the direction of rotation selector in center position. See Figure 5.
- Open the chuck jaws.
- Insert hex key into chuck and tighten chuck jaws securely. Tap hex key sharply with a mallet in a clockwise direction. This will tighten chuck on the spindle.
- Open the chuck jaws and remove hex key.
- Tighten the chuck screw.

Note: The chuck screw has left hand threads.

MAINTENANCE

⚠ WARNING: When servicing, use only identical Craftsman replacement parts. Use of any other part may create a hazard or cause product damage.

Avoid using solvents when cleaning plastic parts. Most plastics are susceptible to damage from various types of commercial solvents and may be damaged by their use. Use clean cloths to remove dirt, dust, oil, grease, etc.

⚠ WARNING: Do not at any time let brake fluids, gasoline, petroleum-based products, penetrating oils, etc. come in contact with plastic parts. They contain chemicals that can damage, weaken or destroy plastic.

Do not abuse power tools. Abusive practices can damage tool as well as workpiece.

Only the parts shown on parts list, page 19, are intended to be repaired or replaced by the customer. All other parts should be replaced at a Sears Service Center.

⚠ WARNING: Do not attempt to modify this tool or create accessories not recommended for use with this tool. Any such alteration or modification is misuse and could result in a hazardous condition leading to possible serious personal injury.

BATTERIES

The battery pack for your drill-driver is equipped with nickel-cadmium rechargeable batteries. Length of service from each charging will depend on the type of work you are doing.

The batteries in this tool have been designed to provide maximum trouble free life. However, like all batteries, they will eventually wear out. Do not disassemble battery pack and attempt to replace the batteries. Handling of these batteries, especially when wearing rings and jewelry, could result in a serious burn.

To obtain the longest possible battery life, we suggest the following:

- Store and charge your batteries in a cool area. Temperatures below 50°F or above 100°F will shorten battery life.
- Never store batteries in a discharged condition. Recharge them immediately after they are discharged.
- All batteries gradually lose their charge. The higher the temperature the quicker they lose their charge. If you store your tool for long periods of time without using it, recharge the batteries every month or two. This practice will prolong battery life.



To preserve natural resources, please recycle or dispose of batteries properly.

This product contains nickel-cadmium batteries. Local, state or federal laws may prohibit disposal of nickel-cadmium batteries in ordinary trash.

Consult your local waste authority for information regarding available recycling and/or disposal options.

BATTERY PACK REMOVAL AND PREPARATION FOR RECYCLING

⚠ WARNING: Upon removal, cover the battery pack's terminals with heavy duty adhesive tape. Do not attempt to destroy or disassemble battery pack or remove any of its components. Nickel-cadmium batteries must be recycled or disposed of properly. Also, never touch both terminals with metal objects and/or body parts as short circuit may result. Keep away from children. Failure to comply with these warnings could result in fire and/or serious injury.

CRAFTSMAN 1/2 in., 19.2 VOLT CORDLESS DRILL-DRIVER – MODEL NO. 315.114850

The model number will be found on a plate attached to the motor housing. Always mention the model number in all correspondence regarding your 1/2 in., 19.2 VOLT CORDLESS DRILL-DRIVER or when ordering repair parts.

SEE BACK PAGE FOR PARTS ORDERING INSTRUCTIONS

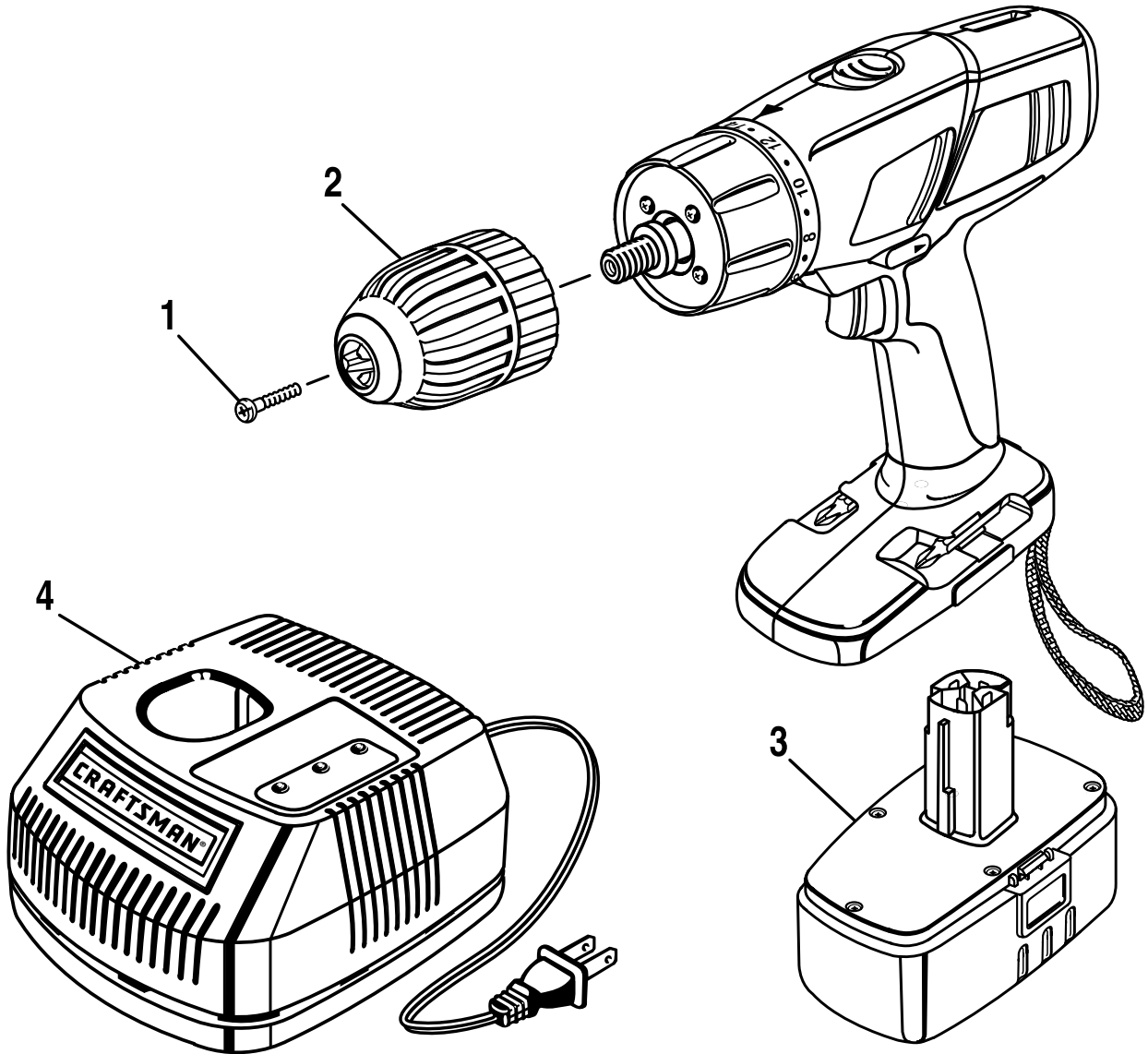

PARTS LIST

Key No.	Part Number	Description	Qty.
1	6613402	Screw (Special).....	1
2	6903323	Chuck	1
3	(1323517 or 1323903)	Battery Pack *Item No. 9 11375.....	1
4	(1425301)	Charger *Item No. 9 11041.....	1
	983000-464	Operator's Manual	

* Can Be Purchased Thru RSOS (Retail Special Order System)

Get it fixed, at your home or ours!

Your Home

For repair – **in your home** – of **all** major brand appliances, lawn and garden equipment, or heating and cooling systems, **no matter who made it, no matter who sold it!**

For the replacement parts, accessories and owner's manuals that you need to do-it-yourself.

For Sears professional installation of home appliances and items like garage door openers and water heaters.

1-800-4-MY-HOME® (1-800-469-4663)

Call anytime, day or night (U.S.A. and Canada)

www.sears.com www.sears.ca

Our Home

For repair of carry-in items like vacuums, lawn equipment, and electronics, call or go on-line for the location of your nearest **Sears Parts & Repair Center.**

1-800-488-1222

Call anytime, day or night (U.S.A. only)

www.sears.com

To purchase a protection agreement (U.S.A.) or maintenance agreement (Canada) on a product serviced by Sears:

1-800-827-6655 (U.S.A.)

1-800-361-6665 (Canada)

Para pedir servicio de reparación a domicilio, y para ordenar piezas:

1-888-SU-HOGARSM

(1-888-784-6427)

Au Canada pour service en français:

1-800-LE-FOYER^{MC}

(1-800-533-6937)

www.sears.ca

SEARS

OPERATOR'S MANUAL

CRAFTSMAN[®]

5-1/2 in., 19.2 VOLT CORDLESS LASER TRIM SAW

Model No.
315.115160

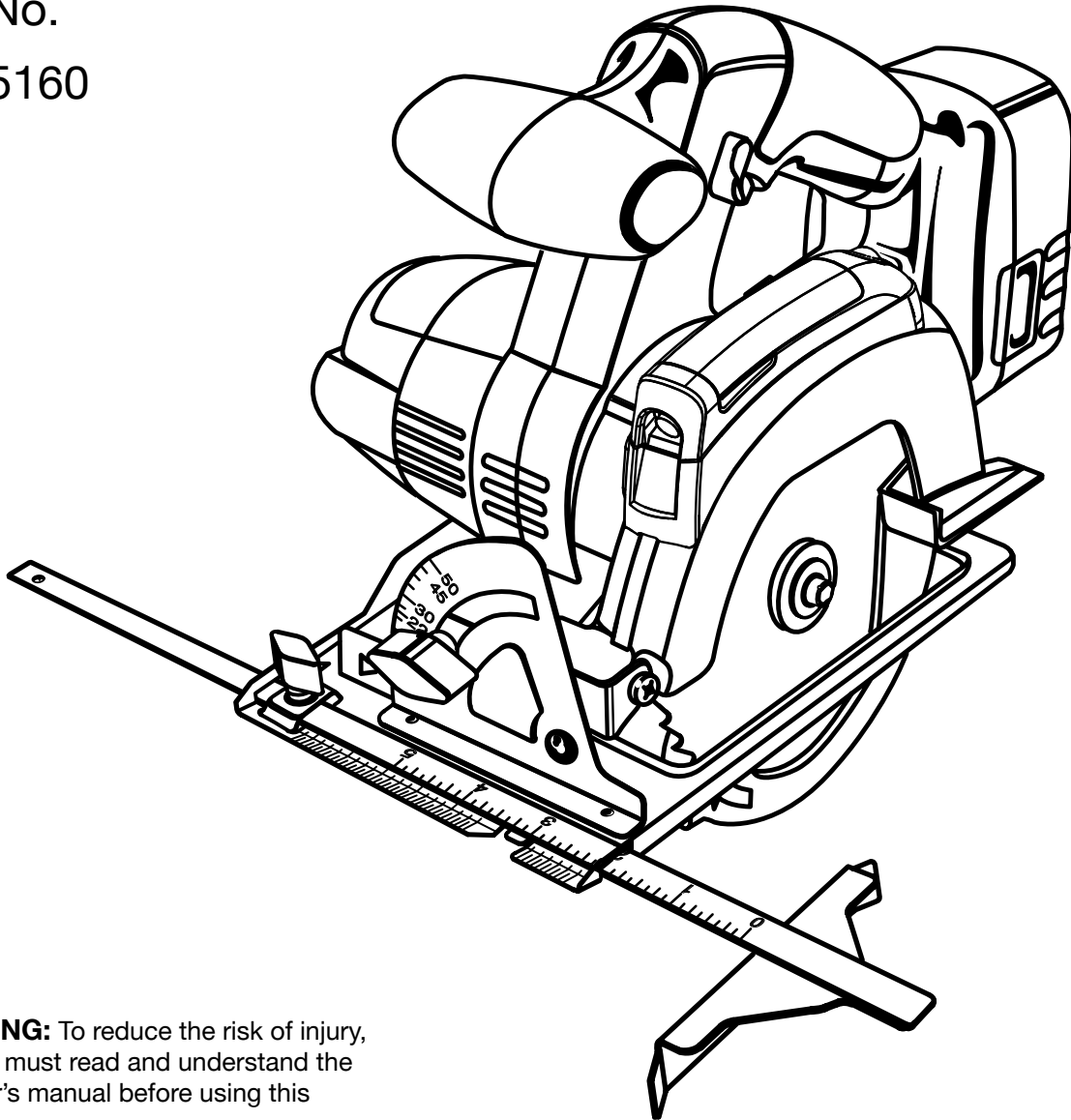

⚠ WARNING: To reduce the risk of injury, the user must read and understand the operator's manual before using this product.

Customer Help Line: 1-800-932-3188

Sears, Roebuck and Co., 3333 Beverly Rd., Hoffman Estates, IL 60179 USA
Visit the Craftsman web page: www.sears.com/craftsman

TABLE OF CONTENTS

■ Warranty	2
■ Introduction	2
■ General Safety Rules	3-4
■ Specific Safety Rules.....	4-5
■ Safety Rules for Charger	6
■ Symbols.....	7-8
■ Features.....	9-10
■ Assembly	10-12
■ Operation.....	13-22
■ Adjustments.....	22
■ Maintenance.....	23-24
■ Accessories	24
■ Exploded View and Repair Parts List	25-26
■ Parts Ordering / Service	Back Page

WARRANTY

ONE YEAR FULL WARRANTY ON CRAFTSMAN TOOL

If this Craftsman tool fails to give complete satisfaction within one year from date of purchase, **RETURN IT TO THE NEAREST SEARS STORE OR SEARS PARTS & REPAIR CENTER IN THE UNITED STATES**, and Sears will repair it, free of charge.

If this Craftsman tool is used for commercial or rental purposes, this warranty applies for only 90 days from the date of purchase.

This warranty gives you specific legal rights, and you may also have other rights which vary from state to state.

Sears, Roebuck and Co., Dept. 817WA, Hoffman Estates, IL 60179

INTRODUCTION

This tool has many features for making its use more pleasant and enjoyable. Safety, performance, and dependability have been given top priority in the design of this product making it easy to maintain and operate.

GENERAL SAFETY RULES

⚠ WARNING! READ AND UNDERSTAND ALL INSTRUCTIONS. Failure to follow all instructions listed below, may result in electric shock, fire and/or serious personal injury.

SAVE THESE INSTRUCTIONS

WORK AREA

- **Keep your work area clean and well lit.** Cluttered benches and dark areas invite accidents.
- **Do not operate power tools in explosive atmospheres, such as in the presence of flammable liquids, gases, or dust.** Power tools create sparks which may ignite the dust or fumes.
- **Keep bystanders, children, and visitors away while operating a power tool.** Distractions can cause you to lose control.

ELECTRICAL SAFETY

- **A battery operated tool with integral batteries or a separate battery pack must be recharged only with the specified charger for the battery.** A charger that may be suitable for one type of battery may create a risk of fire when used with another battery.
- **Use battery operated tool only with specifically designated battery pack.** Use of any other batteries may create a risk of fire.
- **Use battery only with charger listed.**

MODEL	BATTERY PACK	CHARGER
315.115160	Item No. 9 11375 (1323517 or 1323903)	Item No. 9 11041 (1425301)

- **Do not abuse the cord. Never use the cord to carry the charger. Keep cord away from heat, oil, sharp edges, or moving parts. Replace damaged cords immediately.** Damaged cords may create a fire.

PERSONAL SAFETY

- **Stay alert, watch what you are doing and use common sense when operating a power tool. Do not use tool while tired or under the influence of drugs, alcohol, or medication.** A moment of inattention while operating power tools may result in serious personal injury.
- **Dress properly. Do not wear loose clothing or jewelry. Contain long hair. Keep your hair, clothing, and gloves away from moving parts.** Loose clothes, jewelry, or long hair can be caught in moving parts.
- **Avoid accidental starting. Be sure switch is in the locked or off position before inserting battery pack.** Carrying tools with your finger on the switch or inserting the battery pack into a tool with the switch on invites accidents.
- **Remove adjusting keys or wrenches before turning the tool on.** A wrench or a key that is left attached to a rotating part of the tool may result in personal injury.

- **Do not overreach. Keep proper footing and balance at all times.** Proper footing and balance enable better control of the tool in unexpected situations.
- **Use safety equipment. Always wear eye protection.** Dust mask, non-skid safety shoes, hard hat, or hearing protection must be used for appropriate conditions.
- **Do not wear loose clothing or jewelry. Contain long hair.** Loose clothes, jewelry, or long hair can be drawn into air vents.
- **Do not use on a ladder or unstable support.** Stable footing on a solid surface enables better control of the tool in unexpected situations.

TOOL USE AND CARE

- **Use clamps or other practical way to secure and support the workpiece to a stable platform.** Holding the work by hand or against your body is unstable and may lead to loss of control.
- **Do not force tool. Use the correct tool for your application.** The correct tool will do the job better and safer at the rate for which it is designed.
- **Do not use tool if switch does not turn it on or off.** A tool that cannot be controlled with the switch is dangerous and must be repaired.
- **Disconnect battery pack from tool or place the switch in the locked or off position before making any adjustments, changing accessories, or storing the tool.** Such preventive safety measures reduce the risk of starting the tool accidentally.
- **Store idle tools out of reach of children and other untrained persons.** Tools are dangerous in the hands of untrained users.
- **When battery pack is not in use, keep it away from other metal objects like: paper clips, coins, keys, nails, screws, or other small metal objects that can make a connection from one terminal to another.** Shorting the battery terminals together may cause sparks, burns, or a fire.
- **Maintain tools with care. Keep cutting tools sharp and clean.** Properly maintained tools with sharp cutting edges are less likely to bind and are easier to control.
- **Check for misalignment or binding of moving parts, breakage of parts, and any other condition that may affect the tool's operation. If damaged, have the tool serviced before using.** Many accidents are caused by poorly maintained tools.
- **Use only accessories that are recommended by the manufacturer for your model.** Accessories that may be suitable for one tool may create a risk of injury when used on another tool.
- **Keep the tool and its handle dry, clean and free from oil and grease.** Always use a clean cloth when cleaning. Never use brake fluids, gasoline, petroleum-based products, or any strong solvents to clean your tool. Following this rule will reduce the risk of loss of control and deterioration of the enclosure plastic.

GENERAL SAFETY RULES

SERVICE

- **Tool service must be performed only by qualified repair personnel.** Service or maintenance performed by unqualified personnel may result in a risk of injury.
- **When servicing a tool, use only identical replacement parts. Follow instructions in the Maintenance section of this manual.** Use of unauthorized parts or failure to follow Maintenance Instructions may create a risk of shock or injury.

SPECIFIC SAFETY RULES

- **DANGER! Keep hands away from cutting area and blade. Keep your second hand on auxiliary handle or motor housing.** If both hands are holding the saw, they cannot be cut by the blade.
 - **Keep your body positioned to either side of the saw blade, but not in line with the saw blade.** KICKBACK could cause the saw to jump backwards. (see KICKBACK)
 - **Do not reach underneath the work.** The guard cannot protect you from the blade below the work.
 - **Check the lower guard for proper closing before each use. Do not operate saw if lower guard does not move freely and close instantly. Never clamp or tie the lower guard into the open position.** If saw is accidentally dropped, lower guard may be bent. Raise the lower guard with the retracting handle and make sure it moves freely and does not touch the blade or any other part, in all angles and depths of cut.
 - **Check the operation and condition of the lower guard spring. If the guard and the spring are not operating properly, they must be serviced before use.** Lower guard may operate sluggishly due to damaged parts, gummy deposits, or a buildup of debris.
 - **Lower guard should be retracted manually only for special cuts such as “Pocket Cuts” and “Compound Cuts”.** Raise lower guard by Retracting Handle. As soon as blade enters the material, lower guard must be released. For all other sawing, the lower guard should operate automatically.
 - **Always observe that the lower guard is covering the blade before placing saw down on bench or floor.** An unprotected, coasting blade will cause the saw to walk backwards, cutting whatever is in its path. Be aware of the time it takes for the blade to stop after switch is released.
 - **NEVER hold piece being cut in your hands or across your leg.** It is important to support the work properly to minimize body exposure, blade binding, or loss of control.
 - **Hold tool by insulated gripping surfaces when performing an operation where the cutting tool may contact hidden wiring.** Contact with a “live” wire will also make exposed metal parts of the tool “live” and shock the operator.
 - **When ripping always use a rip fence or straight edge guide.** This improves the accuracy of cut and reduces the chance of blade binding.
 - **Always use blades with correct size and shape (diamond vs. round) arbor holes.** Blades that do not match the mounting hardware of the saw will run eccentrically, causing loss of control.
 - **Never use damaged or incorrect blade washers or bolts.** The blade washers and bolt were specially designed for your saw, for optimum performance and safety of operation.
- Causes and Operator Prevention of Kickback:**
- Kickback is a sudden reaction to a pinched, bound, or misaligned saw blade, causing an uncontrolled saw to lift up and out of the workpiece toward the operator.*
- When the blade is pinched or bound tightly by the kerf closing down, the blade stalls and the motor reaction drives the unit rapidly back toward the operator.*
- If the blade becomes twisted or misaligned in the cut, the teeth at the back edge of the blade can dig into the top surface of the wood causing the blade to climb out of the kerf and jump back toward the operator.*
- Kickback is a result of tool misuse and/or incorrect operating procedures or conditions and can be avoided by taking proper precautions as given below:*
- **Maintain a firm grip on the saw and position your body and arm in a way that allows you to resist KICKBACK forces.** KICKBACK forces can be controlled by the operator, if proper precautions are taken.
 - **When blade is binding, or when interrupting a cut for any reason, release the trigger and hold the saw motionless in the material until the blade comes to a complete stop. Never attempt to remove the saw from the work or pull the saw backward while the blade is in motion or KICKBACK may occur.** Investigate and take corrective actions to eliminate the cause of blade binding.
 - **When restarting a saw in the workpiece, center the saw blade in the kerf and check that teeth are not engaged into the material.** If saw blade is binding, it may walk up or KICKBACK from the workpiece as the saw is restarted.
 - **Support large panels to minimize the risk of blade pinching and KICKBACK.** Large panels tend to sag under their own weight. Supports must be placed under the panel on both sides, near the line of cut and near the edge of the panel.

SPECIFIC SAFETY RULES

- **Do not use dull or damaged blade.** Unsharpened or improperly set blades produce narrow kerf causing excessive friction, blade binding, and KICKBACK.
- **Blade depth and bevel adjusting locking levers must be tight and secure before making cut.** If blade adjustment shifts while cutting, it will cause binding and KICKBACK.
- **Use extra caution when making a “Pocket Cut” into existing walls or other blind areas.** The protruding blade may cut objects that can cause KICKBACK.
- **Know your power tool. Read operator’s manual carefully. Learn its applications and limitations, as well as the specific potential hazards related to this tool.** Following this rule will reduce the risk of electric shock, fire, or serious injury.
- **Always wear safety glasses with side shields.** Everyday glasses have only impact resistant lenses. They are NOT safety glasses. Following this rule will reduce the risk of eye injury.
- **Battery tools do not have to be plugged into an electrical outlet; therefore, they are always in operating condition. Be aware of possible hazards when not using your battery tool or when changing accessories.** Following this rule will reduce the risk of electric shock, fire, or serious personal injury.
- **Do not place battery tools or their batteries near fire or heat.** This will reduce the risk of explosion and possibly injury.
- **Never use a battery that has been dropped or received a sharp blow.** A damaged battery is subject to explosion. Properly dispose of a dropped or damaged battery immediately.
- **Batteries vent hydrogen gas and can explode in the presence of a source of ignition, such as a pilot light.** To reduce the risk of serious personal injury, never use any cordless product in the presence of open flame. An exploded battery can propel debris and chemicals. If exposed, flush with water immediately.
- **Do not charge battery tool in a damp or wet location.** Following this rule will reduce the risk of electric shock.
- **For best results, your battery tool should be charged in a location where the temperature is more than 50°F but less than 100°F. Do not store outside or in vehicles.**
- **Under extreme usage or temperature conditions, battery leakage may occur. If liquid comes in contact with your skin, wash immediately with soap and water, then neutralize with lemon juice or vinegar. If liquid gets into your eyes, flush them with clean water for at least 10 minutes, then seek immediate medical attention.** Following this rule will reduce the risk of serious personal injury.

Laser Guide Warnings:

The laser guide radiation used in the Craftsman trim saw is Class IIIa with maximum <5 mW and 650nm wavelengths. These lasers do not normally present an optical hazard although staring at the beam may cause flash blindness.

- **Avoid** direct eye exposure when using the laser guide.
- The laser shall be used and maintained in accordance with the manufacturer’s instructions.
- Never aim the beam at a person or object other than the workpiece.
- Always ensure the laser beam is aimed at a sturdy workpiece without reflective surfaces. Shiny reflective sheet metal or similar shiny materials are not suitable for laser use.
- All repairs should be made by an authorized service representative or the laser manufacturer.

SAFETY RULES FOR CHARGER

⚠ WARNING! READ AND UNDERSTAND ALL INSTRUCTIONS. Failure to follow all instructions listed below, may result in electric shock, fire and/or serious personal injury.

■ **Before using battery charger,** read all instructions and cautionary markings in this manual, on battery charger, battery, and product using battery to prevent misuse of the products and possible injury or damage.

⚠ CAUTION: To reduce the risk of electric shock or damage to the charger and battery, charge only nickel-cadmium rechargeable batteries as specifically designated on your charger. Other types of batteries may burst, causing personal injury or damage.

■ **Do not use charger outdoors or expose to wet or damp conditions.** Water entering charger will increase the risk of electric shock.

■ **Use of an attachment not recommended or sold by the battery charger manufacturer may result in a risk of fire, electric shock, or injury to persons.** Following this rule will reduce the risk of electric shock, fire, or serious personal injury.

■ **Do not abuse cord or charger.** Never use the cord to carry the charger. Do not pull the charger cord rather than the plug when disconnecting from receptacle. Damage to the cord or charger could occur and create an electric shock hazard. Replace damaged cords immediately.

■ **Make sure cord is located so that it will not be stepped on, tripped over, come in contact with sharp edges or moving parts or otherwise subjected to damage or stress.** This will reduce the risk of accidental falls, which could cause injury, and damage to the cord, which could result in electric shock.

■ **Keep cord and charger from heat to prevent damage to housing or internal parts.**

■ **Do not let gasoline, oils, petroleum-based products, etc. come in contact with plastic parts.** They contain chemicals that can damage, weaken, or destroy plastic.

■ **An extension cord should not be used unless absolutely necessary.** Use of improper extension cord could result in a risk of fire and electric shock. If extension cord must be used, make sure:

- That pins on plug of extension cord are the same number, size and shape as those of plug on charger.
- That extension cord is properly wired and in good electrical condition; and
- That wire size is large enough for AC ampere rating of charger as specified below:

Cord Length (Feet)	25'	50'	100'
Cord Size (AWG)	16	16	16

NOTE: AWG = American Wire Gauge

- **Do not operate charger with a damaged cord or plug,** which could cause shorting and electric shock. If damaged, have the charger replaced by an authorized serviceman.
- **Do not operate charger if it has received a sharp blow, been dropped, or otherwise damaged in any way.** Take it to an authorized serviceman for electrical check to determine if the charger is in good working order.
- **Do not disassemble charger.** Take it to an authorized serviceman when service or repair is required. Incorrect reassembly may result in a risk of electric shock or fire.
- **Unplug charger from outlet before attempting any maintenance or cleaning to reduce the risk of electric shock.**
- **Disconnect charger from the power supply when not in use.** This will reduce the risk of electric shock or damage to the charger if metal items should fall into the opening. It also will help prevent damage to the charger during a power surge.
- **Risk of electric shock.** Do not touch uninsulated portion of output connector or uninsulated battery terminal.
- **Save these instructions.** Refer to them frequently and use them to instruct others who may use this tool. If you loan someone this tool, loan them these instructions also to prevent misuse of the product and possible injury.











⚠ WARNING: Some dust created by power sanding, sawing, grinding, drilling, and other construction activities contains chemicals known to cause cancer, birth defects or other reproductive harm. Some examples of these chemicals are:

- lead from lead-based paints,
- crystalline silica from bricks and cement and other masonry products, and
- arsenic and chromium from chemically-treated lumber.

Your risk from these exposures varies, depending on how often you do this type of work. To reduce your exposure to these chemicals: work in a well ventilated area, and work with approved safety equipment, such as those dust masks that are specially designed to filter out microscopic particles.



SYMBOLS

Some of the following symbols may be used on this tool. Please study them and learn their meaning. Proper interpretation of these symbols will allow you to operate the tool better and safer.

SYMBOL	NAME	DESIGNATION/EXPLANATION
V	Volts	Voltage
A	Amperes	Current
Hz	Hertz	Frequency (cycles per second)
W	Watt	Power
min	Minutes	Time
~	Alternating Current	Type of current
==	Direct Current	Type or a characteristic of current
n ₀	No Load Speed	Rotational speed, at no load
	Class II Construction	Double-insulated construction
.../min	Per Minute	Revolutions, strokes, surface speed, orbits etc., per minute
	Wet Conditions Alert	Do not expose to rain or use in damp locations.
	Read The Operator's Manual	To reduce the risk of injury, user must read and understand operator's manual before using this product.
	Eye Protection	Always wear safety goggles or safety glasses with side shields and a full face shield when operating this product.
	Safety Alert	Precautions that involve your safety.
	No Hands Symbol	Failure to keep your hands away from the blade will result in serious personal injury.
	No Hands Symbol	Failure to keep your hands away from the blade will result in serious personal injury.
	No Hands Symbol	Failure to keep your hands away from the blade will result in serious personal injury.
	No Hands Symbol	Failure to keep your hands away from the blade will result in serious personal injury.
	Hot Surface	To reduce the risk of injury or damage, avoid contact with any hot surface.

SYMBOLS

The following signal words and meanings are intended to explain the levels of risk associated with this product.

SYMBOL	SIGNAL	MEANING
	DANGER:	Indicates an imminently hazardous situation, which, if not avoided, will result in death or serious injury.
	WARNING:	Indicates a potentially hazardous situation, which, if not avoided, could result in death or serious injury.
	CAUTION:	Indicates a potentially hazardous situation, which, if not avoided, may result in minor or moderate injury.
	CAUTION:	(Without Safety Alert Symbol) Indicates a situation that may result in property damage.

SERVICE

Servicing requires extreme care and knowledge and should be performed only by a qualified service technician. For service we suggest you return the product to your nearest **AUTHORIZED SERVICE CENTER** for repair. When servicing, use only identical replacement parts.

 **WARNING:** To avoid serious personal injury, do not attempt to use this product until you read thoroughly and understand completely the operator's manual. Save this operator's manual and review frequently for continuing safe operation and instructing others who may use this product.

WARNING:



The operation of any power tool can result in foreign objects being thrown into your eyes, which can result in severe eye damage. Before beginning power tool operation, always wear safety goggles or safety glasses with side shields and a full face shield when needed. We recommend Wide Vision Safety Mask for use over eyeglasses or standard safety glasses with side shields. Always use eye protection which is marked to comply with ANSI Z87.1.

SAVE THESE INSTRUCTIONS

FEATURES

PRODUCT SPECIFICATIONS

Motor.....	19.2 Volt DC
Blade diameter	5-1/2 in. (140 mm)
Blade Arbor	3/8 in. (9.53 mm)
Cutting Depth at 0°.....	1-9/16 in. (39.69 mm)
Cutting Depth at 45°.....	1-1/8 in. (28.58 mm)
No Load Speed	4500/min.
Charger Input	120 V, 60 Hz, AC only
Charge Rate	1 Hr.
Laser Guide.....	Class IIIa, <5 mW max, 650nm

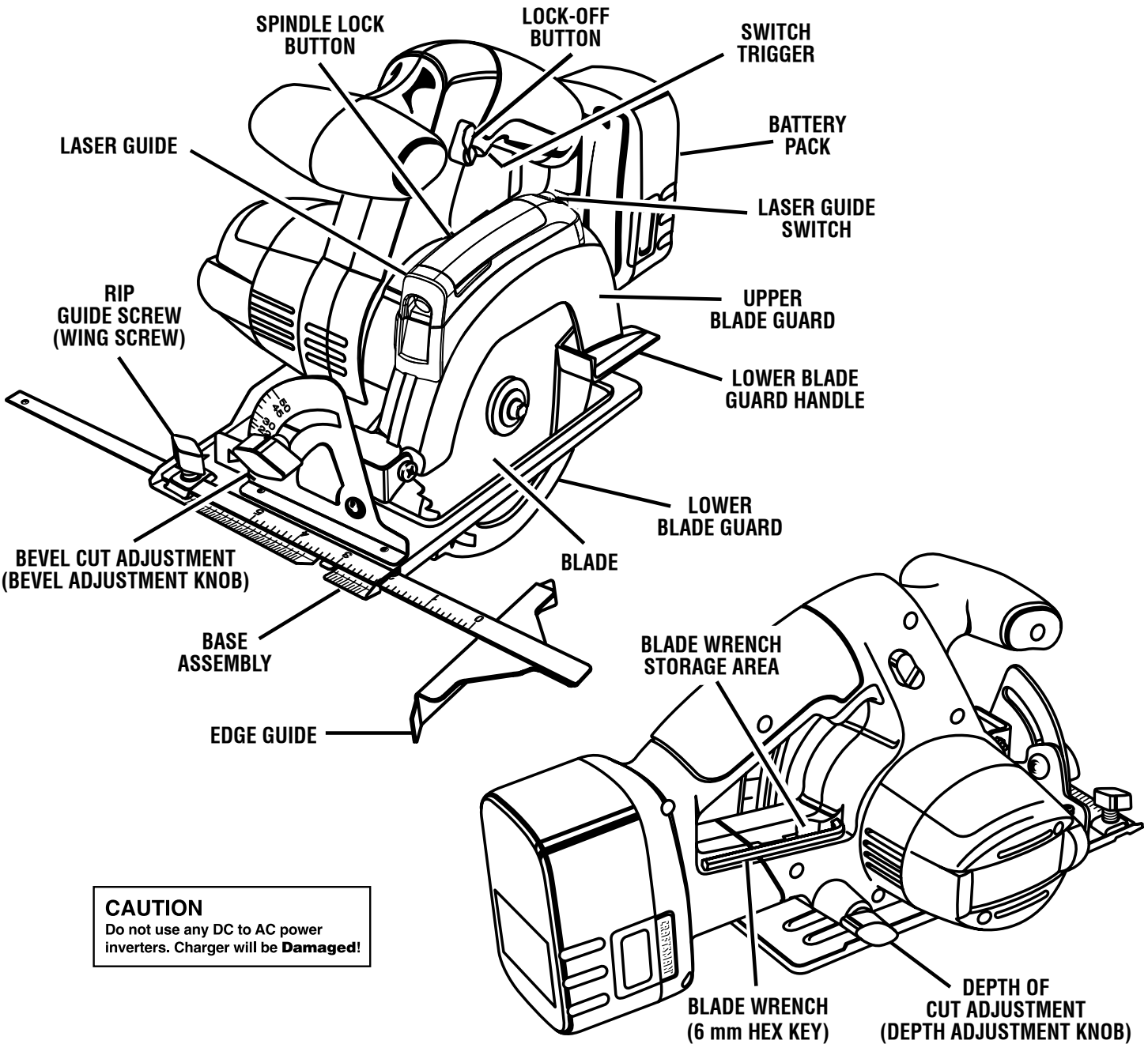

CAUTION
Do not use any DC to AC power inverters. Charger will be **Damaged!**

Fig.1

FEATURES

KNOW YOUR LASER TRIM SAW

See Figure 1.

Before attempting to use this product, familiarize yourself with all operating Features and Safety Rules

EDGE GUIDE

Edge guide is used when making long or wide rip cuts with the saw.

SWITCH TRIGGER

The trim saw is equipped with a pre-travel safety switch which reduces the possibility of accidental starting. When you depress the switch, the saw will not start until you reach the pre-travel position. You must depress the switch fully to activate the saw.

BLADE WRENCH STORAGE

Convenient wrench storage for quick blade changes.

DEPTH CUT

Adjusts the depth of cut from 0 in. to 1-9/16 in.

SPINDLE LOCK

The spindle lock allows you to secure the blade when turning the blade screw.

NOTE: Do not run trim saw with spindle lock engaged.

DUST CHUTE

To direct saw dust and chips away from the operator, a dust chute is located on the side of the upper blade guard.

ERGONOMIC DESIGN

The design of your trim saw provides for maintaining proper two hand control when cutting. It has been designed to be comfortable and easy to grasp.

LASER GUIDE

The laser guide will generate a red colored line on the work surface when turned on.

ASSEMBLY

UNPACKING

This product requires assembly.

- Carefully remove the tool and accessories from the box. Make sure that all items listed in the packing list are included.
- Inspect the tool carefully to make sure no breakage or damage occurred during shipping.
- Do not discard the packing material until you have carefully inspected and satisfactorily operated the tool.
- If any parts are damaged or missing, please call 1-800-932-3188 for assistance.

PACKING LIST

Cordless Trim Saw with Laser
5-1/2 in. (140 mm) Blade
Battery Pack
Laser Batteries
Charger
Edge Guide
Blade Wrench
Operator's Manual

WARNING: If any parts are missing do not operate the tool until the missing parts are replaced. Failure to do so could result in possible serious personal injury.

WARNING: Do not attempt to modify this tool or create accessories not recommended for use with this tool. Any such alteration or modification is misuse and could result in a hazardous condition leading to possible serious personal injury.

WARNING: To prevent accidental starting that could cause serious personal injury, always remove the battery pack from the tool when assembling parts.

REMOVING BATTERY PACK

See Figure 2.

- Locate latches on side of battery pack and depress to release battery pack from your saw.
- Remove battery pack from your saw.

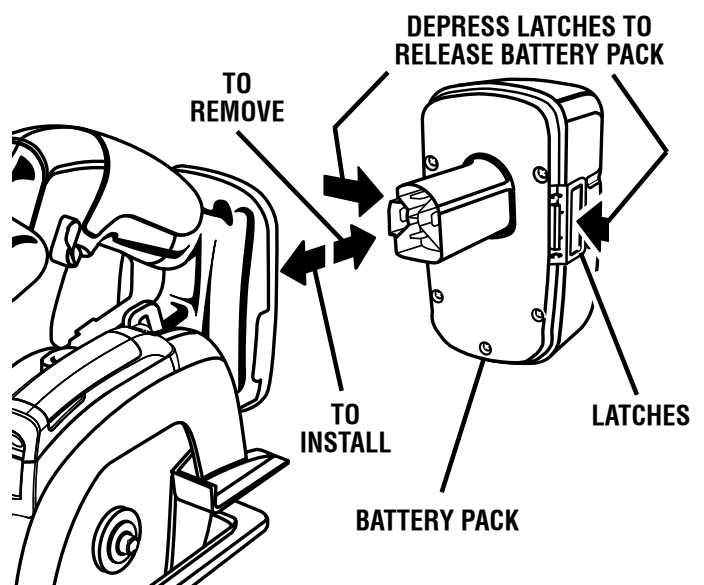

Fig. 2

ASSEMBLY

INSTALLING BATTERY PACK

See Figure 3.

NOTE: Battery pack is shipped in a low charge condition. Therefore, it must be charged prior to use. Refer to page 13, “**CHARGING BATTERY PACK**” for charging instructions.

- Place battery pack in your saw. Align raised rib on battery pack with groove inside saw, then slide battery pack in saw as shown in figure 5.
- Make sure the latches on each side of your battery pack snap into place and battery pack is secured in saw before beginning operation.

CAUTION: When placing battery pack in your saw, be sure raised rib on battery pack aligns with groove inside saw and latches snap into place properly. Improper assembly can cause damage to saw and battery pack.

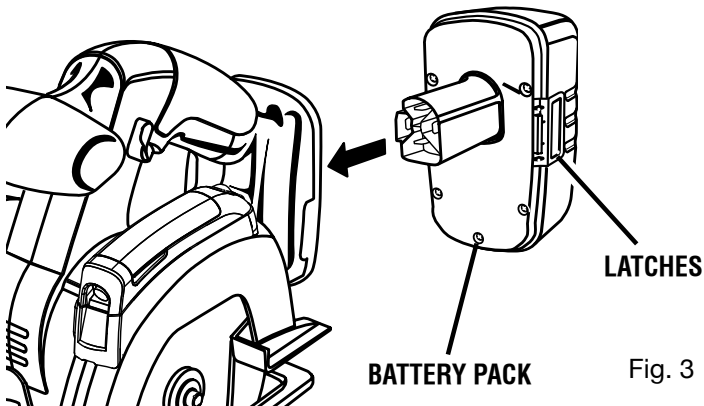

ATTACHING BLADE

See Figure 4.

WARNING: A 5-1/2 in. (140 mm) blade is the maximum blade capacity of your saw. Never use a blade that is too thick to allow outer blade washer to engage with the flats on the spindle. Larger blades will come in contact with the blade guard, while thicker blades will prevent blade screw from securing blade on spindle. Either of these situations could result in a serious accident.

- Remove battery pack from saw.
- Locate latches on side of battery pack and depress to release battery pack from your saw.
- Remove blade wrench (6 mm hex key) from storage area.

- Depress spindle lock button and remove blade screw and outer blade washer.
NOTE: Turn blade screw clockwise to remove.
- Wipe a drop of oil onto inner blade washer and outer blade washer where they contact blade.

WARNING: If inner blade washer has been removed, replace it before placing blade on spindle. Failure to do so could cause an accident since blade will not tighten properly.

- Fit saw blade inside lower blade guard and onto spindle.
NOTE: The saw teeth point upward at the front of saw as shown in figure 3.
- Replace outer blade washer.
- Depress spindle lock button, then replace blade screw. Tighten blade screw securely.
NOTE: Turn blade screw counterclockwise to tighten.
- Return blade wrench to storage area.

NOTE: Never use a blade that is too thick to allow the outer blade washer to engage with the flats on the spindle.

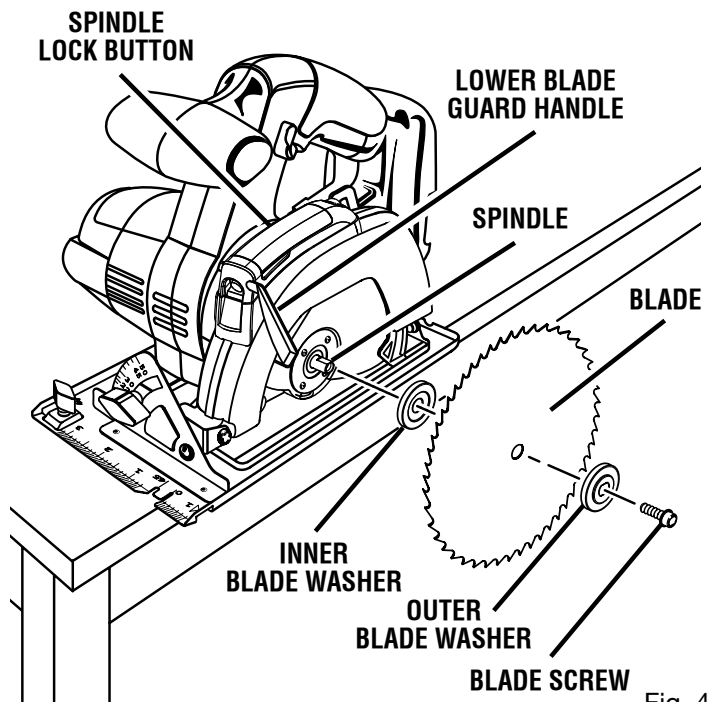

ASSEMBLY

REMOVING BLADE

See Figure 5.

- Remove battery pack from saw.
- Remove blade wrench from storage area.
- Position saw as shown in figure 5, depress spindle lock button, and remove blade screw.

NOTE: Turn blade screw clockwise to remove.

- Remove outer blade washer.

NOTE: Blade can be removed at this point.

⚠ WARNING: Current attachments and accessories available for use with this tool are listed above. Do not use any attachments or accessories not recommended by the manufacturer of this tool. The use of attachments or accessories not recommended can result in serious personal injury.

EDGE GUIDE

Use the edge guide provided with your saw when making wide rip cuts. A five inch scale has been provided on the edge guide. When using the width of cut scale on the base in combination with the edge guide, cuts can be made up to 6 in. to the left of the edge guide or 8-7/8 in. to the right of the edge guide.

The edge guide helps prevent the blade from twisting in a cut. The blade twisting in a cut can cause kickback.

INSTALLING EDGE GUIDE

See Figure 6.

- Remove battery pack from saw.
- Place edge guide through holes in saw base.
- Adjust edge guide to the width needed.
- Tighten edge guide screw (wing screw) securely.

NOTE: When using a edge guide, position the face of the edge guide firmly against the edge of workpiece. This makes for a true cut without pinching the blade. The guiding edge of workpiece must be straight for your cut to be straight. Use caution to prevent the blade from binding in the cut.

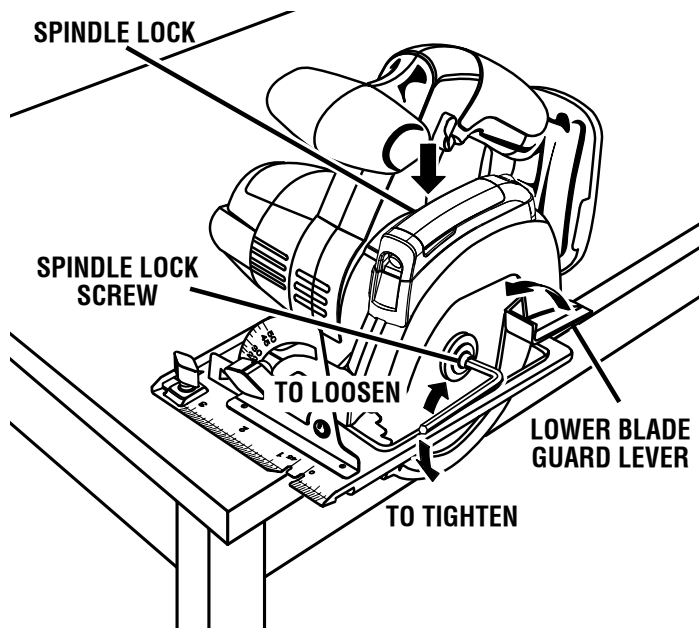

Fig. 5

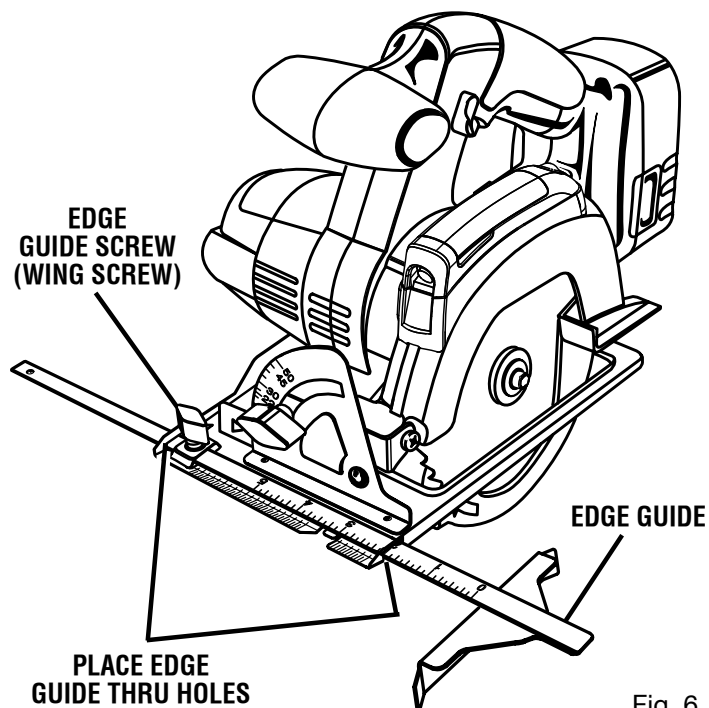

Fig. 6

OPERATION

WARNING: Do not allow familiarity with tools to make you careless. Remember that a careless fraction of a second is sufficient to inflict serious injury.

WARNING: Always wear safety goggles or safety glasses with side shields when operating tools. Failure to do so could result in objects being thrown into your eyes, resulting in possible serious injury.

APPLICATIONS

You may use this tool for the following purposes:

- Cutting all types of wood products (lumber, plywood, paneling).
- Cross Cutting/Rip Cutting
- Bevel Cutting
- Pocket Cutting

CAUTION: To prevent damage to the battery pack, remove the battery pack from the charger immediately if no LED comes on. Return the battery pack and charger to your nearest service center for checking or replacing. Also, if you are removing the battery pack from the charger and no LEDs are on, return both the battery pack and the charger to your nearest service center. Do not insert another battery pack into the charger. A damaged charger may damage a battery pack.

LED FUNCTIONS OF CHARGER

LED WILL BE ON TO INDICATE STATUS OF CHARGER AND BATTERY PACK:

- Red LED on = Fast charging mode.
- Green LED on = Fully charged and in trickle charge mode.
- Green LED on = When battery pack is inserted into charger, indicates hot battery pack or that battery pack is out of or below normal temperature range.
- Yellow and Green LEDs on = Deeply discharged or defective battery pack.
- No LED on = Defective charger or battery pack.

CHARGING THE BATTERY PACK

The battery pack for this tool has been shipped in a low charge condition to prevent possible problems. Therefore, you should charge it until the green LED on the front of the charger comes on.

NOTE: Batteries will not reach full charge the first time they are charged. Allow several cycles (operation followed by recharging) for them to become fully charged.

CHARGING A COOL BATTERY PACK

If battery pack is below normal temperature range, the green LED on charger will come on. Allow battery pack to reach normal temperature, then the red LED will come on.

NOTE: If the charger does not charge the battery pack under normal circumstances, return both the battery pack and charger to your nearest Sears Repair Center for electrical check.

- Charge the battery pack only with the charger provided.
- Make sure the power supply is normal household voltage, **120 volts, 60 Hz, AC only**.
- Connect the charger to the power supply.
- Place the battery pack in the charger aligning raised rib on the battery pack with the groove in the charger. *See Figure 7.*
- Press down on the battery pack to be sure contacts on the battery pack engage properly with contacts in the charger.
- Normally the red LED on charger will come on. This indicates the charger is in fast charging mode.
- Red LED should remain on for approximately 1 hour then the green LED will come on. Green LED on indicates battery pack is fully charged and charger is in maintenance charge mode.
- **NOTE:** The green LED will remain on until the battery pack is removed from the charger or charger is disconnected from the power supply.
- If both yellow and green LEDs come on, this indicates a deeply discharged or defective battery pack. Allow the battery pack to remain in the charger for 15 to 30 minutes. When the battery pack reaches normal voltage range, the red LED should come on. If the red LED does not come on after 30 minutes, this may indicate a defective battery pack and should be replaced.
- After normal usage, a minimum of 1 hour of charging time is required to fully recharge battery pack.
- The battery pack will become slightly warm to the touch while charging. This is normal and does not indicate a problem.
- Do not place the charger and battery pack in an area of extreme heat or cold. They will work best at normal room temperature.

NOTE: The charger and battery pack should be placed in a location where the temperature is more than 50°F but less than 100°F.

- When batteries become fully charged, unplug the charger from power supply and remove the battery pack.

CAUTION

Do not use any DC to AC power inverters. Charger will be **Damaged!**

OPERATION

CHARGING A HOT BATTERY PACK

When using the tool continuously, the batteries in the battery pack will become hot. You should let a hot battery pack cool down for approximately 30 minutes before attempting to recharge. When the battery pack becomes discharged and is hot, this will cause the green LED to come on instead of the red LED. After 30 minutes, reinsert the battery pack in the charger. If the green LED continues to remain on, return battery pack to your nearest Sears Repair Center for checking or replacing.

NOTE: This situation only occurs when continuous use of the tool causes the batteries to become hot. It does not occur under normal circumstances. Refer to **“CHARGING A COOL BATTERY PACK”** for normal recharging of batteries. If the charger does not charge your battery pack under normal circumstances, return both the battery pack and charger to your nearest Sears Repair Center for electrical check.

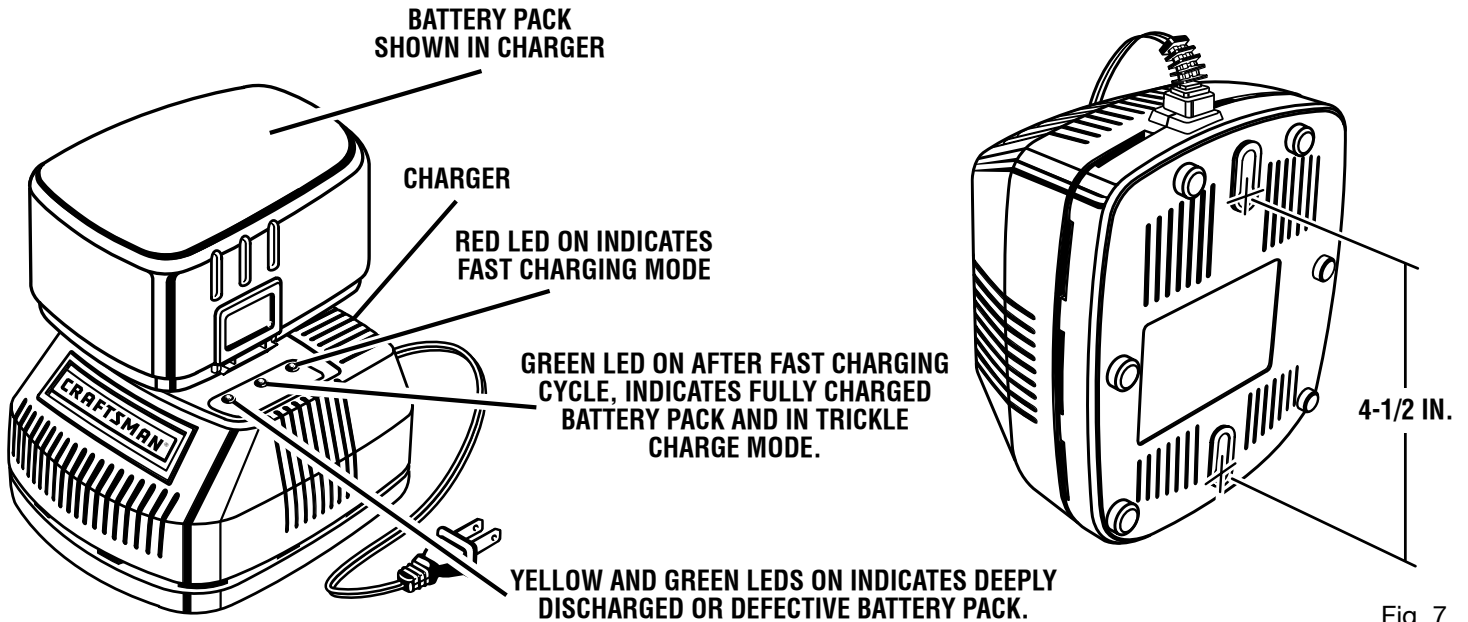

Fig. 7

OPERATION

KICKBACK

See Figures 8 - 11.

Kickback occurs when the blade stalls rapidly and the saw is driven back towards you. Blade stalling is caused by any action which pinches the blade in the wood.

⚠ DANGER: Release switch immediately if blade binds or saw stalls. Kickback could cause you to lose control of the saw. Loss of control can lead to serious injury.

To guard against kickback, avoid dangerous practices such as the following.

- Setting blade depth incorrectly.
- Sawing into knots or nails in workpiece.
- Twisting the blade while making a cut.
- Making a cut with a dull, gummed up, or improperly set blade.
- Supporting the workpiece incorrectly.
- Forcing a cut.
- Cutting warped or wet lumber.
- Operating the tool incorrectly or misusing the tool.

To lessen the chance of kickback, follow these safety practices.

- Keep the blade at the correct depth setting. The depth setting should not exceed 1/4 in. (6.35 mm) below the material being cut.
- Inspect the workpiece for knots or nails before cutting. Never saw into a knot or nail.
- Make straight cuts. Always use a straight edge guide when rip cutting. This helps prevent twisting the blade.
- Use clean, sharp, and properly set blades. Never make cuts with dull blades.
- Support the workpiece properly before beginning a cut.
- Use steady, even pressure when making a cut. Never force a cut.
- Do not cut warped or wet lumber.
- Hold the saw firmly with both hands and keep your body in a balanced position so as to resist the forces if kickback should occur.

⚠ WARNING: When using the saw, always stay alert and exercise control. Do not remove the saw from the workpiece while the blade is moving.

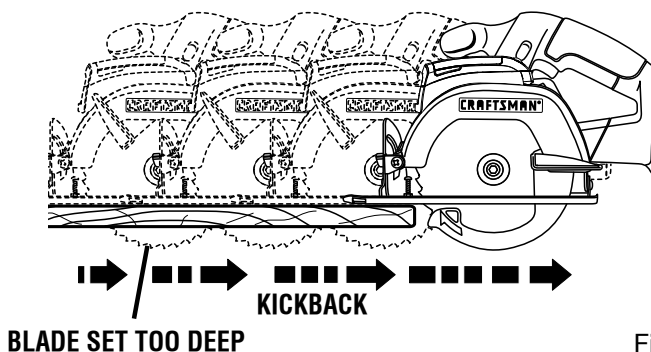
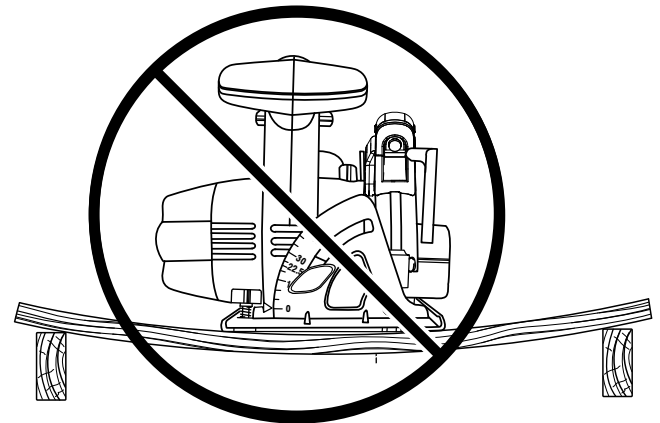
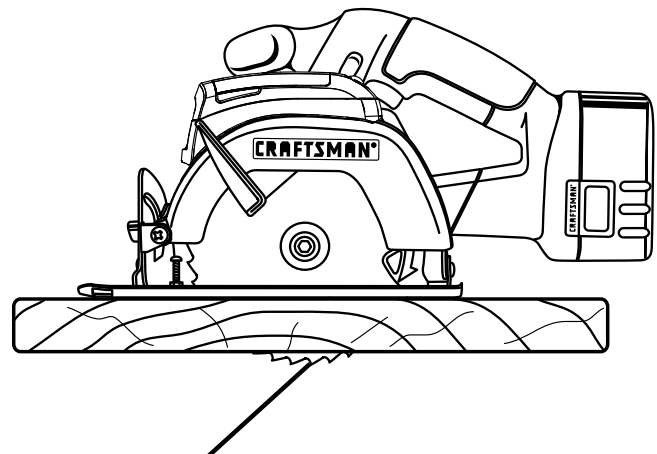

Fig. 8



INCORRECT SUPPORT

Fig. 9



**CORRECT BLADE DEPTH SETTING =
BLADE EXPOSED ONE BLADE TOOTH
BELOW THE MATERIAL TO BE CUT**

Fig. 10

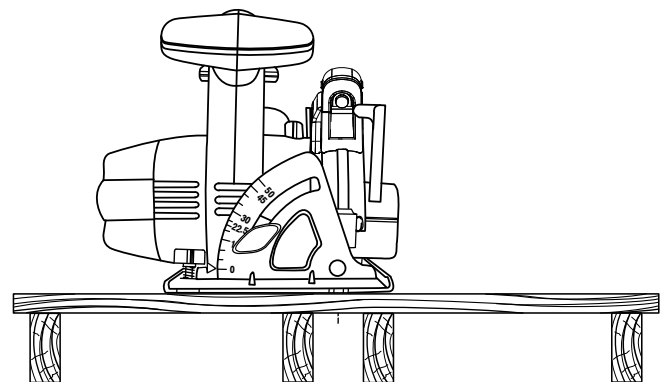

CORRECT SUPPORT

Fig. 11

OPERATION

SAW BLADES

The best of saw blades will not cut efficiently if they are not kept clean, sharp, and properly set. Using a dull blade will place a heavy load on the saw and increase the danger of kickback. Keep extra blades on hand, so that sharp blades are always available.

Gum and wood pitch hardened on blades will slow the saw down. Remove saw blade from the saw and use gum and pitch remover, hot water, or kerosene to remove these accumulations. **DO NOT USE GASOLINE.**

BLADE GUARD SYSTEM

See Figure 12.

The lower blade guard attached to your trim saw is there for your protection and safety. Do not alter it for any reason. If it becomes damaged, do not operate the saw until you have the guard repaired or replaced. Always leave guard in operating position when using the saw.

⚠ DANGER: When sawing through work, lower blade guard does not cover blade on the underside of work. Since blade is exposed on underside of work, keep hands and fingers away from cutting area. Any part of your body coming in contact with moving blade will result in serious injury.

⚠ CAUTION: Never use saw when guard is not operating correctly. Check the guard for correct operation before each use. The guard is operating correctly when it moves freely and readily returns to the closed position. If you drop the saw, check the lower blade guard and bumper for damage at all depth settings before reuse.

LOWER BLADE GUARD IS IN UP POSITION WHEN MAKING A CUT

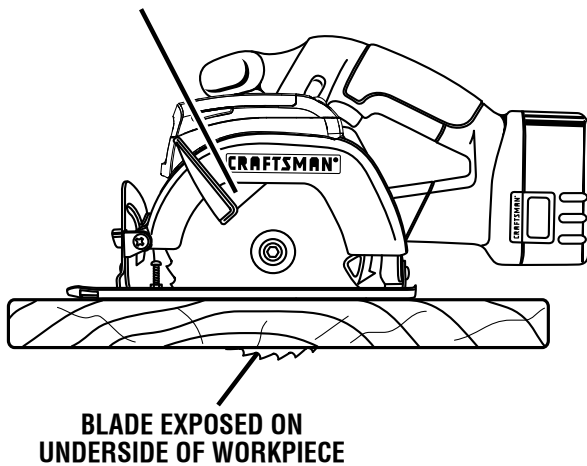

Fig. 12

STARTING/STOPPING THE SAW

See Figure 13.

To start the saw: Depress the switch trigger.

Always let the blade reach full speed, then guide the saw into the workpiece.

⚠ WARNING: The blade coming in contact with the workpiece before it reaches full speed could cause the saw to "kickback" towards you resulting in serious injury.

To stop the saw: Release the switch trigger.

After you release the switch trigger, allow the blade to come to a complete stop. **Do not remove the saw from the workpiece while the blade is moving.**

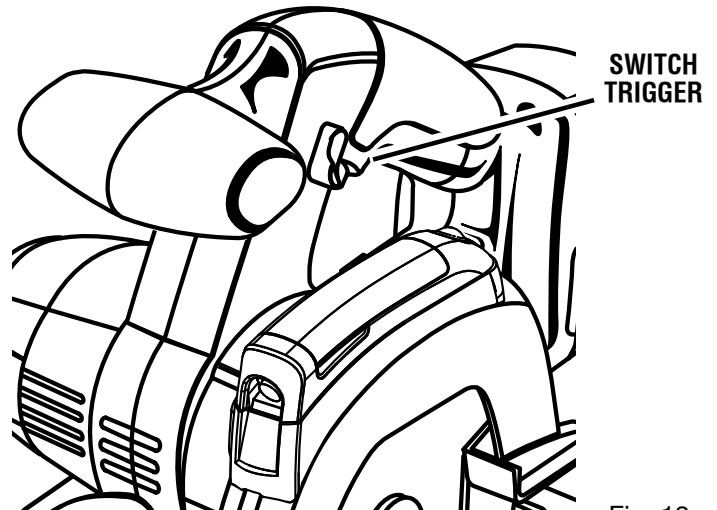

Fig. 13

OPERATION

ADJUSTING BLADE DEPTH

See Figure 14.

Always keep correct blade depth setting. The correct blade depth setting for all cuts should not exceed 1/4 in. (6.35 mm) below the material being cut. More blade depth will increase the chance of kickback and cause the cut to be rough. For more depth of cut accuracy, a scale is located on the upper blade guard.

Follow these directions to adjust the blade depth.

- Remove battery pack from saw.

⚠ WARNING: Failure to remove battery pack from the tool could result in accidental starting causing serious injury.

- Loosen depth adjustment knob.
- Determine the desired depth of cut.
- Locate depth of cut scale on back of upper blade guard.
- Hold base flat against the workpiece and raise or lower saw until the indicator mark on bracket aligns with notch on blade guard.
- Tighten depth adjustment knob securely.

USING THE LASER GUIDE

See Figure 15

⚠ WARNING: Do not stare into the laser beam or turn the laser on when the tool is not in use. Failure to do so could result in possible serious personal injury. The laser unit comes from the factory already installed and aligned. If the laser becomes misaligned after time refer to the "adjustments" section.

NOTE: Make a trial cut on a piece of scrap to ensure laser is aligned, adjusting the laser may be necessary.

- Mark the line to be cut on the workpiece.
- Adjust the depth and angle of the cut as needed.
- Switch on the laser beam.
- Install battery pack into the tool and start the motor.

NOTE: Do not touch the blade to the workpiece until the saw has reached maximum speed.

- Slowly push the saw forward into the workpiece.

NOTE: Keep the laser beam on the marked line on the workpiece for precision cutting.

- Once the cut is complete, allow the saw to come to a complete stop before turning off the laser.
- Remove battery pack from saw.

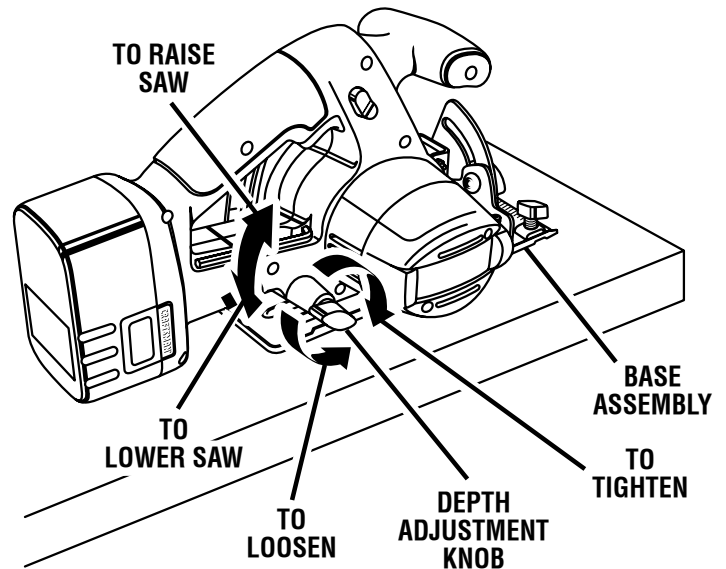

Fig. 14

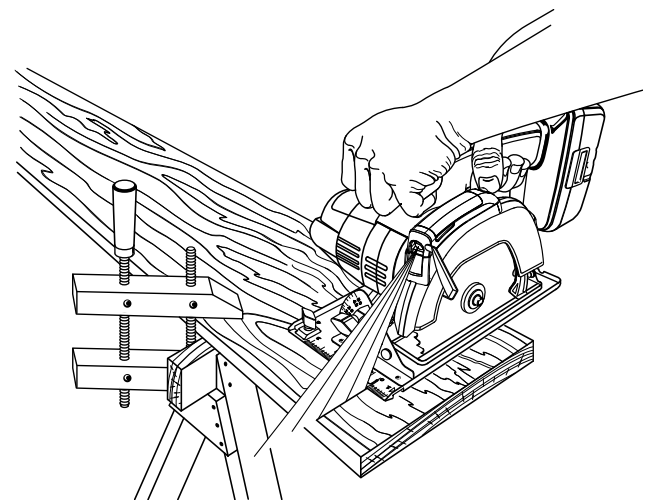
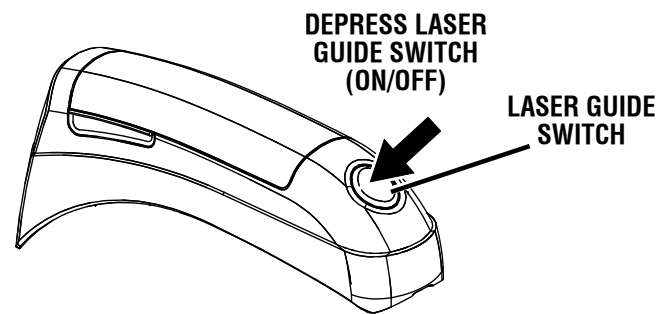

Fig. 15

OPERATION

OPERATING THE SAW

See Figures 16 - 18.

It is important to understand the correct method for operating the saw. Refer to the figures in this section to learn the correct and incorrect ways for handling the saw.

WARNING: To make sawing easier and safer, always maintain proper control of the saw. Loss of control could cause an accident resulting in possible serious injury.

DANGER: When lifting the saw from the workpiece, the blade is exposed on the underside of the saw until the lower blade guard closes. Make sure the lower blade guard is closed before setting the saw down.

To make the best possible cut, follow these helpful hints.

- Hold the saw firmly with both hands.
- Avoid placing your hand on the workpiece while making a cut.
- Support the workpiece so that the cut (kerf) is always to your side.
- Support the workpiece near the cut.
- Clamp the workpiece securely so that the workpiece will not move during the cut.
- Always place the saw on the workpiece that is supported, not the “cut off” piece.
- Place the workpiece with the “good” side down.
- Draw a guideline along the desired line of cut before beginning your cut.

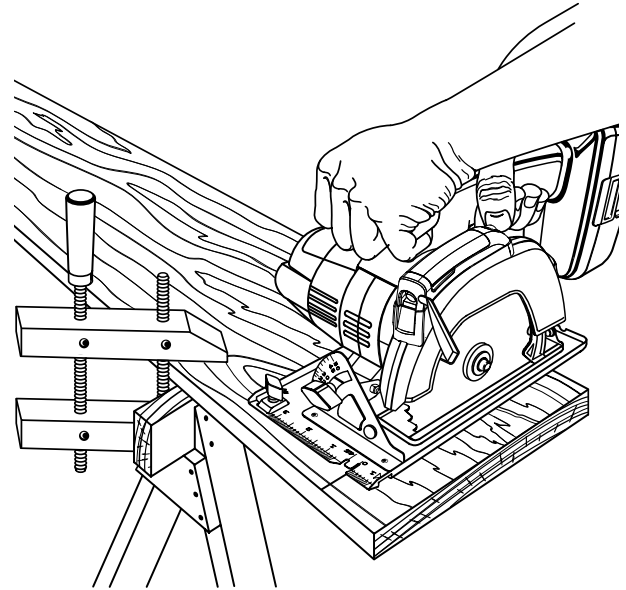

CORRECT

Fig. 17

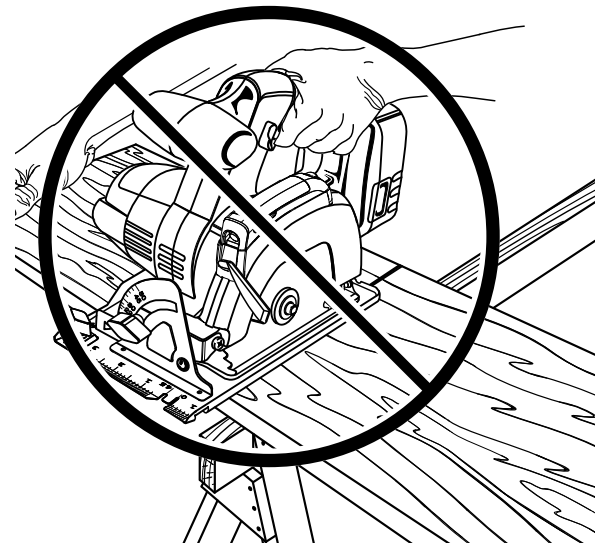

WRONG

Fig. 18

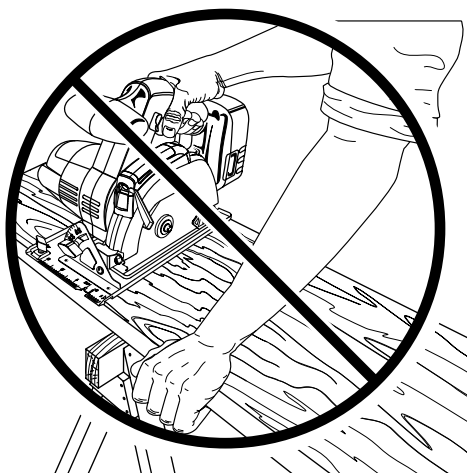

WRONG

Fig. 16

OPERATION

CROSS CUTTING/RIP CUTTING

See Figure 19.

When making a cross cut or rip cut, align the line of cut with the outer blade guide notch on the base as shown in the figure.

Since blade thicknesses vary, always make a trial cut in scrap material along a guideline to determine how much, if any, you must offset the guideline to produce an accurate cut.

NOTE: The distance from the line of cut to the guideline is the amount you should offset the guide.

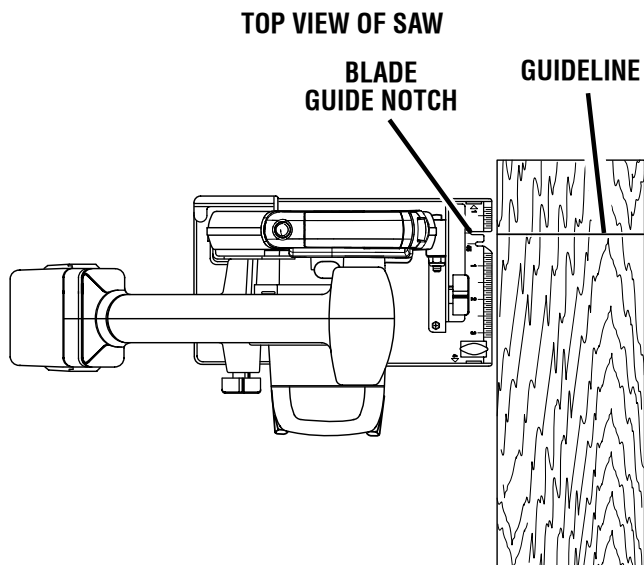

ALIGN OUTER BLADE GUIDE NOTCH ON SAW BASE WITH LINE OF CUT AS SHOWN WHEN MAKING CROSS CUTS OR RIP CUTS

Fig. 19

TO RIP CUT WITHOUT EDGE GUIDE

See Figure 20.

Use a guide when making long or wide rip cuts with the saw.

Follow these directions to rip cut:

- Secure the workpiece.
- Clamp a straight edge to the workpiece using C-clamps.
- Saw along the straight edge to achieve a straight rip cut.

NOTE: Do not bind the blade in the cut.

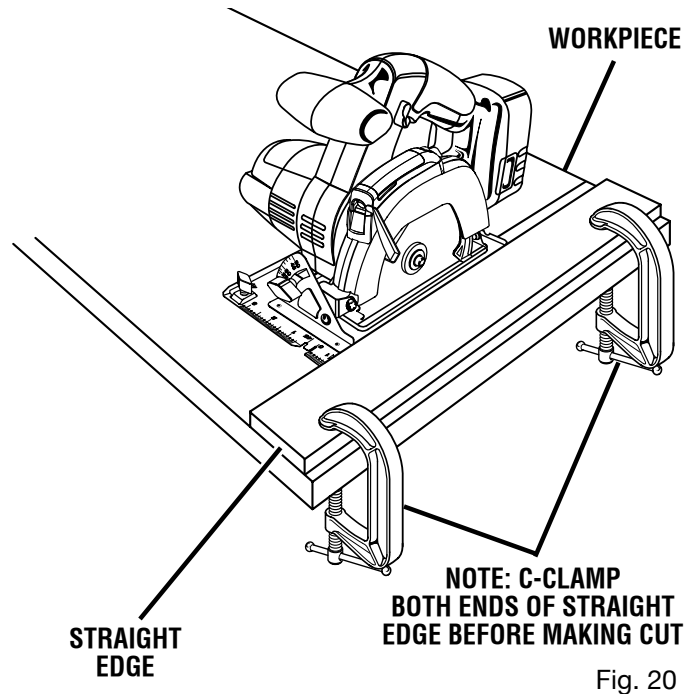

TO RIP CUT WITH EDGE GUIDE

See Figure 21.

Follow these directions to use the edge guide:

- Secure the workpiece.
- Position the face of the edge guide firmly against the edge of workpiece.
- Guide the saw along the edge to achieve a straight rip cut.

NOTE: The guiding edge of the workpiece must be straight for your cut to be straight. Use caution to prevent the blade from binding in the cut.

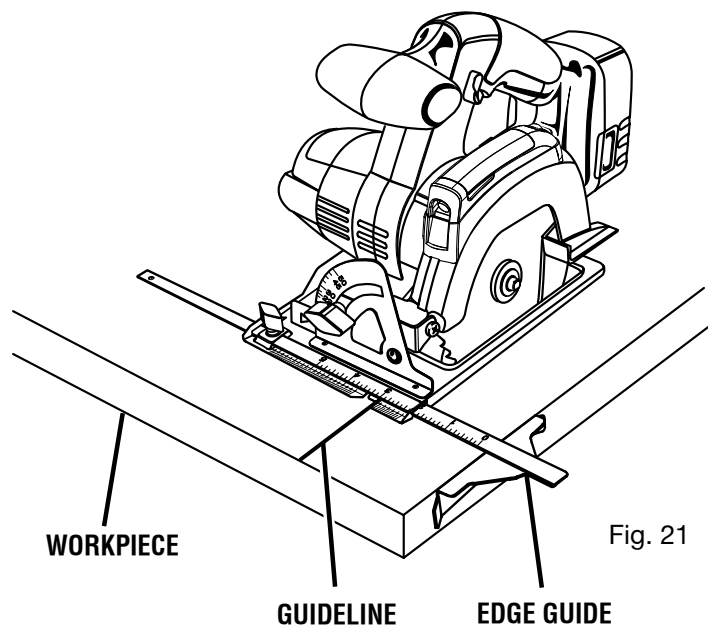

OPERATION

BEVEL CUTTING

See Figures 22 - 24.

To make the best possible cut, follow these helpful hints:

- Align the line of cut with the inner blade guide notch on the base when making 45° bevel cuts.
- Make a trial cut in scrap material along a guideline to determine how much you should offset the guideline on the cutting material.
- Adjust the angle of the cut to any desired setting between zero and 51.5°. Refer to "To Adjust Bevel Setting" next.

NOTE: When making bevel cuts, you may need to re-adjust laser (See "Adjusting the Laser.")

TO ADJUST BEVEL SETTING

See Figure 23

Follow these directions to adjust the bevel setting:

- Remove battery pack from your trim saw.

⚠ WARNING: Failure to remove battery pack from the tool could result in accidental starting causing serious injury.

- Loosen bevel adjustment knob.
- Raise motor housing end of saw until you reach desired angle setting on bevel scale.
- Tighten bevel adjustment knob securely.

⚠ WARNING: Attempting a bevel cut without having the bevel adjustment knob securely tightened can result in serious injury.

TO BEVEL CUT

See Figure 24.

Follow these directions to bevel cut:

- Hold the saw firmly with both hands as shown.
- Rest the front edge of the base on the workpiece.
- Start the saw and let the blade reach full speed.
- Guide the saw into the workpiece and make the cut.
- Release the trigger and allow the blade to come to a complete stop.
- Lift the saw from the workpiece.

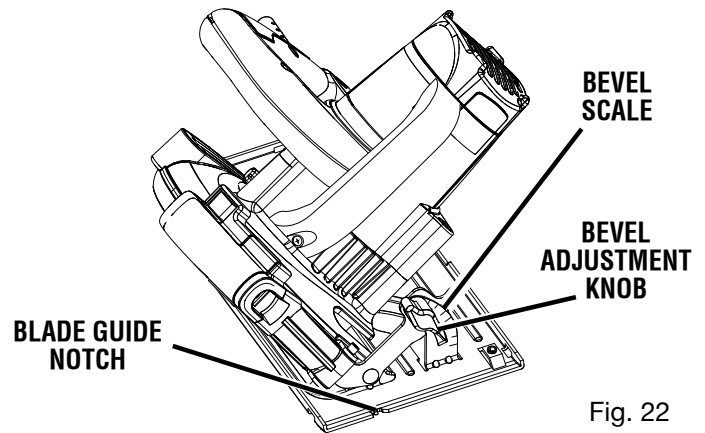
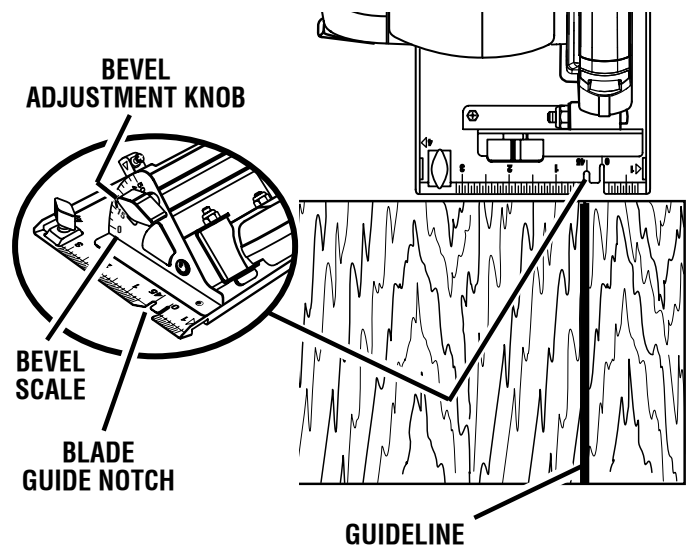

Fig. 22



ALIGN INNER BLADE GUIDE NOTCH ON SAW BASE WITH LINE OF CUT AS SHOWN WHEN MAKING 45° BEVEL CUTS

Fig. 23

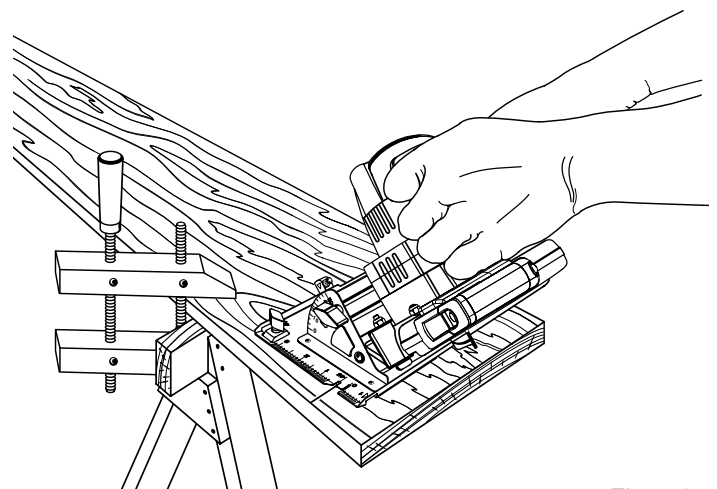

Fig. 24

OPERATION

POSITIVE 0° BEVEL STOP

See Figure 25.

The saw has a positive 0° bevel stop that has been factory adjusted to assure 0° angle of the saw blade when making 90° cuts.

TO CHECK POSITIVE 0° BEVEL STOP

Follow these directions to check the positive 0° bevel stop:

- Remove battery pack from your trim saw.

WARNING: Failure to remove battery pack from the tool could result in accidental starting causing serious injury.

- Place the saw in an upside down position on a workbench.
- Check the squareness of the saw blade to the base of the saw using a carpenter's square.

TO ADJUST POSITIVE 0° BEVEL STOP

Follow these directions to adjust the positive 0° bevel stop:

- Remove battery pack from your trim saw.

WARNING: Failure to remove battery pack from the tool could result in accidental starting causing serious injury.

- Loosen bevel adjustment knob.
- Turn setscrew with hex key and adjust base until it is square with the saw blade.
- Tighten bevel adjustment knob securely.

WARNING: Attempting a bevel cut without having the bevel adjustment knob securely tightened can result in serious injury.

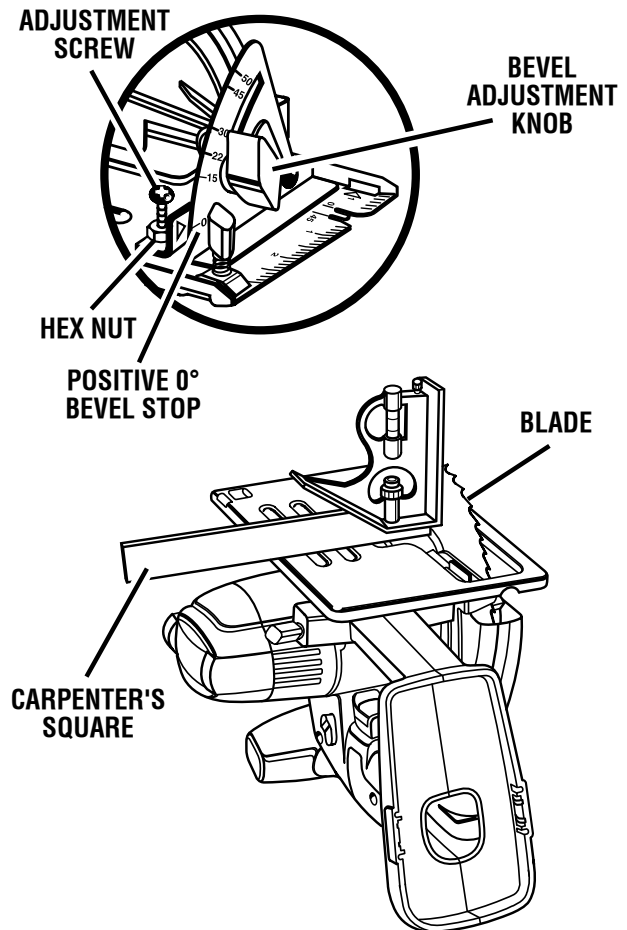

Fig. 25

OPERATION

POCKET CUTTING

See Figure 26.

WARNING: Always adjust bevel setting to zero before making a pocket cut. Attempting a pocket cut at any other setting can result in loss of control of the saw possibly causing serious injury.

Follow these directions to pocket cut:

- Adjust the bevel setting to zero.
- Set the blade to the correct blade depth setting.
- Swing the lower blade guard up using the lower blade guard handle.

NOTE: Always raise the lower blade guard with the handle to avoid serious injury.

- Hold the lower blade guard by the handle.
- Rest the front of the base flat against the workpiece with the rear of the handle raised so the blade does not touch the workpiece.
- Start the saw and let the blade reach full speed.
- Guide the saw into the workpiece and make the cut.

WARNING: Always cut in a forward direction when pocket cutting. Cutting in the reverse direction could cause the saw to climb up on the workpiece and back toward you.

- Release the trigger and allow the blade to come to a complete stop.
- Lift the saw from the workpiece.
- Clear corners out with a hand saw or sabre saw.

WARNING: Never tie the lower blade guard in a raised position. Leaving the blade exposed could lead to serious injury.

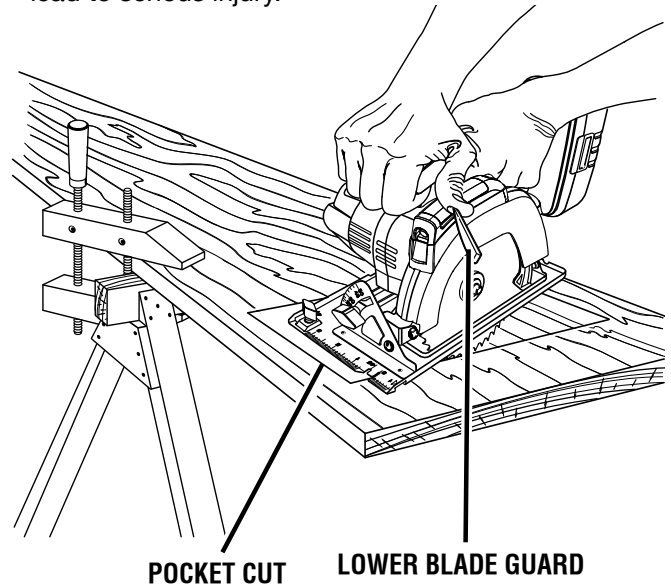

Fig. 26

ADJUSTMENTS

WARNING: Before performing any adjustment, make sure the battery pack is removed from tool. Failure to heed this warning could result in serious personal injury.

ADJUSTING THE LASER

See Figure 27.

NOTE: Draw a pencil line on a scrap workpiece parallel to the long edge of the base as a straight line guide to aid in the adjusting process.

- Remove battery pack from your trim saw.
- Make sure laser is turned off.
- Remove the laser cover by lifting it off its base.
- Turn laser on.
- Loosen the screw inside laser.
- Rest the front of the base on scrap workpiece.
- Adjust the laser beam with the mark on the scrap workpiece by loosening the screw to the laser aperture and slowly moving laser guide left or right.
- Since blade thicknesses vary, always make a trial cut in scrap workpiece to ensure an accurate cut.
- Once alignment is achieved tighten the screw.
- Replace the laser cover.
- Check for proper alignment.
- Repeat as necessary until laser is aligned.

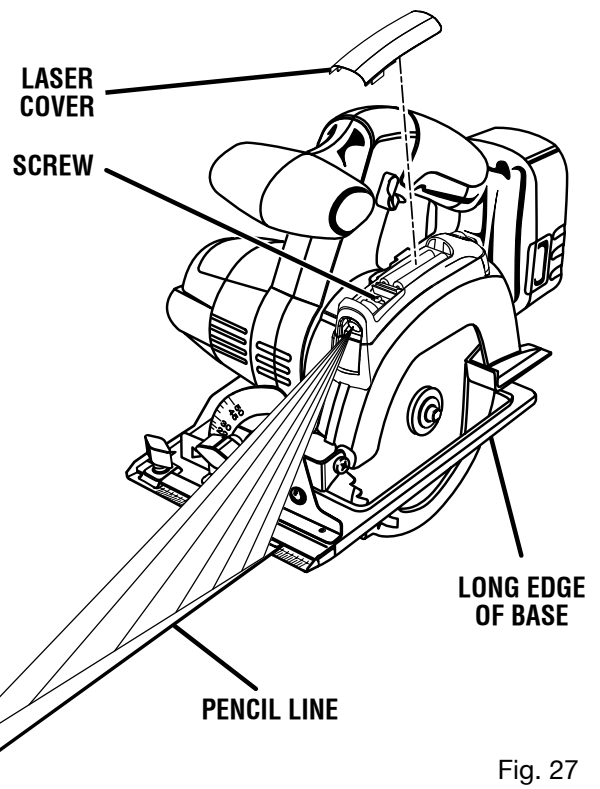

Fig. 27

MAINTENANCE

WARNING: When servicing use only identical Craftsman replacement parts. Use of any other parts may create a hazard or cause product damage.

WARNING: Always wear safety goggles or safety glasses with side shields during power tool operation or when blowing dust. If operation is dusty, also wear a dust mask.

GENERAL MAINTENANCE

Avoid using solvents when cleaning plastic parts. Most plastics are susceptible to damage from various types of commercial solvents and may be damaged by their use. Use clean cloths to remove dirt, dust, oil, grease, etc.

WARNING: Do not at any time let brake fluids, gasoline, petroleum-based products, penetrating oils, etc., come in contact with plastic parts. Chemicals can damage, weaken or destroy plastic which may result in serious personal injury.

Electric tools used on fiberglass material, wallboard, spackling compounds, or plaster are subject to accelerated wear and possible premature failure because the fiberglass chips and grindings are highly abrasive to bearings, brushes, commutators, etc. Consequently, we do not recommended using this tool for extended work on these types of materials. However, if you do work with any of these materials, it is extremely important to clean the tool using compressed air.

LUBRICATION

All of the bearings in this tool are lubricated with a sufficient amount of high grade lubricant for the life of the unit under normal operating conditions. Therefore, no further lubrication is required.

REPLACING LASER GUIDE BATTERIES

See Figure 28.

- Remove battery pack from saw.
- Make sure laser is turned off.
- Remove the laser cover by lifting it off its base.
- Remove both AAA batteries.
- Install the two AAA batteries aligning the positives (+) with positives (+) and the negatives (-) with negatives (-) as shown on the inside base of laser.
- Replace the laser cover.
- Turn on laser.

CAUTION: Use of controls or adjustments or performance other than those specified herein may result in hazardous radiation exposure.

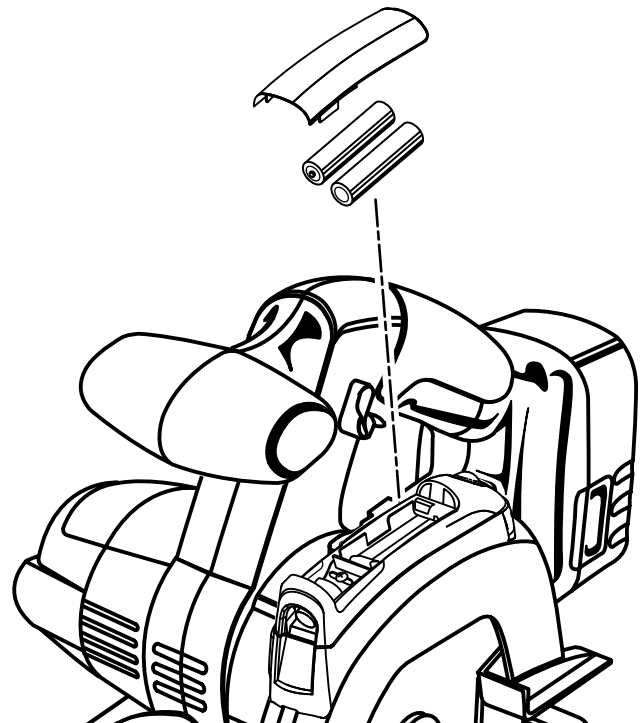
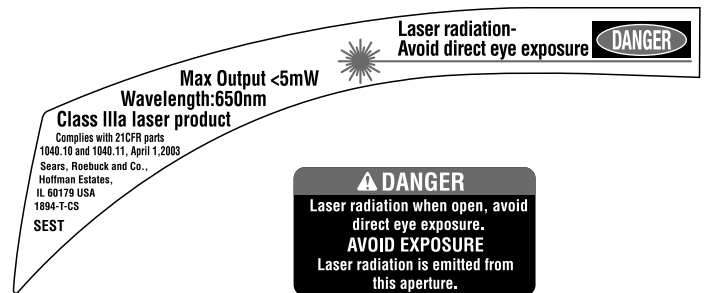

Fig. 28

MAINTENANCE

BATTERIES

The battery pack for this tool is equipped with nickel-cadmium rechargeable batteries. Length of service from each charging will depend on the type of work you are doing.

The batteries in this tool have been designed to provide maximum trouble-free life. However, like all batteries, they will eventually wear out. **Do not** disassemble battery pack and attempt to replace the batteries. Handling of these batteries, especially when wearing rings and jewelry, could result in a serious burn.

To obtain the longest possible battery life, we suggest the following:

- Remove the battery pack from the charger once it is fully charged and ready for use.

For battery pack storage longer than 30 days:

- Store the battery pack where the temperature is below 80°F.
- Store battery packs in a "discharged" condition.

BATTERY PACK REMOVAL AND PREPARATION FOR RECYCLING



To preserve natural resources, please recycle or dispose of batteries properly.

This product contains nickel-cadmium batteries. Local, state or federal laws may prohibit disposal of nickel-cadmium batteries in ordinary trash.

Consult your local waste authority for information regarding available recycling and/or disposal options.

⚠ WARNING: Upon removal, cover the battery pack's terminals with heavy duty adhesive tape. Do not attempt to destroy or disassemble battery pack or remove any of its components. Nickel-cadmium batteries must be recycled or disposed of properly. Also, never touch both terminals with metal objects and/or body parts as short circuit may result. Keep away from children. Failure to comply with these warnings could result in fire and/or serious injury.

ACCESSORIES

The following recommended accessories are currently available at Sears retail stores:

- 5-1/2 in. Thin Kerf Blade

⚠ WARNING: Current attachments and accessories available for use with this tool are listed above. Do not use any attachments or accessories not recommended by the manufacturer of this tool. The use of attachments or accessories not recommended can result in serious personal injury.

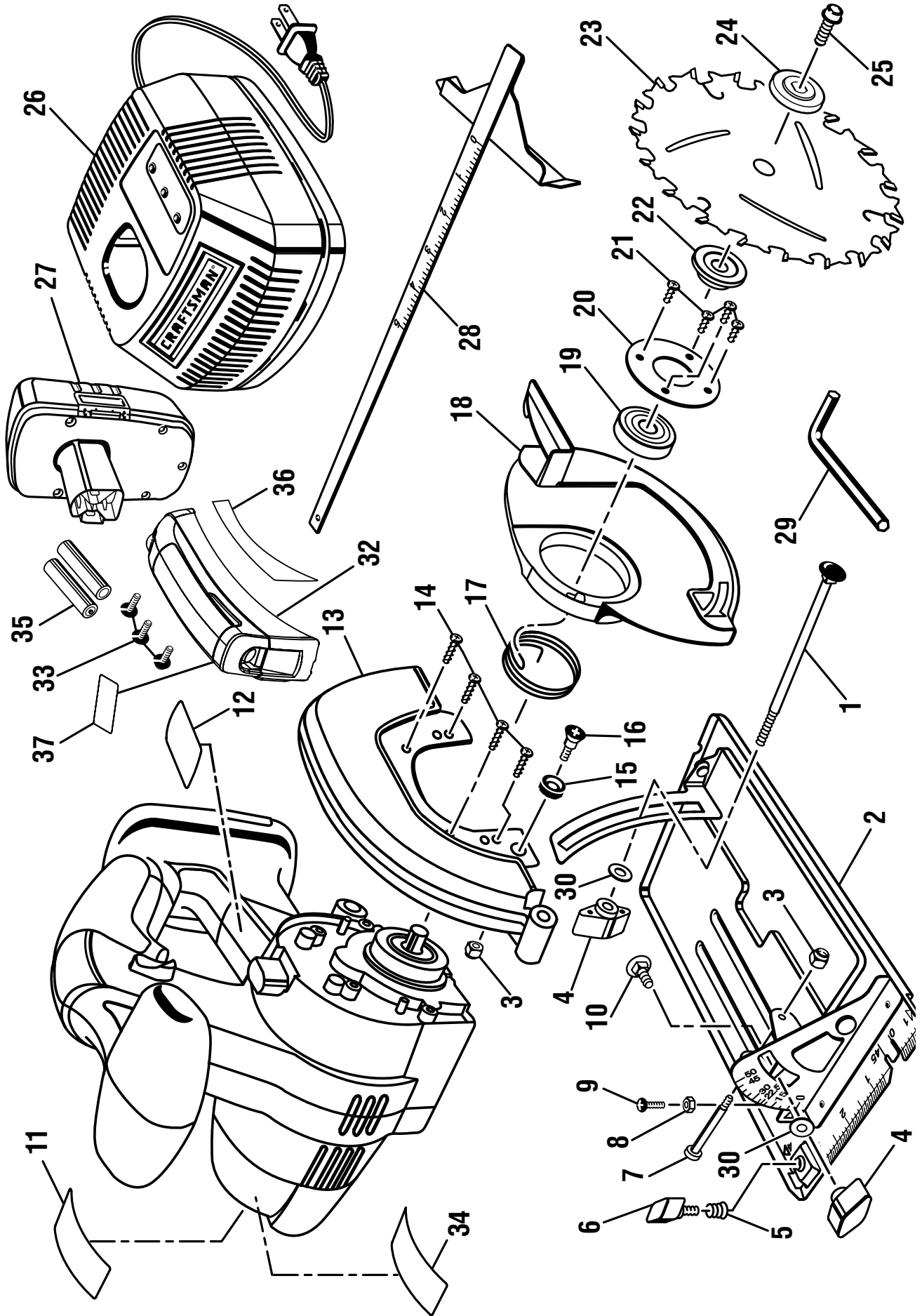

CRAFTSMAN 19.2 VOLT CORDLESS TRIM SAW – MODEL NUMBER 315.115160

The model number will be found on a plate attached to the motor housing. Always mention the model number in all correspondence regarding your **CORDLESS TRIM SAW** or when ordering repair parts.

SEE BACK PAGE FOR PARTS ORDERING INSTRUCTIONS

PARTS LIST

KEY NO.	PART NUMBER	DESCRIPTION	QTY.	KEY NO.	PART NUMBER	DESCRIPTION	QTY.
1	660143001	* Carriage bolt (M6 X 100 mm).....	1	20	6850303	Bearing Retainer.....	1
2	3025516	Base Assembly.....	1	21	6620104	* Screw (M2.6 X 10 mm Pan Hd.).....	4
3	670974001	* Lock Nut (M5).....	2	22	6112004	Inner Blade Washer.....	1
4	5224502	Knob.....	2	23	***	Saw Blade.....	1
5	680001001	Spring.....	1	24	610121001	Outer Blade Washer.....	1
6	520177002	Wing Screw.....	1	25	975532-000	Blade Screw.....	1
7	660145001	* Screw (M6 X 16 mm Hex Hd.).....	1	26	1425301	Charger (**item No. 911041).....	1
8	680022001	Hex Nut.....	1	27	1323517 or 1323903	Battery Pack (**item No. 911375).....	1
9	660212004	* Screw (M4 X 16 mm Pan Hd.).....	1	28	670957001	Edge guide.....	1
10	660142001	* Carriage Bolt (M6 X 12 mm).....	1	29	680002001	Blade Wrench (6 mm Hex Key).....	1
11	9427205	Logo Plate.....	1	30	5228001	Washer.....	2
12	940298017	Warning Label.....	1	31	300912141	Carrying Case - Not Shown.....	1
13	640556011	Upper Blade Guard.....	1	32	301014004	Laser Guide Assembly.....	1
14	6620803	* Screw (M4 X 22 mm Pan Hd.).....	4	33	660212031	* Screw (M3 X 8 mm Washer Hd).....	3
15	5217802	Bumper.....	1	34	940271022	Data Plate.....	1
16	6619302	* Screw (M5 X 15.5 mm).....	1	35	750273001	* Battery.....	2
17	6867201	Torsion Spring.....	1	36	940214085	Laser Data Plate.....	1
18	550994005	Lower Blade Guard.....	1	37	940230081	Laser Warning.....	1
19	6807001	Ball Bearing (Ntn #6000zz).....	1		983000-522	Operator's Manual	

* Standard Hardware Item – May Be Purchased Locally
 ** Can Be Purchased Thru RSOS (Retail Special Order System)
 *** Complete Assortment Available At Your Nearest Sears Retail Store

Operator's Manual

CRAFTSMAN®

19.2 Volt Reciprocating Saw Variable Speed

Model No.
315.114270

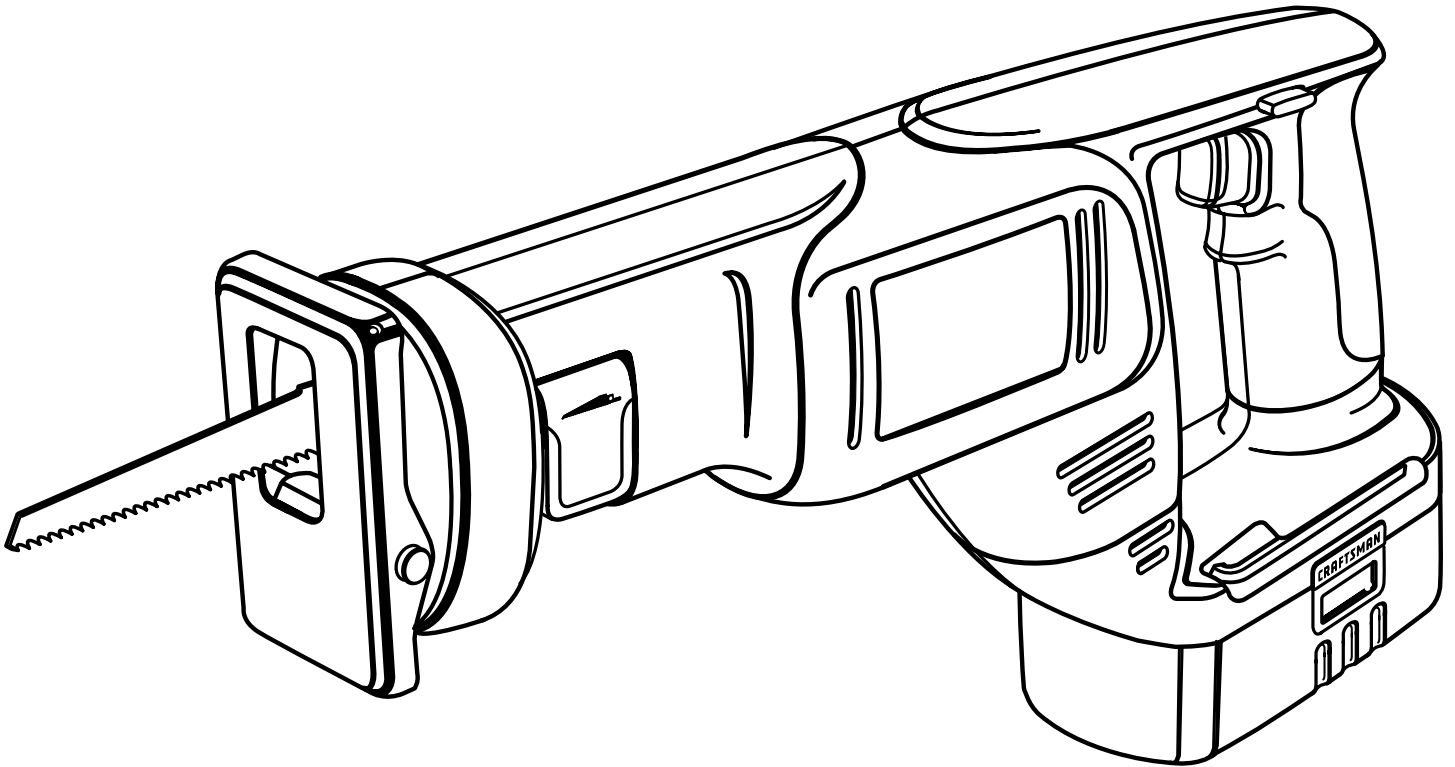

⚠ WARNING: To reduce the risk of injury, the user must read and understand the operator's manual before using this product.

Customer Help Line: 1-800-932-3188

Sears, Roebuck and Co., 3333 Beverly Rd., Hoffman Estates, IL 60179 USA
Visit the Craftsman web page: www.sears.com/craftsman

983000-193
3-04

Save this manual for future reference



TABLE OF CONTENTS

■ Warranty.....	2
■ Introduction.....	2
■ General Safety Rules	3-4
■ Specific Safety Rules.....	4
■ Safety Rules for Charger.....	5
■ Symbols	6-7
■ Features	8-9
■ Assembly	10
■ Operation	10-14
■ Maintenance	15
■ Accessories	16
■ Exploded View and Parts List.....	17
■ Parts Ordering / Service	18

WARRANTY

ONE YEAR FULL WARRANTY ON CRAFTSMAN TOOL

If this Craftsman tool fails to give complete satisfaction within one year from date of purchase, **RETURN IT TO THE NEAREST SEARS STORE OR SEARS PARTS & REPAIR CENTER IN THE UNITED STATES**, and Sears will repair it, free of charge.

If this Craftsman tool is used for commercial or rental purposes, this warranty applies for only 90 days from the date of purchase.

This warranty gives you specific legal rights, and you may also have other rights which vary from state to state.

Sears, Roebuck and Co., Dept. 817WA, Hoffman Estates, IL 60179

INTRODUCTION

This tool has many features for making its use more pleasant and enjoyable. Safety, performance, and dependability have been given top priority in the design of this product making it easy to maintain and operate.

GENERAL SAFETY RULES

⚠ WARNING! READ AND UNDERSTAND ALL INSTRUCTIONS. Failure to follow all instructions listed below, may result in electric shock, fire and/or serious personal injury.

SAVE THESE INSTRUCTIONS

WORK AREA

- **Keep your work area clean and well lit.** Cluttered benches and dark areas invite accidents.
- **Do not operate power tools in explosive atmospheres, such as in the presence of flammable liquids, gases, or dust.** Power tools create sparks which may ignite the dust or fumes.
- **Keep bystanders, children, and visitors away while operating a power tool.** Distractions can cause you to lose control.

ELECTRICAL SAFETY

- **A battery operated tool with integral batteries or a separate battery pack must be recharged only with the specified charger for the battery.** A charger that may be suitable for one type of battery may create a risk of fire when used with another battery.
- **Use battery operated tool only with specifically designated battery pack.** Use of any other batteries may create a risk of fire.
- **Use battery only with charger listed.**

MODEL	BATTERY PACK	CHARGER
315.114270	Item No. <u>9</u> 11375 (1323517 or 1323903)	Item No. <u>9</u> 11041 (1425301)

- **Do not abuse the cord. Never use the cord to carry the charger. Keep cord away from heat, oil, sharp edges, or moving parts. Replace damaged cords immediately.** Damaged cords may create a fire.

PERSONAL SAFETY

- **Stay alert, watch what you are doing and use common sense when operating a power tool. Do not use tool while tired or under the influence of drugs, alcohol, or medication.** A moment of inattention while operating power tools may result in serious personal injury.
- **Dress properly. Do not wear loose clothing or jewelry. Contain long hair. Keep your hair, clothing, and gloves away from moving parts.** Loose clothes, jewelry, or long hair can be caught in moving parts.
- **Avoid accidental starting. Be sure switch is in the locked or off position before inserting battery pack.** Carrying tools with your finger on the switch or inserting the battery pack into a tool with the switch on invites accidents.
- **Remove adjusting keys or wrenches before turning the tool on.** A wrench or a key that is left attached to a rotating part of the tool may result in personal injury.

- **Do not overreach. Keep proper footing and balance at all times.** Proper footing and balance enable better control of the tool in unexpected situations.
- **Use safety equipment. Always wear eye protection.** Dust mask, non-skid safety shoes, hard hat, or hearing protection must be used for appropriate conditions.
- **Do not wear loose clothing or jewelry. Contain long hair.** Loose clothes, jewelry, or long hair can be drawn into air vents.
- **Do not use on a ladder or unstable support.** Stable footing on a solid surface enables better control of the tool in unexpected situations.

TOOL USE AND CARE

- **Use clamps or other practical way to secure and support the workpiece to a stable platform.** Holding the work by hand or against your body is unstable and may lead to loss of control.
- **Do not force tool. Use the correct tool for your application.** The correct tool will do the job better and safer at the rate for which it is designed.
- **Do not use tool if switch does not turn it on or off.** A tool that cannot be controlled with the switch is dangerous and must be repaired.
- **Disconnect battery pack from tool or place the switch in the locked or off position before making any adjustments, changing accessories, or storing the tool.** Such preventive safety measures reduce the risk of starting the tool accidentally.
- **Store idle tools out of reach of children and other untrained persons.** Tools are dangerous in the hands of untrained users.
- **When battery pack is not in use, keep it away from other metal objects like: paper clips, coins, keys, nails, screws, or other small metal objects that can make a connection from one terminal to another.** Shorting the battery terminals together may cause sparks, burns, or a fire.
- **Maintain tools with care. Keep cutting tools sharp and clean.** Properly maintained tools with sharp cutting edges are less likely to bind and are easier to control.
- **Check for misalignment or binding of moving parts, breakage of parts, and any other condition that may affect the tool's operation. If damaged, have the tool serviced before using.** Many accidents are caused by poorly maintained tools.
- **Use only accessories that are recommended by the manufacturer for your model.** Accessories that may be suitable for one tool may create a risk of injury when used on another tool.
- **Keep the tool and its handle dry, clean and free from oil and grease.** Always use a clean cloth when cleaning. Never use brake fluids, gasoline, petroleum-based products, or any strong solvents to clean your tool. Following this rule will reduce the risk of loss of control and deterioration of the enclosure plastic.

GENERAL SAFETY RULES

SERVICE

- **Tool service must be performed only by qualified repair personnel.** Service or maintenance performed by unqualified personnel may result in a risk of injury.
- **When servicing a tool, use only identical replacement parts. Follow instructions in the Maintenance section of this manual.** Use of unauthorized parts or failure to follow Maintenance Instructions may create a risk of shock or injury.

SPECIFIC SAFETY RULES

- **Hold tool by insulated gripping surfaces when performing an operation where the cutting tool may contact hidden wiring.** Contact with a “live” wire will also make exposed metal parts of the tool “live” and shock the operator.
- **Know your power tool. Read operator’s manual carefully. Learn its applications and limitations, as well as the specific potential hazards related to this tool.** Following this rule will reduce the risk of electric shock, fire, or serious injury.
- **Always wear safety glasses with side shields.** Everyday glasses have only impact resistant lenses. They are NOT safety glasses. Following this rule will reduce the risk of eye injury.
- **Battery tools do not have to be plugged into an electrical outlet; therefore, they are always in operating condition. Be aware of possible hazards when not using your battery tool or when changing accessories.** Following this rule will reduce the risk of electric shock, fire, or serious personal injury.
- **Do not place battery tools or their batteries near fire or heat.** This will reduce the risk of explosion and possibly injury.
- **Never use a battery that has been dropped or received a sharp blow.** A damaged battery is subject to explosion. Properly dispose of a dropped or damaged battery immediately.
- **Batteries vent hydrogen gas and can explode in the presence of a source of ignition, such as a pilot light.** To reduce the risk of serious personal injury, never use any cordless product in the presence of open flame. An exploded battery can propel debris and chemicals. If exposed, flush with water immediately.
- **Do not charge battery tool in a damp or wet location.** Following this rule will reduce the risk of electric shock.
- **For best results, your battery tool should be charged in a location where the temperature is more than 50°F but less than 100°F. Do not store outside or in vehicles.**
- **Under extreme usage or temperature conditions, battery leakage may occur. If liquid comes in contact with your skin, wash immediately with soap and water, then neutralize with lemon juice or vinegar. If liquid gets into your eyes, flush them with clean water for at least 10 minutes, then seek immediate medical attention.** Following this rule will reduce the risk of serious personal injury.

SAFETY RULES FOR CHARGER

⚠ WARNING! READ AND UNDERSTAND ALL INSTRUCTIONS. Failure to follow all instructions listed below, may result in electric shock, fire and/or serious personal injury.

■ **Before using battery charger**, read all instructions and cautionary markings in this manual, on battery charger, battery, and product using battery to prevent misuse of the products and possible injury or damage.

CAUTION: To reduce the risk of electric shock or damage to the charger and battery, charge only nickel-cadmium rechargeable batteries as specifically designated on your charger. Other types of batteries may burst, causing personal injury or damage.

■ **Do not use charger outdoors or expose to wet or damp conditions.** Water entering charger will increase the risk of electric shock.

■ **Use of an attachment not recommended or sold by the battery charger manufacturer may result in a risk of fire, electric shock, or injury to persons.** Following this rule will reduce the risk of electric shock, fire, or serious personal injury.

■ **Do not abuse cord or charger.** Never use the cord to carry the charger. Do not pull the charger cord rather than the plug when disconnecting from receptacle. Damage to the cord or charger could occur and create an electric shock hazard. Replace damaged cords immediately.

■ **Make sure cord is located so that it will not be stepped on, tripped over, come in contact with sharp edges or moving parts or otherwise subjected to damage or stress.** This will reduce the risk of accidental falls, which could cause injury, and damage to the cord, which could result in electric shock.

■ **Keep cord and charger from heat to prevent damage to housing or internal parts.**

■ **Do not let gasoline, oils, petroleum-based products, etc. come in contact with plastic parts.** They contain chemicals that can damage, weaken, or destroy plastic.

■ **An extension cord should not be used unless absolutely necessary.** Use of improper extension cord could result in a risk of fire and electric shock. If extension cord must be used, make sure:

- a. That pins on plug of extension cord are the same number, size and shape as those of plug on charger.
- b. That extension cord is properly wired and in good electrical condition; and
- c. That wire size is large enough for AC ampere rating of charger as specified below:

Cord Length (Feet)	25'	50'	100'
Cord Size (AWG)	16	16	16

NOTE: AWG = American Wire Gauge

- **Do not operate charger with a damaged cord or plug**, which could cause shorting and electric shock. If damaged, have the charger replaced by an authorized serviceman.
- **Do not operate charger if it has received a sharp blow, been dropped, or otherwise damaged in any way.** Take it to an authorized serviceman for electrical check to determine if the charger is in good working order.
- **Do not disassemble charger.** Take it to an authorized serviceman when service or repair is required. Incorrect reassembly may result in a risk of electric shock or fire.
- **Unplug charger from outlet before attempting any maintenance or cleaning to reduce the risk of electric shock.**
- **Disconnect charger from the power supply when not in use.** This will reduce the risk of electric shock or damage to the charger if metal items should fall into the opening. It also will help prevent damage to the charger during a power surge.
- **Risk of electric shock.** Do not touch uninsulated portion of output connector or uninsulated battery terminal.
- **Save these instructions.** Refer to them frequently and use them to instruct others who may use this tool. If you loan someone this tool, loan them these instructions also to prevent misuse of the product and possible injury.











⚠ WARNING: Some dust created by power sanding, sawing, grinding, drilling, and other construction activities contains chemicals known to cause cancer, birth defects or other reproductive harm. Some examples of these chemicals are:

- lead from lead-based paints,
- crystalline silica from bricks and cement and other masonry products, and
- arsenic and chromium from chemically-treated lumber.

Your risk from these exposures varies, depending on how often you do this type of work. To reduce your exposure to these chemicals: work in a well ventilated area, and work with approved safety equipment, such as those dust masks that are specially designed to filter out microscopic particles.



SYMBOLS

Some of the following symbols may be used on this tool. Please study them and learn their meaning. Proper interpretation of these symbols will allow you to operate the tool better and safer.

SYMBOL	NAME	DESIGNATION/EXPLANATION
V	Volts	Voltage
A	Amperes	Current
Hz	Hertz	Frequency (cycles per second)
W	Watt	Power
min	Minutes	Time
~	Alternating Current	Type of current
==	Direct Current	Type or a characteristic of current
n ₀	No Load Speed	Rotational speed, at no load
	Class II Construction	Double-insulated construction
.../min	Per Minute	Revolutions, strokes, surface speed, orbits etc., per minute
	Wet Conditions Alert	Do not expose to rain or use in damp locations.
	Read The Operator's Manual	To reduce the risk of injury, user must read and understand operator's manual before using this product.
	Eye Protection	Always wear safety goggles or safety glasses with side shields and a full face shield when operating this product.
	Safety Alert	Precautions that involve your safety.
	No Hands Symbol	Failure to keep your hands away from the blade will result in serious personal injury.
	No Hands Symbol	Failure to keep your hands away from the blade will result in serious personal injury.
	No Hands Symbol	Failure to keep your hands away from the blade will result in serious personal injury.
	No Hands Symbol	Failure to keep your hands away from the blade will result in serious personal injury.
	Hot Surface	To reduce the risk of injury or damage, avoid contact with any hot surface.

SYMBOLS

The following signal words and meanings are intended to explain the levels of risk associated with this product.

SYMBOL	SIGNAL	MEANING
	DANGER:	Indicates an imminently hazardous situation, which, if not avoided, will result in death or serious injury.
	WARNING:	Indicates a potentially hazardous situation, which, if not avoided, could result in death or serious injury.
	CAUTION:	Indicates a potentially hazardous situation, which, if not avoided, may result in minor or moderate injury.
	CAUTION:	(Without Safety Alert Symbol) Indicates a situation that may result in property damage.

SERVICE

Servicing requires extreme care and knowledge and should be performed only by a qualified service technician. For service we suggest you return the product to your nearest **AUTHORIZED SERVICE CENTER** for repair. When servicing, use only identical replacement parts.



WARNING: To avoid serious personal injury, do not attempt to use this product until you read thoroughly and understand completely the operator's manual. Save this operator's manual and review frequently for continuing safe operation and instructing others who may use this product.

WARNING:



The operation of any power tool can result in foreign objects being thrown into your eyes, which can result in severe eye damage. Before beginning power tool operation, always wear safety goggles or safety glasses with side shields and a full face shield when needed. We recommend Wide Vision Safety Mask for use over eyeglasses or standard safety glasses with side shields. Always use eye protection which is marked to comply with ANSI Z87.1.

SAVE THESE INSTRUCTIONS

FEATURES

PRODUCT SPECIFICATIONS

Motor	19.2 Volts DC
Switch	Variable Speed
No Load Speed	0-3100/min.
Charger Input	120 V, 60 Hz, AC only
Charge Rate	1 hour
Stroke Length	7/8 in.

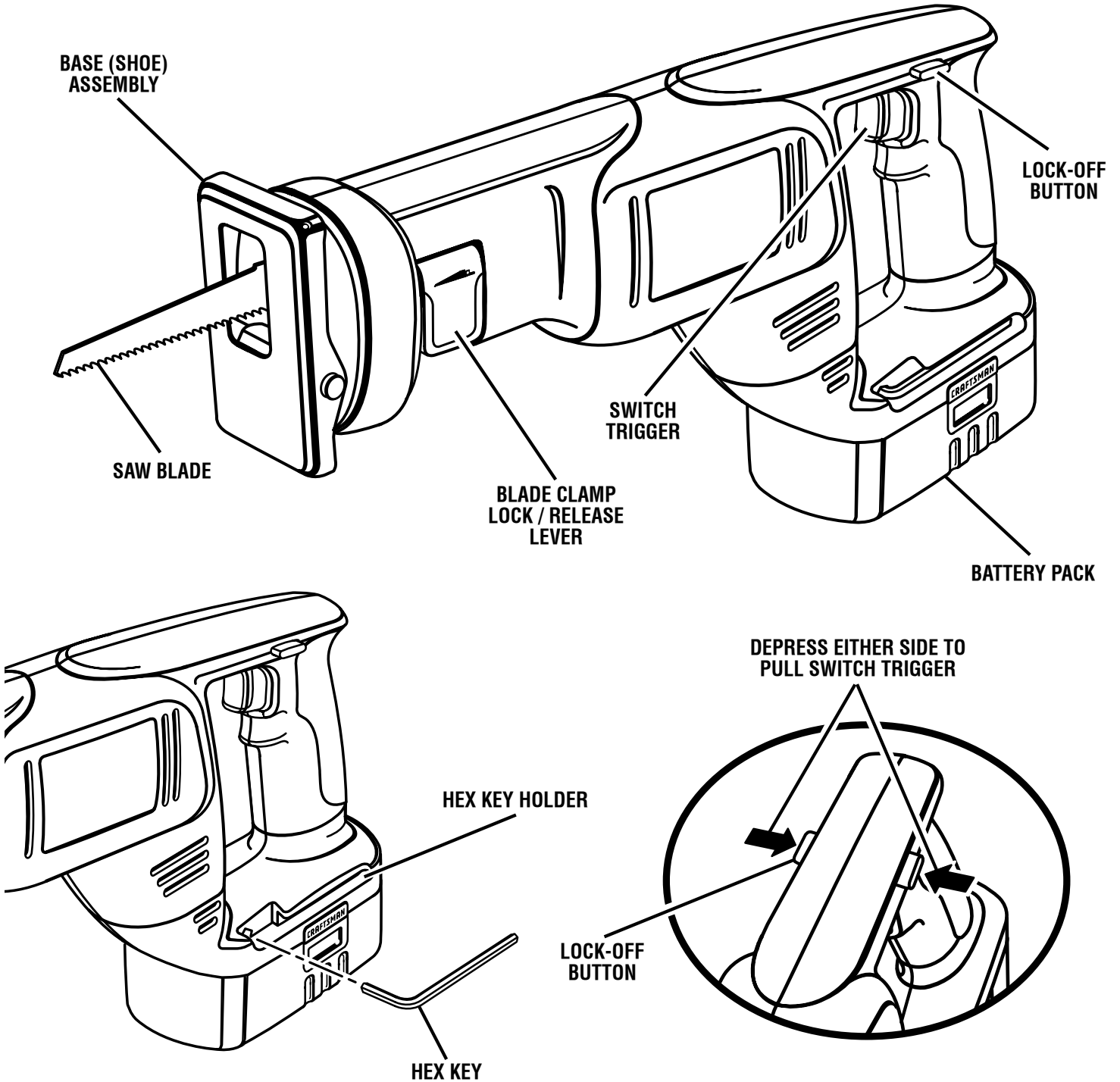

FEATURES

KNOW YOUR RECIPROCATING SAW

See Figure 1.

Before attempting to use this product, familiarize yourself with all operating Features and Safety Rules.

TOOLLESS BLADE CLAMP

Your saw has a blade clamp design that does not require the use of a tool (blade wrench) when installing or removing the blade. Simply lift blade clamp lock / release lever, located on side of saw, insert blade between blade clamp and saw bar as far as possible, then release lever to lock position.

HEX KEY HOLDER

A hex key is packed with your saw. A convenient feature on your saw is the hex key holder. This is a slot located on the bottom portion of the saw handle. It is convenient for storing the hex key when it is not being used.

LOCK-OFF BUTTON

Your saw is equipped with a "lock-off" button which reduces the possibility of accidental starting. The lock-off button is located on the handle above the switch trigger. You must depress the lock-off button in order to pull the switch trigger. The lock resets each time the trigger is released. **NOTE:** You can depress the lock-off button from either the left or right side.

SWITCH

To turn your saw **ON**, depress the lock-off button and pull switch trigger. Release switch trigger to turn your saw **OFF**.

VARIABLE SPEED

This tool has a variable speed switch that delivers higher speed with increased trigger pressure. Speed is controlled by the amount of switch trigger depression.

BLADE SELECTION

To obtain the best performance from your saw it is important to select a specific blade for the particular application and type of material you wish to cut. By doing this you will get a smoother faster cut and prolong blade life. Replacement blades for this saw are available from your nearest Craftsman dealer.

ASSEMBLY

UNPACKING

This product has been shipped completely assembled.

- Carefully remove the tool and any accessories from the box. Make sure that all items listed in the packing list are included.
- Inspect the tool carefully to make sure no breakage or damage occurred during shipping.
- Do not discard the packing material until you have carefully inspected and satisfactorily operated the tool.
- If any parts are damaged or missing, please call 1-800-932-3188 for assistance.

PACKING LIST

Reciprocating Saw

Blades (2)

Battery Pack

Charger

Operator's Manual



WARNING: If any parts are missing do not operate this tool until the missing parts are replaced. Failure to do so could result in possible serious personal injury.



WARNING: Do not attempt to modify this tool or create accessories not recommended for use with this tool. Any such alteration or modification is misuse and could result in a hazardous condition leading to possible serious personal injury.



WARNING: To prevent accidental starting that could cause serious personal injury, always remove the battery pack from the tool when assembling parts.

OPERATION



WARNING: Do not allow familiarity with tools to make you careless. Remember that a careless fraction of a second is sufficient to inflict serious injury.



WARNING: Always wear safety goggles or safety glasses with side shields when operating tools. Failure to do so could result in objects being thrown into your eyes, resulting in possible serious injury.

APPLICATIONS

You may use this tool for the following purposes:

- Cutting all types of wood products (lumber, plywood, paneling, composition board, and hard wood).
- Cutting masonite and plastic.
- Cutting drywall.
- Cutting metals such as sheet steel, pipe, steel rods, aluminum, brass, and copper.

CAUTION: To prevent damage to the battery pack, remove the battery pack from the charger immediately if no LED comes on. Return the battery pack and charger to your nearest service center for checking or replacing. Also, if you are removing the battery pack from the charger and no LEDs are on, return both the battery pack and the charger to your nearest service center. Do not insert another battery pack into the charger. A damaged charger may damage a battery pack.

LED FUNCTIONS OF CHARGER

LED WILL BE ON TO INDICATE STATUS OF CHARGER AND BATTERY PACK:

- Red LED on = Fast charging mode.
- Green LED on = Fully charged and in trickle charge mode.
- Green LED on = When battery pack is inserted into charger, indicates hot battery pack or that battery pack is out of or below normal temperature range.
- Yellow and Green LEDs on = Deeply discharged or defective battery pack.
- No LED on = Defective charger or battery pack.

CHARGING THE BATTERY PACK

The battery pack for this tool has been shipped in a low charge condition to prevent possible problems. Therefore, you should charge it until the green LED on the front of the charger comes on.

NOTE: Batteries will not reach full charge the first time they are charged. Allow several cycles (operation followed by recharging) for them to become fully charged.

OPERATION

CHARGING A COOL BATTERY PACK

See Figure 2.

If battery pack is below normal temperature range, the green LED on charger will come on. Allow battery pack to reach normal temperature, then the red LED will come on.

NOTE: If the charger does not charge the battery pack under normal circumstances, return both the battery pack and charger to your nearest Sears Repair Center for electrical check.

- Charge the battery pack only with the charger provided.
- Make sure the power supply is normal household voltage, **120 volts, 60 Hz, AC only**.
- Connect the charger to the power supply.
- Place the battery pack in the charger aligning raised rib on the battery pack with the groove in the charger.
- Press down on the battery pack to be sure contacts on the battery pack engage properly with contacts in the charger.
- Normally the red LED on charger will come on. This indicates the charger is in fast charging mode.
- Red LED should remain on for approximately 1 hour then the green LED will come on. Green LED on indicates battery pack is fully charged and charger is in maintenance charge mode.

NOTE: The green LED will remain on until the battery pack is removed from the charger or charger is disconnected from the power supply.

- If both yellow and green LEDs come on, this indicates a deeply discharged or defective battery pack. Allow the battery pack to remain in the charger for 15 to 30 minutes. When the battery pack reaches normal voltage range, the red LED should come on. If the red LED does not come on after 30 minutes, this may indicate a defective battery pack and should be replaced.

BATTERY PACK SHOWN
IN CHARGER

CHARGER

RED LED ON INDICATES
FAST CHARGING MODE

GREEN LED ON AFTER FAST CHARGING CYCLE,
INDICATES FULLY CHARGED BATTERY PACK
AND IN TRICKLE CHARGE MODE.

YELLOW AND GREEN LEDS ON INDICATES DEEPLY
DISCHARGED OR DEFECTIVE BATTERY PACK.

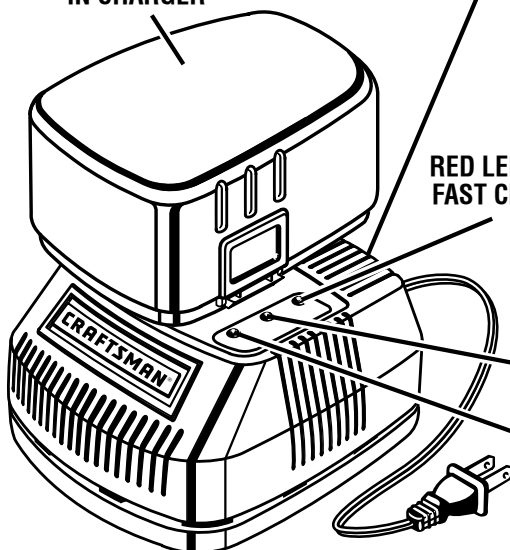

- After normal usage, a minimum of 1 hour of charging time is required to fully recharge battery pack.
- The battery pack will become slightly warm to the touch while charging. This is normal and does not indicate a problem.
- Do not place the charger and battery pack in an area of extreme heat or cold. They will work best at normal room temperature.

NOTE: The charger and battery pack should be placed in a location where the temperature is more than 50°F but less than 100°F.

- When batteries become fully charged, unplug the charger from power supply and remove the battery pack.

CHARGING A HOT BATTERY PACK

When using the tool continuously, the batteries in the battery pack will become hot. You should let a hot battery pack cool down for approximately 30 minutes before attempting to recharge. When the battery pack becomes discharged and is hot, this will cause the green LED to come on instead of the red LED. After 30 minutes, reinsert the battery pack in the charger. If the green LED continues to remain on, return battery pack to your nearest Sears Repair Center for checking or replacing.

NOTE: This situation only occurs when continuous use of the tool causes the batteries to become hot. It does not occur under normal circumstances. Refer to “**CHARGING A COOL BATTERY PACK**” for normal recharging of batteries. If the charger does not charge your battery pack under normal circumstances, return both the battery pack and charger to your nearest Sears Repair Center for electrical check.

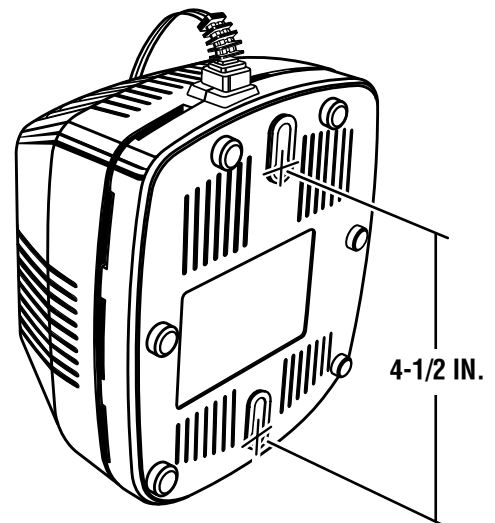

Fig. 2

OPERATION

TO REMOVE / ATTACH BATTERY PACK

See Figure 3.

TO REMOVE:

- Locate latches on side of battery pack and depress both sides to release battery pack from your saw.
- Remove battery pack from your saw.

TO ATTACH:

- Place the battery pack in your saw aligning raised rib on battery pack with groove in saw's battery port.
- Make sure the latches on each side of the battery pack snap into place and battery pack is secured to saw before beginning operation.

CAUTION: When placing battery pack in the tool, be sure raised rib on battery pack aligns with the bottom of the saw and latches into place properly. Improper installation of the battery pack can cause damage to internal components.

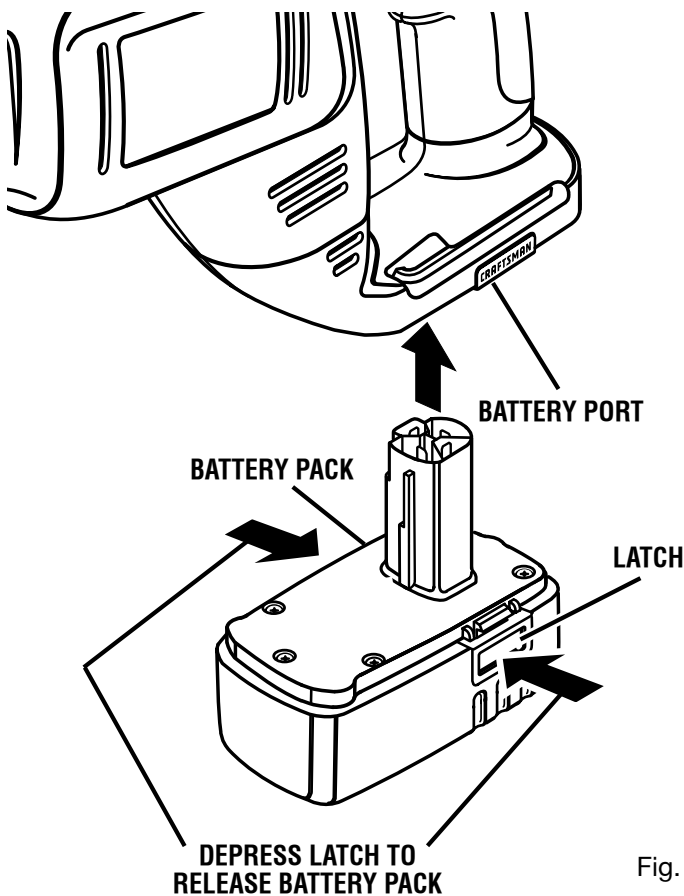

Fig. 3

TO INSTALL SAW BLADE

See Figure 4.

- Remove battery pack.

WARNING: Failure to remove battery pack from saw could result in accidental starting causing possible serious personal injury.

- Lift blade clamp lock / release lever located on side of saw.
- Insert saw blade between blade clamp and saw bar.
- Lock blade clamp lever.
- Replace battery pack.

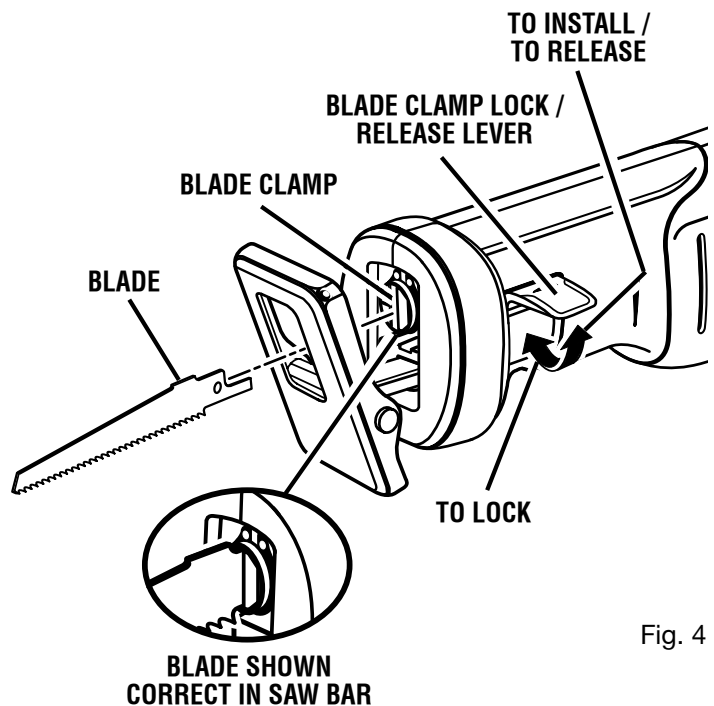

Fig. 4

OPERATION

BASE (SHOE) ASSEMBLY

See Figure 5.

The base assembly of your reciprocating saw pivots up and down in both directions. It also is adjustable, allowing the use of the blade teeth at different positions on the blade.

TO CHANGE POSITIONS OF BASE ASSEMBLY:

- Remove battery pack.

⚠ WARNING: Failure to remove battery pack from saw could result in accidental starting causing possible serious personal injury.

- Loosen the set screw in the gear frame with the hex key provided with this saw.
- Reposition base assembly to desired position.
- Retighten set screw securely. **Do not** overtighten screw or use an aid with the hex key.
- Remove hex key and store it in the hex key holder.

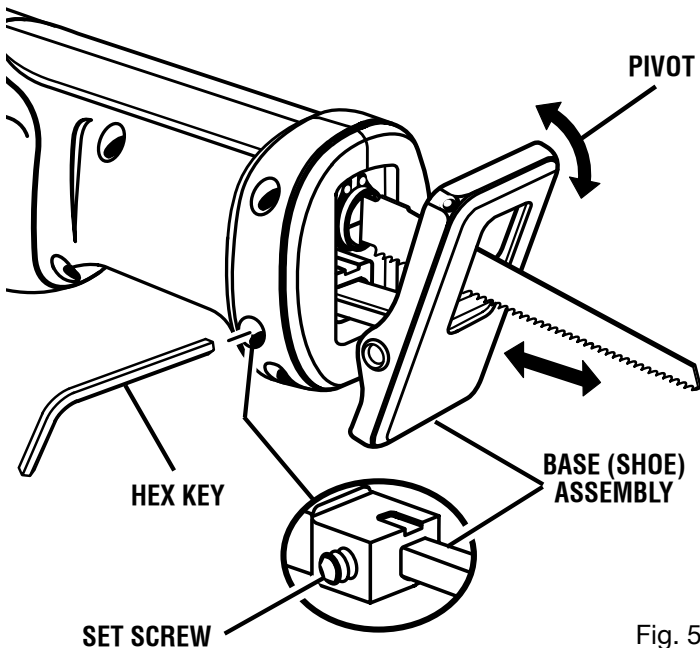

Fig. 5

GENERAL CUTTING

See Figure 6.

Hold your saw firmly in front of and clearly away from you. Make sure saw blade is clear of any foreign material. Be sure material to be cut is held firmly. Small work pieces should be securely clamped in a vise or with clamps to the work bench or table. Mark the line of cut clearly. Depress the lock-off button, then pull switch trigger to start the cutting action. Place the base assembly against the work, then move the blade into the work. **Do not force.** Use only enough pressure to keep the saw cutting. Let the blade and saw do the work. Use of excessive pressure that causes bending or twisting of the blade may result in broken blades.

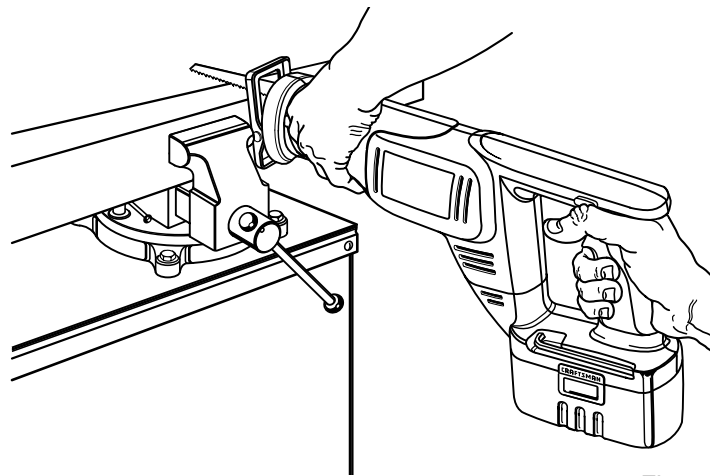

Fig. 6

OPERATION

PLUNGE CUTTING

See Figure 7.

Mark the line of cut clearly. Choose a convenient starting point inside the area to be cut out and place the tip of the blade over that point. Rest front edge of base (shoe) assembly on work and hold firmly in position. Depress the lock-off button, then pull switch trigger to start the cutting action.

⚠ WARNING: Make sure blade does not touch work until motor reaches full speed, since this could cause loss of control resulting in serious injury.

With saw blade at full cutting speed, slowly tilt saw downward until tip of blade starts cutting work. After blade penetrates work, tilt saw until blade is perpendicular to the work.

Never use gasoline since normal sparking of motor could ignite fumes. Clamp the work firmly and cut close to the clamping point to eliminate any vibration of the work being cut. When cutting conduit pipe or angle iron, clamp work in a vise if possible and cut close to the vise. To cut thin sheet material, "sandwich" the material between hardboard or plywood and clamp the layers to eliminate vibration and material tearing.

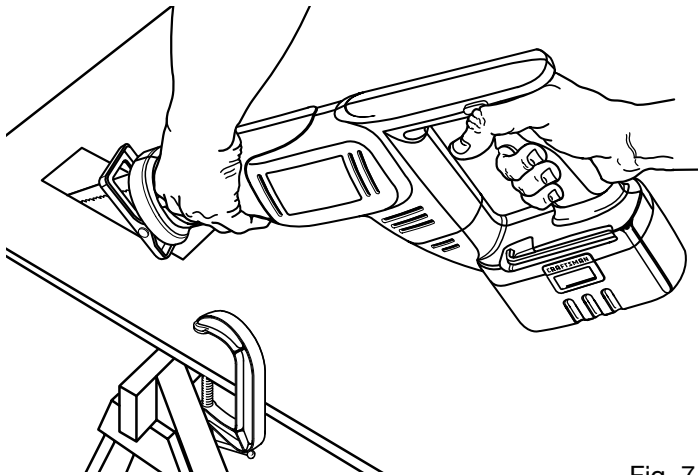

Fig. 7

METAL CUTTING

See Figure 8.

Metals such as sheet steel, pipe, steel rods, aluminum, brass, and copper may be cut with your saw. Be careful not to twist or bend the saw blade. **Do not force.** We recommend cutting oil when cutting most soft metals and steel. Cutting oil will also keep blades cool, increase cutting action, and prolong blade life.

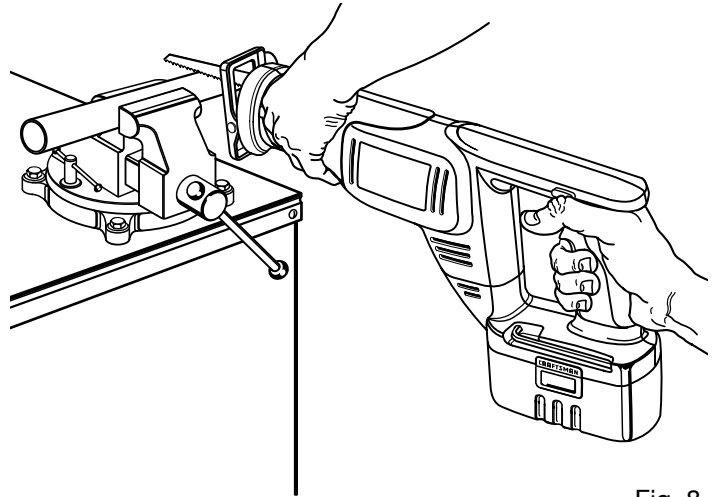

Fig. 8

MAINTENANCE

⚠ WARNING: When servicing, use only identical Craftsman replacement parts. Use of any other part may create a hazard or cause product damage.

⚠ WARNING: Always wear safety goggles or safety glasses with side shields when using compressed air to clean tools. If the operation is dusty, also wear a dust mask.

⚠ WARNING: To avoid serious personal injury, always remove the battery pack from the tool when cleaning or performing any maintenance.

⚠ WARNING: Do not at any time let brake fluids, gasoline, petroleum-based products, penetrating oils, etc. come in contact with plastic parts. Chemicals can damage, weaken or destroy plastic which may result in serious personal injury.

Only the parts shown on the parts list are intended to be repaired or replaced by the customer. All other parts should be replaced at a Sears Service Center.

GENERAL MAINTENANCE

Avoid using solvents when cleaning plastic parts. Most plastics are susceptible to damage from various types of commercial solvents and may be damaged by their use. Use clean cloths to remove dirt, dust, oil, grease, etc.

BATTERIES

The battery pack for this tool is equipped with nickel-cadmium rechargeable batteries. Length of service from each charging will depend on the type of work you are doing.

The batteries in this tool have been designed to provide maximum trouble-free life. However, like all batteries, they will eventually wear out. **Do not** disassemble battery pack and attempt to replace the batteries. Handling of these batteries, especially when wearing rings and jewelry, could result in a serious burn.

To obtain the longest possible battery life, we suggest the following:

- Remove the battery pack from the charger once it is fully charged and ready for use.
- Store the battery pack where the temperatures is below 80°F.
- Store battery packs in a "discharged" condition.

BATTERY PACK REMOVAL AND PREPARATION FOR RECYCLING



To preserve natural resources, please recycle or dispose of batteries properly.

This product contains nickel-cadmium batteries. Local, state or federal laws may prohibit disposal of nickel-cadmium batteries in ordinary trash.

Consult your local waste authority for information regarding available recycling and/or disposal options.

⚠ WARNING: Upon removal, cover the battery pack's terminals with heavy-duty adhesive tape. Do not attempt to destroy or disassemble battery pack or remove any of its components. Nickel-cadmium batteries must be recycled or disposed of properly. Also, never touch both terminals with metal objects and/or body parts as short circuit may result. Keep away from children. Failure to comply with these warnings could result in fire and/or serious injury.

ACCESSORIES

The following recommended accessories are currently available at Sears retail stores:

BLADE TYPES	LENGTH IN.	TEETH PER IN.
For fast smooth cuts in woods, masonite, plastics, hard composition board and all plunge cutting. Keyhole blade shape permits cutting in hard to reach areas.....	6	6
For fast, smooth, deep cuts through thick wood, plastic, composition board, and hardboard.....	12	6
For rough cuts in wood.	12	6
High speed steel blade for cutting ferrous metals less than 1/8 in. thick and for cutting tubing or pipe with a 1/8 in. thick wall section or less.	4	24

 **WARNING:** Current attachments and accessories available for use with this tool are listed above. Do not use any attachments or accessories not recommended by the manufacturer of this tool. The use of attachments or accessories not recommended can result in serious personal injury.

CRAFTSMAN 19.2 VOLT RECIPROCATING SAW – MODEL NO. 315.114270

The model number will be found on a plate attached to the motor housing. Always mention the model number in all correspondence regarding your **19.2 VOLT RECIPROCATING SAW** or when ordering repair parts.

SEE BACK PAGE FOR PARTS ORDERING INSTRUCTIONS

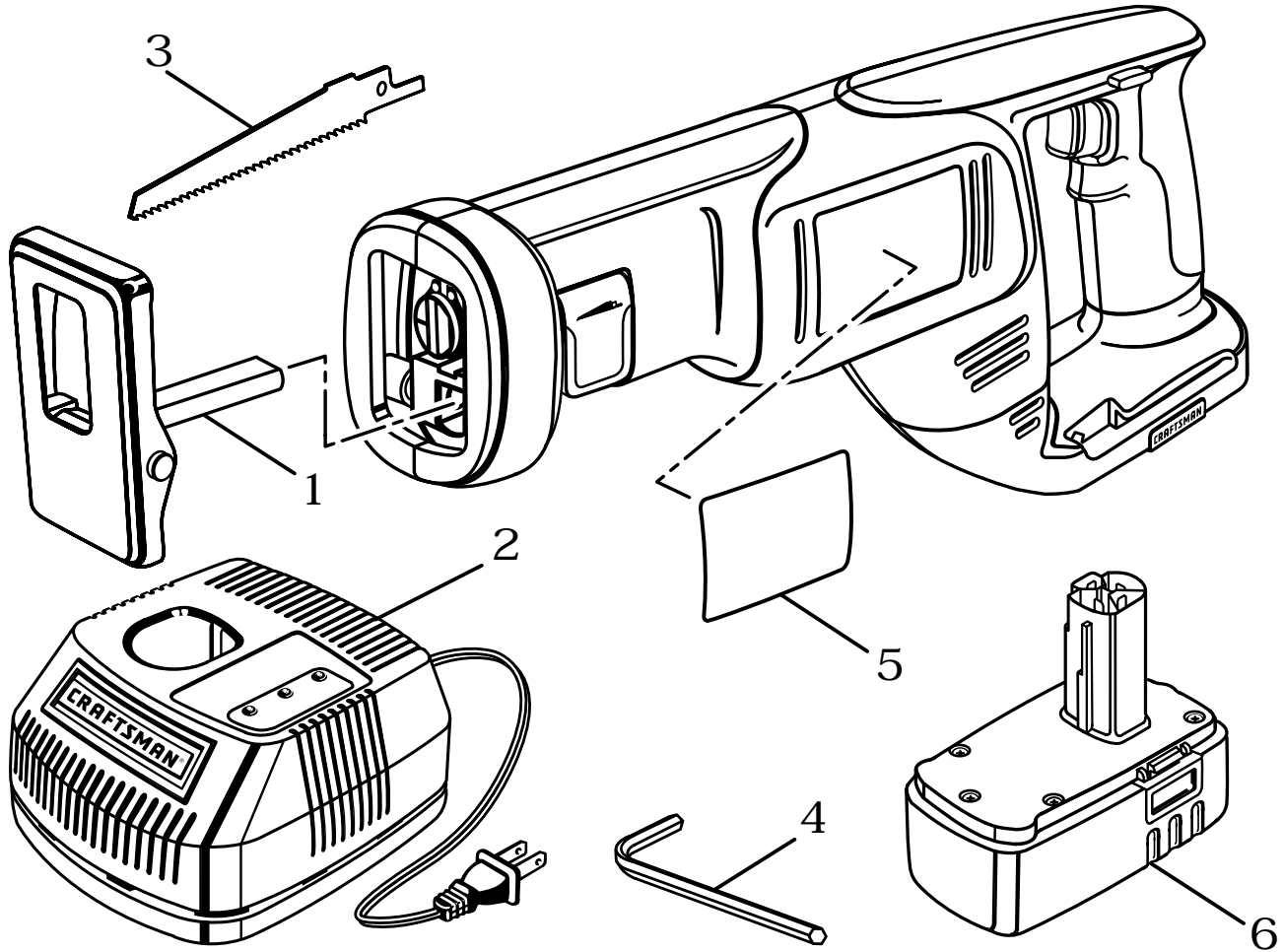

PARTS LIST

Key No.	Part Number	Description	Qty.
1	3021608	Base (Shoe) Assembly	1
2	* 9 11041	Charger (1425301)	1
3	6929101	Saw Blade (Wood cutting)	1
	6929201	Saw Blade (Metal cutting)	1
4	6800201	Hex Key	1
5	9421334	Logo Plate	1
6	* 9 11375	Battery Pack (1323517, 1323903)	1
	3073068	Carrying Case (not shown) (11427)	1
	3073062	Carrying Case (not shown) (when included in 11432 Combo)	1
	983000-193	Operator's Manual	

* Can Be Purchased Thru RSOS (Retail Special Order System)

Get it fixed, at your home or ours!

Your Home

For repair – **in your home** – of **all** major brand appliances, lawn and garden equipment, or heating and cooling systems, **no matter who made it, no matter who sold it!**

For the replacement parts, accessories and owner's manuals that you need to do-it-yourself.

For Sears professional installation of home appliances and items like garage door openers and water heaters.

1-800-4-MY-HOME® (1-800-469-4663)

Call anytime, day or night (U.S.A. and Canada)

www.sears.com www.sears.ca

Our Home

For repair of carry-in items like vacuums, lawn equipment, and electronics, call or go on-line for the location of your nearest **Sears Parts & Repair Center.**

1-800-488-1222

Call anytime, day or night (U.S.A. only)

www.sears.com

To purchase a protection agreement (U.S.A.) or maintenance agreement (Canada) on a product serviced by Sears:

1-800-827-6655 (U.S.A.)

1-800-361-6665 (Canada)

Para pedir servicio de reparación a domicilio, y para ordenar piezas:

1-888-SU-HOGARSM

(1-888-784-6427)

Au Canada pour service en français:

1-800-LE-FOYER^{MC}

(1-800-533-6937)

www.sears.ca

SEARS

Operator's Manual

CRAFTSMAN®

19.2 VOLT FLUORESCENT LIGHT

Model No.
315.114071

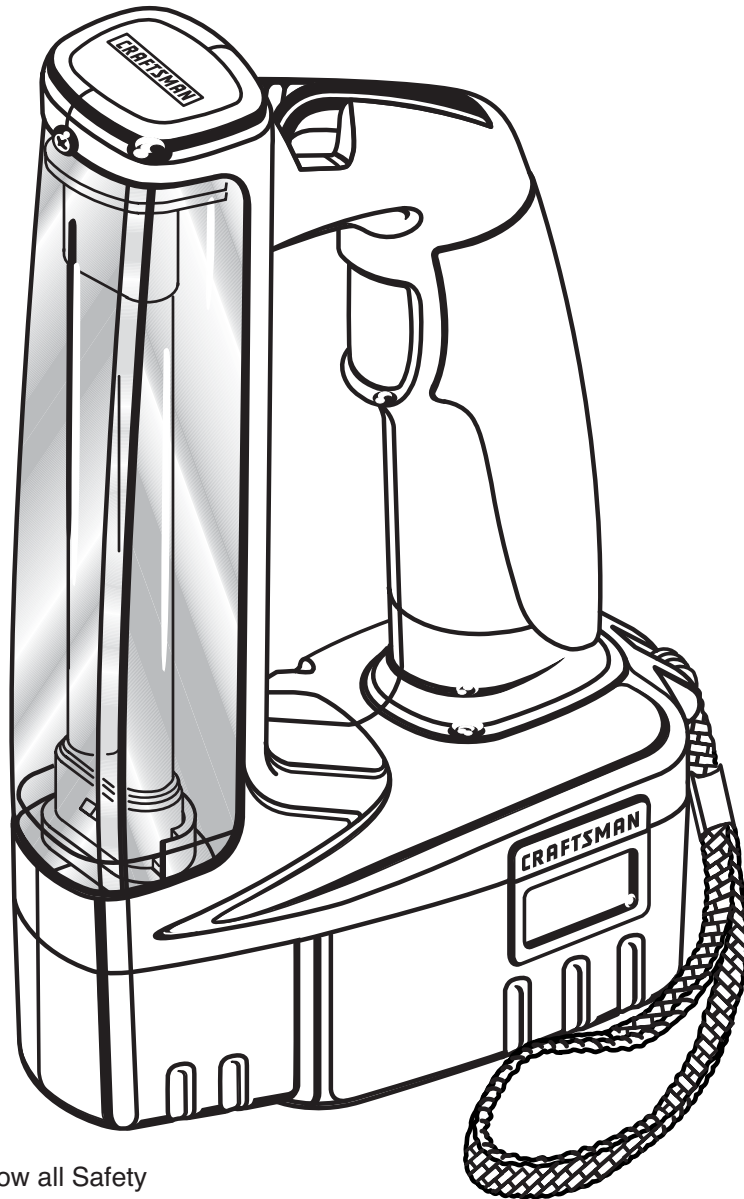

Save this manual for
future reference

⚠ CAUTION: Read and follow all Safety Rules and Operating Instructions before first use of this product.

- Safety
- Operation
- Maintenance

Customer Help Line: 1-800-932-3188

Sears, Roebuck and Co., 3333 Beverly Rd., Hoffman Estates, IL 60179 USA
Visit the Craftsman web page: www.sears.com

983000-199
2-03



TABLE OF CONTENTS

■ Warranty	2
■ Introduction	2
■ General Safety Rules	3
■ Specific Safety Rules	4-5
■ Symbols	6
■ Operation	7-8
■ Maintenance	9-10
■ Parts, Ordering, and Service	12

WARRANTY

FULL ONE YEAR WARRANTY ON CRAFTSMAN FLUORESCENT LIGHT

If this **CRAFTSMAN Fluorescent Light** fails to give complete satisfaction within one year from the date of purchase, **RETURN IT TO THE NEAREST SEARS STORE IN THE UNITED STATES**, and Sears will repair it, free of charge.

If this **CRAFTSMAN Fluorescent Light** is used for commercial or rental purposes, this warranty applies for only 90 days from the date of purchase.

This warranty gives you specific legal rights, and you may also have other rights which vary from state to state.

Sears, Roebuck and Co., Dept. 817WA, Hoffman Estates, IL 60179

INTRODUCTION

Your fluorescent light has many features for making the use of this product more pleasant and enjoyable. Safety, performance, and dependability have been given top priority in the design of this product making it easy to maintain and operate.



WARNING: Do not attempt to use this product until you thoroughly read and completely understand the operator's manual. Pay close attention to the safety rules, including Dangers, Warnings, and Cautions. If you use this product properly and only as intended, you will enjoy years of safe, reliable service.

 Look for this symbol to point out important safety precautions. It means attention!!! Your safety is involved.

 **WARNING:**



The operation of any power tool can result in foreign objects being thrown into your eyes, which can result in severe eye damage. Before beginning power tool operation, always wear safety goggles or safety glasses with side shields and a full face shield when needed. We recommend Wide Vision Safety Mask for use over eyeglasses or standard safety glasses with side shields, available at Sears Retail Stores. Always wear eye protection which is marked to comply with ANSI Z87.1.

GENERAL SAFETY RULES

- ⚠ WARNING: Read and understand all instructions.** Failure to follow all instructions listed below, can result in electric shock, fire and/or serious personal injury.

SAVE THESE INSTRUCTIONS

WORK AREA

- **Keep your work area clean and well lit.** Cluttered benches and dark areas invite accidents.

ELECTRICAL SAFETY

- **Do not abuse the cord. Never use the cord to carry the charger. Keep cord away from heat, oil, sharp edges, or moving parts. Replace damaged cords immediately.** Damaged cords may create a fire.
- **A battery operated tool with integral batteries or a separate battery pack must be recharged only with the specified charger for the battery.** A charger that may be suitable for one type of battery may create a risk of fire when used with another battery. Use battery only with charger listed.
- **Use battery operated tool only with specifically designated battery pack.** Use of any other batteries may create a risk of fire. Use only with battery pack listed.

PERSONAL SAFETY

- **Stay alert, watch what you are doing and use common sense when operating a power tool. Do not use tool while tired or under the influence of drugs, alcohol, or medication.** A moment of inattention while operating power tools may result in serious personal injury.

- **Do not overreach. Keep proper footing and balance at all times.** Proper footing and balance enable better control of the tool in unexpected situations. Do not use on a ladder or unstable support.

TOOL USE AND CARE

- **Disconnect battery pack from tool before making any adjustments, changing accessories, or storing the tool.** Such preventive safety measures reduce risk of starting the tool accidentally.
- **Store idle tools out of reach of children and other untrained persons.** Tools are dangerous in the hands of untrained users.
- **Check for misalignment or binding of moving parts, breakage of parts, and any other condition that may affect the tool's operation. If damaged, have the tool serviced before using.** Many accidents are caused by poorly maintained tools.
- **Use only accessories that are recommended by the manufacturer for your model.** Accessories that may be suitable for one tool, may create a risk of injury when used on another tool.

SERVICE

- **Tool service must be performed only by qualified repair personnel.** Service or maintenance performed by unqualified personnel could result in a risk of injury.
- **When servicing a tool, use only identical replacement parts. Follow instructions in the Maintenance section of this manual.** Use of unauthorized parts or failure to follow Maintenance Instructions may create a risk of shock or injury.

SPECIFIC SAFETY RULES

Hold tool by insulated gripping surfaces when performing an operation where the cutting tool may contact hidden wiring. Contact with a "live" wire will make exposed metal parts of the tool "live" and shock the operator.

ADDITIONAL RULES FOR SAFE OPERATION

- **Know your power tool. Read operator's manual carefully. Learn its applications and limitations, as well as the specific potential hazards related to this tool.** Following this rule will reduce the risk of electric shock, fire, or serious injury.

IMPORTANT RULES FOR BATTERY TOOLS

- **USE ONLY THE CHARGER RECOMMENDED FOR USE WITH YOUR FLASHLIGHT.** Do not substitute any other charger. Use of another charger could cause batteries to explode causing possible serious injury.
- **Battery tools do not have to be plugged into an electrical outlet; therefore, they are always in operating condition. Be aware of possible hazards when not using your battery tool or when changing accessories.** Following this rule will reduce the risk of electric shock, fire, or serious personal injury.
- **Do not place battery tools or their batteries near fire or heat.** This will reduce the risk of explosion and possibly injury.
- **Do not charge battery tool in a damp or wet location.** Following this rule will reduce the risk of electric shock.
- **For best results, your battery tool should be charged in a location where the temperature is more than 50°F but less than 100°F. Do not store outside or in vehicles.**

- **Under extreme usage or temperature conditions, battery leakage may occur. If liquid comes in contact with your skin, wash immediately with soap and water, then neutralize with lemon juice or vinegar. If liquid gets into your eyes, flush them with clean water for at least 10 minutes, then seek immediate medical attention.** Following this rule will reduce the risk of serious personal injury.



WARNING: Batteries vent hydrogen gas and can explode in the presence of a source of ignition, such as a pilot light. To reduce the risk of serious personal injury, never use any cordless product in the presence of open flame. An exploded battery can propel debris and chemicals. If exposed, flush with water immediately.



WARNING: Never use a battery pack that has been damaged or received a sharp blow. A damaged battery pack is subject to explosion. Properly dispose of a damaged battery pack immediately. Failure to heed this warning can result in serious personal injury.



WARNING: This light is not a toy and should not be used by children.

SPECIFIC SAFETY RULES

IMPORTANT SAFETY INSTRUCTIONS FOR CHARGER

- **Save these instructions. This manual contains important safety and operating instructions for charger.** Following this rule will reduce the risk of electric shock, fire, or serious personal injury.
- **Before using battery charger, read all instructions and cautionary markings in this manual, on battery charger, and product using battery charger.** Following this rule will reduce the risk of electric shock, fire, or serious personal injury.
- **To reduce risk of injury, charge only nickel-cadmium type rechargeable batteries. Other types of batteries may burst causing personal injury and damage.** Following this rule will reduce the risk of electric shock, fire, or serious personal injury.
- **Do not expose charger to wet or damp conditions.** Following this rule will reduce the risk of electric shock, fire, or serious personal injury.
- **Use of an attachment not recommended or sold by the battery charger manufacturer may result in a risk of fire, electric shock, or injury to persons.** Following this rule will reduce the risk of electric shock, fire, or serious personal injury.
- **To reduce risk of damage to charger body and cord, pull by charger plug rather than cord when disconnecting charger.** Following this rule will reduce the risk of electric shock, fire, or serious personal injury.
- **Make sure cord is located so that it will not be stepped on, tripped over, or otherwise subjected to damage or stress.** Following this rule will reduce the risk of serious personal injury.
- **An extension cord should not be used unless absolutely necessary.** Use of improper extension cord could result in a risk of fire and electric shock. If extension cord must be used, make sure:

- a. That pins on plug of extension cord are the same number, size and shape as those of plug on charger.
- b. That extension cord is properly wired and in good electrical condition; and
- c. That wire size is large enough for AC ampere rating of charger as specified below:

Cord Length (Feet)	25'	50'	100'
Cord Size (AWG)	16	16	16



Note: AWG = American Wire Gage

- **Do not operate charger with a damaged cord or plug. If damaged, have replaced immediately by a qualified serviceman.** Following this rule will reduce the risk of electric shock, fire, or serious personal injury.
- **Do not operate charger if it has received a sharp blow, been dropped, or otherwise damaged in any way; take it to a qualified serviceman.** Following this rule will reduce the risk of electric shock, fire, or serious personal injury.
- **Do not disassemble charger; take it to a qualified serviceman when service or repair is required. Incorrect reassembly may result in a risk of electric shock or fire.** Following this rule will reduce the risk of electric shock, fire, or serious personal injury.
- **To reduce the risk of electric shock, unplug charger from outlet before attempting any maintenance or cleaning. Turning off controls will not reduce this risk.** Following this rule will reduce the risk of electric shock, fire, or serious personal injury.
- **Disconnect charger from power supply when not in use.** Following this rule will reduce the risk of electric shock, fire, or serious personal injury.
- **Save these instructions. Refer to them frequently and use them to instruct others who may use this tool. If you loan someone this tool, loan them these instructions also.** Following this rule will reduce the risk of electric shock, fire, or serious personal injury.

SAVE THESE INSTRUCTIONS

SYMBOLS

Important: Some of the following symbols may be used on your tool. Please study them and learn their meaning. Proper interpretation of these symbols will allow you to operate the tool better and safer.

SYMBOL	NAME	DESIGNATION/EXPLANATION
V	Volts	Voltage
A	Amperes	Current
Hz	Hertz	Frequency (cycles per second)
min	Minutes	Time
~	Alternating Current	Type or a characteristic of current
==	Direct Current	Type or a characteristic of current
n_0	No Load Speed	Rotational speed, at no load
.../min	Revolutions or Reciprocation Per Minute	Revolutions, strokes, surface speed, orbits etc. per minute
	Safety Alert Symbol	Indicates danger, warning or caution. It means attention!!! Your safety is involved.
	Wet Conditions Alert	Do not expose to rain or use in damp locations.
	Hot Surface. Do Not Touch	This decal indicates HOT SURFACE. DO NOT TOUCH. Keep all body parts away from all hot surfaces.

The purpose of safety symbols is to attract your attention to possible dangers. The safety symbols, and the explanations with them, deserve your careful attention and understanding. The safety warnings do not by themselves eliminate any danger. The instructions or warnings they give are not substitutes for proper accident prevention measures.

SYMBOL MEANING



DANGER: Failure to obey a safety warning will result in serious injury to yourself or to others. Always follow the safety precautions to reduce the risk of fire, electric shock and personal injury.



WARNING: Failure to obey a safety warning can result in serious injury to yourself or to others. Always follow the safety precautions to reduce the risk of fire, electric shock and personal injury.



CAUTION: Failure to obey a safety warning may result in property damage or personal injury to yourself or to others. Always follow the safety precautions to reduce the risk of fire, electric shock and personal injury.

NOTE: Advises you of information or instructions vital to the operation or maintenance of the equipment.

OPERATION

BATTERY PACK/CHARGER

If not purchased as a kit, the battery pack and charger are not included with your light. They are both sold separately. If you need to purchase the battery pack and charger, use the following information:

MODEL NO.	BATTERY PACK	CHARGER
315.114071	Item No. 9 11375 (1323517 or 1323903)	Item No. 9 11041 (1425301)

BATTERY PACK

The battery pack for this light has been shipped in a low charge condition to prevent possible problems. Therefore, you should charge it until light on front of charger changes from red to green.

Note: Batteries will not reach full charge the first time they are charged. Allow several cycles (operating light followed by recharging) for batteries to become fully charged.

CHARGING BATTERY PACK

See Figure 1.

- Use only the recommended battery pack and charger with the light.
- **Make sure power supply is normal household voltage, 120 Volts, 60 Hz, AC only.**
- Connect charger to power supply.
- Place battery pack in charger aligning raised rib on battery pack with groove in charger. See Figure 1.
- Press down on battery pack to be sure contacts on battery pack engage properly with contacts in charger.
- Normally, the red LED on charger will come on. This indicates charger is in fast charging mode.
- Red LED should remain on for approximately 1 hour then the green LED will come on. Green LED on indicates battery pack is fully charged and charger is in trickle charge mode. **Note:** Green LED will remain on until battery pack is removed from charger or charger is disconnected from power supply.
- If both yellow and green LED come on, this indicates a deeply discharged or defective battery pack.

Allow battery pack to remain in charger for 15 to 30 minutes. When battery pack reaches normal voltage range, red LED should come on.

If red LED does not come on after 30 minutes, this indicates a defective battery pack and should be replaced.

- After normal usage, a minimum of 1 hour of charging time is required to fully recharge battery pack.
 - The battery pack will become slightly warm to the touch while charging. This is normal and does not indicate a problem.
 - **Do not** place charger and battery pack in an area of extreme heat or cold. It will work best at normal room temperature.
- Note:** Charger and battery pack should be placed in a location where the temperature is more than 50°F but less than 100°F.
- When batteries become fully charged, unplug charger from power supply and remove the battery pack.

IMPORTANT INFORMATION FOR RECHARGING HOT BATTERY PACK

When using the light continuously, the batteries in the battery pack will become hot. You should let a hot battery pack cool down for approximately 30 minutes before attempting to recharge. When the battery pack becomes discharged and is hot, this will cause the green LED to come on instead of the red LED. After 30 minutes, reinsert battery pack in charger. If green LED continues to remain on, return battery pack to your nearest Sears Repair Center for checking or replacing.

Note: This situation only occurs when continuous use of your light causes the batteries to become hot. It does not occur under normal circumstances. Refer to "**CHARGING BATTERY PACK**" for normal recharging of batteries. If the charger does not charge the battery pack under normal circumstances, return **both** the battery pack and charger to the nearest Sears Repair Center for electrical check.

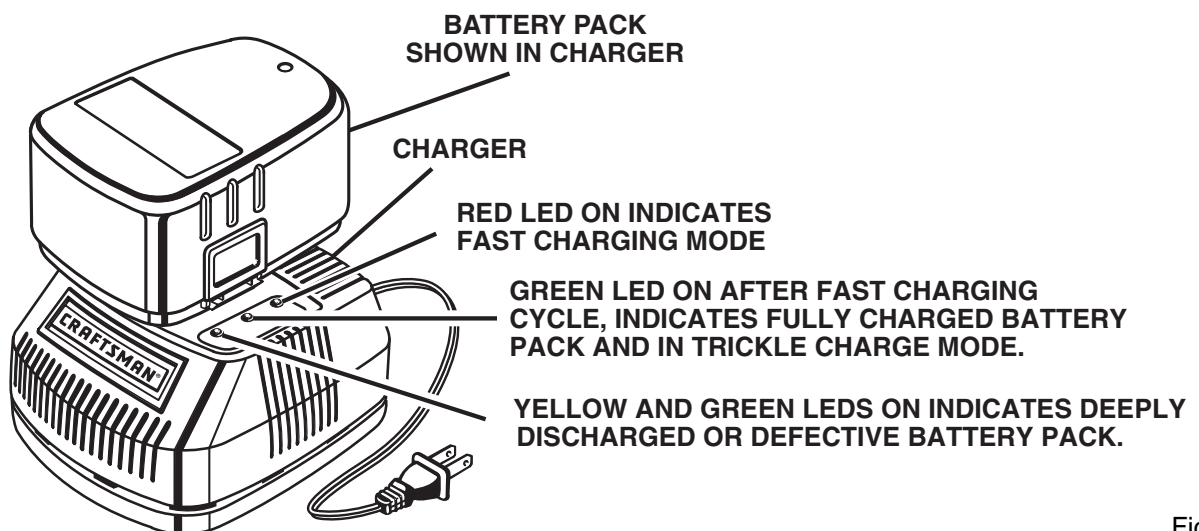

OPERATION

LED FUNCTIONS OF CHARGER LED WILL BE ON TO INDICATE STATUS OF CHARGER AND BATTERY PACK:

- Red LED on = Fast charging mode.
- Green LED on = Fully charged and in trickle charge mode.
- Green LED on = When battery pack is inserted into charger, indicates hot battery pack or that battery pack is out of or below normal temperature range.
- Yellow and Green LEDs on = Deeply discharged or defective battery pack.
- No LED on = Defective charger or battery pack.

CAUTION: To prevent damage to battery pack, remove battery pack from charger immediately if no LED comes on. Return battery pack and charger to your nearest Sears Service Center for checking or replacing. Also, if you are removing battery pack from charger and no LEDs are on, return both battery pack and charger to your nearest Sears Service Center. Do not insert another battery pack into charger. A damaged charger may damage a battery pack.

TO INSTALL OR REMOVE BATTERY PACK

See Figure 2.

- Use only the recommended battery pack with your light.

WARNING: Do not install battery pack to your light until you have read and understood all precautions and operating instructions in the manual and printed on battery pack and charger.

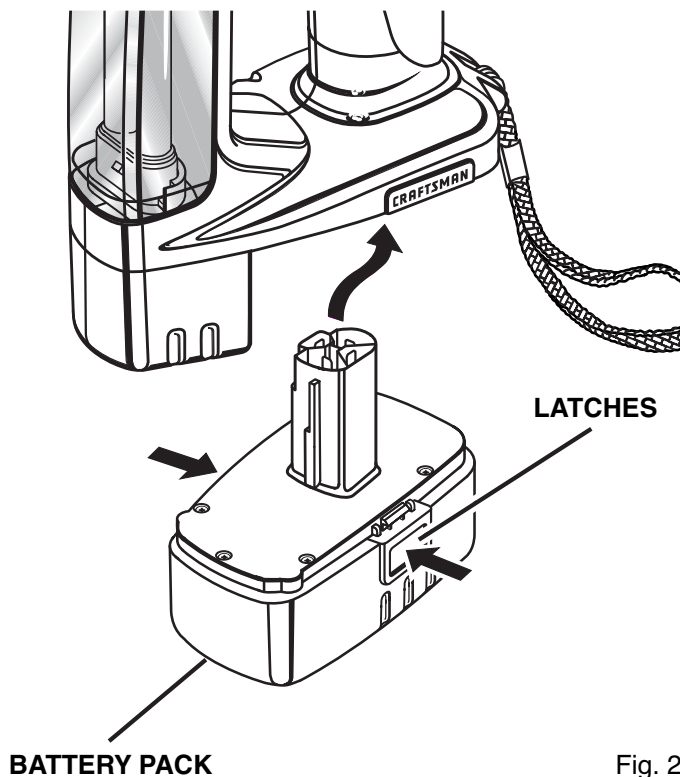

Fig. 2

- Orient battery pack so that raised rib on battery pack aligns with groove inside light handle. Battery pack is designed to fit only one way into light handle.
- Insert battery pack, making sure latches on each side of battery pack snap into place and battery pack is secure in light before use.

CAUTION: When placing battery pack in your light, be sure raised rib on battery pack aligns with groove inside light handle and latches snap into place properly. Improper assembly of battery pack can cause damage to internal components.

- To remove battery pack, locate latches on end of battery pack and depress to release battery pack from your light.

SWITCH

See Figure 3.

To turn light on and off, depress switch trigger.

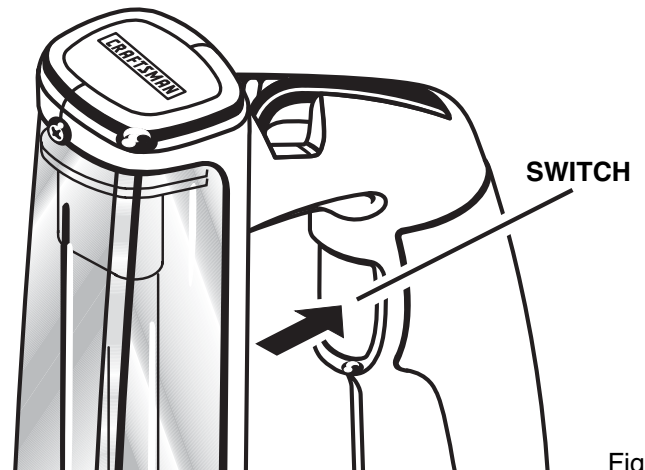

Fig. 3

HANGING / STORAGE FEATURE

See Figure 4.

On top of the housing is a hook in which you can use to hang the light up. This is a good feature for storing light when not in use and also to keep light out of the reach of children. To use, simply lift up on hook.

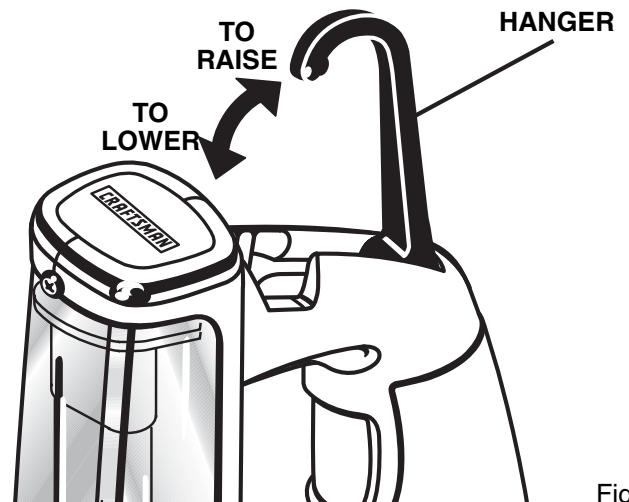

Fig 4

MAINTENANCE

WARNING: When servicing, use only identical Craftsman replacement parts. Use of any other part may create a hazard or cause product damage.

WARNING: Do not at any time let brake fluids, gasoline, petroleum-based products, penetrating oils, etc. come in contact with plastic parts. They contain chemicals that can damage, weaken or destroy plastic.

Do not abuse power tools. Abusive practices can damage tool as well as workpiece.

WARNING: Do not attempt to modify this worklight or create accessories not recommended for use with this worklight. Any such alteration or modification is misuse and could result in a hazardous condition leading to possible serious personal injury.

FLUORESCENT TUBE REPLACEMENT

See Figure 4.

When purchasing replacement fluorescent tube, request recommended part number 7819602. See Figure 5.

TO REPLACE FLUORESCENT TUBE:

- Remove battery pack from worklight. See Page 8.
- Remove screw to release lens cover. Remove lens cover by pulling forward and lifting from the housing.
- To remove old fluorescent tube from spring, gently grasp the lower edge of the rubber cushion and sides of bulb. Carefully work tube in a side-to-side motion while easing tube forward and up until tube is free from the spring. Do not pull fluorescent tube straight out from its center, as this increases chance of breakage.
- Remove rubber cushion from old fluorescent tube and place on top of new tube, rounded edge facing outward.
- Insert new fluorescent tube in spring by aligning prongs on tube with holes in tube socket area. Gently push down on base of new tube until fully engaged. Do not force tube into place.
- Replace lens cover by sliding lower edge into housing. Align screw holes at top. With a hand tool, tighten screw. Do not use drill included in kit to tighten screw, as drill torque may damage lens cover.
- Replace battery pack.

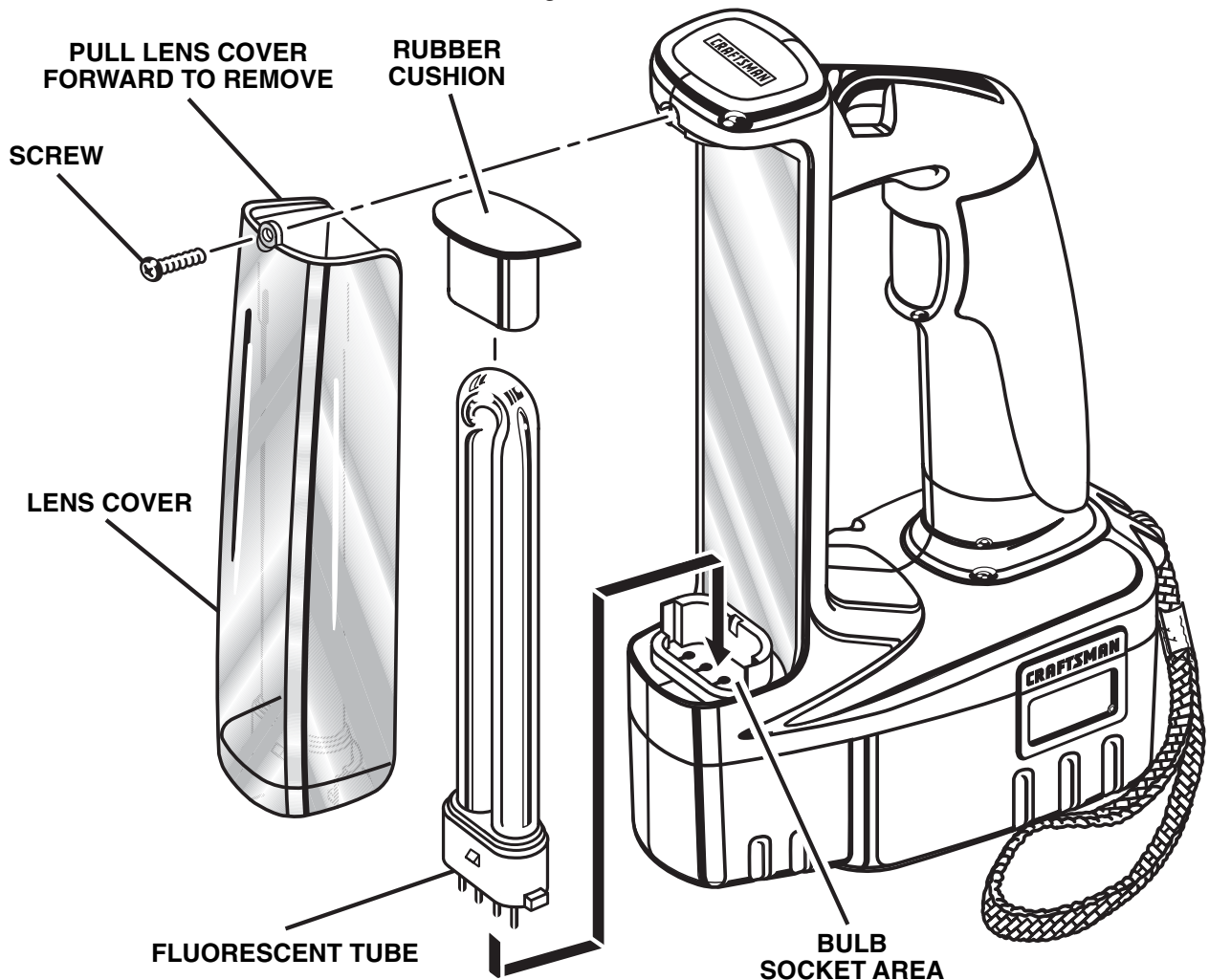

Fig. 5

MAINTENANCE

BATTERIES

The battery pack for this light is equipped with nickel-cadmium rechargeable batteries. Length of service from each charging will depend how much the light is used.

The batteries in the battery pack have been designed to provide maximum trouble free life. However, like all batteries, they will eventually wear out. **Do not** disassemble battery pack and attempt to replace the batteries. Handling of these batteries, especially when wearing rings and jewelry, could result in a serious burn.

To obtain the longest possible battery life, we suggest the following:

- Store and charge the battery pack in a cool area. Temperatures below 50°F or above 100° F will shorten battery life.
- Never store battery pack in a discharged condition. Recharge battery immediately when it becomes discharged.
- All batteries gradually lose their charge. The higher the temperature the quicker they lose their charge. If you store your light for long periods of time without using it, recharge the batteries every month or two. This practice will prolong battery life.



To preserve natural resources, please recycle or dispose of batteries properly.

This product contains nickel-cadmium batteries. Local, state or federal laws may prohibit disposal of nickel-cadmium batteries in ordinary trash.

Consult your local waste authority for information regarding available recycling and/or disposal options.

BATTERY PACK REMOVAL AND PREPARATION FOR RECYCLING

⚠ WARNING: Upon removal, cover the battery pack's terminals with heavy duty adhesive tape. Do not attempt to destroy or disassemble battery pack or remove any of its components. Nickel-cadmium batteries must be recycled or disposed of properly. Also, never touch both terminals with metal objects and/or body parts as short circuit may result. Keep away from children. Failure to comply with these warnings can result in fire and/or serious injury.

⚠ WARNING: Do not attempt to disassemble the battery pack. Fire or injury can result.

Get it fixed, at your home or ours!

Your Home

For repair – **in your home** – of **all** major brand appliances, lawn and garden equipment, or heating and cooling systems, **no matter who made it, no matter who sold it!**

For the replacement parts, accessories and owner's manuals that you need to do-it-yourself.

For Sears professional installation of home appliances and items like garage door openers and water heaters.

1-800-4-MY-HOME® (1-800-469-4663)

Call anytime, day or night (U.S.A. and Canada)

www.sears.com www.sears.ca

Our Home

For repair of carry-in items like vacuums, lawn equipment, and electronics, call or go on-line for the location of your nearest **Sears Parts & Repair Center.**

1-800-488-1222

Call anytime, day or night (U.S.A. only)

www.sears.com

To purchase a protection agreement (U.S.A.) or maintenance agreement (Canada) on a product serviced by Sears:

1-800-827-6655 (U.S.A.)

1-800-361-6665 (Canada)

Para pedir servicio de reparación a domicilio, y para ordenar piezas:

1-888-SU-HOGARSM

(1-888-784-6427)

Au Canada pour service en français:

1-800-LE-FOYER^{MC}

(1-800-533-6937)

www.sears.ca

SEARS

Free Manuals Download Website

<http://myh66.com>

<http://usermanuals.us>

<http://www.somanuals.com>

<http://www.4manuals.cc>

<http://www.manual-lib.com>

<http://www.404manual.com>

<http://www.luxmanual.com>

<http://aubethermostatmanual.com>

Golf course search by state

<http://golfingnear.com>

Email search by domain

<http://emailbydomain.com>

Auto manuals search

<http://auto.somanuals.com>

TV manuals search

<http://tv.somanuals.com>