

Owner's Manual

CRAFTSMAN®

10 in. TABLE SAW

Model No.
315.228110

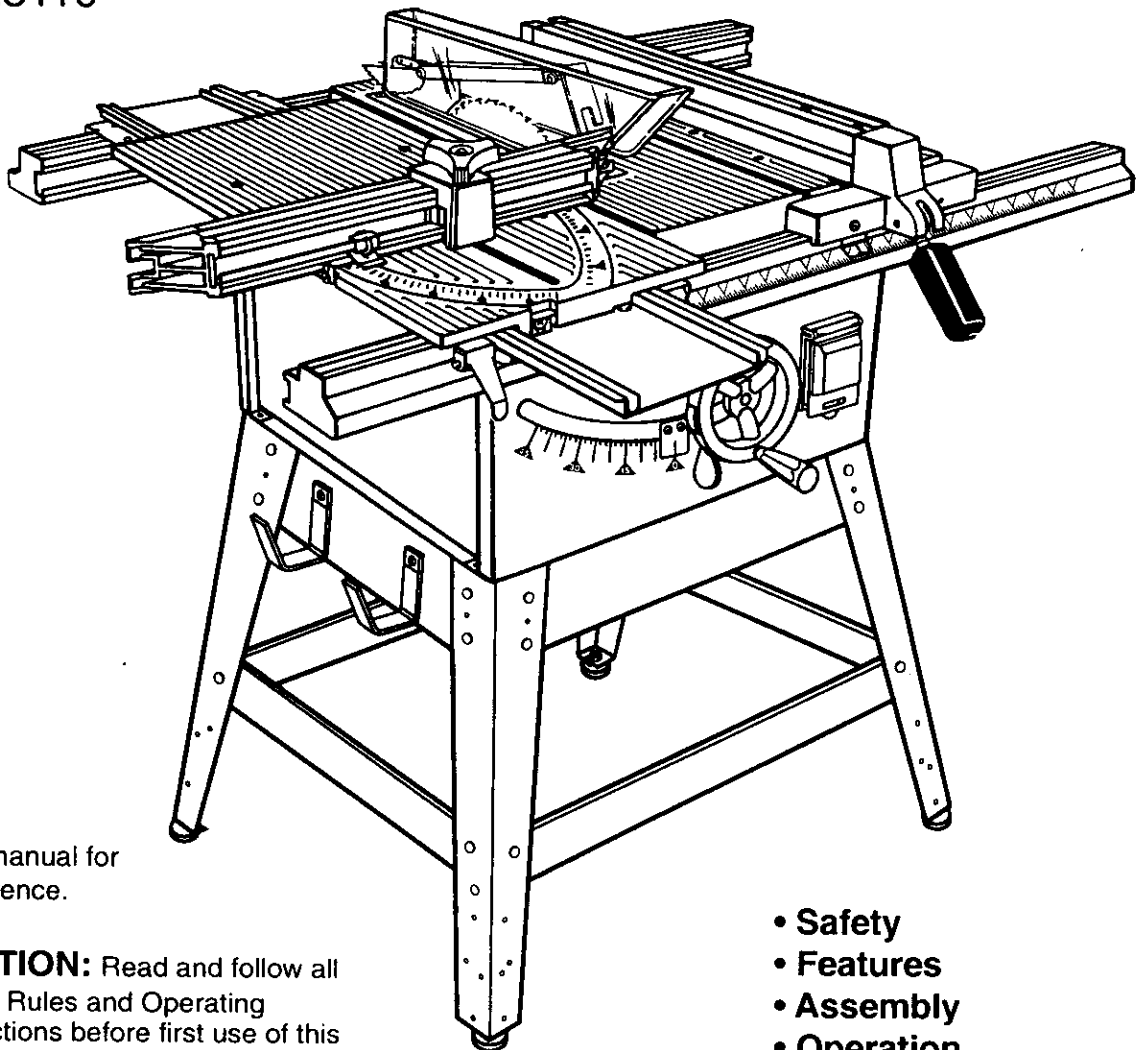

Save this manual for
future reference.

⚠ CAUTION: Read and follow all
Safety Rules and Operating
Instructions before first use of this
product.

Customer Help Line: 1-800-932-3188

Sears, Roebuck and Co., Hoffman Estates, IL 60179 USA
Visit the Craftsman web page: www.sears.com/craftsman

972000-713
1-00

- Safety
- Features
- Assembly
- Operation
- Maintenance
- Parts List



WARRANTY

FULL ONE YEAR WARRANTY ON CRAFTSMAN TABLE SAW

If this **CRAFTSMAN** Table Saw fails due to a defect in material or workmanship within one year from the date of purchase, Sears will repair it, free of charge.

Contact a Sears Service Center for repair.

If this product is used for commercial or rental purposes, this warranty applies only for 90 days from the date of purchase.

This warranty gives you specific legal rights, and you may also have other rights which vary from state to state.

Sears, Roebuck and Co., Dept. 817WA, Hoffman Estates, IL 60179

INTRODUCTION

Your saw has many features for making cutting operations more pleasant and enjoyable. Safety, performance and dependability have been given top priority in the design of this saw making it easy to maintain and operate.

CAUTION: Carefully read through this entire owner's manual before using your new saw. Pay close attention to the Rules For Safe Operation, and all Safety Alert Symbols, including Danger, Warning and Caution. If you use your saw properly and only for what it is intended, you will enjoy years of safe, reliable service.

Look for this symbol to point out important safety precautions. It means attention!!! Your safety is involved.

WARNING:



The operation of any power tool can result in foreign objects being thrown into your eyes, which can result in severe eye damage. Before beginning power tool operation, always wear safety goggles or safety glasses with side shields and a full face shield when needed. We recommend a Wide Vision Safety Mask for use over eyeglasses or standard safety glasses with side shields, available at Sears Retail Stores.

TABLE OF CONTENTS

■ Warranty and Introduction	2
■ Table Of Contents	2-3
■ Rules For Safe Operation	4-6
■ Electrical	7
■ Glossary and Product Specifications	8
■ Unpacking and Accessories	9
■ Loose Parts List	10-11
■ Tools Needed	12
■ Features	13-15
■ Assembly	16-20
A. Assembly Of Leg Stand, Storage Brackets, and Mounting To Saw	16-17
Assembling Leg Stand	16
Assembling Storage Brackets	17
Mounting The Leg Stand On The Table Saw Base	17
B. Assembly Of Rails, Tables, and Fences	18-19
To Install Front and Back Rail	18
To Install Miter Table and Fence	18
To Install Accessory Table and Rip Fence	19

TABLE OF CONTENTS (CONT.)

C. Blade Check and Blade Guard Assembly	19-20
To Check Saw Blade Installation	19
To Install Blade Guard	20
■ Operation	21-33
A. General Information	21
Grounding	21
Types Of Cuts	21-22
Cutting Tips	22
B. Settings and Adjustments	23-28
To Remove The Blade	23
To Check Replace Or Adjust The Riving Knife and Blade Guard Assembly	24
1. Remove The Throat Plate	24
To Reduce The Risk Of Kickback	25
To Avoid Kickback	25
To Make A Push Stick	26
Featherboard	26
How To Make A Featherboard	26
How To Mount A Featherboard	26
To Adjust Blade Depth	27
To Adjust Blade Angle	27
To Set The Scale To The Blade	27
To Lock Miter Table	28
C. Making Cuts	28-33
To Make A Straight Cross Cut	28-29
To Make A Miter Cut	29
To Make A Straight Rip Cut	29
To Make A Bevel Cross Cut	30
To Make A Bevel Rip Cut	30-31
To Make A Compound Miter Cut	31
To Make A Large Panel Cut	31
To Make Non-Through Cuts	32
To Make Dado Cuts	33
■ Maintenance	34-36
A. General Maintenance	34
B. Specific Table Saw Maintenance	34-36
To Set Blade At 0 Or 45 Degrees	34
To Check The Alignment Of The Rip Fence To The Blade	35
To Adjust The Bevel Locking Lever	35
To Align The Miter Locking Clamps	36
To Adjust The Front and Rear Rail Clamps	36
To Adjust The Accessory Table	36
■ Sliding Miter Table Assembly	37-41
Checking Sliding Miter Table Assembly	38
To Check Miter Base Parallelism	38
To Check Miter Fence Alignment	39
Making Adjustments To Sliding Miter Table Assembly	39-41
To Adjust The Miter Base	39
To Adjust The Miter Fence	40
To Adjust Quick Stop	41
■ Lubrication	42
Locker Bracket Assembly	42
Tilt / Elevating Mechanism	42
■ Troubleshooting	44-45
■ Exploded View and Repair Parts List	46-53
■ Parts Ordering / Service	back page

RULES FOR SAFE OPERATION

The purpose of safety symbols is to attract your attention to possible dangers. The safety symbols, and the explanations with them, deserve your careful attention and understanding. The safety warnings do not by themselves eliminate any danger. The instructions or warnings they give are not substitutes for proper accident prevention measures.

SYMBOL MEANING



SAFETY ALERT SYMBOL

Indicates danger, warning, or caution. May be used in conjunction with other symbols or pictographs.



DANGER: Failure to obey a safety warning will result in serious injury to yourself or to others. Always follow the safety precautions to reduce the risk of fire, electric shock and personal injury.



WARNING: Failure to obey a safety warning can result in serious injury to yourself or to others. Always follow the safety precautions to reduce the risk of fire, electric shock and personal injury.



CAUTION: Failure to obey a safety warning may result in property damage or personal injury to yourself or to others. Always follow the safety precautions to reduce the risk of fire, electric shock and personal injury.

Note: Advises you of information or instructions vital to the operation or maintenance of the equipment.

IMPORTANT

Servicing requires extreme care and knowledge of the system and should be performed only by a qualified service technician. For service we suggest you return the tool to your nearest Sears store or repair center. Always use original factory replacement parts when servicing.



WARNING: Do not attempt to operate this tool until you have read thoroughly and understand completely all instructions, safety rules, etc. contained in this manual. Failure to comply can result in accidents involving fire, electrical shock, or serious personal injury. Save the owner's manual and review frequently for continuing safe operation, and instructing others who may use this tool.

READ ALL INSTRUCTIONS

- **KNOW YOUR POWER TOOL.** Read the owner's manual carefully. Learn the saw's applications and limitations as well as the specific potential hazards related to this tool.
- **DO NOT USE IN DANGEROUS ENVIRONMENT.** Do not use power tools near gasoline or other flammable liquids, in damp or wet locations, or expose them to rain. Keep the work area well lit.
- **MAKE WORKSHOP CHILD-PROOF** with padlocks and master switches or by removing starter keys.
- **KEEP CHILDREN AND VISITORS AWAY.** All visitors should wear safety glasses and be kept a safe distance from work area. Do not let visitors contact tool or extension cord while operating.
- **KEEP THE WORK AREA CLEAN.** Cluttered work areas and work benches invite accidents. **DO NOT** leave tools or pieces of wood on the saw while it is in operation.
- **MAINTAIN TOOLS WITH CARE.** Keep tools sharp and clean for better and safer performance. Follow instructions for lubricating and changing accessories.
- **USE THE RIGHT TOOL FOR THE JOB.** Do not force the tool or attachment to do a job it was not designed for. Use it only the way it was intended.
- **DRESS PROPERLY.** Do not wear loose clothing, gloves, neckties, rings, bracelets, or other jewelry. They can get caught and draw you into moving parts. Rubber gloves and nonslip footwear are recommended. Also wear protective hair covering to contain long hair.
- **ALWAYS WEAR SAFETY GLASSES WITH SIDE SHIELDS.** Everyday eyeglasses have only impact-resistant lenses; they are **NOT** safety glasses.
- **NEVER STAND ON TOOL.** Serious injury could occur if the tool is tipped or if the blade is unintentionally contacted.

RULES FOR SAFE OPERATION (Continued)

- **DO NOT OVERREACH.** Keep proper footing and balance at all times.
- **SECURE WORK.** Use clamps or a vise to hold work when practical. It's safer than using your hand and frees both hands to operate tool.
- **USE THE PROPER EXTENSION CORD.** Make sure your extension cord is in good condition. Use only a cord heavy enough to carry the current your product will draw. An undersized cord will cause a drop in line voltage resulting in loss of power and overheating. A wire gage size (A.W.G.) of at least 14 is recommended for an extension cord 25 feet or less in length. If in doubt, use the next heavier gage. The smaller the gage number, the heavier the cord.
- **AVOID ACCIDENTAL STARTING.** Be sure switch is off when plugging in.
- **REMOVE WRENCHES AND ADJUSTING KEYS.** Get in the habit of checking - before turning on tool - that hex keys and adjusting wrenches are removed from tool.
- **CHECK DAMAGED PARTS.** Before using the tool again, check any damaged parts, including guards, for proper operation and performance. Check alignment of moving parts, binding of moving parts, breakage of parts, saw stability, mounting and any other conditions that may affect its operation. A damaged part must be properly repaired or replaced by a qualified service technician at a Sears store or repair center to avoid risk of personal injury.
- **USE ONLY CORRECT BLADES.** Use the right blade size, style and cutting speed for the material and the type of cut. Blade teeth should point down toward the front of the table.
- **USE RECOMMENDED ACCESSORIES.** Using improper accessories may risk injury.
- **USE ONLY SEARS REPLACEMENT PARTS.** All repairs, whether electrical or mechanical, should be made by a qualified service technician at a Sears store or repair center.
- **KEEP GUARDS IN PLACE** and in good working order. This includes the blade guard, riving knife, and anti-kickback pawls.
- **CHECK DIRECTION OF FEED.** Feed work into a blade or cutter against the direction of rotation of the blade or cutter only.
- **DISCONNECT ALL TOOLS.** When not in use, before servicing, or when changing attachments, blades, bits, cutters, etc., all tools should be disconnected from power supply.
- **DO NOT FORCE THE TOOL.** It will do the job better and more safely at the rate for which it was designed.
- **NEVER LEAVE TOOL RUNNING UNATTENDED. TURN THE POWER OFF.** Do not leave tool until it comes to a complete stop.
- **BEFORE DISCONNECTING THE MOTOR;** unplug the saw from power supply.
- ▲ **WARNING:** When servicing, use only identical Craftsman replacement parts. Use of any other parts may create a hazard or cause product damage.
- **NEVER USE THIS TOOL IN AN EXPLOSIVE ATMOSPHERE.** Normal sparking of the motor could ignite fumes.
- **MAKE SURE THE WORK AREA HAS AMPLE LIGHTING** to see the work and that no obstructions will interfere with safe operation **BEFORE** performing any work using this tool.
- **DO NOT USE TOOL IF SWITCH DOES NOT TURN IT ON AND OFF.** Have defective switches replaced by a qualified service technician at a Sears store or repair center.
- **GUARD AGAINST ELECTRICAL SHOCK** by preventing body contact with grounded surfaces such as pipes, radiators, ranges, refrigerator enclosures.
- **GROUND ALL TOOLS.** See Electrical page.
- **WEAR A DUST MASK** to keep from inhaling fine particles.
- **PROTECT YOUR HEARING.** Wear hearing protection during extended periods of operation.
- **DO NOT OPERATE THIS TOOL WHILE UNDER THE INFLUENCE OF DRUGS, ALCOHOL, OR ANY MEDICATION.**
- **STAY ALERT AND EXERCISE CONTROL.** Watch what you are doing and use common sense. **Do not operate tool when you are tired. Do not rush.**
- **AVOID AWKWARD OPERATIONS AND HAND POSITIONS** where a sudden slip could cause your hand to move into the blade. **ALWAYS** make sure you have good balance.
- **ALWAYS SUPPORT LARGE WORK PIECES** while cutting to minimize risk of blade pinching and kickback. Saw may slip, walk or slide while cutting large or heavy boards.

RULES FOR SAFE OPERATION (Continued)

- **GUARD AGAINST KICKBACK.** Kickback can occur when the blade stalls, driving the work piece back toward the operator. It can pull your hand into the blade, resulting in serious personal injury. Stay out of the blade path and turn switch off immediately if blade binds or stalls.
- **USE A SUPPORT FOR THE SIDES AND BACK OF THE SAW TABLE** when sawing wide or long workpieces. Use a sturdy "outrigger" support if a table extension is more than 24 inches long and is attached to the saw, to prevent tipping.
- **CUT ONLY WOOD, PLASTIC OR WOOD-LIKE MATERIALS.** Do not cut metal.
- **NEVER** cut more than one piece at a time. **DO NOT STACK** more than one workpiece on the saw table at a time.
- **DO NOT REMOVE THE SAW'S BLADE GUARDS.** Never operate the saw with any guard or cover removed. Make sure all guards are operating properly before each use.
- **NEVER PERFORM ANY OPERATION FREE-HAND.** Always place the workpiece to be cut on the saw table and position it firmly against the fence as a backstop.
- **USE THE RIP FENCE.** Always use a fence or straight edge guide when ripping.
- **BEFORE MAKING A CUT,** be sure all adjustments are secure.
- **BE SURE THE BLADE PATH IS FREE OF NAILS.** Inspect for and remove all nails from lumber before cutting.
- **BE SURE THE BLADE CLEARS THE WORKPIECE.** Never start the saw with the blade touching the workpiece.
- **KEEP HANDS AWAY FROM CUTTING AREA.** Do not reach underneath work or in blade cutting path with your hands and fingers for any reason. Always turn the power off.
- **USE A PUSH BLOCK OR PUSH STICK** for workpieces so small that your fingers go under the blade guard. **NEVER TOUCH BLADE** or other moving parts during use, for any reason.
- **ALLOW THE MOTOR TO COME UP TO FULL SPEED** before starting a cut to avoid blade binding or stalling.
- **ALWAYS PUSH THE WORKPIECE;** never pull it toward the saw.
- **DO NOT FEED THE MATERIAL TOO QUICKLY.** Do not force the workpiece against the blade.
- **ALWAYS TURN OFF SAW** before disconnecting it, to avoid accidental starting when reconnecting to power supply. **NEVER** leave the table saw unattended while connected to a power source.
- **BEFORE CHANGING THE SETUP, REMOVING COVERS, GUARDS, OR BLADE;** unplug the saw from power supply.
- **KEEP TOOL DRY, CLEAN, AND FREE FROM OIL AND GREASE.** Always use a clean cloth when cleaning. Never use brake fluids, gasoline, petroleum-based products, or any solvents to clean tool.
- **KEEP BLADES CLEAN, SHARP AND WITH SUFFICIENT SET.** Sharp blades minimize stalling and kickback.
- **USE ONLY OUTDOOR EXTENSION CORDS.** Use only extension cords with the marking "Acceptable for use with outdoor appliances; store cords indoors while not in use." Use extension cords with an electrical rating not less than the saw's rating. Always disconnect the extension cord from the outlet before disconnecting the product from the extension cord.
- **INSPECT TOOL CORDS AND EXTENSION CORDS PERIODICALLY** and, if damaged, have repaired by a qualified service technician at a Sears store or repair center. Stay constantly aware of cord location and keep it well away from the moving blade.
- **DO NOT ABUSE CORD.** Never yank cord to disconnect it from receptacle. Keep cord from heat, oil, and sharp edges.
- **SAVE THESE INSTRUCTIONS.** Refer to them frequently and use to instruct other users. If you loan someone this tool, loan them these instructions also.

 **WARNING:** Blade coasts after being turned off.

SAVE THESE INSTRUCTIONS

ELECTRICAL

EXTENSION CORDS

Use only 3-wire extension cords that have 3-prong grounding plugs and 3-pole receptacles that accept the tool's plug. When using a power tool at a considerable distance from the power source, use an extension cord heavy enough to carry the current that the tool will draw. An undersized extension cord will cause a drop in line voltage, resulting in a loss of power and causing the motor to overheat. Use the chart provided below to determine the minimum wire size required in an extension cord. Only round jacketed cords listed by Underwriter's Laboratories (UL) should be used.

Length of Extension Cord	Wire Size (A.W.G.)
Up to 25 feet	14
26-100 feet	12

When working with the tool outdoors, use an extension cord that is designed for outside use. This is indicated by the letters **WA** on the cord's jacket.

Before using an extension cord, inspect it for loose or exposed wires and cut or worn insulation.

⚠ CAUTION: Keep the cord away from the cutting area and position the cord so that it will not be caught on lumber, tools, or other objects during cutting operations.

ELECTRICAL CONNECTION

Your Sears Craftsman Table Saw is powered by a precision built electric motor. It should be connected to a **power supply that is 120 volts, 60 Hz, AC only (normal household current)**. Do not operate this tool on direct current (DC). A substantial voltage drop will cause a loss of power and the motor will overheat. If the saw does not operate when plugged into an outlet, double check the power supply.

SPEED AND WIRING

The no-load speed of your table saw is approximately 4,800 rpm. This speed is not constant and decreases under a load or with lower voltage. For voltage, the wiring in a shop is as important as the motor's horsepower rating. A line intended only for lights cannot properly carry a power tool motor. Wire that is heavy enough for a short distance will be too light for a greater distance. A line that can support one power tool may not be able to support two or three tools.

GROUNDING INSTRUCTIONS

In the event of a malfunction or breakdown, grounding provides a path of least resistance for electric current to reduce the risk of electric shock. This tool is equipped with an electric cord having an equipment-grounding conductor and a grounding plug. The plug must be plugged into a matching outlet that is properly installed and grounded in accordance with all local codes and ordinances.

Do not modify the plug provided. If it will not fit the outlet, have the proper outlet installed by a qualified electrician. Improper connection of the equipment-grounding conductor can result in a risk of electric shock. The conductor with insulation having an outer surface that is green with or without yellow stripes is the equipment-grounding conductor. If repair or replacement of the electric cord or plug is necessary, do not connect the equipment-grounding conductor to a live terminal.

Check with a qualified electrician or service personnel if the grounding instructions are not completely understood, or if in doubt as to whether the tool is properly grounded.

Repair or replace a damaged or worn cord immediately.

This tool is intended for use on a circuit that has an outlet like the one shown in *Figure 1*. It also has a grounding pin like the one shown.

⚠ WARNING: Electrical shock can kill.

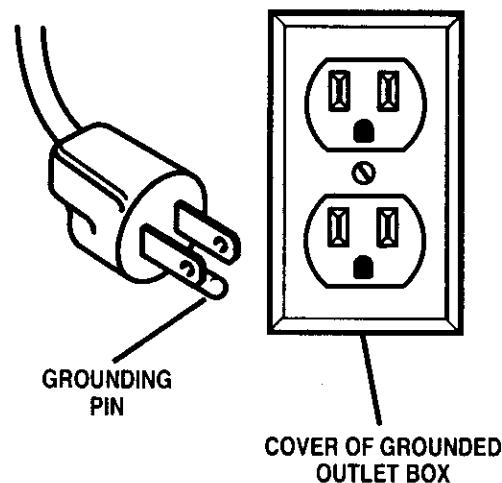

Figure 1

GLOSSARY OF TERMS FOR WOODWORKING

Anti-Kickback Pawls

Toothed safety devices behind the blade designed to stop a workpiece from being kicked back at the operator during a ripping operation.

Arbor

The shaft on which a blade or cutting tool is mounted.

Bevel Cut

A cutting operation made with the blade at any angle other than 90° to the saw table.

Compound Cut

A cut with both a miter angle and a bevel angle.

Crosscut

A cutting operation made across the grain or the width of the workpiece.

Dado

A non-through cut that gives a square notch or trough; requires a special blade.

Featherboard

A device to help guide workpieces during rip cuts.

Freehand (for table saw)

Dangerous practice of making a cut without using rip or miter fences. See Safety Rules.

Gum

A sticky, sap-based residue from wood products.

Heel

Alignment of the blade.

Kerf

The material removed by the blade in a through cut or the slot produced by the blade in a non-through cut.

Kickback

A hazard that can occur when blade binds or stalls, throwing workpiece back toward operator.

Leading End

The end of the workpiece pushed into the cutting tool first.

Miter Cut

A cutting operation made with the miter gage using any angle other than 0° on the miter gage.

Molding

A non-through cut that gives a varied shape to the workpiece and requires a special blade.

Push Stick

A device used to feed the workpiece through the saw to help keep the operator's hands well away from the blade.

Push Block

A device used for non-through cut type operations to help keep the operator's hands away from the blade.

Rabbet

A notch in the edge of a workpiece.

Resaw

A cutting operation to reduce the thickness of the workpiece in order to make thinner pieces.

Resin

A sticky, sap-based substance.

Rip Cut

A cut made with the grain of the workpiece.

Saw Blade Path

The area directly in line with the blade — over, under, behind, or in front of it. Also, the workpiece area which will be or has been cut by the blade.

Set

The distance that the tip of the saw blade tooth is bent (or set) outward from the face of the blade.

Throw-Back

Saw throwing back a workpiece; similar to kickback.

Through Sawing

Any cutting operation where the blade extends completely through the workpiece.

Trailing End

The workpiece end last cut by the blade in a rip cut.

Workpiece

The item on which the cutting operation is being done. The surfaces of a workpiece are commonly referred to as faces, ends, and edges.

Worktable

The surface on which the workpiece rests while performing a cutting operation.

PRODUCT SPECIFICATIONS

Blade Arbor	5/8 in.	Rating	120 V, 60 Hz - AC only
Blade Diameter	10 in.	Input	15 Amperes
Blade Tilt	0° - 45°	No Load Speed	4,800 RPM
Net Weight Without Leg Stand	75 lbs.	Cutting Capacity with Miter at 0°/Bevel 0°:	3-9/16 in.
Net Weight With Leg Stand	97 lbs.	Cutting Capacity with Miter at 0°/Bevel 45°:	2-1/2 in.

UNPACKING

Your new table saw has been designed to give you many years of high quality performance. To insure this goal, proper care and treatment is important. Careful treatment begins with removing all parts from the carton and checking them against the list of loose parts.

Your table saw is shipped complete in one carton and includes a leg stand, two table extensions, a rip fence, a miter fence with adjusting clamp, a blade guard, rails and hardware.

- Separate the saw and all parts from the packing materials and check each against the packing list, especially the small parts that can be hidden in the packing material.

Note: Do not discard the packing materials until you have carefully inspected the saw, identified all parts, and satisfactorily operated your new saw.

If you are missing a part, check the packaging before contacting Sears.

If any parts are missing, do not attempt to assemble your table saw, plug in the power cord, or turn the switch on until the missing parts are obtained and are installed

correctly. Complete parts lists are located at the end of this manual. Use these lists to identify the part number of any missing part. Contact your Sears Service Center or Retail store and get the missing part(s) before assembling and trying to use your saw.

 **WARNING:** Never use gasoline, naphtha, or other highly volatile solvents. Do not ever let brake fluids, gasoline, petroleum-based products, or penetrating oils contact plastic parts. Such chemicals can weaken or destroy plastic.

 **WARNING:** To prevent accidental starting that could cause possible serious personal injury, assemble all parts to your saw before connecting it to power supply. Saw should never be connected to power supply when you are assembling parts, making adjustments, installing or removing blades, or when not in use.

 **WARNING:** If any parts are missing, do not operate this tool until the missing parts are replaced. Failure to do so could result in possible serious personal injury.

ACCESSORIES

The following recommended accessories are currently available at Sears Retail Stores.

Item No. 9-22210	Router Mounting Kit
Item No. 9-22211	Miter Slot Table
Item No. 9-22212	Zero Clearance Throat Plate
Item No. 9-22213	Dado Throat Plate
Item No. 9-22214	Micro-Position Rip-Fence Accessory
Item No. 9-22215	Quick Fold Table
Item No. 9-22216	Wide Table Kit
Item No. 9-22217	Long Miter/Rip Fence
Item No. 9-22218	Air Floatation Table
Item No. 9-22219	Wide Table Leg Set
Item No. 9-22220	Miter Clamp Kit

 **WARNING:** To avoid risk of injury, use recommended dado and zero clearance throat plate when employing a dado accessory.

DO NOT USE 7 in. WOBBLE DADOES

A complete assortment of blades for your saw are available at your nearest Sears Retail Store.

 **WARNING:** The use of attachments or accessories not listed might be hazardous.

LOOSE PARTS LIST

The following items are included with your Table Saw.

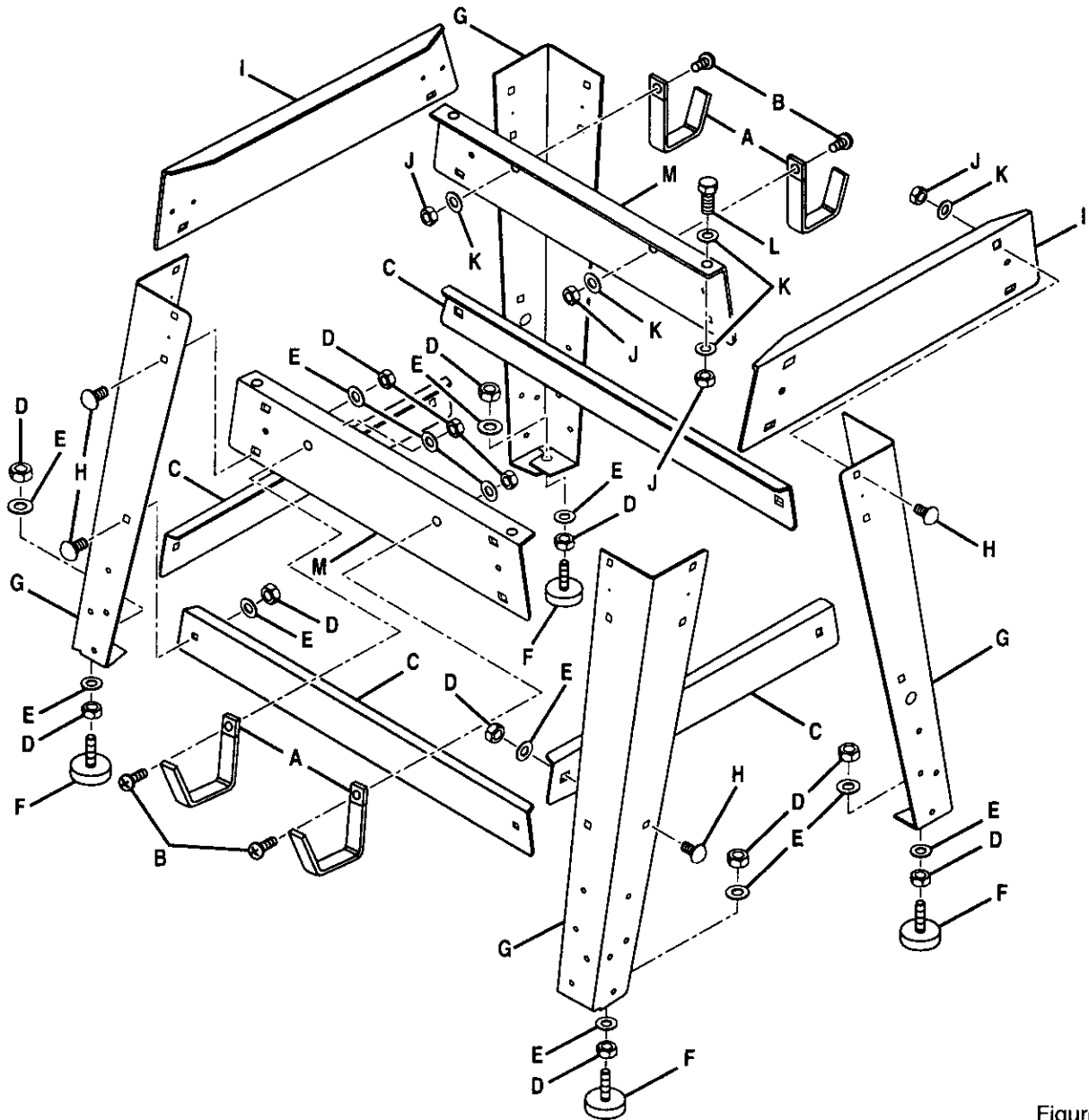

Figure 2

A. Storage Bracket	4	H. Carriage Bolt (5/16-18 x 3/4 in.)	24
B. Screw (1/4-20 x 1/2 in. Pan Hd.)	4	I. Upper Brace	2
C. Lower Brace	4	J. Hex Nut (1/4-20)	8
D. Hex Nut (5/16-18)	32	K. Washer (1/4 in.)	12
E. Washer (5/16 in.)	32	L. Bolt (1/4-20 x 3/4 in. Hex Hd.)	4
F. Leveling Foot	4	M. Upper Side Brace	2
G. Leg	4		

LOOSE PARTS LIST

The following items are included with your Table Saw.

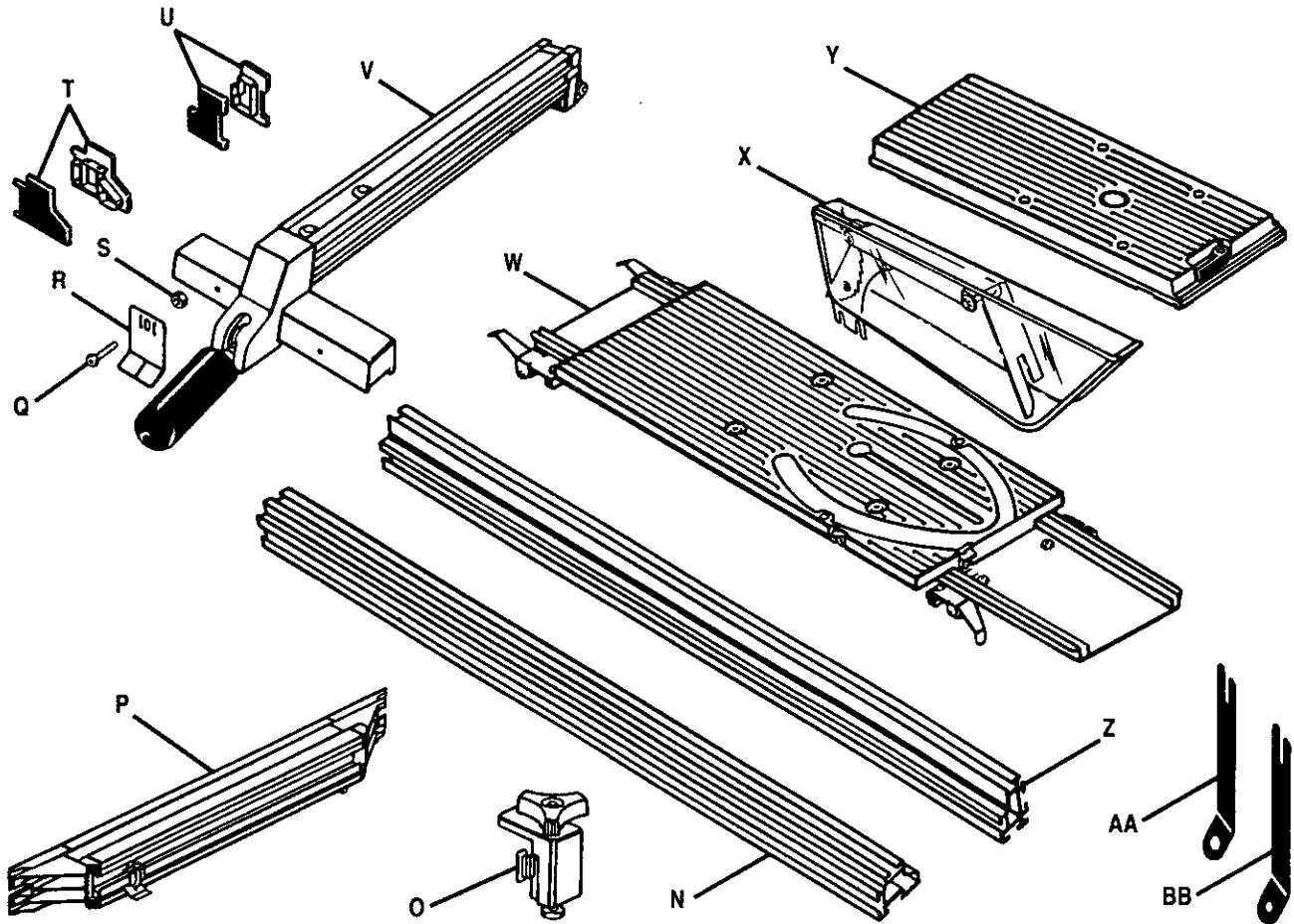

Figure 3

N. Front Rail	1	X. Blade Guard With Riving Knife And Anti-Kickback Pawls	1
O. Miter Fence Holder With Adjusting Clamp	1	Y. Accessory Table	1
P. Miter Fence With Miter Indicator	1	Z. Rear Rail	1
Q. Screw	1	AA. Large wrench	1
R. Rip Scale Indicator	1	BB. Small wrench	1
S. Hex Nut	1	CC. 3/32 in. Hex Key (Not Shown)	1
T. End Plug (Front Rail)	2	DD. 1/8 in. Hex Key (Not Shown)	1
U. End Plug (Rear Rail)	2	EE. 5/32 in. Hex Key (Not Shown)	1
V. Rip Fence	1	FF. 3/16 in. Hex Key (Not Shown)	1
W. Sliding Miter Table	1		

TOOLS NEEDED

The following tools are needed for assembly and alignment. **Note:** The four hex keys listed below have been provided with your saw. The remaining tools are typical shop tools and are not included with your saw.

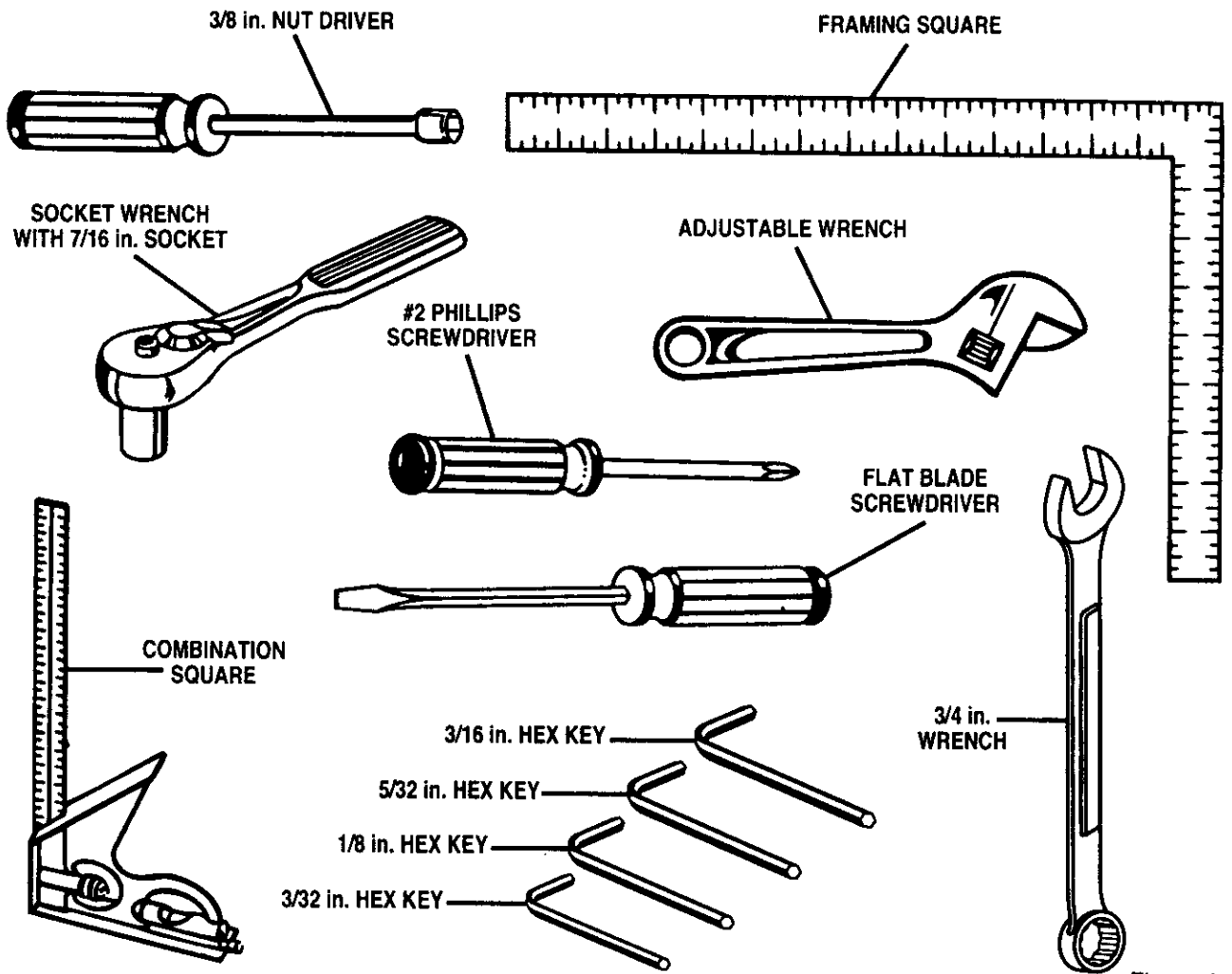

Figure 4

FEATURES

Your saw is designed to perform as a versatile, accurate, precision cutting tool that is easy to operate.

It is equipped with the following features for safety, ease of use, and high-quality performance:

- a carbide tipped combination blade
- a bevel indicator to set the exact angle of the blade, with locking lever
- an adjustable and reversible sliding miter table
- an adjustable miter fence with miter indicator
- an adjustable accessory table
- an adjustable rip fence with scale indicator
- an adjustable riving knife (splitter) and blade guard with anti-kickback pawls
- front and rear guide rails with an easy-to-read scale on front rail
- a dust exhaust (2-1/2 in. hole) that can be adapted to a standard shop vacuum if desired
- blade adjusting handle to set depth of cut
- switch with lockable cover plate to help prevent unauthorized use
- a leg stand

These features provide ease of cutting with all types of wood.

⚠ WARNING: Before attempting to use your saw, familiarize yourself with all operating features and safety requirements.

OPERATING COMPONENTS

The upper portion of the blade projects up through the table, surrounded by an insert called the throat plate. To cut wood at a bevel, the blade must be tilted, using the blade adjustment handle, scale, and bevel indicator found on the front of the cabinet. Inside the cabinet, adjustable positive stops control the degree of movement.

The sliding miter table assembly is used for all cross-cutting operations. The miter fence is easily adjusted to cut wood at an angle by loosening the adjusting clamp, setting the fence to the miter scale, and retightening the clamp. The sliding miter table, which rests on a base mounted on the rails, can be repositioned along the rails for wide work. It can be reversed for ripping so the projecting base is in the back.

Your saw includes a rip fence and an accessory table. The accessory table can be moved from the right side of the saw to the left side as needed. The rip fence is used to position work that will be cut lengthwise. A scale on the front rail shows the distance between the rip fence and the blade.

⚠ CAUTION: The saw blade “coasts” after the saw is turned off.

SPEED AND WIRING

The no-load speed of your table saw is approximately 4,800 rpm. The speed will not remain constant but will be less under a load. The wiring in a shop is as important as the motor's horsepower rating. A line intended for lights only **will not properly carry a power tool motor**. Wire that is heavy enough for a short distance will be too light for a greater distance. A line that can support one power tool may not be able to support two or three tools.

⚠ WARNING: To prevent possible electrical hazards, have a qualified electrician check the line if you are not certain that it is properly wired.

⚠ WARNING: Observe all normal safety precautions related to avoiding electrical shock.

SAFETY DEVICES

Safety devices on your saw include the blade guard, the anti-kickback pawls, and the riving knife (also known as a splitter or spreader). The blade guard is a clear strong plastic shield designed to prevent accidental contact with the blade. It also deflects any flying debris from within.

⚠ WARNING: Although many of the illustrations in this manual are shown with the blade guard removed for clarity, do not operate the saw without the blade guard unless specifically instructed to do so.

The riving knife is a metal device directly behind and above the blade. It is used to help keep the cut wood from binding together and causing possible kickback. It is very important to use the riving knife for all through-sawing operations. The anti-kickback pawls are toothed plates mounted on the riving knife. Their teeth point away from the work in case the work should be pulled back, toward the operator. Then the teeth dig into the wood to help prevent or reduce the possibility of kickback.

Your saw features a receptacle on the right side of the cabinet that permits use of accessories. Use only accessories that are listed for use with this tool. When using a listed accessory, unplug the saw motor cord and use the receptacle and the saw's main power switch to operate the accessory.

FEATURES

KNOW YOUR TABLE SAW

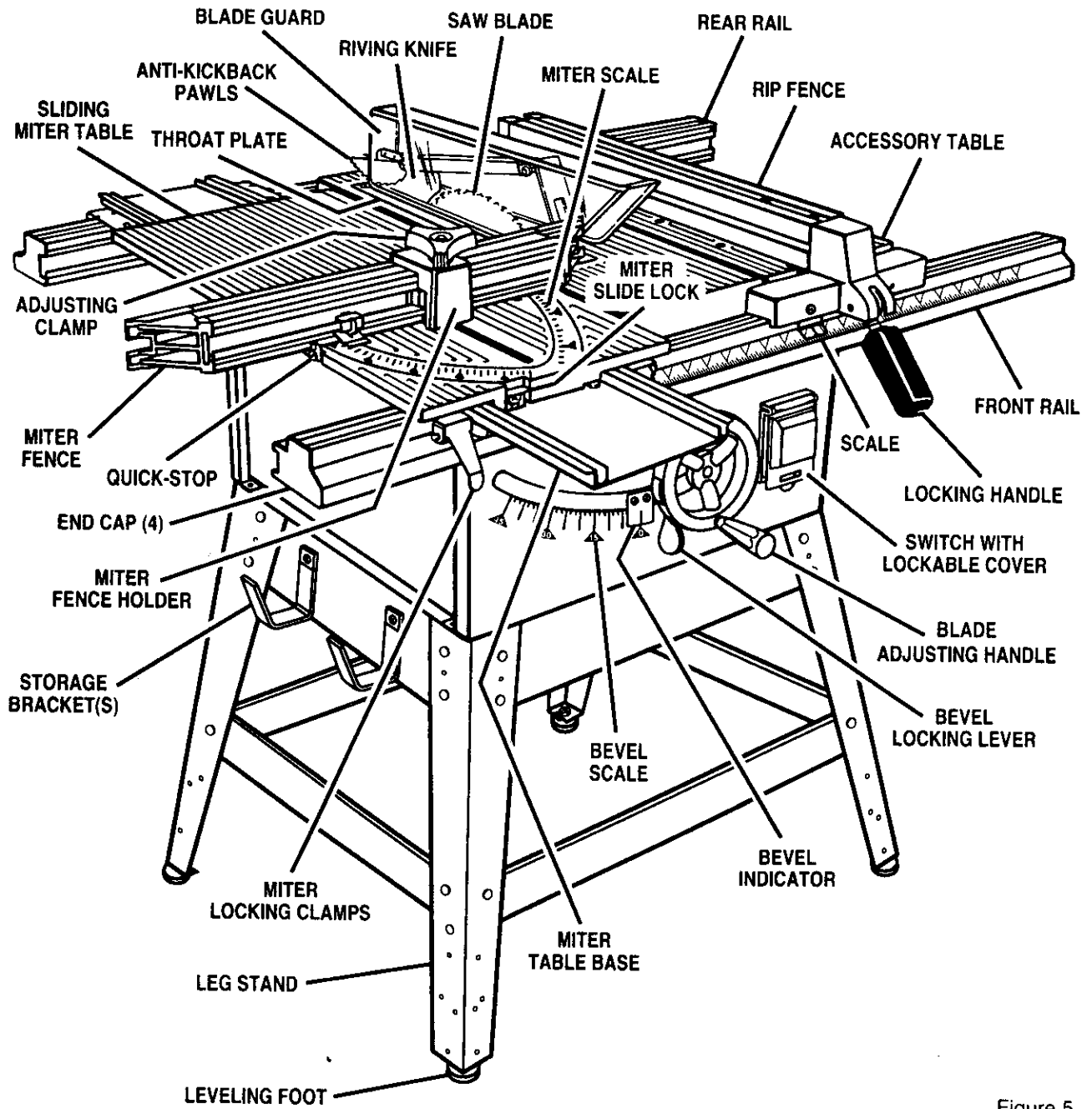

Figure 5

FEATURES

POWER SWITCH

See Figure 6.

Your saw is equipped with a switch that utilizes a lockable switch cover to prevent unauthorized use. With the saw turned **Off**, a padlock can be used to secure the switch cover over the switch. This prevents anyone from starting your saw without removing the padlock, lifting the switch cover, and pressing the switch button.

TO TURN YOUR SAW ON:

- Lift switch cover.
- Press switch button.
- Lower switch cover.

TO TURN YOUR SAW OFF:

- (A) Press or push outside of switch cover, or
- (B) Lift switch cover and press switch button.

TO LOCK YOUR SAW SWITCH:

- Raise switch cover.
- Align metal loop through slot in switch cover while lowering switch cover.
- Place shackle of padlock (not provided) through the metal loop and close padlock.

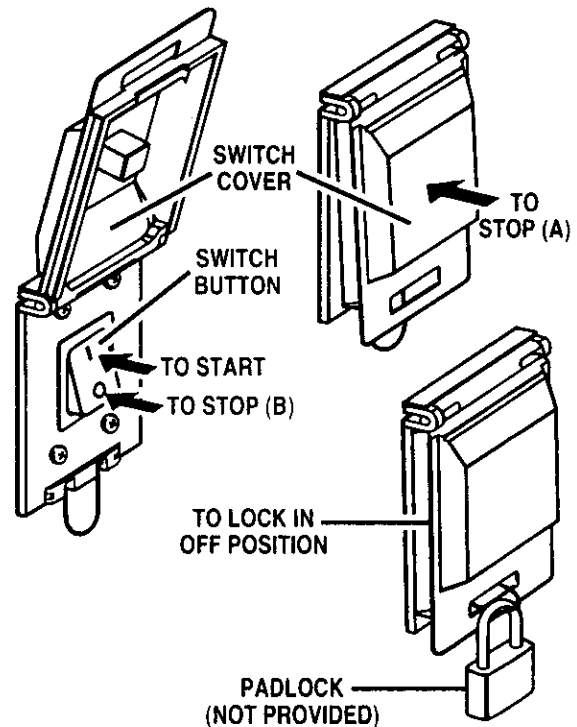

Figure 6

⚠ WARNING: Always make sure your workpiece is not in contact with the blade before operating the switch to start the tool. Failure to heed this warning may cause the workpiece to be kicked back toward the operator and result in serious personal injury.

⚠ WARNING: To reduce the risk of accidental starting, Always make sure the switch is in the **Off** position before plugging tool into the power source.

BLADES

See Figure 7.

For maximum performance, it is recommended that you use the Craftsman 40 tooth, 10 inch carbide tipped combination blade provided with your saw. It is a high-quality carbide tipped combination blade suitable for ripping and crosscut operations. Other recommended blades are listed in the accessory section of this manual.

Check with your nearest Sears Retail Store for other high quality blades as they become available.

⚠ CAUTION: Be sure to use only blades that are rated for at least 5,500 rpm and recommended for use on this saw. Check with your nearest Sears retail store.

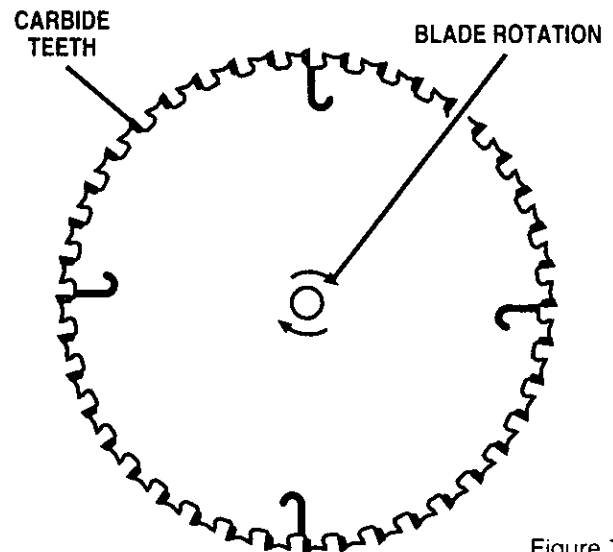

Figure 7

ASSEMBLY

Assembly is best done in the area where the saw will be used. When you remove the table saw base, loose parts, and hardware from the packing materials, check all items with the loose parts list and drawing. If you are unsure about the description of any part, refer to the drawing. If any parts are missing, delay assembling until you have obtained the missing part(s).

A. ASSEMBLY OF LEG STAND, STORAGE BRACKETS, AND MOUNTING TO SAW

ASSEMBLING LEG STAND

See Figures 8 and 9.

- Take the following hardware from the leg stand hardware bag:

- 24 carriage bolts (5/16-18 x 3/4 in.)
- 4 leveling feet
- 32 flat washers (5/16 in.)
- 32 hex nuts (5/16-18)

Note: Remaining hardware from this bag is used for mounting leg stand on the table saw base and mounting storage brackets to upper brace.

- Take 4 legs and 8 braces from loose parts.
- Place an upper side brace inside two of the legs,

with the legs wide end up. (Upper side braces have two large holes in each end.) Make sure the two posts on the leg align with the small holes on the brace.

- Align the two large holes on the brace and the legs. Insert the carriage bolts. Add flat washers and hex nuts and hand tighten. Repeat for the other upper brace. These are the front and back sets.
- For the side sets, install a upper brace on two legs. Add hardware and finger tighten. Repeat for the other upper brace.
- Use the same steps to install the lower braces. Tighten all hex nuts with a 12 mm wrench.
- Place a hex nut and flat washer on each leveling foot. Install the leveling feet from the bottom of

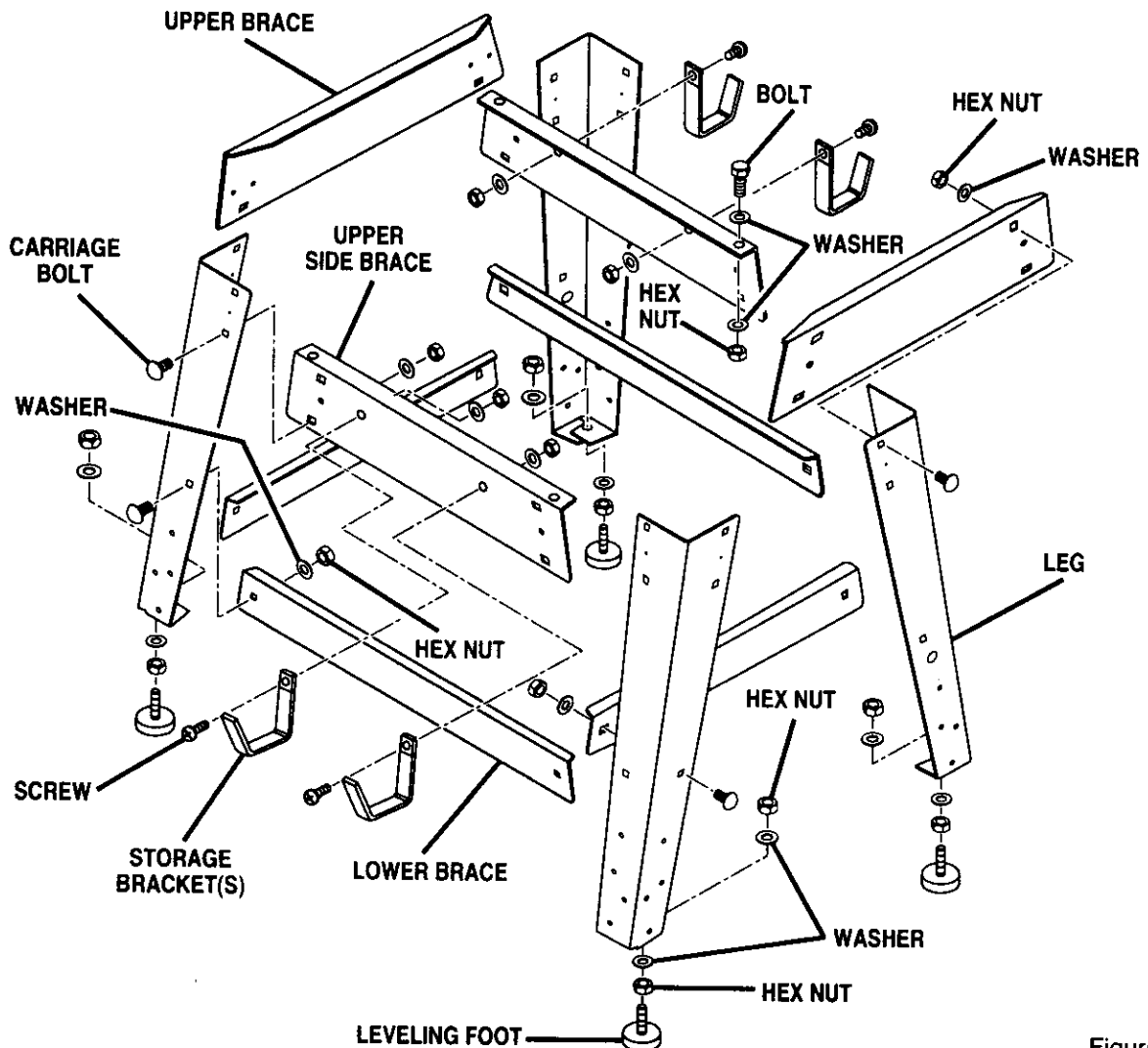

ASSEMBLY

each leg with the bolts pointing up. Cap with the remaining flat washers and hex nuts but do not tighten.

- Move the leg set to desired location. Adjust the leveling feet with a 12 mm wrench, then tighten the top hex nut.

ASSEMBLING STORAGE BRACKETS

See Figure 8.

- Take storage brackets from loose parts.
- Take the following hardware from the leg stand hardware bag:
 - 4 screws (1/4-20 x 1/2 in. Pan Hd.)
 - 4 hex nuts (1/4-20)
 - 4 washers (1/4 in.)

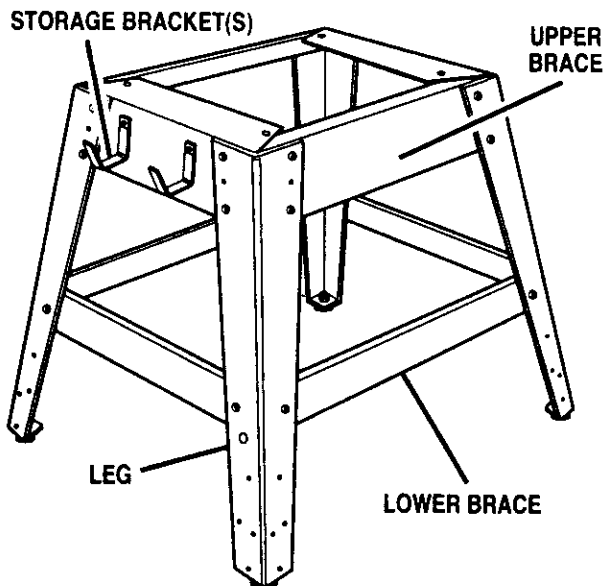

LEG STAND ASSEMBLED Figure 9

- Secure storage brackets to upper braces of leg stand as shown in figures 8 and 9.

Note: If you mount the saw base on a bench instead of the legs, go to the Assembly of Rails, Tables, Fences procedure. The bench surface must have an opening for sawdust to fall through, as large as the opening in the bottom of the saw base. A height of 36 in. from the top of the saw table to the floor is recommended.

MOUNTING THE LEG STAND ON THE TABLE SAW BASE

See Figure 10.

- Take the following from a small hardware bag:
 - 4 hex bolts (1/4-20 x 3/4 in.)
 - 4 hex nuts (1/4-20)
 - 8 flat washers (1/4-20 in.)

Note: This hardware was in the bag with hardware for assembling the leg stand and leveling feet.

- Place the saw table upside down on a smooth surface, such as cardboard, on the floor.

WARNING: Do not lift the saw without help. The saw base weighs approximately 75 lbs. Hold it close to your body. Keep your knees bent and lift with your legs, not your back. Ignoring these precautions can result in back injury.

- Place the leg stand on the table saw base. Align the holes in the table with the holes in the end braces.
- Place a flat washer on a bolt and insert through hole. Add a flat washer and a hex nut. Hand tighten. See Figure 10.
- Repeat for three remaining holes. Tighten all hardware with a 12 mm wrench. You may find it helpful to use one wrench to hold the head of the bolt and one to tighten the hex nut.

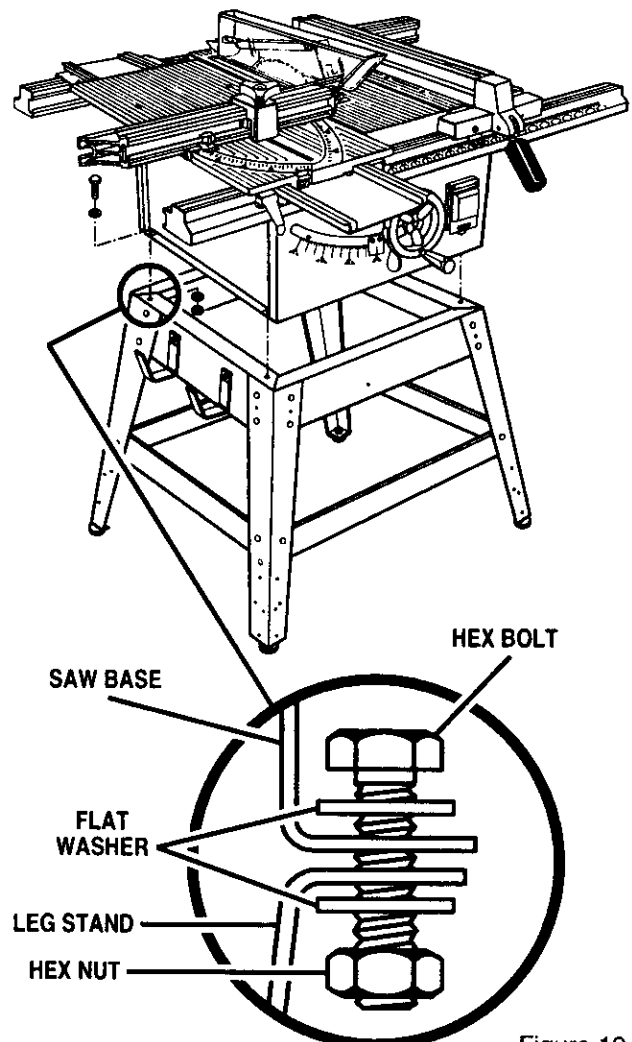

Figure 10

ASSEMBLY

⚠ WARNING: Do not connect to power supply until assembly is complete. Failure to comply could result in accidental starting and possible serious injury.

B. ASSEMBLY OF RAILS, TABLES, AND FENCES

TO INSTALL FRONT AND BACK RAILS

- Position end caps on both rails and secure in place by tapping with a block of wood or a rubber mallet.
- Loosen the front rail clamps one-half (1/2) turn from the tightened position. Loosen the square rail holder nut one-fourth (1/4) turn to allow the front rail to slide over it. *See Figures 11 and 12.*
- Mount the front rail with the scale facing the outside toward the operator.
- Check to make sure the rail clamps will securely clamp the rail before sliding the entire assembly into position. If not, repeat steps 2 and 3 above.
- Slide the rail into position over both clamps and secure.
- Mount the rear rail, following the same clamping procedure as shown for the front rail. Orient the rear rail as shown in figure 12.

TO INSTALL MITER TABLE AND FENCE

- Install the sliding miter table assembly over the front and rear rails. *See Figure 13.* Check that it slides easily on the rails. Push both front miter locking clamps down evenly on each side to secure. Repeat for both rear miter locking clamps. **Note:** Do not force miter locking clamps fully down. Tighten only to flat "seated" position.
- To install the miter fence holder to the miter fence, loosen the attachment bolt by turning the adjusting clamp (the knob on top) counterclockwise. Make sure the adjusting clamp is loose enough so the bolt has enough clearance to slide in the table slot. Slide the tabs into the grooves in the miter fence. *See Figure 14.*
- Mount the miter fence to the miter table by installing the locator pin (below the miter fence) into hole "A" or "B". (Hole "A" is closest to the blade). At the same time, place the attachment bolt in the slot. Secure the adjusting clamp, but do not tighten. **Note:** Hole "A" should be used for short pieces of wood and hole "B" should be used for long pieces of wood.
- Adjust the miter indicator to the scale.
- Retighten the adjusting clamp.

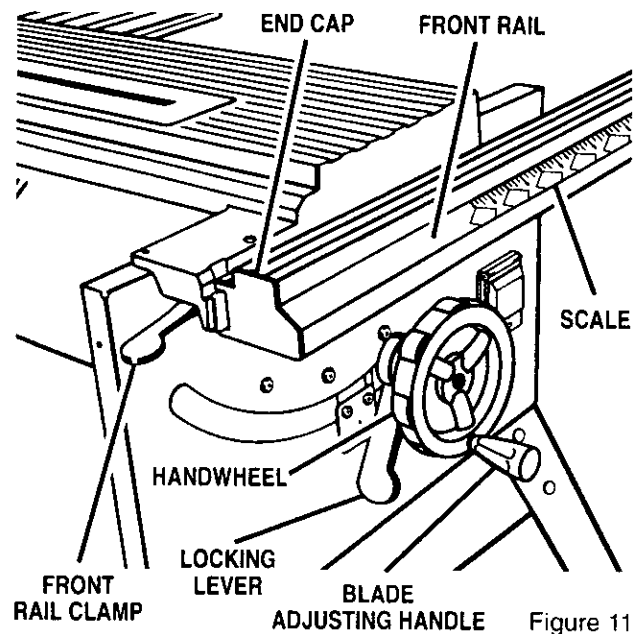

Figure 11

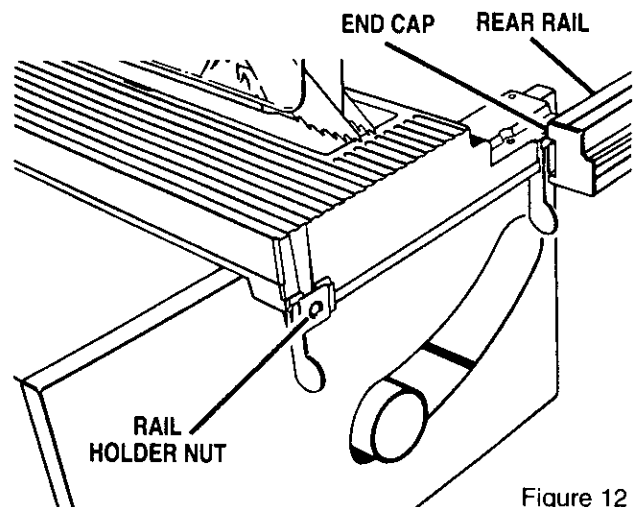

Figure 12

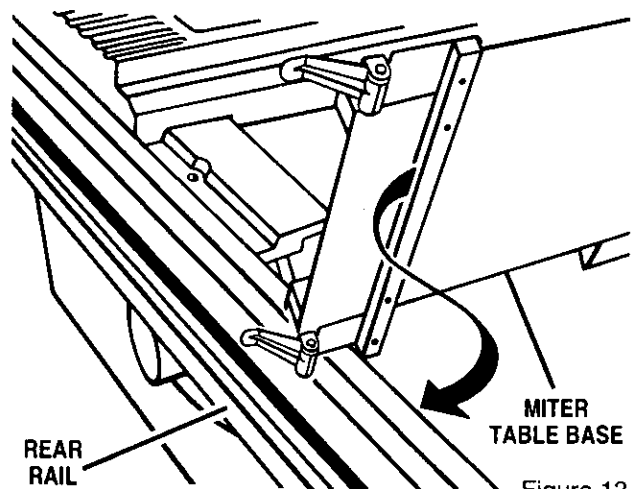

Figure 13

ASSEMBLY

TO INSTALL ACCESSORY TABLE AND RIP FENCE

- Place the accessory table on the front and rear rails, fitting the lip into the rear rail. Position the slot on the underside of the accessory table onto the front rail and tighten the lever securely. See Figure 15.
- Screw the locking handle into the rip fence mounting hole. See Figure 16.
- Remove the scale indicator assembly from the plastic bag and install on either side of the fence. The pan head screw (#8-32 x 1/2 in.) goes on the outside of the front block. The scale indicator and hex nut (#8-32) go immediately behind the front lip of the front block.
- To install the rip fence, place the rear lip on the rear rail and pull slightly toward the front of the unit. Lower front end onto the guide surfaces on top of the front rail. Check for a smooth gliding action. Swing the locking handle down to automatically align and secure the fence. When securely locked, the locking handle should point downward.

⚠ WARNING: Do not connect to power supply until assembly is complete. Failure to comply could result in accidental starting and possible serious injury.

C. BLADE CHECK AND BLADE GUARD ASSEMBLY

TO CHECK SAW BLADE INSTALLATION

- To check the saw blade, first remove the three screws holding the throat plate in place. Remove the throat plate. See Figure 17.
- Make sure the bevel locking lever is securely pushed to the left. Raise the blade arbor to its full height by turning the blade adjusting handle clockwise.
- Using the smaller hex wrench, insert the flat open end into the arbor shaft as shown in figure 18. Insert the larger hex wrench over the hex nut, and, holding both wrenches firmly, pull the larger wrench forward to the front of the machine to loosen and push to tighten. Make sure the blade nut is securely tightened. Do not overtighten.

Note: Arbor shaft has left hand threads.

- Check all clearances for free blade rotation.
- See **To Set the Scale to the Blade** in the Operation Section. In cutting operations, the scale will be set to the side of the blade where the cut will be measured and made.

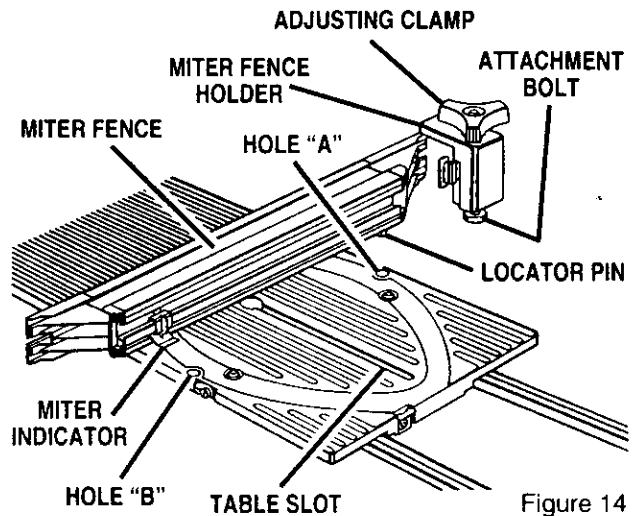

Figure 14

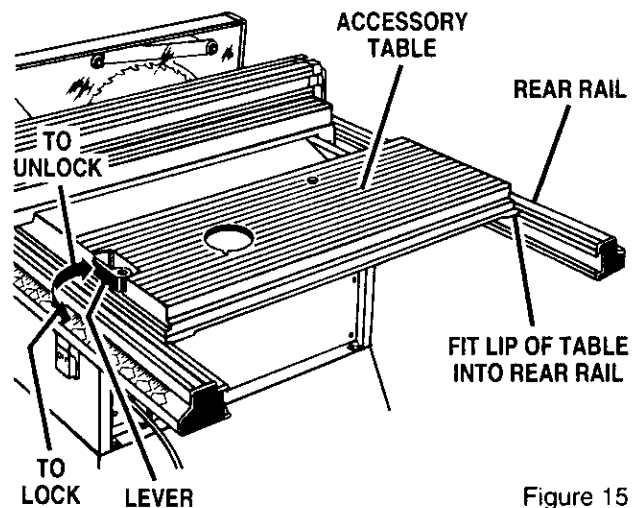

Figure 15

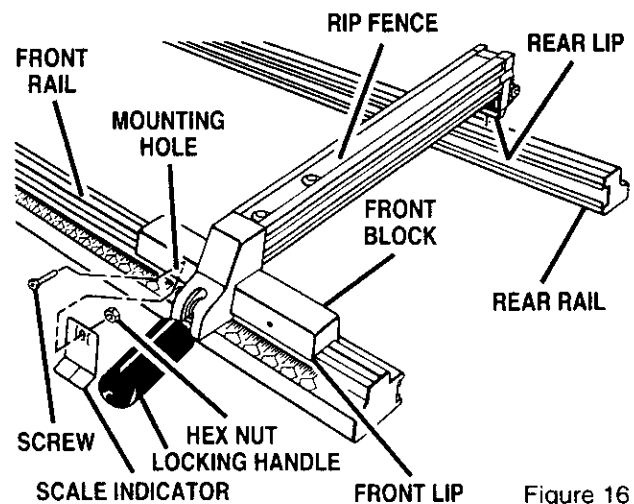
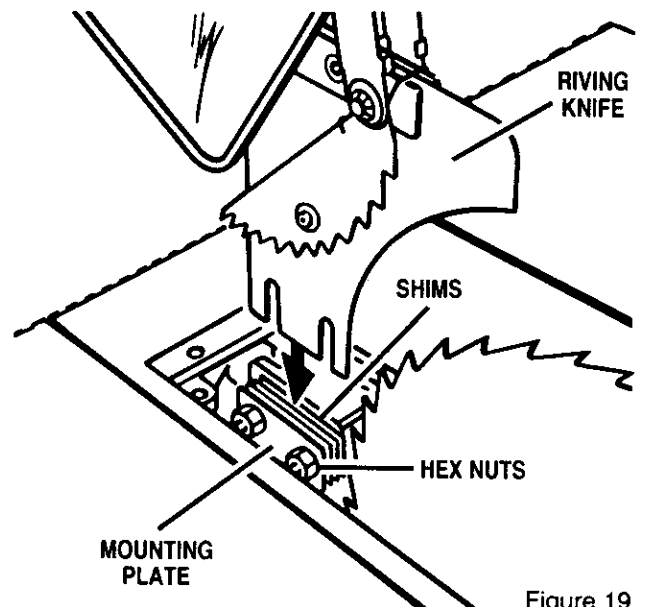
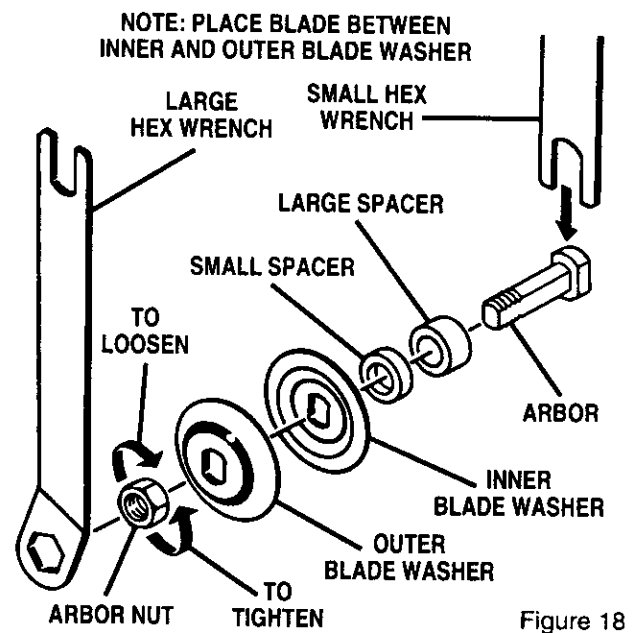
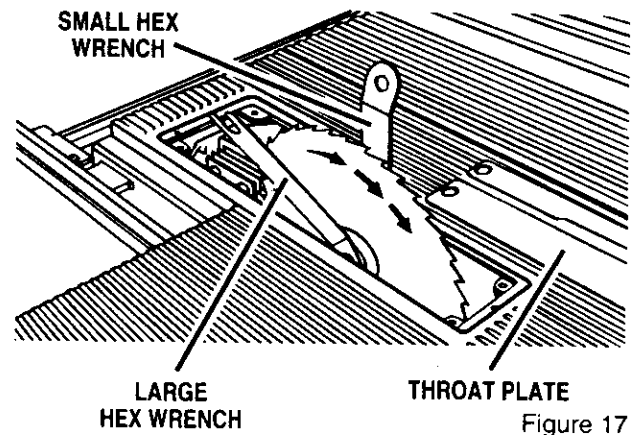

Figure 16

ASSEMBLY

TO INSTALL BLADE GUARD

- To install the blade guard, first remove the three screws holding the throat plate in place. Remove the throat plate. *See Figure 17.*
- Make sure that the locking lever is securely pushed to the left. Raise the blade arbor to its full height by turning the blade adjusting handle clockwise.
- Move the locking lever to the right for Angle mode. Slowly turn the blade adjustment handle to put the blade at 30 degrees. The handle will "pop out" slightly as it engages the clutch.
- Holding the blade adjusting handle with one hand, use the other hand to push the locking lever firmly to the left to lock the angle.
- Using the small hex wrench, install the blade guard by loosening the two attachment hex nuts enough to slide the riving knife down between the shims. **Do not remove the hex nuts.** *See Figure 19.* Partially retighten the two attachment nuts. Check the blade and riving knife alignment.
- Correctly align the blade and riving knife as shown, repeating step 5 as needed. Tighten attachment nuts securely. If riving knife is not positioned correctly, with blade up, it could contact saw table when blade is lowered and restrict blade elevation.
- Blade alignment with the riving knife can be adjusted for different blade widths. Refer to **Settings and Adjustments** in the Operations Section.
- Check the blade guard assembly for clearances and free movement. Reinstall the throat plate into the opening, lower the blade and secure the three attachment screws. Tighten the screws securely.



OPERATION

A. GENERAL INFORMATION

GROUNDING

Your saw's three-prong plug must be plugged into a matching outlet that is properly installed and grounded in accordance with all local codes and ordinances.

Improper connection of the equipment can result in electric shock. Check with an electrician or service personnel if you are unsure about proper grounding. Do not modify the plug; if it will not fit the outlet, have the correct outlet installed by a qualified electrician.

To temporarily use the saw with a two-prong outlet, use an adapter, provided the outlet is properly grounded. Make sure the extending green wire is connected to the outlet-plate retaining screw. The temporary adapter should be used only until a properly grounded outlet can be installed by a qualified electrician, and only if ordinances permit such use.

⚠ WARNING: If an extension cord is used, make sure it has a three-prong plug and is large enough to prevent excessive voltage loss.

⚠ WARNING: The saw's motor cord must only be plugged into the receptacle provided on the saw which is controlled by the saw's master switch. Never plug the motor cord directly into an extension cord as this will prevent the ability to switch the saw off.

TYPES OF CUTS

There are six basic types of cuts: the straight cross cut, the miter cut, the rip cut, the bevel cross cut, the bevel rip cut, and the bevel miter cut (compound miter cut). All other cuts are of these basic six. Operating procedures for making each kind of cut are given later in this section.

⚠ WARNING: Always make sure the blade guard and anti-kickback pawls are in place and working properly when making these cuts to avoid possible injury.

Cross cuts are straight, 90 degree cuts made across the grain of the workpiece. The wood is fed into the cut at a 90 degree angle to the blade and the blade is vertical. *See Figure 22.*

Miter cuts are made with the wood at any angle other than 90 degrees. *See Figure 23.* (The wood is angled to the blade.) Miter cuts may tend to "creep" away from the miter fence during cutting. This can be controlled by holding the workpiece securely against the miter fence. The miter clamp kit has been designed and tested for this purpose.

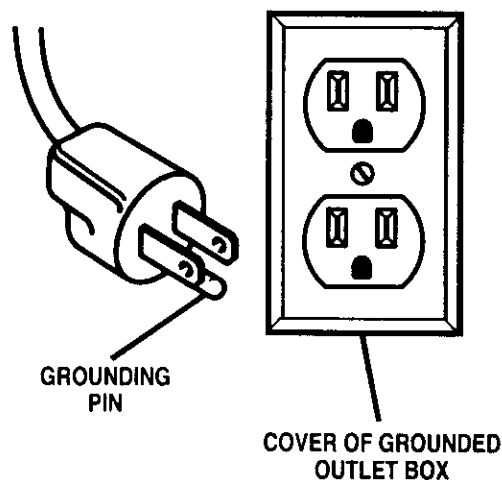

Figure 20

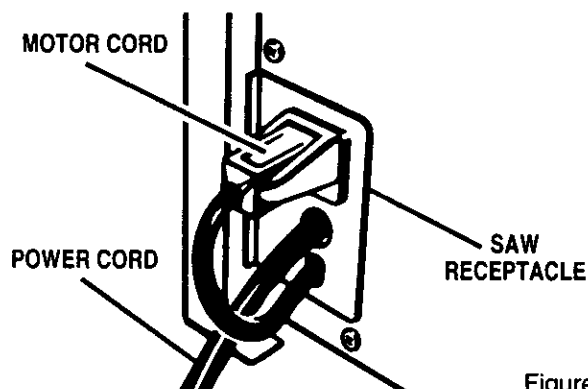

Figure 21

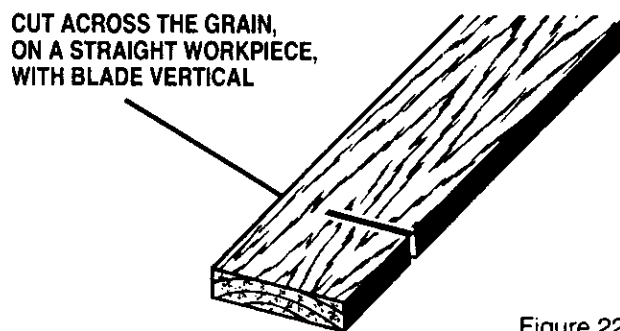

Figure 22

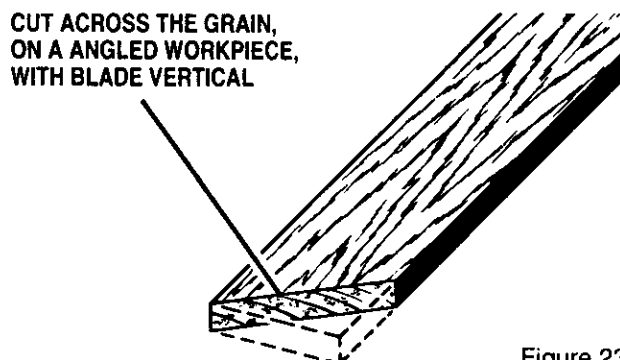

Figure 23

OPERATION

Rip cuts are made with the grain of the wood. See Figure 24. To help control kickback while making a rip cut, keep the anti-kickback pawls properly maintained and adjusted, make sure one side of the wood rides firmly against the fence, and **always** use a push stick with small or narrow pieces of wood.

Note: Push sticks should also be used to finish a cut when ripping long narrow pieces of wood, to prevent your hands from getting close to the blade. See Figure 34.

Bevel cross cuts are made with an angled blade, cutting wood across the grain.

Bevel rip cuts are made with an angled blade, cutting wood with the grain. See Figure 25.

Note: The fence must always be on the left side of the blade when making bevel cuts. See Figure 45.

Compound or bevel miter cuts are made with an angled blade on wood that is angled to the blade. Be thoroughly familiar with making straight cross cuts, bevel cross cuts, and miter cuts before trying a compound miter cut. See Figure 26.

CUTTING TIPS

Dado and rabbet cuts are non-through cuts which can be either rip cuts or cross cuts. Carefully read and understand all sections of this owner's manual before attempting any operation.

⚠ WARNING: All blades and dado sets must be rated for at least 5,500 RPM to prevent possible injury.

- The kerf (the cut made by the blade in the wood) will be wider than the blade to avoid overheating or binding. Make allowance for the kerf when measuring wood.
- Make sure the kerf is made on the waste side of the measuring line.
- Cut the wood with the finish side up.
- Knock out any loose knots with a hammer before making the cut.
- Always provide proper support for the wood as it comes out of the saw.
- See the Accessories Section in this manual for a list of recommended blades.

CUT WITH THE GRAIN,
ON A STRAIGHT WORKPIECE
WITH BLADE VERTICAL

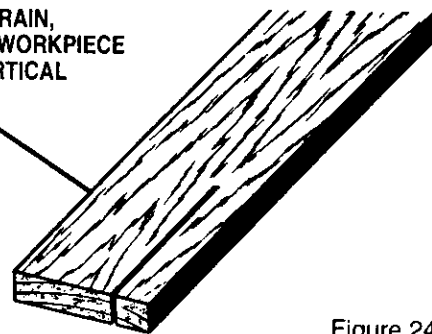
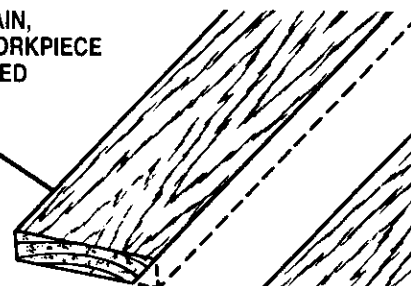

Figure 24

CUT WITH THE GRAIN,
ON A STRAIGHT WORKPIECE
WITH BLADE ANGLED



CUT ACROSS THE GRAIN,
ON A STRAIGHT WORKPIECE
WITH BLADE ANGLED

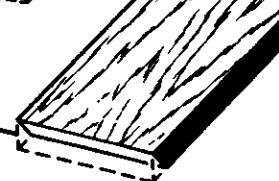

Figure 25

CUT WITH AN ANGLED
BLADE AND WORKPIECE
ANGLED TO THE BLADE

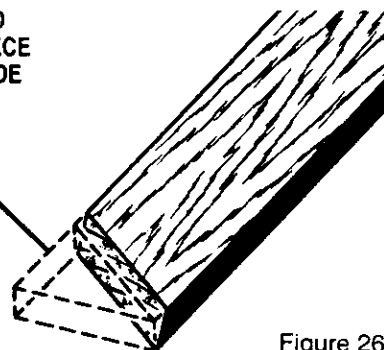

Figure 26

OPERATION

B. SETTINGS AND ADJUSTMENTS

TO REMOVE THE BLADE

Use the two wrenches supplied with the saw for this procedure.

⚠ WARNING: Unplug your saw and make sure the blade guard assembly is installed and working properly to avoid serious personal injury.

- Raise the blade guard. See figure 27, overview of saw.
- Remove the three screws from the throat plate and lift the throat plate out of the slot.
- Push the bevel locking lever to the left for elevation mode.
- Raise the blade to its full height by turning the blade adjusting handle clockwise.
- Place the open end of the small hex wrench into the slot beside the blade. The wrench will fit over two flats on the arbor (blade shaft). See Figure 28.
- Fit the large hex wrench onto the arbor nut. Turn clockwise and remove the nut, taking care not to drag your knuckles across the blade.

Note: The arbor nut has left-hand threads.

- Remove the outer blade washer from the arbor and then remove the blade. Make sure that inner blade washer and both spacers are tight against arbor shoulder.
- Replace with a new blade. Make sure the blade teeth are pointing forward, toward incoming work.
- Put the outer blade washer and arbor nut back on, aligning with the flats on the arbor. Tighten the nut with a counterclockwise turn.

Note: Use care not to cross thread arbor nut. Do not overtighten.

- Rotate the blade by hand to make sure it is turning freely.
- Check the riving knife and adjust if needed (See next procedure).
- Insert the throat plate, lower the blade, then secure the throat plate with the three throat plate screws. Tighten the screws firmly.
- Push bevel locking lever to the left to allow blade elevation and lowering.

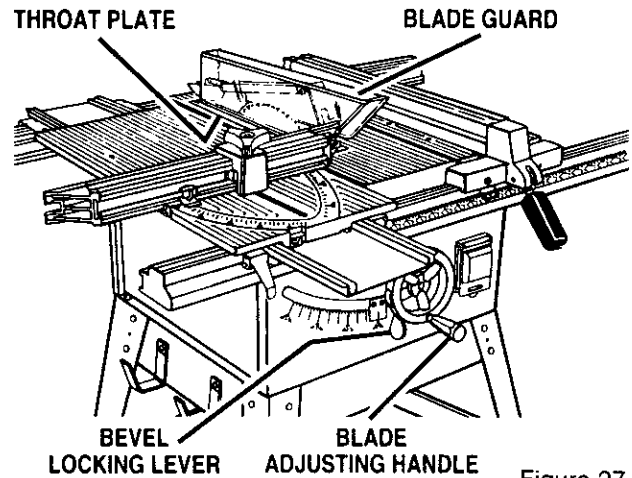

Figure 27

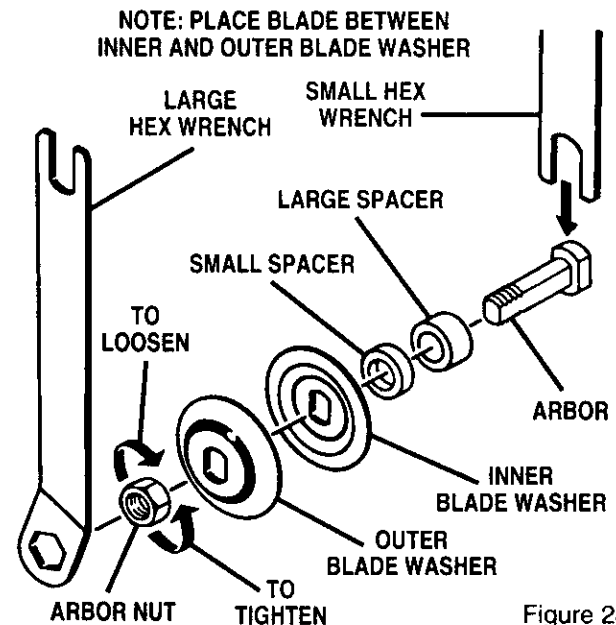

Figure 28

TO ANGLE BLADE, PUSH BEVEL LOCKING LEVER RIGHT.
 TO LOWER BLADE, PUSH BEVEL LOCKING LEVER LEFT AND ROTATE BLADE ADJUSTING HANDLE COUNTERCLOCKWISE

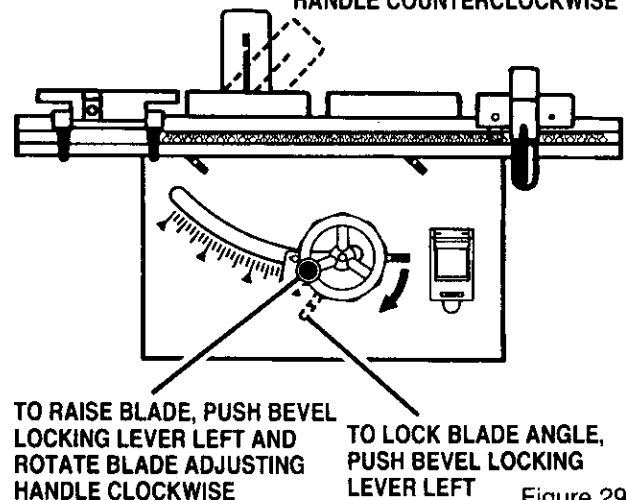

Figure 29

OPERATION

TO CHECK, REPLACE OR ADJUST THE RIVING KNIFE AND BLADE GUARD ASSEMBLY

The riving knife is mounted between several shims that can be relocated as needed to center the knife behind the blade. It is held in place by two bolts and hex nuts at its base. The bolts are set in slots that permit front-to-back adjustment.

⚠ WARNING: Unplug the saw before working on it. If the saw is not unplugged, accidental start-up may occur, resulting in possible serious injury.

REMOVE THE THROAT PLATE.

- With blade guard up, make sure the riving knife is placed at least 1/8 inch from the outer points of the blade. See Figure 31. Then make sure it is centered within the width of the blade. See Figure 32. If either placement is wrong, adjust with the following steps.
- Raise the saw blade by pushing the bevel locking lever to the left and rotating the blade adjustment handle clockwise.
- Put the saw in Angle mode by moving the bevel locking lever to the right. Slowly turn the blade adjusting handle until the bevel indicator is at a 30 degree angle. Lock the angle by holding the blade adjusting handle with one hand and returning the bevel locking lever to the left with the other.
- With the box end of the small hex wrench, loosen the two nuts at the base of the riving knife. **Do not remove nuts.** Remove the riving knife/guard assembly.
- Rearrange the riving knife between the shims to achieve the correct centering.

⚠ WARNING: Properly align riving knife. Improperly aligned riving knife may cause blade to bind which will increase risk of kickback.

- Adjust the bolts front-to-back as needed to place the riving knife approximately 1/8 inch from the blade's outer points. Tighten with the small hex wrench to secure the riving knife and blade guard assembly.
- Bring the blade back to the desired angle and height. Insert the throat plate, lower the blade, and secure the throat plate with the three throat plate screws. Tighten the screws firmly.

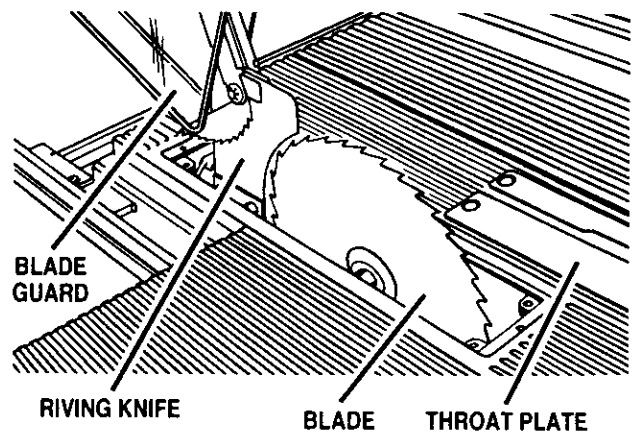

Figure 30

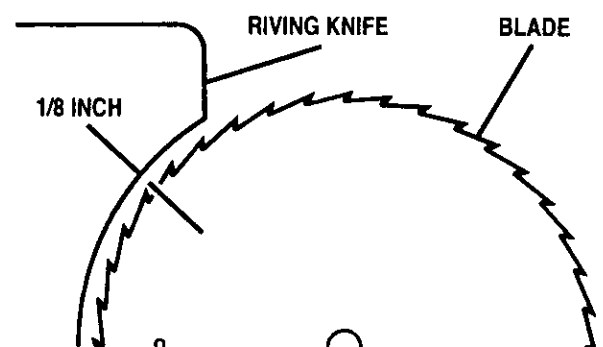

Figure 31

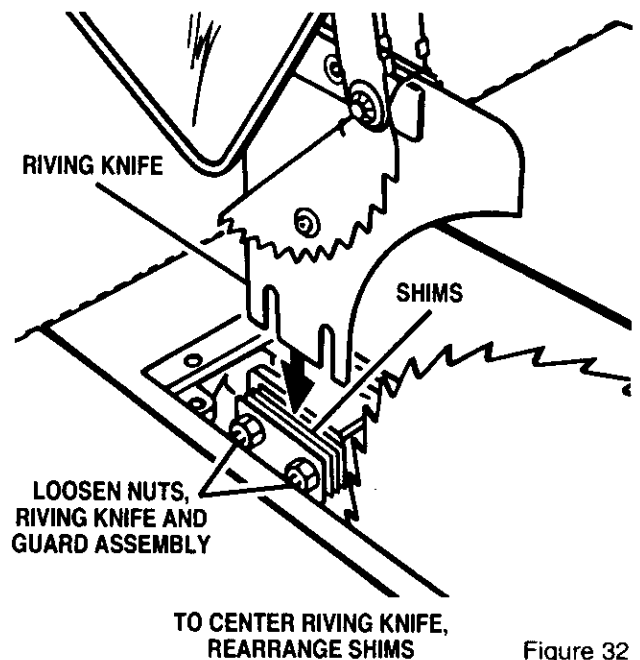

Figure 32

OPERATION

TO REDUCE RISK OF KICKBACK

Kickback can occur when the blade stalls or binds, kicking the workpiece back toward you with great force and speed. If your hands are near the saw blade, they may be jerked loose and thrown into the blade. Obviously, kickback can cause serious injury, and it is well worth using precautions to avoid the risks.

Kickback can be caused by any action that pinches the blade in the wood, such as the following:

- making a cut with incorrect blade depth
- sawing into knots or nails in the workpiece
- twisting the wood while making a cut
- making a cut with a dull, gummed-up, or improperly set blade
- failing to support work
- forcing a cut
- cutting warped or wet lumber
- misusing the saw
- not following correct operating procedures
- failing to use the anti-kickback pawls
- using the wrong blade for the type of cut

TO AVOID KICKBACK

Use these guidelines to avoid kickback:

- Always use the correct blade depth setting. The top point of the blade teeth should clear the workpiece, 1/8 inch to 1/4 inch.
- Inspect the work for knots or nails before beginning a cut. Knock out any loose knots with a hammer. Never saw into a loose knot or nail.
- Make straight cuts. Always use the rip fence when rip cutting. This helps prevent twisting the wood in the cut.
- Always use clean, sharp, and properly-set blades. Never make cuts with dull blades.
- To avoid pinching the blade, support the work properly before beginning a cut.
- When making a cut, use steady, even pressure. Never force cuts.
- Do not cut wet or warped lumber.
- Always hold your workpiece firmly with both hands or use push blocks, push sticks, and featherboards to keep your body in a balanced position to be able to resist kickback should it occur. Use featherboards and push sticks to control non-through cuts on small workpieces.

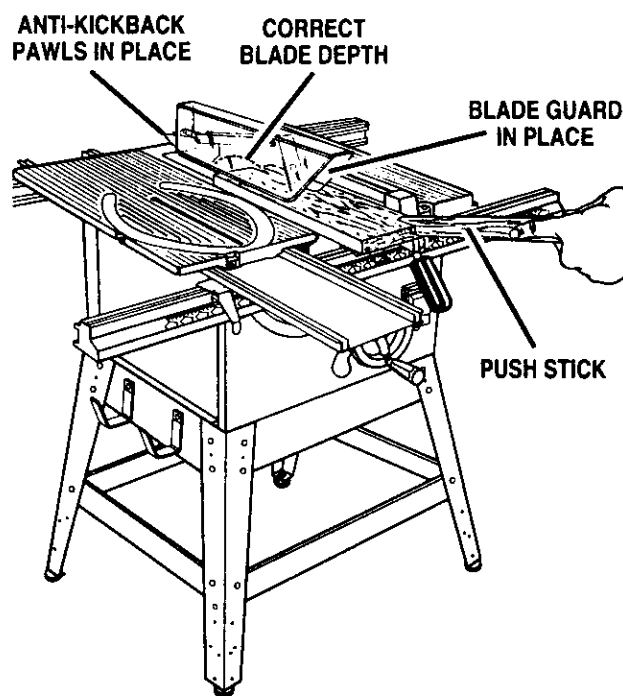

**NO KNOTS, NAILS OR WARPS IN WOOD,
WOOD FED AND SUPPORTED CORRECTLY**

Figure 33

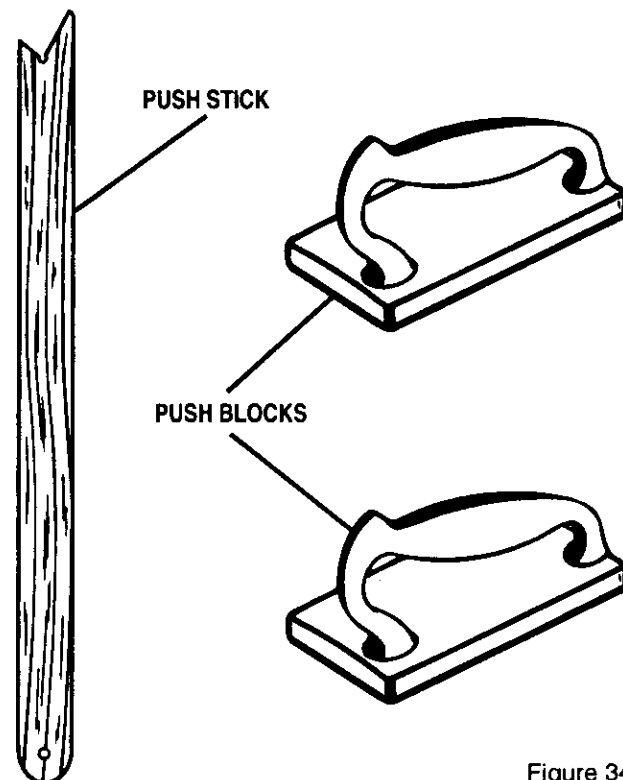

Figure 34

OPERATION

⚠ WARNING: Never stand directly in line with the blade or allow hands to come closer than 3 inches to the blade. Do not reach over or across the blade. Failure to comply can result in serious personal injury.

■ Use the right type of blade for the cut being made.

TO MAKE A PUSH STICK

A push stick is a device used to safely push a workpiece through the blade instead of using your hands. Push sticks in various sizes and shapes can be made from scrap wood. The stick must always be narrower than the workpiece. If it is too wide, it may jam on the rip fence or blade. When ripping narrow stock, always use a push stick so your hand does not come close to the saw blade.

Note: Push blocks and featherboards should always be used when making non-through cuts.

A simple push stick design is shown in figure 34. Remember that the stick must always be narrower than the workpiece to avoid risk of injury.

FEATHERBOARD

A featherboard is a device used to help control the workpiece by guiding it securely against the table or fence. Featherboards are especially useful when ripping small workpieces and for completing non-through cuts. Featherboards are made from a solid piece of straight grain wood, free from splits or knots.

HOW TO MAKE A FEATHERBOARD

The featherboard is an excellent project for your saw. Select a solid piece of lumber approximately 3/4 in. thick, 3-5/8 in. wide and 18 inches long. Mark the center of the width on one end of the stock. Miter one-half of the width to 30° and miter the other half of the same end to 45°. See page 29 for information

on miter cuts. Mark the board from the point at 6 in., 8 in., 10 in. and 12 in. Drill a 3/8 in. hole at the 8 in., 10 in., and 12 in. marks as indicated in figure 35. Prepare the saw for ripping as discussed on page 29. Set the rip fence to allow approximately a 1/4 in. "finger" to be cut in the stock. Feed the stock only to the mark previously made at 6 inches. Turn the saw **Off** and allow the blade to completely stop rotating before removing the stock. Reset the rip fence and cut spaced rips into the workpiece to allow approximately 1/4 in. fingers and 1/8 in. spaces between the fingers. See Figure 35.

HOW TO MOUNT A FEATHERBOARD

Remove the adjusting clamp knob, bolt and washer from the Miter Fence Holder. Place the bolt through one of the holes in the featherboard. Positioning the featherboard will depend on the placement of the bolt and the position of the sliding miter table on the rails. Place the washer on the bolt and attach the adjusting clamp knob, loosely. Position the featherboard with the hex head of the bolt in the miter table slot but do not tighten. Completely lower the saw blade. Position the rip fence to the desired adjustment for the cut to be performed and lock. Place the workpiece against the fence and over the saw blade area. Adjust the featherboard to apply resistance to the workpiece just forward of the blade. Securely tighten the adjusting clamp knob to secure the featherboard in place. Attach a C-clamp to further secure the featherboard to the edge of the Sliding Miter Table.

⚠ WARNING: Do not locate the featherboard to the rear of the workpiece. Kickback can result from the featherboard pinching the workpiece and binding the blade in the saw kerf if positioned improperly. Failure to heed this warning can result in serious personal injury.

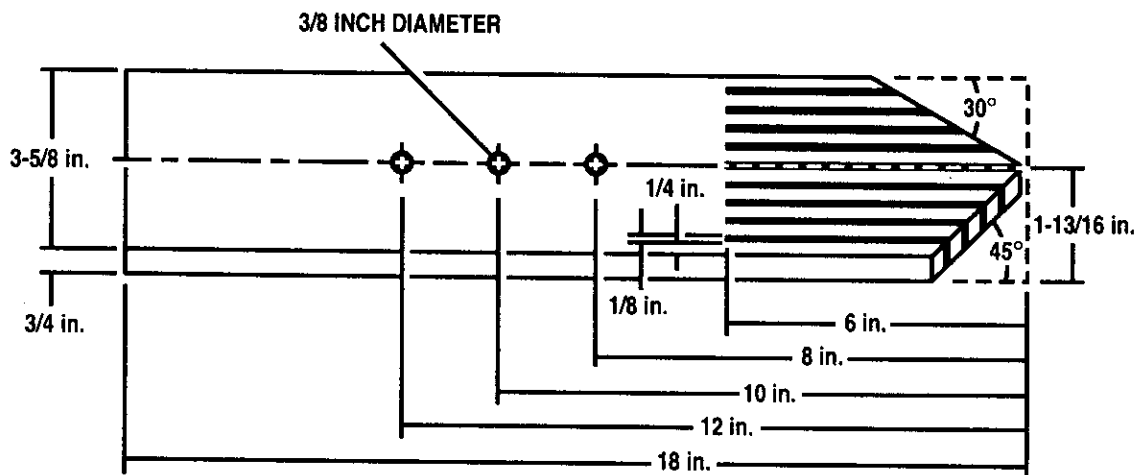

Figure 35

OPERATION

TO ADJUST THE BLADE DEPTH

The blade depth should be set so that the outer points of the blade are higher than the workpiece by approximately 1/8 in. to 1/4 in. but the lowest points (gullets) are below the top surface. See Figure 36.

- ⚠ **WARNING:** Unplug the saw and make sure the blade guard assembly is installed and working properly to avoid serious personal injury.
- Push the bevel locking lever to the left for elevation mode.
- Raise the blade by turning the blade adjusting handle clockwise or lower it by turning the handle counterclockwise.

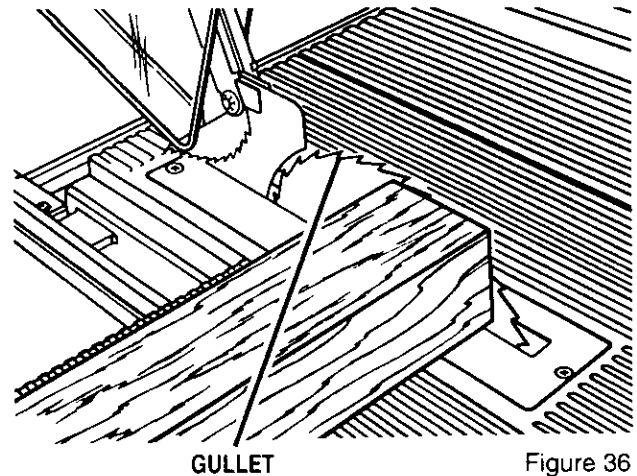

Figure 36

TO ADJUST THE BLADE ANGLE

See Figure 37.

- ⚠ **WARNING:** Unplug the saw and make sure the blade guard assembly is installed and working properly to avoid serious personal injury.
- Push the bevel locking lever to the right for angle mode.
- Angle the blade by turning the blade adjusting handle until the bevel indicator shows the correct angle.
- Return the bevel locking lever securely to the left to lock the angle, while holding the blade adjusting handle in place.

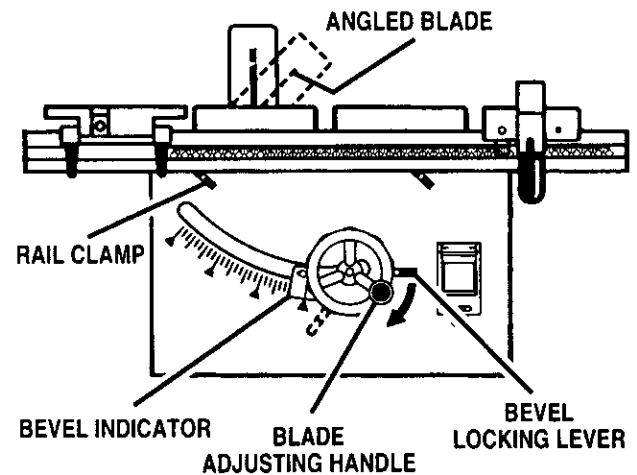

Figure 37

TO SET THE SCALE TO THE BLADE

The scale is usable from 0-24 in. to the right side of the blade and 0-21 in. on the left side of the blade. The operator can select any desired dimension within those ranges. Use the following steps to set the scale to the blade and scale indicator. Begin with the blade at a zero angle (straight up). See Figure 38.

- Loosen the rip fence by raising the locking handle.
- Using a framing square, set the rip fence 2 in. from the blade tip edge.
- Loosen both front and rear rails by lifting the front and rear rail clamps. See Figure 37.
- Adjust the front rail until the 2 in. mark is placed at the scale indicator. Align the rear rail to the front rail.
- Tighten the rails and check the dimension and the rip fence in both directions.

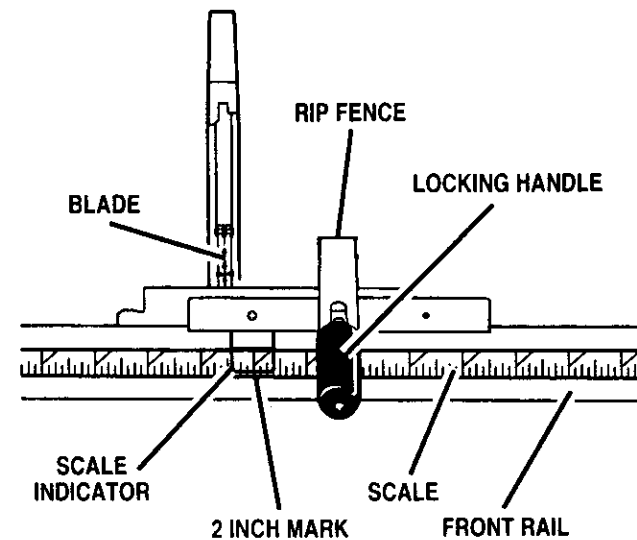

Figure 38

OPERATION

TO LOCK MITER TABLE

See Figure 39.

The miter table slides to let the operator slide the workpiece across the saw. A miter slide lock is mounted on the front of the miter table to lock it in place. The miter slide lock is placed in a slot on the base to align the miter table with the front edge of the saw table. The sliding miter table should be locked for any cut in which the operator prefers a fixed table.

- To lock the miter table with the base projecting to the front, place miter slide lock in the back slot on the base.
- To lock the miter table with the base projecting to the back, place miter slide lock in the front slot on the base.

C. MAKING CUTS

The blade provided with your saw is a high-quality carbide tipped combination blade suitable for ripping and crosscut operations. Check with your Sears Retail Store for other recommended blades.

⚠ WARNING: All blades must be rated for at least 5,500 RPM to prevent possible injury.

TO MAKE A STRAIGHT CROSS CUT

See Figure 40.

It is recommended you make test cuts on scrap wood.

⚠ WARNING: Never use rip fence as cutoff gauge when crosscutting.

⚠ WARNING: Make sure the blade guard assembly is installed and working properly to avoid serious personal injury.

- Remove the rip fence by lifting the locking handle.
- Set the blade to the correct depth for the workpiece.
- Set the miter fence to 90 degrees with the quick-stop or the miter scale.
- Make sure the miter fence won't touch the blade while feeding the wood. Make a trial pass of the miter table. The miter fence should not contact the blade. Loosen the adjusting clamp to move the fence if needed.
- Place a support (the same height as saw table) behind the saw for the cut work. See Quick Fold Table in Accessories on page 9.
- Make sure the wood is clear of the blade before turning on the saw.
- To turn saw **On**, lift switch cover and press switch button. Then lower switch cover.

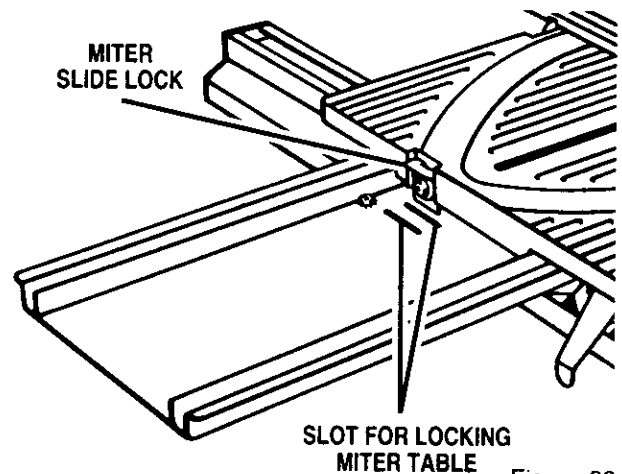

Figure 39

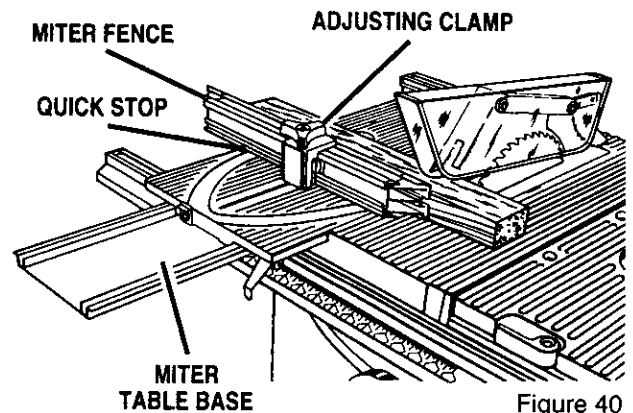

Figure 40

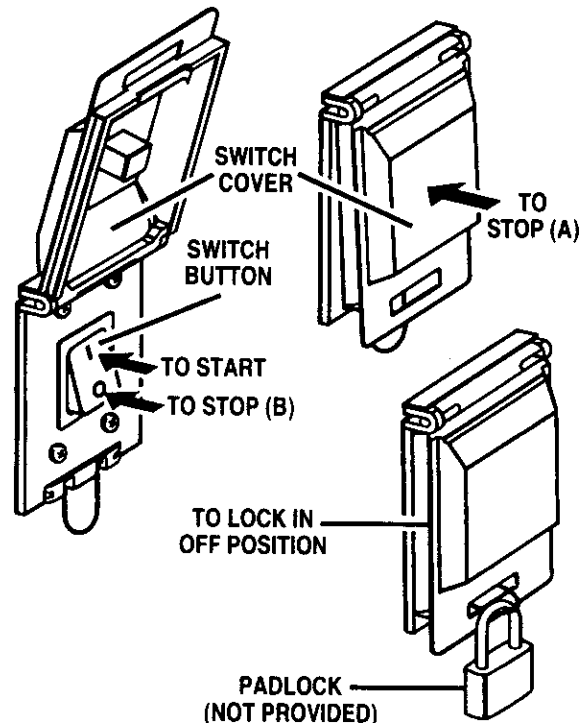

Figure 41

OPERATION

- To turn saw **Off**, (A) press or push outside of switch cover, or (B) lift switch cover and press switch button. See Figure 41.

Note: To prevent unauthorized use, lock your saw in the **Off** position with a padlock as shown in figure 41.

- Let the blade build up to full speed before moving the miter table to feed the workpiece into the blade.
- Hold the work firmly against the miter fence with both hands and push the miter table to feed the work into the blade.

TO MAKE A MITER CUT

See Figure 42.

It is recommended you make test cuts on scrap wood.

⚠ WARNING: Make sure the blade guard assembly is installed and working properly to avoid serious personal injury.

- Remove the rip fence by lifting the locking handle.
- Loosen the adjusting clamp to set the desired angle of the miter fence. Place the miter indicator on the miter fence to the desired angle on the miter table. Retighten the clamp.
- Place a support (the same height as saw table) behind the saw for the cut work. See Quick Fold Table in Accessories on page 9.
- Make sure the miter fence will not contact the blade while feeding the wood. Make a trial pass of the miter table. The miter fence should not contact the blade. Loosen the adjusting clamp to move it away from the blade if needed.
- Make sure the wood is clear of the blade before turning on the saw.
- Let the blade build up to full speed before moving the miter table to feed the workpiece into the blade.
- Hold the work firmly against the miter fence with both hands, keeping well clear of the blade, and push the miter table to feed the work into the blade.

TO MAKE A STRAIGHT RIP CUT

See Figure 43.

It is recommended you make a test cut on scrap wood.

⚠ WARNING: Make sure the blade guard assembly is installed and working properly to avoid serious personal injury.

- Remove the miter fence. Position accessory table and sliding miter table to provide the support necessary for the cut being performed. Securely lock the rip fence with the locking handle.

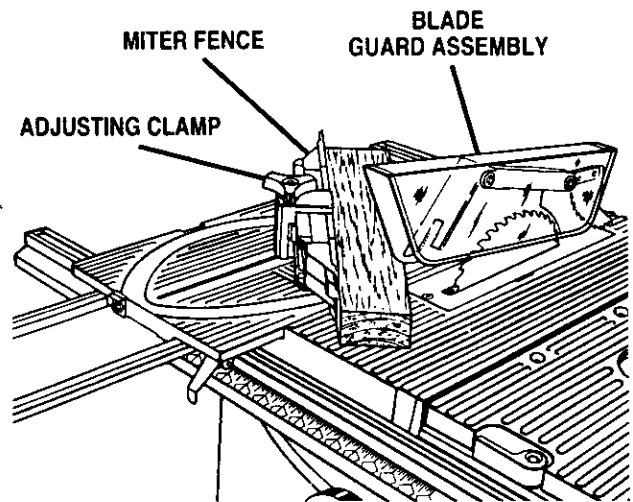

Figure 42

- Don't leave one side of saw unsupported.
- Position the rip fence the desired distance from the blade for the cut and securely lock the handle. Adjust the scale to zero at the cutting edge of the blade.
- Place a support (the same height as saw table) behind the saw for the cut work. See Quick Fold Table in Accessories on page 9.
- Use a push block or push stick to move the wood through the cut past the blade. **Never push a small piece of wood into the blade with your hand, always use a push stick.** The use of push blocks, push sticks, and featherboards are necessary when making non-through cuts.
- Stand to the side of the wood as it contacts the blade to reduce the chance of injury should kickback occur. **Never stand directly in the line of cut.**
- Make sure the wood is clear of the blade before turning on the saw.
- Let the blade build up to full speed before feeding the workpiece into the blade.

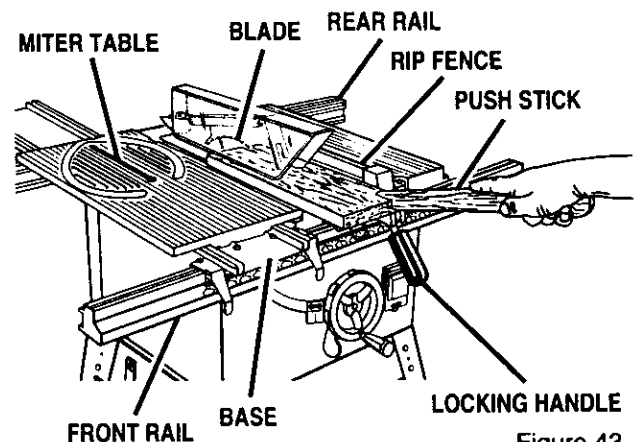

Figure 43

OPERATION

TO MAKE A BEVEL CROSS CUT

See Figure 44.

It is recommended that you place the piece to be saved on the left side of the blade and that you make a test cut on scrap wood.

- ▲ **WARNING:** Make sure the blade guard assembly is installed and working properly to avoid serious personal injury.
- Remove the rip fence by lifting the locking handle.
- Move the bevel locking lever to the right for Angle mode. Turn the blade adjustment handle until the bevel indicator is at the desired angle. Push the bevel locking lever securely to the left to lock the angle.
- Set the blade to the correct depth for the workpiece.
- Loosen the adjusting clamp on the miter fence. Set the miter fence to 90 degrees with either the quick-stop or the miter scale.
- Make sure the miter fence will not contact the blade as the wood feeds into the blade. Make a trial pass of the miter table. The end of the miter fence should not contact the blade. Loosen the adjusting clamp to move it away from the blade if needed.
- Place a support (the same height as saw table) behind the saw for the cut work.
- Make sure the wood is clear of the blade before turning on the saw.
- Let the blade build up to full speed before moving the miter table to feed the workpiece into the blade.
- Hold the work with both hands and push the miter table to feed the work into the blade.

TO MAKE A BEVEL RIP CUT

See Figure 45.

It is recommended you make test cuts on scrap wood.

- ▲ **WARNING:** The rip fence must be on the left side of the blade to avoid trapping the wood and causing kickback.
- ▲ **WARNING:** Make sure the blade guard assembly is installed and working properly to avoid serious personal injury.

Before making this cut, use scrap wood to make an insert 5 in. wide, 22 in. long, and 3/4 in. thick. You may want to make others that are more than 5 in. wide.

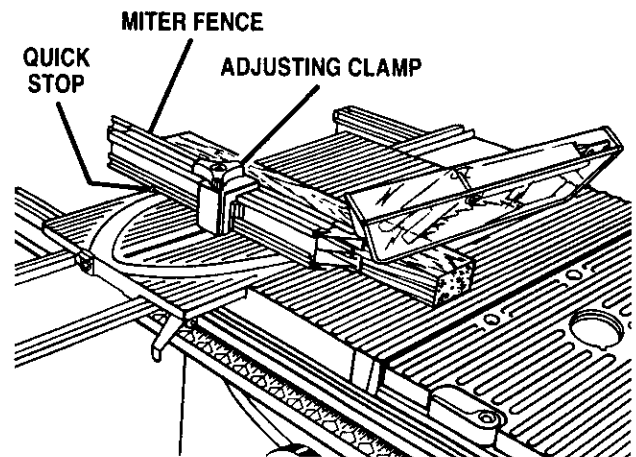

Figure 44

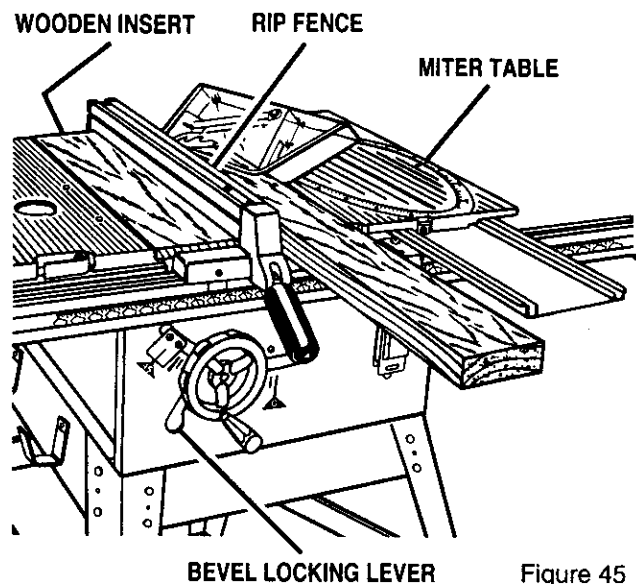

Figure 45

- Remove miter fence, sliding miter table, and accessory table.
- Replace accessory table on the left side of blade. **Do not lock.**
- Place the wooden insert between the accessory table and the saw table to support the workpiece. See Figure 45. Secure the wooden insert with screws as noted. Adjust the accessory table firmly against the wooden insert and lock securely. **Note:** The wooden insert should be attached with wood screws from the bottom, through the two holes provided in the casting. Securely trap the wooden insert between the accessory table and the saw table.
- Place sliding miter table on the right side of blade and lock securely.
- Attach the rip fence over the front and rear rails on the left side and lock securely. Reset the scale to the blade if needed.

OPERATION

- Move the bevel locking lever to the right for Angle mode. Turn the blade adjustment handle until the bevel indicator is at the desired angle. Push the bevel locking lever securely to the left to lock the angle.
- Position the rip fence the desired distance from the blade for the cut and lock securely.
- Place a support (the same height as saw table) behind the saw for the cut work. See Quick Fold Table in Accessories on page 9.
- Use a push stick to move small pieces of wood past the blade. **Never push a small piece of wood into the blade with your hand.**
- Stand to the side of the wood as it contacts the blade to reduce the chance of injury should kickback occur. **Never stand directly in the line of cut.**
- Make sure the wood is clear of the blade before turning on the saw.
- Let the blade build up to full speed before feeding the workpiece into the blade.

TO MAKE A COMPOUND MITER CUT

This cut is made with both the miter fence and the blade angled. Set the miter fence and the blade angle with the procedures given earlier.

The miter fence must be on the left side of the blade. It is highly recommended that you test the cut with a piece of scrap wood. Become thoroughly familiar with bevel cross cuts and miter cuts before attempting to perform a compound miter cut.

TO MAKE A LARGE PANEL CUT

See Figure 46.

Make sure the saw is properly secured to a work surface so it will not tip over under the weight of a large panel.

⚠ WARNING: Make sure the blade guard assembly is installed and working properly to avoid serious personal injury.

- Raise the locking handle on the rip fence to allow the rails to move freely.
- Lift off the sliding miter table assembly by raising the miter locking clamps to release the grippers.
- Remove the accessory table by swinging out the lever and lifting the table up and out.

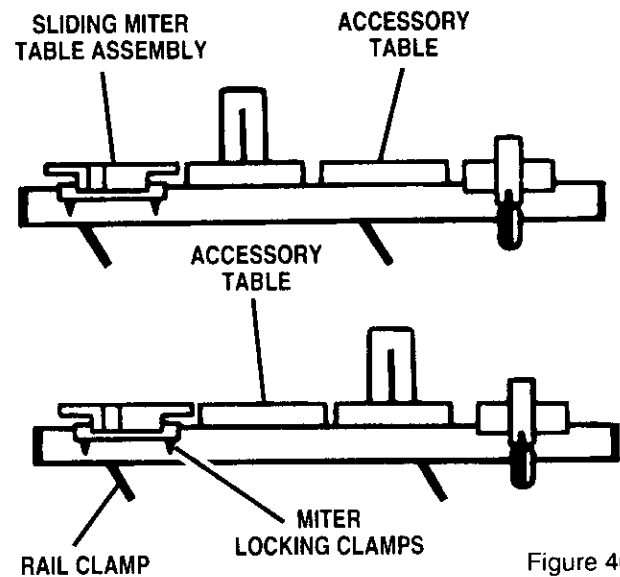

Figure 46

- Rotate the front rail clamps (under the front rail) to the left and slide the front rail to the side where the panel will rest. Lock the rail clamps after positioning the front rail.
- Rotate the rear rail clamps (under the rear rail) to the left and position the rear rail to support the panel. Align the rear rail with the front rail. Lock the rail clamps after positioning the rear rail.
- Place the accessory table onto the rails far enough from the blade to help support the panel and lock securely.
- Place the sliding miter table assembly onto the rails and lock securely. The miter table can be rotated 180 degrees so the projecting base is at the back of the work surface so you won't run into it as you feed the panel into the blade. (Tables can be placed on either side of blade.)
- Position the rip fence the desired distance from the blade for the cut and securely lock the handle.
- Place a support behind the saw for the cut work. See Wide Table Kit and Quick Fold Table in Accessories on page 9.
- Make sure the panel is clear of the blade before turning on the saw.
- Let the blade build up to full speed before feeding the workpiece into the blade.

OPERATION

TO MAKE NON-THROUGH CUTS

Non-through cuts can be made with the grain (ripping) or across the grain (crosscut). The use of a non-through cut is essential to cutting grooves, rabbets, and dadoes. This is the only type cut that is made without the blade guard installed. Make sure the blade guard assembly is reinstalled upon completion of this type of cut. Read the appropriate section which describes the type of cut in addition to this section on non-through or dado cuts. For example, if your non-through cut is a straight cross cut, read and understand the section on straight cross cuts before proceeding.

⚠ WARNING: Unplug the saw to avoid possible injury.

- Remove the three screws holding the throat plate in place. Remove the throat plate.
- Raise the saw blade by pushing the bevel locking lever to the left and rotating the blade adjusting handle clockwise.
- Put the saw in Angle mode by pushing the bevel locking lever to the right. Turn the blade adjusting handle until the blade indicator shows a 30 degree angle. Push the bevel locking lever securely to the left to lock the angle.
- With the box end of the small hex wrench, loosen the two hex nuts at the base of the riving knife. **Do not remove hex nuts.** Remove the riving knife/guard assembly. Retighten the two hex nuts on the base. Insert the throat plate.
- Bring the blade back to 90 degrees.
- Lower the blade to the correct height by turning the blade adjusting handle counterclockwise. Secure throat plate with the three screws.

⚠ WARNING: Carefully check all setups and rotate the blade one full revolution to assure proper clearance before connecting saw to power source.

- Always use push blocks, push sticks, and featherboards when making non-through cuts to avoid the risk of serious injury. *See Figure 47.*

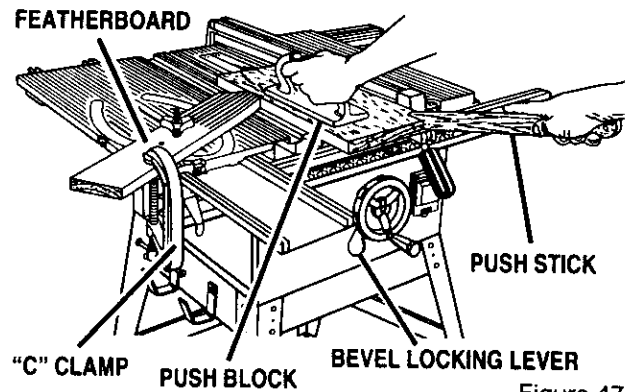

Figure 47

⚠ WARNING: Never feed wood with your hands when making any non-through cut such as rabbets or dadoes.

- When the cut is complete, unplug saw and raise the blade.
- Remove the three screws holding the throat plate in place. Remove the throat plate.
- Push the bevel locking lever to the right. Rotate the blade adjusting handle until the bevel indicator shows a 30 degree angle. Push the bevel locking lever securely to the left while holding the blade adjusting handle to lock the angle. Reinstall the blade guard assembly.
- Retighten the nuts at the base of the riving knife. Check riving knife alignment to the blade and adjust shims if necessary. *See Page 20.*
- Move the bevel locking lever to the right and rotate the blade back to 90 degrees. Push the lever to the left to lock the angle.
- Insert the throat plate, lower the blade and secure with the three screws. Tighten them firmly.

OPERATION

TO MAKE DADO CUTS

A dado is a non-through cut and typically refers to a channel cut, both with the grain and across the grain. An optional dado throat plate is available for your saw. Refer to the accessory section of this manual and check with your nearest Sears Retail Store for information on dado throat plates and blades for your table saw.

- Unplug your saw.

 **WARNING:** Unplug the saw to avoid possible injury.

- Remove the riving knife and guard assembly. See *Figure 19, on page 20.*
- Retighten the two hex nuts on base assembly.
- Remove the blade.
- Remove the appropriate spacers on the blade arbor to get the correct width for the dado blade.
- Mount the dado blade, using the instructions with the dado set.

- Make sure the arbor nut is fully engaged and the arbor extends at least one full thread past a securely tightened arbor nut.
- When mounting dado blades, make sure both the inner blade washer and outer blade washer are used.
- Replace the throat plate with optional Dado Throat Plate.

 **WARNING:** Always put all spacers in proper location when changing back to saw blade. Failure to do so may result in possible injury and damage to the tool.

- Always use push blocks, push sticks, or featherboards when making dado cuts to avoid the risk of serious injury.

 **WARNING:** All blades must be rated for at least 5,500 RPM to prevent possible injury or damage to the tool.

MAINTENANCE

A. GENERAL MAINTENANCE

- ▲ **WARNING:** Always begin by disconnecting the power supply.
- Periodically check all clamps, nuts, bolts, screws, and belts for tightness and condition. Make sure the throat plate is in good condition and in position.
- Check the blade guard assembly.
- To maintain the table surfaces, fence, and rails, periodically apply paste wax to them and buff to provide smooth functioning. To prevent work from slipping during cutting operation, **Do not** wax the working face of the miter fence.
- Protect the blade by cleaning out sawdust from underneath the table and in the blade teeth. Use a resin solvent on the blade teeth.
- **Clean plastic parts only with a soft damp cloth. Do not use any aerosol or petroleum solvents.**

B. SPECIFIC TABLE SAW MAINTENANCE

- ▲ **WARNING:** Always begin by disconnecting the power supply.

TO SET BLADE AT 0 OR 45 DEGREES

The angle settings of your saw have been set at the factory and, unless damaged in shipping, should not require setting during assembly. After extensive use, it may need to be checked.

- Push the bevel locking lever to the right. See *Figure 48*. Turn the blade adjusting handle to angle the blade. Use a combination square to check squareness between the blade and saw table.
- If the blade is not perfectly vertical (0 degrees), loosen the lock nut on the 0 degree bolt inside the cabinet, position the blade, adjust the bolt, then retighten lock nut. See *Figure 48, insert*. If the bevel indicator is not at zero, adjust it with the two screws above the slot, beside the blade adjusting handle.
- Turn the blade adjusting handle until the bottom of the blade has moved completely to the left side of the slot. Lock the angle by pushing the bevel locking lever to the left.
- If the blade is not an exact 45 degrees, loosen the lock nut on the 45 degree bolt inside the cabinet, position the blade, adjust the bolt, then retighten lock nut. See *Figure 48, insert*.
- Make a test cut.

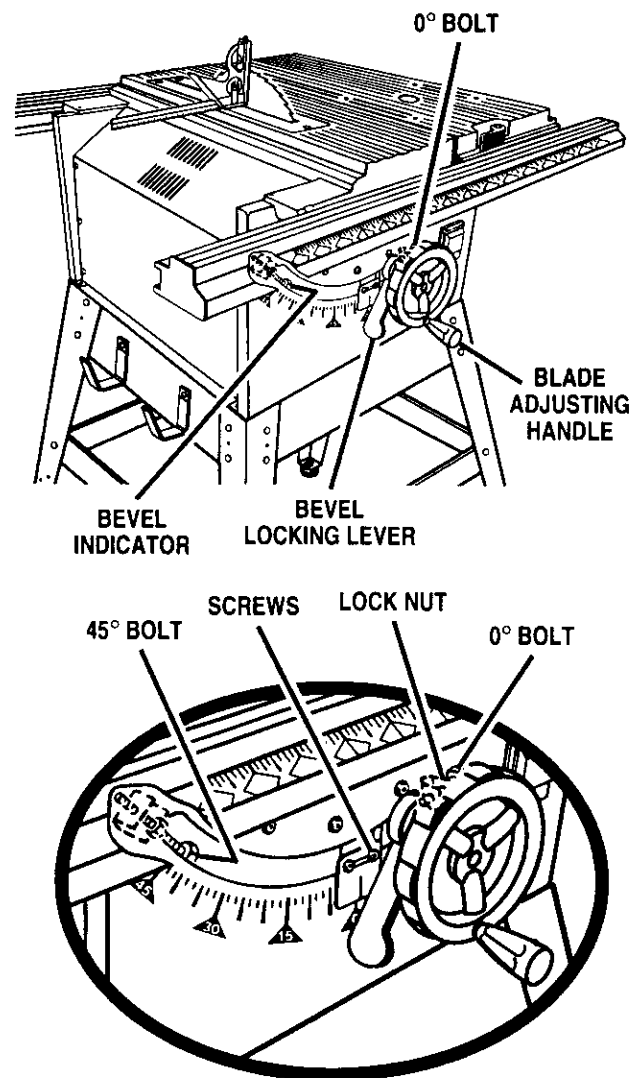

Figure 48

MAINTENANCE

TO CHECK THE ALIGNMENT OF THE RIP FENCE TO THE BLADE

See Figure 49.

- ▲ **WARNING:** Unplug the saw to prevent accidental starting.
- Raise the locking handle to permit the rip fence to be moved.
- Place a framing square beside the blade and move the rip fence up to the square. Take the dimension on the rip scale.
- Move the fence back and turn the framing square 180 degrees to check the other side.
- If the two dimensions are not the same, loosen the two screws on the fence and align it.
See Figure 49.
- Retighten the two screws.
- Make two or three test cuts on scrap wood. If the cuts are not true, repeat the process.

- ▲ **WARNING:** Before plugging the saw back in to make test cuts, make sure the switch is in the **Off** position and the blade guard is in place. Failure to do so may result in serious injury.

TO ADJUST THE BEVEL LOCKING LEVER

The bevel locking lever may work loose and require adjusting. To adjust it, use the following steps.

- Push the lever full left to the locked position.
- Remove the screw on the blade adjusting handle. You will need the 3/16 in. hex key for this procedure.
- Remove the blade adjusting handle and cam. Pull out the cam.
- Remove the set screw on the bevel locking lever.
- Remove the bevel locking lever from hex nut.
- Relocate bevel locking lever on the hex nut.
- Replace set screw and tighten securely.
- Replace the cam so that the lobe is against the tab as shown in Figure 50. Make sure the cam is seated in the lever.
- Reassemble the handle to the shaft and cam. Check whether the lever is now in the desired position. Tighten screw securely.

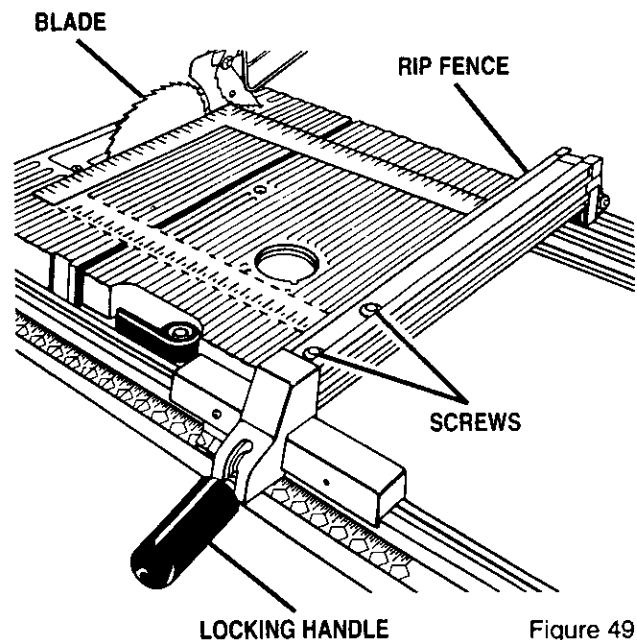

Figure 49

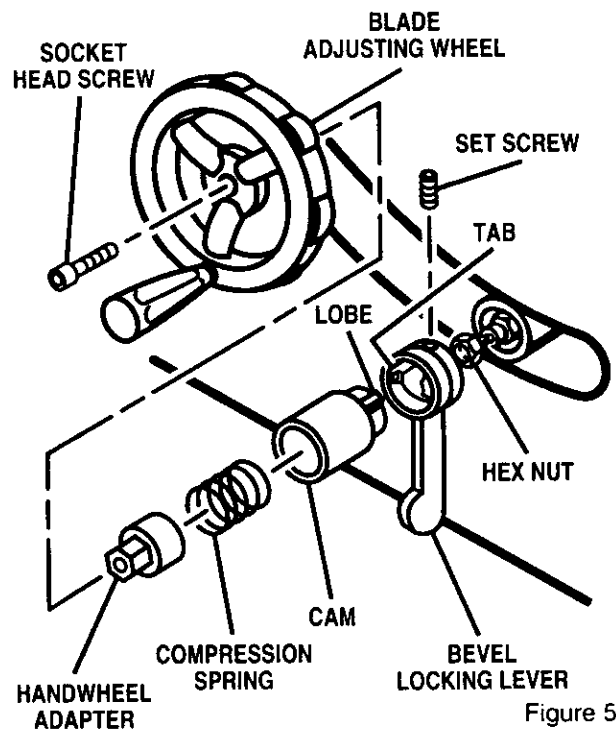

Figure 50

MAINTENANCE

TO ALIGN THE MITER LOCKING CLAMPS

See Figure 51.

⚠ WARNING: Unplug the saw to prevent accidental starting.

The miter locking clamps are preset at the factory but may require adjusting after extended use or if damage occurs in shipping. Adjust them with the following steps:

- Loosen the set screw behind each locking clamp.
- Loosen the screw on top of each locking clamp.
- Lift the locking clamp to the **Up** position.
- Push the clamp forward tight against the front rail to bring the clamp into alignment.
- When the clamps are correctly positioned, retighten the screws and the set screws.
- Push both front and rear miter locking clamps down to secure the sliding miter table.

TO ADJUST THE FRONT AND REAR RAIL CLAMPS

See Figure 52.

The rail clamps are located below the rails and ensure tight attachment of the rail. Following extended use, the rail holder nut inside the rails may need adjusting.

- Remove the miter table and accessory table.
- Remove the front and rear rails by loosening the rail clamps and sliding the rails off.
- Rotate each rail clamp to the left until it hits or comes in contact with the bottom of the saw table.
- Tighten rail holder nut until it is snug.
- Loosen rail holder nut one-fourth (1/4) turn.
- Replace the rails and check the rail clamps.

TO ADJUST THE ACCESSORY TABLE

See Figure 53.

After extended use, the accessory table may work loose causing the accessory table to be loose on the rails. Follow the steps below, when adjustments are required:

- Remove the hex nut on the lever using a 3/8 in. nut driver.
 - Remove the backup plate and spring plate. Rotate the spring plate 180° and reinstall on the handle shaft.
 - Reassemble all parts and tighten hex nut securely.
- Note:** The spring plate offers two ends for use before requiring replacement.

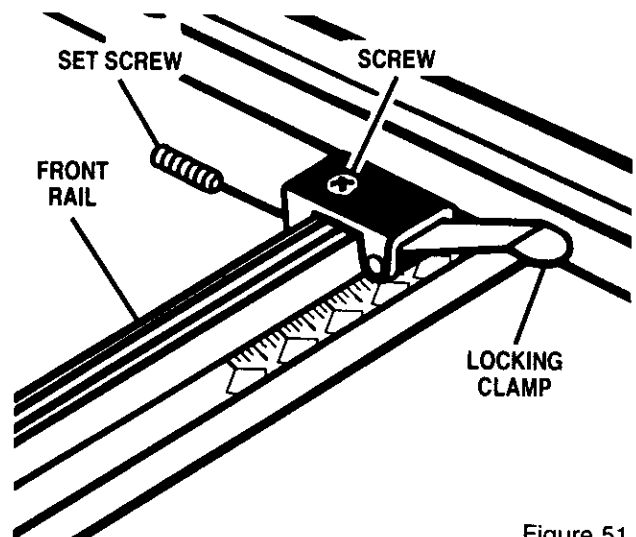

Figure 51

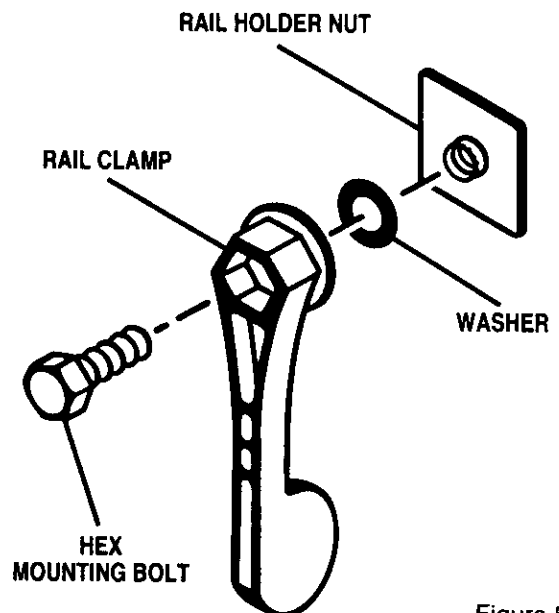

Figure 52

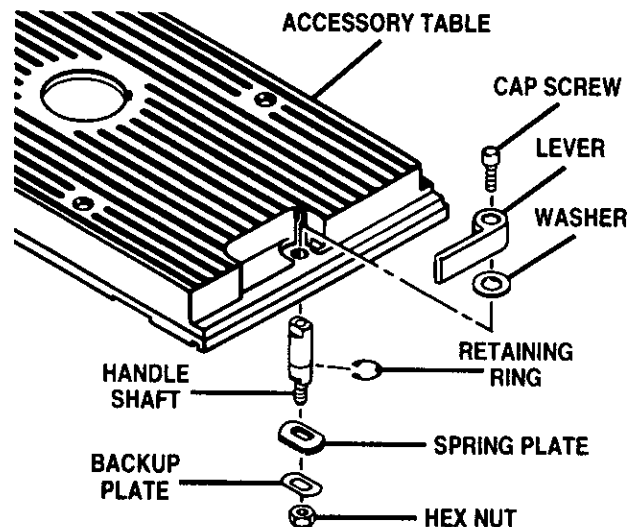

Figure 53

SLIDING MITER TABLE ASSEMBLY

Checks and Adjustments

The sliding miter table assembly has been preset at the factory to be parallel to the blade. However, misalignment during shipping or requirements for very precise and accurate cuts may require realignment. The square relationship between the blade and the miter fence as it travels the entire distance from the front to the rear of the miter table base during a cut is very important for making precise and accurate cuts.

To avoid unnecessary setups and adjustments, we suggest that you check these setups carefully with a framing square and make practice cuts in scrap wood before making finish cuts in good workpieces.

Note: Follow the general rule of measuring twice and cutting once.

Do not loosen any screws for the following adjustments until you have made checks and are sure adjustments are needed. Once screws have been loosened, these settings must be reset.

Two basic checks should be made to determine if adjustments are necessary:

- The miter base must be parallel to the blade as the table slides from the front to the rear of the miter table assembly.
- The miter fence must be square to the blade when set at exactly zero (0°) on the miter table scale. This is necessary in order to be able to use the scale on the miter table. The miter table has adjustment screws for squaring miter fence to blade and maintaining 0° scale settings when miter base adjustments are required.

Note: These checks and adjustments are being explained in step by step procedures, however, you should be aware that they depend upon each other.

SLIDING MITER TABLE ASSEMBLY

Checks and Adjustments

CHECKING SLIDING MITER TABLE ASSEMBLY

⚠ WARNING: For illustration purposes, the blade guard and anti-kickback pawls have been removed. Do not operate your saw without the blade guard unless specifically instructed to do so for non-through cuts.

TO CHECK MITER BASE PARALLELISM

⚠ WARNING: Begin by unplugging your saw. Failure to unplug saw could result in accidental starting causing possible serious injury.

- Set saw up as if you were preparing to make a cut. Tighten rail clamps, miter locking clamps, adjusting clamp, etc.
- Slide miter table (A) to the front of miter base (B) as far as it will go. Place a reference mark (C) near the end of the miter table as shown in figure 54.

Note: Front of miter base is on infeed side of saw.

- Place a reference mark on one of the blade teeth (D) and rotate the blade (E) so that the reference mark on the blade is at the front of the throat plate (F).
- Place a framing square (G) against the blade and align with reference mark on miter table. Measure the distance between the blade and the edge of miter table.

Note: Place framing square between carbide teeth and measure from blade. This step will insure framing square is square against blade from the front to back of blade.

- Remove framing square and slide miter table to the rear of miter base as far as it will go. See Figure 55.
- Rotate the blade so the reference mark on the blade is at the rear of the throat plate. Measuring from the same mark on the blade at the rear will eliminate the effect of blade wobble.
- Place framing square against the blade and align with the same reference mark on the miter table. Measure the distance between the blade and the edge of the miter table at the rear.
- Compare whether the front and rear measurements are the same. If they are the same, proceed with checking the miter fence alignment. If not, this indicates the miter base needs aligning. Miter base must then be adjusted before checking miter fence alignment. See "To Adjust The Miter Base" section that follows.

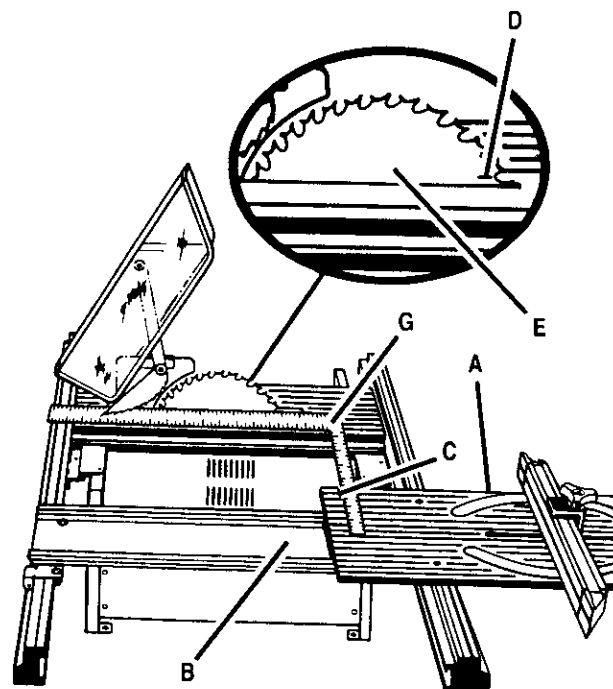

Figure 54

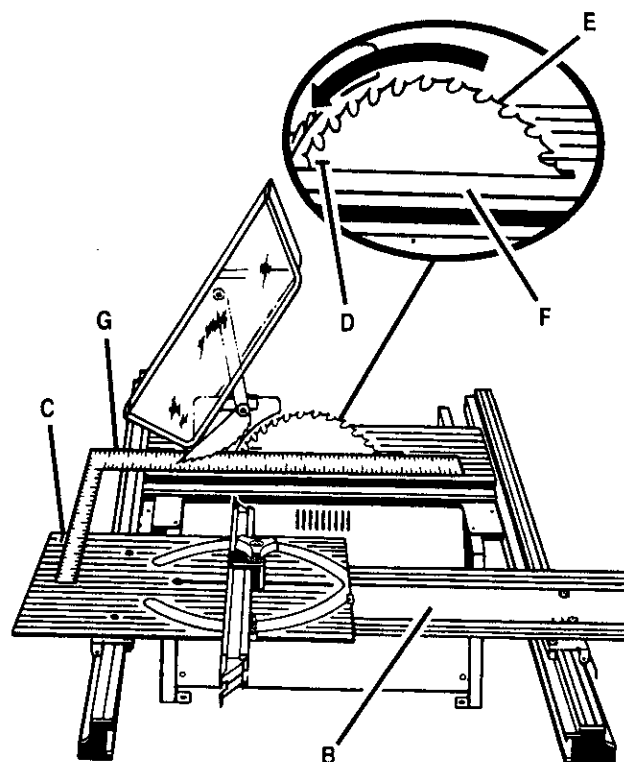

Figure 55

SLIDING MITER TABLE ASSEMBLY

Checks and Adjustments

TO CHECK MITER FENCE ALIGNMENT

The miter fence must be perpendicular to the blade when set at zero degrees.

- Set the miter fence (H) at 0° as shown in figure 56. Miter indicator (I) should be set precisely on 0° and secured in place with adjusting clamp (J).

Note: The quick-stop is not necessary for this checking procedure. However, you may want to check and adjust it to 0° at this time. See "Quick-Stop" section that follows.

- Place a framing square (G) firmly against the miter fence (H), with the other side against the blade (E). See Figure 56.
- Check whether the miter fence and blade are square with each other. With the framing square against the miter fence there should be no gap from the front to the rear of the blade.
- If a gap exists, the miter fence may be out of square.
- Rotate the blade and recheck. If there is a consistent gap between the front and rear of the blade, the miter table needs aligning. Follow the adjustment procedures that follow.

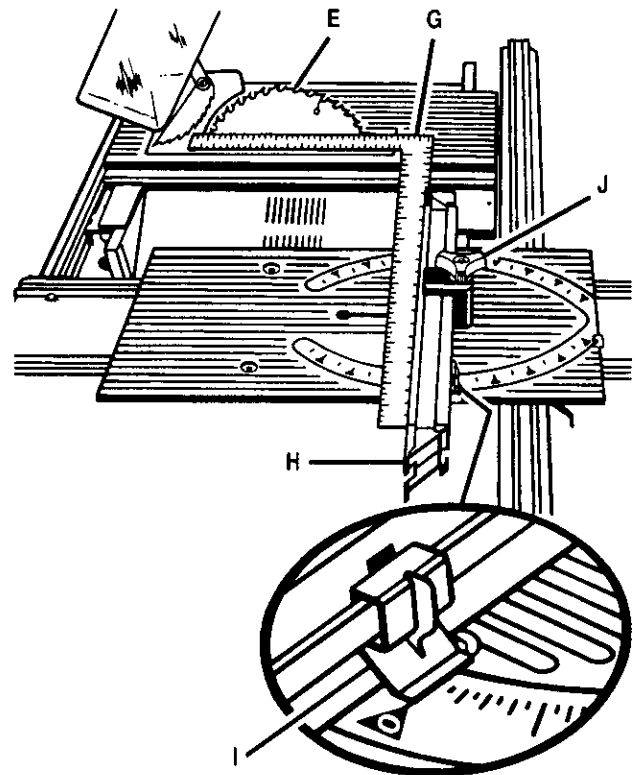

Figure 56

MAKING ADJUSTMENTS TO SLIDING MITER TABLE ASSEMBLY

TO ADJUST THE MITER BASE

Remember: Check all settings before loosening screws for the following procedures. Once screws have been loosened, these settings must be reset.

Eight screws are visible on the miter base (B).

- Four screws (K) are on the holder plates and secure these plates to the rails. It is not necessary to loosen or adjust these screws for this adjustment procedure.
- Another pair of screws (L) is in the base, at the rear. Loosen these two screws (L) and the rear miter locking clamps (M). See Figure 57.
- The last pair of screws is located on the infeed side of the base. Loosen the left screw (N) **only**.
- The right screw (O) will be used as a pivot point. **Note:** The front two miter locking clamps (P) and rail clamps should remain locked.
- Following steps 2 thru 8 in "To Check Miter Base Parallelism", adjust the miter base so that it is parallel to the blade.
- Retighten the left front screw (N).
- Clamp the rear miter locking clamps (M).
- Retighten the two rear screws (L).

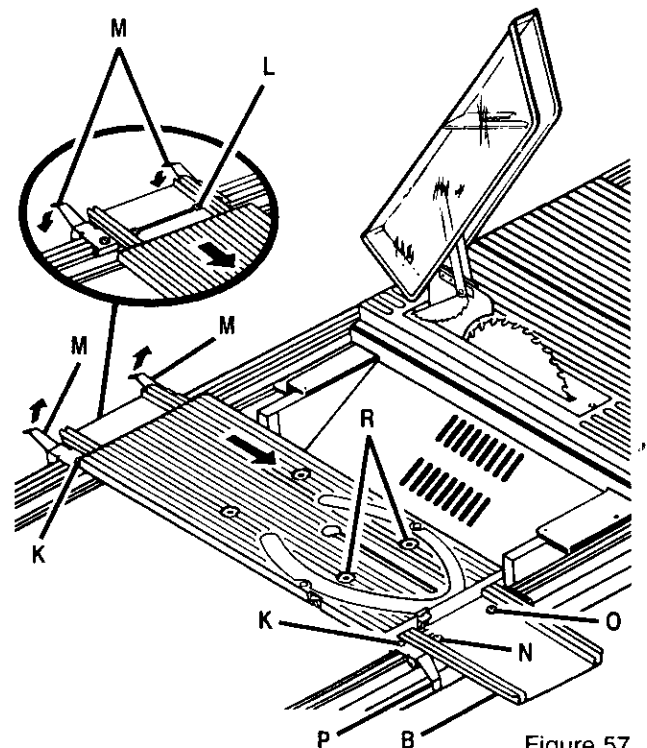

Figure 57

SLIDING MITER TABLE ASSEMBLY

Checks and Adjustments

TO ADJUST THE MITER FENCE

- Set the miter fence (H) at 0° as shown in figure 56. Miter indicator (I) should be set precisely on 0° and secured in place with adjusting clamp (J).
- There are four slides located under the sliding miter table. These slides let the miter table move on the base. Three slides are mounted on eccentric screws that can be adjusted by loosening the hex nuts on top of the miter table. See Figure 58.
- Loosen the rear hex nuts (Q) on top of sliding miter table for this adjustment procedure.

Note: The front screws (R) are only needed to remove excessive play in the slides due to wear from extended use. They are **not** needed for this procedure. The right front hex nut is a non-eccentric pivot and should never be loosened.
- Adjust the right rear eccentric screw from the lower side of the miter table so that maximum play exists between the slide and miter base.
- Push left rear of miter table snugly against miter base as shown by the arrow (S) in figure 59 and secure.
- Place a framing square firmly against the miter fence, with the other side against the blade.
- Adjust left rear screw from underneath miter table until miter fence and blade are square with each other.
- Tighten hex nut securely.
- Adjust right rear screw from underneath miter table to remove excessive play.
- Tighten hex nut securely.
- Recheck your setups carefully. Also make sure all screws, hex nuts, etc. have been tightened securely.
- If sliding miter table assembly is still not square with the blade, repeat the above procedures as needed.
- Make sure that slides remain square to miter base edge to prevent "cocking" which will result in excessive play in miter table.

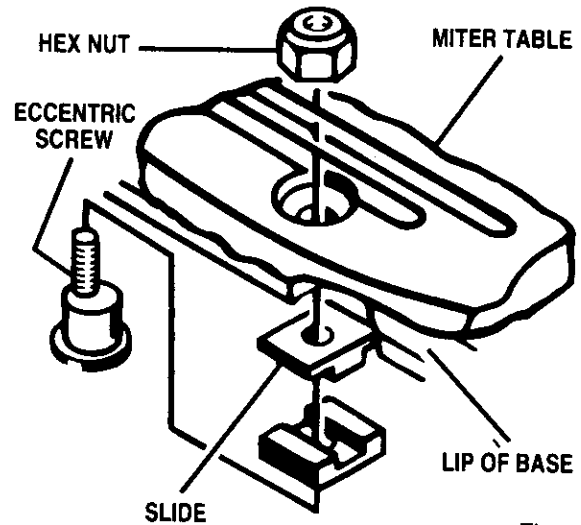

Figure 58

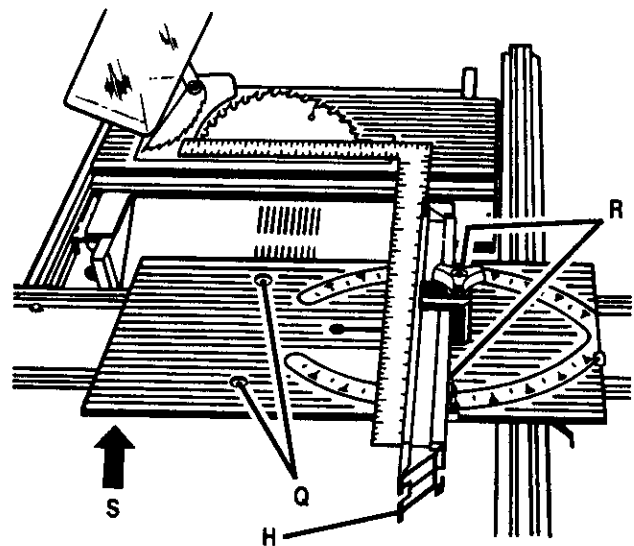

Figure 59

SLIDING MITER TABLE ASSEMBLY

Checks and Adjustments

TO ADJUST QUICK-STOP

The quick-stop is preset at the factory to stop the miter fence at exactly zero degrees. However, when sliding miter table adjustments are made, these adjustments may cause the quick stop to need adjusting. Check quick-stop with miter scale set at zero degrees. If adjustments are needed, proceed with the following steps:

- Loosen the eccentric screw holding the quick-stop.
- Place the quick-stop against the miter fence with miter scale set at zero degrees. *See Figure 60.*
- Adjust eccentric screw until it holds quick-stop securely against miter fence.
- Retighten hex nut, securing eccentric screw and quick-stop.
- Check your work. If the quick-stop is not at zero degrees, repeat steps 1-4.

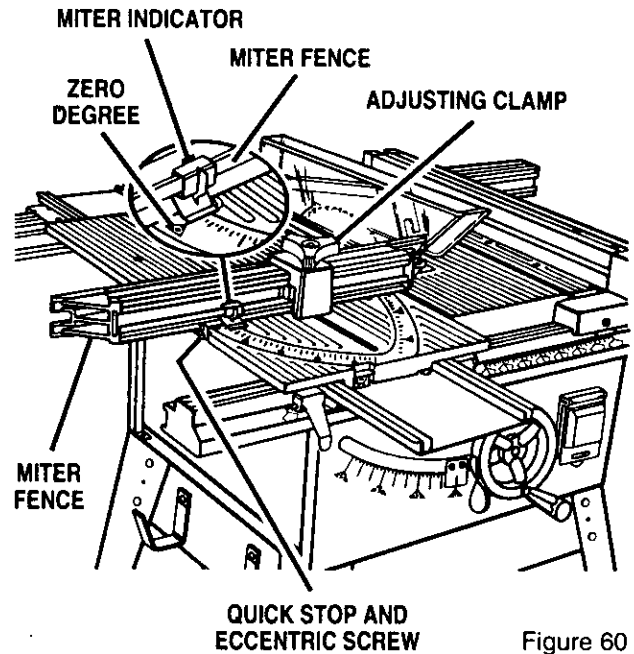

Figure 60

LUBRICATION

This saw has been lubricated at the factory prior to shipment. Following extended use, you should inspect and lubricate the following areas to assure smooth operation.

LOCKER BRACKET ASSEMBLY

See Figure 61.

- Add dry lube between both bevel gears, the backup washers and the locker bracket.
- Add dry lube between threaded hole in motor casting and threaded elevating shaft.

Recommended Lubricants:

Dry Silicone or Teflon Lubricant

TILT / ELEVATING MECHANISM

See Figure 62.

- Add dry lube between the handle shaft and the bore of the clamping bolt.
- Add dry lube between the face of the clamping bolt and the face of the handle shaft.
- Add dry lube on the inner surfaces of the bevel locking lever which contacts the cam.

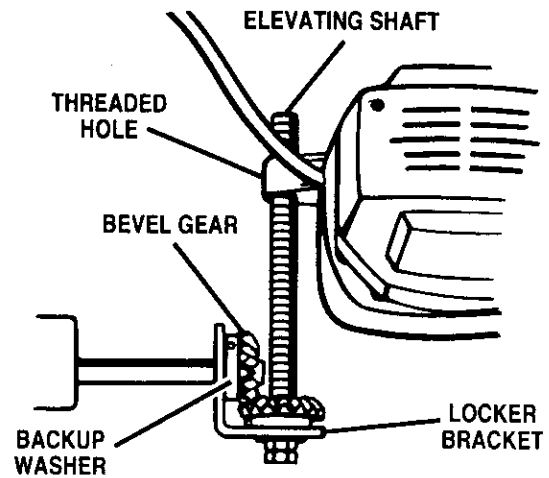

Figure 61

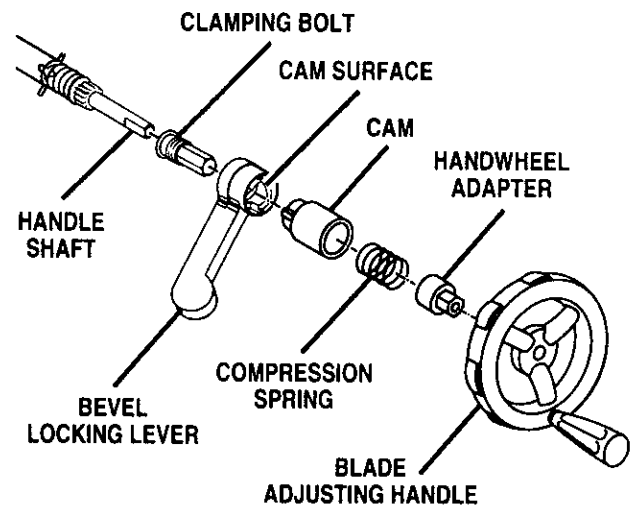

Figure 62

TROUBLESHOOTING

Problem	Cause	Solution
Excess vibration.	Blade is out of balance.	Replace blade.
	Blade is damaged.	Replace blade.
	Saw is not mounted securely.	Tighten all hardware.
	Work surface is uneven.	Reposition on flat surface. Adjust legs of optional stand.
	Blade is warped	Check Saw Blade Installation on page 19. Replace blade if necessary.
Rip fence does not move smoothly.	Rip fence not mounted correctly.	Remount the rip fence.
	Rails are dirty or sticky.	Clean and wax rails.
	Clamp screw is out of adjustment.	Adjust clamp screw counterclockwise.
Rip fence does not lock at rear.	Clamp screw is out of adjustment.	Adjust clamp screw clockwise.
Cutting binds or burns work.	Blade is dull.	Replace or sharpen blade.
	Blade is heeling.	Align miter base.
	Work is fed too fast.	Slow the feed rate.
	Rip fence is misaligned.	Align the rip fence.
	Riving knife is misaligned.	Adjust the riving knife with shims provided.
	Wood is warped.	Replace the wood. Always cut with convex side to table surface.
Wood edges away from rip fence when ripping.	Rip fence is misaligned.	Check and adjust the rip fence.
	Blade not properly sharpened or set.	Re-sharpen or set blade.
Sliding miter table assembly does not move smoothly.	Miter base or slides improperly adjusted.	See page 37 for Adjustments To Sliding Miter Table Assembly

TROUBLESHOOTING

Problem	Cause	Solution
Saw does not make accurate 90 or 45 degree cuts.	Positive stops inside cabinet need adjusting (Bevel Cuts).	Adjust positive stops.
	Miter gage is misaligned (Miter Cuts).	Adjust the miter gage.
Blade adjusting handle is hard to turn.	Gears or Screw Post inside cabinet are clogged with sawdust.	Clean the gears or screw post.
Saw does not start.	Motor cord or wall cord is not plugged in.	Plug in motor cord or wall cord.
	Circuit fuse is blown.	Replace circuit fuse.
	Circuit breaker is tripped.	Reset circuit breaker.
	Cord or switch is damaged.	Have the cord or switch replaced at your Sears Service Center/Department.
Blade makes poor cuts.	Blade is dull or dirty.	Clean, sharpen or replace blade.
	Blade is wrong type for cut being made.	Replace with correct type.
	Blade is mounted backwards.	Remount blade.
Blade does not lower when turning blade adjusting handle.	Back side of riving knife has come in contact with saw table.	Realign and adjust the riving knife.
	Locking lever is not at full left position.	Move locking lever to left.
Motor labors in rip cut.	Blade not proper for rip cut.	Change blade; rip blade typically has fewer teeth.

CRAFTSMAN 10 in. TABLE SAW – MODEL NO. 315.228110

FIGURE A: 10 in. TABLE SAW

FOR MITER TABLE ASSEMBLY,
REFER TO FIGURE B

FOR BLADE GUARD ASSEMBLY,
REFER TO FIGURE D

FOR RIP FENCE ASSEMBLY,
REFER TO FIGURE C

FOR LEG STAND ASSEMBLY,
REFER TO FIGURE F

FOR MOTOR ASSEMBLY,
REFER TO NOTE "A", PAGE 48

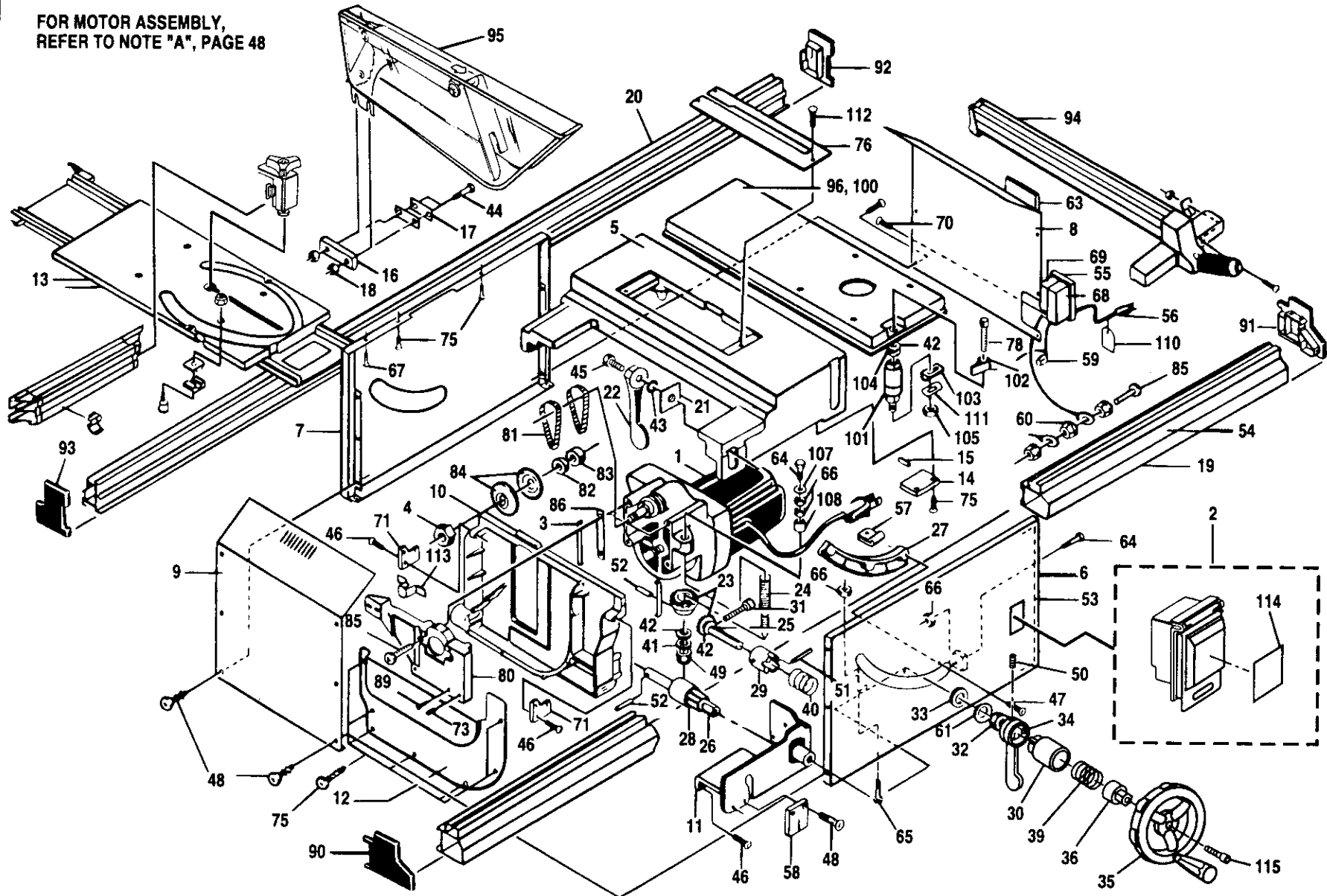

CRAFTSMAN 10 in. TABLE SAW – MODEL NO. 315.228110

PARTS LIST – FIGURE A

The model number will be found on a plate attached to the side panel of the cabinet. Always mention the model number in all correspondence regarding your **TABLE SAW** or when ordering repair parts.

Key No.	Part Number	Description	Quan.	Key No.	Part Number	Description	Quan.
1	969214-008	Motor Assembly	1	43	706382-346	Washer	4
2	663283-001	Off/On Switch Assembly	1	44	**STD523110	*Hex Bolt (#5/16-18 x 1 in.)	2
3	969600-001	Shim	2	45	**STD523107	*Hex Bolt (#5/16-18 x 3/4 in.)	4
4	969226-001	*Hex Nut (#5/8-18)	1	46	662493-002	*Screw (#10-24 x 5/8 in. Pan Hd.)	8
5	969101-005	Saw Table	1	47	**STD511007	*Screw (#10-24 x 5/8 in. Pan Hd.)	3
6	662884-005	Front Cabinet Panel	1	48	**STD600803	*Screw (#8-32 x 3/8 in. Pan Hd.)	16
7	969103-005	Rear Cabinet Panel	1	49	**607406-005	*Nylon Hex Nut (#3/8-16)	1
8	969104-007	Right Cabinet Panel	1	50	**STD502503	*Set Screw (#1/4-20 x 3/8 in.)	1
9	969105-005	Left Cabinet Panel	1	51	941401-018	Roll Pin	1
10	969529-002	Locker Bracket	1	52	941401-831	Roll Pin	2
11	661694-003	Clamper Bracket	1	53	981505-001	Name Plate	1
12	969548-002	Dust Cover	1	54	981506-001	Scale Label	1
13	969176-905	Miter Table Assembly	1	55	969137-001	Outlet (15 Amp Single Pole)	1
14	969113-001	Clamp Plate	2	56	969138-001	Cord	1
15	623924-002	Needle Roller (1/4 in. x 3/4 in.)	2	57	989001-001	Cable Clamp	1
16	662481-001	Clamp	1	58	969140-001	Bevel Indicator	1
17	969193-001	Shim	5	59	**STD375005	Wire Nut	1
18	**STD541031	*Hex Nut (#5/16-18)	2	60	**STD541408	*Lock Nut (#8-32 Hex)	3
19	969117-001	Front Rail	1	61	969142-001	Cone Disc Spring	1
20	969924-001	Rear Rail	1	63	981504-001	Data Plate	1
21	969251-002	Rail Holder Nut (#5/16)	4	64	**STD522510	*Bolt (#1/4-20 x 1 in. Hex)	2
22	663144-001	Rail Locking Clamp	4	65	**STD522520	*Bolt (#1/4-20 x 2 in. Hex)	1
23	969122-002	Bevel Gear	2	66	**STD541025	*Hex Nut (#1/4-20)	4
24	969123-002	Shaft	1	67	968705-004	*Screw (#10-24 x 5/16 in. Pan Hd.)	2
25	969124-002	Gear Shaft	1	68	969230-001	Plug Socket Box (A)	1
26	969125-002	Handle Shaft	1	69	969229-001	Plug Socket Box (B)	1
27	969126-001	Gear Rack	1	70	968702-011	*Screw (#8-16 x 3/4 in. Pan Hd.)	4
28	969127-001	Tilting Gear	1	71	664087-001	Locker Support	2
29	969128-001	Clutch	1	73	**STD501003	*Set Screw (#10-24 x 3/8 in.) ...	4
30	969129-002	Cam	1	75	**STD601005	*Screw (#10-24 x 1/2 in. Pan Hd.)	15
31	998292-002	*Screw (#8-32 x 1-3/16 in. Fil. Hd.)	1	76	969605-004	Throat Plate	1
32	**STD541175	*Hex Nut (#3/4-16)	1	78	969220-002	*Cap Screw (#1/4-20 x 3/4 in.)	1
33	661796-001	Washer	1	80	969212-001	Guide Holder	1
34	969130-001	Locking Lever	1				
35	977227-002	Handwheel Assembly (Includes Key No. 115)	1				
36	981817-001	Handwheel Adapter	1				
39	969222-001	Spring	1				
40	969221-001	Spring	1				
41	706382-359	Washer	1				
42	706382-360	Washer	3				

CRAFTSMAN 10 in. TABLE SAW – MODEL NO. 315.228110

PARTS LIST – FIGURE A – Cont'd

Key No.	Part Number	Description	Quan.	Key No.	Part Number	Description	Quan.
81	662329-001	V Belt	2	97	661797-002	Warning Label	1
82	662062-001	1/4 in. Spacer	1	100	969173-007	Accessory Table	1
83	662062-002	1/2 in. Spacer	1	101	969174-004	Handle Shaft	1
84	969205-001	Blade Washer	2	102	969175-002	Handle	1
85	**STD510807	*Screw (#8-32 x 3/4 in. Pan Hd.)	3	103	969216-001	Spring Plate	1
86	969599-001	Shim	2	104	**STD581037	Retaining Ring	1
89	**STD511010	*Screw (#10-24 x 1 in. Pan Hd.)	4	105	**STD541025	*Hex Nut (#1/4-20)	1
90	662406-001	End Cap F1 (front left)	1	107	706382-343	Washer	1
91	662407-001	End Cap F2 (front right)	1	108	661853-001	Spacer	1
92	662408-001	End Cap R1 (right rear)	1	110	661574-001	Hang Tag	1
93	662409-001	End Cap R2 (left rear)	1	111	661992-002	Back-Up Plate	1
94	969143-001	Rip Fence Assembly	1	112	622183-052	*Screw (#10-24 x 3/4 in. Flat Hd.)	3
95	969165-001	Blade Guard Assembly	1	113	662080-001	Bolt Holder	1
96	969172-003	***Accessory Table Assembly	1	114	664105-001	Switch Cover Label	1
				115	**STD512510	*Cap Screw (#1/4-20 x 1 in.)	1

*Standard Hardware Item — May Be Purchased Locally

**Available From Division 98 — Source 980.00

***Item 96 Includes Parts 42, 78, 100 through 105, and 111

NOTE: "A" — The assembly shown represents an important part of the double insulated system. To avoid the possibility of alteration or damage to the system, service should be performed by your nearest Sears Repair Center. Contact your nearest Sears Retail Store for Service Center information.

⚠ WARNING: Improper repair of a double insulated product can result in damages to the double insulation system possibly causing electrical shock or electrocution. Any repairs requiring disassembly of your table saw requires safety testing to be performed by your nearest Sears Repair Center. Contact your nearest Sears Retail Store for Service Center information.

CRAFTSMAN 10 in. TABLE SAW – MODEL NO. 315.228110

FIGURE B: SLIDING MITER TABLE ASSEMBLY

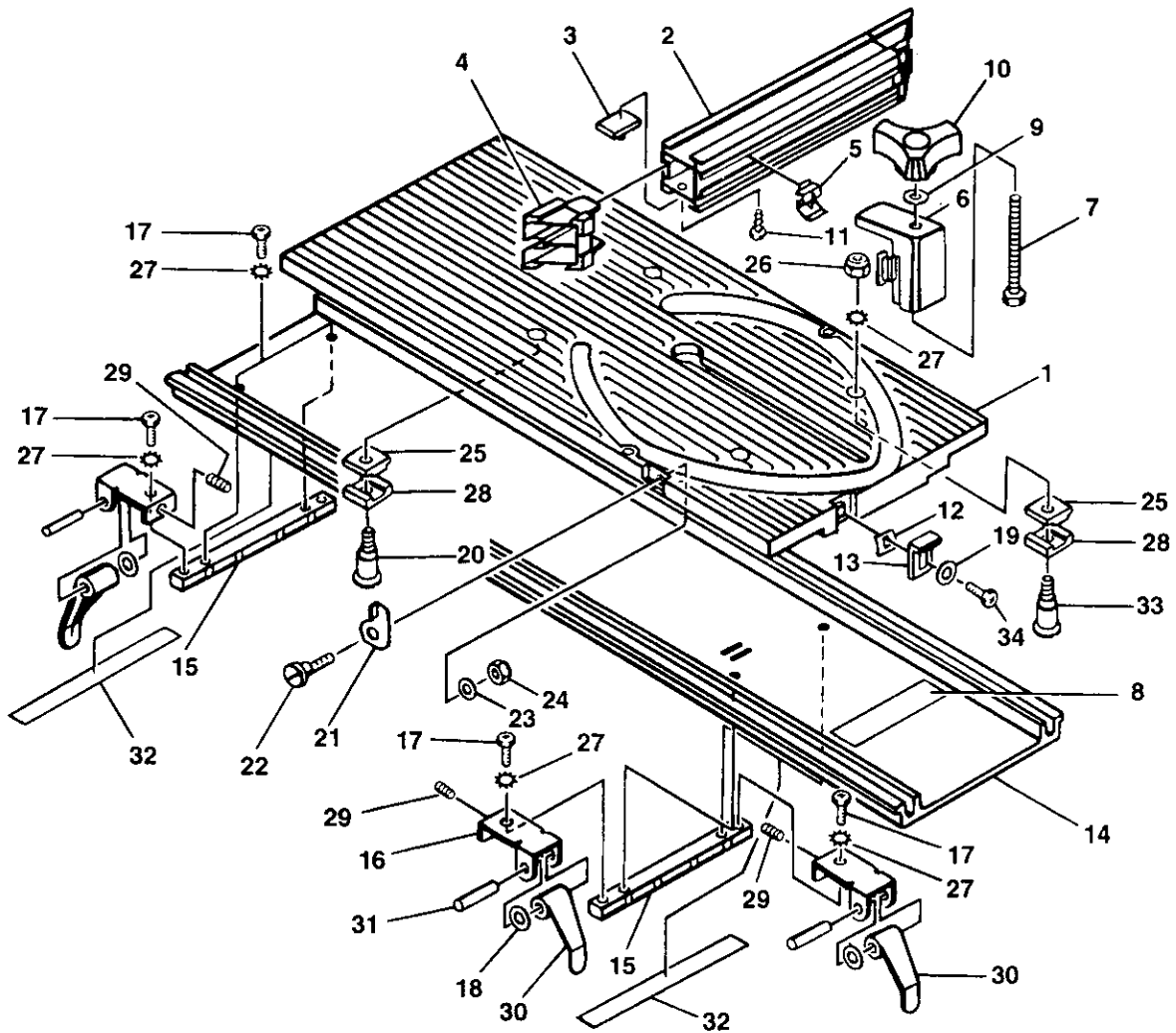

Key Part No.	Part Number	Description	Quan.	Key Part No.	Part Number	Description	Quan.
1	969177-004	Miter Table Top	1	18	607617-003	*O-Ring	4
2	969188-001	Miter Fence	1	19	621721-010	Washer	1
3	661811-001	Pivot	1	20	969502-001	Eccentric Screw (10-24)	3
4	969190-001	Saw Gage	2	21	969500-001	Quick Stop	1
5	969191-001	Miter Indicator	1	22	969501-002	Eccentric Screw (8-32)	1
6	969192-001	Fence Holder	1	23	621721-001	Washer	1
7	**STD523132	*Bolt (5/16-18 x 3-1/4 in. Hex Hd.)	1	24	703477-006	*Hex Nut W/Elastic Stop (8-32)	1
8	661797-002	Warning Label	1	25	661844-001	Slide (A)	4
9	**STD551031	Washer	1	26	703477-059	*Hex Nut W/Elastic Stop (10-24)	4
10	969194-001	Adjusting Clamp	1	27	**STD551210	Lock Washer	12
11	968702-009	*Screw (8-16 x 5/8 in. Pan Hd.)	2	28	661845-001	Slide (B)	4
12	969227-001	Spring Plate	1	29	**STD501002	*Set Screw (10-24 x 1/4 in. Hex Socket)	4
13	969225-001	Stopper Plate	1	30	969915-002	Miter Locking Clamp	4
14	969228-003	Miter Base	1	31	**STD572512	Roll Pin	4
15	969598-002	Guide Bar	2	32	661706-001	Guide Plate	2
16	969916-006	Holder Plate	4	33	662306-001	Non-Eccentric Screw (10-24)	1
17	968705-041	*Screw (10-24 x 15/32 in. Pan Hd.)	8	34	**STD601005	*Screw (10-24 x 1/2 in. Pan Hd.)	1

* Standard Hardware Item — May Be Purchased Locally **Available From Division 98 — Source 980.00

CRAFTSMAN 10 in. TABLE SAW – MODEL NO. 315.228110

FIGURE C: RIP FENCE ASSEMBLY

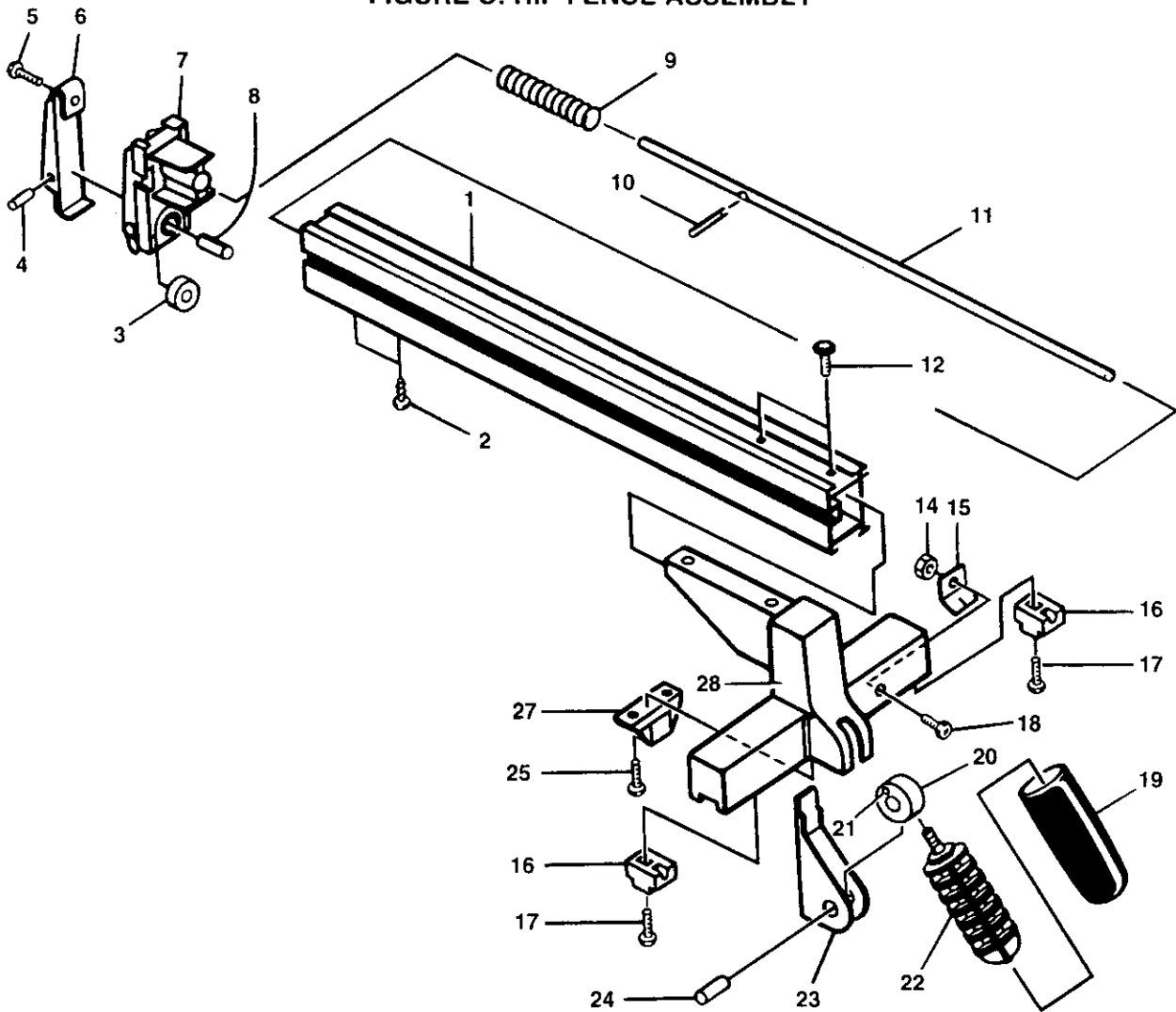

Key Part No.	Number	Description	Quan.	Key Part No.	Number	Description	Quan.
1	969144-001	Rip Fence	1	14	**STD541008	*Hex Nut (8-32)	1
2	968704-006	*Screw (10-14 x 1/2 in. Pan Hd.)	2	15	969153-001	Scale Indicator	1
3	969155-001	Fence Roller	1	16	969240-001	Slide	2
4	941401-309	Roll Pin	1	17	**STD600805	*Screw (8-32 x 1/2 in. Pan Hd.)	2
5	**STD511010	*Screw (10-24 x 1 in. Pan Hd.)	1	18	**STD510805	*Screw (8-32 x 1/2 in. Pan Hd.)	1
6	969254-001	Clamper - B	1	19	969912-004	Locking Handle Grip	1
7	969154-002	Roller Holder	1	20	969146-003	Eccentric Roller	1
8	969114-001	Needle Roller	1	21	623019-004	Rubber Plug	1
9	969253-001	Compression Spring	1	22	969148-001	Locking Handle Bolt	1
10	**STD571207	Roll Pin	1	23	969252-001	Clamper - A	1
11	969156-001	Rod	1	24	969147-002	Pin	1
12	610878-003	*Screw (1/4-20 x 5/8 in. Button Hd.)	2	25	**STD600803	*Screw (8-32 x 3/8 in. Pan Hd.)	2
				27	969150-001	Plate	1
				28	969145-008	Front Block	1

* Standard Hardware Item — May Be Purchased Locally **Available From Division 98 — Source 980.00

CRAFTSMAN 10 in. TABLE SAW – MODEL NO. 315.228110

FIGURE D: BLADE GUARD ASSEMBLY

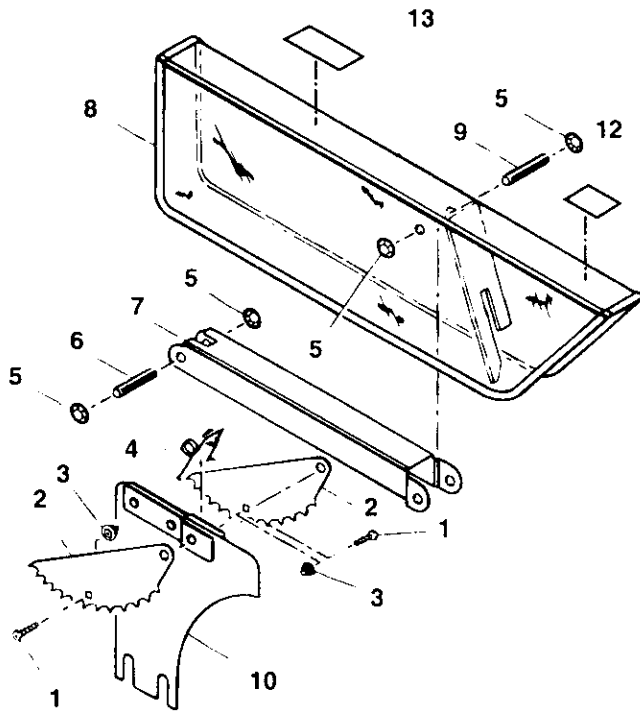

Key Part No.	Number	Description	Quan.
1	968700-004	*Screw (#6-19 x 5/16 in. Pan Hd.)	2
2	969169-001	Anti-kickback Fingers	2
3	662002-001	Spacer Cap	2
4	969608-001	Torsion Spring	1
5	969233-010	Push Nut	4
6	969170-001	Dowel Pin	1
7	969610-002	Arm	1
8	969612-001	Cover (clear)	1
9	969170-002	Dowel Pin	1
10	969168-005	Riving Knife Assembly	1
12	980400-001	Label	1
13	980324-001	Label	1

*Standard Hardware Item — May Be Purchased Locally

FIGURE E: REPLACEMENT PARTS

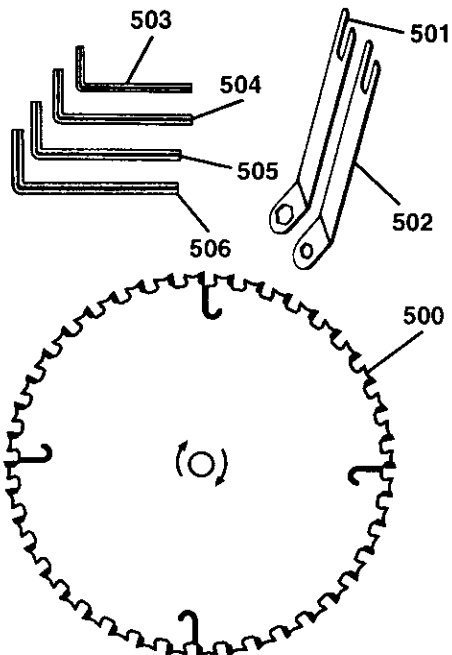

Key Part No.	Number	Description	Quan.
500	663022-001	Saw Blade	1
501	969244-003	Large Wrench	1
502	969244-004	Small Wrench	1
503	9-28134	* 3/32 in. Hex Key	1
504	9-28135	* 1/8 in. Hex Key	1
505	9-28137	* 3/16 in. Hex Key	1
506	9-28136	* 5/32 in. Hex Key	1

*Standard Hardware Item — May Be Purchased Locally

CRAFTSMAN 10 in. TABLE SAW – MODEL NO. 315.228110

The model number will be found on a plate attached to the side panel of the cabinet. Always mention the model number in all correspondence regarding your **TABLE SAW** or when ordering repair parts.

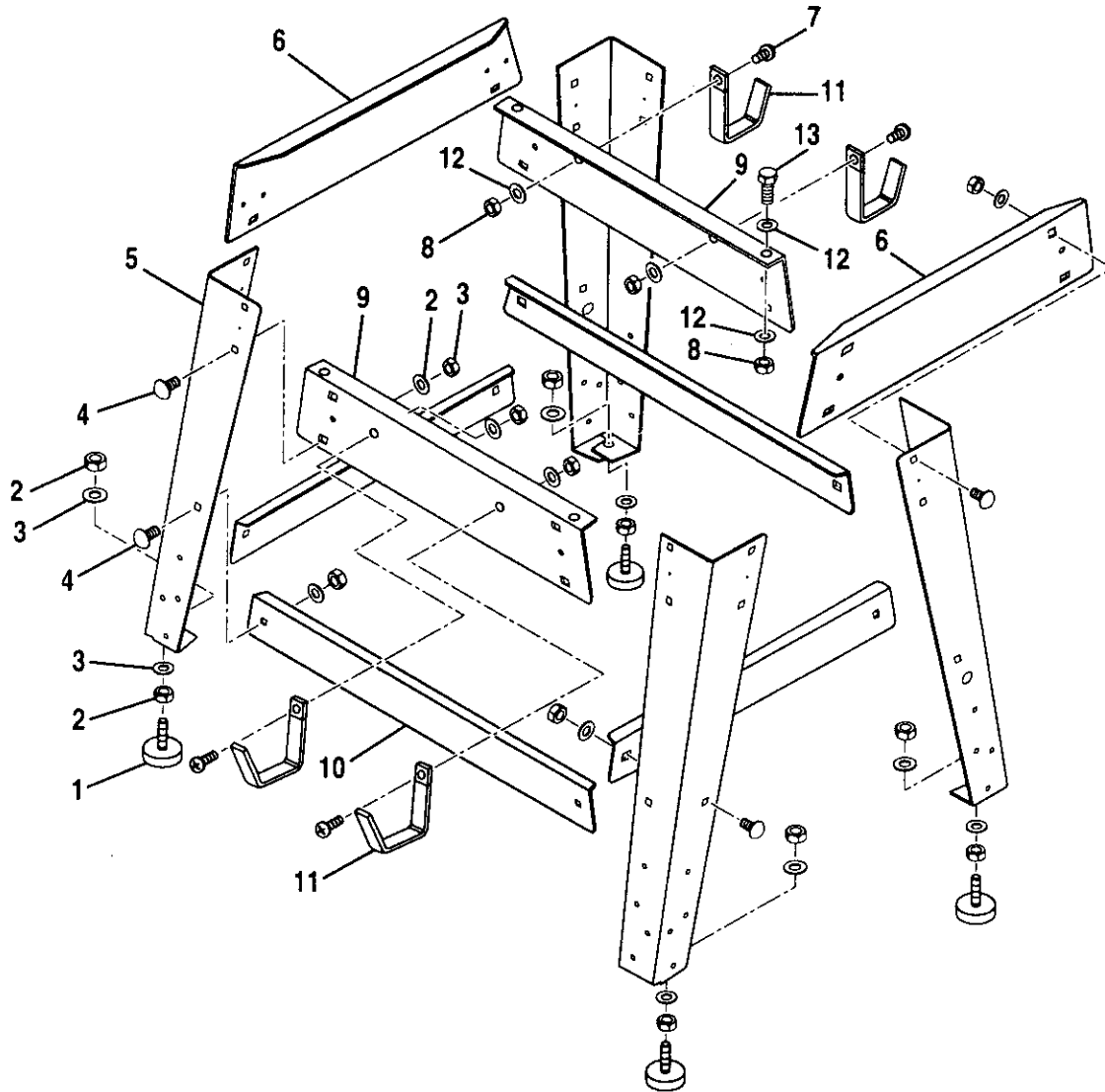

FIGURE F

CRAFTSMAN 10 in. TABLE SAW – MODEL NO. 315.228110

The model number will be found on a plate attached to the side panel of the cabinet. Always mention the model number in all correspondence regarding your **TABLE SAW** or when ordering repair parts.

PARTS LIST FOR FIGURE F

KEY NO.	PART NUMBER	DESCRIPTION	QUAN.
1	979999-001	Leveling Foot.....	4
2	** STD541031	* Hex Nut (5/16-18)	32
3	** STD551031	* Washer (5/16 in.).....	32
4	** STD533107	* Carriage Bolt (5/16-18 x 3/4 in.).....	24
5	979995-001	Leg	4
6	979997-001	Upper Brace	2
7	** STD512505	* Screw (1/4-20 x 1/2 in. Pan Hd.).....	4
8	** STD541425	* Hex Nut (1/4-20)	8
9	981816-001	Upper Side Brace	2
10	979998-001	Lower Leg Brace	4
11	981818-001	Storage Bracket	4
12	** STD551025	* Washer (1/4 in.).....	12
13	** STD522507	* Bolt (1/4-20 x 3/4 in. Hex Hd.)	4
	972000-713	Owner's Manual	

* Standard Hardware Item — May Be Purchased Locally
 ** Available From Div. 98 — Source 980.00

**In U.S.A. or Canada
for in-home major brand repair service:**

Call 24 hours a day, 7 days a week

1-800-4-MY-HOMESM (1-800-469-4663)

Para pedir servicio de reparación a domicilio – 1-800-676-5811

Au Canada pour tout le service ou les pièces – 1-800-469 4663

For the repair or replacement parts you need:

Call 6 a.m. – 11 p.m. CST, 7 days a week

Parts DirectSM

1-800-366-PART (1-800-366-7278)

Para ordenar piezas con entrega a domicilio – 1-800-659-7084

For the location of a Sears Service Center in your area:

Call 24 hours a day, 7 days a week

1-800-488-1222

To purchase or inquire about a Sears Maintenance Agreement:

Call 7 a.m. – 5 p.m. CST, Monday – Saturday

1-800-827-6655



Free Manuals Download Website

<http://myh66.com>

<http://usermanuals.us>

<http://www.somanuals.com>

<http://www.4manuals.cc>

<http://www.manual-lib.com>

<http://www.404manual.com>

<http://www.luxmanual.com>

<http://aubethermostatmanual.com>

Golf course search by state

<http://golfingnear.com>

Email search by domain

<http://emailbydomain.com>

Auto manuals search

<http://auto.somanuals.com>

TV manuals search

<http://tv.somanuals.com>