

SEARS

OWNERS MANUAL

MODEL NO.
315.23743

Serial
Number _____

Model and serial number
may be found on plate at
motor end cap.

You should record both
model and serial number in
a safe place for future use.

CAUTION:
Read Rules for
Safe Operation
and Instructions
Carefully

SAVE THIS
MANUAL FOR
FUTURE REFERENCE

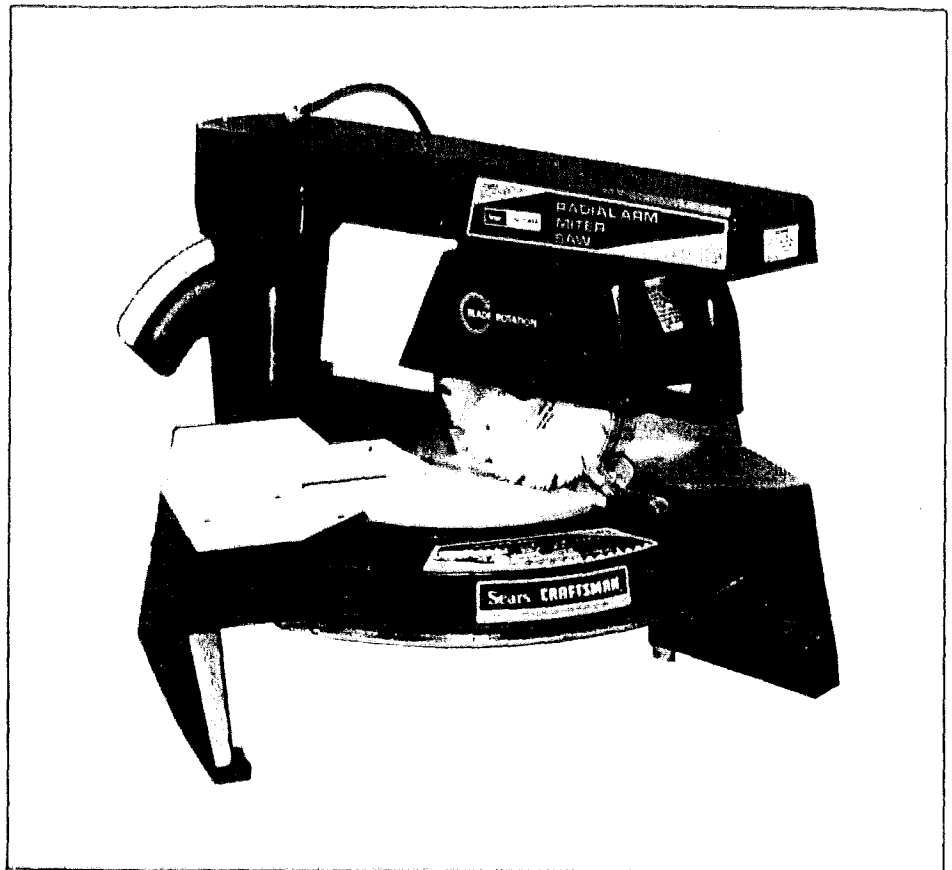

CRAFTSMAN[®]

7 1/2 INCH RADIAL ARM MITER SAW

DOUBLE INSULATED WITH MECHANICAL BRAKE

Introduction
Assembly
Operation
Maintenance
Repair Parts



Sold by SEARS, ROEBUCK AND CO., Dept. 698/731A, Sears Tower, Chicago, IL 60684
612547-228

PRINTED IN U.S.A

FULL ONE YEAR WARRANTY ON CRAFTSMAN RADIAL ARM MITER SAW

If within one year from the date of purchase, this Craftsman Radial Arm Miter Saw falls due to a defect in material or workmanship, Sears will repair it, free of charge.

WARRANTY SERVICE IS AVAILABLE BY SIMPLY CONTACTING THE NEAREST SEARS STORE OR SERVICE CENTER THROUGHOUT THE UNITED STATES.

This warranty gives you specific legal rights, and you may also have other rights which vary from state to state.

SEARS ROEBUCK AND CO.
698/731A
SEARS TOWER
CHICAGO, IL 60684

INTRODUCTION

DOUBLE INSULATION is a concept in safety, in electric power tools, which eliminates the need for the usual three wire grounded power cord and grounded supply system. Wherever there is electric current in the tool there are two complete sets of insulation to protect the user. All exposed metal parts are isolated from the internal metal motor components with protecting insulation.

IMPORTANT — Servicing of a tool with double insulation requires extreme care and knowledge of the system and should be performed only by a qualified service technician. For service we suggest you return the tool to your nearest Sears Store for repair. Always use original factory replacement parts when servicing.

RULES FOR SAFE OPERATION

WARNING — DO NOT ATTEMPT TO OPERATE UNTIL YOU HAVE READ THOROUGHLY AND UNDERSTAND COMPLETELY ALL INSTRUCTIONS, RULES, ETC. CONTAINED IN THIS MANUAL. FAILURE TO COMPLY CAN RESULT IN ACCIDENTS INVOLVING FIRE, ELECTRIC SHOCK, OR SERIOUS PERSONAL INJURY. SAVE OWNERS MANUAL AND REVIEW FREQUENTLY FOR CONTINUING SAFE OPERATION, AND INSTRUCTING POSSIBLE THIRD-PARTY USER.

READ ALL INSTRUCTIONS

- 1. KNOW YOUR POWER TOOL** — Read owner's manual carefully. Learn its applications and limitations as well as the specific potential hazards peculiar to this tool.
- 2. GUARD AGAINST ELECTRICAL SHOCK BY PREVENTING BODY CONTACT WITH GROUNDED SURFACES.** For example: Pipes, radiators, ranges, refrigerator enclosures.
- 3. KEEP GUARDS IN PLACE** and in working order.
- 4. REMOVE ADJUSTING KEYS AND WRENCHES.** Form habit of checking to see that keys and adjusting wrenches are removed from tool before turning it on.
- 5. KEEP WORK AREA CLEAN.** Cluttered areas and benches invite accidents.
- 6. DON'T USE IN DANGEROUS ENVIRONMENT.** Don't use power tool in damp or wet locations or expose to rain. Keep work area well lit. Never use in explosive atmosphere. Normal sparking of motor could ignite fumes.
- 7. KEEP CHILDREN AWAY.** All visitors should be kept safe distance from work area.
- 8. MAKE WORKSHOP KID-PROOF** with padlocks, master switches, or by removing starter keys.

RULES FOR SAFE OPERATION (Continued)

9. **DON'T FORCE TOOL.** It will do the job better and safer for which it was designed.
10. **USE RIGHT TOOL.** Don't force tool or attachment to do a job it was not designed for.
11. **WEAR PROPER APPAREL.** No loose clothing, gloves, neckties, rings, bracelets, or other jewelry to get caught in moving parts. Non-slip footwear is recommended. Wear protective hair covering to contain long hair. Roll long sleeves above elbow.
12. **ALWAYS USE SAFETY GLASSES.** Also use face or dust mask if cutting operation is dusty. Everyday glasses only have impact resistant lenses, they are **NOT** safety glasses.
13. **SECURE WORK.** Use clamps or a vise to hold work. It's safer than using your hand and it frees both hands to operate tool.
14. **DON'T OVERREACH** — Keep proper footing and balance at all times.
15. **MAINTAIN TOOLS WITH CARE** — Keep tools sharp and clean for best and safest performance. Follow instructions for lubricating and changing accessories. Always use a clean cloth when cleaning. Never use brake fluid, gasoline, or any strong solvents to clean your tool.
16. **DISCONNECT TOOLS** — Before servicing and when changing accessories such as blades, bits, cutters, etc., all tools should be disconnected.
17. **AVOID UNINTENTIONAL STARTING** — Make sure switch is in off position before plugging in cord.
18. **USE RECOMMENDED ACCESSORIES** — Consult the owners manual for recommended accessories. The use of improper accessories may cause hazards.
19. **NEVER STAND ON TOOL** — Serious injury could occur if the tool is tipped or if the cutting tool is accidentally contacted.
20. **CHECK DAMAGED PARTS** — Before further use of the tool, a guard or other part that is damaged should be carefully checked to ensure that it will operate properly and perform its intended function — check for alignment of moving parts, binding of moving parts, breakage of parts, mounting, and any other conditions that may affect its operation. A guard or other part that is damaged should be properly repaired or replaced.
21. **DIRECTION OF FEED** — When cutting, always pull blade into material from rear to front of saw. Never push blade into material from front to rear. Wrong feed direction could result in material kick-back causing serious personal injury.
22. **NEVER LEAVE TOOL RUNNING UNATTENDED. TURN POWER OFF.** Don't leave tool until it comes to a complete stop.
23. **DRUGS, ALCOHOL, MEDICATION.** Do not operate tool under the influence of drugs, alcohol or any medication.

RULES FOR SAFE OPERATION (Continued)

24. **OUTDOOR USE EXTENSION CORDS** — When tool is used outdoors, use only extension cords suitable for use outdoors. Outdoor approved cords are marked with the suffix W-A, for example — SJTW-A or SJOW-A.
25. **DON'T** — Place either hand in the cutting area when the saw is connected to the electrical power supply. Accidental starting could result in serious personal injury.
26. **DON'T — FORCE CUTTING ACTION.** Stalling or partial stalling of motor can cause major damage. Allow motor to reach full speed before cutting.
27. **DON'T** — Use blades recommended for operation at less than 5500 RPM or of a diameter not recommended. The use of improper blades may cause hazardous operating conditions.
28. **DON'T** — Attempt to cut small pieces. Injury could result from improper control or clamping of such material.
29. **DON'T** — Wedge anything against fan to hold motor shaft. This action will cause serious damage to the saw motor.
30. **DO** — Make certain the blade rotates in the correct direction. Incorrect rotation will cause material "Kickback" and possible serious injury to operator.
31. **DO** — Keep saw blade sharp and properly set to avoid blade cracking and grabbing, possibly resulting in a serious accident.
32. **DANGER:** A coasting cutting tool can be dangerous. To avoid possible serious injury, apply brake immediately after completion of cut.
33. **ALWAYS** use identical replacement parts when servicing.
34. **WEAR EYE PROTECTION.**
35. **KEEP HANDS OUT OF PATH OF SAW BLADE.**
36. **DO NOT OPERATE SAW WITHOUT GUARDS IN PLACE.**
37. **DO NOT PERFORM ANY OPERATION FREEHAND.**
38. **NEVER REACH AROUND SAW BLADE.**
39. **SHUT OFF POWER AND WAIT FOR SAW BLADE TO STOP BEFORE SERVICING OR ADJUSTING TOOL.**
40. **WARNING: TO REDUCE THE RISK OF INJURY, RETURN SAW HEAD TO THE FULL REAR POSITION AFTER EACH CROSSCUT OPERATION.**
41. This tool is intended for residential use only.
42. **SAVE THESE INSTRUCTIONS.**



The operation of any miter saw can result in foreign objects being thrown into the eyes, which can result in severe eye damage. Always wear safety goggles complying with ANSI Z87.1 (shown on Package) before commencing power tool operation. Safety Goggles are available at Sears Catalog Order or Retail Stores.

TABLE OF CONTENTS

Unpacking.....	5	Securing Workpiece.....	11-12
Mounting of Miter Saw.....	6	Typical Operations.....	12-16
Assembly.....	6	Maintenance.....	18-21
Adjustments.....	7-9	Trouble Shooting.....	22
Operating Instructions.....	10-11	Illustration and Parts List.....	25-31
Table Extension and		How to Order Repair Parts.....	32

TOOLS NEEDED FOR ASSEMBLY AND ADJUSTMENT

Your miter saw can be assembled and adjusted with a few basic hand tools shown below:



7/16" AND 1/2" WRENCHES



BLADE WRENCH (FURNISHED)



MEDIUM SCREWDRIVER

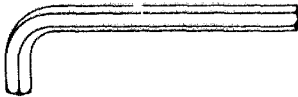

3/16" ALLEN WRENCH
(FURNISHED)



PHILLIPS SCREWDRIVER

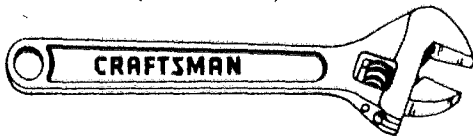

8" ADJUSTABLE WRENCH

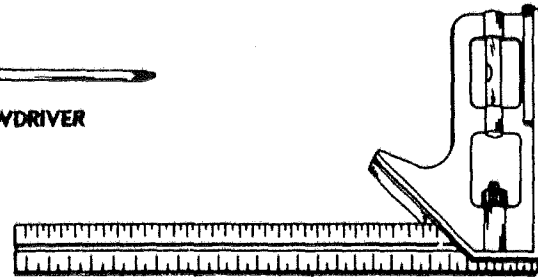

COMBINATION SQUARE

UNPACKING

1. Remove the miter saw from the carton by lifting it by the miter saw table. See Figure 1. **CAUTION:** When removing the miter saw do not lift by the operating handle or the saw arm as this may cause misalignment.
2. Remove the two hex nuts and washers and lift the miter saw off the cardboard pad.
3. Your miter saw is shipped with the saw head locked both in the rear position and the 45° miter setting. To release the saw head, unlock by turning the lock lever counter-clockwise. This will allow the saw head to move forward for operating positions. Move the saw head through its entire movement, front to rear, several times to check for binding. Should saw head bind in its movement, make adjustment as follows: See Fig. 1
 1. Move saw head to full rear position.
 2. Using allen wrench furnished, loosen screw (A) on front guide rod clamp, one half turn.
 3. Move saw head through its entire movement, front to rear several times, stopping it in the front position.
 4. Move the saw head slightly to the rear and tighten screw (A) securely.
 5. Recheck for any binding in saw head movement.

Should binding still be present after adjusting, return the saw to your nearest Sears retail store. See Page 11 for operating instructions of miter arm.

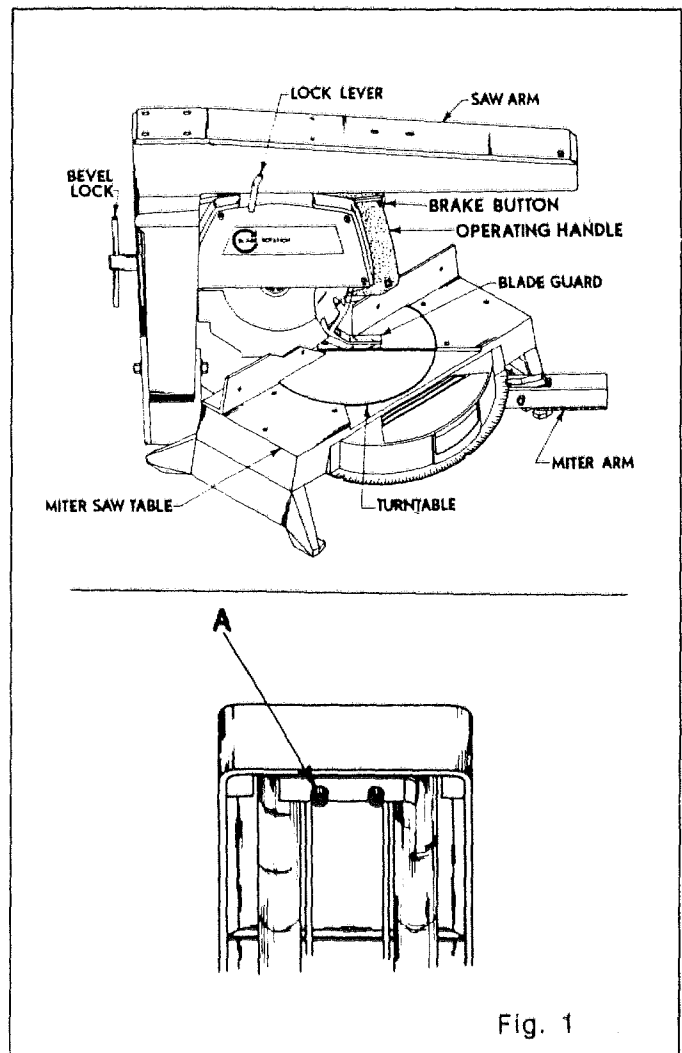

Fig. 1

FASTENING MITER SAW TO WORKBENCH OR LEG SET (9-22246)

DISCONNECT MITER SAW FROM POWER SUPPLY

If the miter saw is to be used in a permanent location, it should be fastened securely to a firm supporting surface such as a workbench or accessory leg set (9-22246). It is recommended that the saw be mounted so that the saw table is approximately 39" above the floor. However, for your convenience and safety you might require a different height. In all cases care must be taken to assure operator visibility of cutting area. Holes should be drilled through supporting surface of the workbench as illustrated in Figure 2. Each leg of the miter saw should be bolted securely using 5/16" diameter machine bolts, 5/16" hex nuts, and lock washers. Bolts should be of sufficient length to accommodate legs of miter saw, washers, hex nuts, and thickness of supporting surface. Tighten all four bolts securely. If the saw is to be used in a portable application, it is recommended that it be fastened to a mounting board. The board should be of sufficient size to avoid tipping of saw while in use. Any good grade of plywood or chipboard with a 3/4" minimum thickness is recommended. Mount saw to board using hole pattern as shown in Figure 2 and described above. Clamp board securely to workbench.

SECURING WORKBENCH AND LEGS TO FLOOR

DISCONNECT MITER SAW FROM POWER SUPPLY
The supporting surface where miter saw is mounted should be examined carefully after mounting to insure that no movement during use can result. If any "tipping" or "walking" is noted, secure workbench legs, or supporting surface before operating.

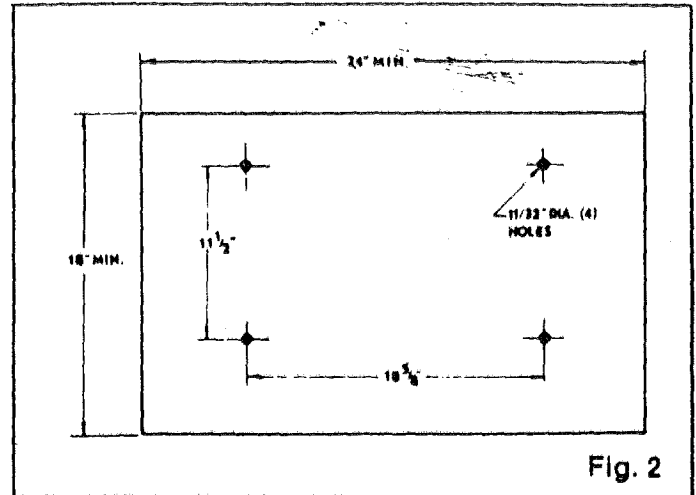

Fig. 2

EXTENSION CORDS

The use of any extension cord will cause some loss of power. To keep the loss to a minimum and to prevent tool overheating, follow the recommended cord sizes on the chart below. When tool is used outdoors, use only extension cords identified as suitable for outdoor use. Extension cords are available at Sears Catalog Order or Retail Stores.

Extension Cord Length	Wire Size A.W.G.
25-50 Feet	16
50-100 Feet	14

WARNING: CHECK EXTENSION CORDS BEFORE EACH USE. IF DAMAGED, REPLACE IMMEDIATELY. NEVER USE TOOL WITH A DAMAGED CORD SINCE TOUCHING THE DAMAGED AREA COULD CAUSE ELECTRICAL SHOCK RESULTING IN SERIOUS INJURY.

ASSEMBLY

CAUTION: NEVER USE A BLADE ON THIS MITER SAW THAT IS RATED LESS THAN 5500 R.P.M. AND IT MUST BE 7-1/2 INCHES IN DIAMETER. NEVER USE A BLADE HAVING A THICKNESS THAT WILL NOT ALLOW OUTER BLADE WASHER TO ENGAGE WITH FLAT ON SPINDLE.

DISCONNECT MITER SAW FROM POWER SUPPLY. BLADE ASSEMBLY

- Place saw head in the position shown in Fig. 3. Remove four screws (A) and blade cover (B).
- Remove blade screw (C), spring washer (D), and outer blade washer (E) from the spindle. **NOTE: THE BLADE SCREW HAS LEFT-HAND THREADS.**
- Fit the saw blade inside the guards and over the spindle WITH THE BLADE TEETH AT THE BOTTOM POINTED TO THE REAR.
- REPLACE THE OUTER BLADE WASHER MATCHING FLAT SIDE OF "D" HOLE OF WASHER WITH FLAT SIDE OF SPINDLE. SEE FIG. 3. REPLACE SPRING WASHER AND BLADE SCREW AND TIGHTEN FINGER TIGHT. NOTE: THE BLADE SCREW HAS LEFT-HAND THREADS. CAUTION: "D" HOLE IN THE OUTER BLADE WASHER MUST BE ALIGNED WITH AND ENGAGED ON THE FLAT SIDE OF THE SPINDLE TO PREVENT THE BLADE FROM COMING OFF THE SPINDLE.**
- With a soft wood block seated on the turntable (F) and in front of the fence (G), move the saw head until the blade teeth embed in the block and hold securely. With the wrench furnished, hand tighten the blade screw until no further tightening can be accomplished.

Remove blade wrench from blade screw, and

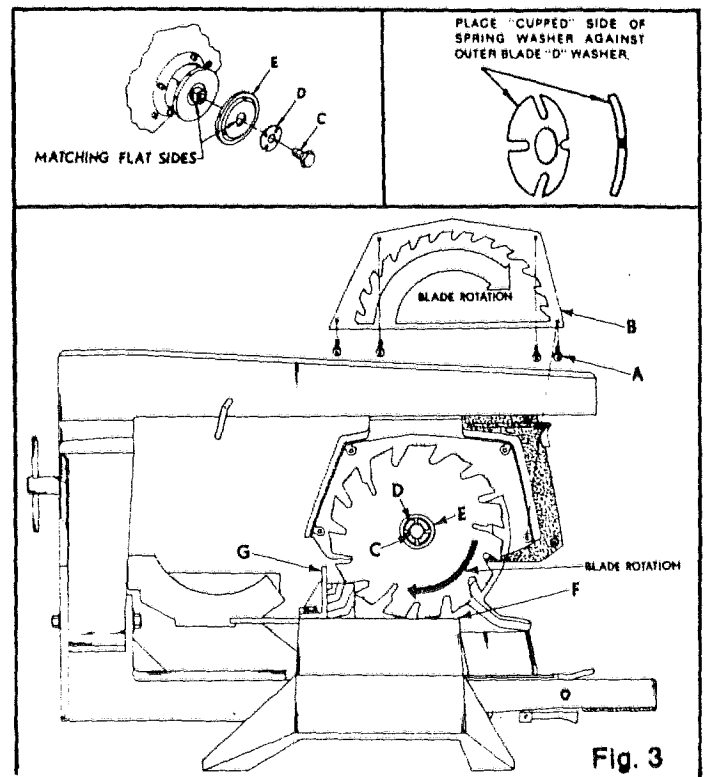

Fig. 3

ADJUSTMENTS

Your miter saw has been factory adjusted and aligned to assure proper operation. However, misalignment can occur during shipping. All alignments must be checked to assure that factory settings have been maintained. **NO ADJUSTMENTS SHOULD BE MADE BEFORE CHECKING THESE ALIGNMENTS.** For your convenience the checks and adjustments should be made in the following order.

DISCONNECT MITER SAW FROM POWER SUPPLY.

BEVEL ADJUSTMENT

1. Place saw head in position shown in Fig. 4.
2. Place square firmly against table as shown and check blade squareness. If blade is square with table check pointer (A) for 0° setting, adjust pointer if needed by loosening screw (B), locate pointer on 0°, and tighten screw. If blade is not square with table proceed as follows:
3. Loosen lock screw (C) slightly in order to pivot saw arm (D).
4. Adjust saw arm until blade is square with table and tighten lock screw securely.
5. Set pointer to 0° as stated in 2 above.
6. Reassemble blade cover and four screws as shown in Fig. 3. It is not necessary to remove blade cover for any further checks or adjustments. **COVER SHOULD ALWAYS BE IN PLACE DURING SAW OPERATION.**

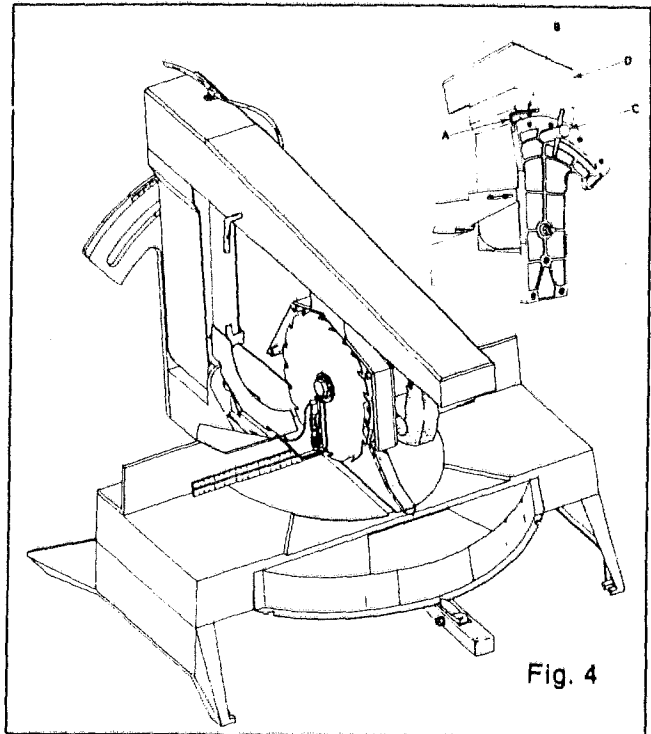

Fig. 4

CAUTION: BEFORE MAKING FURTHER CHECKS OR ADJUSTMENTS CONNECT MITER SAW TO POWER SUPPLY AND MOMENTARILY ENGAGE SWITCH TO CHECK FOR CORRECT DIRECTIONAL ROTATION OF BLADE. SEE FIG. 3. IF INCORRECT ROTATION IS DISCOVERED, DO NOT USE THIS SAW. RETURN IT TO YOUR NEAREST SEARS RETAIL STORE.

DISCONNECT MITER SAW FROM POWER SUPPLY BLADE CENTERING ADJUSTMENT

NOTE: The design of this saw requires that the blade be slightly off set to the right of the turntable slot. See Fig. 5.

It is now necessary to visually check the blade alignment with the center of the turntable slot. See Fig. 5.

1. Place miter arm at 0° setting with detent lever (A) fully engaged in slot.
2. Tighten locking lever (B) securely.
3. With saw head centered on turntable as shown, visually check or measure to assure that the blade is closely centered on turntable slot. If satisfactory proceed to next adjustment check. If setting is not proper, make adjustment as follows:
4. Using allen wrench furnished, slightly loosen four cap screws (C) located in the top rear of the saw arm.
5. With the palm of the hand tap to left or right, as required, the front of the saw arm (D) until the bottom of the saw blade is centered as described in item 3 above.
6. Tighten the four cap screws (C) securely.

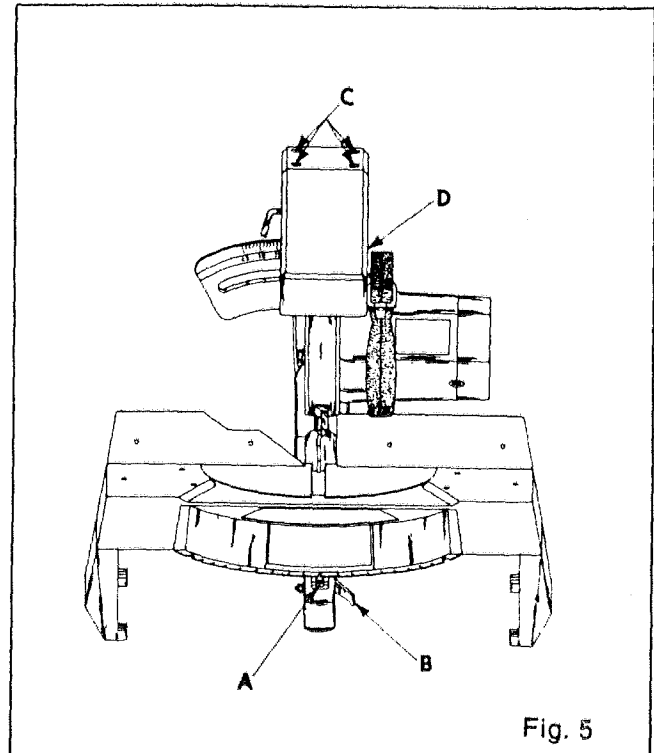

Fig. 5

ADJUSTMENTS (Continued)

DISCONNECT MITER SAW FROM POWER SUPPLY

BLADE HEEL ADJUSTMENT

The saw blade must be aligned, front to rear, with the direction of travel of the saw head. This condition is referred to as Blade Heel. See Fig. 6.

1. Miter arm must be securely locked at 0° setting as described above. (See Blade Centering Adjustment, item 1 and 2.)
2. With the rear edge of the saw blade set in line with the left fence, hold the blade of your square firmly against the top front face of the fence.
3. Move the blade of your square to the right until its end lightly touches the side of the saw blade. Hold square firmly and push the saw head slowly to the rear allowing the saw blade to pass by the end of the square until the front edge of saw blade is in line with the end of the square. Note any clearance or interference at the front edge of saw blade, with the end of the square, in order to determine direction of any saw head adjustment. If the blade has the same clearance to the square through entire saw head movement, no adjustment is necessary. Proceed to next adjustment check.
4. Should misalignment have been found, make adjustments as follows:
5. Move the saw head so that two cap screws (A) located in the traveler (B) are directly under two holes (C) in the top of the saw arm (D).
6. With the allen wrench furnished, slightly loosen both screws. Adjust saw head by lightly tapping front or rear of the motor housing in the direction needed to align the saw blade.
7. Repeat checking procedure as described in 2 and 3 alternating with adjustment described in 6 until all blade heel is removed. Tighten the two cap screws (A) securely. NOTE: WHEN TIGHTENING SCREWS CARE SHOULD BE TAKEN NOT TO CAUSE HEEL SETTING TO CHANGE. Final check should be made as described in 2 and 3 to assure that proper setting has been maintained while tightening screws.

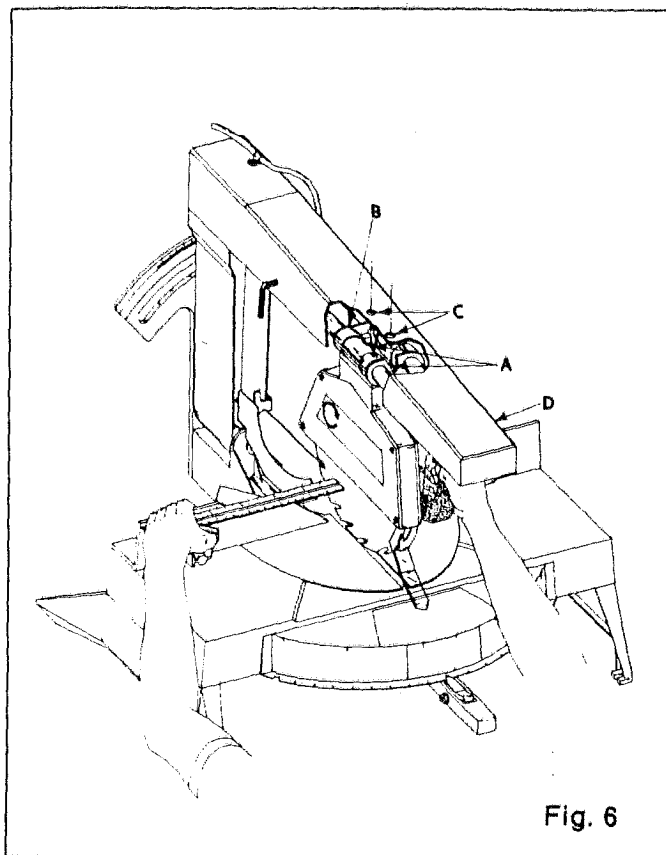

Fig. 6

DISCONNECT MITER SAW FROM POWER SUPPLY

FENCE TO BLADE ADJUSTMENT

To assure proper 45° miter and 90° cross cuts it is necessary to maintain the proper fence to blade setting.

1. With the miter arm locked in the 0° setting as previously described (see Blade Centering Adjustment, page 7, items 1 and 2) place square against left fence and blade as shown in Fig. 7.
2. If fence checks square to blade proceed to next adjustment check. If setting is improper, make left fence adjustment as follows:
3. Loosen two screws on rear of left fence.
4. Adjust left fence square with the blade and securely tighten two screws.
5. Recheck squareness.

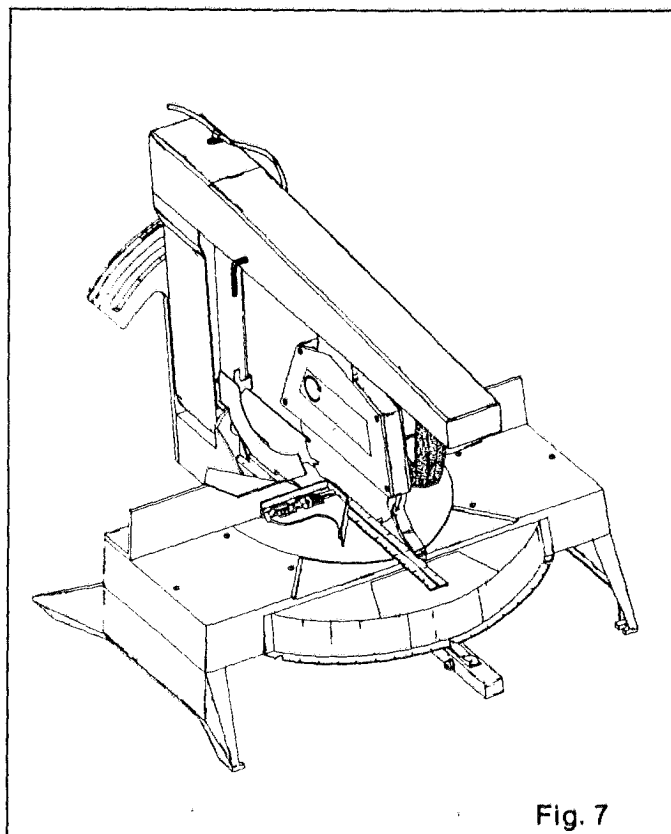

Fig. 7

ADJUSTMENTS Continued

DISCONNECT MITER SAW FROM POWER SUPPLY FENCE TO FENCE ADJUSTMENT

After the left fence has been squared to the blade, or any adjustments made to the left fence, it is necessary to align the right fence. See Fig. 8.

1. Place saw head in full rear position.
2. Locate blade of square along front of both fences. If fences align to each other make no adjustments and proceed to next alignment check. If fences do not align proceed as follows:
3. Loosen two screws on rear of right fence.
4. Using blade of square align right fence with left.
5. Tighten screws securely.

DISCONNECT MITER SAW FROM POWER SUPPLY MITER DETENT ADJUSTMENT

A fine adjustment has been provided in the miter detent lever. This is to allow correction of any slight fence to blade squareness error remaining after all other checks and adjustments have been made.

1. Place square against left fence and blade as shown in Fig. 7.
2. If fence checks square to blade no adjustment is necessary. If setting should require adjustment proceed as follows: See Fig. 9.
3. Release locking lever (F) on miter arm. The detent lever must remain in the 0° setting.
4. Loosen nut (C) with 7/16" open end wrench.
5. Adjust blade square to left fence by turning screw (G) with flat screwdriver. Note: While turning screw, head of screw must be kept against miter arm.
6. When blade is square to left fence, hold screw (G) in position while tightening nut (C).

DISCONNECT MITER SAW FROM POWER SUPPLY BLADE GUARD ADJUSTMENT

For operator protection and safety, the lower blade guard must always be in place and operate properly. The front guard arm should raise as the saw head moves to the full rear position and lower itself to the table as the saw head is moved forward. If the guard does this, there is no adjustment necessary and this completes all checks and adjustments. If guard does not operate make adjustment as follows: See Fig. 10.

1. Push saw head to the full rear position and securely tighten lock screw, located on the left side of the saw arm.
2. With a phillips screwdriver, loosen two screws (A) attaching striker guard (B) to bevel post.
3. Raise blade guard arm (C) to 1/4" from top of saw head and hold in position.
4. Slide striker guard (B) as far forward as it will move and tighten two screws (A) securely.
5. Loosen lock screw and move saw head through its entire movement checking for proper blade guard operation.

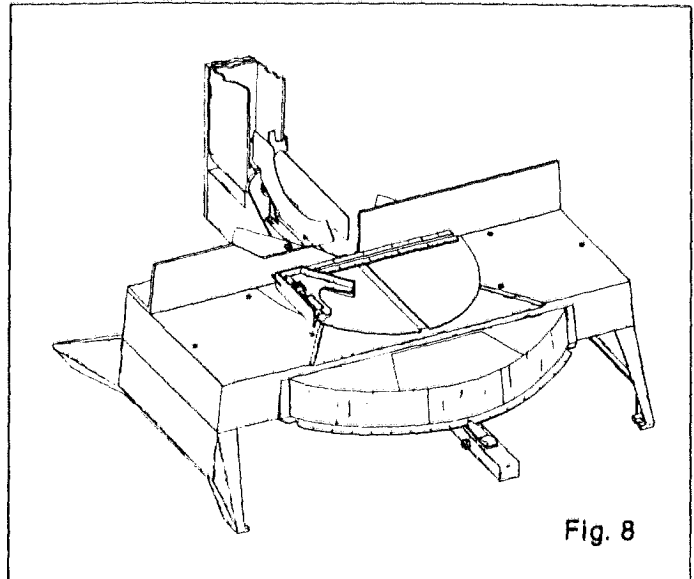

Fig. 8

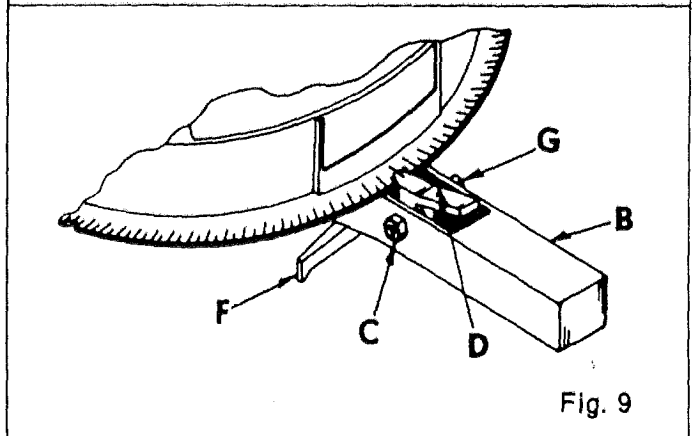

Fig. 9

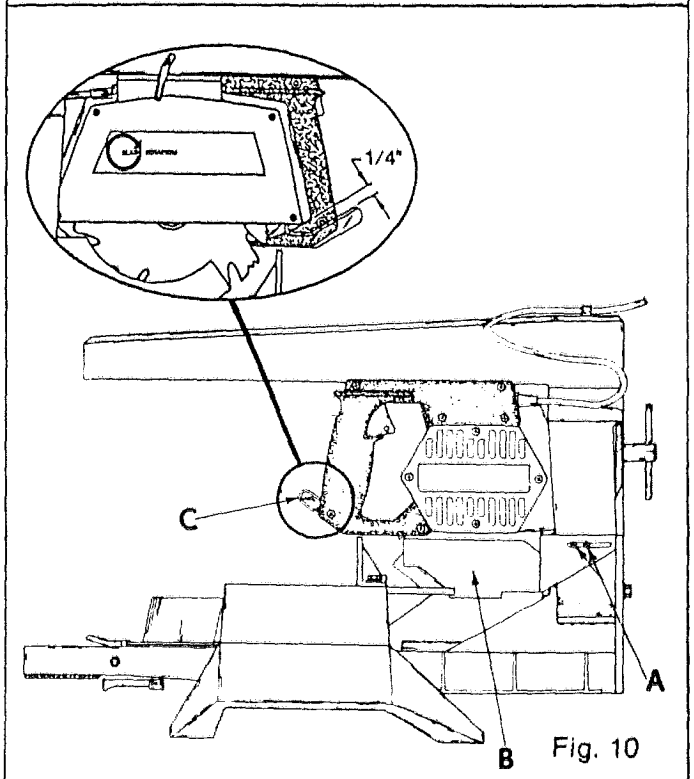

Fig. 10

OPERATION

READ RULES FOR SAFE OPERATION

WARNING: DO NOT ALLOW FAMILIARITY WITH YOUR SAW TO MAKE YOU CARELESS. REMEMBER THAT A CARELESS FRACTION OF A SECOND IS SUFFICIENT TO INFLICT SEVERE INJURY.

Proper positioning of your body and hands when operating your miter saw will make cutting easier and safer. SEE FIGURE 11. NEVER PLACE HANDS NEAR CUTTING AREA. Always stay alert when operating saw — THINK AHEAD AND PREVENT ACCIDENTS. **CAUTION: THE BLADE COVER AND BLADE GUARD ATTACHED TO YOUR SAW ARE THERE FOR YOUR PROTECTION AND SAFETY. THE GUARD COVER SHOULD NEVER BE REMOVED FOR ANY REASON DURING OPERATION.** Should either of these guards become damaged, do not operate the miter saw until the damaged guards are replaced. Always leave guards in operating positions when using saw. Never use miter saw when guards are not operating correctly. Guards should be frequently checked and maintained for proper operation and condition. **NOTE: GUARDS MUST BE IN POSITION OVER BLADE AT ALL TIMES.**

DANGER: REMOVING GUARDS OR IMPROPER OPERATION MAY RESULT IN INJURY.

When making a cut hold the operating handle with your right hand so you can operate the switch trigger with your right index finger. Always stand directly in line with the miter arm and not the base of the saw when making a cut. **DANGER: ALWAYS KEEP HANDS CLEAR OF CUTTING AREA.** When a 45° miter cut is required the miter arm must be moved to that position. **DO NOT STAND IN FRONT OF THE SAW TABLE. MOVE WITH THE MITER ARM TO THE 45° ANGLE.**

STARTING AND STOPPING SAW

To start the saw, depress switch trigger, See Fig. 12. Allow blade to reach full speed and slowly pull blade into material to be cut. **CAUTION: Always clamp material securely against fence and table AND USE SLOW, STEADY PULL ON SAW HEAD TO AVOID BLADE BINDING IN MATERIAL AND POSSIBLE PERSONAL INJURY.** Your miter saw is equipped with a mechanical blade brake. As soon as the cut is completed, release the switch trigger and depress the brake button. Firmly hold the brake button in the depressed position until the blade stops its rotation. **CAUTION: BLADE SHOULD COME TO A COMPLETE STOP BEFORE RETURNING SAW HEAD TO REAR POSITION.** To prevent possible damage to your saw, never engage switch while brake button is depressed.

WARNING: TORQUE DEVELOPED DURING THE BRAKING PROCESS MAY CAUSE THE BLADE SCREW TO WORK LOOSE. TO AVOID THE POSSIBILITY OF AN ACCIDENT RESULTING IN POSSIBLE SERIOUS INJURY, PERIODICALLY CHECK AND TIGHTEN BLADE SCREW.

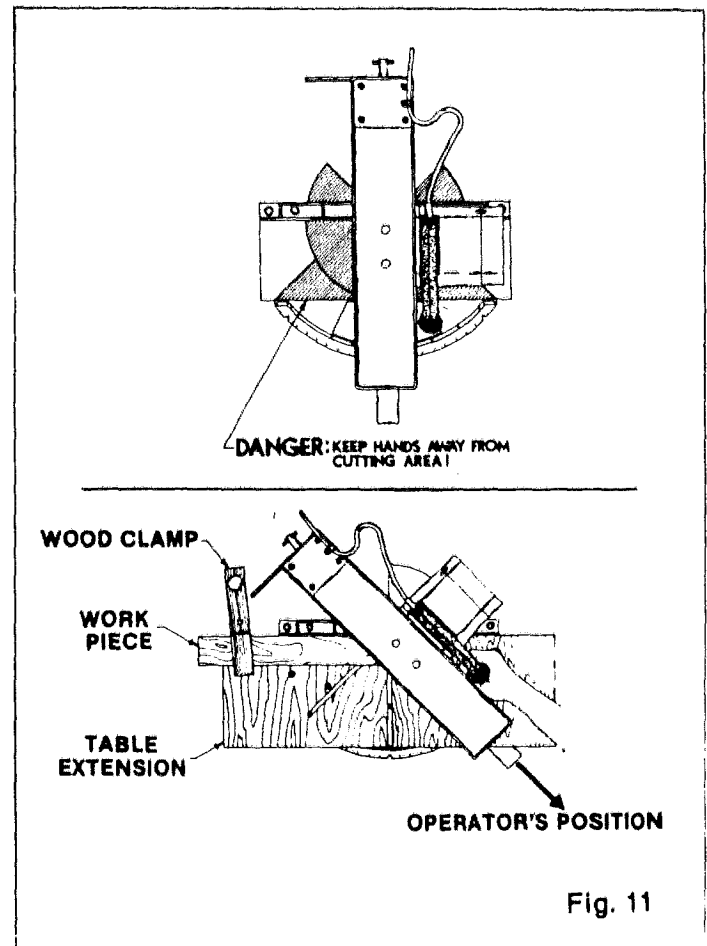

Fig. 11

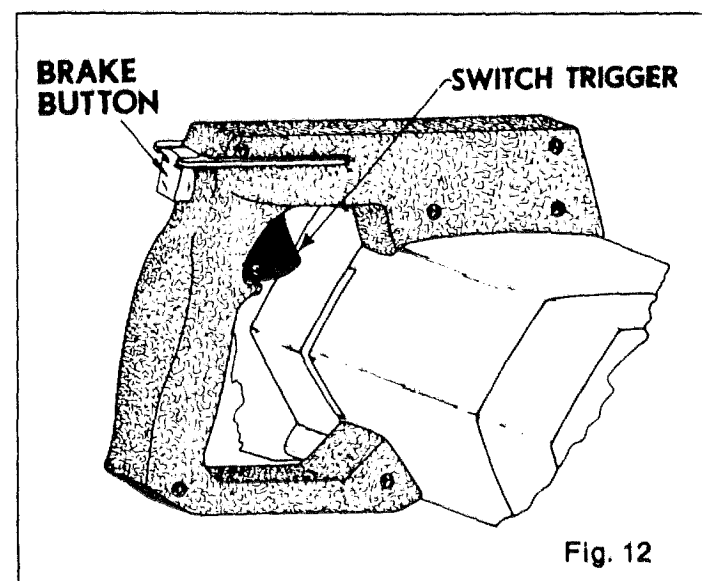
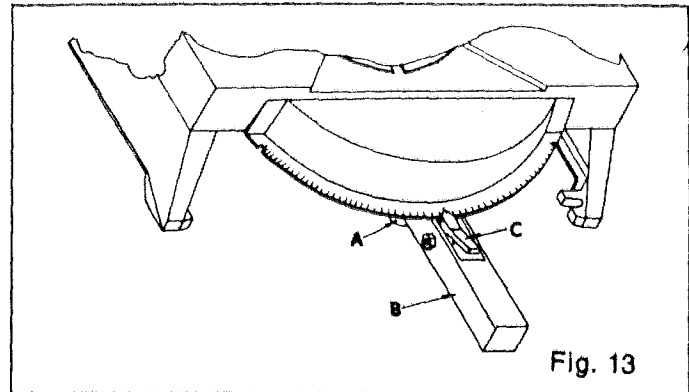

Fig. 12

OPERATION (Continued)

OPERATION OF MITER ARM

Your miter saw will cut any angle from 0° to 47-1/2° left and right. To operate miter arm release lock lever (A) on underside of miter arm (B) by turning counterclockwise. See Figure 13. Depress detent lever (C), move miter arm to desired angle, and tighten lock lever (A). Your miter saw also has positive stops at 0° and 45° left and right. When any of these cuts are desired release lock lever (A) on underside of miter arm (B). Release detent lever (C) and move miter arm to desired angle. The spring loaded positive stop engages in the indent automatically.



OPERATION OF BEVEL POST

Your miter saw is also capable of making bevel cuts from 45° to 90°. To operate bevel post, loosen lock screw (A) as shown in Fig. 14 and pivot saw arm until the pointer (B) is on desired bevel angle. Tighten lock screw securely. Note: While adjusting bevel post, care should be taken to hold saw arm and saw head securely to prevent sudden fall to the 45° position and possibly damaging your saw.

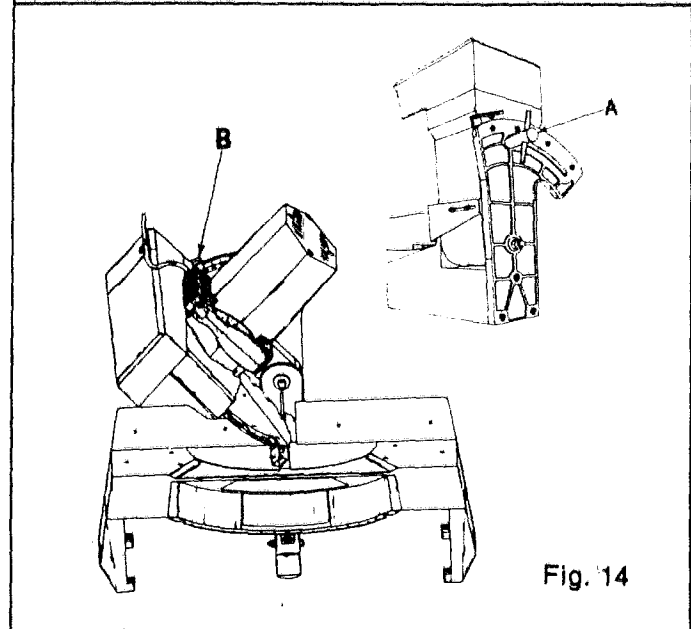
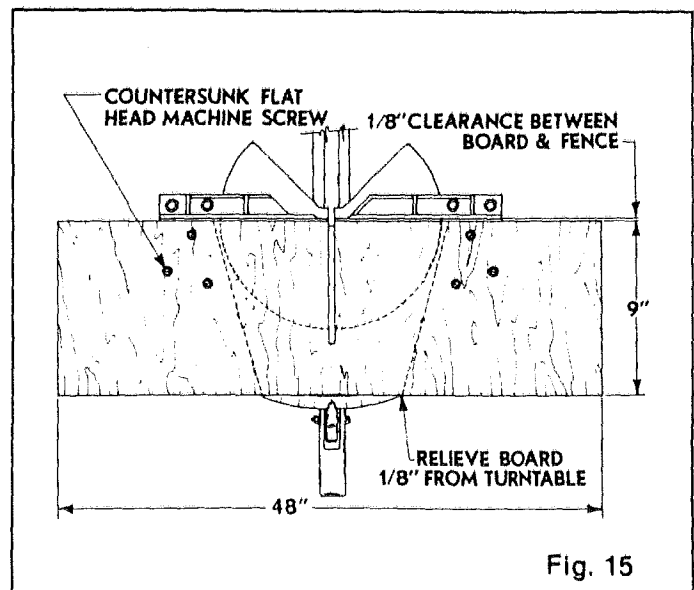

TABLE EXTENSION AND SECURING WORKPIECE

Caution: Due to inherent dangers from using this type of saw, especially during miter and compound angle cutting, it is strongly recommended that table extensions and material clamps be used to avoid possible serious injury to operator.

To construct a table extension it is suggested that a 1/2" thick x 9" wide x 48" long straight, solid board be used. See Fig. 15. The bottom surface of the board must be relieved 1/8" in the area of the turntable to permit rotation of the miter arm. Attach the board to the miter saw table, according to the illustration shown, using six (6) 1/4-20 x 1" long counter-sunk flat head machine screws. All screw heads must be recessed below the top surface of the board. After assembly of the board to the table, make a clearance cut into the board with the miter arm and/or bevel post at the setting to be used. **NOTE:** The usable height of the fence as well as the thickness cutting capacity of saw will be reduced by the thickness of the table extension board. **CAUTION:** Screw heads must clear blade in all cutting positions of miter arm and bevel post.



Materials should always be positioned with their widest side against the table extension.

TABLE EXTENSION AND SECURING WORKPIECE (Continued)

Because of the possibility of the material being cut causing the saw blade to jam or feed itself into the material, and possibly causing serious personal injury to the operator, **CLAMPS SHOULD ALWAYS BE USED TO SECURE MATERIALS TO THE TABLE EXTENSION DURING CUTTING.** This eliminates any need for the operators hands to be used in the cutting area of the saw. Wooden glue clamps or metal 'C' clamps are recommended for this purpose and are available at your nearest Sears store or catalog center. These clamps must be of sufficient size to securely hold the material during cutting. After the desired saw settings are made for the required cut, the material should be placed on the table extension, properly located in relation to the blade, and pushed firmly against the fences. See Fig. 16. When the material has been properly positioned the clamp must be located and tightened to securely hold the material to the table extension.

CAUTION: BECAUSE OF POSSIBLE SERIOUS PERSONAL INJURY TO THE OPERATOR, MATERIAL NOT LONG ENOUGH TO BE SECURELY CLAMPED TO TABLE EXTENSION SHOULD NOT BE CUT WITH THIS SAW.

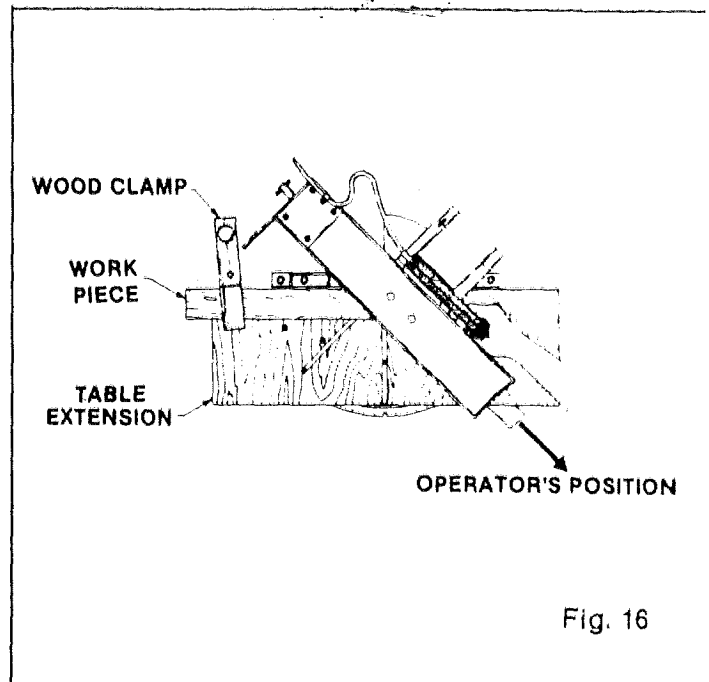

Fig. 16

To prevent material bow and possible saw blade jamming in the material, long lengths of material must be supported at some distance from the saw. See Fig. 17. The support should be strong enough to properly hold the material being cut and located at the same height as the table or extension.

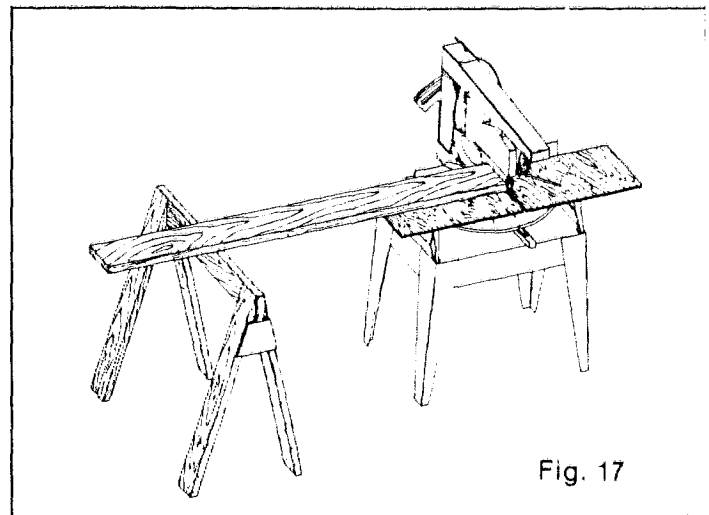

Fig. 17

TYPICAL OPERATIONS

Your Craftsman Radial Arm miter saw was designed to cut wood and plastics. It is not recommended for cutting ferrous metals or hard non-ferrous alloys. Shown below are just some of the many operations that may be performed with your miter saw. As you become more familiar with the operation of your saw you will find many more uses. Always use proper blade for material being cut. The blade packed with your miter saw was designed to cut wood.

The cutting capacity of your saw depends upon the setting at which the cut is being made. The saw will cut material 9-7/8" wide at 0° miter setting and 7-3/8" wide at 45° miter setting. Your miter saw will also cut material 2-3/8" thick at 0° bevel setting and 1-5/8" thick at 45° bevel setting. Care should be taken prior to cutting of any material to assure that it is not too wide or thick for the angle being cut.

CAUTION: To prevent possible personal injury, you should read and understand all items shown under "Table Extension and Securing Workpiece" before attempting any cutting with this saw.

Securely tighten both the bevel and miter arm locking screws before making any cut and return the saw head to the full rear position when cuts are complete, and after the blade has stopped rotating.

TYPICAL OPERATIONS (Continued)

CUTTING MOULDINGS

You can cut 45° miter cuts on material and moldings up to 2-3/8" thick. See Fig. 18. Instead of making right and left hand 45° cuts for matching miters, or cornering, simply make the 45° cut and for the matching face turn the work completely over and make your cut with the saw at the same setting. Your miter saw is also capable of cutting angles up to 47-1/2° to allow the operator to compensate for existing out of square corners. Miters on material such as baseboards that are wider than 2-3/8" should be cut with the material lying flat on the saw table. The miter cut can be made with the bevel post at 45° setting and the miter arm at 0°. Refer to page 21 for proper blades to be used with your materials.

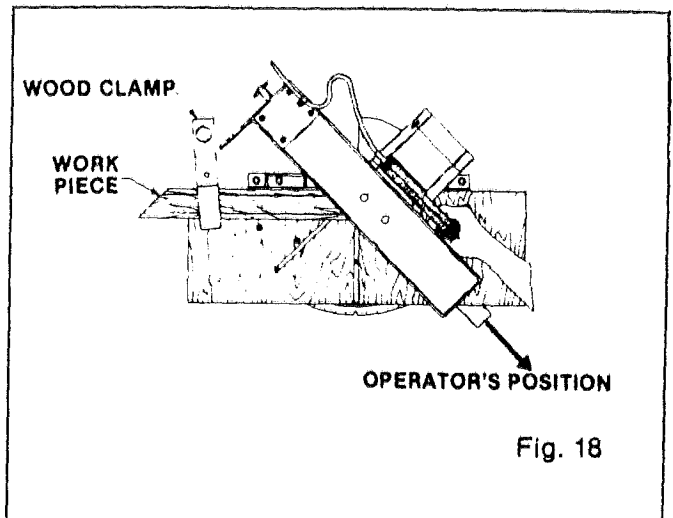

Fig. 18

CUTTING FRAMING MATERIALS

2 x 4 and 2 x 6 framing material as well as moldings can be cut at all angle settings of the miter arm. It is an ideal saw for squaring ends of framing material where random lengths are being used. See Fig. 19. NOTE: Care must be taken to properly support long lengths of material during cutting to avoid possible damage to the miter saw and/or serious injury to operator. See page 21 for proper blade for your cutting requirement.

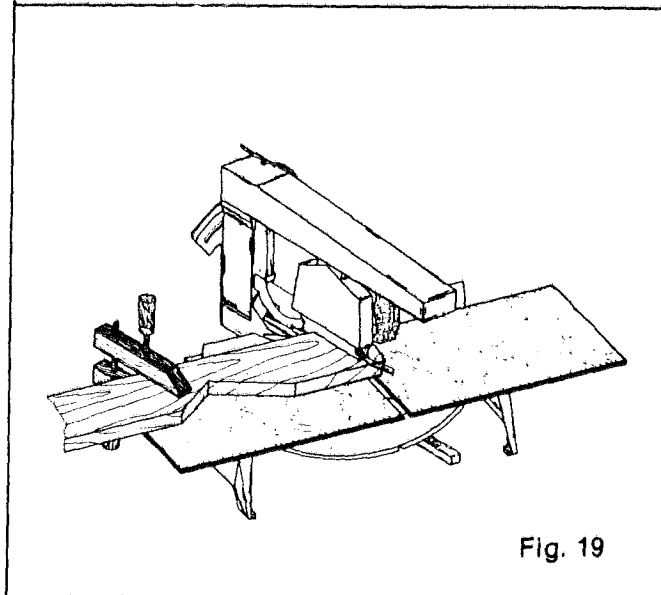

Fig. 19

CUTTING ROOF RAFTERS

With this saw it is possible to make compound angle cuts using required settings of both the miter arm and the bevel post. See Fig. 20. Ends of roof rafters, for joining with hip roof ridge and valley rafters, can be readily cut to proper angles. With the material laying flat on the saw table and firmly against fences, set the miter arm for the correct pitch angle and the bevel post for the correct intersect angle. The resulting cut will give an excellent fitting rafter end. NOTE: After cut is completed, release the switch trigger, depress the brake button to stop rotation of blade. Then remove the material from the saw table before returning saw head to rear position. This prevents the blade guard from binding on the material when returning saw head to rear position. Again care should be used to properly support long lengths of material. See Fig. 17. NOTE: Table extension and clamp are not used when making this cut. WARNING: Keep hands clear of cutting area.

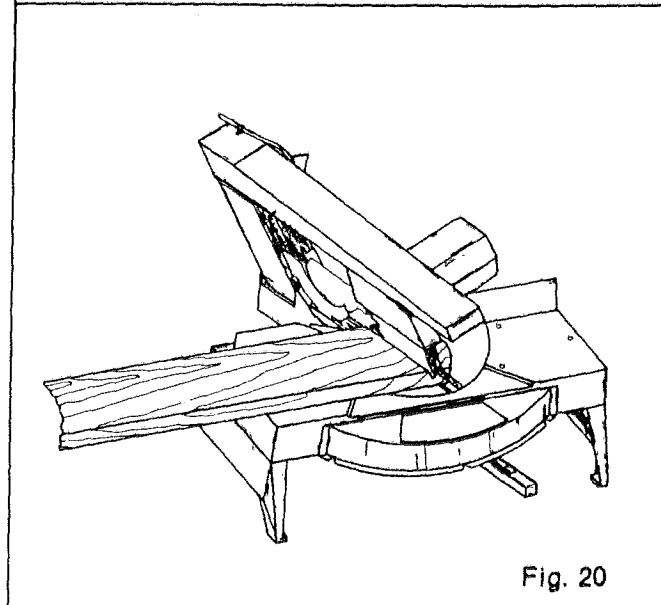

Fig. 20

TYPICAL OPERATIONS (Continued)

CUTTING THIN MATERIALS

Your miter saw can be used for cutting thin materials such as laminated plastics and composition board. See Fig. 21. To avoid jamming under the fences all thin materials should only be cut when the saw is equipped with a table extension and material is securely clamped. See "Table Extension and Securing Workpiece" as shown on page 11. For proper blade requirements, see page 21.

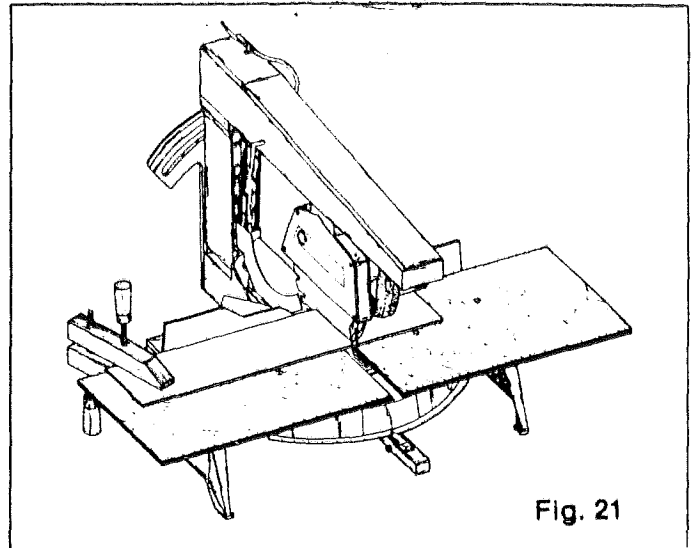

Fig. 21

CUTTING PLASTIC PIPE

You can use your miter saw on plastic pipe. It makes clean, square ends for butt joining and mitered ends for cornering. Care must be taken to properly clamp pipe during cut to prevent its rotation. See Fig. 22. Long material should also be supported at saw table height for ease of cutting and to avoid possible injury to the operator. See "Table Extension and Securing Workpiece", page 11. See page 21 for the correct blade to use on the material to be cut.

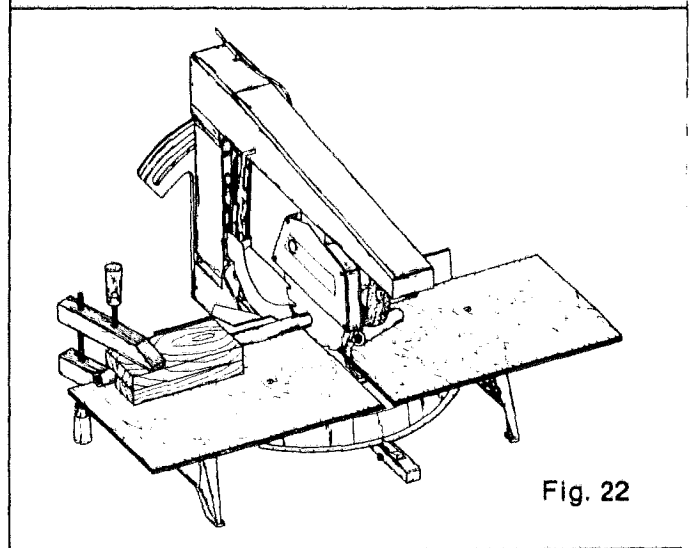

Fig. 22

WARNING: DUE TO THE POSSIBILITY OF CAUSING PERSONAL INJURY TO THE OPERATOR AND DAMAGING YOUR SAW, ONLY THOSE BLADES AND ACCESSORIES LISTED ON PAGE 21 SHOULD BE USED WITH THIS SAW. THIS SAW WAS NOT DESIGNED FOR USE WITH DADOES, MOLDING HEADS, SANDING DISCS OR CUT-OFF WHEELS, AND THESE MUST NEVER BE USED WITH IT. REMEMBER, READ AND UNDERSTAND ALL INSTRUCTIONS, USE YOUR SAW CAREFULLY, AND PREVENT INJURIES.

CUTTING BOWED MATERIAL

When cutting any material, check to make sure it is not bowed. If it is bowed the material must be positioned and cut in the proper manner. Material positioned incorrectly will cause pinching of the blade near the end of the cut. See Fig. 23 for correct positioning of material on miter saw. It also shows incorrect positioning of material which will cause pinching of the blade.

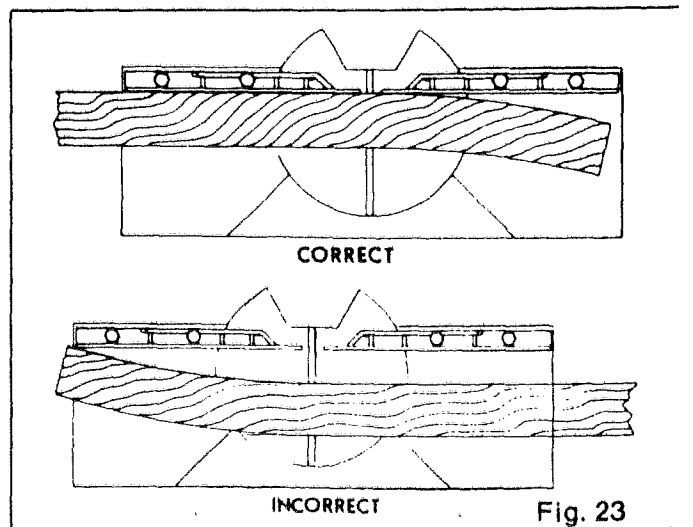

Fig. 23

TYPICAL OPERATIONS (Continued)

CUTTING POLYGON MITERS

Any closed construction has a number of sides which must be joined together at the proper angles. This can be done with either a miter or bevel setting of the correct angle and the material lying with the flat side against the saw table. See Fig. 24. Flat miters, as shown, can be cut with a miter arm setting, but miters to be used with the material on edge must be cut with the bevel post at the proper setting. See table in Fig. 25 for proper angle setting of either the miter arm or bevel post to create your desired cuts. For an object requiring a number of sides not shown in the table, a simple formula of 180° divided by the number of sides in the object results in the miter arm degree setting for each cut. See Page 12 for cutting capacity of your saw for this type of cut.

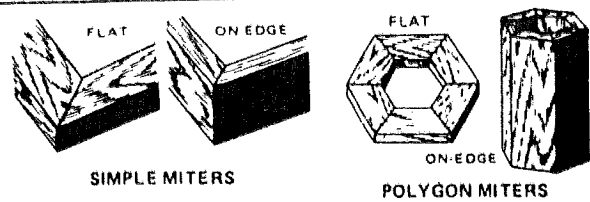

Fig. 24

EXAMPLES

NO. SIDES	ANGLE MITER OR BEVEL
4	45°
5	36°
6	30°
7	25.7°
8	22.5°
9	20°
10	18°

Fig. 25

CUTTING CROWN MOULDING

The majority of crown mouldings have contact surfaces of 52° and 38° on the top and bottom rear surfaces, and in some instances are wider than the cutting capacity of the saw. Because of this, it is much easier to cut crown moulds for square corners with the material lying flat on its back surface and a compound setting on the saw. See Fig. 26. In all cases the bevel post should be set at 33.85° and the miter arm set at 31.62° either right or left, depending on the desired cut. Your saw angle quadrants are graduated in $1/2^\circ$ ($.50^\circ$). Care should be taken in making set-ups to properly adjust saw settings to decimal degrees. Excellent corner fits should be obtained with these settings. However, angle settings cannot be relied upon to be precise. Always test angle setting accuracy on scrap and plan each cut before you begin.

OUTSIDE CORNER

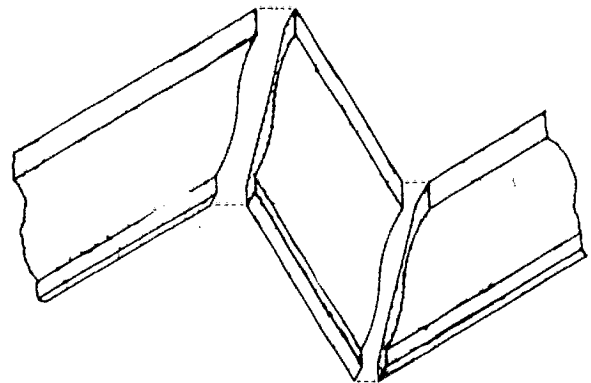

INSIDE CORNER

Fig. 26

CUTTING COMPOUND MITERS

A compound miter, sometimes called a hopper or bevel miter, is a cut utilizing both a miter and bevel setting on the same cut. It is used for making frames or boxes with sloping sides (see Fig. 27) and for certain roof framing cuts (see "Cutting Roof Rafters"). To make this type cut, the miter arm must be adjusted to the correct angle and the bevel post tilted the correct amount. Care should always be taken when making compound miter set-ups due to the interaction of the two angle settings. After the first setting is made, miter or bevel post, adjusting the second setting will change the first. Because of this, angles previously set should always be checked after a setting of the second angle. Repeat as required until the two correct settings for your particular cut are obtained. See Page 12 for cutting capacity of your saw for this type of cut. NOTE: After cut is completed release the switch trigger, depress the brake button to stop rotation of blade. Then remove the material from the saw table before returning saw head to rear position. This prevents the blade guard from binding on the material when returning saw head to rear position.

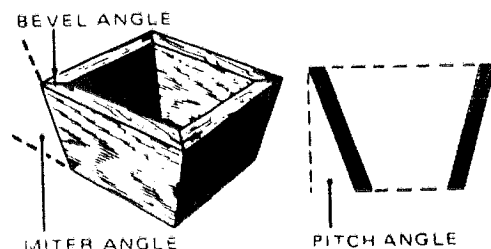

COMPOUND MITER

Fig. 27

TYPICAL OPERATIONS (Continued)

CUTTING COMPOUND MITERS (Cont'd)

To aid in making the correct settings, the compound angle setting chart shown in Fig. 28 has been provided. Since compound cuts are the most difficult to accurately obtain, trial cuts should be made in scrap material, and much thought and planning made, prior to making your required cut.

PITCH OF SIDE	NUMBER OF SIDES						
	4	5	6	7	8	9	10
0°	M-45.00° B- 0.0°	M-36.00° B- 0.0°	M-30.00° B-00.0°	M-25.71° B- 0.0°	M-22.50° B- 0.0°	M-20.00° B- 0.0°	M-18.00° B- 0.0°
5°	M-44.89° B- 3.53°	M-35.90° B- 2.94°	M-29.91° B- 2.50°	M-25.63° B- 2.17°	M-22.42° B- 1.91°	M-19.93° B- 1.71°	M-17.94° B- 1.54°
10°	M-44.56° B- 7.05°	M-35.58° B- 5.86°	M-29.62° B- 4.98°	M-25.37° B- 4.32°	M-22.19° B- 3.81°	M-19.72° B- 3.40°	M-17.74° B- 3.08°
15°	M-44.01° B-10.55°	M-35.06° B- 8.75°	M-29.15° B- 7.44°	M-24.95° B- 6.45°	M-21.81° B- 5.68°	M-19.37° B- 5.08°	M-17.42° B- 4.59°
20°	M-43.22° B-14.00°	M-34.32° B-11.60°	M-28.48° B- 9.85°	M-24.35° B- 8.53°	M-21.27° B- 7.52°	M-18.88° B- 6.72°	M-16.98° B- 6.07°
25°	M-42.19° B-17.39°	M-33.36° B-14.38°	M-27.62° B-12.20°	M-23.58° B-10.57°	M-20.58° B- 9.31°	M-18.26° B- 8.31°	M-16.41° B- 7.50°
30°	M-40.89° B-20.70°	M-32.18° B-17.09°	M-26.57° B-14.48°	M-22.64° B-12.53°	M-19.73° B-11.03°	M-17.50° B- 9.85°	M-15.72° B- 8.89°
35°	M-39.32° B-23.93°	M-30.76° B-19.70°	M-25.31° B-16.67°	M-21.53° B-14.41°	M-18.74° B-12.68°	M-16.60° B-11.31°	M-14.90° B-10.21°
40°	M-37.45° B-27.03°	M-29.10° B-22.20°	M-23.86° B-18.75°	M-20.25° B-16.19°	M-17.60° B-14.24°	M-15.58° B-12.70°	M-13.98° B-11.46°
45°	M-35.26° B-30.00°	M-27.19° B-24.56°	M-22.21° B-20.70°	M-18.80° B-17.87°	M-16.32° B-15.70°	M-14.43° B-14.00°	M-12.94° B-12.62°
50°	M-32.73° B-32.80°	M-25.03° B-26.76°	M-20.36° B-22.52°	M-17.20° B-19.41°	M-14.91° B-17.05°	M-13.17° B-15.19°	M-11.80° B-13.69°
55°	M-29.84° B-35.40°	M-22.62° B-28.78°	M-18.32° B-24.18°	M-15.44° B-20.82°	M-13.36° B-18.27°	M-11.79° B-16.27°	M-10.56° B-14.66°
60°	M-26.57° B-37.76°	M-19.96° B-30.60°	M-16.10° B-25.66°	M-13.54° B-22.07°	M-11.70° B-19.35°	M-10.31° B-17.23°	M- 9.23° B-15.52°
65°	M-22.91° B-39.86°	M-17.07° B-32.19°	M-13.71° B-26.95°	M-11.50° B-23.16°	M- 9.93° B-20.29°	M- 8.74° B-18.06°	M- 7.82° B-16.26°
70°	M-18.88° B-41.64°	M-13.95° B-33.53°	M-11.17° B-28.02°	M- 9.35° B-24.06°	M- 8.06° B-21.08°	M- 7.10° B-18.75°	M- 6.34° B-16.88°
75°	M-14.51° B-43.08°	M-10.65° B-34.59°	M- 8.50° B-28.88°	M- 7.10° B-24.78°	M- 6.12° B-21.69°	M- 5.38° B-19.29°	M- 4.81° B-17.37°
80°	M- 9.85° B-44.14°	M- 7.19° B-35.37°	M- 5.73° B-29.50°	M- 4.78° B-25.30°	M- 4.11° B-22.14°	M- 3.62° B-19.68°	M- 3.23° B-17.72°
85°	M- 4.98° B-44.78°	M- 3.62° B-35.84°	M- 2.88° B-29.87°	M- 2.40° B-25.61°	M- 2.07° B-22.41°	M- 1.82° B-19.92°	M- 1.62° B-17.93°
90°	M- 0.00° B-45.00°	M- 0.00° B-36.00°	M- 0.00° B-30.00°	M- 0.00° B-25.71°	M- 0.00° B-22.50°	M- 0.00° B-20.00°	M- 0.00° B-18.00°

Each B (Bevel) and M (Miter) Setting Is Given to the Closest 0.005°.

COMPOUND-ANGLE SETTINGS FOR POPULAR STRUCTURES

Fig. 28

MAINTENANCE

WHEN SERVICING USE ONLY IDENTICAL REPLACEMENT PARTS

BRUSH REPLACEMENT

DISCONNECT MITER SAW FROM POWER SUPPLY.

1. Remove brush caps (A) from motor housing (B) with screwdriver. See Figure 29.
2. Remove brushes (C).
3. Assemble new brushes into motor housing, making sure that the brushes move freely in the brush tube.
4. Replace the brush caps.
5. After brush replacement is completed saw should be run at no load 3 to 5 minutes to properly seat the brushes.

SWITCH REPLACEMENT

DISCONNECT MITER SAW FROM POWER SUPPLY.

1. Remove the six screws (A) that secure the handle cover and carefully lift it from the tool. Note the locations of all wiring in the handle and how each connection is made to the switch. Connections and wiring position must be identical when installing the new switch.
2. Remove the screw (B) securing the switch (C) and lift the switch away from the handle.
3. Remove the leads from the switch and attach them to the new switch making sure they are attached in proper location as shown in Fig. 30.
4. Arrange the wiring in the handle so that it will not be pinched when the handle cover is replaced and secure switch in place with screw (B).
5. Place the cord and bend relief in their correct locations.
6. Properly locate and seat brake linkage in its proper place making sure linkage does not bind or interfere with wiring.
7. Replace handle cover and tighten all screws.

CORD REPLACEMENT

DISCONNECT MITER SAW FROM POWER SUPPLY.

1. Remove handle cover as described above.
2. Remove switch from handle and disconnect the supply cord leads from the switch.
3. Attach each lead of the new supply cord to the switch in the proper location making sure red lead from motor is attached at this time. See Figure 30.
4. Arrange the wiring in the handle so that it will not be pinched when handle cover is replaced and secure the switch in place. CAUTION: DO NOT PINCH WIRING WITH SCREW BOSSES.
5. Place the bend relief and cord in their correct locations.
6. Properly locate and seat brake linkage in its proper place making sure linkage does not bind or interfere with wiring.
7. Replace handle cover and tighten all screws.

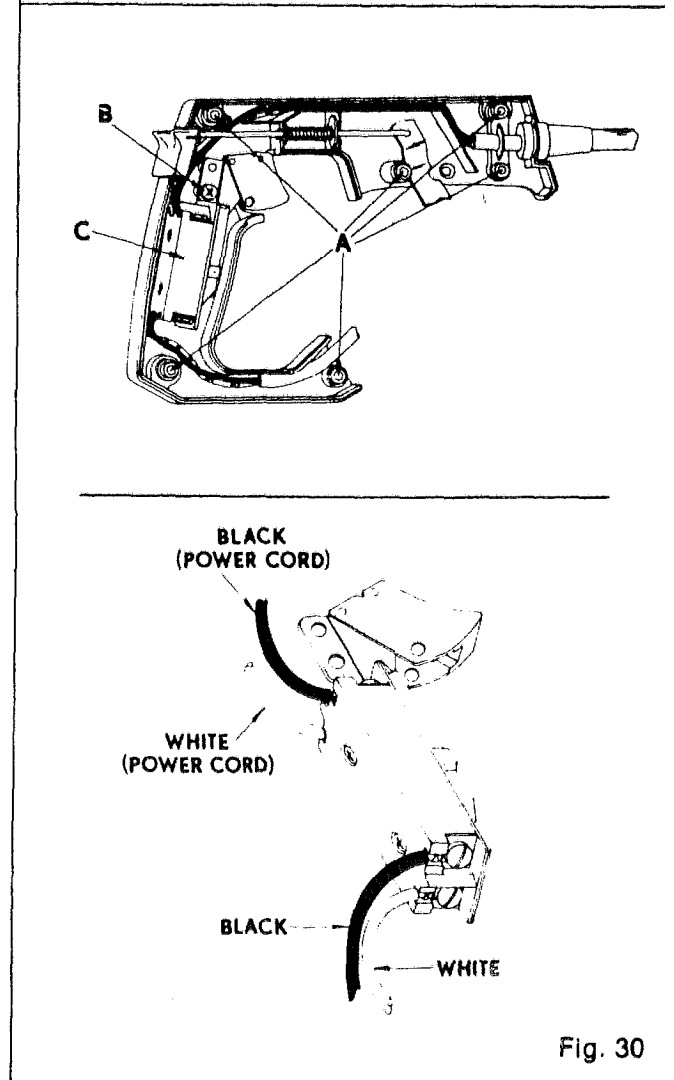
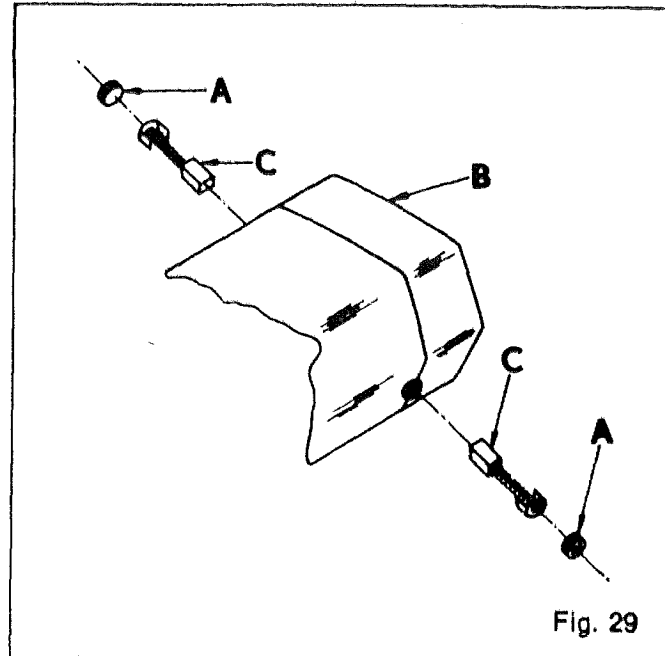

MAINTENANCE (Continued)

REMOVING THE BLADE

DISCONNECT MITER SAW FROM POWER SUPPLY.

1. Place saw head in the position shown in Fig. 31. Remove four screws (A) and blade cover (B).
2. Place a soft wood block on the turntable (F) seated against the front of the fence (G). See Fig. 31. Move the saw head until the blade teeth embed in the block and hold securely.
3. With the wrench furnished loosen the blade screw (C) until it can be removed by hand. **NOTE: THE BLADE SCREW HAS LEFT-HAND THREADS.**
4. Remove the screw (C), spring washer (D), and outer blade washer (E).
5. Remove saw blade from spindle.
6. To assemble blade see Fig. 3, Page 6. Note: Blade cover must always be in place when blade is mounted on unit.

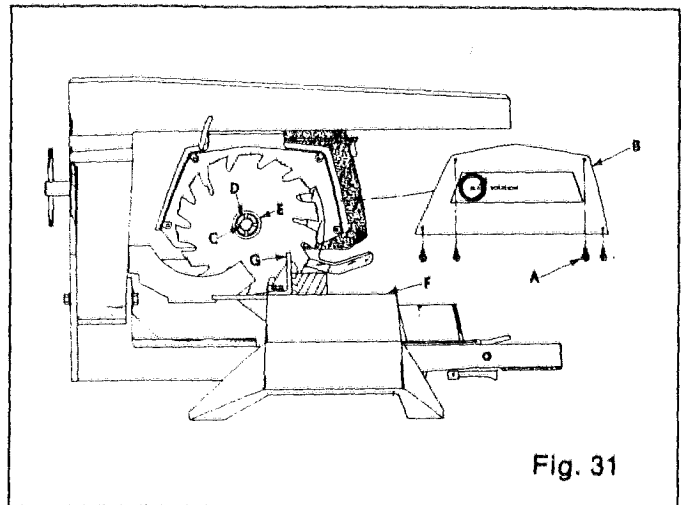

Fig. 31

WHEN NOT IN USE LOCK SWITCH IN THE "OFF" POSITION

IMPORTANT: We suggest that when the miter saw is not in use it should be disconnected from the power supply. The switch should be locked in the "off" position using a padlock, as shown in Figure 32. A lock with a shackle up to 3/16" diameter may be used.

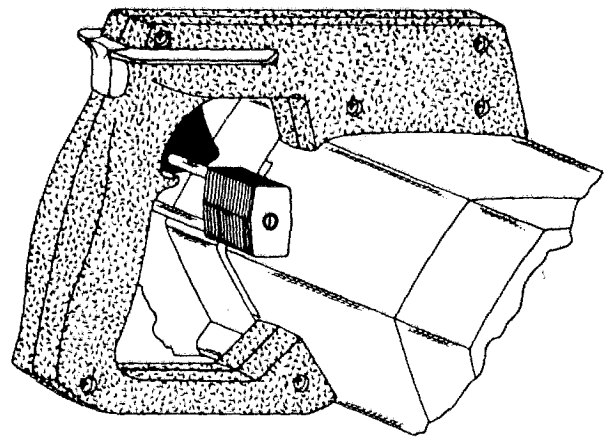

Fig. 32

FOR ADDED SAFETY the saw head should be locked in the rear position when the miter saw is not in use or is being moved. To lock the saw head in the rear position.

DISCONNECT MITER SAW FROM POWER SUPPLY.

1. Push saw head to rear as shown in Fig. 33.
2. Lock saw head in this position by tightening lock lever.

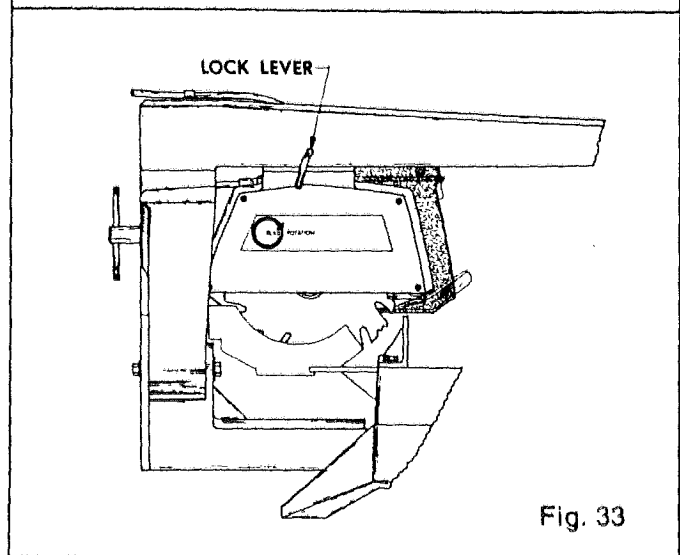

Fig. 33

MAINTENANCE (Continued)

TO CLEAN SAWDUST FROM TURNTABLE

Periodically sawdust will accumulate between the turntable and miter saw table. This will cause difficulty in the movement of the turntable when making different angle cuts. To clean sawdust from between turntable and miter saw table.

DISCONNECT MITER SAW FROM POWER SUPPLY.

1. Remove the blade.
2. Place saw head in the rear position.
3. Clean between miter saw table and turntable. See Fig. 34.
4. Replace blade.

PROPER TENSION OF TURNTABLE

DISCONNECT MITER SAW FROM POWER SUPPLY

Proper tension on turntable should be maintained to help prevent "wobble" in saw arm. To make the adjustment simply loosen or tighten lock nut (A) on pin-tle bolt (B) located on underside of miter arm. See Fig. 35.

LUBRICATION

In order to maintain proper bearing lubrication, your saw arm assembly has an oil reservoir that should be refilled from time to time. SEE FIGURE 36. To refill: Slide saw head along guide rods until the oil reservoir on one end of the traveler lines up with one of the oil holes on top of the saw arm assembly. Add several drops of machine oil. Next, slide saw head along guide rods until the oil reservoir on the other end of the traveler lines up with one of the oil holes on top of the saw arm assembly. Add several drops of machine oil to this side of your traveler also.

MOTOR PLAY ADJUSTMENT

As mentioned earlier, your miter saw has been factory adjusted and aligned to assure proper operation. After use, however, the bearings in the traveler of your saw arm assembly may begin to wear creating motor play. To remove this motor play make the following adjustments.

1. See Figure 37. Move the saw head so that two screw heads (A & B) can be seen thru the 3/8" diameter holes in top of the saw arm assembly.
2. Tighten screw (A) so that the motor will not slide back or forth. Loosen screw (A) just enough so that motor will slide.
3. Adjust screw (B) by the same procedure.
4. Move the saw head forward about 2-1/2" until you see the third screw (C). This screw can be seen thru the right hand 3/8" diameter hole.
5. Adjust screw (C) the same as screws (A) & (B) above.

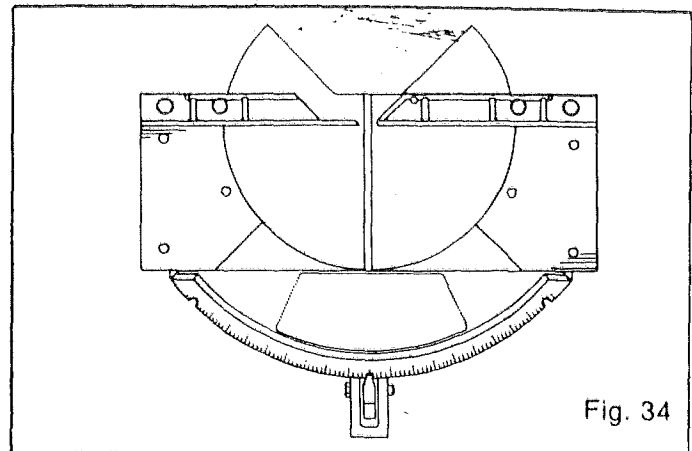
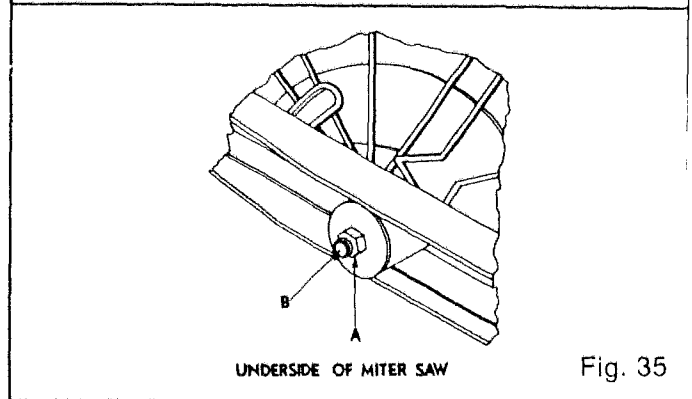

Fig. 34



UNDERSIDE OF MITER SAW

Fig. 35

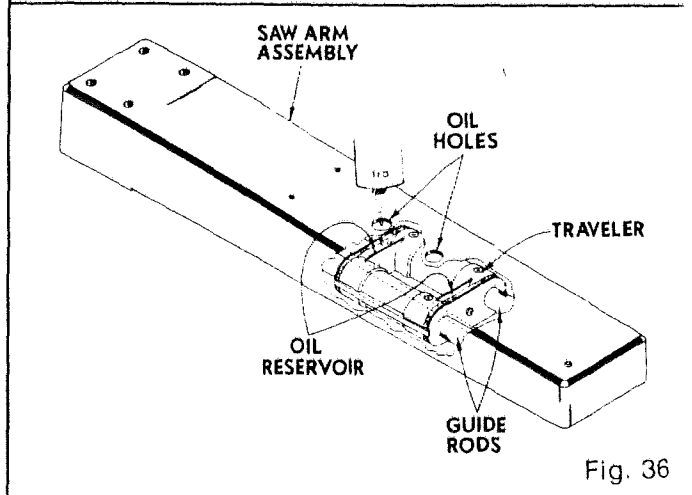

Fig. 36

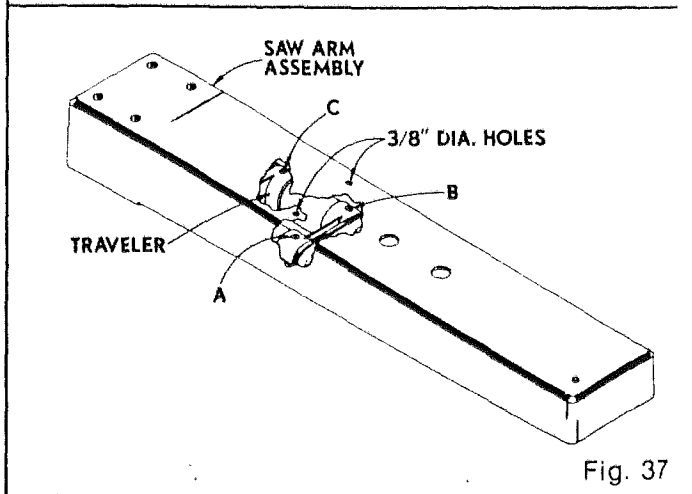

Fig. 37

MAINTENANCE (Continued)

SAW BLADES

The best of saw blades will not cut efficiently if they are not kept clean and sharp. Using a dull blade will do nothing more than place a heavy load on your saw. Keep extra blades on hand, so that sharp blades are always available. Gum and wood pitch hardened on blade will slow it down. Use Craftsman Gum and Pitch Remover No. 9-49191 to remove these accumulations. DO NOT USE GASOLINE. ALWAYS REMOVE BLADE FROM MITER SAW WHEN CLEANING.

GENERAL

Only the parts shown on parts lists, pages 27, 29 and 31 are intended to be repaired or replaced by the customer. All other parts represent an important part of the double insulation system and should be serviced only by a qualified technician.

Avoid using solvents when cleaning plastic parts. Most plastics are susceptible to various types of commercial solvents and may be damaged by their use. Use clean cloths to remove dirt, carbon dust, etc. **WARNING: DO NOT AT ANY TIME LET BRAKE FLUIDS, GASOLINE, PENETRATING OILS, ETC., COME IN CONTACT WITH PLASTIC PARTS. THEY CONTAIN CHEMICALS THAT CAN DAMAGE AND/OR DESTROY PLASTIC.**

When electric tools are used on fiberglass, it has been found that they are subject to accelerated wear and possible premature failure, as the fiberglass chips and grindings are highly abrasive to bearings, brushes, commutators, etc. Consequently it is not recommended that this tool be used for extended work on any fiberglass material. During any use on fiberglass it is extremely important that the tool is cleaned frequently by blowing with an air jet. **ALWAYS WEAR SAFETY GLASSES OR EYE SHIELDS BEFORE BEGINNING THIS OPERATION.**

RECOMMENDED ACCESSORIES

THE FOLLOWING RECOMMENDED ACCESSORIES ARE CURRENT AND WERE AVAILABLE AT THE TIME THIS MANUAL WAS PRINTED.

ITEM	USAGE	CAT. NO.
Leg Set	Mounting Miter Saw	9 22246
Blade (Master Combination)	Large Hard and Soft Wood	9 32495
Blade (Chisel-Tooth Combination)	All Purpose Hard and Soft Wood	9 32665
Blade (Crosscut Plywood)	Plywood, Fiberboard, Plastics	9 32449

WARNING: CARBIDE TIPPED BLADES ARE NOT RECOMMENDED FOR USE ON THIS SAW. THE USE OF ATTACHMENTS OR ACCESSORIES NOT LISTED ABOVE MIGHT BE HAZARDOUS.

HELPFUL HINTS

- Always clamp workpiece securely for cutting.
- A safe operator is one who thinks ahead.
- Always wear eye protection when sawing.
- Make set-up adjustments carefully. Then double check.
- Don't let familiarity make you careless.
- Study all safety rules and do the job safely.
- NEVER place your hands in jeopardy.
- Make certain clamps can't loosen while in use.
- Test difficult set-ups on scrap - Don't waste lumber.
- Plan each operation before you begin.
- Remember - Guards must always be used.
- **THINK SAFETY BY THINKING AHEAD.**

TROUBLE SHOOTING

PROBLEM	POSSIBLE CAUSE	WHAT TO DO
Saw will not run.	<ol style="list-style-type: none"> 1. Saw not plugged in to power supply. 2. Fuse blown or circuit breaker tripped. 3. Damaged cord. 4. Motor brushes worn. 5. Faulty switch. 	<ol style="list-style-type: none"> 1. Connect saw to power supply. 2. Replace fuse or reset circuit breaker. Check for circuit overload. 3. Replace cord. See Page 18 4. Replace brushes. See Page 18 5. Replace switch. See Page 18.
Mechanical brake not functioning.	<ol style="list-style-type: none"> 1. Faulty brake linkage. 2. Worn brake lining. 	Contact your nearest Sears Service Center or Sears Store.
Blade does not reach full speed.	<ol style="list-style-type: none"> 1. Extension cord too light or too long. 2. Low house voltage. 3. Sticking motor brush. 4. Blade improperly tightened. 	<ol style="list-style-type: none"> 1. Replace with proper size cord. See Page 6 2. Contact your power company. 3. Remove brush and check for uniform surfaces or binding. 4. See Blade Assembly, Page 6.
Saw vibrates excessively.	<ol style="list-style-type: none"> 1. Saw not mounted to bench or supporting surface securely. 2. Bench or support on uneven floor or surface. 3. Damaged saw blade. 	<ol style="list-style-type: none"> 1. Tighten all mounting screws. See Page 6. 2. Reposition on flat level surface. Fasten securely. 3. Replace blade. See Page 19.
Saw makes rough cuts.	<ol style="list-style-type: none"> 1. Dull blade. 2. Blade mounted backwards. 3. Gum or pitch on blade. 4. Incorrect blade for job. 5. Heel setting incorrect. 	<ol style="list-style-type: none"> 1. Replace blade, See Page 19 2. Turn blade around. 3. Remove and clean blade. 4. Change the blade. See Page 21. 5. Check heel adjustment. See Page 8.
Material pinches blade.	<ol style="list-style-type: none"> 1. Cutting bowed material in wrong position. 2. Fences not aligned. 3. Heel Setting Incorrect. 	<ol style="list-style-type: none"> 1. Position material as shown. See Page 14. 2. Check fence to fence alignment. See Page 9. 3. Check heel adjustment. See Page 8.
Saw does not make accurate cross cuts or miter cuts.	<ol style="list-style-type: none"> 1. Detent lever not adjusted correctly. 2. Blade is "heeling." 3. Misaligned fences. 4. Excessive looseness in turntable. 5. Excessive looseness in saw arm. 6. Excessive Looseness in Saw Head. 	<ol style="list-style-type: none"> 1. Readjust Detent Lever. See Page 9. 2. Check blade heel adjustment. See Page 8. 3. Check fence to blade and fence to fence adjustment. See Pages 8 and 9. 4. Check turntable adjustment. See Page 20. 5. Check blade centering adjustment. See Page 7. 6. Check Motor Play Adjustment. See Page 20.
Saw does not make accurate bevel cuts.	<ol style="list-style-type: none"> 1. Bevel setting incorrect 2. Heel setting incorrect. 3. Excessive looseness in saw arm. 	<ol style="list-style-type: none"> 1. Check bevel adjustment. See Page 1. 2. Check heel adjustment. See Page 8. 3. Check blade centering adjustment. See Page 7.
Miter arm difficult to rotate	<ol style="list-style-type: none"> 1. Sawdust or wood chips binding turntable. 	<ol style="list-style-type: none"> 1. Clean out turntable. See Page 20.

CRAFTSMAN RADIAL ARM MITER SAW — MODEL NUMBER 315.23743

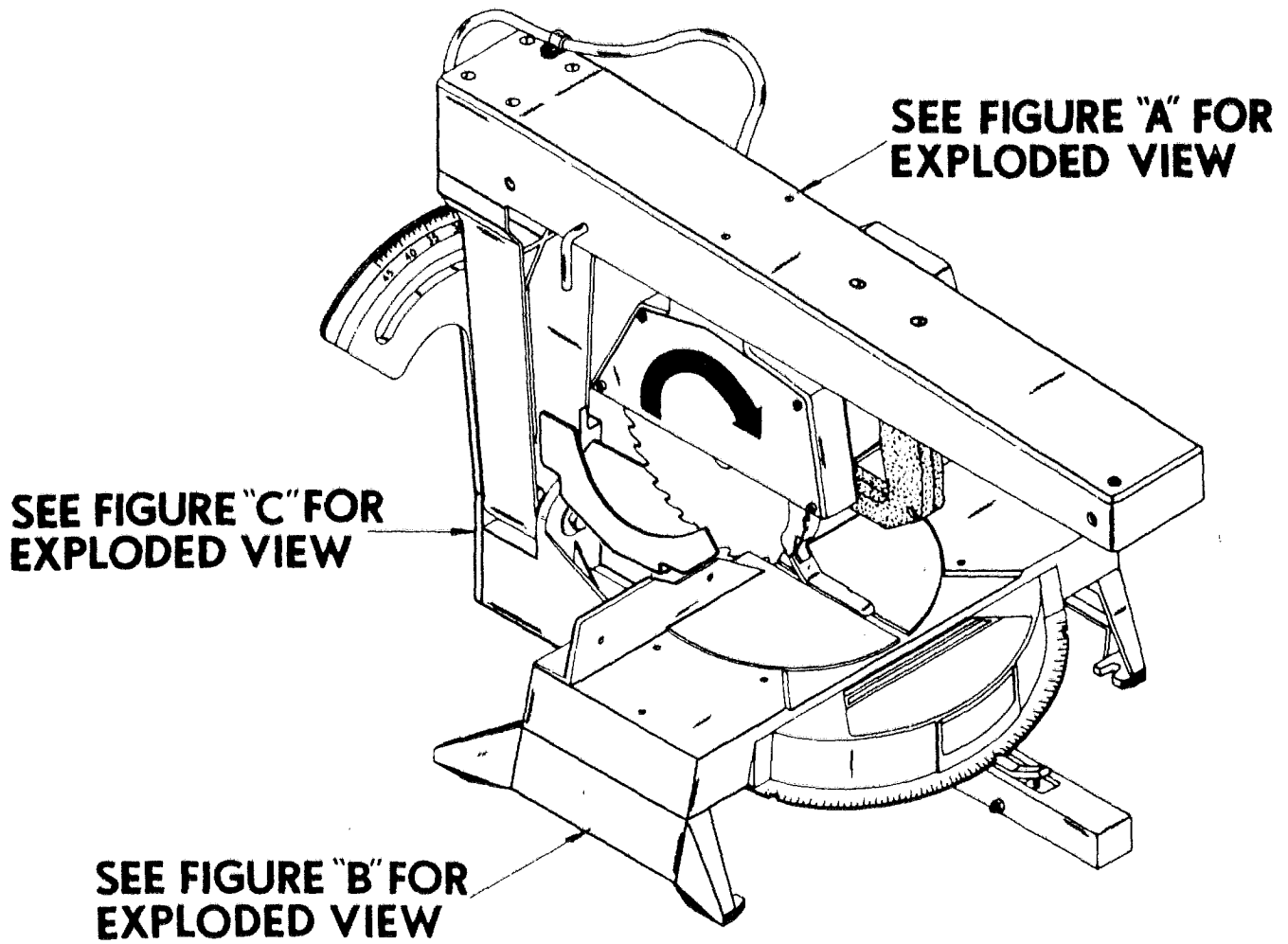

CRAFTSMAN RADIAL ARM MITER SAW — MODEL NUMBER 315.23743

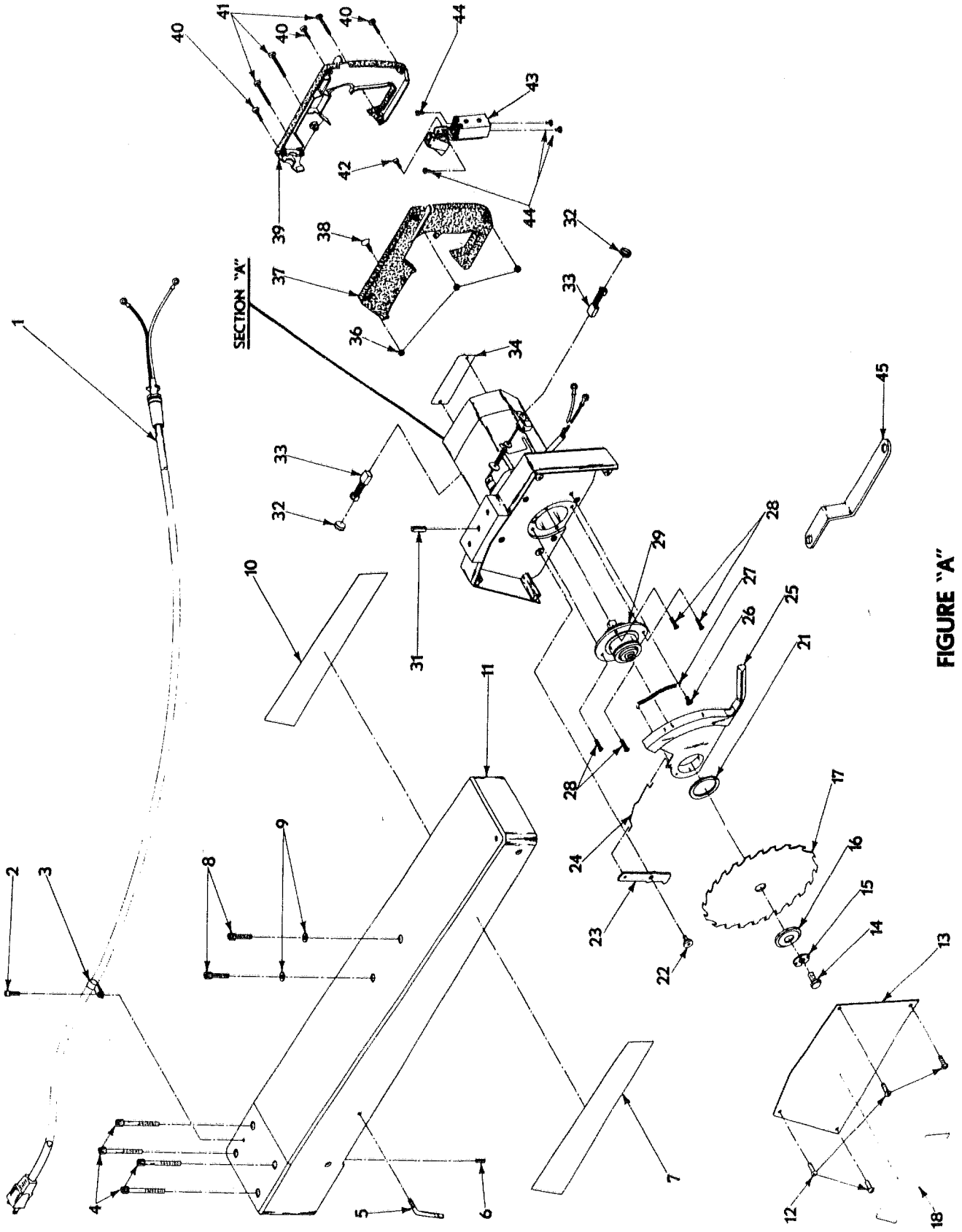

FIGURE "A"

CRAFTSMAN RADIAL ARM MITER SAW — MODEL NUMBER 315.23743

The Model Number will be found on a plate attached to the Motor End Cap.
Always mention the Model Number in all correspondence regarding your
RADIAL ARM MITER SAW or when ordering repair parts.

SEE BACK PAGE FOR PARTS ORDERING INSTRUCTIONS

FIGURE A PARTS LIST

Key No.	Part Number	Description	Quantity	Key No.	Part Number	Description	Quantity
1	611638-004	Cord Assembly.....	1	23	611807-002	Lever.....	1
2	622180-001	*Screw (#8-32 x 1/2 Pan Hd.)	1	24	611806-002	Connector.....	1
3	989001-001	Clamp.....	1	25	611815-001	Lower Blade Guard.....	1
4	621644-006	*Socket Head Cap Screw (1/4-20 x 2).....	4	26	795247-037	Drive Screw.....	1
5	612465-002	Locking Lever.....	1	27	617550-001	Spring.....	1
6	941401-023	Roll Pin.....	1	28	611114-001	*Screw (8-32 x 1/2 Flat Hd.)..	4
7	989959-001	Saw Arm Logo (Left).....	1	29	989680-001	Blade Spindle Assembly...1	
8	621644-002	*Socket Head Cap Screw (1/4-20 x 1).....	2	31	941401-825	Roll Pin.....	1
9	931744-811	Washer.....	2	32	617020-001	Brush Cap.....	2
10	989960-001	Saw Arm Logo (Right).....	1	33	612219-001	Brush.....	2
11	989048-001	Saw Arm Assembly.....	1	34	990549-001	Data Plate.....	1
12	614658-010	*Screw (8-32 x 3/8 Pan Hd.) **STD510803.....	4	36	706404-007	*Hex Nut (#8-32) **STD541008.....	3
13	989165-004	Blade Cover.....	1	37	989116-000	Handle (Includes Key #39)..	1
14	989645-001	Blade Screw.....	1	38	703428-025	*Screw (#8-32 x 1/2 Flat Hd.)	1
15	623547-002	Spring Washer.....	1	39	989116-000	Handle Cover (Includes Key #37).....	1
16	989630-003	Outer Blade Washer.....	1	40	614658-005	*Screw (8-32 x 7/8 Pan Hd.)..	3
17	611897-001	***Saw Blade - 7-1/2 Inch For 5/8" Arbor.....	1	41	614658-024	*Screw (8-32 x 1-1/2 Pan Hd.)	3
18	989963-001	Warning Plate.....	1	42	617966-006	Screw.....	1
21	718602-805	Retaining Ring.....	1	43	989447-001	Switch (Includes Key #44)..	1
22	990454-001	*Screw.....	1	44	617103-001	*Screw (#6-32 x 3/16 Pan Hd.) **STD510602.....	4
				45	612458-002	Wrench.....	1

SECTION "A" — The assembly shown represents an important part of the Double Insulated System. To avoid the possibility of alteration or damage to the System, service should be performed by your nearest Sears Repair Center. Contact your nearest Catalog Order or Retail Store.

*Standard Hardware Item — May Be Purchased Locally
 **Available From Div. 98 — Source 980.00
 ***Refer to Page 21 of Owners Manual for Recommended Saw Blades

CRAFTSMAN RADIAL ARM MITER SAW — MODEL NUMBER 315.23743

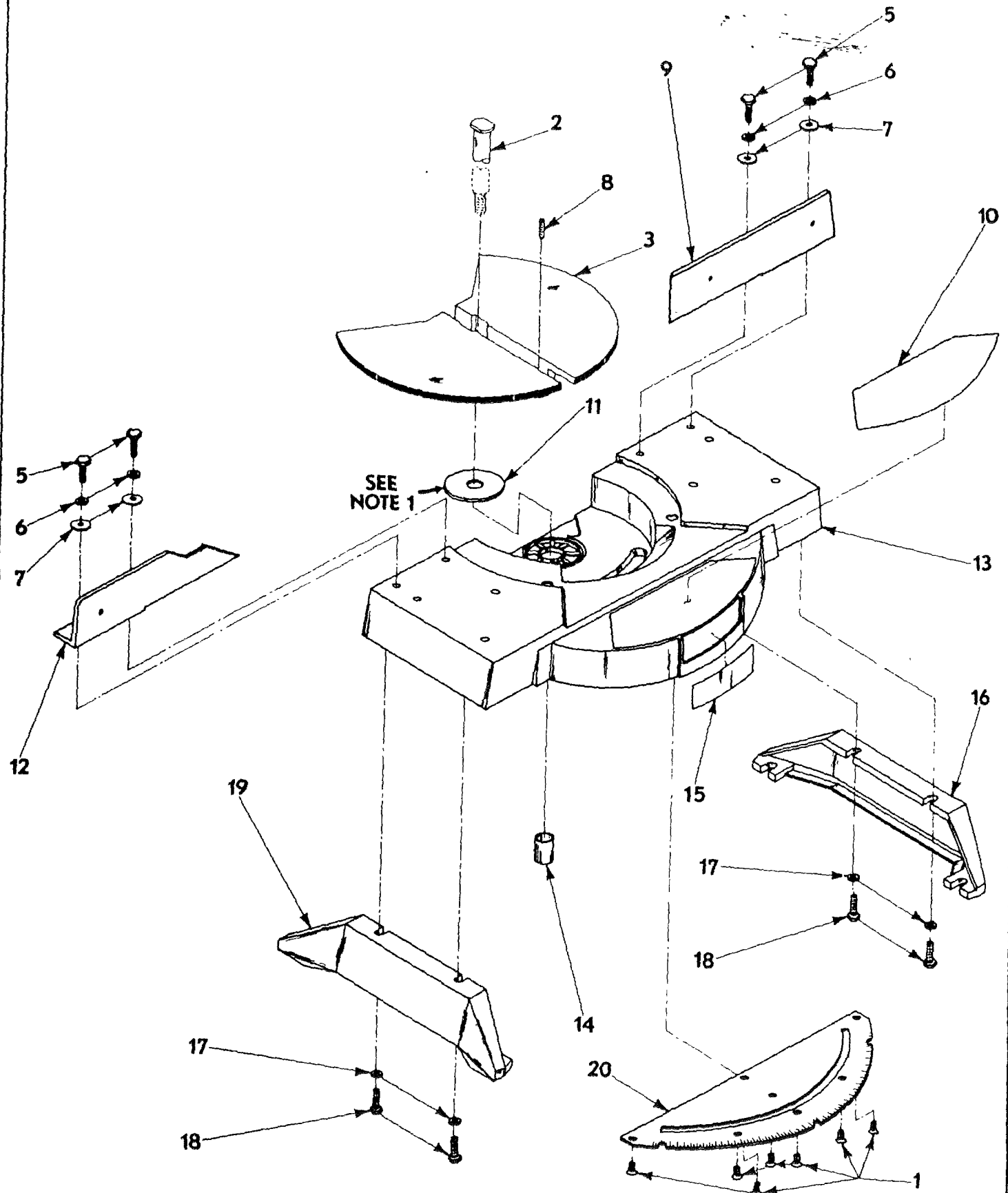

NOTE 1: COAT WITH LIGHT
FILM OF HIGH PRESSURE GREASE

FIGURE "B"

CRAFTSMAN RADIAL ARM MITER SAW — MODEL NUMBER 315.23743

The Model Number will be found on a plate attached to the Motor End Cap. Always mention the Model Number in all correspondence regarding your **RADIAL ARM MITER SAW** or when ordering repair parts.

SEE BACK PAGE FOR PARTS ORDERING INSTRUCTIONS

FIGURE B PARTS LIST

Key No.	Part Number	Description	Quantity
1	703428-010	*Screw (#8-32 x 3/8 Flat Head).....	7
2	989229-002	Pintle Bolt.....	1
3	989227-003	Turntable.....	1
5	703427-035	*Screw (1/4-20 x 1-1/4 Hex Head).....	4
6	703473-032	*Lockwasher (1/4) **STD551125.....	4
7	931744-006	Washer **STD551225.....	4
8	930687-008	*Set Screw.....	1
9	610490-003	Fence — Right.....	1
10	989961-001	Logo Plate.....	1
11	612875-003	Washer.....	1
12	611783-003	Fence — Left.....	1
13	610393-009	Table (Includes Key No. 14).....	1
14	610510-002	Sleeve Bearing.....	1
15	989956-001	Logo Plate.....	1
16	610494-003	Foot — Right.....	1
17	703473-042	*Lockwasher (5/16) **STD551131.....	4
18	622439-005	*Screw (5/16-18 x 3/4 Hex Head).....	4
19	610493-003	Foot — Left.....	1
20	610489-003	Quadrant.....	1

*Standard Hardware Item — May Be Purchased Locally
 **Available From Div. 98 — Source 980.00

CRAFTSMAN RADIAL ARM MITER SAW — MODEL NUMBER 315.23743

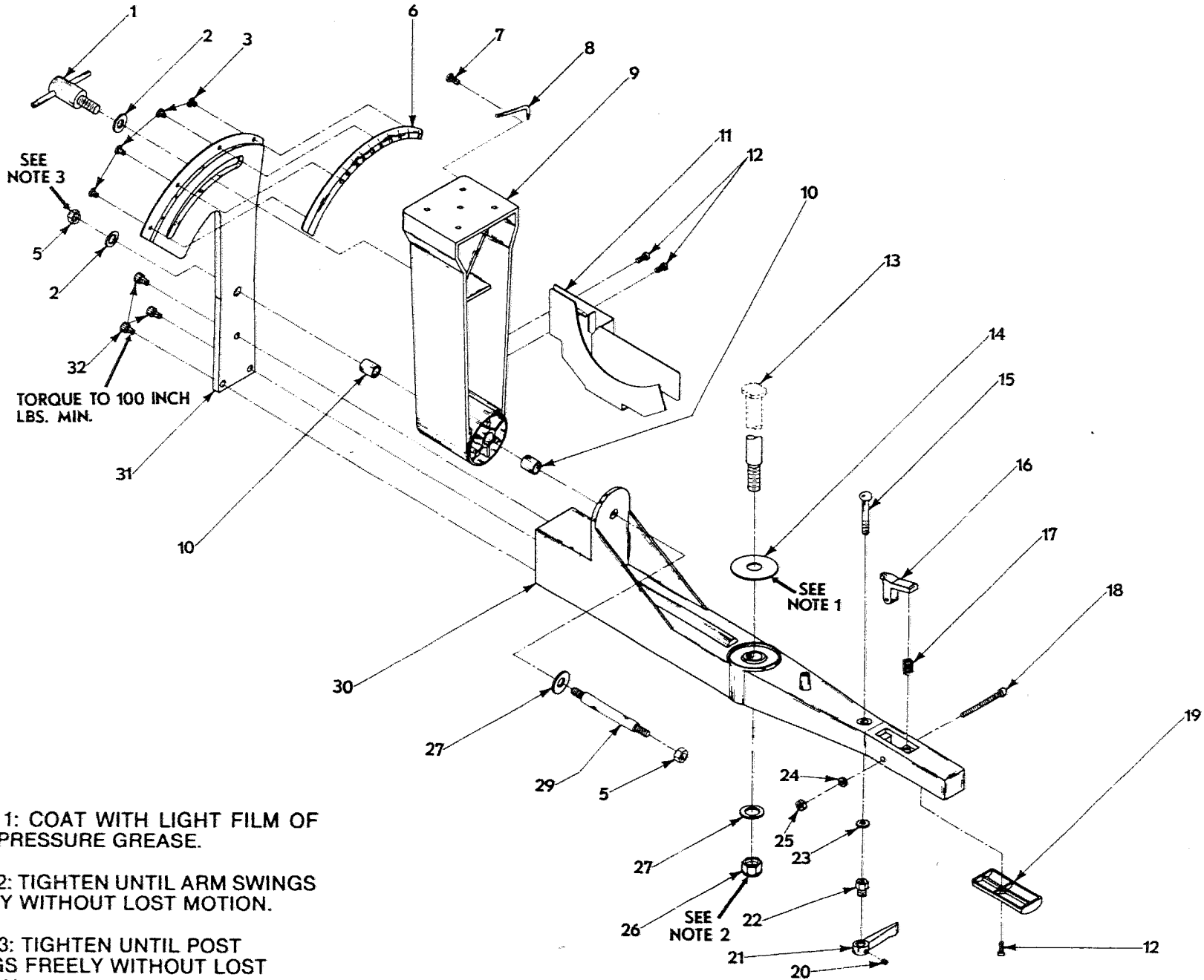

FIGURE "C"

CRAFTSMAN RADIAL ARM MITER SAW — MODEL NUMBER 315.23743

The Model Number will be found on a plate attached to the Motor End Cap.
Always mention the Model Number in all correspondence regarding your
RADIAL ARM MITER SAW or when ordering repair parts.

SEE BACK PAGE FOR PARTS ORDERING INSTRUCTIONS

FIGURE C PARTS LIST

Key No.	Part Number	Description	Quantity	Key No.	Part Number	Description	Quantity
1	989006-002	Lock Screw Assembly.....	1	19	612271-001	Handle Cover.....	1
2	703776-098	Washer (3/8").....	2	20	930687-002	*Set Screw (#8-32 x 3/16)	
3	617966-003	Screw.....	4		**STD500802.....	1	
5	621377-004	*Nut (3/8-16).....	2	21	617483-004	Locking Lever.....	1
6	612681-001	Quadrant Insert.....	1	22	611642-003	Locking Nut.....	1
7	614658-010	*Screw (#8-32 x 3/8 Pan Hd.)		23	931744-006	Washer (1/4") **STD551225..	1
		**STD510803.....	1	24	703473-032	*Lockwasher (1/4")	
8	611767-002	Pointer.....	1		**STD551125.....	1	
9	611800-004	Post (Includes Key #10).....	1	25	621377-003	*Hex Nut (1/4-28)	
10	621359-000	Sleeve Bearing.....	2		**STD541125.....	1	
11	990542-002	Striker Guard.....	1	26	703477-047	*Hex Lock Nut (1/2-13)	
12	622180-001	*Screw (#8-32 x 1/2 Pan Hd.)...3			**STD541450.....	1	
13	989229-002	Pintle Bolt.....	1	27	610019-003	Disk Spring.....	2
14	612875-002	Washer.....	1	29	611772-003	Trunnion Shaft.....	1
15	621433-009	Carriage Bolt.....	1	30	611825-003	Miter Arm.....	1
16	610541-005	Locking Lever.....	1	31	611790-003	Quadrant.....	1
17	617802-001	Spring.....	1	32	621644-004	*Hex Socket Cap Screw	
18	612361-001	*Screw (1/4-28 x 1-7/8 Fil. Hd.)..1			(1/4-20 x 3/4").....	3	
					612547-228	Owners Manual	

*Standard Hardware Item — May Be Purchased Locally
**Available From Div. 98 — Source 980.00

SEARS

OWNERS
MANUAL

SERVICE

MODEL NO.
315.23743

HOW TO ORDER
REPAIR PARTS

CRAFTSMAN®

7½ INCH RADIAL ARM MITER SAW

DOUBLE INSULATED WITH MECHANICAL BRAKE

Now that you have purchased your Radial Arm Miter Saw, should a need ever exist for repair parts or service, simply contact any Sears Service Center and most Sears, Roebuck and Co. stores. Be sure to provide all pertinent facts when you call or visit.

The model number of your Radial Arm Miter Saw will be found on the plate attached to the motor end cap.

WHEN ORDERING REPAIR PARTS, ALWAYS GIVE THE FOLLOWING INFORMATION:

- | | |
|-----------------------------|--|
| ● PART NUMBER | ● PART DESCRIPTION |
| ● MODEL NUMBER
315.23743 | ● NAME OF ITEM
7-1/2 INCH RADIAL
ARM MITER SAW |

All parts listed may be ordered from any Sears Service Center and most Sears stores.

If the parts you need are not stocked locally, your order will be electronically transmitted to a Sears Repair Parts Distribution Center for handling.

Free Manuals Download Website

<http://myh66.com>

<http://usermanuals.us>

<http://www.somanuals.com>

<http://www.4manuals.cc>

<http://www.manual-lib.com>

<http://www.404manual.com>

<http://www.luxmanual.com>

<http://aubethermostatmanual.com>

Golf course search by state

<http://golfingnear.com>

Email search by domain

<http://emailbydomain.com>

Auto manuals search

<http://auto.somanuals.com>

TV manuals search

<http://tv.somanuals.com>