

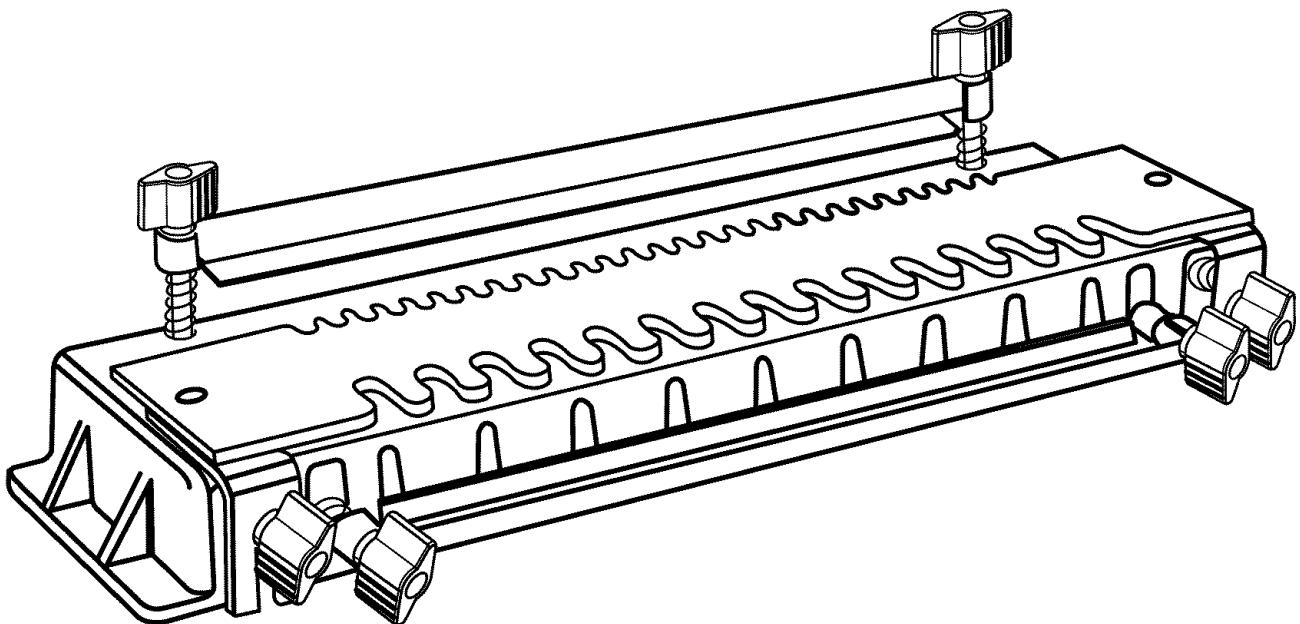
OPERATOR'S MANUAL



ROUTER DOVETAIL JOINT TEMPLATE KIT

**MODEL NO.
315.25791**

**FOR USE WITH ROUTERS WITH
3-HOLE TEMPLATE GUIDE MOUNT.**



⚠ WARNING: To reduce the risk of injury, the user must read and understand the operator's manual before using this product.

Customer Help Line: 1-800-932-3188

Sears, Roebuck and Co., 3333 Beverly Rd., Hoffman Estates, IL 60179 USA
Visit the Craftsman web page: www.sears.com/craftsman


TABLE OF CONTENTS

■ Introduction	2
■ General Safety Rules	3
■ Symbols.....	4
■ Assembly	5
■ Operation.....	6-18
■ Troubleshooting	18
■ Exploded View and Parts List.....	19-20
■ Parts Ordering/Service	Back Page

INTRODUCTION


This accessory has many features for making its use more pleasant and enjoyable. Safety, performance, and dependability have been given top priority in the design of this product making it easy to maintain and operate.

GENERAL SAFETY RULES

 **WARNING: read and understand all instructions.** Failure to follow all instructions listed below, may result in electric shock, fire and/or serious personal injury.

SAVE THESE INSTRUCTIONS

- **Read these instructions and the instructions for your router thoroughly** before using accessory.
- **Know your power tool.** Read the operator's manual for your router carefully. Learn the router's applications and limitations as well as the specific potential hazards related to this tool.
- **Always wear safety glasses. Everyday eyeglasses have only impact-resistant lenses; they are not safety glasses.** Following this rule will reduce the risk of serious personal injury.
- **Always disconnect router from power supply before making adjustments or adding accessories.** Make sure the switch is off when reconnecting to power supply.
- **Keep your work area clean and well lit.** Cluttered benches and dark areas invite accidents.
- **Do not operate power tools in explosive atmospheres, such as in the presence of flammable liquids, gases, or dust.** Power tools create sparks which may ignite the dust or fumes.
- **Keep bystanders, children, and visitors away while operating a power tool.** Distractions can cause you to lose control.
- **Stay alert, watch what you are doing and use common sense when operating a power tool. Do not use tool while tired or under the influence of drugs, alcohol, or medication.** A moment of inattention while operating power tools may result in serious personal injury.
- **Avoid accidental starting. Be sure switch is off before plugging in.** Carrying tools with your finger on the switch or plugging in tools that have the switch on invites accidents.
- **Do not overreach. Keep proper footing and balance at all times.** Proper footing and balance enables better control of the tool in unexpected situations.
- **Use clamps or other practical way to secure and support the workpiece to a stable platform.** Holding the work by hand or against your body is unstable and may lead to loss of control.
- **Disconnect the plug from power source before making any adjustments, changing accessories, or storing the tool.** Such preventive safety measures reduce the risk of starting the tool accidentally.
- **Keep the tool and its handle dry, clean and free from oil and grease.** Always use a clean cloth when cleaning. Never use brake fluids, gasoline, petroleum-based products, or any strong solvents to clean your tool. Following this rule will reduce the risk of loss of control and deterioration of the enclosure plastic.
- **Protect your lungs. Wear a face or dust mask if the operation is dusty.** Following this rule will reduce the risk of serious personal injury.
- **Protect your hearing. Wear hearing protection during extended periods of operation.** Following this rule will reduce the risk of serious personal injury.
- **Inspect tool cords periodically and, if damaged, have repaired at your nearest authorized service center. Constantly stay aware of cord location.** Following this rule will reduce the risk of electric shock or fire.
- **Check damaged parts. Before further use of the tool, a guard or other part that is damaged should be carefully checked to determine that it will operate properly and perform its intended function. Check for alignment of moving parts, binding of moving parts, breakage of parts, mounting, and any other conditions that may affect its operation. A guard or other part that is damaged should be properly repaired or replaced by an authorized service center.** Following this rule will reduce the risk of shock, fire, or serious injury.
- **Inspect for and remove all nails from lumber before using this tool.** Following this rule will reduce the risk of serious personal injury.
- **Save these instructions.** Refer to them frequently and use them to instruct others who may use this tool. If you loan someone this tool, loan them these instructions also.




 **WARNING:** Some dust created by power sanding, sawing, grinding, drilling, and other construction activities contains chemicals known to cause cancer, birth defects or other reproductive harm. Some examples of these chemicals are:

- lead from lead-based paints,
- crystalline silica from bricks and cement and other masonry products, and
- arsenic and chromium from chemically-treated lumber.

Your risk from these exposures varies, depending on how often you do this type of work. To reduce your exposure to these chemicals: work in a well ventilated area, and work with approved safety equipment, such as those dust masks that are specially designed to filter out microscopic particles.


SYMBOLS

The following signal words and meanings are intended to explain the levels of risk associated with this product.

SYMBOL	SIGNAL	MEANING
	DANGER:	Indicates an imminently hazardous situation, which, if not avoided, will result in death or serious injury.
	WARNING:	Indicates a potentially hazardous situation, which, if not avoided, could result in death or serious injury.
	CAUTION:	Indicates a potentially hazardous situation, which, if not avoided, may result in minor or moderate injury.
	CAUTION:	(Without Safety Alert Symbol) Indicates a situation that may result in property damage.

SERVICE

Servicing requires extreme care and knowledge and should be performed only by a qualified service technician. For service we suggest you return the product to your nearest **AUTHORIZED SERVICE CENTER** for repair. When servicing, use only identical replacement parts.

 **WARNING:** To avoid serious personal injury, do not attempt to use this product until you read thoroughly and understand completely the operator's manual. Save this operator's manual and review frequently for continuing safe operation and instructing others who may use this product.

WARNING:



The operation of any power tool can result in foreign objects being thrown into your eyes, which can result in severe eye damage. Before beginning power tool operation, always wear safety goggles or safety glasses with side shields and a full face shield when needed. We recommend Wide Vision Safety Mask for use over eyeglasses or standard safety glasses with side shields. Always use eye protection which is marked to comply with ANSI Z87.1.

SAVE THESE INSTRUCTIONS

ASSEMBLY

UNPACKING

This product requires assembly.

- Carefully remove all parts from the box. Make sure that all items listed in the packing list are included.
- Inspect the parts carefully to make sure no breakage or damage occurred during shipping.
- Do not discard the packing material until you have carefully inspected and satisfactorily operated the accessory.
- If any parts are damaged or missing, please call 1-800-932-3188 for assistance.

PACKING LIST

Item No.	Description	Qty.
1	Dovetail Template and Base	1
2	Hex Bolt (1/4-20 x 3 in.)	4
3	Nut (1/4-20)	4
4	Spring	4
5	Washer	8
6	Clamp Bar	2
7	Clamping Knob	4
8	5/16 in. Guide Bushing	1
9	7/16 in. Guide Bushing	1
10	Screw (10-32 x 7/8 in. Flat Head)	3
11	Operator's Manual	

WARNING: If any parts are missing do not operate this accessory until the missing parts are replaced. Failure to do so could result in possible serious personal injury.

WARNING: Do not attempt to modify this accessory. Any such alteration or modification is misuse and could result in a hazardous condition leading to possible serious personal injury.

WARNING: Do not connect router to power supply until assembly is complete. Failure to comply could result in accidental starting and possible serious injury.

TOOLS NEEDED

In addition to the dovetail template and guide bushing, you will also need a Craftsman Router and a dovetail cutter. Use dovetail cutter Catalog Number 26319 for making 1/4 in. dovetail joints and Catalog Number 26318, 25505 for making 1/2 in. joints.

ASSEMBLING YOUR DOVETAIL TEMPLATE

See Figure 1.

- Insert hex bolts through holes located at top and front of dovetail base as shown in figure 1.
- Make sure the bolt head flats are lined up with slots inside the dovetail base.
- Secure hex bolt with hex nuts supplied.
- Place one spring over each hex bolt.
- Place a washer on top of each spring, then install clamp bar on top of washer.
- **NOTE:** For proper assembly, be sure to turn each clamp bar as shown in Figure 1.
- Place a second washer on top and/or end of each clamp bar.
- Thread a clamping knob onto each hex bolt to secure washers, clamp bars, and springs.

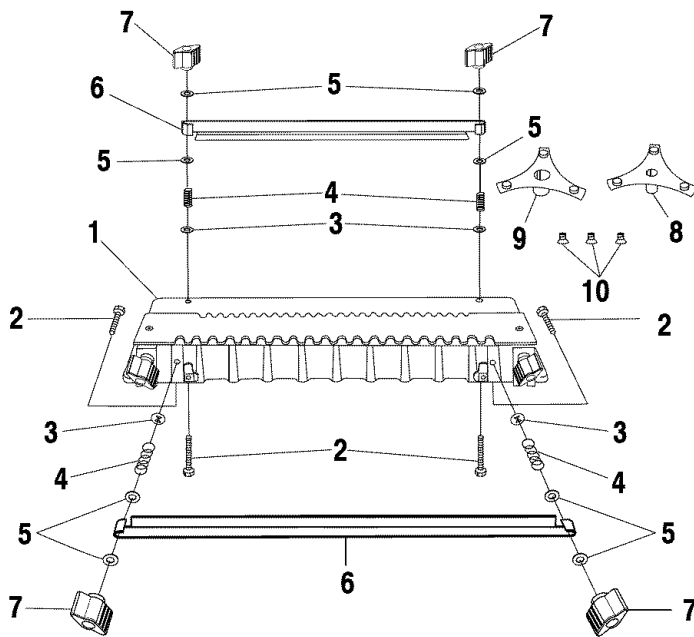


Fig. 1

OPERATION

- WARNING:** Do not allow familiarity with tools to make you careless. Remember that a careless fraction of a second is sufficient to inflict serious injury.
- WARNING:** Always wear safety goggles or safety glasses with side shields when operating power tools. Failure to do so could result in objects being thrown into your eyes resulting in possible serious injury.
- WARNING:** Do not use any attachments or accessories not recommended by the manufacturer of this tool. The use of attachments or accessories not recommended can result in serious personal injury.

APPLICATIONS

You may use this tool for the purposes listed below:
See Figure 2.

- Cutting Flush Joints
- Cutting Offset Joints
- Cutting Rabbeted Joints

Your router dovetail template kit has been designed for cutting flush, offset, or rabbeted joints with speed and accuracy. Since these joints are both strong and neat, they are commonly used when making drawers and boxes.

Read all instructions carefully, and follow closely while making set ups and adjustments.

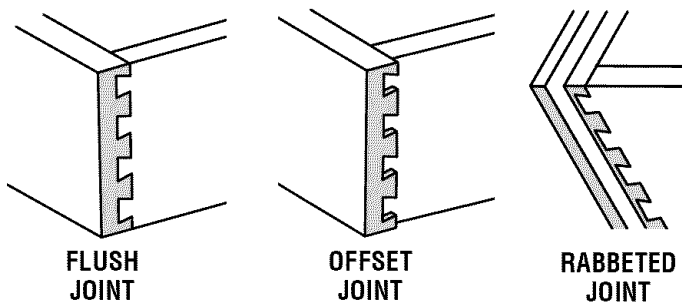


Fig. 2

NOTE: Once all adjustments have been properly made, make a trial cut with scrap pieces of the same wood used for the finished work.

This step allows you to check your adjustments. It also makes you aware of the characteristics of the particular wood being used.

MOUNTING DOVETAIL BASE

See Figures 3 - 4.

- WARNING:** For safe operation and proper control, your router dovetail template kit must be mounted to a workbench or table.

If desired, it can be clamped to a workbench with "C" clamps, or it can be mounted onto a 3/4 in. piece of plywood for mobility.

- Clamp the dovetail base to a workbench or table with "C" clamps. It can then be easily removed upon completion for easy storage or changing job sites.

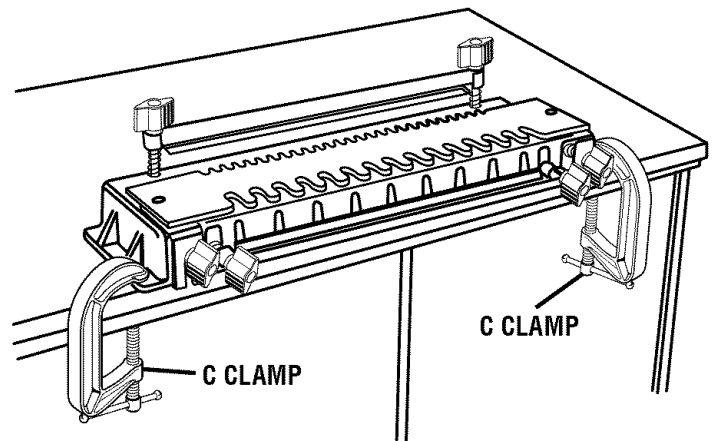


Fig. 3

- A second, more preferred, method would be to mount your dovetail base onto a piece of 3/4 in. plywood approximately six inches wide and twenty-four inches long. Position front of base flush with the front and centered with the ends of the board, then insert four flat head wood screws through holes in the base and secure firmly into plywood. The dovetail base (with wooden base) may then be clamped securely to workbench or table with "C" clamps or other holding apparatus. Here again, it can be easily removed upon completion for easy storage or changing job sites.

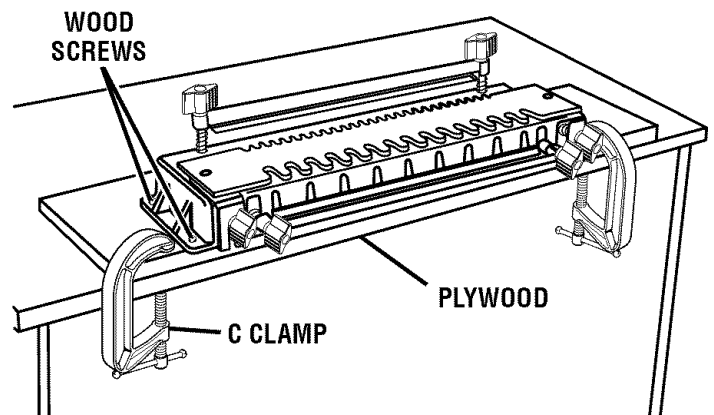


Fig. 4

OPERATION

INSTALLING TEMPLATE GUIDE BUSHING AND CUTTER

See Figure 5.

Two template guide bushings are supplied with the router dovetail template kit. They are used to guide the router in and out of the fingers of the comb-shaped template. The 5/16 in. bushing is used when making 1/4 in. dovetails, while the 7/16 in. bushing is used when making 1/2 in. dovetails.

⚠ WARNING: To avoid possible serious personal injury, unplug the router while assembling parts or making adjustments.

- Attach guide bushing directly to the inside of the router subbase.

NOTE: It is not necessary to remove subbase while attaching guide bushing, but be sure collar section is turned facing away from the router motor.

- Secure bushing to the router subbase with the 3 screws supplied.
- Insert dovetail cutter through guide bushing and into collet at least 3/4 in. If 3/4 in. engagement does not exist, lower the router motor in the router base until collet nut is approximately 1/8 in. clear of guide bushing.
- Tighten securely before attempting to center cutter inside guide bushing. If clamp is not tight, the router motor will be loose and wobble inside router base while adjustments are being made.
- Visually center the cutter with the inside diameter of the guide bushing, then tighten the collet nut securely.

NOTE: When centering cutter in guide bushing, adjustments can be made by loosening the screws holding the subbase to the router and/or loosening the screws holding the guide bushing to the router.

- Tighten all screws securely.

BEGIN YOUR SET-UP

See Figure 6.

To begin your set-up, you will need to determine what the final dimensions for your drawer or box will be, then cut your boards to size. If you plan in advance, try to size the drawer opening so that a half-pin will be on both the top and bottom edge of the drawer front. See helpful hints, page 18. See the chart on page 8 for computing proper sizes and recommended material thicknesses.

Next, decide whether you are going to make 1/4 in. or 1/2 in. joints. The dovetail template is packaged with the angle brackets set for making 1/2 in. joints. If 1/4 in. joints are desired, loosen the two screws holding the angle brackets, and reverse them 180°. Re-tighten angle bracket screws. Reverse the procedure when changing your template from 1/4 in. joints to 1/2 in. joints.

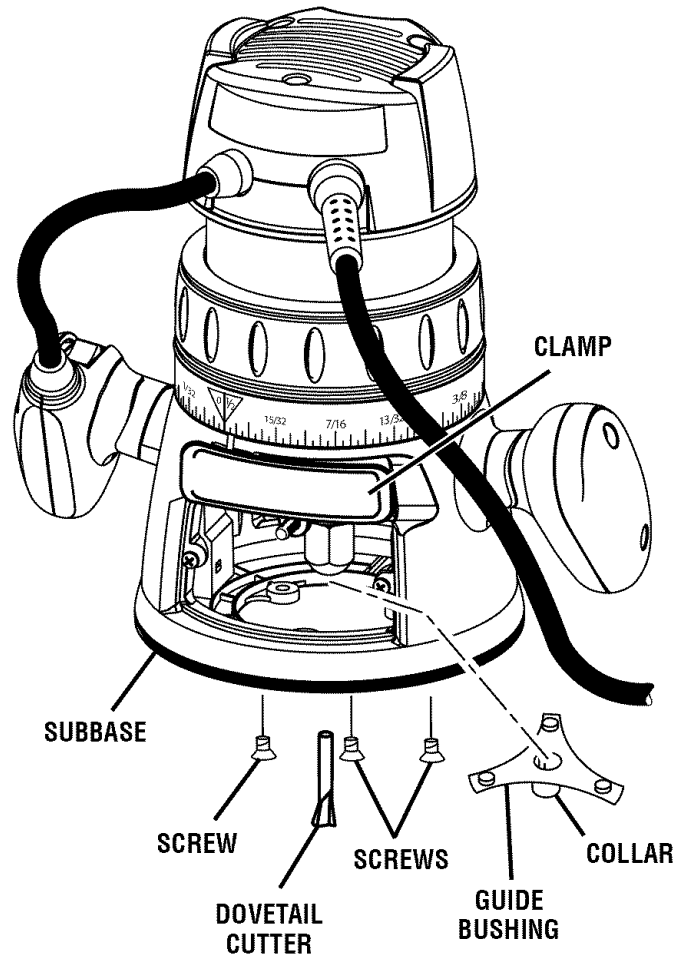


Fig. 5

NOTE: Plan your drawer height opening so that the boards will be in increments of 7/8 in. for 1/2 in. joints, or 29/64 in. increments for 1/4 in. joints. This will allow a half-pin to be on both the top and bottom edge of the drawer front. Don't forget to allow for clearances.

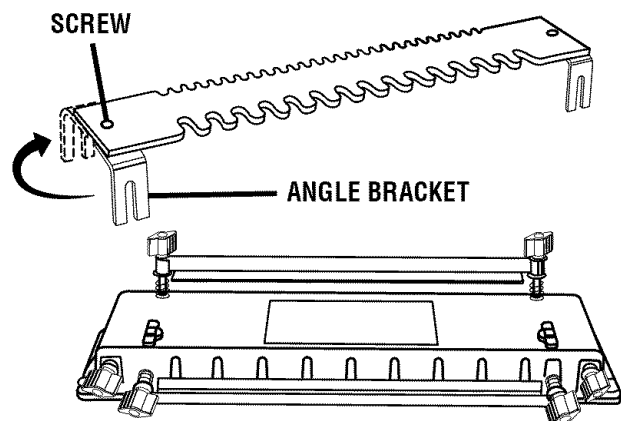


Fig. 6

OPERATION

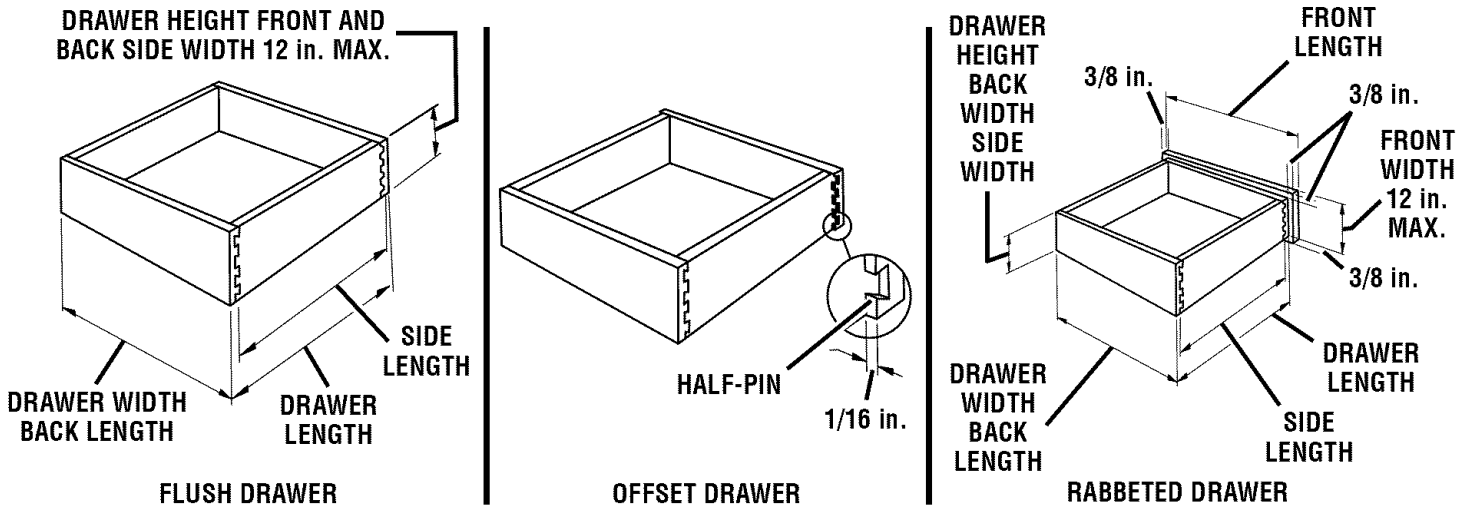


Fig. 7

1/2 in. DOVETAIL JOINTS			
Section	Recommended Thickness	Length	Width
Back - Flush/Rabbeted	1/2 in. to 3/4 in.	Width of opening less clearance	Height of opening less clearance
Back - Offset	1/2 in. to 3/4 in.	Front length minus 1/8 in.	Height of opening less clearance
Sides	1/2 in. to 3/4 in.	Must be determined for each job depending on depth of opening, clearance, and thickness of front and back	Same as back
Bottom	1/4 in. to 3/8 in.	Length of side less 1/4 in.	Length of back, plus 1/2 in. less 2 times side thickness
Flush Front	1/2 in. to 3/4 in.	Width of opening less clearance	Same as Back
Offset-Front	1/2 in. to 3/4 in.	Width of opening less clearance	Same as Back
3/8 in. Rabbeted Front	3/4 in.	Back Length plus 3/4 in.	Back width plus 3/4 in.

NOTE: Front, back and sides should be grooved 1/4 in. deep to receive bottom piece and may be done before or after dovetailing. If groove depth is more or less than 1/4 in., bottom dimensions must be altered to compensate.

1/4 in. DOVETAIL JOINTS			
Section	Recommended Thickness	Length	Width
Back - Flush/Rabbeted	5/16 in. to 3/4 in.	Width of opening less clearance	Height of opening less clearance
Back - Offset	5/16 in. to 3/4 in.	Front length minus 1/8 in.	Height of opening less clearance
Sides	1/4 in. to 1/2 in.	Must be determined for each job depending on depth of opening, clearance, and thickness of front and back	Same as back
Bottom	1/4 in.	Length of side less 1/4 in.	Length of back, plus 1/2 in. less 2 times side thickness
Flush Front	5/16 in. to 3/4 in.	Width of opening less clearance	Same as Back
Offset-Front	5/16 in. to 3/4 in.	Width of opening less clearance	Same as Back
3/8 in. Rabbeted Front	1/2 in. to 3/4 in.	Back Length plus 3/4 in.	Back width plus 3/4 in.

NOTE: Front, back and sides should be grooved 3/16 in. deep to receive bottom piece and may be done before or after dovetailing. If groove depth is more or less than 3/16 in., bottom dimensions must be altered to compensate.

OPERATION

REFERENCE GUIDE

See Figure 8.

The base of the router dovetail template kit has a label to serve as a guide for you to follow when making set-ups for different types of joinery. Familiarize yourself with this label and refer to it as often as necessary.

DOVETAIL TEMPLATE									
1/2 in. Tails				MODEL 315.25791	1/4 in. Tails				
JOINT	STOP		BRACKET LOCATION	BIT DEPTH	JOINT	STOP		BRACKET LOCATION	BIT DEPTH
	TOP	SIDE				TOP	SIDE		
FLUSH	A	A	1	17/32 in.	FLUSH	C	C	1	7/16 in.
OFFSET	A	A	2	17/32 in.	OFFSET	C	C	2	7/16 in.
RABBETED	B	A	3	17/32 in.	RABBETED	B	C	3	7/16 in.

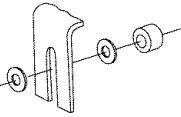
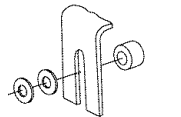
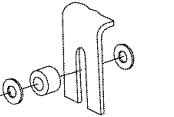
1	2	3
		

Fig. 8

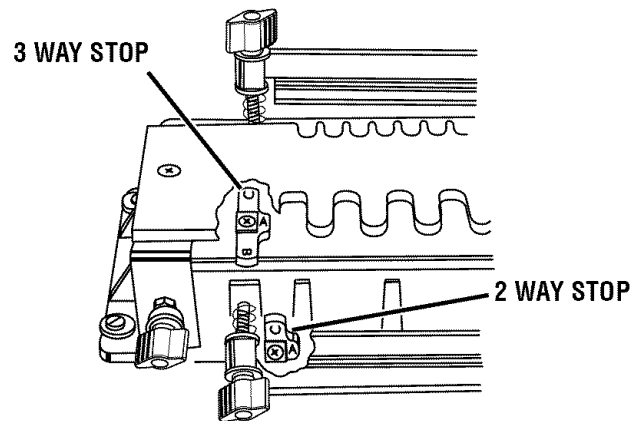


Fig. 10

FLUSH FRONT DRAWER OR BOX

WARNING: Unplug router from power supply while assembling parts or making adjustments. Failure to do so could result in accidental starting of the router causing damage to the work surface or possible serious personal injury.

Set Up

- Attach guide bushing with 7/16 in. pilot diameter to router base (5/16 in. pilot diameter for 1/4 in. joints). Insert the dovetail cutter bit through the guide bushing and into chuck collet at least 3/4 in., then tighten securely. See "Installing template guide bushing and cutter", Page 7.
- Adjust the base on the router until the cutter extends 17/32 in. beyond the router subbase for 1/2 in. joints. Adjust 7/16 in. beyond the router subbase for 1/4 in. joints. See Figure 9.

17/32 in. FOR
1/2 in. JOINTS

7/16 in. FOR
1/4 in. JOINTS

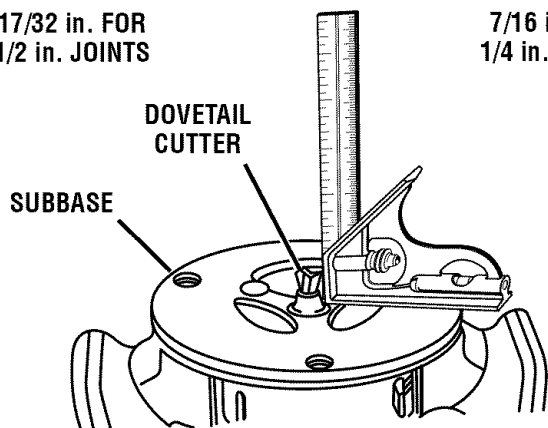


Fig. 9

- Loosen the stop screws and place the 3 way stop on top of the dovetail base and the 2 way stop on the side of the dovetail base in their proper position. See Figures 8 and 10. Retighten stop screws securely.
 - Mark the boards for the drawer or box on the inside with identifying letters near the bottom edge. See Figure 11.
- NOTE:** The reverse side of the board will be the outside of the finished drawer or box. The outside of the boards are always clamped towards the dovetail base and all pieces are routed in an "inside-out" position. The boards are then reversed to assemble.
- NOTE:** The material for front (B) and back (D) should be the same size and should be cut to fit the opening neatly. The side pieces (A and C) should also be the same size. See the chart on page 8 for computing proper sizes and recommended material thicknesses.

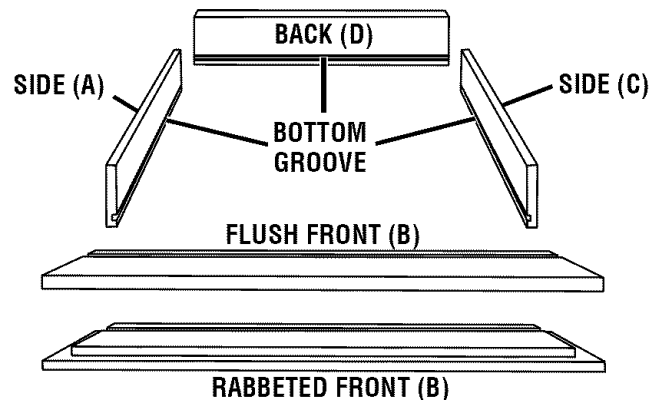


Fig. 11

OPERATION

- Insert board (A) between front clamping bar and front surface of dovetail base with bottom edge toward the left 2-way stop. Temporarily clamp board (A) “inside-out” to the left front of the fixture so that it extends above the base. See Figure 12. This is done to assist in the proper positioning of board (B).
- Insert board (B) between top clamping bar and top surface of dovetail base, with bottom edge against left 3-way stop, and flush with extended portion of board (A). See Figure 12.

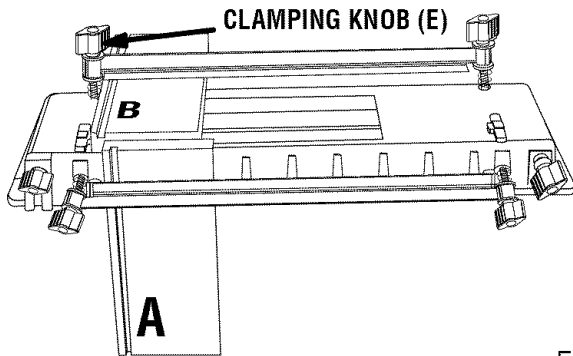


Fig. 12

- Tighten clamping knobs (E) on top clamping bar to hold board (B) securely.
- Relocate board (A) so that it is flush with the top of board (B) and against 2-way stop on left front of dovetail base. See Figure 13.
- Tighten front clamping knobs (E) to hold board (A) securely.

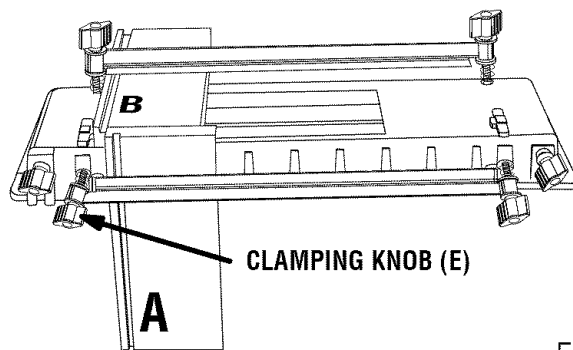


Fig. 13

- Attach comb-shaped template (F) to the dovetail base with washers (G) and spacers (H) in their desired location. See Figure 14.
- Hold the dovetail template flat on the boards with one hand, and tighten template clamping knobs (E) securely.

NOTE: Be sure dovetail template finger ends are parallel to edge of board (B) to assure even fitting after cutting.

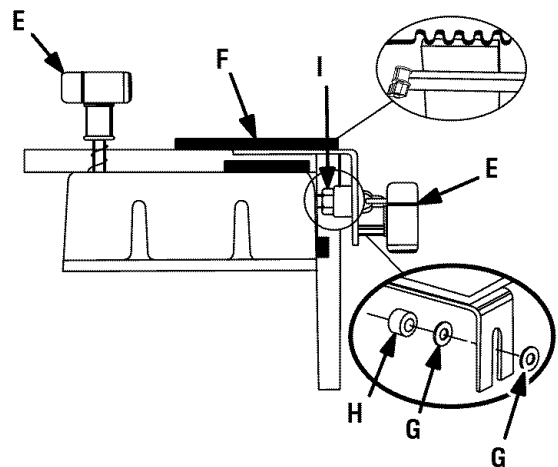


Fig. 14

Routing Your Flush Dovetail Joints

You are now ready to route your first flush dovetail joint. As mentioned earlier, you should make a trial cut with scrap pieces of the same wood used for the finished work. Using scrap pieces allows for adjustments to be made in the following steps.

- Place the router so that the subbase is resting flat on the dovetail template. Make sure the cutter is not making contact with the edge of board (A), then turn your router on and let the motor build to its full speed.
- Make a straight cut from **RIGHT TO LEFT** across board (A). See Figure 15. This shallow V-groove cut is made to prevent chipping of the wood when the router is moved in and out of the fingers of your dovetail template.

NOTE: When making 1/4 in. dovetails, one or two extra passes may be necessary to cut away excess stock projecting beyond the fingers of the dovetail template.

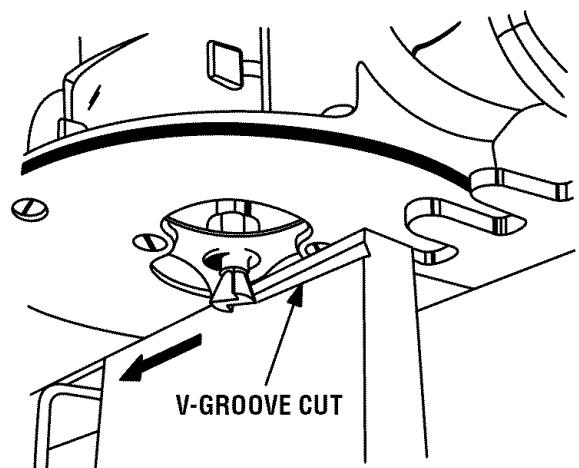


Fig. 15

OPERATION

WARNING: Use caution when operating router at either extreme end of dovetail template. The dovetail cutter will make contact with angle bracket if moved too far outside first or final cut.

- Cut the dovetail joint. Feed the router in and out each finger, moving from left to right.
- Recut the dovetail moving the router from right to left. This will clean off any spots or imperfections that might have been missed.
- To prevent possible serious injury or damage to the dovetail template, wait until the cutter has completely stopped before removing the router. When removing the router it should not be lifted but should be moved toward the operator until clear.
- Check to make sure you have routed each dovetail evenly.

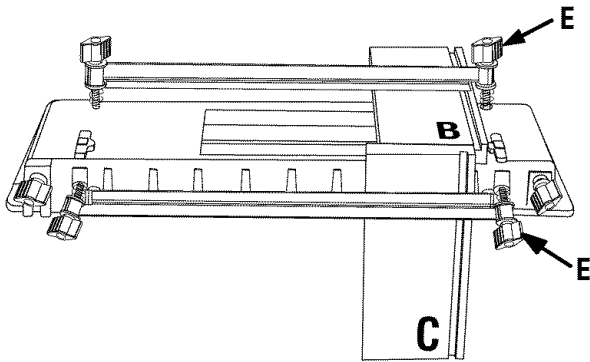


Fig. 16

- Once everything looks okay — remove the two pieces and tap them together. If properly set up, they will fit together. However, adjustments probably will need to be made at first.
- See troubleshooting, page 18, if adjustments are needed. Once all adjustments have been made, do not change setting until all dovetails are cut.
- Repeat first six steps in this section with your finished wood.

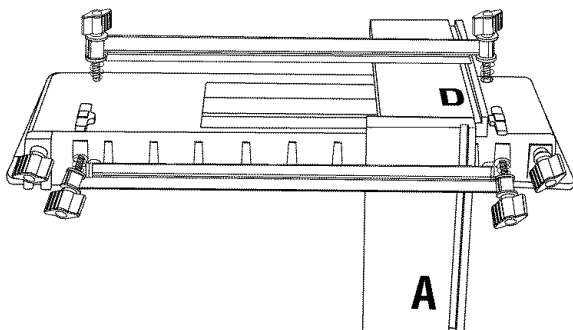


Fig. 17

You are now ready to rout your second flush dovetail joint. Do so by repeating the above procedure with boards (C) and (B) positioned against the right stops. See Figure 16.

- Insert board (C) between front clamping bar and front surface of dovetail base with bottom edge toward the right 2-way stop.
- Temporarily clamp board (C) “inside-out” to the right front of the fixture so that it extends above the base. This will assist in the proper positioning of board (B).
- Insert board (B) between top clamping bar and top surface of dovetail base, with bottom edge against right 3-way stop, and flush with extended portion of board (C).
- Tighten clamping knobs (E) on top clamping bar to hold board (B) securely.
- Relocate board (C) so that it is flush with the top of board (B) and against 2-way stop on right front of dovetail base.
- Tighten front clamping knobs (E) to hold board (C) securely.
- Attach comb-shaped template (F) and cut dovetail joint as described above.

By following the instructions just described, you have cut flush dovetail joints for a drawer front and sides. If you desire to dovetail cut the back corners, position boards (A and D) and (C and D) in the dovetail fixture as shown in figures 17 and 18. Then follow the same procedure described above.

NOTE: Once the router is set-up and all adjustments made, you can refer to figures 12, 16, 17 and 18 for proper placement of your boards each time you cut flush dovetail joints for a drawer or box.

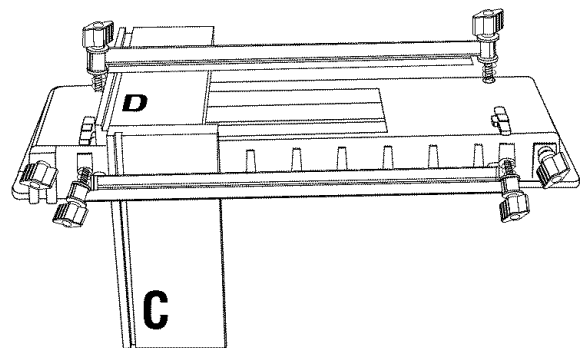


Fig. 18

OPERATION

OFFSET-FRONT DRAWER

WARNING: Unplug router from power supply while assembling parts or making adjustments. Failure to do so could result in accidental starting of the router causing damage to the work surface or possible serious personal injury.

An Offset-Front drawer, often called flush-Offset, is used when the drawer front is the same height as the drawer sides, but the drawer front is 1/8 in. longer than the width of the drawer. Therefore, the drawer sides are recessed 1/16 in. into each side of the drawer front. See Figure 2.

Set-Up

The Set-Up for an Offset-Front drawer is done exactly the same as a set-up for a flush front drawer or box, page 9, with one exception. The exception being where the angle brackets of the comb-shaped template are located on the dovetail base. See Figure 8. The angle brackets of the comb-shaped template go between spacers (G) and (H). See Figure 24.

NOTE: This set-up is used for the drawer front only. The drawer back is cut the same as a flush front drawer as described on pages 9 and 10.

- Attach guide bushing with 7/16 in. pilot diameter to router base (5/16 in. pilot diameter for 1/4 in. joints). Insert the dovetail cutter bit through the guide bushing and into chuck collet at least 3/4 in., then tighten securely. See "Installing template guide bushing and cutter", Page 7.
- Adjust the base on the router until the cutter extends 17/32 in. beyond the router subbase for 1/2 in. joints. Adjust 7/16 in. beyond the router subbase for 1/4 in. joints. See Figure 19.

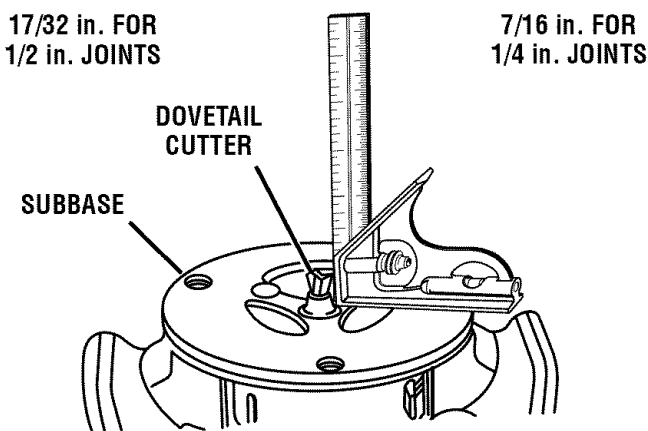


Fig. 19

- Loosen the stop screws on your dovetail base and place the 3 way stop on top and the 2 way stop on the side in their proper position. See Figures 8 and 20. Retighten stop screws securely.

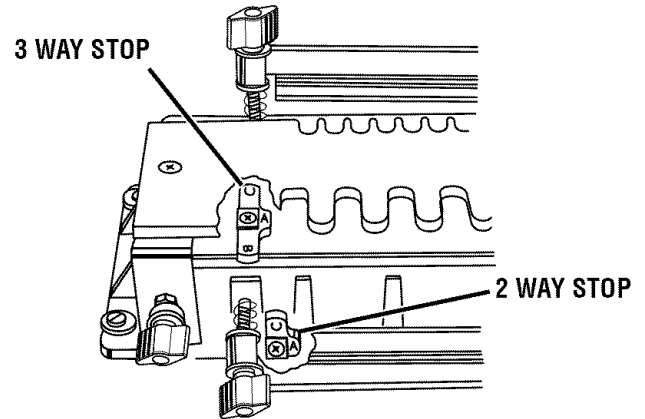


Fig. 20

- Mark the boards for the drawer or box on the inside with identifying letters near the bottom edge. See Figure 21.

NOTE: The reverse side of the board will be the outside of the finished drawer or box. The outside of the boards are always clamped towards the dovetail base and all pieces are routed in an "inside-out" position. The boards are then reversed to assemble.

NOTE: The material for front (B) and back (D) should be the same size and should be cut to fit the opening neatly. The side pieces (A and C) should also be the same size. See the chart on page 8 for computing proper sizes and recommended material thicknesses.

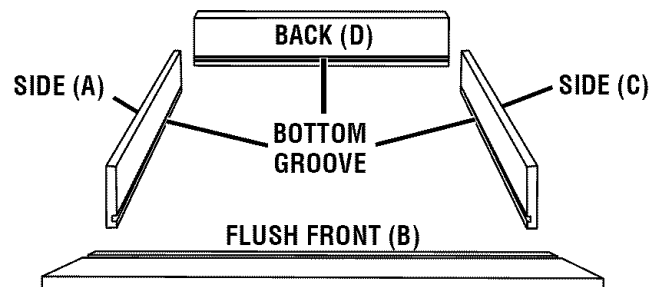


Fig. 21

OPERATION

- Insert board (A) between front clamping bar and front surface of dovetail base with bottom edge toward the left 2-way stop. Temporarily clamp board (A) “inside-out” to the left front of the fixture so that it extends above the base. See Figure 22. This is done to assist in the proper positioning of board (B).
- Insert board (B) between top clamping bar and top surface of dovetail base, with bottom edge against left 3-way stop, and flush with extended portion of board (A). See Figure 22.

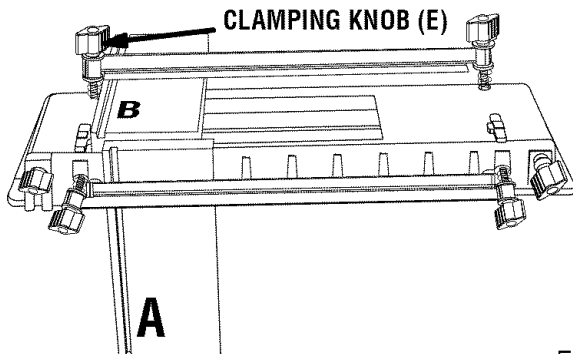


Fig. 22

- Tighten clamping knobs (E) on top clamping bar to hold board (B) securely.
- Relocate board (A) so that it is flush with the top of board (B) and against 2-way stop on left front of dovetail base. See Figure 23.
- Tighten front clamping knobs (E) to hold board (A) securely.

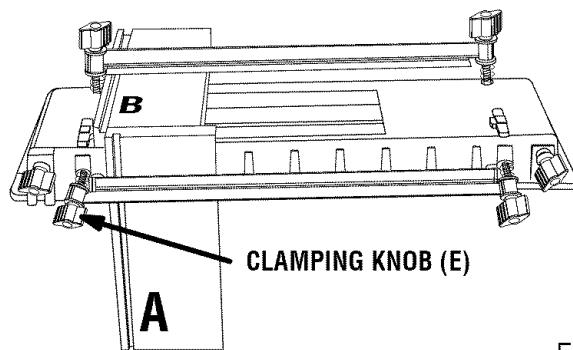


Fig. 23

- Attach comb-shaped template (F) to the dovetail base with washers (G) and spacers (H) in their desired location. See Figure 24.
- Hold the template flat on the boards with one hand, and tighten template clamping knobs (E) securely.
NOTE: Be sure template finger ends are parallel to edge of board (B) to assure even fitting after cutting.

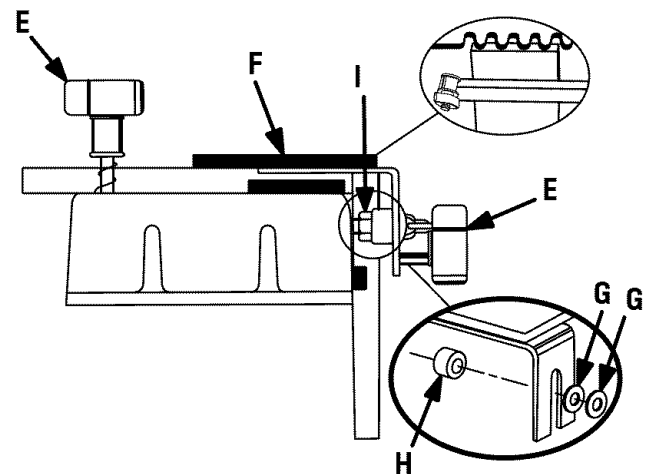


Fig. 24

Routing Your Offset-Front Joints

You are now ready to route your first offset dovetail joint. As mentioned earlier, you should make a trial cut with scrap pieces of the same wood used for the finished work. Using scrap pieces allows for adjustments to be made in the following steps.

- Place the router so that the subbase is resting flat on the dovetail template. Make sure the cutter is not making contact with the edge of board (A), then turn your router on and let the motor build to its full speed.
- Make a straight cut from **RIGHT TO LEFT** across board (A). See Figure 25. This shallow V-groove cut is made to prevent chipping of the wood when the router is moved in and out of the fingers of your dovetail template.

NOTE: When making 1/4 in. dovetails, one or two extra passes may be necessary to cut away excess stock projecting beyond the fingers of the template.

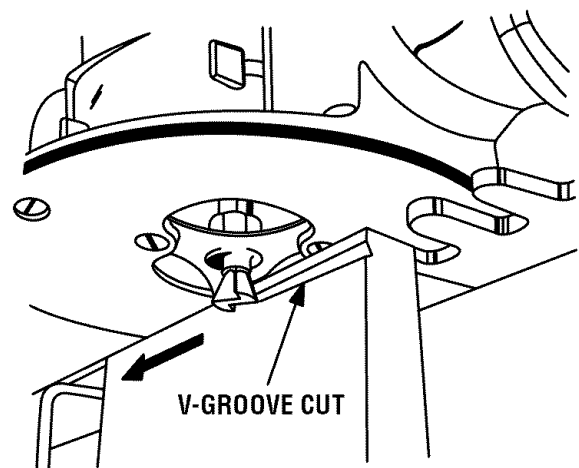


Fig. 25

OPERATION

WARNING: Use caution when operating router at either extreme end of dovetail template. The dovetail cutter will make contact with angle bracket if moved too far outside first or final cut.

- Cut the dovetail joint. Feed the router in and out each finger, moving from left to right.
- Recut the dovetail moving the router from right to left. This will clean off any spots or imperfections that might have been missed.
- To prevent possible serious injury or damage to the dovetail template, wait until the cutter has completely stopped before removing the router. When removing the router it should not be lifted but should be moved toward the operator until clear.
- Check to make sure you have routed each dovetail evenly.

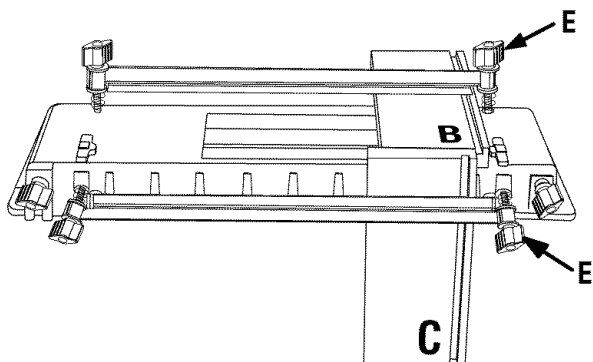


Fig. 26

- Once everything looks okay — remove the two pieces and tap them together. If properly set up, they will fit together. However, adjustments probably will need to be made at first.
- See troubleshooting, page 18, if adjustments are needed. Once all adjustments have been made, do not change setting until all dovetails are cut.
- Repeat first six steps in this section with your finished wood.

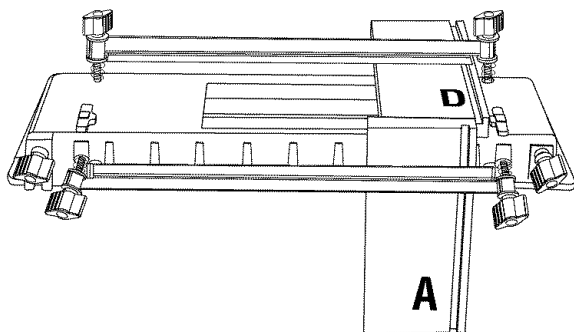


Fig. 27

You are now ready to rout your second offset dovetail joint. Do so by repeating the above procedure with boards (C) and (B) positioned against the right stops. See Figure 26.

- Insert board (C) between front clamping bar and front surface of dovetail base with bottom edge toward the right 2-way stop.
- Temporarily clamp board (C) “inside-out” to the right front of the fixture so that it extends above the base. This will assist in the proper positioning of board (B).
- Insert board (B) between top clamping bar and top surface of dovetail base, with bottom edge against right 3-way stop, and flush with extended portion of board (C).
- Tighten clamping knobs (E) on top clamping bar to hold board (B) securely.
- Relocate board (C) so that it is flush with the top of board (B) and against 2-way stop on right front of dovetail base.
- Tighten front clamping knobs (E) to hold board (C) securely.
- Attach comb-shaped template (F) and cut dovetail joint as described above.

By following the instructions just described, you have cut offset dovetail joints for a drawer front and sides. If you desire to dovetail cut the back corners, position boards (A and D) and (C and D) in the dovetail fixture as shown in figures 27 and 28, but use the comb position shown in figure 14. Then follow the same procedure described above.

NOTE: Once the router is set-up and all adjustments made, you can refer to figures 23, 26, 27 and 28 for proper placement of your boards each time you cut offset dovetail joints for a drawer or box.

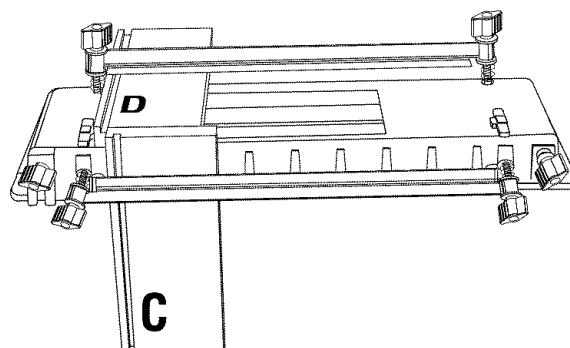


Fig. 28

OPERATION

RABBETED FRONT DRAWER

⚠ WARNING: Unplug router from power supply while assembling parts or making adjustments. Failure to do so could result in accidental starting of the router causing damage to the work surface or possible serious personal injury.

A rabbeted front drawer is used when you want the drawer front to overlap the top, bottom, and both sides of the drawer opening. The drawer front is both $\frac{3}{4}$ in. wider than the drawer sides and $\frac{3}{4}$ in. longer than the drawer width. This will give you a $\frac{3}{8}$ in. rabbet around your drawer front after you finish cutting your dovetail joints.

Set-up

- Cut a $\frac{3}{8}$ in. wide x $\frac{7}{16}$ in. deep rabbet around the drawer front.
- Attach guide bushing to your router and install dovetail cutter. See "Installing template guide bushing and cutter", Page 7.
- Adjust the base on your router until the cutter extends $\frac{17}{32}$ in. below the router subbase for $\frac{1}{2}$ in. joints.

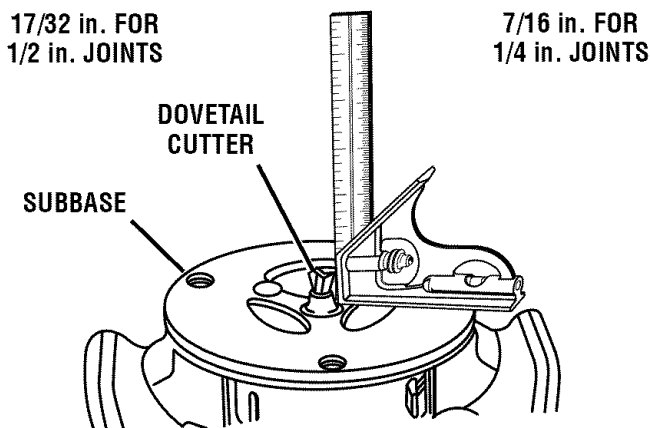


Fig. 29

Adjust $\frac{7}{16}$ in. below the router subbase for $\frac{1}{4}$ in. joints. See Figure 29.

- Loosen the stop screws in your dovetail base and place the 3-way stop on top and the 2-way stop on the side in their proper position. See Figures 8 and 30. Retighten stop screws securely.

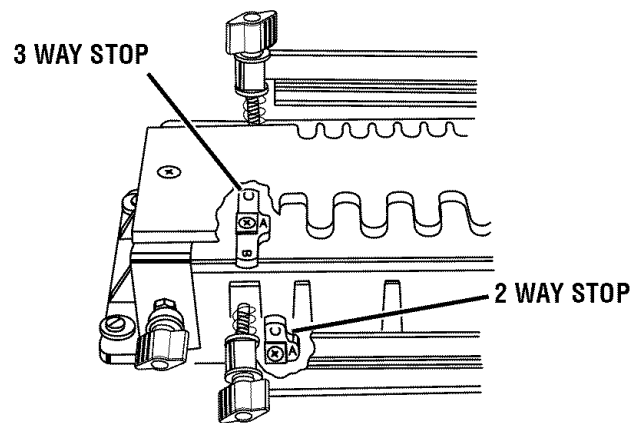


Fig. 30

- Mark the boards for the drawer or box on the inside with identifying letters near the bottom edge. See Figure 31.

NOTE: The reverse sides of the board will be the outside of the finished drawer or box. The outside of the boards are always clamped towards the dovetail base and all pieces are routed in an "inside-out" position. The boards are then reversed to assemble.

NOTE: The front piece (B) should be $\frac{3}{4}$ in. longer and $\frac{3}{4}$ in. wider than the back piece (D). The side pieces (A and C) should be the same size. See the chart on page 9 for computing proper sizes and recommended material thicknesses.

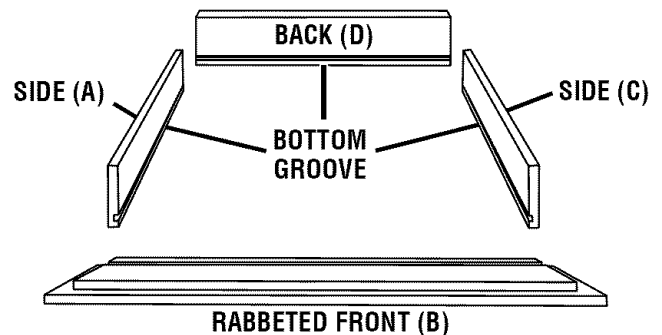


Fig. 31

OPERATION

- Insert board (A) between front clamping bar and front surface of dovetail base with bottom edge toward the left 2-way stop. Temporarily clamp board (A) “inside-out” to the left front of the fixture so that it extends above the base. See Figure 32. This is done to assist in the proper positioning of the board (B).
- Insert board (B) between top clamping bar and top surface of dovetail base, with bottom edge against left 3-way stop, and flush with extended portion of board (A). See Figure 32.

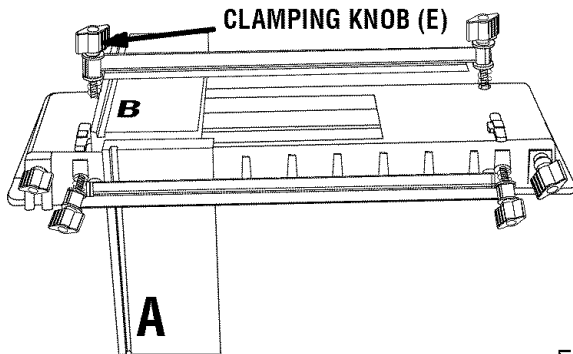


Fig. 32

- Tighten clamping knobs (E) on top clamping bar to hold board (B) securely.
- Relocate board (A) so that it is flush with the top of board (B) and against 2-way stop on left front of dovetail base. See Figure 33.

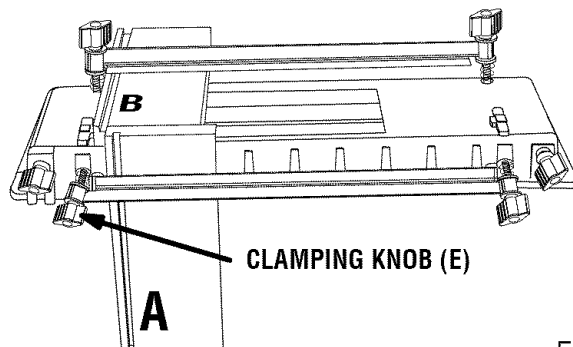


Fig. 33

- Tighten front clamping knobs (E) to hold board (A) securely.
- Attach comb-shaped template (F) to the dovetail base with spacers (G) and (H) in their desired location. See Figures 8 and 34.
- Hold the template flat on the boards with one hand and tighten template clamping knobs (E) securely.

NOTE: Be sure template finger ends are parallel to edge of board (B) to assure even fitting after cutting.

- Loosen clamping knobs (E) on top clamping bar and remove board (B) from the base and replace with a scrap piece of the same wood. This will provide support for board (A) and help prevent splintering as the cutter moves in and out of the fingers.

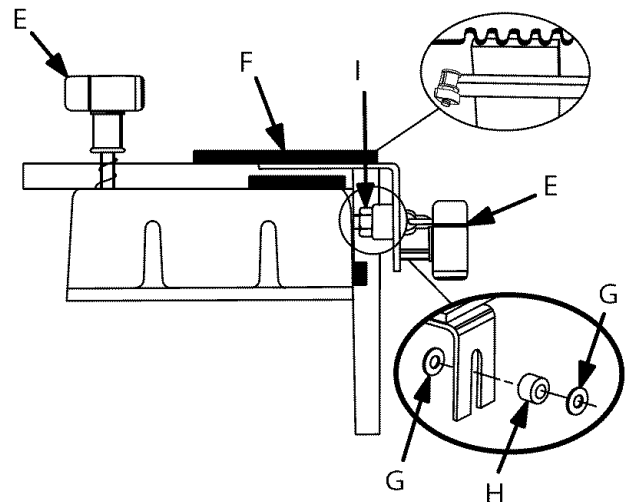


Fig. 34

Routing Your Rabbeted Dovetail Joints

You are now ready to make your cut for a rabbeted dovetail joint.

- Place the router so that the subbase is resting flat on the dovetail template. Make sure the cutter is not making contact with the edge of board (A), then turn the router on and let the motor build to its full speed.
- Make a straight cut from **RIGHT TO LEFT** across board (A). See Figure 35. This shallow V-groove cut is made to prevent chipping of the wood when the router is moved in and out of the fingers of the dovetail template.

WARNING: Use caution when operating router at either extreme end of dovetail template. Your cutter will make contact with angle bracket if moved too far outside first or final cut.

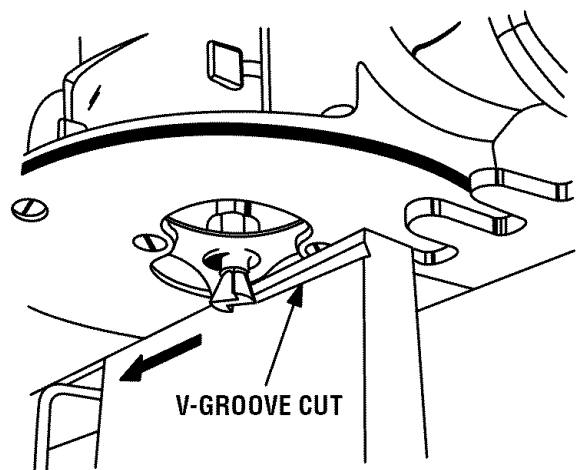


Fig. 35

OPERATION

- Cut your dovetail joint. Feed the router in and out each finger, moving from left to right.
- Recut the dovetail moving the router from right to left. This will clean off any spots or imperfections that might have been missed.
- Wait until the cutter has completely stopped before removing the router. This will prevent possible serious injury or any damage to the dovetail template. When removing the router, it should not be lifted but should be moved toward the operator until clear.
- Check to make sure you have routed each dovetail evenly.
- Loosen template clamping knobs (E) and remove comb-shaped template (F). do not remove board (A).
- Loosen clamping knobs (E) on top clamping bar and remove scrap piece of wood.
- Replace the scrap piece of wood with the piece that is to be your finished front board (B).
- Place it flush with the edge of board (A), and tighten clamping knobs (E) on top clamping bar firmly.
- Loosen clamping knobs (E) on front clamping bar and remove board (A).
- Attach comb-shaped template (F) to the dovetail base with spacers (G) and (H) in their desired location. See Figure 36. Hold the template flat on the boards with one hand and tighten clamping knobs (E) securely.

- See Figure 37. With the dovetail template set-up as shown, cut your joint in board (B) as a single piece.
- Recut the dovetail moving from right to left to clean off any spots or imperfections that might have been missed.

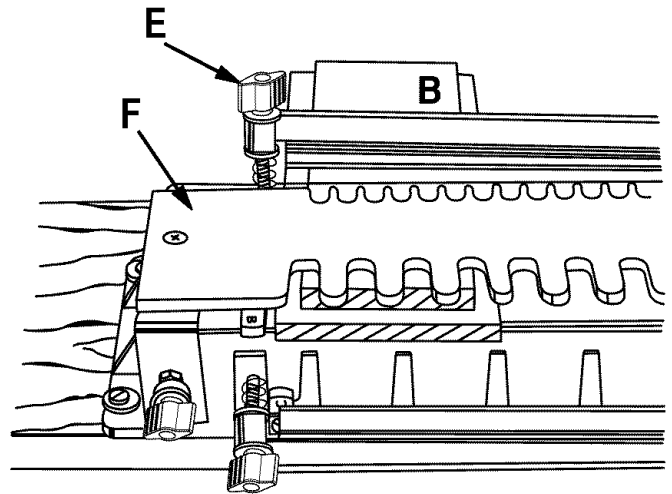


Fig. 37

To rout the other side of your rabbeted front drawer, repeat the above procedure with boards (C) and (B) positioned against the right stops. See Figure 38. To rout dovetail cuts in board (D) and boards (A and C) follow the instructions for making a “flush front drawer or box” on pages 10 and 11.

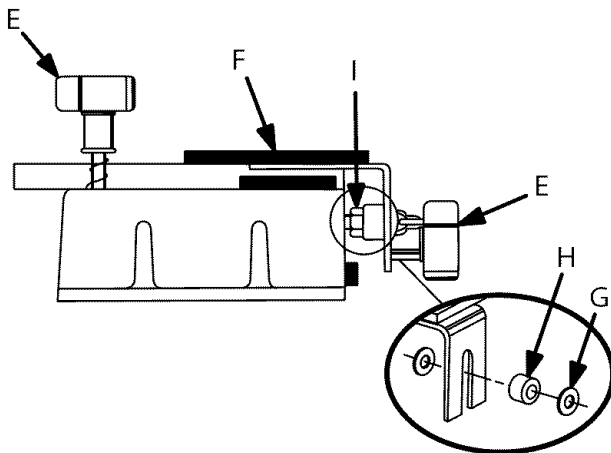


Fig. 36

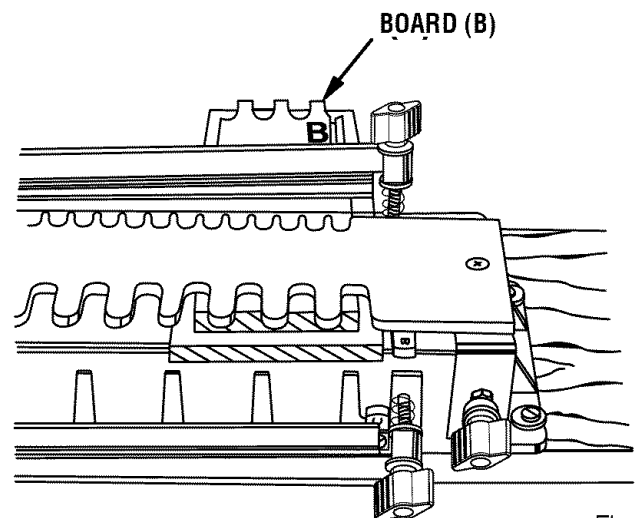


Fig. 38

OPERATION

HELPFUL HINTS

- Once all adjustments are made, do not make any further changes until all dovetails are cut.
- Always clamp workpiece securely for cutting.
- Rout dovetails from the front only.
- A safe operator is one who thinks ahead.
- Do not raise or lower your router or cutter while the bit is between the dovetail template fingers.
- Keep router base flat against template.
- Always wear eye protection when routing.
- Make certain the ends of all boards are square.
- Make set-up adjustments carefully. Then double check. Measure twice and cut once.
- **DO NOT** use warped boards.
- Keep cutters clean and properly sharpened.
- Be consistent when selecting the thickness of your boards.
- Don't let familiarity make you careless.
- Always bevel the drawer front for an offset-front drawer.
- Study all safety rules and do the job safely.
- Plan your drawer height opening so that the boards will be in increments of 7/8 in. for 1/2 in. joints, or 29/64 in. increments for 1/4 in. joints. This will allow a half-pin to be on both the top and bottom edge of the drawer front. Don't forget to allow for clearances.
- **NEVER** place your hands in jeopardy.
- Make certain clamps can't loosen while in use.
- Test difficult set-ups on scrap — Don't waste lumber.
- Plan each operation before you begin.
- **THINK SAFETY BY THINKING AHEAD.**

TROUBLESHOOTING

PROBLEM

SOLUTION

If the joint is too tight

Raise the cutter very slightly. This will make the cut more shallow (approximately 1/64 in.). See depth adjustment instructions as explained in the router operator's manual.

If the joint is too loose

Lower the cutter bit very slightly to make the cut deeper (approximately 1/64 in.).

If the fit is too deep

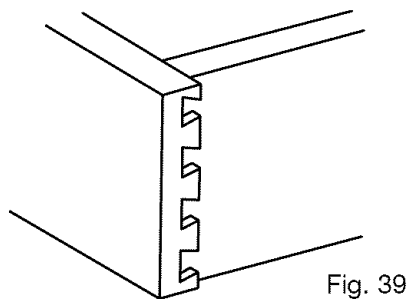


Fig. 39

Turn the lock nut (l) in a counter-clockwise direction until desired depth is reached. See *Figures 14, 17, or 18*. **NOTE:** Be sure to adjust both lock nuts equally.

If the fit is too shallow

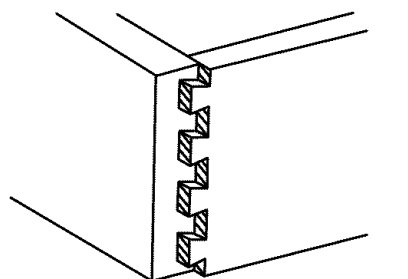


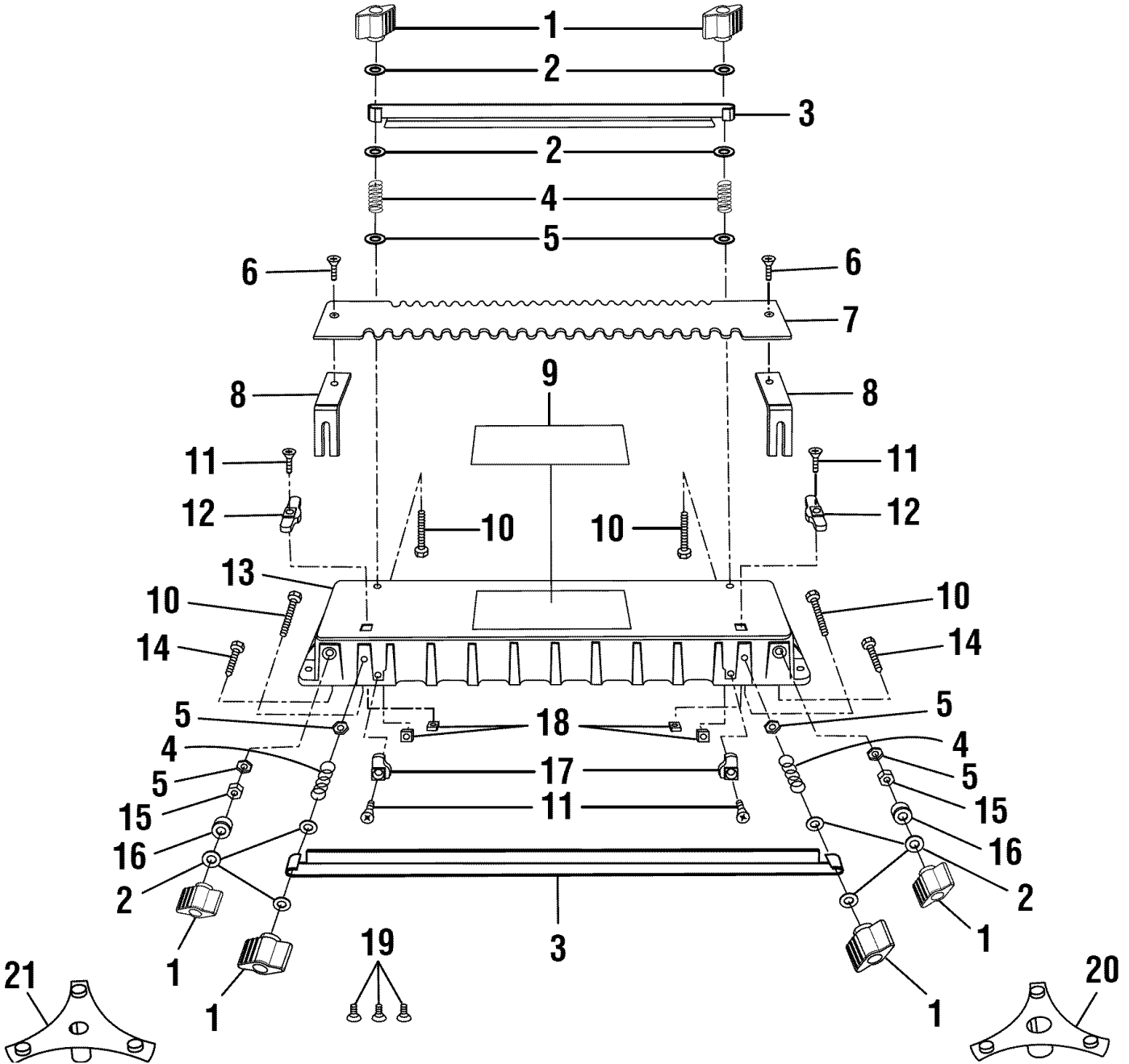
Fig. 40

Turn the lock nut (l) in a clockwise direction until the desired depth is reached. **NOTE:** Be sure to adjust both lock nuts equally.

CRAFTSMAN PRODUCT NAME – MODEL NUMBER 315.25791

The model number will be found on a plate attached to the motor housing. Always mention the model number in all correspondence regarding your accessory or when ordering repair parts.

SEE BACK PAGE FOR PARTS ORDERING INSTRUCTIONS



* Standard Hardware Item – May Be Purchased Locally

** Available From Div. 98 – Source 980.0

*** Complete assortment available at your Nearest Sears Retail Store

CRAFTSMAN PRODUCT NAME – MODEL NUMBER 315.25791

The model number will be found on a label attached to the base. Always mention the model number in all correspondence regarding your accessory or when ordering repair parts.

SEE BACK PAGE FOR PARTS ORDERING INSTRUCTIONS

PARTS LIST

Key No.	Part Number	Description	Qty.
1	000900067001	Clamping Knob	6
2	000900067002	Washer	12
3	000900067003	Clamp Bar	2
4	000900067004	Spring.....	4
5	000900067005	Nut (1/4-20)	6
6	000900067006	* Screw (#10-32 x 1/2 in. Flat Head Thread Cutting).....	2
7	000900067007	Template.....	1
8	000900067008	Angle Bracket.....	2
9	000900067009	Label.....	1
10	000900067010	Hex Bolt (1/4-20 x 3 in.)	4
11	000900067011	* Screw (#8-32 x 7/8 in. Flat Head).....	4
12	000900067012	3 Way Stop.....	2
13	000900067013	Base	1
14	000900067014	Hex Bolt (#1/4-20 x 1-3/4 in.).....	2
15	000900067015	Lock Nut (#1/4-20)	2
16	000900067016	Spacer.....	2
17	000900067017	2 Way Stop.....	2
18	000900067018	Square Nut (#8-32) **STD541008	4
19	000900067021	* Screw (#10-32 x 7/8 in. Flat Head).....	3
20	000900067019	7/16 in. Guide Bushing.....	1
21	000900067020	5/16 in. Guide Bushing.....	1
22		Data Label (Not Shown)	1
	983000533	Operator's Manual	

* Standard Hardware Item – May Be Purchased Locally

** Available From Div. 98 – Source 980.0

*** Complete assortment available at your Nearest Sears Retail Store

Free Manuals Download Website

<http://myh66.com>

<http://usermanuals.us>

<http://www.somanuals.com>

<http://www.4manuals.cc>

<http://www.manual-lib.com>

<http://www.404manual.com>

<http://www.luxmanual.com>

<http://aubethermostatmanual.com>

Golf course search by state

<http://golfingnear.com>

Email search by domain

<http://emailbydomain.com>

Auto manuals search

<http://auto.somanuals.com>

TV manuals search

<http://tv.somanuals.com>