

Operator's Manual

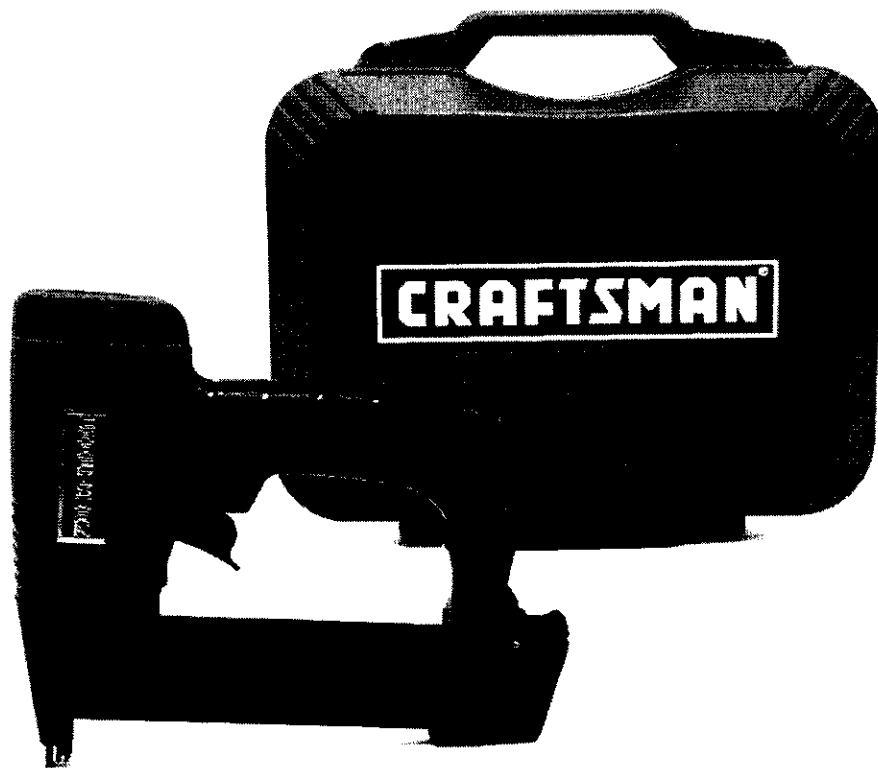

18 Gauge
 $\frac{3}{8}$ - $1\frac{3}{8}$ " Length
BRAD NAILER

Model No.
351.181730



CAUTION: Read and follow all Safety Rules and Operating Instructions before First Use of this Product. Keep this manual with tool.

- Safety
- Operation
- Maintenance
- Parts List
- Español

Sears, Roebuck and Co., Hoffman Estates, IL 60179 U.S.A.

www.sears.com/craftsman

20347.01 Draft (04/30/03)

TABLE OF CONTENTS

| | |
|---------------------------------------|-------|
| Warranty | 2 |
| Safety Rules | 2 |
| Operation | 3-5 |
| Maintenance | 5-6 |
| Troubleshooting | 7 |
| Parts Illustration and List | 8-9 |
| Español | 10-15 |

WARRANTY

FULL ONE YEAR WARRANTY

If this product fails due to a defect in material or workmanship within one year from the date of purchase, Sears will at its option repair or replace it free of charge. Contact your nearest Sears Service Center (1-800-4-MY-HOME) to arrange for product repair, or return this product to place of purchase for replacement.

If this product is used for commercial or rental purposes, this warranty will apply for 90 days from the date of purchase.

This warranty applies only while this product is used in the United States.

This warranty gives you specific legal rights, and you may also have other rights which vary from state to state.

Sears, Roebuck and Co., Dept. 817WA, Hoffman Estates, IL 60179

SAFETY RULES

- Read and follow all safety rules and operating instructions in this manual and on warning label of tool before using this tool. Keep this manual with the tool.
- Keep work area clean and properly lighted.
- Keep children, bystanders and visitors at a safe distance from work area while operating this tool.
- Air tool operators and all others in work area should always wear safety goggles complying with United States ANSI Z87.1 to prevent eye injury from fasteners and flying debris when loading, operating and unloading this tool. Everyday eyeglasses have only impact resistant lenses. These are NOT safety glasses. ANSI Z87.1 safety glasses have permanently attached rigid, hard plastic side shields and will have "Z87.1" printed or stamped on them.
- Always wear ear protection. The work area may include exposure to excessive noise levels which will require necessary ear protection. Some environments will require head protection; use head protection conforming to ANSI Z89.1.
- Do not alter or modify this tool in any way. Do not use this tool for any application other than for which it was designed.
- Do not use oxygen, carbon dioxide, high-pressure compressed gas or bottled gases as the power source for this tool. The tool will explode and serious personal injury could result.
- Never connect the tool to air pressure which could potentially exceed 200 psi. Use only clean, dry, regulated air within rated range as marked on tool.

- The tool must have a male, free-flow hose coupling so that all air pressure is removed from the tool when the coupling joint is disconnected. Failure to use proper coupling could cause accidental discharge, possibly causing injury.
- Only use air hose that is rated for a maximum working pressure of 150 psi or 150% of the maximum system pressure, whichever is greater.
- Do not use a hose swivel connector with this tool.
- Do not pull trigger or depress contact trip while connecting to the air supply, as the tool may cycle, possibly causing injury.
- When loading tool: Do not pull trigger or depress contact trip; Do not point the tool at yourself or others; Do not place hand or any part of body in the fastener discharge area of the tool as accidental actuation may occur and cause injury.
- Disconnect tool from air supply before loading or unloading, performing tool maintenance, clearing a jammed fastener, leaving work area, moving tool to another location or handing the tool to another person.
- Use Sears recommended fasteners only.
- Do not load the tool until you are ready to use it.
- Always assume that the tool contains fasteners. Keep the tool pointed away from yourself and others at all times. Never engage in horseplay. Never pull the trigger unless the contact trip is in contact with the workpiece. Keep others at a safe distance from the tool while the tool is in operation.
- Always remove finger from trigger when not driving fasteners. Never carry the tool with finger on or under the trigger as accidental actuation may occur and cause injury.
- Always keep hands and body away from the fastener discharge area when air supply is connected to the tool. Grip tool firmly to maintain control while allowing tool to recoil away from work surface as fastener is driven. If contact trip is allowed to recontact work surface before trigger is released, an unwanted fastener may be driven.
- Check operation of the contact trip frequently. Never use the tool if the contact trip, trigger or springs have become inoperable, missing or damaged. Do not alter or remove contact trip, trigger or springs. Never use a tool that is leaking air, has missing or damaged parts, or requires repair.
- Do not drive fasteners on top of other fasteners or with the tool at too steep an angle. The fasteners can ricochet and cause injury. Do not drive fasteners close to the edge of the workpiece. The workpiece is likely to split, allowing the fastener to fly free and cause injury. Do not attempt to drive fasteners into hard or brittle materials such as concrete, steel or tile.
- Do not overreach. Always place yourself in a firmly balanced position when using or handling the tool. Do not attach the hose or tool to your body.
- Do not operate tool without fasteners or damage to tool may result.
- Do not use tool without safety warning label. If label is missing, damaged or unreadable, contact SEARS to obtain a new label.
- Only qualified repair personnel must perform tool service.
- When servicing a tool, use only identical repair parts.
- Store tool out of reach of children and other untrained persons.

OPERATION

DESCRIPTION

The Craftsman 18 Gauge Brad Nailer drives brads from $\frac{3}{8}$ " to $1\frac{3}{8}$ " long. Oilless design eliminates daily oiling and oil stains on workpiece. Die cast magnesium body with textured rubber grip minimizes operator fatigue. Large capacity, side loading magazine with positive, quick action latch makes loading easy. Nailer features rear exhaust, single and rapid-fire operation, adjustable depth of drive control, rubber nose tip and storage case. Safety feature disables tool unless contact trip is pressed against workpiece. Tapered nosepiece provides operator with greater visibility for precise fastener placement. Rigid nosepiece reduces jamming. The 18 Gauge Brad Nailer is excellent for molding, furniture making, and picture framing.

SPECIFICATIONS

| | |
|--------------------|-------------------------------------|
| Capacity | 100 brad nails |
| Nail size | 18 gauge (.049" x .040") |
| Nail lengths | $\frac{3}{8}$ " to $1\frac{3}{8}$ " |
| Operating pressure | 60-100 PSI |
| Air inlet | $\frac{1}{4}$ " N.P.T. |
| Length | $9\frac{9}{16}$ " |
| Height | $7\frac{3}{4}$ " |
| Width | $2\frac{3}{16}$ " |
| Weight | 2.7 lbs. |

BRAD NAILS

| | |
|---------------------|--|
| 18340 (Box of 5000) | 18 gauge brad nails, $\frac{3}{8}$ " long |
| 18341 (Box of 5000) | 18 gauge brad nails, $\frac{5}{8}$ " long |
| 19171 (Box of 1000) | 18 gauge brad nails, $\frac{5}{8}$ " long |
| 18342 (Box of 5000) | 18 gauge brad nails, 1" long |
| 19172 (Box of 1000) | 18 gauge brad nails, 1" long |
| 18343 (Box of 5000) | 18 gauge brad nails, $1\frac{1}{4}$ " long |
| 19173 (Box of 1000) | 18 gauge brad nails, $1\frac{1}{4}$ " long |

AIR SUPPLY LINE

Refer to Figure 1.

DANGER: Do not use oxygen, carbon dioxide, high-pressure compressed gas or bottled gases as the power source for this tool. The tool will explode and serious personal injury could result.

- The air tool operates on compressed air at pressures from 60 to 100 PSI.
- Never connect the tool to air pressure which could potentially exceed 200 PSI. Use only clean, dry, regulated air within rated range as marked on tool.

Air Delivery Required: 0.85 SCFM @ 90 PSI (30 shots per minute).

WARNING: Keep hands and body away from discharge area of tool when connecting air supply. Always disconnect tool from air supply when servicing or adjusting tool and when tool is not in use.

- Air operated tools require clean, dry, lubricated compressed air to ensure top performance, low maintenance and long life.

- Dirt and abrasive materials present in all air lines will damage tool O-rings, valves and cylinders.
- Moisture will reduce tool performance and life if not removed from compressed air.
- A filter-regulator-lubricator system is required and should be located as close to tool as possible. A distance of less than 15 feet is recommended. Lubricator is not required for oilless tools.
- Keep air filter clean. A dirty filter will reduce the air pressure to the tool causing a reduction in power and efficiency.
- The air supply system must be able to provide air pressure of 60 to 100 pounds per square inch at tool.
- All hoses and pipes in the air supply system must be clean and free of moisture and foreign particles. Hoses must be rated for a maximum working pressure of 150 PSI or 150% of maximum system pressure, whichever is greater.
- Do not mount swivel connector in air supply line.
- The air pressure should be properly regulated.
- Different workpiece materials and different fastener lengths will require different operating pressure.
- Be sure all connections in air supply system are sealed to prevent air loss.
- Never connect a female quick-disconnect coupling to the tool side of air line connection. A male, free-flow coupling should be connected to the tool side of air line connection (see Figure 1).

WARNING: The female coupling provides a seal preventing loss of compressed air from compressor tank when disconnected from male coupling. If connected to tool side of air supply, the female coupling could seal a compressed air charge in the tool which could discharge if the tool trigger is actuated.

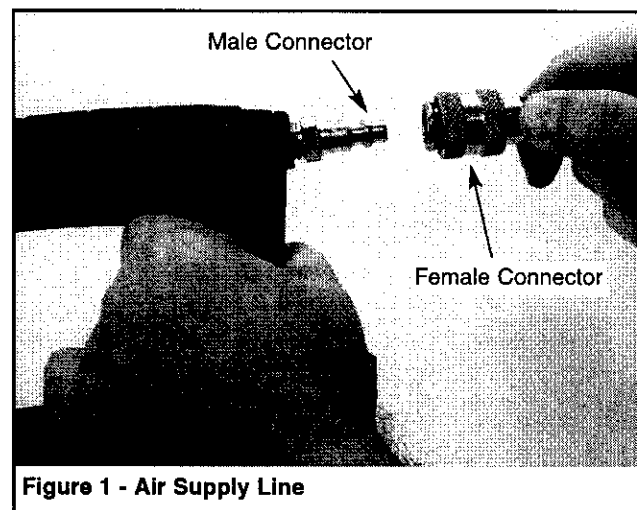

Figure 1 - Air Supply Line

LOADING

Refer to Figures 2, 3 & 4 (page 4).

WARNING: Disconnect tool from air supply. Do not load tool until you are ready to use it. Do not pull trigger or depress contact trip while loading tool. Always load with nose of tool pointing away from you and others. Always wear safety goggles that comply with United States ANSI Z87.1.

NOTE: For best results, use Sears fasteners only.

- Depress latch and slide magazine cover open (see Figure 2).

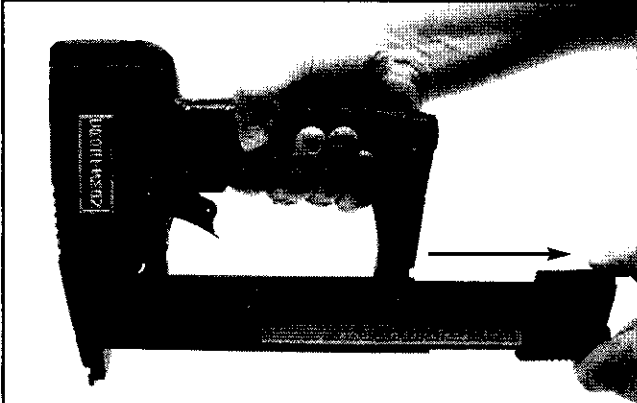

Figure 2 - Open Magazine

- Insert fasteners into magazine. Position fasteners at bottom of magazine with head towards top of tool (see Figure 3).

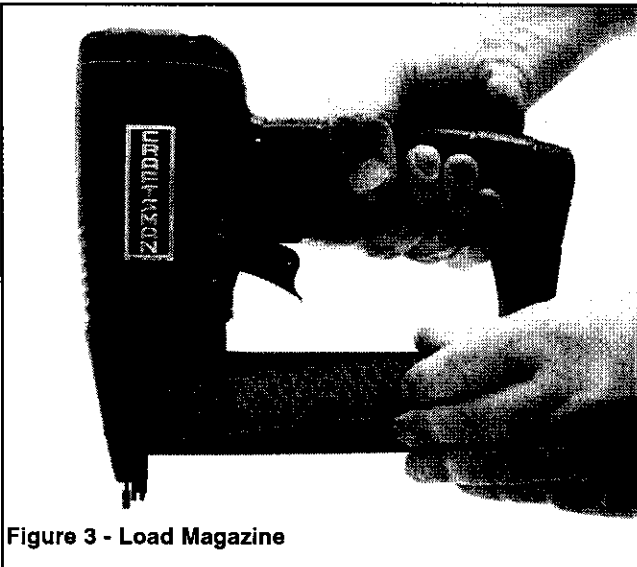

Figure 3 - Load Magazine

- Slide magazine cover forward over magazine until latch snaps into place, locking magazine cover (see Figure 4).

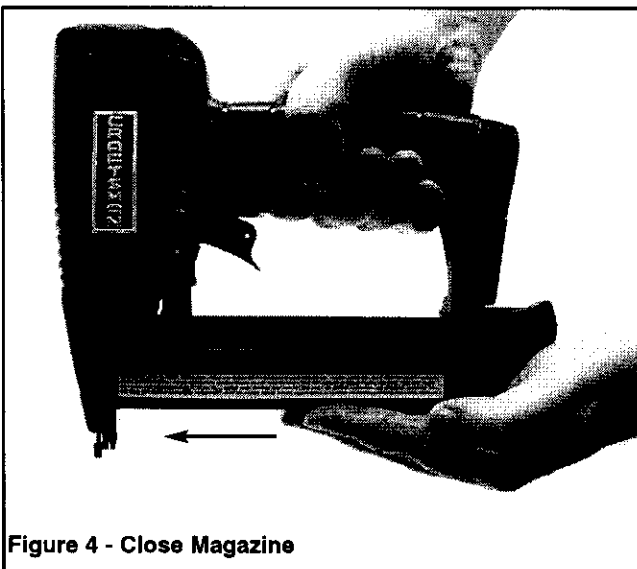

Figure 4 - Close Magazine

NAILING OPERATION

Refer to Figures 5, 6, 7 & 8 (pages 4 and 5).

WARNING: Read and follow all safety rules and operating instructions in this manual and on warning label of tool before using this tool. Keep this manual with the tool.

WARNING: Do not use this tool without safety warning label. If label is missing, damaged or unreadable, contact Sears to obtain a new label.

WARNING: Never operate tool unless contact trip is in contact with workpiece. Do not operate tool without fasteners or damage to tool may result. Never fire fasteners into the air because fasteners may injure operator or others and damage to tool may result.

- Perform "Safety Mechanism Check" as described in the Maintenance section (see page 6) prior to first use of tool and on a daily basis thereafter.
- The tool is equipped with a rotating switch that can be set to rapid-fire or single-fire mode (see Figure 5). When the switch is set to single-fire mode, the tool will not drive a second fastener until the trigger is fully released and pulled again.
- When the switch is rotated to rapid-fire mode, the tool can drive fasteners continuously. A fastener will be fired each time the contact trip is pressed against the workpiece, as long as the trigger is maintained in the pulled position.

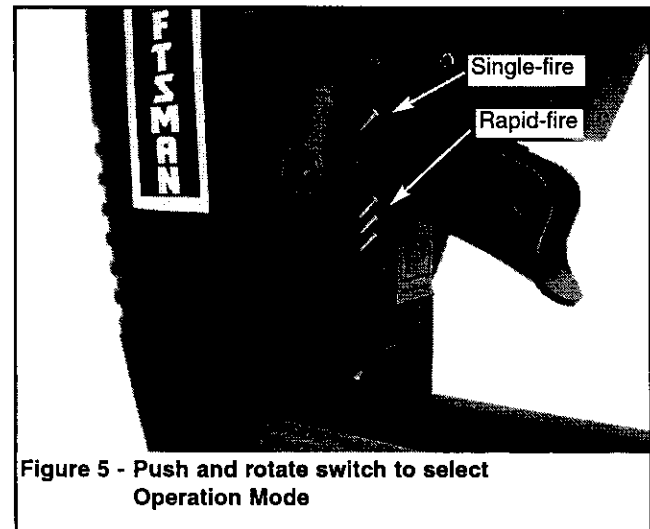

Figure 5 - Push and rotate switch to select Operation Mode

SINGLE-FIRE OPERATION:

- The air tool is equipped with a contact trip safety mechanism that disables tool unless contact trip is pushed against work. To drive a fastener hold body firmly and press contact trip on workpiece where fastener is to be applied. Pull trigger to drive fastener into workpiece. To fire a second fastener lift the tool from the workpiece, release the trigger and then repeat the above sequence.

RAPID-FIRE OPERATION:

- The tool can also be operated by holding trigger depressed and pushing contact trip against workpiece. A fastener will be driven each time the contact trip is pushed against the workpiece. This operating procedure provides rapid-fire fastener driving. Never operate tool unless contact trip is in contact with workpiece.

WARNING: All air power fastening tools recoil when operated. This recoil is caused by rapid driving of the fastener. Tool may bounce from recoil causing a second unwanted fastener to be driven. Reduce tool bounce by holding tool firmly in hand and pressing tool gently against workpiece. Let the tool do the work. This will allow recoil of tool to bounce tool away from workpiece preventing the driving of second fastener.

CONTACT TRIP ADJUSTMENT

The contact trip may be adjusted up or down to vary the depth of the fastener in the workpiece. To adjust, rotate depth control knob (see Figure 6) to raise or lower contact trip to desired setting.

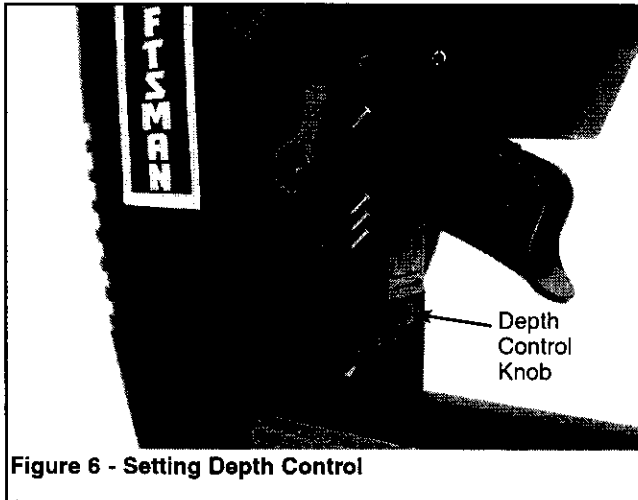

CONTACT TRIP PAD

The tool is equipped with a contact trip pad (see Figure 7) that prevents marring of finished surfaces by the contact trip during normal operation. Pad can be removed and stored on the storage sleeve located on the end cover of the magazine. Hex wrench is also stored on the magazine.

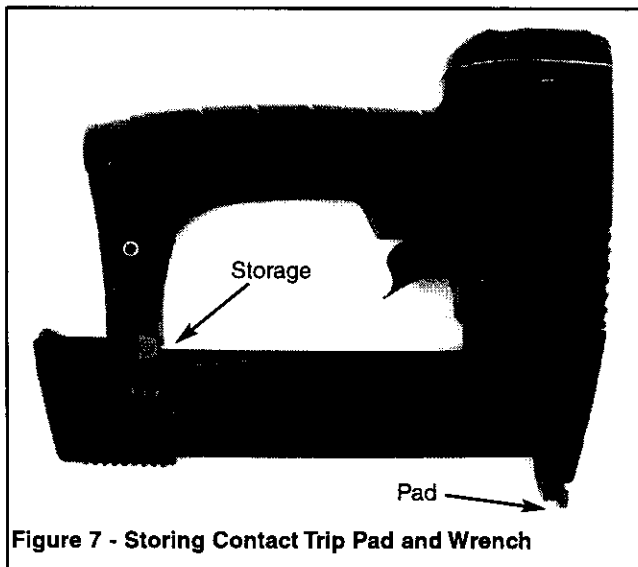

LOAD INDICATOR

The tool is equipped with a load indicator. The load indicator (colored red) will be visible through the magazine cover window when there are no fasteners in the magazine.

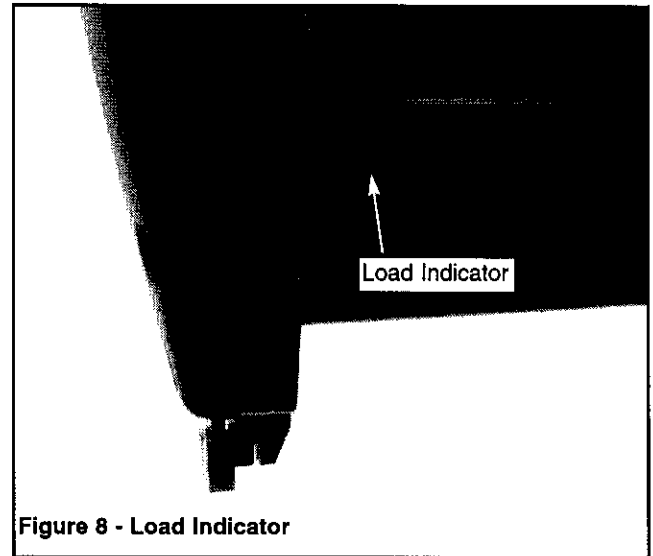

OPERATING PRESSURE

- Use only enough air pressure to perform the operation. Air pressure in excess of that which is required will make the operation inefficient and may cause premature wear or damage to the tool.
- Determine minimum air pressure required by driving some test fasteners into the workpiece. Set air pressure so that test fasteners are driven down flush with the work surface. Fasteners driven too deep may damage workpiece.

COLD WEATHER OPERATION

CAUTION: Do not store in cold environment. Frost or ice could form inside tool affecting operation and damaging tool. Use a cold temperature lubricant, such as ethylene glycol, when operating tool in freezing temperatures.

MAINTENANCE

Refer to Figure 9 (page 8).

LUBRICATION

This is an oilless tool. No lubrication is necessary.

MAGAZINE AND PISTON-RAM

- Keep magazine and nose of tool clean and free of any dirt, lint or abrasive particles.

The tip of the ram (Fig. 9, No. 11) can become dented or rounded over time.

- Square off the tip of the ram with a clean, fine hand file to extend the life of the ram and tool. Fastener firing will be more consistent if the ram tip is kept clean and square.

SAFETY MECHANISM CHECK

Inspect contact trip safety mechanism daily for proper operation. Do not operate tool if mechanism is not operating properly.

With the red push-button switch in the rapid-fire mode, perform the following procedures to test safety mechanism:

- Leave trigger untouched while pushing contact trip into workpiece. **Tool must not fire.**
- Pull trigger while contact trip is clear of work and pointed away from operator and others. **Tool must not fire.**
- Depress and hold trigger. Push contact trip against work where fastener is needed. The tool should drive only one fastener each time the contact trip is pushed against workpiece.

If contact trip mechanism does not operate properly, repair tool immediately through Sears Service Center.

Replace any damaged or missing parts. Use the parts list to order parts.

REBUILD KITS

Rebuild kits are available as spare parts, (see page 9). Tools should be rebuilt if tool fails to operate properly after extended use. See troubleshooting to determine required replacement parts.

Disconnect tool from air supply before attempting repair or adjustment.

NOTE: When replacing O-rings or cylinder, lubricate with grease before assembly.

TROUBLESHOOTING

| SYMPTOM | POSSIBLE CAUSE(S) | CORRECTIVE ACTION |
|--|--|---|
| Trigger cap leaks air | <ol style="list-style-type: none"> 1. O-ring damaged 2. Valve stem, seal or O-rings damaged | <ol style="list-style-type: none"> 1. Check and replace damaged O-ring (Fig. 9, No. 55) 2. Check and replace damaged stem, seal or O-rings (Fig. 9, Nos. 55, 56, 57 and 60) |
| Cap leaks air | <ol style="list-style-type: none"> 1. Cap bolts loose 2. Damaged gasket | <ol style="list-style-type: none"> 1. Tighten bolts (Fig. 9, No. 1) 2. Check and replace damaged gasket (Fig. 9, No. 3) |
| Nose leaks air | <ol style="list-style-type: none"> 1. Damaged cylinder O-ring 2. Damaged bumper 3. Ram guide damaged | <ol style="list-style-type: none"> 1. Check and replace damaged O-ring (Fig. 9, No. 12) 2. Check and replace damaged bumper (Fig. 9, No. 14) 3. Check and replace guide (Fig. 9, No. 15) |
| Tool will not operate | <ol style="list-style-type: none"> 1. Insufficient air supply 2. Damaged or worn head valve O-ring or seal 3. Damaged head valve spring 4. Head valve binding in cap | <ol style="list-style-type: none"> 1. Check air supply 2. Replace damaged or worn O-ring or seal (Fig. 9, Nos. 5 and 9) 3. Replace damaged spring (Fig. 9, No. 6) 4. Clean and grease cap and head valve (Fig. 9, Nos. 2 and 9) |
| Tool operates slowly or loses power | <ol style="list-style-type: none"> 1. Damaged head valve spring 2. Damaged or worn O-rings 3. Damaged trigger assembly 4. Build-up on ram 5. Cylinder not sealed on bumper properly 6. Insufficient air supply 7. Head valve poorly lubricated | <ol style="list-style-type: none"> 1. Check and replace damaged spring (Fig. 9, No. 6) 2. Check and replace damaged or worn O-rings 3. Check and replace trigger assembly 4. Clean piston/ram assembly (Fig. 9, No. 11) 5. Disassemble cylinder and assemble properly 6. Check air supply 7. Disassemble head valve (Fig. 9, No. 9), clean, grease, and assemble properly |
| Tool skips fasteners or inconsistent operation | <ol style="list-style-type: none"> 1. Worn or damaged bumper 2. Build-up on ram or nose 3. Insufficient air supply 4. Damaged or worn piston O-ring 5. Damaged magazine springs 6. Magazine-nose bolts loose 7. Fasteners too short 8. Damaged fasteners 9. Incorrect fastener size 10. Cap leaks 11. Damaged trigger valve seal and O-rings 12. Bent or damaged ram 13. Dirty magazine 14. Damaged or worn magazine | <ol style="list-style-type: none"> 1. Check and replace bumper (Fig. 9, No. 14) 2. Clean and grease piston/ram assembly (Fig. 9, No. 11) and inside of nose cover (Fig. 9, No. 21) 3. Check air supply 4. Check and replace O-ring (Fig. 9, No. 10) 5. Check and replace springs (Fig. 9, No. 34) 6. Align nose with magazine and tighten bolts (Fig. 9, No. 24) 7. Use Sears recommended fasteners only 8. Discard damaged fasteners 9. Use Sears recommended fasteners only 10. Tighten cap bolts (Fig. 9, No. 1). Check and replace damaged gasket (Fig. 9, No. 3) 11. Check and replace damaged seal and O-rings (Fig. 9, Nos. 55, 57 and 60) 12. Check and replace damaged piston/ram assembly (Fig. 9, No. 11) 13. Clean magazine and lubricate with a dry, film lubricant. 14. Check and replace magazine (Fig. 9, No. 37) |

Model 351.181730

Figure 9 - Replacement Parts Illustration For Nailer

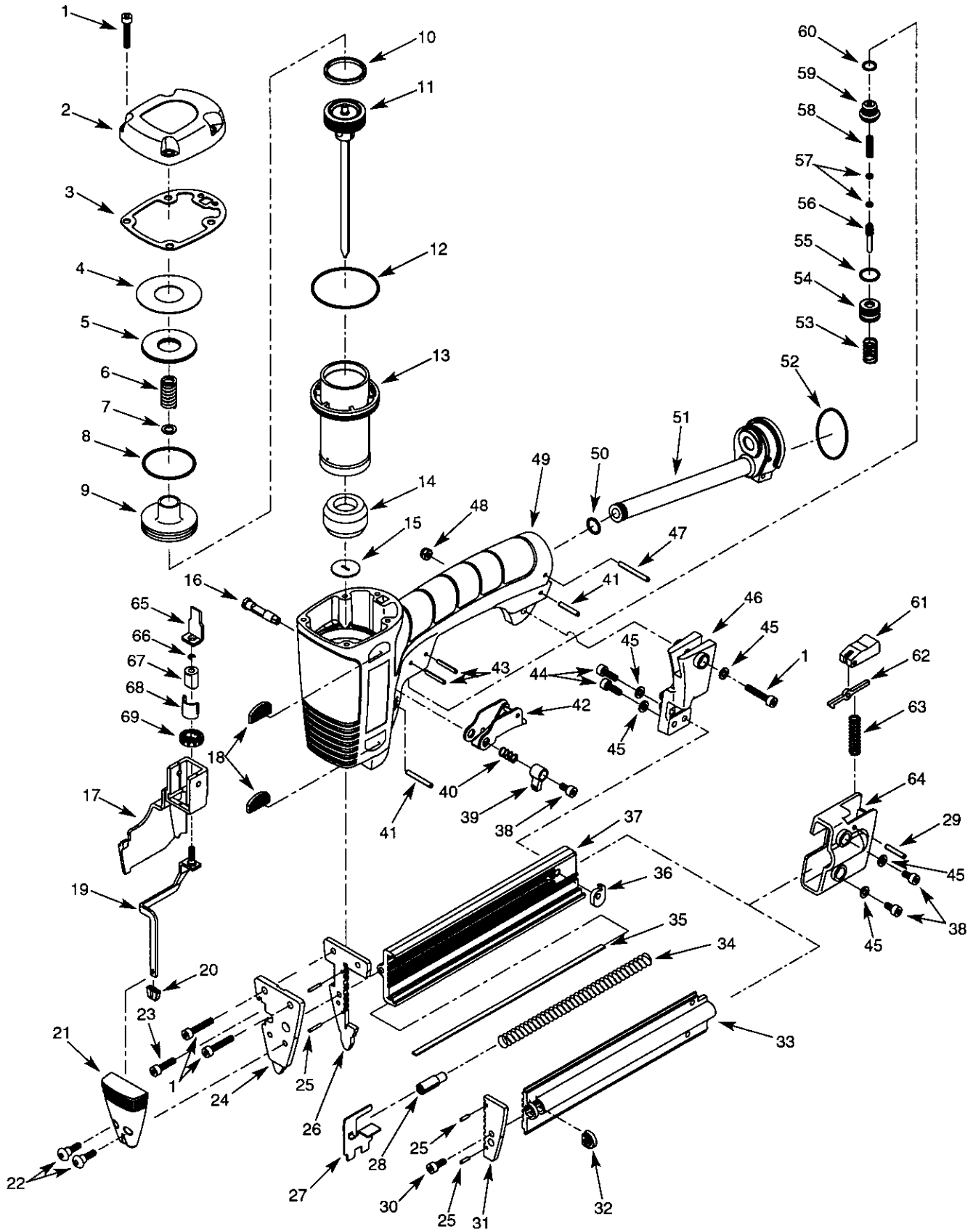

REPLACEMENT PARTS LIST FOR NAILER

| KEY NO. | PART NO. | DESCRIPTION | QTY. |
|---------|----------|-------------------------------|------|
| 1 | 06395.00 | 4-0.7 x 22mm Socket Head Bolt | 7 |
| 2 | 20333.00 | Cap | 1 |
| 3 | 20273.00 | Cap Gasket | 1 |
| 4 | 20274.00 | Spacer | 1 |
| 5 | 20275.00 | Seal | 1 |
| 6 | 04210.00 | Head Valve Spring | 1 |
| 7 | 06436.00 | Spacer | 1 |
| 8 | 04303.00 | 33.5 x 2.0mm O-Ring | 1 |
| 9 | 04302.00 | Head Valve Piston | 1 |
| 10 | 20277.00 | Seal | 1 |
| 11 | 20334.00 | Piston Ram Assembly | 1 |
| 12 | 06909.00 | 44.17 x 1.78mm O-Ring | 1 |
| 13 | 20335.00 | Cylinder | 1 |
| 14 | 20280.00 | Bumper | 1 |
| 15 | 20281.00 | Ram Guide | 1 |
| 16 | 20282.00 | Throttle | 1 |
| 17 | 20336.00 | Contact Trip Guide | 1 |
| 18 | 20284.00 | Pad | 4 |
| 19 | 20337.00 | Contact Trip | 1 |
| 20 | 20286.00 | Contact Trip Pad | 1 |
| 21 | 20338.00 | Nose Cover | 1 |
| 22 | 04345.00 | Shoulder Screw | 2 |
| 23 | 06079.00 | 4-0.7 x 16mm Socket Head Bolt | 1 |
| 24 | 20339.00 | Nose | 1 |
| 25 | 20895.00 | 2 x 12mm Spring Pin | 4 |
| 26 | 20340.00 | Left Plate | 1 |
| 27 | 20341.00 | Pusher | 1 |
| 28 | 20291.00 | Load Indicator | 1 |
| 29 | 01939.00 | 3 x 20mm Spring Pin | 1 |
| 30 | 06088.00 | 4-0.7 x 10mm Socket Head Bolt | 1 |
| 31 | 20342.00 | Right Plate | 1 |
| 32 | 20293.00 | Nut | 1 |
| 33 | 20343.00 | Magazine Cover | 1 |
| 34 | 20295.00 | Pusher Spring | 1 |
| 35 | 20296.00 | Wear Plate | 1 |
| 36 | 20297.00 | Lever Lock | 1 |

* Standard hardware item available locally
 Δ Not Shown

| Recommended Accessories | | Qty./Box | Model No. |
|-------------------------|----------------------------------|----------|-----------|
| Δ | 18 Gauge Brad Nails, 3/8" Long | 5000 | 9-18340 |
| Δ | 18 Gauge Brad Nails, 5/8" Long | 5000 | 9-18341 |
| Δ | 18 Gauge Brad Nails, 5/8" Long | 1000 | 9-19171 |
| Δ | 18 Gauge Brad Nails, 1" Long | 5000 | 9-18342 |
| Δ | 18 Gauge Brad Nails, 1" Long | 1000 | 9-19172 |
| Δ | 18 Gauge Brad Nails, 1 1/4" Long | 5000 | 9-18343 |
| Δ | 18 Gauge Brad Nails, 1 1/4" Long | 1000 | 9-19173 |

| KEY NO. | PART NO. | DESCRIPTION | QTY. |
|---------|----------|-------------------------------|------|
| 37 | 20344.00 | Magazine | 1 |
| 38 | 06086.00 | 4-0.7 x 8mm Socket Head Bolt | 3 |
| 39 | 20299.00 | Push Button | 1 |
| 40 | 17437.00 | Spring | 1 |
| 41 | 20246.00 | 3 x 23mm Spring Pin | 2 |
| 42 | 20300.00 | Trigger | 1 |
| 43 | 20301.00 | 2.5 x 24mm Spring Pin | 2 |
| 44 | 06078.00 | 4-0.7 x 12mm Socket Head Bolt | 2 |
| 45 | 20302.00 | Washer | 5 |
| 46 | 20303.00 | Rear Support | 1 |
| 47 | 20276.00 | 3 x 33mm Spring Pin | 1 |
| 48 | 06080.00 | 4-0.7mm Fiber Nut | 1 |
| 49 | N/A | Body | 1 |
| 50 | 04327.00 | 9.8 x 1.9mm O-Ring | 1 |
| 51 | 20304.00 | Air Manifold | 1 |
| 52 | 20305.00 | 29.82 x 2.62 mm O-Ring | 1 |
| 53 | 20306.00 | Trigger Spring | 1 |
| 54 | 20307.00 | Trigger Cap | 1 |
| 55 | 20308.00 | 10.82 x 1.78mm O-Ring | 1 |
| 56 | 20309.00 | Valve Stem | 1 |
| 57 | 06449.00 | 2.5 x 1.4mm O-Ring | 2 |
| 58 | 04325.00 | Trigger Valve Spring | 1 |
| 59 | 20310.00 | Trigger Valve Head | 1 |
| 60 | 20311.00 | 7.5 x 1.5mm O-Ring | 1 |
| 61 | 20312.00 | Latch | 1 |
| 62 | 20313.00 | Lever | 1 |
| 63 | 20314.00 | Latch Spring | 1 |
| 64 | 20345.00 | End Cover | 1 |
| 65 | 20502.00 | Trip Lever | 1 |
| 66 | 20547.00 | E-Ring | 1 |
| 67 | 20503.00 | Nut | 1 |
| 68 | 20548.00 | Nut Guide | 1 |
| 69 | 20549.00 | Knob | 1 |
| Δ | 20346.00 | Warning Label | 1 |
| Δ | 20347.01 | Operator's Manual | 1 |
| Δ | 9-18335 | Storage Case | 1 |

| Rebuild Kits | | | |
|--------------|----------|---|---|
| Δ | 20318.00 | Trigger Rebuild Kit Fig. 9, Nos. 53, 55, 56, 60 and two 57 | 1 |
| Δ | 20319.00 | Head Valve Rebuild Kit Fig. 9, Nos. 3, 4, 5 and 8 | 1 |
| Δ | 20348.00 | Piston-Ram Assembly Rebuild Kit Fig. 9, Nos. 10, 11, 12 and 14 | 1 |

Get it fixed, at your home or ours!

Your Home

For repair – **in your home** – of **all** major brand appliances, lawn and garden equipment, or heating and cooling systems, **no matter who made it, no matter who sold it!**

For the replacement parts, accessories and owner's manuals that you need to do-it-yourself.

For Sears professional installation of home appliances and items like garage door openers and water heaters.

1-800-4-MY-HOME® (1-800-469-4663)

Call anytime, day or night (U.S.A. and Canada)

www.sears.com www.sears.ca

Our Home

For repair of carry-in items like vacuums, lawn equipment, and electronics, call or go on-line for the location of your nearest **Sears Parts & Repair Center.**

1-800-488-1222

Call anytime, day or night (U.S.A. only)

www.sears.com

To purchase a protection agreement (U.S.A.) or maintenance agreement (Canada) on a product serviced by Sears:

1-800-827-6655 (U.S.A.)

1-800-361-6665 (Canada)

Para pedir servicio de reparación a domicilio, y para ordenar piezas:

1-888-SU-HOGARSM

(1-888-784-6427)

Au Canada pour service en français:

1-800-LE-FOYER^{MC}

(1-800-533-6937)

www.sears.ca

SEARS

® Registered Trademark / ™ Trademark / SM Service Mark of Sears, Roebuck and Co.

® Marca Registrada / ™ Marca de Fábrica / SM Marca de Servicio de Sears, Roebuck and Co.

^{MC} Marque de commerce / ^{MD} Marque déposée de Sears, Roebuck and Co.

© Sears, Roebuck and Co.

Free Manuals Download Website

<http://myh66.com>

<http://usermanuals.us>

<http://www.somanuals.com>

<http://www.4manuals.cc>

<http://www.manual-lib.com>

<http://www.404manual.com>

<http://www.luxmanual.com>

<http://aubethermostatmanual.com>

Golf course search by state

<http://golfingnear.com>

Email search by domain

<http://emailbydomain.com>

Auto manuals search

<http://auto.somanuals.com>

TV manuals search

<http://tv.somanuals.com>