

# Operator's Manual



## Variable Speed WOOD LATHE

Model No.  
351.217120

SAFETY

ASSEMBLY

OPERATION

MAINTENANCE

PARTS LIST

ESPAÑOL

### **CAUTION:**

Read and follow all Safety  
Rules and Operating  
Instructions before First  
Use of this Product.

**Sears, Roebuck and Co., Hoffman Estates, IL 60179 U.S.A.**

[www.sears.com/craftsman](http://www.sears.com/craftsman)

18184.02 Draft (11/10/02)

## TABLE OF CONTENTS

Warranty . . . . .	2
Safety Rules . . . . .	2-3
Unpacking . . . . .	3
Assembly . . . . .	4
Installation . . . . .	4-6
Operation . . . . .	6-19
Maintenance . . . . .	20
Troubleshooting . . . . .	21
Parts Illustration and List . . . . .	24-27
Español . . . . .	28-51

## WARRANTY

### FULL ONE YEAR WARRANTY ON CRAFTSMAN VARIABLE SPEED WOOD LATHE

If this product fails due to a defect in material or workmanship within one year from the date of purchase, Sears will at its option repair or replace it free of charge. Contact your nearest Sears Service Center (1-800-4-MY-HOME) to arrange for product repair, or return this product to place of purchase for replacement.

If this product is used for commercial or rental purposes, this warranty will apply for 90 days from the date of purchase.

This warranty applies only while this product is used in the United States.

This warranty gives you specific legal rights, and you may also have other rights which vary from state to state.

Sears, Roebuck and Co., Dept. 817WA, Hoffman Estates, IL 60179

## SAFETY RULES

**CAUTION:** Always follow proper operating procedures as defined in this manual — even if you are familiar with use of this or similar tools. Remember that being careless for even a fraction of a second can result in severe personal injury.

### BE PREPARED FOR JOB

- Wear proper apparel. Do not wear loose clothing, gloves, neckties, rings, bracelets or other jewelry which may get caught in moving parts of machine.
- Wear protective hair covering to contain long hair.
- Wear safety shoes with non-slip soles.
- Wear safety glasses complying with United States ANSI Z87.1. Everyday glasses have only impact resistant lenses. They are **NOT** safety glasses.
- Wear face mask or dust mask if operation is dusty.
- Be alert and think clearly. Never operate power tools when tired, intoxicated or when taking medications that cause drowsiness.

### PREPARE WORK AREA FOR JOB

- Keep work area clean. Cluttered work areas invite accidents.
- Do not use power tools in dangerous environments. Do not use power tools in damp or wet locations. Do not expose power tools to rain.
- Work area should be properly lighted.

- Keep visitors at a safe distance from work area.
- Keep children out of workplace. Make workshop child-proof. Use padlocks, master switches or remove switch keys to prevent any unintentional use of power tools.
- Keep power cords from coming in contact with sharp objects, oil, grease, and hot surfaces.

### TOOL SHOULD BE MAINTAINED

- Always unplug tool prior to inspection.
- Consult manual for specific maintaining and adjusting procedures.
- Keep tool lubricated and clean for safest operation.
- Keep all parts in working order. Check to determine that the guard or other parts will operate properly and perform their intended function.
- Check for damaged parts. Check for alignment of moving parts, binding, breakage, mounting and any other condition that may affect a tool's operation.
- A guard or other part that is damaged should be properly repaired or replaced. Do not perform makeshift repairs. (Use parts list provided to order replacement parts.)
- Never adjust attachments while running. Disconnect power to avoid accidental start-up.
- Have damaged or worn power cords replaced immediately.
- Keep cutting tools sharp for efficient and safest operation.

### KNOW HOW TO USE TOOL

- Use right tool for job. Do not force tool or attachment to do a job for which it was not designed.
- Disconnect tool when changing attachments.
- Avoid accidental start-up. Make sure that the tool is in the "off" position before plugging in, turning on safety disconnect or activating breakers.
- Do not force tool. It will work most efficiently at the rate for which it was designed.
- Keep hands away from chuck, centers and other moving parts.
- Never leave tool running unattended. Turn the power off and do not leave tool until it comes to a complete stop.
- Do not overreach. Keep proper footing and balance.
- Never stand on tool. Serious injury could occur if tool is tipped or if centers are unintentionally contacted.
- Know your tool. Learn the tool's operation, application and specific limitations.
- Handle workpiece correctly. Mount firmly in holding devices. Protect hands from possible injury.
- Turn machine off if workpiece splits or becomes loose.
- Use cutting tools as recommended in "Operation."

**WARNING:** For your own safety, do not operate your wood lathe until it is completely assembled and installed according to instructions.

### PROTECTION: EYES, HANDS, FACE, BODY, EARS

- If any part of your lathe is missing, malfunctioning, or has been damaged or broken, cease operating immediately until the particular part is properly repaired or replaced.
- Wear safety goggles that comply with United States ANSI Z87.1 and a face shield or dust mask if operation is dusty. Wear ear plugs or muffs during extended periods of operation.
- Small loose pieces of wood or other objects that contact a spinning workpiece can be propelled at very high speed. This can be avoided by keeping the lathe clean.

- Never turn the lathe ON before clearing the bed, head and tailstock of all tools, wood scraps, etc., except the workpiece and related support devices for the operation planned.
- Never place your face or body in line with the chuck or faceplate.
- Never place your fingers or hands in path of cutting tools.
- Never reach in back of the workpiece with either hand to support the piece, remove wood scraps, or for any other reason. Avoid awkward operations and hand positions where a sudden slip could cause fingers or hand to move into a spinning workpiece.
- Shut the lathe OFF and disconnect power source when removing the faceplate, changing the center, adding or removing an auxiliary device, or making adjustments.
- Turn key lock switch to "off" and remove key when tool is not in use.
- If the workpiece splits or is damaged in any way, turn lathe OFF and remove the workpiece from the holders. Discard damaged workpiece and start with a new piece of wood.
- Use extra care when turning wood with twisted grain or wood that is twisted or bowed — it may cut unevenly or wobble excessively.

### KNOW YOUR CUTTING TOOLS

- Dull, gummy, improperly sharpened or set cutting tools can cause vibration and chatter during cutting operations. Minimize potential injury by proper care of tools and regular machine maintenance.

### THINK SAFETY

Safety is a combination of operator common sense and alertness at all times when the lathe is being used.

- For your own safety, read all rules and precautions in the operator's manual before using this tool.
- For eye protection, wear safety glasses complying with United States ANSI Z87.1.
- Do not wear loose clothing, gloves, neckties, rings, bracelets or other jewelry that could get caught in moving parts of machine or workpiece. Wear protective hair covering to contain long hair.
- Tighten all clamps, fixtures and tailstock before applying power. Check to make sure that all tools and wrenches have been removed.
- With switch off, rotate workpiece by hand to make sure that there is adequate clearance. Start the machine on lowest speed setting to verify that the workpiece is secure.
- For large pieces, create a rough shape on another piece of equipment before installing on faceplate.
- Do not mount any workpieces that have splits or knots.
- Remove any center from spindle when using an outboard device for auxiliary turning.
- **Never** attempt to remount a faceplate turning to the faceplate for any reason.
- **Never** attempt to remount a between-centers turning if the original centers on the turning have been altered or removed.
- When remounting a between-centers turning that has non-altered original centers, make sure that the speed is at the lowest setting for start-up.
- Use extra caution when mounting a between-centers turning to the faceplate, or a faceplate turning to between-centers, for secondary operations. Make sure that the speed is at the lowest setting for start-up.

- **Never** perform any operation with this lathe where the workpiece is hand-held. Do not mount a reamer, milling cutter, drill bit, wire wheel or buffing wheel to the headstock spindle.
- When hand-sanding faceplate or between-centers mounted workpieces, complete all sanding **BEFORE** removing the workpiece from the lathe.
- **Never** run the spindle in the wrong direction. The cutting tool could be pulled from your hands. The workpiece should always turn towards the operator.
- For spindle turning, **ALWAYS** position the tool rest above the centerline of the workpiece and spindle (approximately  $\frac{1}{8}$ ").
- Use the drill chuck accessory in the tail stock only. Do not mount any drill bit that extends more than 6" beyond chuck jaws.

**CAUTION:** Follow safety instructions that appear on the headstock assembly for your lathe.

## UNPACKING

Refer to Figure 1.

Check for shipping damage. If damage has occurred, a claim must be filed with carrier. Check for completeness. Immediately report missing parts to dealer.

Your wood lathe is shipped complete in one carton and includes a motor. Separate all parts from packing materials and check each one with the unpacking list to make certain all items are accounted for before discarding any packing material.

If any parts are missing, do not attempt to assemble the lathe, plug in the power cord, or turn the switch on until the missing parts are obtained and properly installed.

- A Lathe
- B Leg (4)
- C Brace (2)
- D Top (2)
- E Support (2)
- F 12" Tool Rest
- G 6" Tool Rest
- H 4" Face Plate

Parts Bag (Lathe) - Not Shown

Parts Bag (Stand) - Not Shown

**IMPORTANT:** The bed is coated with a protectant. To ensure proper fit and operation, remove coating. Coating is easily removed with mild solvents, such as mineral spirits, and a soft cloth. Avoid getting cleaning solution on paint or any of the rubber or plastic parts. Solvents may deteriorate these finishes. Use soap and water on paint, plastic or rubber components. Wipe all parts thoroughly with a clean dry cloth. Apply paste wax to the bed.

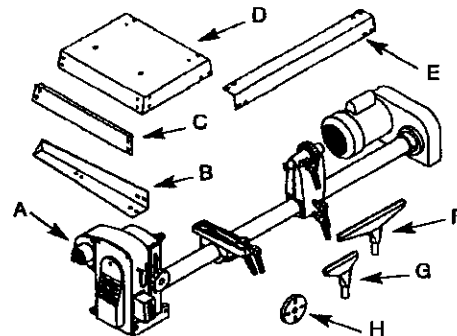

Figure 1 - Unpacking

## ASSEMBLY

Refer to Figures 2 - 3.

**CAUTION:** Do not attempt assembly if parts are missing. Use this manual to order replacement parts.

- Remove all components from the shipping carton and verify against the parts list on page 3. Clean each component and remove shipping preservatives (coatings) as required.

### ASSEMBLE STAND

**NOTE:** Hand tighten all hex nuts during stand assembly. Do not completely tighten nuts until stand assembly is complete.

- Place both top pieces upside down on floor or bench top. Attach front and rear supports to tops using the carriage bolts, flat washers, lock washers and hex nuts.
- Attach legs to inside of tops using carriage bolts, flat washers, lock washers and hex nuts.
- Attach braces to inside of legs using carriage bolts, flat washers, lock washers and hex nuts.
- Turn stand upright. Level stand and secure all nuts.

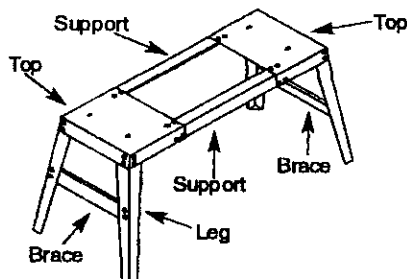

Figure 2 - Lathe Stand Assembled

### MOUNT LATHE TO STAND

**NOTE:** Lathe weighs approximately 130 lbs. Two people may be required for this operation.

- Observe location of mounting holes in the stand top. Position lathe on stand top so that the mounting holes in the stand are aligned with holes in the headstock and motor support casting. Secure lathe from underneath stand using socket head bolts and flat washers.
- Insert 6" or 12" tool rest into holder and secure in position with locking handle.
- Attach speed control knob.
- When the wood lathe is ready for use, it should appear as it does in Figure 3.

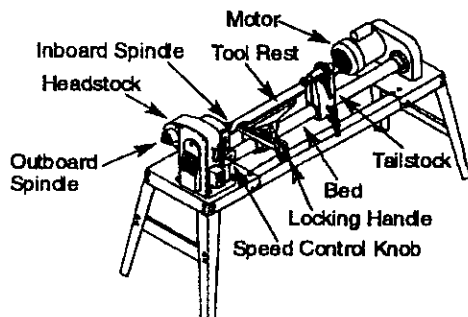

Figure 3 - Parts of the Lathe

- Examine the line cord to make sure that the plug is in good condition and that the insulation has not been damaged during transit.

## INSTALLATION

Refer to Figures 4-9.

### LOCATION OF WOOD LATHE

The lathe should be positioned so that neither the operator nor a casual observer is forced to stand in line with the spinning chuck.

### INSTALLATION OF CENTERS

The spur center and the bearing center have Morse taper #1 to match the spindle and tail stock bores. To install the centers, slide them into the bores with a firm, swift movement. They will be further secured when a workpiece is squeezed between the centers.

### REMOVAL OF SPUR CENTER FROM SPINDLE

- To remove the spur center from the spindle, insert the center removal rod into the spindle and gently tap the center out. Refer to Figure 4.

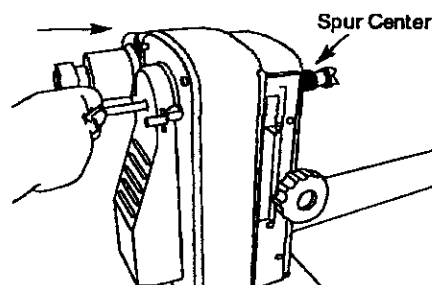

Figure 4 - Spur Center Removal

### REMOVAL OF BEARING CENTER FROM RAM

- To remove bearing center from tail stock quill, insert the center removal rod into the quill and gently tap the center out. Refer to Figure 5.

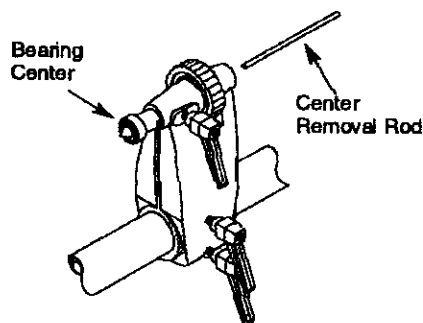

Figure 5

### POWER SOURCE

**WARNING:** Do not connect wood lathe to the power source until all assembly steps have been completed.

The motor is designed for operation on the voltage and frequency specified. Normal loads will be handled safely on voltages not more than 10% above or below specified voltage. Running the unit on voltages which are not within range may cause overheating and motor burn-out. Heavy loads require that voltage at motor terminals be no less than the voltage specified on nameplate.

- Power supply to the motor is controlled by a single pole locking rocker switch. Remove the key in the rocker switch to prevent unauthorized use.

**GROUNDING INSTRUCTIONS**

**WARNING:** Improper connection of equipment grounding conductor can result in the risk of electrical shock. Equipment should be grounded while in use to protect operator from electrical shock.

- Check with a qualified electrician if grounding instructions are not understood or if in doubt as to whether the tool is properly grounded.
- This tool is equipped with an approved 3-conductor cord rated at 300V and a 3-prong grounding type plug (see Figure 6) for your protection against shock hazards.

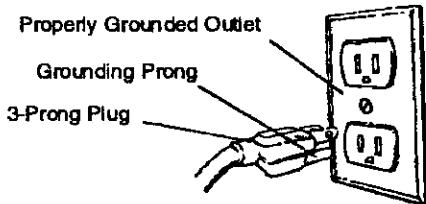

Figure 6 - 3-Prong Receptacle

- Grounding plug should be plugged directly into a properly installed and grounded 3-prong grounding-type receptacle, as shown (Figure 6).
- Do not remove or alter grounding prong in any manner. In the event of a malfunction or breakdown, grounding provides a path of least resistance for electrical shock.

**WARNING:** Do not permit fingers to touch the terminals of plug when installing or removing from outlet.

- Plug must be plugged into matching outlet that is properly installed and grounded in accordance with all local codes and ordinances. Do not modify plug provided. If it will not fit in outlet, have proper outlet installed by a qualified electrician.
- Inspect tool cords periodically and if damaged, have them repaired by an authorized service facility.
- Green (or green and yellow) conductor in cord is the grounding wire. If repair or replacement of the electric cord or plug is necessary, do not connect the green (or green and yellow) wire to a live terminal.
- Where a 2-prong wall receptacle is encountered, it must be replaced with a properly grounded 3-prong receptacle installed in accordance with National Electric Code and local codes and ordinances.

**WARNING:** This work should be performed by a qualified electrician.

A temporary 3-prong to 2-prong grounding adapter (see Figure 7) is available for connecting plugs to a two pole outlet if it is properly grounded.

- Do not use a 3-prong to 2-prong grounding adapter unless permitted by local and national codes and ordinances.
- (A 3-prong to 2-prong grounding adapter is not permitted in Canada.) Where permitted, the rigid green tab or terminal on the side of the adapter must be securely connected to a permanent electrical ground such as a properly grounded water pipe, a properly grounded outlet box or a properly grounded wire system.
- Many cover plate screws, water pipes and outlet boxes are not properly grounded. To ensure proper ground, grounding means must be tested by a qualified electrician.

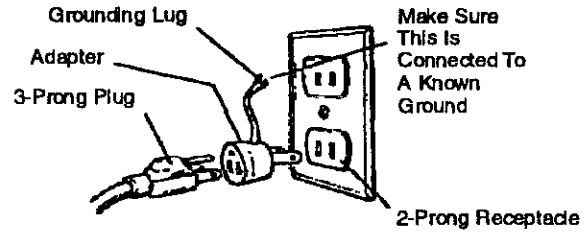

Figure 7 - 2-Prong Receptacle with Adapter

**EXTENSION CORDS**

- The use of any extension cord will cause some drop in voltage and loss of power.
- Wires of the extension cord must be of sufficient size to carry the current and maintain adequate voltage.
- Use the table to determine the minimum wire size (A.W.G.) extension cord.
- Use only 3-wire extension cords having 3-prong grounding type plugs and 3-pole receptacles which accept the tool plug.
- If the extension cord is worn, cut, or damaged in any way, replace it immediately.

**Extension Cord Length**

	Wire Size A.W.G.
Up to 25 ft. ....	.18

**NOTE:** Using extension cords over 25 ft. long is not recommended.

**MOTOR**

The wood lathe is assembled with motor and wiring installed.

Horsepower (Maximum Developed) .....	1
Voltage .....	120/240
Amperes .....	8/4
Hertz .....	60
Phase .....	Single
RPM .....	1725
Rotation (viewed from motor shaft) .....	Counterclockwise

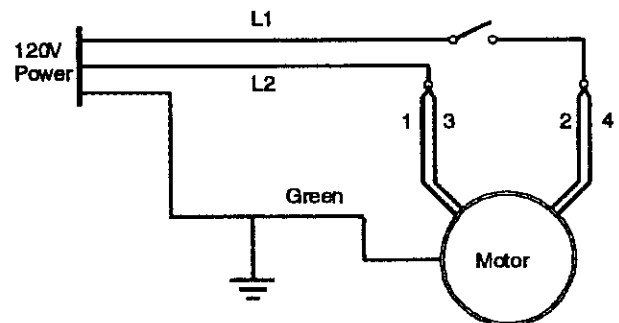

Figure 8 - Wiring Schematic

**ELECTRICAL CONNECTIONS**

**WARNING:** Make sure unit is off and disconnected from power source before inspecting any wiring.

The motor is installed and wiring connected as illustrated in the wiring schematic (see Figure 8).

The lathe is prewired for use on a 120 volt, 60-HZ power supply. The power supply to the motor is controlled by a single pole locking rocker switch.

The power lines are inserted directly onto the switch. The green ground line must remain securely fastened to the frame to properly protect against electrical shock.

- Remove the key to prevent unauthorized use.

### 240 VOLT OPERATION

- To use the lathe with a 240V, single-phase power supply, have a qualified electrician attach a 240 volt, 15A 3-prong plug onto lathe line cord and install the proper connectors and receptacles to power supply.
- See wiring diagram (Figure 9) for wiring instructions.

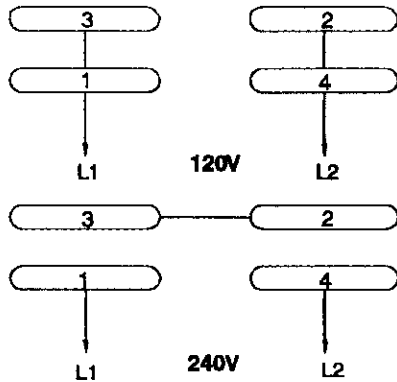

Figure 9 - Wiring Schematic

## OPERATION

Refer to Figures 10 - 74.

### DESCRIPTION

Craftsman 36" variable speed wood lathe provides capability to turn wooden workpieces up to 36" long and 4" diameter. This lathe can also turn bowls up to 12" diameter and 4" thick. The motor rotates at 1725 RPM and the spindle speeds are 380-2150 RPM. Outboard spindle allows convenient out-board turning of bowls up to 15" diameter.

### SPECIFICATIONS

Turning length (max.)	36"
Bowl diameter (max.)	12"
Overall length	60"
Overall height	13"
Width	15"
Inboard Spindle Speed	380 to 2150 RPM
Outboard Spindle Speed	190-1075 RPM
Spindle Taper	1MT
Spindle Thread	1"-8
Tail Stock Taper	1MT
Switch	SP, Locking rocker
Motor	120/240V, 8/4 AMPS
Weight	130 lbs

**WARNING:** Operation of any power tool can result in foreign objects being thrown into the eyes, which can result in severe eye damage. Always wear safety goggles complying with Unites States ANSI Z87.1 (shown on package) before commencing power tool operation. Safety goggles are available at Sears retail stores or catalog.

**CAUTION:** Always observe the following safety precautions:

### SAFETY PRECAUTIONS

- Whenever adjusting or replacing any parts on the tool, turn switch OFF and remove the plug from power source.

- Recheck all locking handles. They must be tightened securely.
- Make sure all moving parts are free and clear of any interference.
- Make sure all fasteners are tight and have not vibrated loose.
- With power disconnected, test operation by hand for clearance and adjust if necessary.
- Always wear eye protection or face shield.
- After turning switch on, always allow the spindle to come up to full speed before turning.
- Be sure motor runs counterclockwise when viewing spindle from the right end (inboard side of headstock).
- Keep hands clear of spindle, centers, faceplates and other moving parts of machine.
- For optimum performance, do not stall motor or reduce speed. Do not force the tool into the work.

### ON-OFF SWITCH

Refer to Figure 10.

Power supply to the lathe is controlled by the locking rocker switch. To turn lathe on:

- Pull rocker switch up to the ON position.

To turn lathe off:

- Switch off the rocker switch.

The rocker switch has a removable key to prevent unauthorized use or accidental start-up of the lathe. Removing the key will lock the lathe from use.

To lock the lathe:

- Switch off the rocker switch.
- Disconnect the line cord from power source.
- Pull out the removable key. The key has the words, "Remove to Lock".
- Store key in a safe place

**NOTE:** With the key removed, the rocker can be "ROCKED", but the switch cannot be actuated.

To unlock the lathe:

- Position the rocker in the OFF position.
- Insert the key into the rocker.
- Connect line cord to power source.
- The switch can now be actuated.

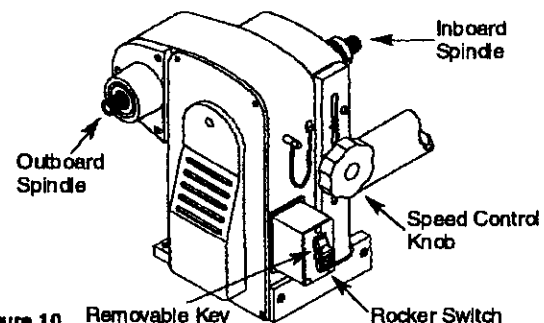

Figure 10 Removable Key

### CHANGING SPEEDS

To vary spindle speeds, rotate speed control knob to the desired setting. The speed label on the headstock shows inboard spindle speeds in black and outboard spindle speeds in red. Refer to speed chart for specific turning operations.

**CAUTION:** Change speeds only while motor is running.

## SPINDLE TURNING

If you have never done any amount of wood turning, we suggest that you practice using the various wood turning tools. Start with a small spindle turning.

Be sure to study the following pages of this manual. They explain and illustrate the correct use of the turning tools, the positioning of the tool rest, and other information to help you gain experience.

- Select a piece of wood 2" x 2" x 12".
- Draw diagonal lines on each end to locate the centers.

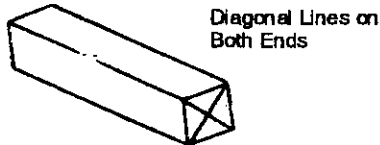

Figure 11

- On one end, make a saw cut approximately  $\frac{1}{8}$ " deep on each diagonal line. This is for the spur center.
- The other end uses the bearing center. Place the point of the bearing center on the wood where the diagonal lines cross.
- Drive the bearing center into the wood. Use a wooden mallet or a plastic hammer, but put a piece of wood on the end of the bearing center to protect it from harm.

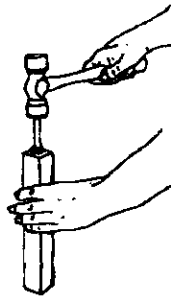

Figure 12

- Remove the bearing center and drive the spur center into the other end of the wood. Make sure the spurs are in the saw cuts. Remove the spur center.
- Make sure the centers and the hole in the spindle and the tail stock ram are clean. Insert the spur center into the headstock and the bearing center into the tail stock. Tap them in lightly with a piece of wood. Do not drive them in.
- If the tail stock center is not of the ball bearing type, put a drop of oil or wax on the wood where it contacts the center. This will lubricate the wood while it is turning.
- Place the wood between the centers and lock the tail stock.
- Move the bearing center into the wood by turning the hand wheel. Make sure that the bearing center and spur center are "seated" into the wood in the holes made earlier. Rotate the wood by hand while turning the hand wheel.
- Adjust the tool rest approximately  $\frac{1}{8}$ " away from the corners of the wood and  $\frac{1}{8}$ " above the center line. Note the angled position of the tool rest base. Lock the tool rest base and the tool rest.

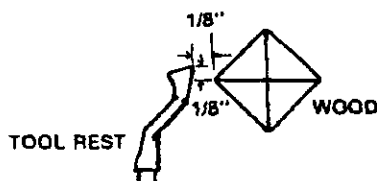

Figure 13

- Observe the speed chart (see page 14). For example, a 2" square turning up to 18" long should run at 1100 RPM for "roughing". Rotate the wood by hand to make sure that the corners do not strike the tool rest and verify that the indexing pin is not engaged.

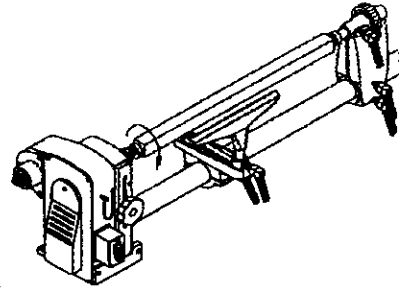

Figure 14

## INDEXING

Refer to Figure 15.

The spindle pulley has 24 equally spaced slots (15° apart). The index pin passes through the headstock, engages with one of the 24 slots and locks the spindle from turning while you put a mark on the workpiece.

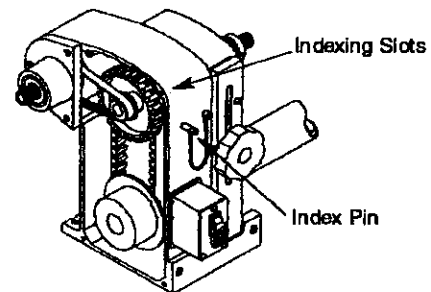

Figure 15

For example, to locate the position of six flutes on a cylinder:

- Open the rear cover.
- Push index pin until the index pin engages one of the 24 slots in the spindle pulley.
- Adjust the 12" tool rest to the centerline of the workpiece and make a mark.
- Pull index pin out to release pin. Slowly rotate the workpiece until pin is located 60° (4 holes) from initial position. Engage index pin into the pulley and place another mark on the workpiece.
- Continue these steps until there are 6 marks on the workpiece.
- Continue turnings or wheel turnings can be marked in the same manner.

**WARNING:** The indexing pin must be disengaged for all other operations on the lathe.

## OUTBOARD TURNING

This technique makes it possible to do jobs on this machine that are too large to mount conventionally. It is straight forward faceplate turning, except, because of the work size, caution must be taken and speeds must be restricted to minimums. If you anticipate doing outboard turning you must use a bowl turning rest (see Recommended Accessories, page 27). The bowl turning rest is attached to the lathe bed. See Figure 16, page 8.

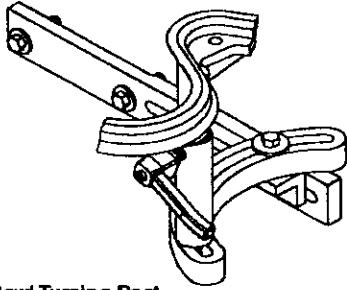

Figure 16 - Bowl Turning Rest

**CAUTION:** Do not try to push this support when cutting. Do not try to mount work so large that the motor must strain to turn it. If you wish to experiment with this technique, do so with soft woods. Let the heavier, harder wood come later.

## USING WOODWORKING CHISELS

### SELECTION OF CHISELS

Better chisels have handles approximately 10" long to provide plenty of grip and leverage. Sharp tools are essential for clean, easy work. Select tools that will take and hold keen edges.

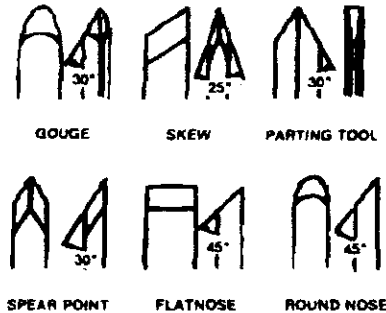

Figure 17 - The Six Commonly Used Chisel Types

### THEORY OF TURNING

The two classes of chisels are those intended primarily for cutting, and chisels used only for scraping.

- The cutting chisels are the gouge, skew and parting tool. These are the most used. They are commonly sharpened to a razor edge by honing on both sides.
- The scraping chisels are the flat nose, round nose and spear point. These are not honed on the flat sides – the wire edges produced by grinding are left on to aid in the scraping process.

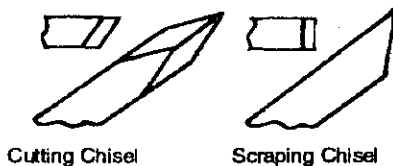

Figure 18

### Cutting and Scraping

- To cut, the chisel is held so that the sharp edge actually digs into the revolving work to peel off shavings.
- To scrape, the chisel is held at a right angle to the work surface. This tool removes fine particles instead of shavings.

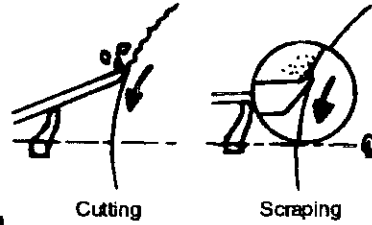

Figure 19

Many operations require that the cutting chisels be used for scraping, but scraping chisels are practically never used for cutting. Scraping dulls a chisel much faster, especially the razor sharp cutting chisels.

Cutting is faster than scraping and produces a smoother finish which requires less sanding. However, it is far more difficult to master. Scraping, on the other hand, is far more precise and easier to control.

### When You Can Cut and When You Must Scrape

There are two different approaches:

- One approach is toward a circumference of the workpiece (for example turning down the outer surface of a cylinder or the inner wall of a hollow round box). In this approach, the surface being turned travels under the chisel edge like an endless belt.
- The second approach is toward the diameter of a workpiece (as when turning the face of a faceplate turning, or the side of a large shoulder on a spindle turning). In this approach, the surface being turned rotates like a disc under the chisel edge.
- Sometimes the optimum approach will be a combination of both methods.

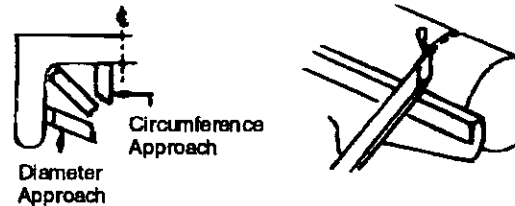

Figure 20

Either a cutting or scraping action can be used when the approach is toward a circumference – the shaving is removed like a peeling from a potato. Scraping can only be used when the approach is toward a diameter. The reason is obvious when you consider that faceplate turning practically always requires removal of wood across the grain. Wood does not peel easily across the grain and attempts to use any inappropriate cutting methods will likely result in damage to the workpiece. There is also danger that the tool could be pulled from the hands of the operator.

In general, a cutting action is used for the majority of spindle turning operations while faceplate turning is usually accomplished by the scraping method. When a combination approach is to be used, the operator will have to judge, by the feel of the work, when to stop cutting and start scraping. **Never** try to cut when it becomes difficult to hold the chisel against the roughness of the wood grain.

### How to Position Tool Rest for Circumference Cutting

When cutting, the object is to pierce the outer skin of wood to a certain desired depth and then to hold the chisel steady with the bevel edge parallel to the work circumference so that it will peel off a shaving at this desired depth.



- The only sure method of holding the chisel steady is to rest the bevel against the work (Figure 21A). When the tool rest is at the proper height, the chisel can be held with the bevel pressed against the work, and the tool rest will act as a fulcrum to support the chisel against the downward force of the revolving work.
- If the rest is placed too low, so that the chisel is held with the bevel out from the work (Figure 21B), the cutting edge will continue to dig deeper into the work. It will dig in until the "bite" becomes so deep that your hands have difficulty holding the chisel – then the improperly supported chisel will begin to bounce or chatter against the workpiece.
- If the rest is placed too low, the chisel must be held extremely high to position the bevel against the work (Figure 21C). Then the rest loses most of its value as a fulcrum and the downward force of the revolving workpiece tends to kick the chisel back out of your hands.

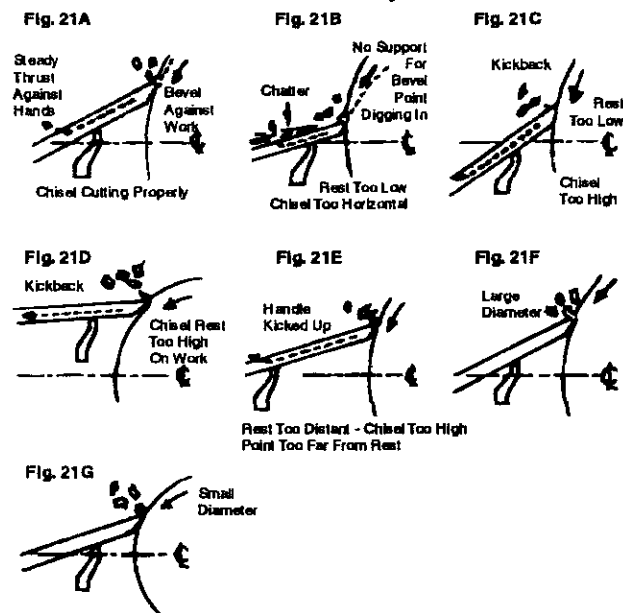

Figure 21

- If the rest is placed too high (Figure 21D) and the chisel is correctly positioned for cutting, it strikes the workpiece near the top where the direction of force exerted by the workpiece is nearly horizontal – and kickback will again result.
- If the rest is placed too far out from the work surface (Figure 21E), then, when correctly held, the chisel is again too high on the work. Also, you have less leverage on your side of the tool rest and it is even more difficult to hold the chisel. With large diameter work (Figure 21F), the tool rest can be above the workpiece centerline, and somewhat out from the work surface. With small diameter work (Figure 21G), the rest should be closer to the work surface. As work grows smaller, the rest should be repositioned.

#### How to Position Tool Rest for Circumference Scraping

In scraping operations, the tool rest position is not as critical as it is for cutting operations.

- The chisel generally is held horizontally, though it can be held at an angle to reach into tight places. Considering that the wire edge of the chisel does the scraping, Figures 22B and 22C show the results of too low or too high a position for the rest.

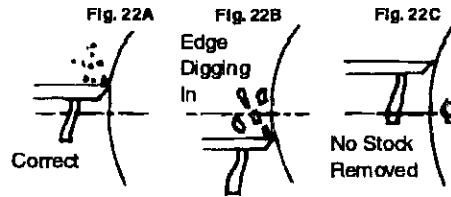

Figure 22

- Figure 22A shows the chisel action with the rest correctly positioned.

#### How to Position Chisel and Rest for Diameter Scraping

When scraping on the diameter, that portion of surface to the right of center is moving upward (Figure 23A). If a chisel is placed in this area, it will simply be carried up off the rest and out of your hands.

- All diameter approach operations must be done at the left of center.

Three different chisel contact points are shown in Figure 23B. It will be noted that when a chisel is above the workpiece center (or below it) the work surface sweeps past the chisel edge at an angle and tends to carry the chisel in one direction or the other along the rest.

- Only when the chisel contacts the work on the centerline, does the work surface pass squarely under the chisel edge. This, then, is the position in which it is easiest to hold the chisel steady. To obtain this position, place the rest approximately  $\frac{1}{4}$ " (thickness of chisel) below center.

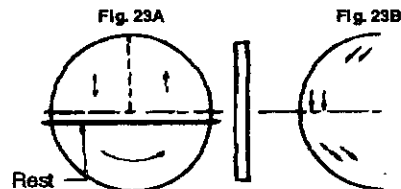

Figure 23

#### USING THE GOUGE

Three gouges, the  $\frac{1}{4}$ ",  $\frac{1}{2}$ " and  $\frac{3}{4}$ " sizes, are adequate for general homeshop turning. Other sizes from  $\frac{1}{8}$ " to 2" can be purchased to provide more flexibility.

The chief use of the gouge is for rough circumference cutting of raw stock down to a cylinder of working size. It is best to use this tool for rapid cutting away of large areas of the workpiece. When the tool is used this way, it does not produce a smooth surface. With practice, the gouge can be used for cutting coves and the shaping of long cuts.

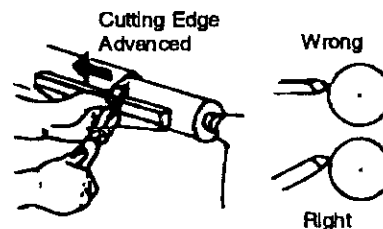

Figure 24

- When used for cutting, the gouge is always held with the convex side down. It should be rolled approximately  $30^\circ$  to  $45^\circ$  in the direction in which it is being advanced along the rest and the cutting edge should be slightly ahead of the handle.

### USING THE SKEW

- Two skews, the 1/2" and 1" sizes, are all that are needed for general use. Other sizes are available.

This tool is nearly always used to make finished cuts, to cut vees and beads, and to square shoulders. Properly used, it produces the best finish that can be obtained with a chisel. It is not recommended for scraping because the edge tends to dull more quickly.

- For finish cutting, the skew is held with the cutting edge considerably in advance of the handle, bevel side down. Keep the base of the bevel against the work. It is good practice to place the skew well over the work, pull it back until the edge begins to cut, then swing the handle into position to advance the cut.

Both the toe and the heel of the skew can be used for taking light cuts, but do not penetrate the wood too deeply without cutting clearances. There is danger of burning the tip of the tool.

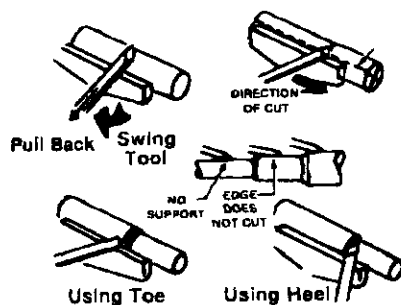

Figure 25

### USING THE PARTING TOOL

The parting tool has just one primary purpose: to cut into the workpiece as deeply as desired, or all the way through to make a cut-off. It is, therefore, a very narrow tool (1/4" wide) and shaped to cut its own clearance so that the edge will not be burned. When used for scraping, however, the parting tool should be backed off regularly to prevent overheating.

Unlike the gouge and skew, the parting tool is seldom held with the bevel against the work. Since the amount of stock removal is small, a support for the bevel is not necessary.

The tool is simply fed into the work at an angle (for cutting), or pointed at the workpiece center (for scraping). It can be held easily in one hand.

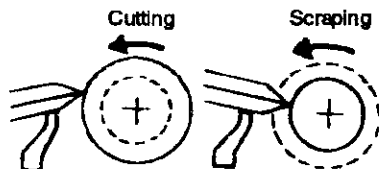

Figure 26

### USING THE SCRAPING CHISELS

- A 1/2" wide spear point chisel, a 1/2" wide round nose chisel, and a 1" wide flat nose chisel complete the list of tools ordinarily used by craftsmen and hobbyists.

Each of these scraping chisels can be purchased in various other sizes for special purposes. All are very useful for diameter scraping operations and for circumference scraping when cutting methods cannot be employed.

- The spear point is used for fine scraping and delicate operations such as the forming of beads, parallel grooves and shallow vees.
- Edges and bowl contours can be rounded with the round nose chisel.

- Any flat surface can be scraped with the flat nose chisel.

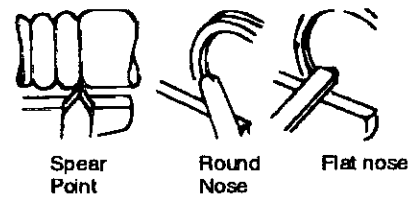

Figure 27

### USING SHAPER OR MOULDING KNIVES

- An old chisel can be made to serve as a holder for shaper or moulding knives.

Such knives make it possible to scrape many interesting shapes into the workpiece surface using one or two operations instead of the many operations required with standard chisels. It is generally not practical to use cutting methods with special shape tools. Scraping methods should be used instead.

- The holder should provide a shoulder against which the butt end of the knife can be firmly seated. The knife must be securely mounted, either by means of a screw threaded into the holder, or by compressing it between two prongs bolted together.

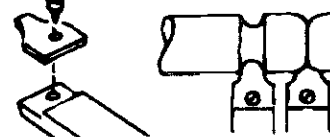

Figure 28

### USING A BLOCK PLANE

Clear, glass-smooth finishes (especially on softwoods) can be obtained by using a block plane set to take a fine shaving.

- The tool rest should be raised up approximately to the top of the workpiece – and the plane should be horizontal, but turned slightly in the direction of travel so that it will take a shearing cut.
- Two tool rests, one in front and the other behind the work, can be used to advantage in positioning the plane so as to exactly limit the depth of cut (and finished size of the workpiece).

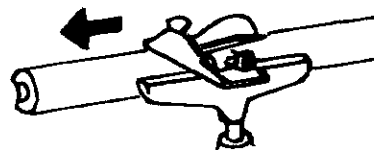

Figure 29

### USING WOOD RASPS AND FILES

- A wood rasp will remove stock quickly when held against the revolving workpiece. Care should be taken to support the rasp firmly against the tool rest. An improperly held rasp, when used on a rough surface, can kick back and cause operator injury.
- The rasp will leave a very rough finish.
- Finer finishes (similar to those produced by scraping) can be obtained by using files in the same manner. Various types of files can be used for shaping vees, beads, coves, etc. If pressed too hard into the wood, some files can burn the workpiece.
- Keep the file clean to keep it cutting uniformly. Files work best on hardwoods.

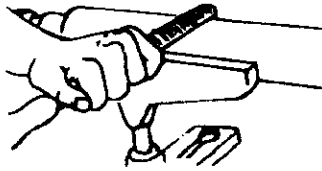

Figure 30 - Using a Rasp

#### HAND POSITIONS

When using any of the chisels, the hand takes a natural position on the tool handle. This position may be near the middle of the handle or towards the end, depending upon the amount of leverage required. The position of the hand near the tool rest is a matter of individual preference, but there are three generally accepted positions, each best for certain types of operations.

#### Roughing Off

Roughing off and other heavy work requires a firm grip and solid positioning of the chisel against the rest. This is best obtained by the tool-rest hand positioned illustrated. The wrist is dropped down so that the heel of the hand below the little finger acts as a sliding guide against the rest. The handle hand controls chisel position.

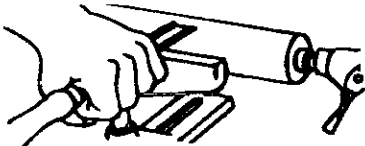

Figure 31 - Roughing

#### Finish Cutting

Finish cutting requires more control – with less force. Finish cutting is better done with the palm of the tool rest hand turned up. The wrist is still held down, and the side of the index finger acts as a guide along the rest. In this position, control of the chisel is shared by both hands. The fingers of the tool-rest hand are free to assist in positioning the tool.

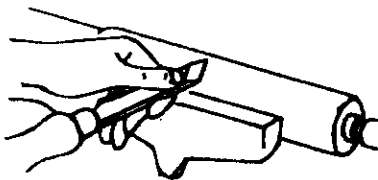

Figure 32 - Finish Cutting

#### Intricate Cutting

Intricate, delicate cutting requires extreme control with practically no force. This is best accomplished by guiding the chisel with the fingers of the tool-rest hand. The hand is held palm up with the wrist high. The little finger is placed against the rest to steady the hand. The chisel does not touch the rest and the handle hand is completely secondary to the tool-rest hand.

**NOTE:** The first and second positions are equally good for scraping operations, but the third position is practically never used for scraping.

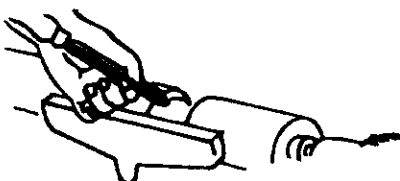

Figure 33

#### Cutting to Depth

Many scraping operations and cutting to depth with the parting tool can be easily accomplished with the one hand. The chisel is grasped firmly with the index finger on top to press it down against the rest. It is thrust straight into the work. Holding the tool in this manner leaves the other hand free to hold a pattern or calipers, etc., to check work in progress.

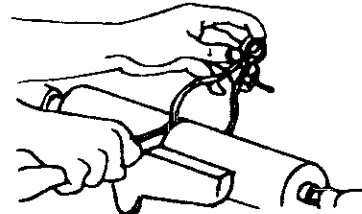

Figure 34

#### MAKING STANDARD CUTS

##### THE ROUGHING-OFF CUT

Reducing a square or odd shaped workpiece down to a cylinder of approximate size for finish turning is called "roughing-off". Faceplate turnings and large diameter spindles should first be partly reduced by sawing, but small spindles are easily turned down entirely with the large (1/4") gouge.

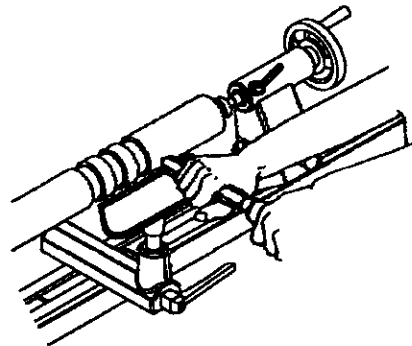

Figure 35

- Start the first cut about 2" from tail stock end – then run it toward the tailstock and off the end of the workpiece.
- Next, start another cut 2" nearer the headstock – and run it back towards the tailstock, to merge with the first cut.
- Continue cutting in this manner until 2 to 4" from the headstock is left uncut. Reverse the direction of tool travel and work one or two cuts in succession toward the headstock and off this end of the workpiece.
- Never start a cut directly at the end – if the chisel catches the end, it will damage the workpiece.
- Never take long cuts while corners remain on the work, as this tends to tear long slivers from the corners.
- The first series of cuts should not be too deep. It is better to partially reduce the work to a cylinder all along its length. After that, start a second series of cuts to complete reducing it to a cylinder.
- Once a cylinder has been formed, step lathe up to next faster speed. Further reductions in size can now be accomplished by cutting as deeply as desired at any spot along the work. At this stage, long cuts can be made from the center to either end.
- Generally, roughing off is continued until the cylinder is approximately 1/8" larger than the desired finished size.

- Roundness can be tested by laying the gouge on top of the work – it will not ride up and down when cylinder is perfectly round.

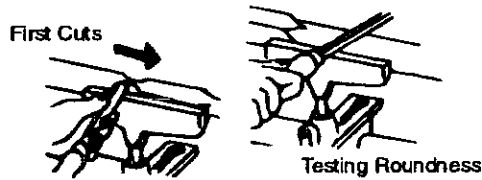

Figure 36

### ROUGH-CUTTING TO SIZE

The roughing-off cut can be made to accurately size the cylinder to a given diameter.

Another method is to make a number of sizing cuts at intervals along the work, then use the gouge to reduce the whole cylinder down to the diameter indicated by these cuts.

### MAKING SIZING CUTS

Sizing cuts are useful to establish approximate finished size diameters at various points along a workpiece. The work can then be turned down to the diameters indicated and be ready for finishing.

- Diameters for sizing cuts should be planned to be about  $\frac{1}{4}$ " greater than the desired finish diameters. A sizing cut is made with the parting tool.
- Hold the tool in one hand, and use the other hand to hold an outside caliper preset to the desired sizing-cut diameter.
- As the cut nears completion, lower the chisel point more and more into a scraping position.
- When the calipers slip over the workpiece at the bottom of the groove, then the cut is finished.

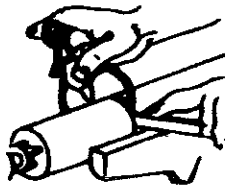

Figure 37

### SMOOTHING A CYLINDER

The final  $\frac{1}{4}$ " can be removed in two ways. Either use the 1" skew, working from the center toward both ends and taking lighter and lighter cuts until finished, or use a block plane as illustrated in Figure 29.

### CUTTING A SHOULDER

A shoulder can be the side of a square portion left in the workpiece, the side of a turned section, or the end of the workpiece. Most shoulders are perpendicular to the work axis, but a shoulder can be at any angle.

- First, mark position of the shoulder with a pencil held to the revolving workpiece.
- Second, make a sizing cut with the parting tool, placing this cut about  $\frac{1}{16}$ " outside the shoulder position and cutting to within about  $\frac{1}{16}$ " of the depth desired for the area outside of the shoulder.
- If shoulder is shallow, the toe of the skew can be used to make the sizing cut. Do not go in deeper than  $\frac{1}{8}$ " with the skew unless wider and wider vees are cut to provide clearance for this tool.

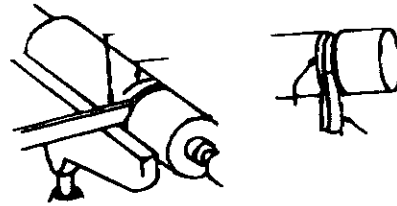

Figure 38

- Use the gouge to remove any waste stock outside of shoulder. Smooth this section, up to within  $\frac{1}{8}$ " of shoulder, in the usual manner. Finishing of the shoulder, unless it is more than 1" high, is best done with the  $\frac{1}{2}$ " skew.
- The toe of the skew is used to remove the shavings from the side of the shoulder – down to finished size.
- Hold skew so the bottom edge of bevel next to the shoulder will be very nearly parallel to side of shoulder – but with cutting edge turned away at the top so that only the extreme toe will do the cutting. If cutting edge is flat against shoulder, the chisel will run.
- Start with handle low, and raise handle to advance toe into the work.
- Cut down to finished diameter of outside area. Then, clean out the corner by advancing heel of the skew into it along the surface of the outside area.
- Tilt the cutting edge, with handle raised up so that only the extreme heel does this cutting.
- If shoulder is at end of work, the process is called squaring the end. In this case, reduce outer portion to a diameter about  $\frac{1}{4}$ " larger than tool center diameter. Then, later, saw off the waste stock.

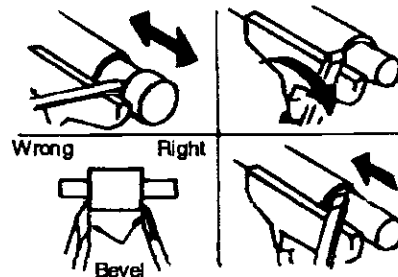

Figure 39

### CUTTING VEES

Vee grooves can be cut with either the toe or heel of the skew.

- When the toe is used, the cutting action is exactly the same as when trimming a shoulder except that the skew is tilted to cut at the required bevel. Light cuts should be taken on first one side and then the other, gradually enlarging the vee to the required depth and width.
- When the heel is used, the skew is rotated down into the work, using the rest as a pivot. Otherwise, cutting position and sequence of cuts are the same. As when using the toe, it is important that cutting be done only by extreme end of cutting edge.
- If deep vees are planned, it is quicker to start them by making a sizing cut at the center of each vee.
- Vees can also be scraped with the spear point chisel or a three-sided file.



Figure 40

### CUTTING BEADS

This operation requires considerable practice.

- First, make a pencil line to locate the tops (highest points) of two or more adjoining beads.
- Then, make a vee groove at the exact center between two lines and down to the desired depth of the separation between the beads. Be careful not to make the groove too wide or you will remove portions of the desired beads. The sides of the two adjoining beads are now cut with the heel of the skew. Use a 1/2" skew, unless beads are very large.
- Place skew at right angles with the work axis, flat against the surface, and well up near the top. The extreme heel should be just inside the pencil line that marks the top of the bead.
- Now, draw skew straight back while raising handle slowly – until edge of the heel at the pencil line starts to cut.
- As edge begins to cut, roll skew in the direction of the vee so that the exact portion of the edge which started cutting will travel in a 90° arc down to bottom of the vee.
- Upon reaching bottom of the vee, the skew should be on edge.
- Reverse the movements to cut side of the adjacent bead.



Figure 41 - Cutting Beads

It is important that only the extreme heel should do the cutting. This means that the bottom edge of the bevel next to the vee must at all times be tangent to the arc of the bead being formed.

Easier beads can be shaped with the spear point chisel.

- Use pencil marks and sizing cuts as before.
- Push the chisel straight into each cut and rotate horizontally to round off the adjacent edges. It must be moved slightly in the direction of rotation at the same time to keep the point from digging into the adjacent bead.

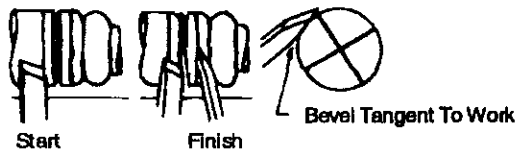

Figure 42

### CUTTING COVES (CONCAVES)

This is the most difficult single cut to master – but one of the most important in good wood turning.

- First, use pencil marks to indicate the edges.
- Then, rough out the cove, to within about 1/4" of the desired finished surface, by scraping with the gouge or round nose chisel. If the cove is to be very wide, sizing cuts can be made to plot the roughing out. Once it is roughed out, the cove can be finished in two cuts, one from each side to the bottom center.

- At the start of either cut, gouge is held with handle high and the two sides of blade held between the thumb and forefinger of tool rest hand, just behind the bevel.
- Position the fingers so that they are ready to roll the blade into cove.
- Hold blades so that bevel is at 90° angle to the work axis with point touching the pencil line and pointed into work axis.
- From this start, depress point slightly to start cut, then continue to move point down in an arc toward the bottom center cove – at the same time rolling chisel uniformly so that, at the end of the cut, it will be flat at the bottom of the cove. The object is to keep the extreme point of gouge doing the cutting from start to finish. Reverse these movements to cut the opposite side.

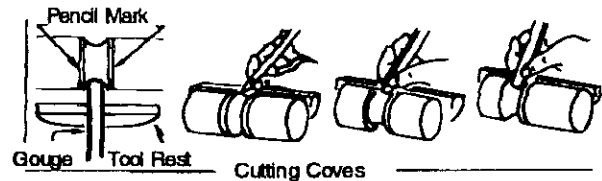

Figure 43

Coves also can be scraped to finish using the round nose chisel or a rattail file. These methods do not generally produce perfectly curved coves.

### MAKING LONG CONVEX CUTS

- First, turn work down to approximate size, using sizing cuts (as required) to determine various diameters. Finish cuts can then be made with either skew or gouge.
- If the skew is used, the principles of the operation are the same as those employed in cutting a bead – except that the curve is longer and may be irregular. Use the extreme heel throughout – start at longer end of curve (if curve is irregular) and progress toward steeper end.
- If gouge is used, make cut in the same direction. Start with the handle well back of point – swinging handle in the direction of tool travel to overtake the point, if necessary, when the steep part of the curve is reached. Object is to have the extreme point doing the cutting throughout with the bevel as tangent to curve as possible.

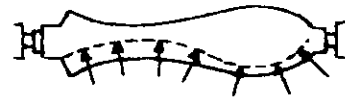

Figure 44 - Chisel Inclined in Direction of Cut

### MAKING LONG TAPER CUTS

Long taper cuts are made like long convex cuts, with the skew or gouge. However, the angle between the cutting edge and handle is kept constant during the entire cut. The handle is not swung around.

- Always cut downhill. Do not cut too deeply at the center of the taper.

### SPINDLE TURNINGS

#### PLOTTING THE SHAPE

Once the basic cuts have been mastered, you are ready to turn out finished work.

- The first step is to prepare a plan for the proposed turning. This can be laid out on a suitable sheet of paper. The layout should be to full size.

- Next, prepare the turning stock by squaring it up to the size of the largest square or round section in your plan. The stock can be cut to the exact length of the proposed turning. However, in most cases, it is best to leave the stock a little long at one or both ends to allow for trimming.
- Mount the stock in the lathe and rough it off to a maximum-size cylinder.
- Now, project your plan onto the turning by pencil marking the various critical dimensions along the length of the spindle. These dimensions can be laid out with an ordinary ruler or by using a template. Make the pencil marks about  $\frac{1}{2}$ " long so they will be visible when the work is revolved under power. The lines can be quickly traced around the spindle by touching each line with the pencil.

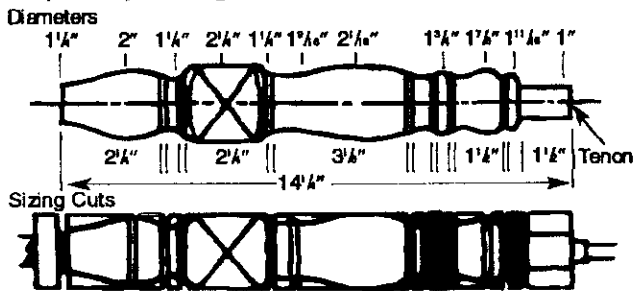

Figure 45

- After marking, use the parting tool to make sizing cuts at all of the important shoulders. When learning, you will find it best to make sizing cuts to accurately plot the various diameters. Experienced wood workers can manage with fewer such cuts at the important shoulders.
- Plan each sizing cut so that it is in waste stock and make each cut deep enough so that there will be just enough wood left under the cut for the finishing process.
- Once the sizing cuts have been completed, rough-out the excess wood with a gouge. Then, proceed with the finishing process by making the various types of cuts required.

### RECOMMENDED SPEED

Always follow recommended speed to do spindle turning depending upon the size and length of workpiece.

SQUARE	LENGTH	ROUGH RPM	FINISH RPM
1 to 2"	1 to 12"	1300	2000
1 to 2"	to 24"	1100	2000
1 to 2"	to 38"	1000	2000
2 to 4"	1 to 12"	1000	1800
2 to 4"	to 24"	900	1600
2 to 4"	to 38"	700	1400
4" Plus	1 to 12"	800	1400
4" Plus	to 24"	600	1100
4" Plus	to 38"	400	800

### DUPLICATE TURNINGS

Identical turnings require great accuracy when plotting the work and performing the various cuts. Many methods have been devised to aid in perfecting the work.

#### Use of Patterns

Professional workers generally use a pattern or layout board. This is a thin piece of wood or cardboard upon which is drawn a full-size half section of the turning. The contour of the finished surface is drawn first. Then, the diameters at various critical points are drawn to scale as vertical lines intersecting the contour line.

- By placing the pattern against the roughed-out cylinder, you can quickly mark the various points of the critical diameters.
- To make each sizing cut, use outside calipers and set these by actually measuring the length of the vertical lines on the pattern which represent the diameters desired. Make the sizing cut down to the proper diameter by using the calipers to determine when the cut is finished.
- After making the sizing cuts, hang the pattern behind the lathe where it will serve as a guide for completion of the workpiece.

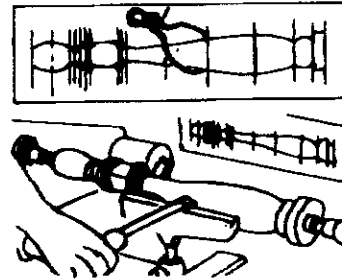

Figure 46

### Using a Template and a Diameter Board

When many identical turnings are to be produced, it is convenient to have a prepared template. This can be made of thin wood or cardboard. It is cut on a band saw or scroll saw to have the exact contour or the finished turning. The number one finished turning can also be used as a template. Attach the template to a board and then mount the board behind the lathe, on hinges, so that the template can be moved down to touch the workpiece and allow you to closely observe progress of your work.

If a great many turnings are being produced, a diameter board will save the time used for resetting calipers. This is simply a thin board along the edge of which a number of semicircular cuts have been prepared to represent all the various caliper settings required for measuring the sizing cuts. Each semi-circular cut is held against the workpiece instead of using the calipers.

Using a Template



Using a Diameter Board

Figure 47

### LONG SPINDLES

A long turning can be worked in short sections, with joints arranged to be at shoulders where they will not be noticed.

- Long thin work that is likely to whip while turning should be supported at one or two places by a backstick. This is easy to make. A simple backstick consists of a short length of wood mounted vertically in an extra tool rest and notched so that it can be used to support the spindle from behind. An improved type, which uses 2 roller skate wheels to form the notch, also is shown.
- Position the backstick against a pre-turned portion near the center of the spindle, this portion being at least  $\frac{1}{4}$ " over finish size to allow for later removal of any marks made upon it.
- Operate lathe at a slower speed than normal. Lubricate the workpiece at point of contact with the backstick. Use beeswax (preferred), lard or grease.

- After completing the turning, remove the backstick and finish off the original point of contact. Sand off any slight burns remaining on workpiece.

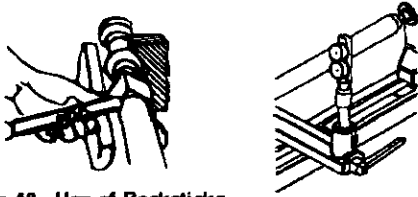

Figure 48 - Use of Backsticks

### CUTTING DOWELS

Dowels of any size can be turned quickly with the simple jig shown. If the stock is prepared as a split or quartered turning, half round and quarter rounds will be produced.

The jig uses a  $\frac{1}{2}$ " gouge as the cutting tool and will produce dowels up to  $\frac{7}{16}$ " diameter. Make the jig from suitable hardwood stock as shown.

- The hole through the jig must be large enough at the side to the left of the gouge to allow passage of the square stock. At the right of the gouge, this hole must be just the diameter of the finished dowel. Make the jig so that you can hold and guide it by hand.
- To start, center the stock like a spindle turning and turn down about 2" at the right end to desired size.
- Then, remove the stock. Place your jig over the turned end, with turned portion through the smaller jig hole, and recenter the stock on the lathe.
- Hold the jig firmly and start the lathe.
- Push the jig slowly right to left along the stock until the whole dowel is completed.

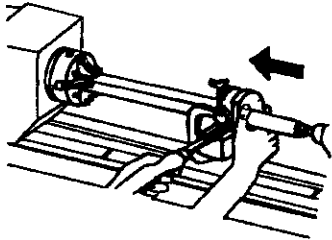

Figure 49

### MISCELLANEOUS OPERATIONS

#### GUIDE BLOCKS FOR SCRAPING OPERATIONS

A guide block can be clamped to a chisel to limit the depth of cut and aid in the production of perfect cylinders, tapers and facings on faceplate turnings. Scraping methods must be used when the guide block is employed.

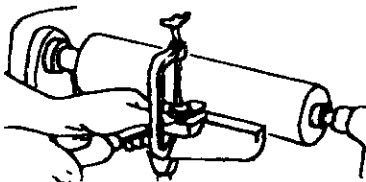

Figure 50

#### DRILLING

There are several methods of using the lathe for drilling center holes through wood stock. When the drill is properly mounted, centering of the hole is automatic.

- One method is to mount a drill in the tail stock. The workpiece is held and revolved by the headstock. If the drill has

a Morse taper shank, it can be mounted directly in some tail stock rams. Otherwise, it can be mounted in a chuck fitted with the proper type shank.

- Another method of holding the drill is to mount it in the headstock using a 4-jaw (metal-lathe) chuck or a Jacobs chuck. When this method is employed, there is no accurate support for the workpiece so that center drilling is difficult. However, cross drilling, or drilling random holes through stock can be accomplished quickly in this manner.

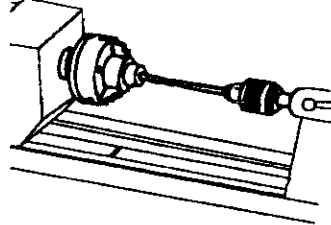

Figure 51

- For cross drilling flat sided work, use a (metal-lathe) drill pad in the tail stock and place a scrap board between the pad and the work. For cross drilling round stock, use a (metal-lathe) crotch center in the tail stock. Large workpieces can be located on supporting blocks laid upon the lathe bed. They can be held by hand or can be supported from behind by a drill pad mounted in the tail stock.

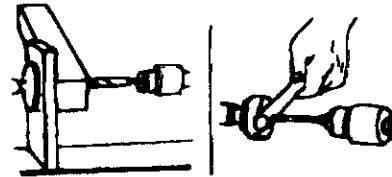

Figure 52 - Cross Drilling

### FACEPLATE AND CHUCK TURNINGS

#### PLANNING THE WORK

Make a layout first, to provide a visual pattern to follow while working the turning. Pattern can be laid out in the same manner as spindle patterns – or templates can be made which can be held against the work for visual comparison. Circles to locate the various critical points (at which the contours of the faceplate take distinct form) can be quickly scribed on the rotating work by using the dividers.

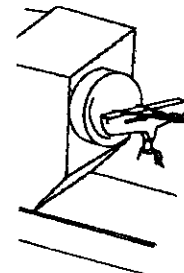

Figure 53

#### PLANNING VARIOUS CUTS

The circumference of a faceplate turning is roughed-out and finished in the same manner that a spindle is worked. Practically all of the balance of the operations, however, are done by using scraping methods. A few of the standard contours which must often be turned are illustrated in the accompanying sketch which also shows the proper chisels for shaping these contours. Any roughing out to depth is generally accomplished with the gouge held in the scraping position. See Figure 54, page 16.

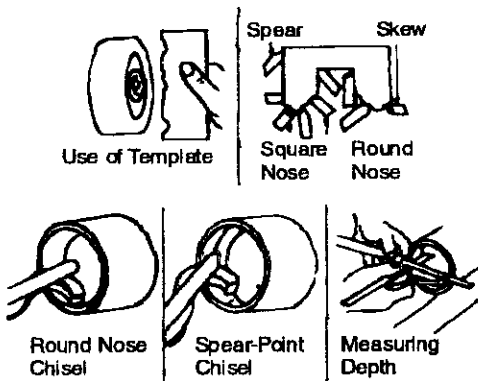

Figure 54

**RECOMMENDED SPEED**

Always follow recommended speed to do faceplate and chuck turning depending upon the size and thickness of workpiece.

SQUARE	THICKNESS	ROUGH RPM	FINISH RPM
4 to 7"	Up to 2"	1300	2000
4 to 7"	2 to 4"	1200	2000
4 to 7"	4" Plus	1000	2000
8 to 11"	Up to 2"	1000	1800
8 to 11"	2 to 4"	900	1700
8 to 11"	4" Plus	700	1400
12 to 15"	Up to 2"	700	1200
12 to 15"	2 to 4"	550	1000
12 to 15"	4" Plus	400	800

**DEEP RECESSES**

- The first step is to remove as much wood as possible by boring into the center with the largest wood bit available. This can be accomplished as illustrated in Figure 59. Be careful to measure in advance the depth to which drill can be allowed to go.

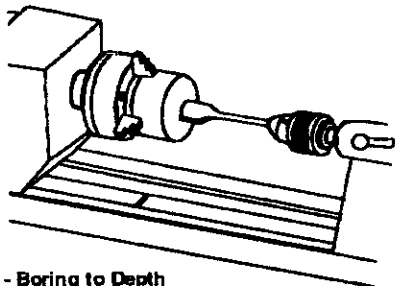

Figure 55 - Boring to Depth

- Now, remove the bulk of the waste (to rough-out the desired recess) by scraping with the round-nose chisel or the gouge. Remove up to within 1/4" of finished size in this manner. Finish off the inside circumference by scraping with the spearpoint chisel or skew. Smooth the bottom of the recess by scraping it flat with the flat nose chisel.
- Proper support must be provided at all times for the scraping chisels. Several tool rest positions are shown in the accompanying illustrations. Always endeavor to position the part of the rest that supports the tool as close to the working surface as possible. The depth and squareness of the sides of the recess can be quickly checked by holding one of the straight sided chisels and a combination square as shown.

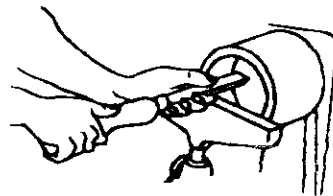

Figure 56

**FANCY FACEPLATE TURNINGS**

**PREPARING A PLUG CHUCK**

A plug chuck is an auxiliary wood chuck mounted onto a faceplate. The chuck can be any size diameter, but it should be about 1 1/2" thick for stability. The wood chuck should be provided with a 3/4" or 1" hole in the center for receiving a tenon turned at the end of the workpiece.

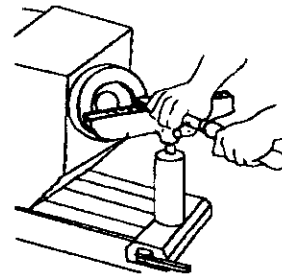

Figure 57

Once made, such chucks are permanent useful fixtures for turning balls, goblets, etc. In use, the wood stock for turning is turned between centers to produce a tenon at one end which will be a driving fit in the hole of the chuck. When mounted in the chuck, the workpiece is substantially supported for any faceplate type of turning.

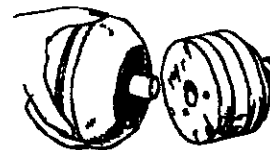

Figure 58

**TURNING CYLINDERS**

Stock for cylinders should be mounted on the screw center or a small faceplate. The tail stock can be brought up to support the work while the circumference is being turned and finished. Afterwards, the tail stock is backed off and the outer end of the cylinder is recessed, using methods already described for making deep recesses.

- After making a recess at least 1/2 of the way through the workpiece, and finishing this on the inside, remove the workpiece from the lathe.
- Now mount a short length of softwood stock on the screw center and turn this down to form a dowel that will be a tight press (not driving) fit inside the recessed end of the cylinder.
- Mount the cylinder on this wooden chuck, and recess the unworked end deep enough to form a perfect hole through the entire cylinder.

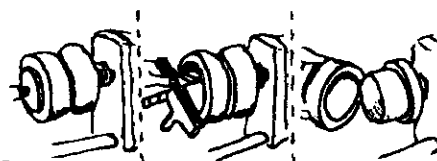

Figure 59



## RECHUCKING

Rechucking is the general term used to describe any additional work mounting that is necessary to complete a turning project. The method of working cylinders, and the use of a plug chuck as already described are typical examples. Another good example is the rechucking of a bowl.

- The work is mounted on a wood backing block secured to the large faceplate and it is turned in the usual manner. All surfaces are cut except the back side (which is against the mounting block). The work is then removed from the mounting block.
- An auxiliary chuck of softwood is now made in the same manner that the cylinder chuck is made. This chuck must have a turned recess properly sized to accommodate the rim of the bowl in a tight press fit.
- When the bowl is mounted in this chuck, the bottom can be cleaned off and slightly recessed to complete the desired contours.



Figure 60

## TURNING A RING

One method of turning a ring requires a spindle chuck.

- The work stock is first mounted to a backing block held by the large faceplate and is turned to shape on the outer side. The inside diameter of the ring is also shaped – all the way through to the backing block.
- The work is then removed from the backing block.
- A spindle chuck is now prepared so that it will be a tight press to fit inside the ring. The ring is reversed and mounted on this chuck. With the ring mounted, the remaining contours can be turned to shape.

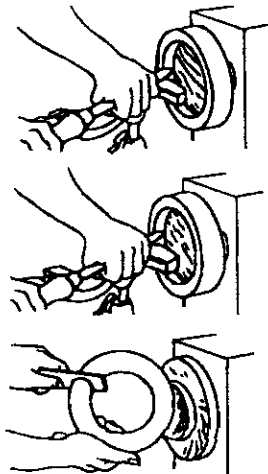

Figure 61

Another method of turning a ring makes use of a recessed chuck.

- The work stock is mounted on a screw center and one half of the ring is formed, but the ring is not cut away from its center.
- The stock is then removed, and a recessed chuck – mounted on the large faceplate – is prepared to receive the ring in a tight press fit.

- After being chucked, the remaining face of the ring can be turned to the proper contour, thus cutting away the center portion.
- In work of this type, take constant measurements or, better yet, use a template to guard against over or under cutting.

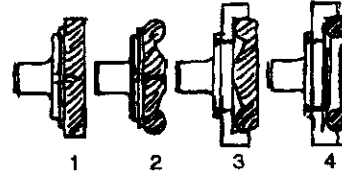

Figure 62

## TURNING BALLS

- Wooden balls of large size are first roughly turned between centers, using standard procedures.
- Smaller balls can be mounted as faceplates on the small faceplate or screw center.
- Lines drawn to indicate the center and ends of the ball shape are helpful in plotting the curve.
- A template should always be used for accurate visual observation of the work progress.

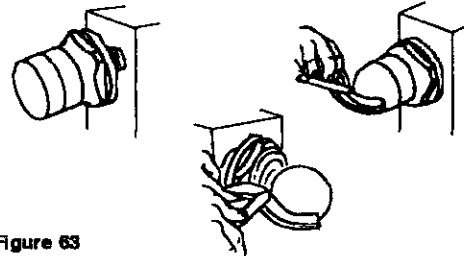

Figure 63

If the ball is mounted as a faceplate turning, almost the entire surface can be turned before it becomes necessary to rechuck it.

- Rechucking can be accomplished in a deep cup chuck which will hold the finished portion of the ball in a tight press fit.

Another method of rechucking is to use a shallow cup chuck which will not support the ball alone, but must be used in conjunction with the tail stock.

- When using the shallow chuck, a wood block is fitted to the tail stock so that the ball can revolve upon it. This block should be lubricated with beeswax or grease.
- In using the shallow chuck method, the ball is constantly shifted – never more than  $\frac{1}{4}$  turn – and always in a definite pattern.

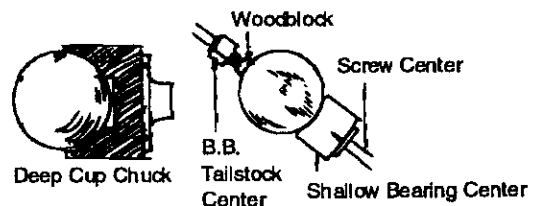

Figure 64

- Since turning between centers makes the work a perfect sphere across the grain, the ball must be mounted in the chuck so that the first scraping cuts will round it up in the opposite direction.

## TURNED BOXES

Turned boxes involve deep recessing together with a special system of working the lid and body of the box together as one unit.

- The inside of the lid is turned first.

- Next, the inside of the body is turned. A careful check must be made when turning the lip of the body portion so that the lid will be a tight press fit.
- The lid is then pressed onto the body and the outer circumference and face of the lid, together with the outer circumference of the body, are turned all at one time. This insures accurate matching of the two pieces.
- After the work is complete, the tight fit of the lid can be relieved by sanding the lip of the body.

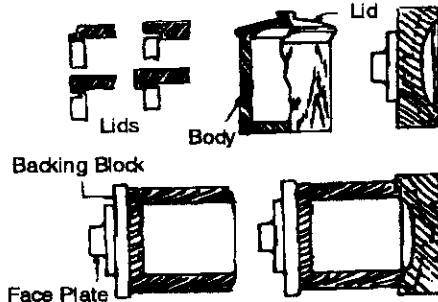

Figure 65

### SEGMENTED TURNINGS

Segmented bowls and boxes are exceptionally attractive – and this method of preparing wood stock is more economical than the use of a large piece of stock. For some types of work, segmenting is the only practical method because a block (if obtainable) would be so large that it would be very likely to warp.

- The bowl illustrated in Figure 66 requires 12 segment pieces for the sides. Bowls can also be worked with 6 or 8 pieces.
- To make the 12-piece bowl, a board about  $\frac{1}{4}$  x 3 x 30" is cut into pieces about  $2\frac{1}{2}$ " long, the saw blade being tilted  $15^\circ$  and the board being turned alternately face up and face down to make the successive cuts.
- These 12 pieces are glued together and clamped by wrapping the assembly with wire (or equivalent).
- When dry, the rim thus formed is glued to a temporary circular backing which is mounted on a large faceplate.

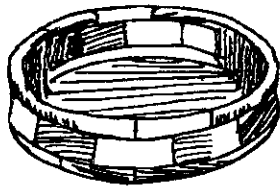

Figure 66

- A  $\frac{1}{4}$ " deep recess of the largest possible diameter is turned in the open end of the rim.
- The rim is removed from the lathe and stock for the bottom is mounted in its place on a second faceplate. This is turned to size – and a rim about  $\frac{1}{4}$ " deep is turned to exactly fit the recess prepared in the rim.
- The rim is then fitted over the bottom and glued, making a drum shape with a faceplate at each end.
- This drum is cut completely in two at a point about  $\frac{1}{4}$ " above the bottom – completing the cut with a hand saw.
- Both parts of the cut surface are faced off square and smooth – then reglued together, breaking the joints exactly half and half. The cutting and regluing process is repeated with a section about  $1\frac{1}{4}$ " wide.
- After this, the temporary backing block is cut off, leaving the bowl as shown in the final illustration. From this point on, the work is simply a matter of turning down the bowl to any desired shape.

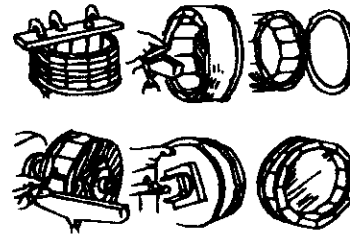

Figure 67

## TURNING PLASTICS

### TYPES OF PLASTICS

There are two general groups of plastics. The first includes all phenol plastics molded under heat and pressure. Bakelite and Formica are examples. In the second are all catalyst setting plastics of various bases sold under such trade names as Lucite, Catalin, Cast Bakelite, Marblette, Tenite and Trafford. Those in the second group are most generally used for craft work. They are easy to turn, being a little harder than wood, but much softer than any of the soft metals.

### MOUNTING THE WORK

The most useful mounting device is the 4-jaw (metal lathe) chuck. When this is not available, cylinders can be mounted on a slightly tapered wooden mandrel. Rods can be mounted between centers, using either the wood mounting centers or metal mounting arrangements. When the spur center is used, slots should be sawed across the work.

### USE OF WOOD TURNING CHISELS

Standard wood turning chisels are excellent for turning plastics by means of scraping methods.

- The tool rest should be slightly below center and the chisel handle should be held a little higher than the cutting edge to give a negative rake.
- Scraping tools should be kept to a minimum. A large contact area, such as the full edge of the spear-point chisel, will cause chatter and probable chipping.
- Properly worked, the chip comes off in a continuous ribbon.
- In cold weather, plastic may become brittle and should be tempered in warm water for about ten minutes before turning.

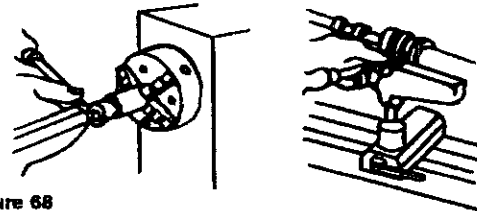

Figure 68

### USE OF FORMED TOOLS FOR PRODUCTION BEADING AND SIMILAR OPERATIONS

When a number of identical pieces are to be produced, all having a distinctive surface pattern, preformed tools will speed the work and assure uniformity. Patterns like those illustrated can be created by grinding thin (.020 to .010") gauge aluminum strips. A holder, like the one shown, can then be used to support any of your prepared strips and to guide it against the workpiece. See Figure 69, page 19.

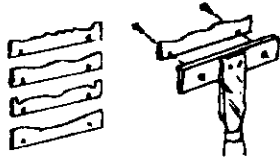

Figure 69

### TURNING BALLS

Plastic balls are rough turned in the usual manner and then brought to perfect roundness by using a tube tool. The tube should be slightly less in diameter than the finished size of the ball. It can be brass or steel, ground square across the end. The tool is used with or without a rest, and is worked by swinging it from side to side.

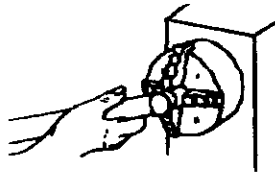

Figure 70

### POLISHING PLASTICS

Start with sanding.

- First use 150-grit dry paper to remove tool marks.
- Then finish off with 150-grit and 400-grit papers, in succession. These abrasives should be wet.
- Press lightly to avoid overheating and marring the work.
- Buffing gives the final polish, using the polishing compounds commonly supplied for this purpose. Do not press too hard or hold the wheel at one spot too long – keep moving around – otherwise the plastic might become heat marked.

### SANDING, BUFFING AND POLISHING

#### USING THE LATHE TO SAND TURNINGS

- Turnings should be sanded with the lathe running in second lowest speed.
- A large sheet of sandpaper is useful for smoothing cylinders.
- All other sanding operations are done with a narrow strip of abrasive paper. The best finishing grit is 3/0 for softwood, 4/0 for hardwoods. Worn 2/0 paper is often used, and is the equivalent of 3/0 or 4/0 new paper.

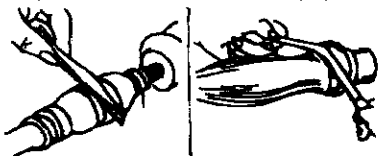

Figure 71

The application of the sandpaper strip is shown in the illustrations.

- Care must be exercised in order to prevent dubbing the corners of beads, shoulders, etc.

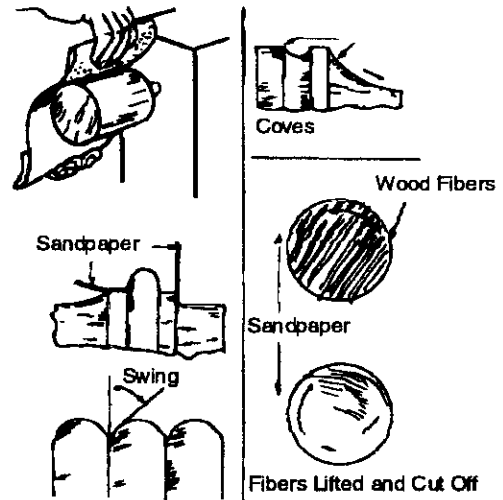

Figure 72

### USE OF SANDING DRUMS

Refer to Figure 73.

Standard sanding drums are usually rubber cylinders which can be expanded to hold an abrasive sleeve in place. Similar cylinders, turned on the lathe and covered with abrasive paper, will be adequate for the job. These have the advantage that special sizes, tapers, etc. can be made. Adhesive papers must be glued to the cylindrical surface precisely and completely.

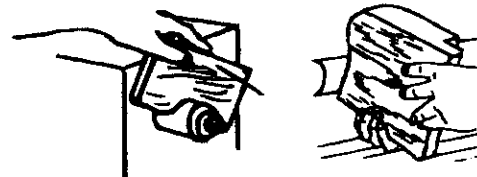

Figure 73

The drum is used mainly for sanding the edges of curved work.

- The squareness of the edge of the work can be best retained by using a simple form of vertical fence as shown.
- The standard sanding drums are commonly made with a threaded hole to fit the lathe drive spindle.
- To guard against loosening of the taper shank while the drum is in operation, it is advisable to support the free end, using either a ballbearing or plain 60° center in the tail stock.

### USE OF WOOD CHUCKS FOR SANDING

Quick-acting chucks can be very useful for sanding operations on duplicate production parts. The chuck is made slightly oversized, and a piece of rubber hose (for small parts) is inserted in the recess to grip the workpieces.



Figure 74

## MAINTENANCE

**WARNING:** Make certain that the unit is disconnected from power source before attempting to service or remove any component.

### CLEANING

Keep machine and workshop clean. Do not allow sawdust to accumulate on the tool. Keep centers clean.

Be certain motor is kept clean and is frequently vacuumed free of dust.

Use soap and water to clean painted parts, rubber parts and plastic guards.

### LUBRICATION

The shielded ball bearings in this tool are permanently lubricated at the factory. They require no further lubrication.

### KEEP TOOL IN REPAIR

- If power cord is worn, cut, or damaged in any way, have it replaced immediately.
- Replace any damaged or missing parts. Use parts list to order parts.

Any attempt to repair motor may create a hazard unless repair is done by a qualified service technician. Repair service is available at your nearest Sears store.

### REPLACING DRIVE BELT

Refer to Figures 75 and 77.

- Remove cover (3 screws)
- Loosen socket head bolt.
- Push motor towards bed and remove belt.
- Replace belt and assemble in reverse order.

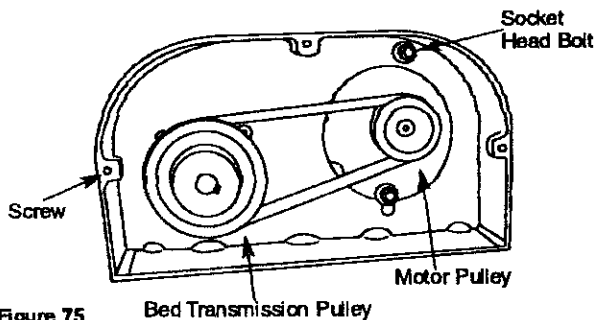

Figure 75

### REPLACING WORN VARIABLE SPEED BELT

Refer to Figures 76 and 77.

**NOTE:** Snap ring pliers are required for this operation.

- Remove rear cover (4 screws).
- Remove outboard spindle assembly and drive belt (3 screws).
- Remove snap ring, outboard spindle drive pulley, and stationary spindle pulley from spindle.
- Remove snap ring, cap, spring and pulley from drive shaft.

**CAUTION:** Cap is spring loaded and in tension.

- Remove and replace belt.
- Assemble in reverse order.

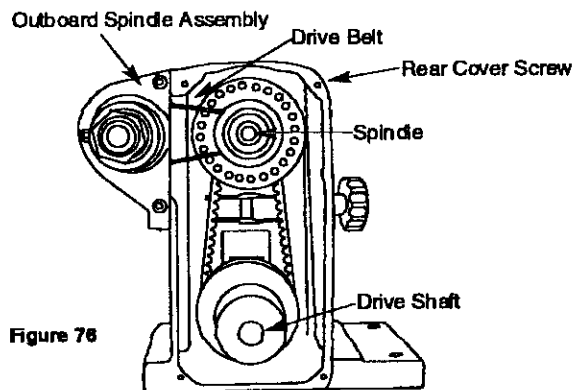

Figure 76

## TROUBLESHOOTING

SYMPTOM	POSSIBLE CAUSE(S)	CORRECTIVE ACTION
Motor will not start	<ol style="list-style-type: none"> <li>1. Low voltage</li> <li>2. Open circuit in motor or loose connections.</li> <li>3. Defective capacitor</li> </ol>	<ol style="list-style-type: none"> <li>1. Check power line for proper voltage</li> <li>2. Inspect all lead connections on motor for loose or open connection</li> <li>3. Replace capacitor</li> </ol>
Motor will not start; fuses blown or circuit breakers are tripped	<ol style="list-style-type: none"> <li>1. Short circuit in line cord or plug</li> <li>2. Short circuit in motor or loose connections</li> <li>3. Incorrect fuses or circuit breakers in power line</li> </ol>	<ol style="list-style-type: none"> <li>1. Inspect line cord or plug for damaged insulation and shorted wires</li> <li>2. Inspect all lead connections on motor for loose or shorted terminals or worn insulation on wires</li> <li>3. Install correct fuses or circuit breakers</li> </ol>
Motor fails to develop full power (power output of motor decreases rapidly with decrease in voltage at motor terminals)	<ol style="list-style-type: none"> <li>1. Power line overloaded with lights, appliances and other motors</li> <li>2. Undersize wires or circuits too long</li> <li>3. General overloading of power company's facilities</li> </ol>	<ol style="list-style-type: none"> <li>1. Reduce the load on the power line</li> <li>2. Increase wire sizes or reduce length of wiring</li> <li>3. Request a voltage check from the power company</li> </ol>
Motor overheats	Motor overloaded	Reduce load on motor
Motor stalls (resulting in blown fuses or tripped circuit breakers)	<ol style="list-style-type: none"> <li>1. Short circuit in motor or loose connections</li> <li>2. Low voltage</li> <li>3. Incorrect fuses or circuit breakers in power line</li> <li>4. Motor overloaded</li> </ol>	<ol style="list-style-type: none"> <li>1. Inspect connections in motor for loose or shorted terminals or worn insulation on lead wires</li> <li>2. Correct the low line voltage conditions</li> <li>3. Install correct fuses or circuit breakers</li> <li>4. Reduce load on motor</li> </ol>
Machine slows down while operating	<ol style="list-style-type: none"> <li>1. Applying too much pressure to work piece</li> <li>2. Motor drive belt loose</li> </ol>	<ol style="list-style-type: none"> <li>1. Ease up on pressure</li> <li>2. Reposition motor to add tension to drive belt</li> </ol>
Tool "chatters" during turning operation	<ol style="list-style-type: none"> <li>1. Workpiece is too far out-of-round</li> <li>2. Workpiece has too much wobble</li> <li>3. Operator using bad technique</li> <li>4. Cutting motion is against the grain of the workpiece</li> <li>5. Workpiece is too long and thin – workpiece is deflected by tool pressure</li> </ol>	<ol style="list-style-type: none"> <li>1. True up the roundness of the workpiece before turning operation</li> <li>2. Establish new center marks on ends to reduce wobble</li> <li>3. Read instructions and take lighter cuts to minimize chatter</li> <li>4. Use cutting motion that is with the grain</li> <li>5. Install a steady rest in the middle, behind the workpiece</li> </ol>
Workpiece splits or "breaks up" during turning operation	Workpiece contained defects before mounting	Select or assemble a workpiece that is free of defects

## NOTES

## NOTES

# Model 351.217120

## Figure 77 - Replacement Parts Illustration for Lathe

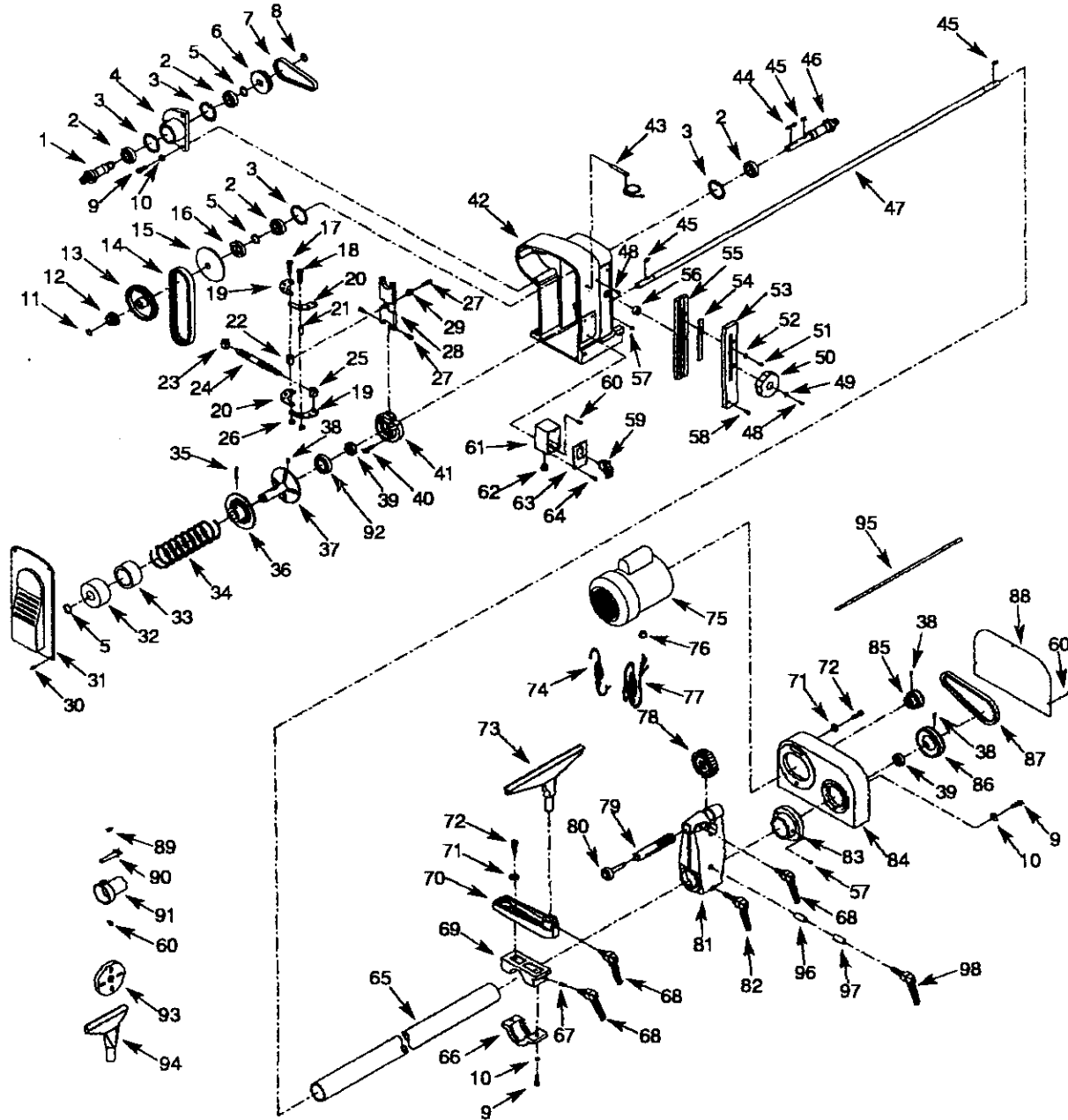



## REPLACEMENT PARTS LIST FOR LATHE

KEY NO.	PART NO.	DESCRIPTION	QTY.
1	18120.00	Outboard Spindle	1
2	STD315555	6005zz Ball Bearing*	4
3	18121.00	3BMI-47 Retaining Ring	4
4	18122.00	Spindle Seat	1
5	01900.00	3AMI-25 Retaining Ring	3
6	18123.00	Outboard Spindle Pulley	1
7	18124.00	Drive Belt	1
8	00256.00	3AMI-20 Retaining Ring	1
9	00483.00	8-1.25 x 25mm Socket Head Bolt	8
10	STD852008	8mm Lock Washer*	8
11	00341.00	3AMI-17 Retaining Ring	1
12	18125.00	Outboard Spindle Drive Pulley	1
13	18126.00	Stationary Spindle Pulley	1
14	18127.00	Variable Speed Belt	1
15	18128.00	Movable Spindle Pulley	1
16	18129.00	51106 Bearing	1
17	16453.00	6-1.0 x 40mm Socket Head Bolt	1
18	01097.00	6-1.0 x 35mm Socket Head Bolt	4
19	18130.00	Plate	2
20	18131.00	Plate	2
21	18132.00	Spacer	4
22	18133.00	Link	1
23	18134.00	Nut (LH)	1
24	18135.00	Adjusting Screw	1
25	18136.00	Nut (RH)	1
26	00961.00	6-1.0mm Hex Nut	5
27	01760.00	6-1.0 x 16mm Socket Head Bolt	3
28	18137.00	Adjusting Plate	1
29	18138.00	Bushing	1
30	05479.00	6-1.0 x 16mm Pan Head Screw	4
31	18139.00	Headstock Cover	1
32	18140.00	Cap	1
33	18141.00	Spring Retainer	1
34	18142.00	Spring	1
35	18143.00	Pin	1
36	18144.00	Movable Transmission Pulley	1
37	20063.00	Stationary Transmission Pulley	1
38	01043.00	6-1.0 x 8mm Set Screw	3
39	STD315225	6202zz Ball Bearing*	2
40	06410.00	8-1.25 x 16mm Socket Head Bolt	3
41	20064.00	Bearing Support	1
42	18147.00	Headstock Body	1
43	18148.00	Index Pin with Chain	1
44	02472.00	5 x 5 x 35mm Key	1
45	08335.00	5 x 5 x 18mm Key	3
46	18149.00	Spindle	1
47	18150.00	Transmission Shaft	1
48	01784.00	5-0.8 x 10mm Pan Head Screw	2
49	STD851005	5mm Flat Washer*	1

KEY NO.	PART NO.	DESCRIPTION	QTY.
50	18151.00	Knob	1
51	01930.00	4-0.7 x 6mm Pan Head Screw	1
52	18152.00	Pointer	1
53	18153.00	Rack Cover	1
54	18154.00	Rack	1
55	18155.00	Guide	1
56	18156.00	Bushing	1
57	01282.00	8-1.25 x 6mm Set Screw	2
58	01874.00	6-1.0 x 20mm Pan Head Screw	2
59	16080.00	Switch with Key	1
60	00389.00	5-0.8 x 12mm Pan Head Screw	7
61	18157.00	Switch Box	1
62	01680.00	Strain Relief	1
63	18158.00	Switch Plate	1
64	18060.00	5-0.8 x 10mm Tap Screw	3
65	18159.00	Bed Tube Assembly	1
66	18160.00	Tool Rest Bracket	1
67	18161.00	Pin	1
68	18162.00	Locking Handle	3
69	18163.00	Tool Rest Support	1
70	18164.00	Tool Rest Holder	1
71	STD851008	8mm Flat Washer*	4
72	00732.00	8-1.25 x 30mm Socket Head Bolt	4
73	18165.00	12" Tool Rest	1
74	18166.00	Motor Cord	1
75	18167.00	Motor	1
76	18168.00	Grommet	1
77	00067.00	Line Cord	1
78	18169.00	Handwheel	1
79	18170.00	Quill	1
80	9-25356	#1MT Bearing Center	1
81	20059.00	Tailstock Body	1
82	18172.00	Locking Handle	1
83	18173.00	Collar	1
84	18174.00	Motor Support	1
85	18175.00	Motor Pulley	1
86	18176.00	Transmission Shaft Pulley	1
87	18177.00	V-belt	1
88	18178.00	Cover	1
89	18179.00	Center Cup Insert	1
90	18180.00	Spur Center	1
91	18181.00	Cap	1
92	08637.00	6006ZZ Ball Bearing	1
93	9-22554	4" Faceplate	1
94	18183.00	6" Tool Rest	1
95	18193.00	Center Removal Rod	1
96	20057.00	Threaded Bushing	1
97	20058.00	Bushing	1
98	20060.00	Locking Handle	1
Δ	18184.02	Operator's Manual	1

\* Standard hardware item available locally

Δ Not Shown

PARTS LIST

# Model 351.217120

## Figure 78 - Replacement Parts Illustration for Stand

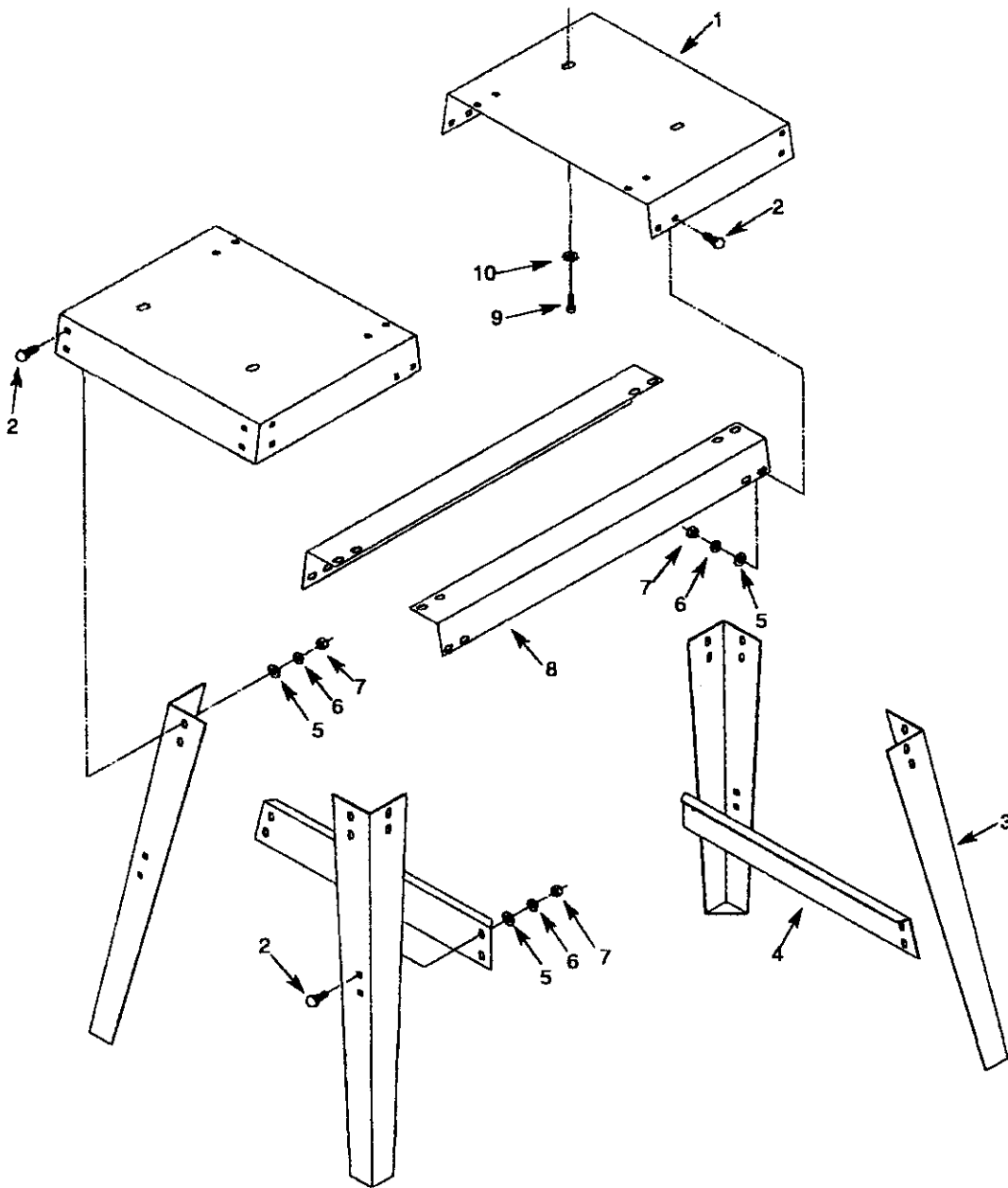

## REPLACEMENT PARTS LIST FOR STAND

KEY NO.	PART NO.	DESCRIPTION	QTY.
1	18185.00	Top	2
2	STD533107	<sup>5</sup> / <sub>16</sub> "-18 x <sup>3</sup> / <sub>4</sub> " Carriage Bolt*	40
3	18186.00	Leg	4
4	18187.00	Brace	2
5	STD551031	<sup>5</sup> / <sub>16</sub> " Flat Washer*	40
6	STD551131	<sup>5</sup> / <sub>16</sub> " Lock Washer*	40
7	STD541031	<sup>5</sup> / <sub>16</sub> " Hex Nut*	40
8	18188.00	Support	2
9	06410.00	8-1.25 x 16mm Socket Head Bolt	4
10	STD851008	8mm Flat Washer*	4
Δ	18189.00	4" Outboard Faceplate	-
Δ	18190.00	8" Outboard Faceplate	-

\* Standard hardware item available locally

Δ Not Shown

### RECOMMENDED ACCESSORIES

Δ	MT1 Work Arbor with Jacobs Chuck	9-25354
Δ	MT1 Work Arbor with Flanges	9-25355
Δ	MT1 60° Bearing Center	9-25356
Δ	MT1 Spur Center	9-25357
Δ	MT1 60° Center	9-25358
Δ	MT1 Screw Center	9-25359
Δ	MT1 Tailstock Cup Center	9-25360
Δ	4" Face Plate, 1"-8 TPI	9-29840
Δ	8" Face Plate, 1"-8 TPI	9-29841
Δ	6 <sup>1</sup> / <sub>2</sub> " x 4-Jaw Chuck, 1"-8 TPI	9-29842
Δ	Center Finder	9-25372
Δ	Robert Sorby Turning Tools (6 pc. set)	9-29830

Accessories available in catalog and larger retail stores.

## **Your Home**

For repair—in your home—of all major brand appliances,  
lawn and garden equipment, or heating and cooling systems,  
**no matter who made it, no matter who sold it!**

For the replacement parts, accessories and  
owner's manuals that you need to do-it-yourself.

For Sears professional installation of home appliances  
and items like garage door openers and water heaters.

**1-800-4-MY-HOME® (1-800-469-4663)**

Call anytime, day or night (U.S.A. and Canada)

[www.sears.com](http://www.sears.com)    [www.sears.ca](http://www.sears.ca)

---

## **Our Home**

For repair of carry-in items like vacuums, lawn equipment,  
and electronics, call or go on-line for the location of your nearest  
**Sears Parts & Repair Center.**

**1-800-488-1222**

Call anytime, day or night (U.S.A. only)

[www.sears.com](http://www.sears.com)

---

To purchase a protection agreement on a product serviced by Sears:

**1-800-827-6655 (U.S.A.)**

**1-800-361-6665 (Canada)**

---

Para pedir servicio de reparación  
a domicilio, y para ordenar piezas:

**1-888-SU-HOGAR<sup>SM</sup>**

(1-888-784-6427)

Au Canada pour service en français:

**1-800-LE-FOYER<sup>MC</sup>**

(1-800-533-6937)

[www.sears.ca](http://www.sears.ca)

# **SEARS**

® Registered Trademark / <sup>TM</sup> Trademark / <sup>SM</sup> Service Mark of Sears, Roebuck and Co.

® Marca Registrada / <sup>TM</sup> Marca de Fábrica / <sup>SM</sup> Marca de Servicio de Sears, Roebuck and Co.

<sup>MC</sup> Marque de commerce / <sup>MD</sup> Marque déposée de Sears, Roebuck and Co.

© Sears, Roebuck and Co.

## Free Manuals Download Website

<http://myh66.com>

<http://usermanuals.us>

<http://www.somanuals.com>

<http://www.4manuals.cc>

<http://www.manual-lib.com>

<http://www.404manual.com>

<http://www.luxmanual.com>

<http://aubethermostatmanual.com>

Golf course search by state

<http://golfingnear.com>

Email search by domain

<http://emailbydomain.com>

Auto manuals search

<http://auto.somanuals.com>

TV manuals search

<http://tv.somanuals.com>