

Owner's Manual

CRAFTSMAN®

42" SNOW BLADE

Model No. 486.24443

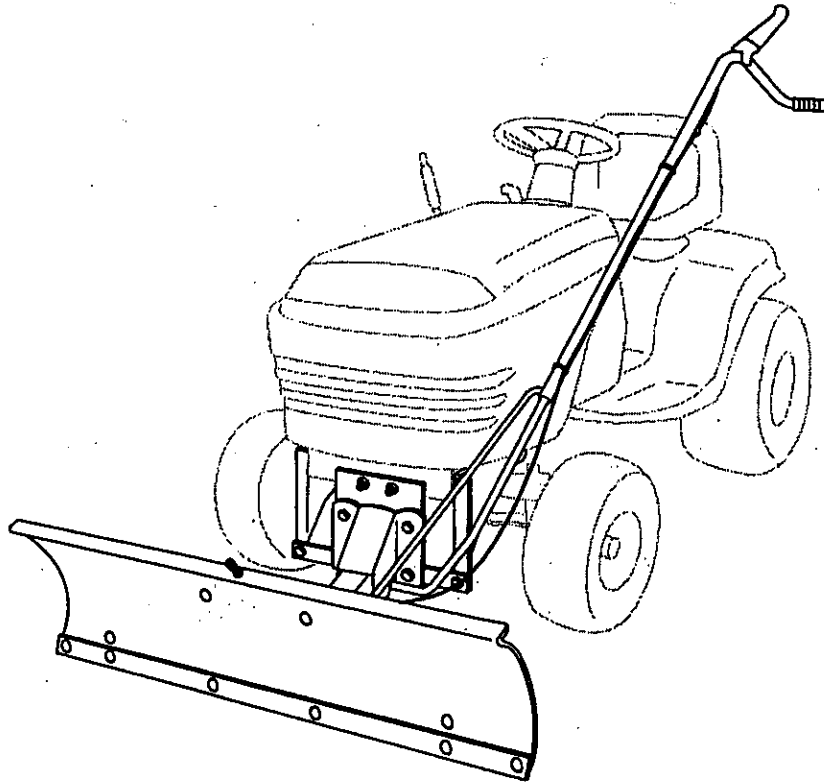

CAUTION:

Before using this product,
read this manual and follow
all Safety Rules and
Operating Instructions.

- Safety
- Assembly
- Operation
- Maintenance
- Parts

Sears, Roebuck and Co., Hoffman Estates, IL. 60179 U.S.A.

TABLE OF CONTENTS

SAFETY RULES.....	2	SERVICE AND ADJUSTMENTS.....	12
ACCESSORIES.....	3	STORAGE.....	12
FULL SIZE HARDWARE CHART.....	3	TROUBLESHOOTING.....	13
CARTON CONTENTS.....	4	REPAIR PARTS ILLUSTRATION.....	14
ASSEMBLY.....	5-9	REPAIR PARTS LIST.....	15
OPERATION.....	10-11	PARTS ORDERING/SERVICE.....	BACK COVER
MAINTENANCE.....	11		

WARRANTY

LIMITED ONE YEAR WARRANTY ON 42" SNOW BLADE

For one year from the date of purchase, when this snow blade is maintained and lubricated according to the operating and maintenance instructions in the owner's manual, Sears will repair any defect in material or workmanship free of charge. If this snow blade is used for commercial or rental purposes, this warranty applies for only 90 days from the date of purchase.

This warranty does not cover repairs necessary because of operator negligence or abuse, including the failure to maintain the equipment according to instructions contained in the owner's manual.

WARRANTY SERVICE IS AVAILABLE BY CONTACTING THE NEAREST SEARS SERVICE CENTER/DEPARTMENT IN THE UNITED STATES.

This warranty applies only while this product is in the United States.

This warranty gives you specific legal rights, and you may also have other rights which vary from state to state. Sears, Roebuck and Co. D/817 WA. Hoffman Estates, Chicago, IL 60179



SAFETY



Any power equipment can cause injury if operated improperly or if the user does not understand how to operate the equipment. Exercise caution at all times, when using power equipment.

1. Read the tractor and snow blade owner's manuals and know how to operate your tractor before using tractor with snow blade attachment.
2. Never operate tractor and snow blade without wearing proper clothing suited to weather conditions and operation of controls.
3. Never allow children to operate tractor and snow blade, and do not allow adults to operate without proper instructions.
4. Always begin with transmission in first (low) gear and gradually increase speed as required.



Look for this symbol to point out important safety precautions. It mean--**Attention!! Become alert!! Your safety is involved.**

The model number and serial numbers will be found on a decal attached to the snow blade.

You should record both the serial number and the date of purchase and keep in a safe place for future reference.

MODEL NUMBER. 486.24443

SERIAL NUMBER: _____

DATE OF PURCHASE: _____

ACCESSORIES AND ATTACHMENTS

These accessories were available at most Sears retail outlets and service centers when you purchased your snow blade. Most Sears stores can order repair parts for you when you provide the model number of your snow blade.

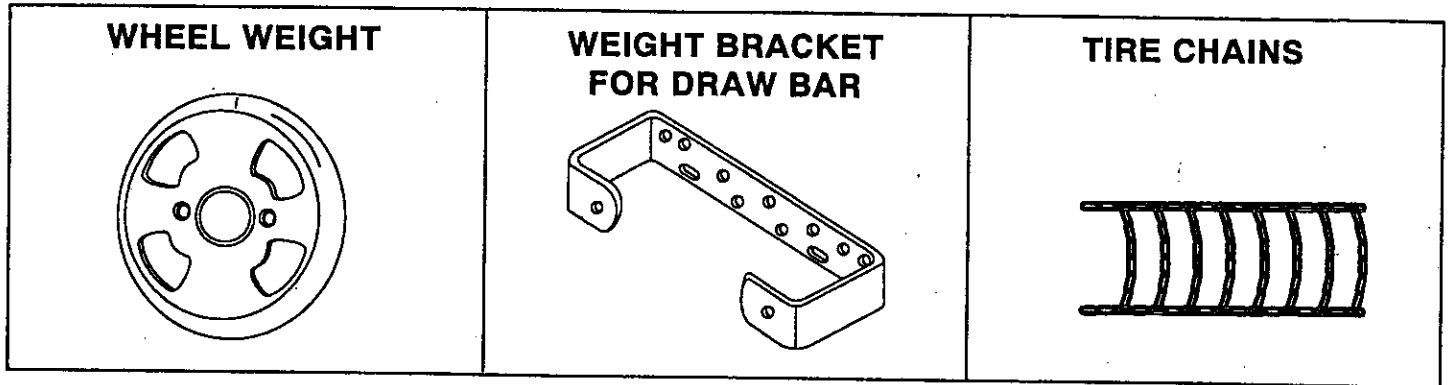

HARDWARE PACKAGE CONTENTS

(SHOWN FULL SIZE)

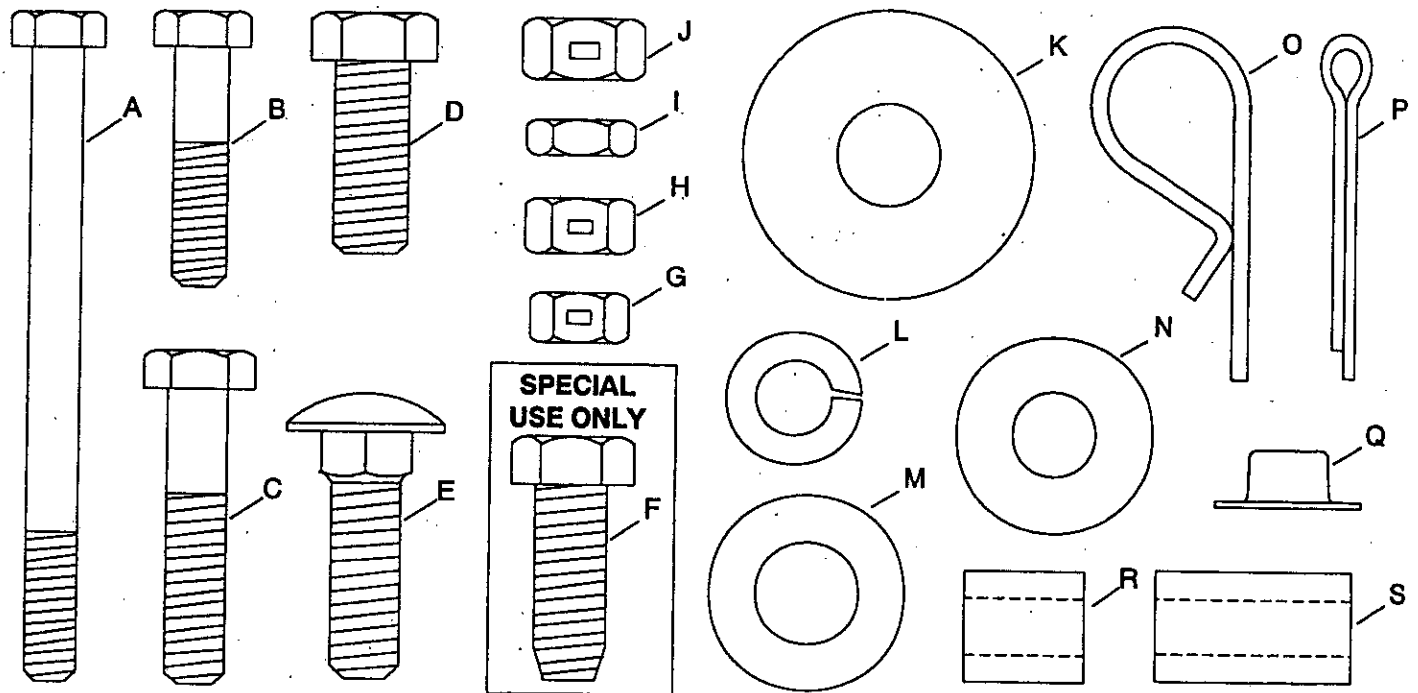

REF.	QTY.	DESCRIPTION	REF.	QTY.	DESCRIPTION
A	1	Hex Bolt, 1/4-20 x 3-1/4" LG.	K	2	Washer, Large 1/2"
B	1	Hex Bolt 1/4-20 x 1-1/4"	L	14	Lock Washer, 3/8"
C	1	Hex Bolt, 5/16-18 x 1-1/2"	M	1	Washer 1/2"
D	12	Hex Bolt, 3/8-16 x 1"	N	4	Washer, 3/8" STD.
E	2	Carriage Bolt 3/8-16 x 1-1/4"	O	4	Hairpin Cotter
F	2	Hex Bolt, 3/8" x 1" (Thread Forming)	P	2	Cotter Pin 1/8" x 1-1/4"
G	3	Hex Lock Nut, 1/4-20 Thread	Q	2	Palnut, 3/8"
H	1	Hex Lock Nut, 5/16-18 Thread	R	1	Spacer, 9/16" OD x 5/8" LG.
I	4	Hex Jam Nut, 5/16-24 Thread	S	2	Spacer, 9/16" OD x 1" LG.
J	12	Hex Lock Nut, 3/8-16 Thread			

PARTS IN HARDWARE PACKAGES NOT SHOWN FULL SIZE

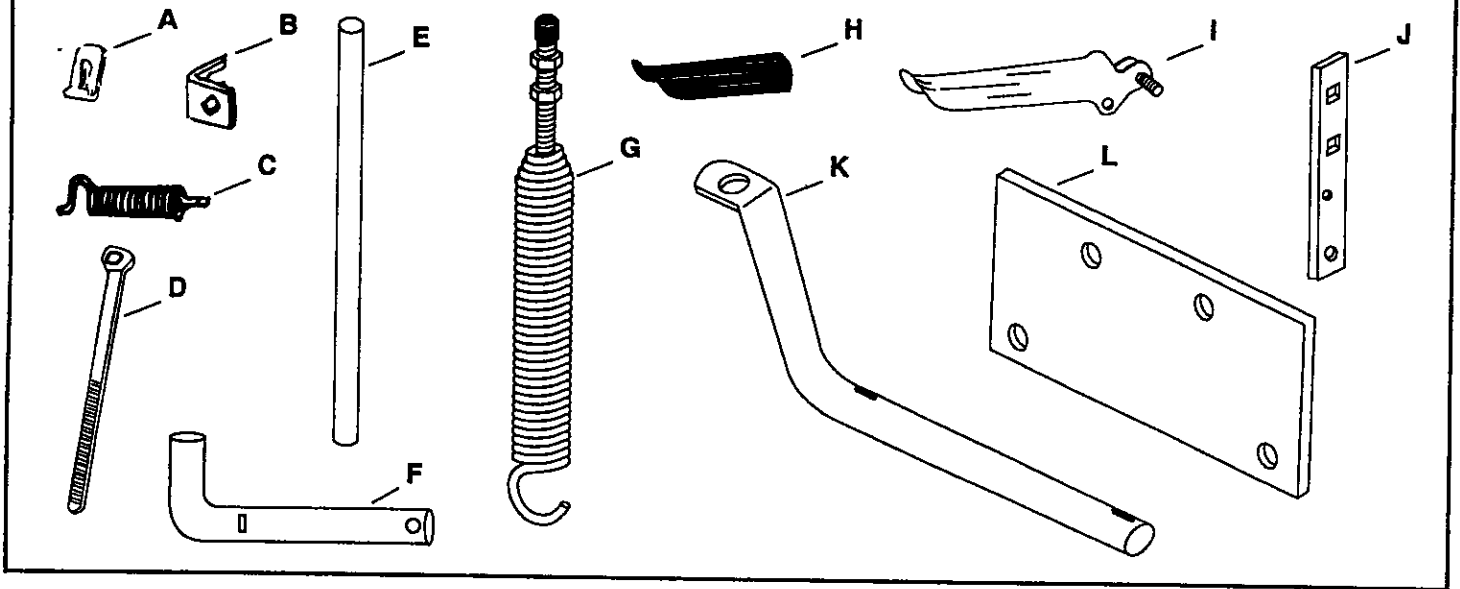

REF.	QTY.	DESCRIPTION	REF.	QTY.	DESCRIPTION
A	2	Cable End Fitting	G	1	Blade Adjust Spring
B	1	Cable Mount Bracket	H	1	Plastic Grip
C	1	Angle Lock Spring	I	1	Grip Assembly
D	2	Nylon Tie	J	2	Angle Lock Bars
E	1	Spring Mount Rod	K	1	Blade Pivot Shaft
F	1	Channel Pivot Pin	L	1	Pivot Plate Bracket

CARTON CONTENTS (Loose Parts in Carton)

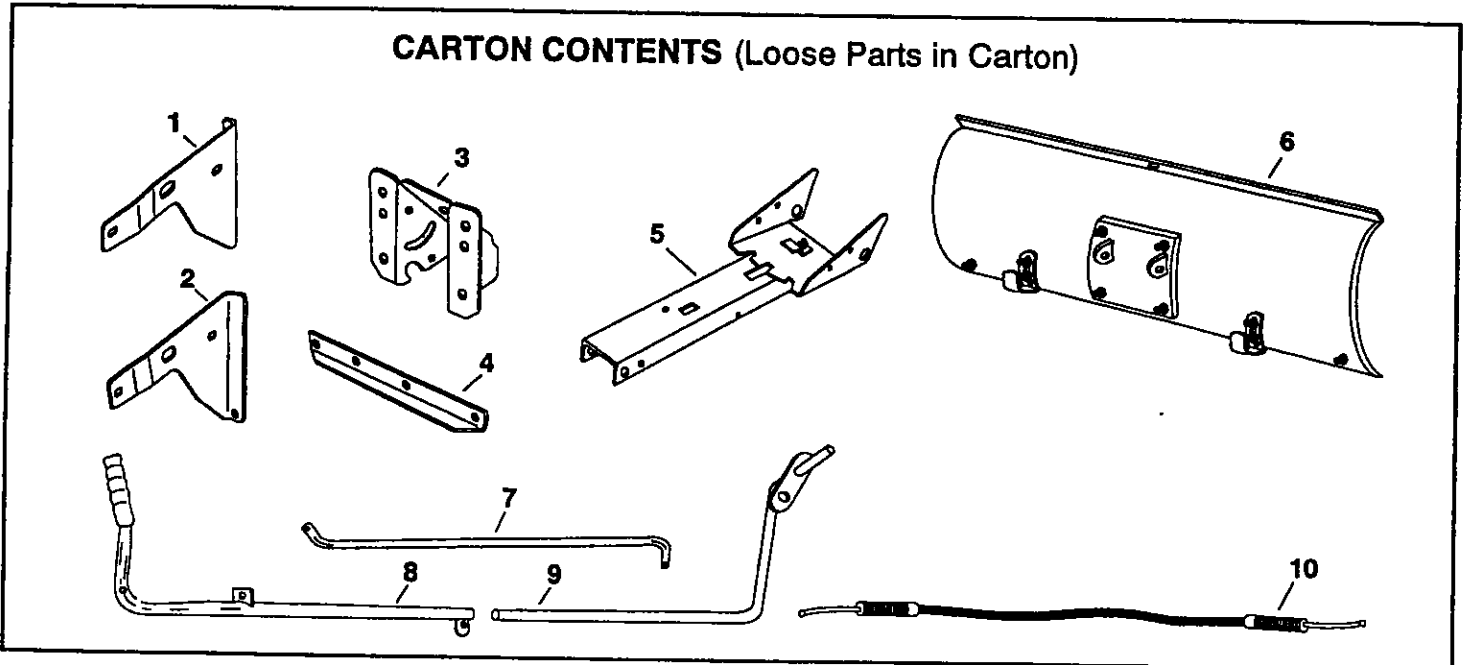

REF.	QTY.	DESCRIPTION	REF.	QTY.	DESCRIPTION
1	1	Hanger Bracket, L.H.	6	1	Blade Assembly
2	1	Hanger Bracket, R.H.	7	1	Blade Pivot Rod
3	1	Pivot Support Bracket	8	1	Lift Handle Tube
4	1	Cross Tie Bracket	9	1	Lift Handle Rod
5	1	Channel Assembly	10	1	Cable

ASSEMBLY

TOOLS REQUIRED FOR ASSEMBLY

- (1) Pliers
- (1) Hammer
- (1) Adjustable Wrench (or socket set)
- (1) 9/16" Open End or Box End Wrench
- (1) 7/16" Open End or Box End Wrench
- (1) 1/2" Open End or Box End Wrench

REMOVAL OF PARTS FROM CARTON

- Remove the loose parts and the hardware packages from the carton. Lay out all parts and hardware and identify using the illustrations on pages 3 and 4.

NOTE: Right hand (R.H.) and left hand (L.H.) are determined from the operators position while seated on the tractor.



CAUTION: Do not begin assembling until the tractor engine, muffler and exhaust deflector have been allowed to cool off.

TRACTOR PREPARATION

- Allow engine, muffler and exhaust deflector to cool before beginning.
- Refer to tractor owner's manual to remove mower deck or any other attachment you may have mounted to your tractor. Mark all loose parts and save for re-assembly.
- Refer to tractor owner's manual to remove tractor hood for easier assembly of blade to tractor frame.

IF YOUR TRACTOR HAS FRONT SUSPENSION BRACKETS LIKE FIGURE 1

- Remove two bolts from each side of the tractor frame as shown in figure 1.

NOTE: Bolts should be assembled back into the holes if the hanger brackets (figure 2) are removed from the tractor frame.

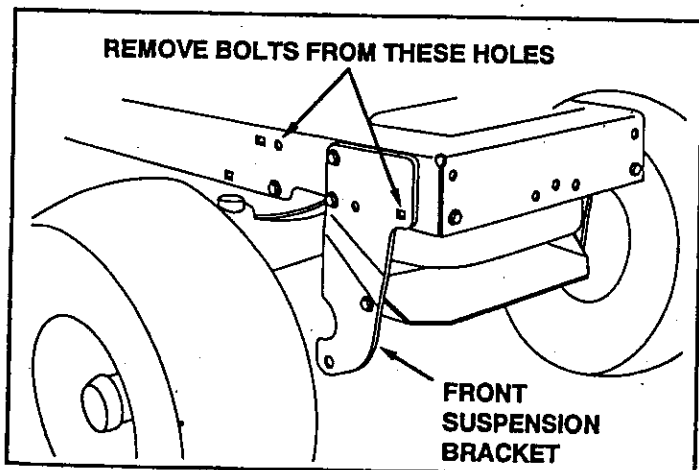

FIGURE 1

- Attach the R.H. hanger bracket to the empty holes on the right side of the tractor frame using two new 3/8" x 1" hex bolts, 3/8" lock washers, and 3/8" flat washers as shown in figure 2. **Tighten.** Repeat for the left side.

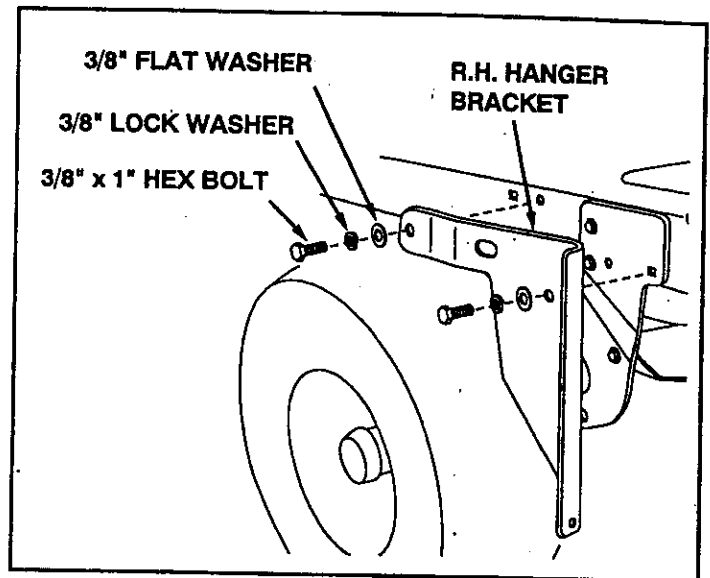

FIGURE 2

- Skip over to instructions for figure 5 on page 6.

IF YOUR TRACTOR HAS FRONT SUSPENSION BRACKETS LIKE FIGURE 3

- Remove the bolt from the hole shown in figure 3 on both the right and left sides of the tractor frame.

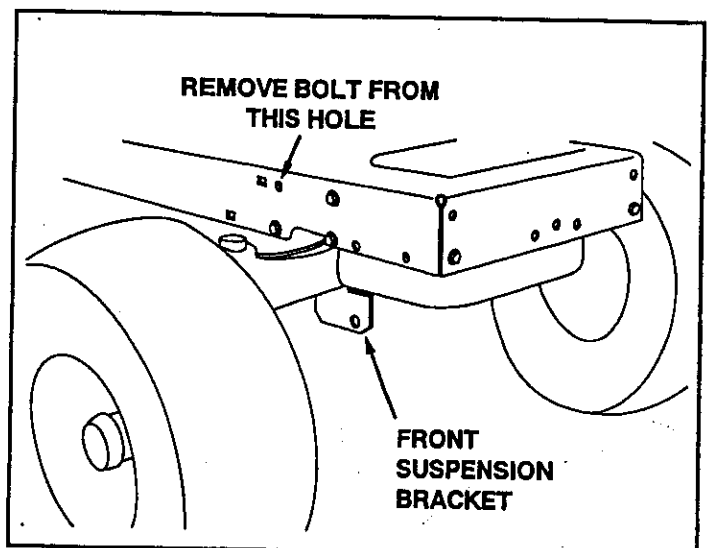

FIGURE 3

- Attach the R.H. hanger bracket to the front hole on the side of the tractor frame using a new 3/8" x 1" hex bolt, 3/8" lock washer, 3/8" flat washer, 1/2" large flat washer and 3/8" hex lock nut. Place the large 1/2" flat washer between the bracket and the tractor frame. Attach the rear of the bracket using a new 3/8" x 1" hex bolt, 3/8" lock washer and 3/8" flat washer. **Tighten.** See figure 4. Repeat for other side.

NOTE: If the front holes in the frame are too small for the regular bolts, use the two special 3/8" x 1" thread forming bolts.

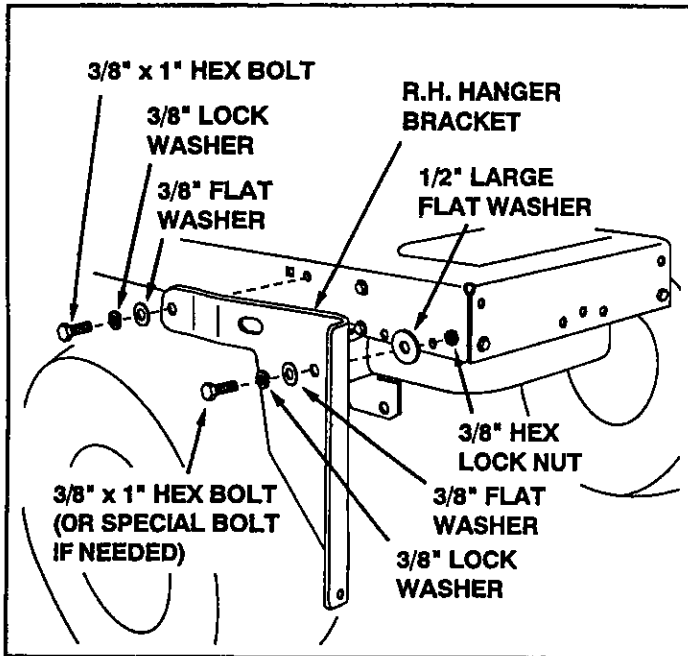

FIGURE 4

GENERAL ASSEMBLY INSTRUCTIONS

- Assemble the pivot plate bracket to the front of the tractor frame using two 3/8" x 1" hex bolts, two 3/8" lock washers and two 3/8" hex lock nuts. Make sure the bracket is straight and then **tighten.** See figure 5.

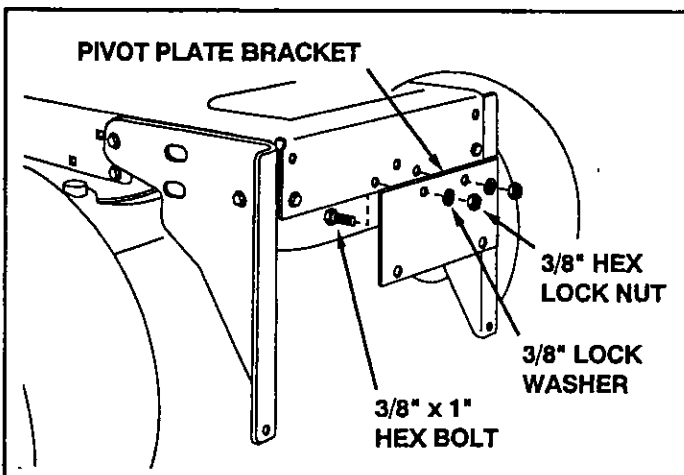

FIGURE 5

- Assemble the cross tie bracket to the bottom hole in both hanger brackets using two 3/8" x 1" hex bolts, two 3/8" lock washers and two 3/8" hex lock nuts. **Do not tighten yet.** See figure 6.
- Assemble the pivot support bracket to the pivot plate bracket and the cross tie bracket using four 3/8" x 1" hex bolts, four 3/8" lock washers and four 3/8" hex lock nuts. **Do not tighten yet.** See figure 6.
- **Tighten** the 2 bolts fastening the cross tie bracket to the hanger brackets. (Figure 6)
Tighten the 4 bolts fastening the pivot support bracket to the pivot plate bracket and the cross tie bracket. (Figure 6)

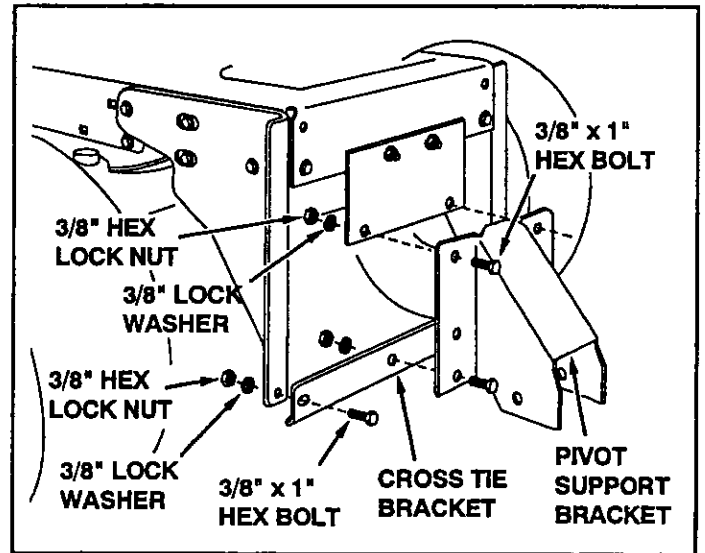

FIGURE 6

- Assemble the two angle lock bars together as shown in figure 6, so that all holes are aligned. Use one 3/8" x 1-1/4" carriage bolt, one 3/8" lock washer and one 3/8" hex lock nut. Be sure to insert bolt from side indicated. **Do not tighten at this time.** See figure 7.

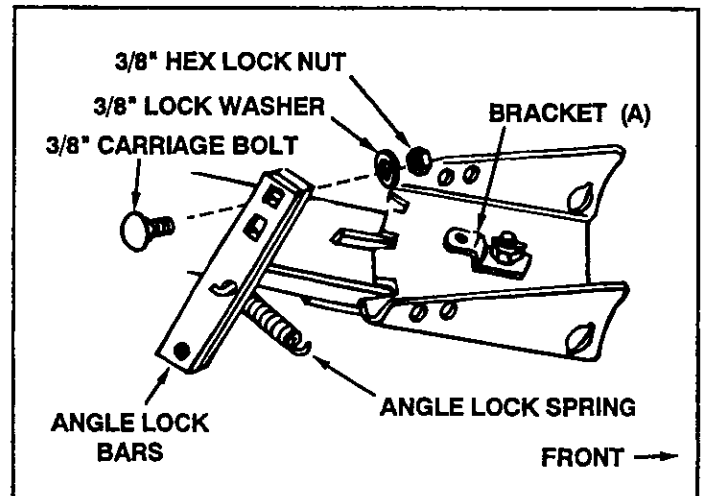

FIGURE 7

(Right Hand Side View)

- Insert the round hook end of the angle lock spring up through the hole in bracket (A). See figure 8.
- Hold the angle lock bars so that the square holes at the top. Insert the straight hook end of the angle lock spring through the middle hole in both angle lock bars as shown in figure 8.
- Insert the angle lock bars down through the slot in the channel. Underneath the channel, place a 1" long spacer on each side of the angle lock bars and insert a 1/4" x 3-1/4" bolt through the channel, the angle lock bars and the spacers. Secure the bolt with a 1/4" lock nut. **Tighten** so that lock bars can pivot freely. See figure 8.
- At this time **tighten** the 3/8" carriage bolt and hex nut previously assembled to angle lock bars.

NOTE: When the angle lock bars are pulled back in slot, the pivot plate should unlock and be free to pivot to the right or left position.

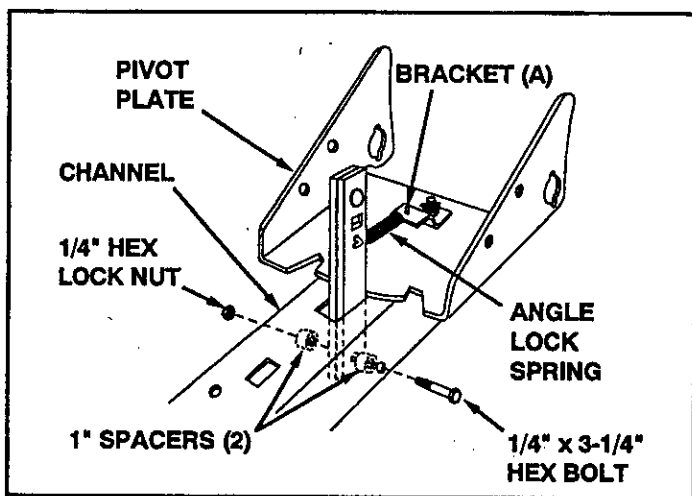

FIGURE 8 (Right Hand Side View)

- Using a hammer, assemble a 3/8" palnut onto one end of the spring mount rod. Insert the other end of the spring mount rod through the pivot plate using the rear set of holes. Support the assembled end of the spring mount rod on a block of wood, and hammer the remaining palnut onto the other end of the rod. See figure 9.

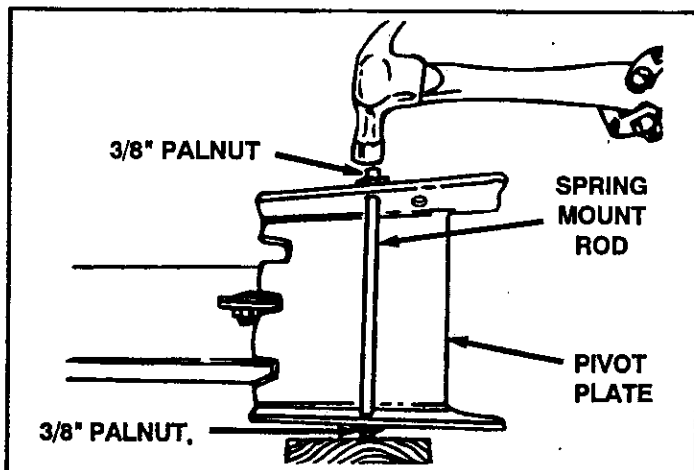

FIGURE 9 (Top View)

- Assemble a 3/8" x 1-1/4" carriage bolt through the square hole in the cable mount bracket and through the square hole in the angle lock bars as shown in figure 10. (The carriage bolts should face in opposite directions.) Using pliers hold the cable mount bracket in position, angling down towards the L.H. hole in the channel as shown in figure 10. Secure with a 3/8" lock washer and a 3/8" hex lock nut. **Tighten**. See figure 10. Refer also to figure 12 for the correct angle for the cable mount bracket.

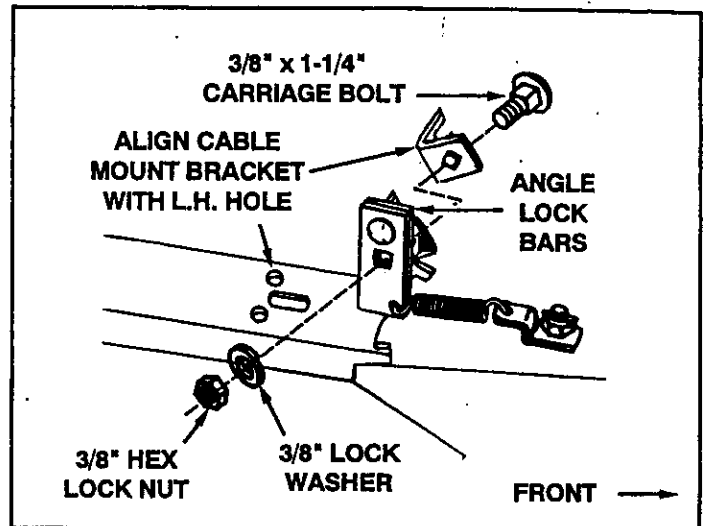

FIGURE 10 (Right Hand Side View)

- Assemble one 5/16" jam nut approximately 3/4" onto threaded end of control cable. Assemble threaded cable end through round hole in cable mount bracket as shown in figure 11, and secure with another 5/16" jam nut. **Tighten**. See figure 11.

NOTE: Some adjustment of jam nuts may be required after blade assembly is completed.

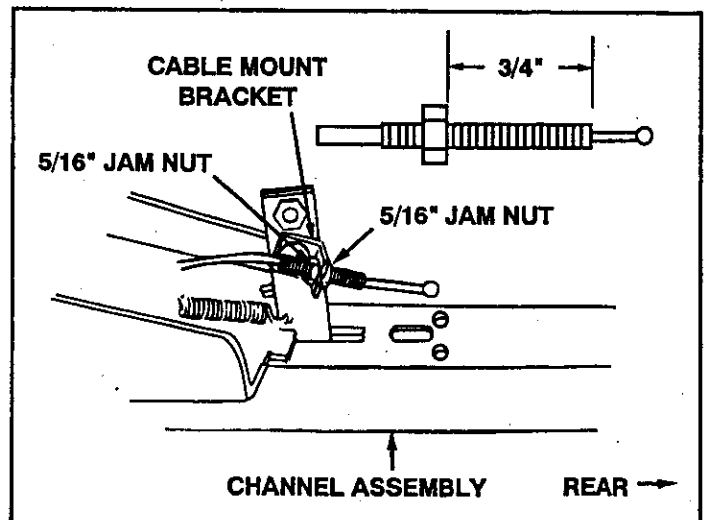

FIGURE 11 (Left Hand Side View)

- Assemble ball end of control cable up through hole in cable end fitting and pull until ball slips inside curled edge of fitting as shown in figure 12. If ball won't slip under edge of curl it will need to be inserted through open end of curl. See figure 12.
- Assemble 1/4" x 1-1/4" hex bolt down through the cable end fitting, the 5/8" long spacer and the left hand hole in the channel assembly. Secure with a 1/4" hex lock nut. See figure 12. **Tighten.**

NOTE: Make sure the cable mount bracket is aligned with the cable end fitting as shown in figure 12 to prevent binding of cable. The other end of the control cable will be attached in a later step.

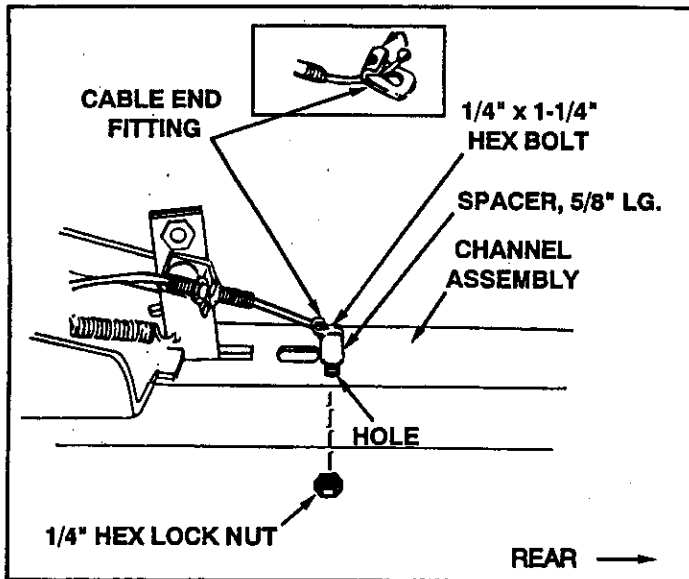

FIGURE 12 (Left Hand Side View)

- To attach the blade to the channel assembly, align the notched holes in the pivot plate with the notched holes in the blade. Insert a 1/8" x 1-1/4" cotter pin down through the hole at the bend in the blade pivot shaft. Spread the ends of the pin. From the left side insert the blade pivot shaft, bend facing up, through the notched holes. Secure the shaft with another 1/8" x 1-1/4" cotter pin through the end hole in the shaft. Spread the ends of the pin. See figure 13.
- Remove the plastic cap and one 3/8" hex nut from the bolt in the blade adjust spring. Adjust the remaining 3/8" hex nut down approximately 1" onto the bolt threads. Hook the spring over the spring mount rod as shown in figure 13. Place the bolt up through the hole in the top edge of the blade and reassemble the other 3/8" hex nut and tighten down against the top edge of the blade. Replace the plastic cap over the end of the bolt threads. See figure 13.

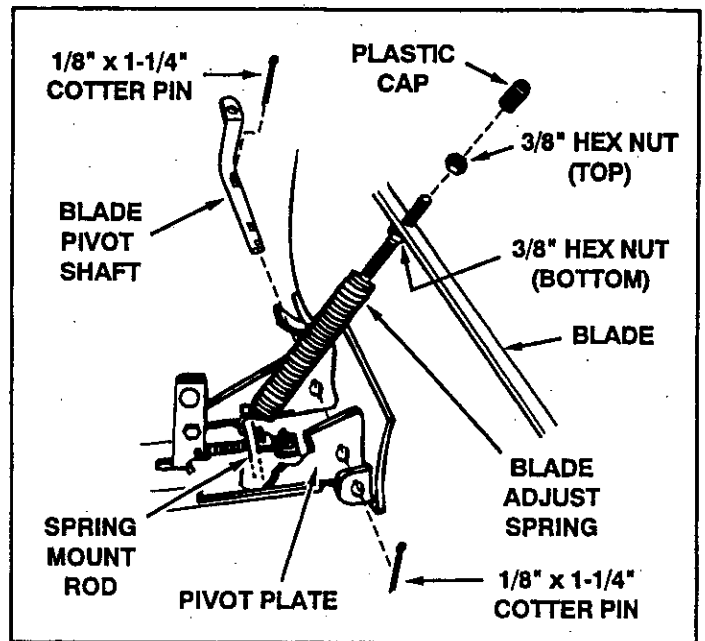

FIGURE 13 (Right Hand Side View)

- Assemble the 1/2" washer onto the channel pivot pin. See figure 14.
- Attach the channel assembly to the tractor by placing the end of the channel assembly up inside the pivot support bracket on the tractor. Align the hole in the pivot support bracket with the second hole from the end in the channel assembly. Insert the channel pivot pin through the aligned holes from the left side and secure with a hairpin cotter pushed all the way through to the loop end. See figure 14.

NOTE: All hairpin cotters on this snow blade should be pushed through to their loop end.

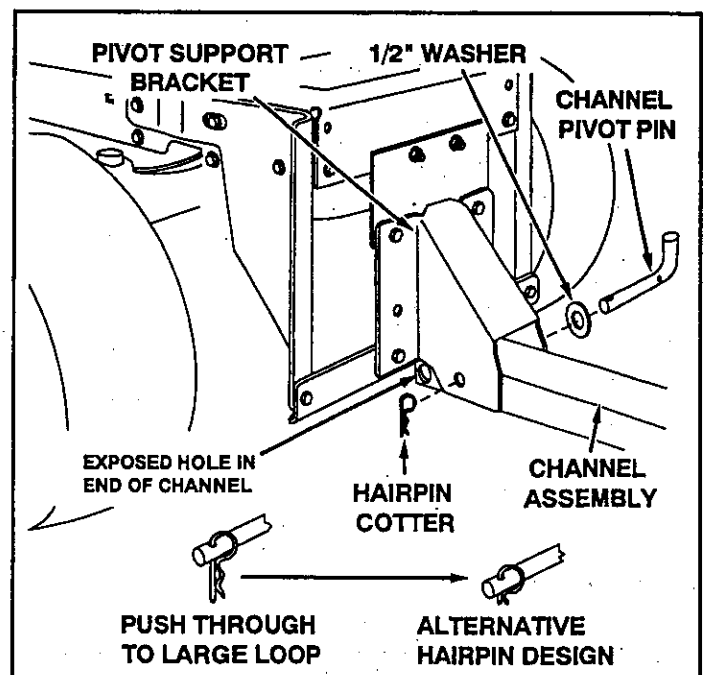

FIGURE 14 (Right Hand Side View)

- From the left side, insert the welded end of the lift handle rod through the exposed holes in the end of the channel assembly. Next, insert the lift link pin through the hole in the bracket that is welded to the lift handle rod. (The lift link is pre-assembled to the pivot support bracket). Secure the bracket with a hairpin cotter inserted up through the lift link pin all the way to the loop end of the hairpin cotter. See figure 15.
- Using the furnished grease packet, apply a light coating of grease to the straight upper portion of the lift handle rod. Slide the lift handle tube onto the rod. See figure 15.

- Assemble the plastic grip onto the lock release grip assembly. See figure 17.
- Attach the lock release grip assembly to the lift handle tube using one 5/16" x 1-1/2" hex bolt and one 5/16" hex lock nut. **Do not overtighten** the lock nut. The grip assembly must pivot freely. See figure 17.
- Assemble the ball end of the cable to a cable end fitting as was done to the other end of the cable. Secure the cable end fitting to the weld bolt on the lock release grip with a 1/4" hex lock nut. **Do not overtighten** the lock nut. The cable fitting must pivot freely. See figure 17.

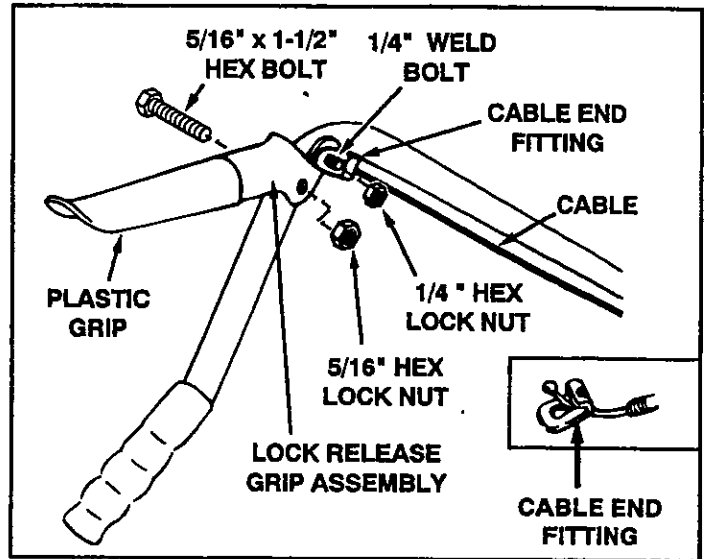
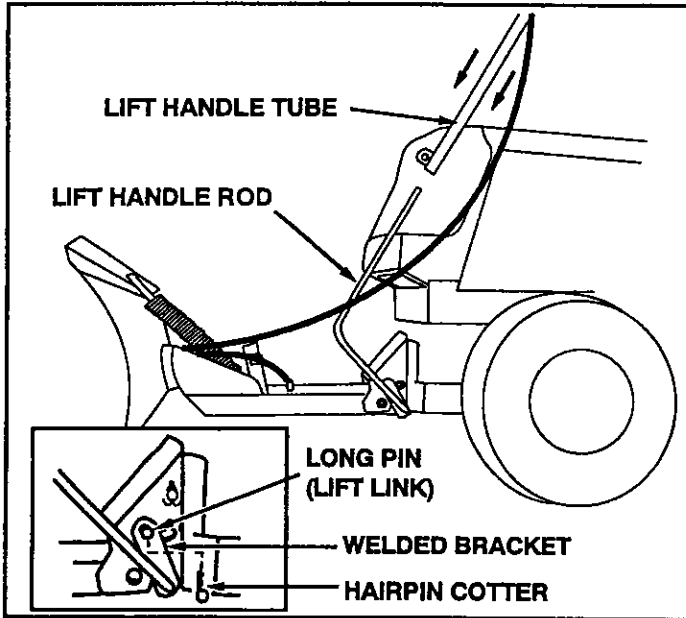

FIGURE 17 (Right Hand Side View)

FIGURE 15 (Left Hand Side View)

- Screw one 5/16" jam nut approximately 3/4" onto the loose end of the control cable. Pass the cable around the outside of the lift handle rod and insert the threaded cable end through the cable mount bracket on the lift handle tube. Secure the cable with another 5/16" jam nut. **Tighten**. See figure 16.

- Place the long end of the blade pivot rod down through the blade pivot shaft. Attach the short end of the blade pivot rod to the lift handle tube. Secure both ends with a hairpin cotter pushed through to its loop end. See figure 18.
- Use the two plastic ties to hold the cable securely to the outside of the handle tube and away from the tractor to avoid direct heat from the tractor muffler. See figure 18.

NOTE: Some adjustment of jam nuts may be required after blade assembly is completed.

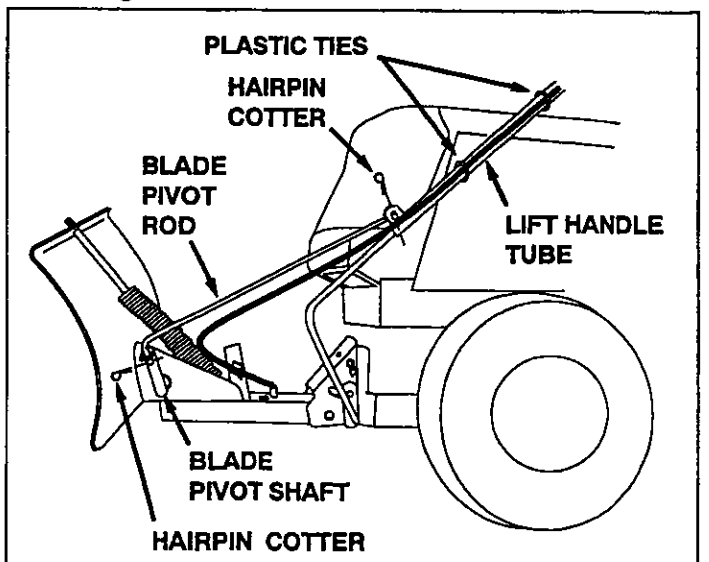
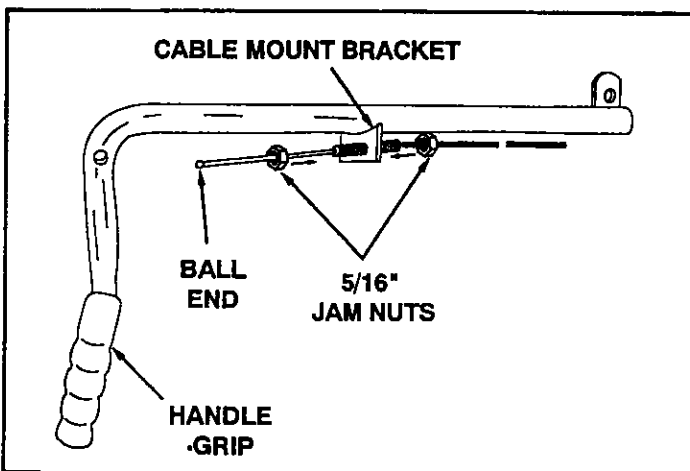

FIGURE 18 (Left Hand Side View)

FIGURE 16 (Right Hand Side View)

OPERATION

KNOW YOUR SNOW BLADE

Read this owner's manual and safety rules before operating your snowblade.

Compare the illustration below with your snow blade to familiarize yourself with the various controls and their locations.

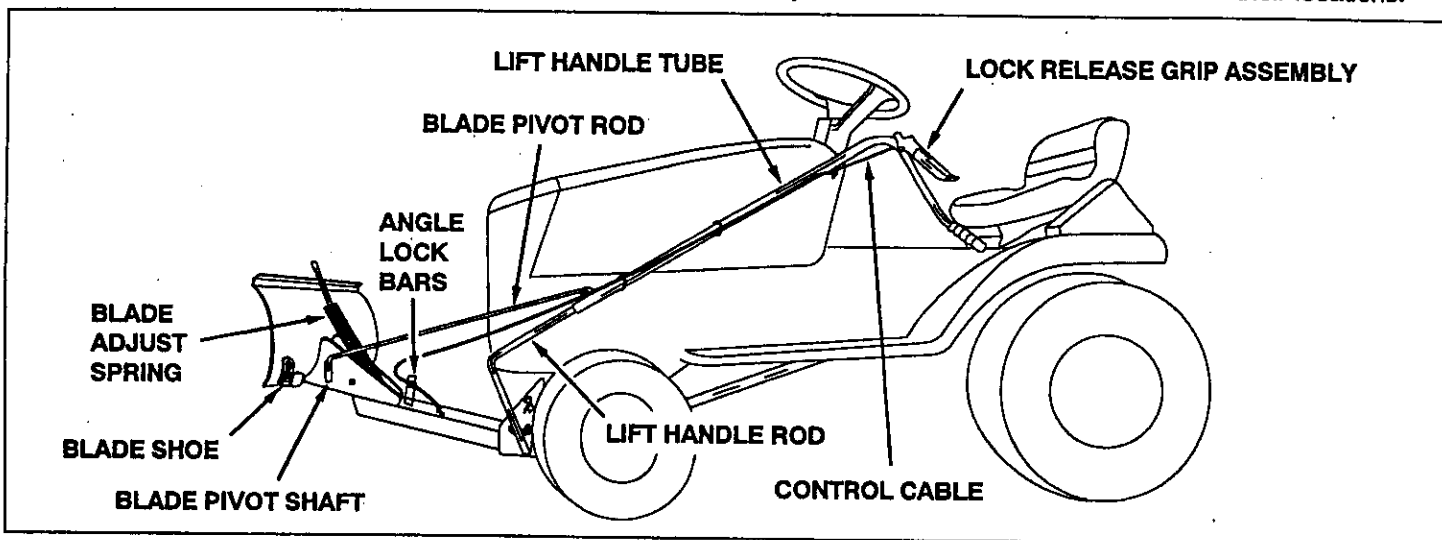

LOCK RELEASE GRIP ASS'Y.

Unlocks the blade to swivel to the right and left.

LIFT HANDLE TUBE

Raises or lowers the blade and pivots blade to the right and left.

BLADE PIVOT ROD

Connects blade to handle tube. Pivots blade to the right and left.

ANGLE LOCK BARS

Locks the blade in either the right hand, left hand or straight ahead position.

BLADE ADJUST SPRING

Holds blade in position but permits it to pivot forward to pass over an obstruction.

BLADE SHOE

Ground-contacting part of blade. Adjusts for adequate ground clearance of blade.

BLADE PIVOT SHAFT

Connects blade to channel assembly. Allows blade to pivot forward.

LIFT HANDLE ROD

Connects lift handle tube to channel assembly. Raises and lowers the blade.

CONTROL CABLE

Connects the lock release lever to the angle lock bars.

HOW TO USE YOUR SNOW BLADE

To Raise or Lower the Snow Blade

- Use the handle grip located on the end of the handle tube. To raise the blade, pull back while pushing down on the handle grip. To lower blade, pull back while lifting up on handle grip. See figure 19.

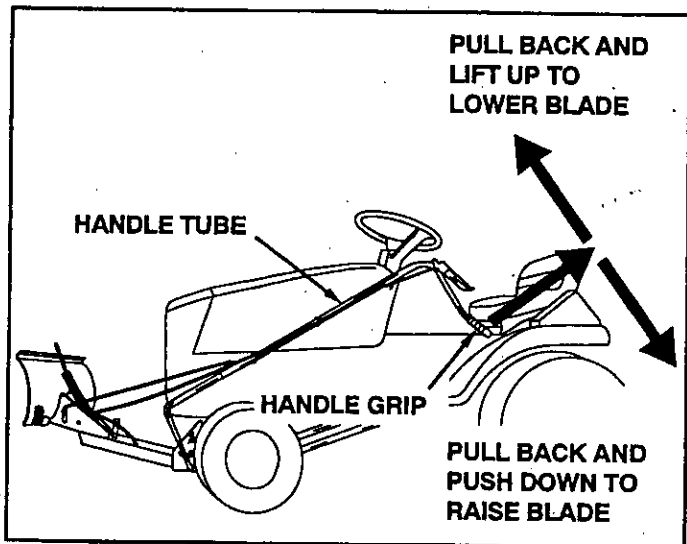

FIGURE 19

To Pivot the Blade

- Raise the blade to transport position. To unlock the blade, push the lock release grip down against the handle tube. To pivot the blade, keep the grip depressed and push forward or pull back on the handle tube, sliding it along the lift rod. Release the grip to lock the blade when it is in either the right hand, the left hand or the straight ahead position. See figure 20.

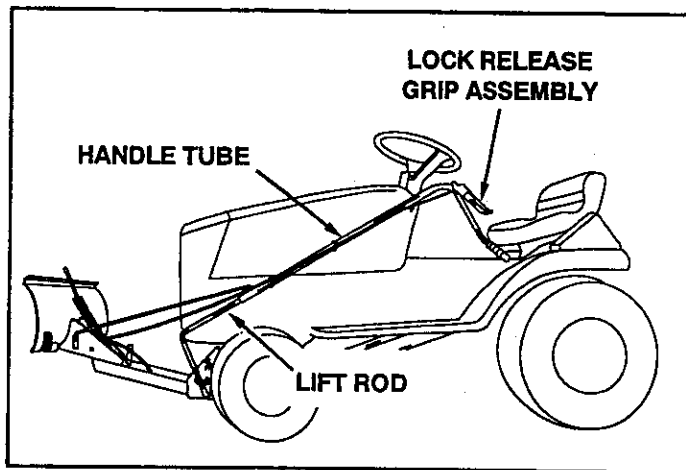

FIGURE 20

Wheel weights and tire chains must be used with your snow blade for traction. These accessories are available at your nearest Sears retail store.

Using the Snowblade

- Prepare the lawn tractor engine for cold weather using instructions furnished with the lawn tractor.
- Always begin with the transmission in first (low) gear and gradually increase speed as required.
- **Do not** repeatedly push snow in the same direction, causing excessive build up with each successive pass.
- To reduce icing on the blade, allow the lawn tractor and blade to adjust to outdoor temperature before operating.
- For improved snow removal performance, coat the blade with automotive type paste wax.



CAUTION: Inspect carefully the area to be worked before operating the snow blade. Avoid pipes, roots, curbs or other heavy obstructions.



CAUTION: Know the terrain. Avoid exceptionally steep slopes or drop offs which may be hidden by the snow. Never run the snow blade into heavy material at high speed.



CAUTION: Always lower the blade to the ground before leaving the tractor.

MAINTENANCE

CUSTOMER RESPONSIBILITIES

- Read and follow the maintenance schedule and the procedures listed in the maintenance section.

MAINTENANCE SCHEDULE Fill in dates as you complete regular service.	Service Dates											
	Before each use	After each use	Every season	Before storage								
Check for loose fasteners	X											
Check for worn or damaged parts	X											
Clean Blade		X	X									
Lubricate Blade			X									

- During the operating season, check all bolts, nuts and hairpin cotters to be sure they are secure.

Lubrication Points

- Lubricate all pivot points to help maintain proper operation of blade. Use grease packet furnished with the snow blade for lubrication of the upper portion of the lift handle rod. See figure 21.

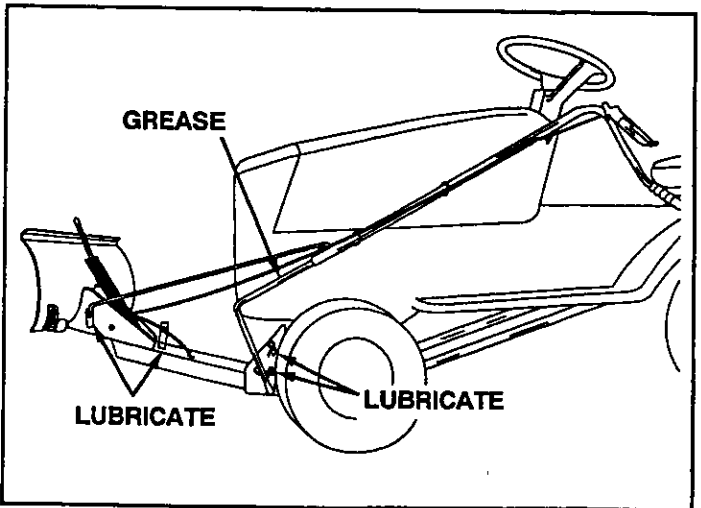

FIGURE 21

SERVICE AND ADJUSTMENTS

To Adjust Blade Spring

- The tension of the blade adjust spring may be altered to permit the blade to tilt forward to bypass solid obstructions. To change the spring tension, adjust the nuts at upper end of the spring bolt. Standing in front of blade, turn the nuts counterclockwise to relieve tension and clockwise to increase tension. Refer to figure 13 on page 8.

To Adjust Blade Shoes

- The blade shoes at the ends of blade may be raised for close work on smooth surfaces or lowered to raise the blade to work on rough or uneven areas. Make sure both shoes are set evenly and that the nuts are tightened securely. See figure 22.

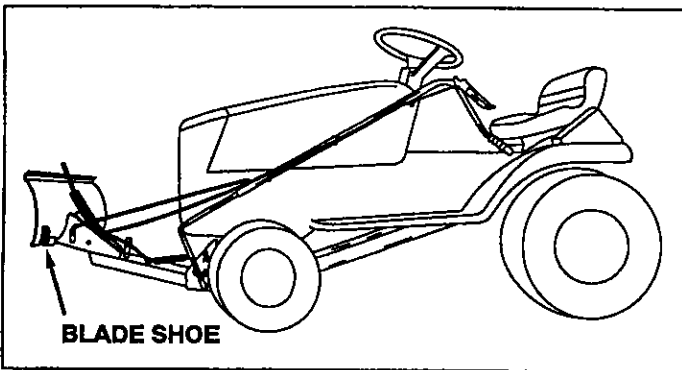

FIGURE 22

To Adjust the Blade Pivot Lock Mechanism

- If the blade will not unlock and pivot, the angle lock bars are not disengaging from the slots in the pivot plate. To correct, adjust the 5/16" hex jam nuts to draw the end of the control cable back towards the cable mount bracket. The less the threaded end of the cable extends through the bracket, the more the angle lock bars can retract to disengage from the slots in the pivot plate. See figure 23.

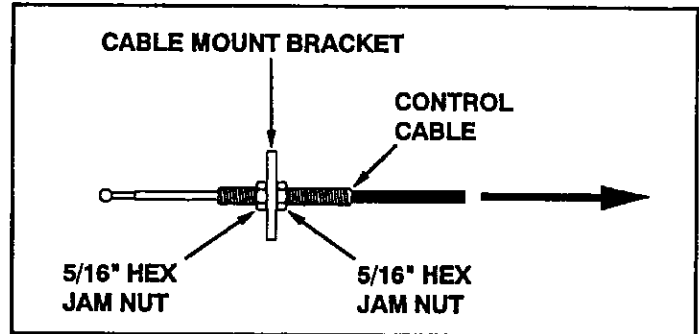

FIGURE 23

STORAGE

Recommendations When Storing

- When the snow blade is not being used, remove all dirt and rust and touch up with paint.
- Touch up bare metal with paint or apply a light coat of grease or rust preventive.
- Lubricate all pivot points and all points shown in figure 21, page 11 in the maintenance section.
- Store in a dry area, protected from weather.

To Remove Blade From Tractor

- Lower the blade to the ground with the blade in the center (straight ahead) position.
- Remove the hairpin cotter which fastens the blade pivot rod to the blade pivot shaft. See figure 18 on page 9.

- Remove the hairpin cotter which fastens the lift handle rod to the lift link pin. See figure 15, page 9.
- Remove the hairpin cotter from the channel pivot pin and remove the pivot pin from the channel assembly. See figure 14 on page 8.
- Remove the blade, the channel assembly and the lift handle assembly from the tractor. The brackets assembled to the tractor frame may be left in place.
- To remove the brackets assembled to the tractor frame (hanger brackets, cross tie bracket, pivot plate bracket and pivot support bracket) refer to figures 1,2,3,4,5 and 6 on pages 5 and 6.
- If the hanger brackets are removed from the tractor frame, be sure to reassemble four bolts into the empty holes in the frame. Refer to figures 1 and 3 on page 5.

TROUBLESHOOTING

PROBLEM	CAUSE	CORRECTION
Blade is difficult to raise.	Lift mechanism is binding	Lubricate pivot points as shown in figure 21 on page 11.
Blade is difficult to pivot.	Handle tube is binding on lift rod.	Lubricate lift handle rod as instructed on page 11.
Blade will not unlock to pivot.	Lock mechanism is out of adjustment and is not disengaging.	Refer to the Service and Adjustments section on page 12.

REPAIR PARTS FOR MODEL 486.24443 - 42" SNOW BLADE

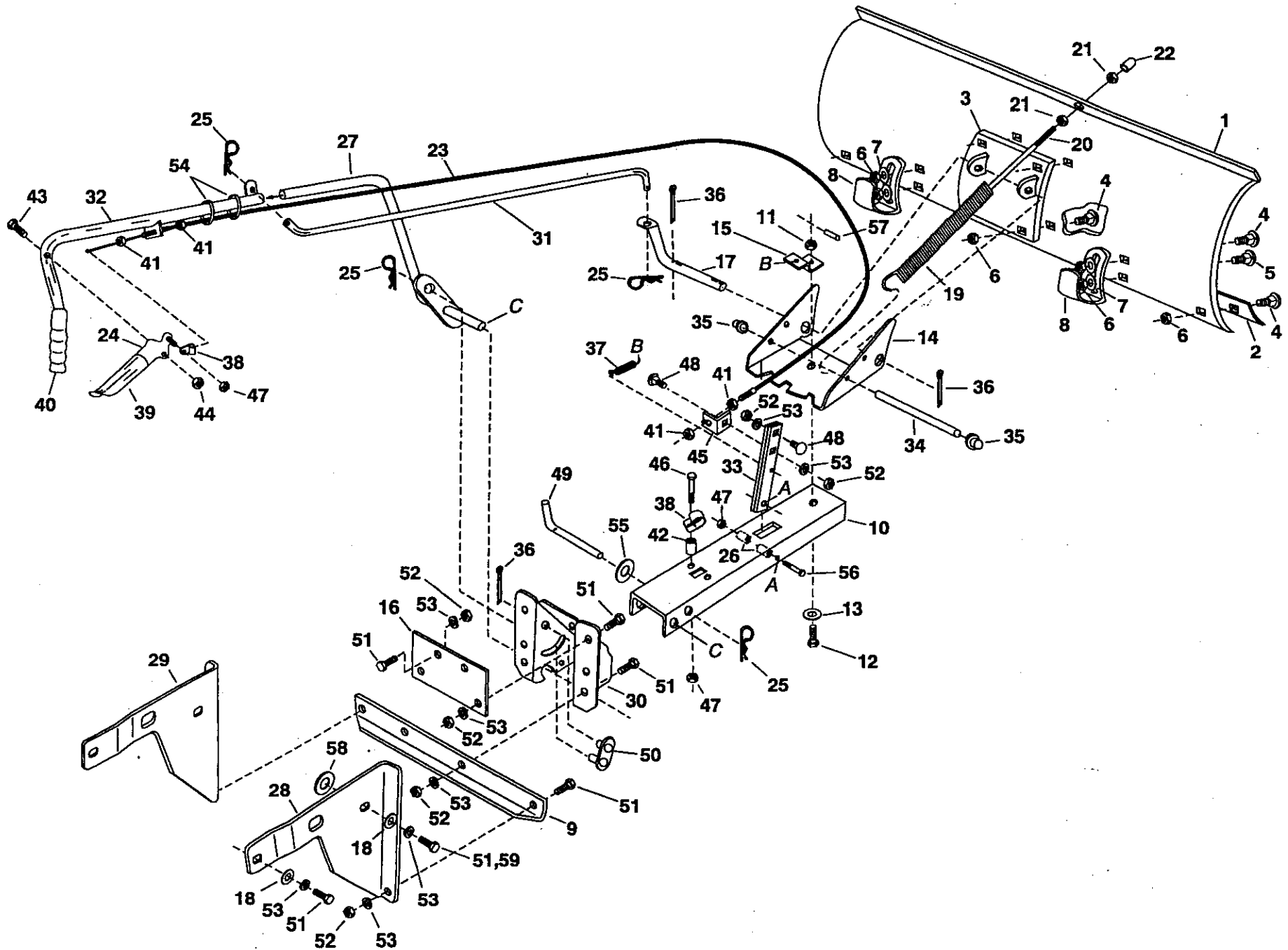

REPAIR PARTS LIST FOR MODEL 486.24443 - 42" SNOW BLADE

REF. NO.	PART NO.	QTY.	DESCRIPTION	REF. NO.	PART NO.	QTY.	DESCRIPTION
1	23863	1	Blade 42"	30	24023	1	Pivot Support Bracket
2	23117	1	Wear Plate 42"	31	46049	1	Rod, Blade Pivot
3	62980	1	Reinforcement Plate Assembly	32	62972	1	Lift Handle Tube Assembly
4	43080	8	Bolt, Carriage 5/16-18 x 3/4"	33	23151	2	Angle Lock Bar
5	43079	2	Bolt, Carriage 5/16-18 x 1"	34	23856	1	Spring Mount Rod
6	43064	10	Hex Lock Nut, 5/16-18 Thread	35	44917	2	Nut, 3/8"
7	43081	4	Washer, 5/16"	36	43010	3	Cotter Pin 1/8" x 1-1/4"
8	23070	2	Skid Shoe	37	43348	1	Angle Lock Spring
9	24346	1	Bracket, Cross Tie	38	746-0260	2	Cable End Fitting
10	24347	1	Push Channel	39	731-0869	1	Grip, Plastic
11	43262	1	Hex Lock Nut, 1/2-13 Thread	40	46471	1	Handle, Grip
12	23131	1	Bolt, Special Pivot	41	712-0256	4	Hex Jam Nut, 5/16-24 Thread
13	1540-118	1	Washer, Flat 1/2"	42	23658	1	Spacer
14	23958	1	Plate, Pivot 7 Ga.	43	43085	1	Hex Bolt, 5/16-18 x 1-1/2"
15	23130	1	Bracket, Spring Mt.	44	43064	1	Hex Lock Nut, 5/16-18 Thread
16	24345	1	Bracket, Pivot Plate	45	05762	1	Cable Mount Bracket
17	46066	1	Shaft, Blade Pivot	46	1509-90	1	Hex Bolt 1/4-20 x 1-1/4"
18	43070	4	Washer, 3/8" STD.	47	43013	3	Hex Lock Nut, 1/4-20 Thread
19	9466R	1	Spring, Blade Adjust	48	710-0305	2	Carriage Bolt, 3/8-16 x 1-1/4"
20	44071	1	Hex Bolt, 3/8-16 x 3-1/2"	49	46065	1	Channel Pivot Pin
21	43015	2	Hex Nut, 3/8-16 Thread	50	63034	1	Lift Link Assembly
22	44074	1	Plastic Cap	51	43001	12	Hex Bolt, 3/8-16 x 1"
23	746-0366	1	Control Cable Assembly	52	43082	10	Hex Lock Nut, 3/8-16 Thread
24	62561	1	Release Grip Assembly	53	43003	14	Lock Washer 3/8"
25	43055	4	Pin, Hairpin Small 3/32"	54	726-0178	2	Plastic Tie
26	46053	2	Spacer, .28 ID x 1"	55	R19171616	1	Washer
27	63033	1	Lift Handle Rod Assembly	56	46071	1	Hex Bolt, 1/4-20 x 3-1/4" Lg. Gr 5
28	24652	1	Hanger Bracket, R.H.	57	43349	1	1/4" x 1" Spring Pin
29	24651	1	Hanger Bracket, L.H.	58	R19172410	2	Washer, 1/2" (Large)
				59	47631	2	Hex Bolt, 3/8" x 1" (Thd. Forming)
					47723	1	Owners Manual

For in-home major brand repair service:

Call 24 hours a day, 7 days a week

1-800-4-MY-HOMESM (1-800-469-4663)

Para pedir servicio de reparación a domicilio – 1-800-676-5811

In Canada for all your service and parts needs call – **1-800-665-4455**
Au Canada pour tout le service ou les pièces

For the repair or replacement parts you need:

Call 7 am – 7 pm, 7 days a week

1-800-366-PART (1-800-366-7278)

Para ordenar piezas con entrega a domicilio – 1-800-659-7084

For the location of a Sears Parts and Repair Center in your area:

Call 24 hours a day, 7 days a week

1-800-488-1222

**For information on purchasing a Sears Maintenance Agreement
or to inquire about an existing Agreement:**

Call 9 am – 5 pm, Monday – Saturday

1-800-827-6655



The Service Side of SearsSM

Free Manuals Download Website

<http://myh66.com>

<http://usermanuals.us>

<http://www.somanuals.com>

<http://www.4manuals.cc>

<http://www.manual-lib.com>

<http://www.404manual.com>

<http://www.luxmanual.com>

<http://aubethermostatmanual.com>

Golf course search by state

<http://golfingnear.com>

Email search by domain

<http://emailbydomain.com>

Auto manuals search

<http://auto.somanuals.com>

TV manuals search

<http://tv.somanuals.com>