

Operators Manual

CRAFTSMAN®

6 Horsepower
2250 PSI
2.5 GPM

HIGH PRESSURE WASHER CLEANING SYSTEM

Model No. 580.768030

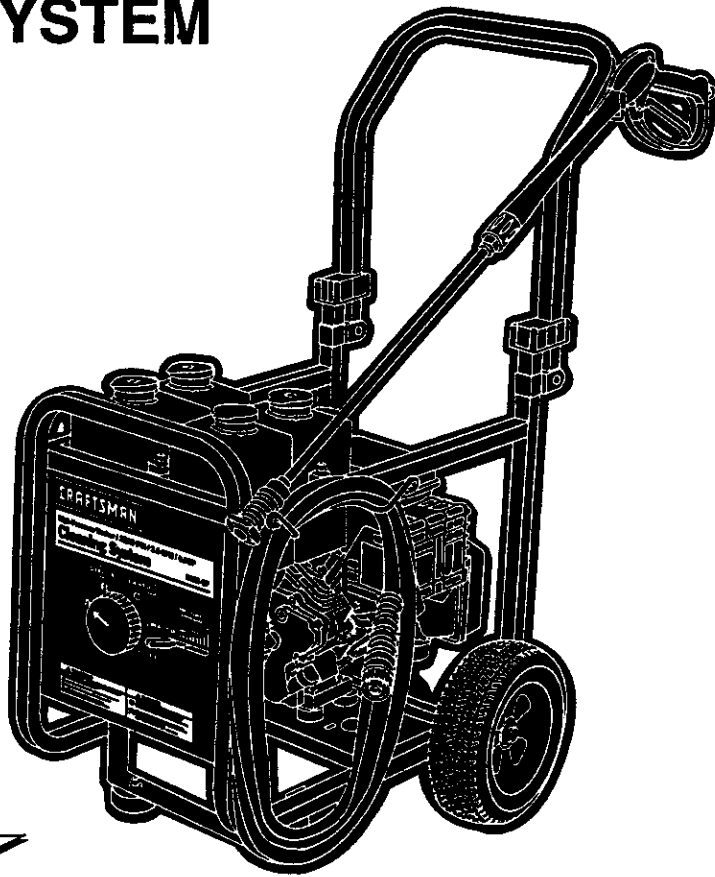

HOURS: Mon. - Fri. 8 a.m. to 5 p.m. (CT)

CAUTION:
Before using this product, read this manual and follow all its Safety Rules and Operating Instructions.

- Safety
- Assembly
- Operation
- Maintenance
- Parts

Sears, Roebuck and Co., Hoffman Estates, IL 60179

Visit our Craftsman website: www.sears.com/craftsman

TABLE OF CONTENTS

| | | | |
|-------------------------------|-------|---|-----------|
| Warranty | 2 | Troubleshooting | 15 |
| Safety Instructions | 2-3 | Replacement Parts | 17-25 |
| Assembly | 4 | Emission Control Warranty Statement | 26-27 |
| Operation | 5-9 | How to order parts and request service | Back page |
| Maintenance | 10-13 | | |
| Storage | 14 | | |

WARRANTY

LIMITED ONE YEAR WARRANTY ON CRAFTSMAN HIGH PRESSURE WASHER

For one year from the date of purchase, when this Craftsman Cleaning System is maintained and operated according to the instructions in the owner's manual, Sears will repair, free of charge, any defect in material and workmanship.

If this washer is used for commercial purposes, this warranty applies for only 90 days from the date of purchase. If this high pressure washer is used for rental purposes, this warranty applies for only 30 days after date of purchase.

This warranty does not cover:

- Expendable items such as spark plugs, air filters, or chemical solutions.
- Repairs necessary because of operator abuse or negligence, including damage resulting from no water being supplied to pump or failure to maintain the equipment according to the instructions contained in the owner's manual.

WARRANTY SERVICE IS AVAILABLE BY RETURNING THE HIGH PRESSURE WASHER TO THE NEAREST SEARS SERVICE CENTER OR DEALER IN THE UNITED STATES.

This warranty gives you specific legal rights and you may also have other rights, which vary from state to state.

Sears, Roebuck and Co., Dept. 817WA, Hoffman Estates, IL 60179

SAFETY INSTRUCTIONS



WARNING:



The engine exhaust from this product contains chemicals known to the State of California to cause cancer, birth defects, or other reproductive harm.



CAUTION: Before using this product, read this manual and follow all Safety Rules and Operating Instructions.



DANGER: When transporting, setting up, adjusting or making repairs to your cleaning system, **always** disconnect the spark plug wire and place it where it cannot contact the spark plug to prevent accidental starting.

- Engine exhaust gases contain **DEADLY** carbon monoxide gas. This dangerous gas, if breathed in sufficient concentrations, can cause unconsciousness or even death. Operate this equipment only in the open air where adequate ventilation is available.

- Gasoline is highly **FLAMMABLE** and its vapors are **EXPLOSIVE**. Do not permit smoking, open flames, sparks or heat in the vicinity while handling gasoline. Avoid spilling gasoline on a hot engine. Allow unit to cool for 2 minutes before refueling. Comply with all laws regulating storage and handling of gasoline.
- Locate this cleaning system in areas away from combustible materials, combustible fumes or dust.
- The high pressure equipment is designed to be used with Sears authorized parts only. If you use this equipment with parts that do not comply with minimum specifications, the user assumes all risks and liabilities.
- Some chemicals or detergents may be harmful if inhaled or ingested, causing severe nausea, fainting or poisoning. The harmful elements may cause property damage or severe injury.
- Do not allow **CHILDREN** to operate the cleaning system at any time.

- Operate engine only at governed speed. Running the engine at excessive speeds increases the hazard of personal injury. Do not tamper with parts which may increase or decrease the governed speed.
- Do not wear loose clothing, jewelry or anything that may be caught in the starter or other rotating parts.
- Before starting the cleaning system in cold weather, check all parts of the equipment and be sure ice has not formed there.
- Units with broken or missing parts, or without protective housing or covers should NEVER be operated.
- The muffler and air cleaner must be installed and in good condition before operating the cleaning system. These components act as spark arrestors if the engine backfires.
- Check the fuel system for leaks or signs of deterioration such as chafed or spongy hose, loose or missing clamps or damaged tank or cap. Correct all defects before operating the cleaning system.
- Do not spray flammable liquids.
- Never allow any part of the body to come in contact with the fluid stream. DO NOT come in contact with a fluid stream created by a leak in the high pressure hose.
- High pressure streams of fluid this equipment produces can pierce skin and its underlying tissues, leading to serious injury and possible amputation.
- Never aim the gun at people, animals or plants.
- High pressure spray can cause paint chips or other particles to become airborne and fly at high speeds.
- Always wear eye protection when you use this equipment or when you are in the vicinity where the equipment is in use.
- Operate the pressure at no more than the PSI fluid pressure rated for your cleaning system.
- Never move the machine by pulling on the high pressure hose. Use the handle provided on the top of the unit.
- Always be certain the spray gun, nozzles and accessories are correctly attached.
- Never use a spray gun which does not have a trigger lock or trigger guard in place and in working order.
- Use a respirator or mask whenever there is a chance that vapors may be inhaled. Read all instructions with the mask so you are certain the mask will provide the necessary protection against inhaling harmful vapors.
- High pressure spray may damage fragile items including glass. Do not point spray gun at glass when in the jet spray mode.
- Keep the hose connected to machine or the spray gun while the system is pressurized. Disconnecting the hose while the unit is pressurized is dangerous.
- Hold the spray gun firmly in your hand before you start the unit. Failure to do so could result in an injury from a whipping spray gun. Do not leave the spray gun unattended while the machine is running.
- The cleaning area should have adequate slopes and drainage to reduce the possibility of a fall due to slippery surfaces.
- Keep water spray away from electric wiring or fatal electric shock may result.
- Do not secure trigger gun in the pull-back (open) position.
- Do not by-pass any safety device on this machine.
- The muffler and engine heat up during operation and remain hot immediately after shutting it down. Avoid contact with a hot muffler or engine or you could be severely burned.
- Operate and store this unit on a stable surface.
- Always store cleaning system with the Dial-a-Cleaner™ knob in the OFF position.
- High pressure hose can develop leaks from wear, kinking, abuse, etc. Water spraying from a leak is capable of injecting material into skin. Inspect hose each time before using it. Check all hoses for cuts, leaks, abrasions or bulging of cover, or damage or movement of couplings. If any of these conditions exist, replace hose immediately. Never repair high pressure hose. Replace it with another hose that meets minimum pressure rating of your cleaning system.



LOOK FOR THIS SYMBOL TO POINT OUT IMPORTANT SAFETY PRECAUTIONS. IT MEANS "ATTENTION!!! BECOME ALERT!!! YOUR SAFETY IS INVOLVED."

ASSEMBLY

CARTON CONTENTS

The following parts are shipped loose with your cleaning system:

- Main Unit — pressure washer with wheels, chemical tanks, guide handle.
- High Pressure Hose (already attached to pump)
- Parts Box (which includes items listed below)
 - Spray Gun
 - Wand Extension with Hi/Lo Adjustable Nozzle
 - Engine Oil
 - Three-pack of chemical concentrates
- Manual Bag (which includes the items listed below)
 - Owner's Manual
 - Nozzle Cleaner Kit
 - "O"-Ring Kit
 - Tank Labels

Become familiar with each piece before assembling the cleaning system. Check all contents against the illustration on Page 5. If any parts are missing or damaged, call the Pressure Washer Helpline at 1-800-222-3136.

TO REMOVE PRESSURE WASHER FROM CARTON

- Remove loose parts and parts box included with your cleaning system.
- Slice two corners at guide handle end of carton from top to bottom so the panel can be folded down flat.

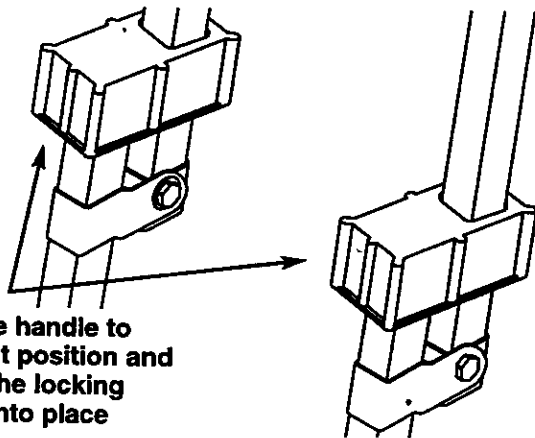

- Raise guide handle, secure in place.
- Roll the cleaning system out the open end of the carton.
- Check carton for additional loose parts.

HOW TO SET UP YOUR PRESSURE WASHER

For the most part, your Craftsman High Pressure Cleaning System has been assembled at the factory. You must, however, assemble the spray gun, and attach the high pressure hose to the spray gun.

- Cut the tie wraps on the high pressure hose and connect high pressure hose to gun. Tighten by hand.

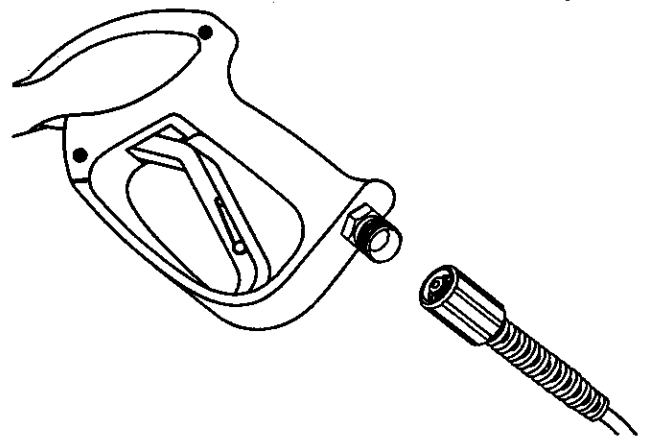

- Attach nozzle extension to spray gun.

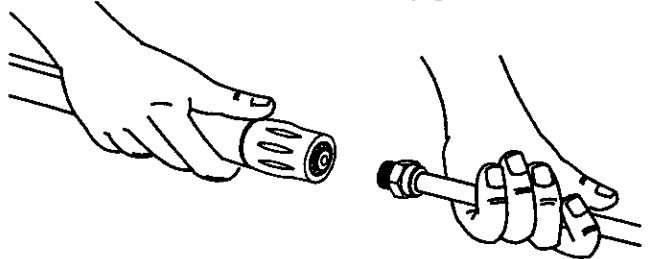

- Place assembled spray gun on holder.

OPERATION

KNOW YOUR HIGH PRESSURE WASHER

Read this owner's manual and safety rules before operating your cleaning system. Compare the illustrations with your cleaning system to familiarize yourself with the locations of various controls and adjustments.

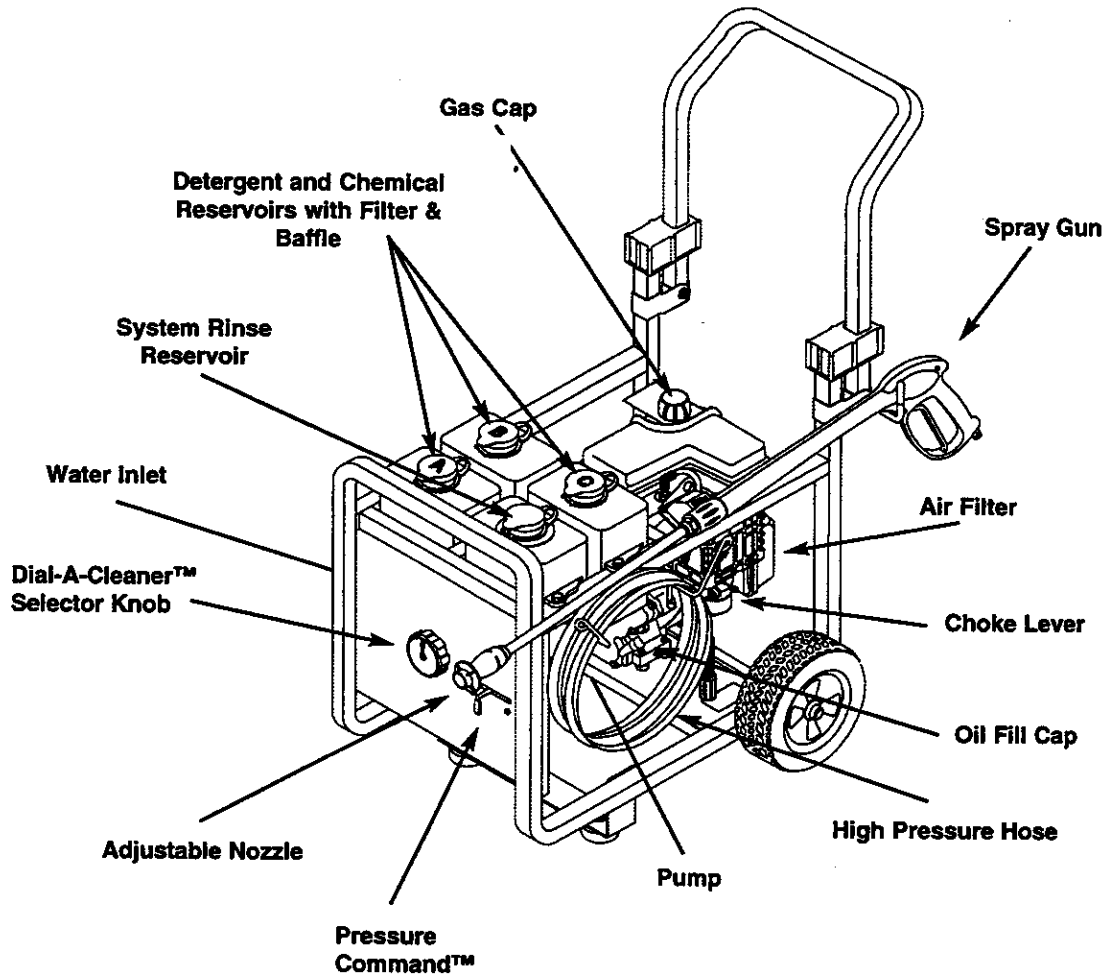

Adjustable Nozzle – Adjust for high or low pressure; narrow or fan spray.

Air Filter – Dry type filter element limits the amount of dirt and dust that gets in the engine.

Choke Lever – Used to start a cold engine.

Dial-A-Cleaner™ Selector Knob – Selects any one of three chemicals or selects the clean water system rinse.

Gas Cap – Fill engine with regular unleaded gasoline here.

High Pressure Hose – Connect one end to the spray gun.

Oil Fill Cap – Fill engine with oil here. See page 7 for oil recommendations.

Pressure Command™ – Sets output water pressure.

Pump – Develops high pressure water.

Spray Gun – Controls the application of water onto cleaning surface with trigger device. Includes safety latch.

System Rinse, Detergent and Chemical Reservoirs – Used to provide detergent or other chemicals to the low pressure water stream.

Water Inlet – Connection for garden hose.

HOW TO USE YOUR CLEANING SYSTEM

Read these instructions and learn how to use your cleaning system before you attempt to start your cleaning system. If you have any problems operating your cleaning system, please call the pressure washer helpline at 1-800-222-3136.

How To Use the Adjustable Nozzle

WARNING: Never adjust spray pattern when spraying. Never put hands in front of the nozzle when adjusting the spray.

- Push the nozzle forward for low pressure..Pull the nozzle backward until it “snaps” into place to achieve high pressure.

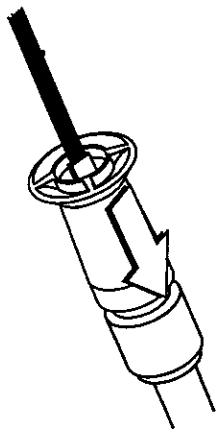

Pull nozzle backward for high pressure.

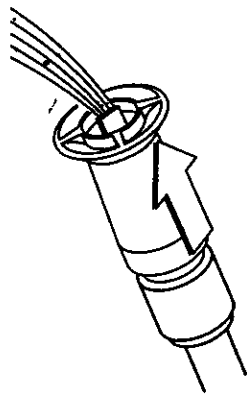

Push nozzle forward for low pressure.

- Twisting the nozzle adjusts the spray pattern from a narrow to a “fan” pattern.

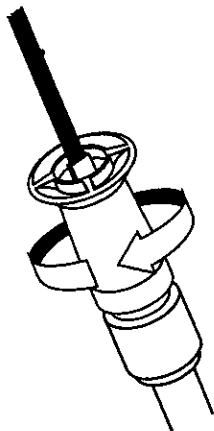

Twist nozzle clockwise for narrow spray.

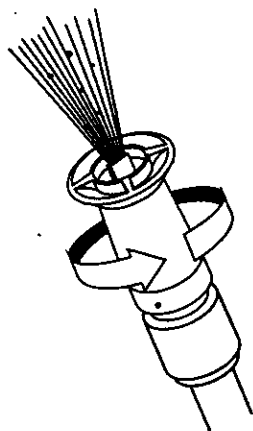

Twist nozzle counterclockwise for “fan” pattern.

- For most effective cleaning, keep spray nozzle between 8 to 24 inches away from cleaning surface.
- Damage to the surface may occur if you get spray nozzle too close to it.

Cleaning With The Adjustable Nozzle and Applying Chemical

IMPORTANT: Use soaps designed specifically for pressure washer cleaning systems. Household detergents could damage the pump.

IMPORTANT: You must attach all hoses before you start the engine. Starting the engine without all the hoses connected and without the water turned ON will damage the pump.

Up to three (3) different solutions can be carried on the cleaning system at one time. To apply detergent follow these steps:

- Dilution is necessary when using the supplied chemical packets. Simply snip one corner of the plastic pouch, pour the chemical into the tank, then fill the tank with clean water. Label tanks with the provided tank labels.

Pour chemical into one of the tanks labeled A, B, C.

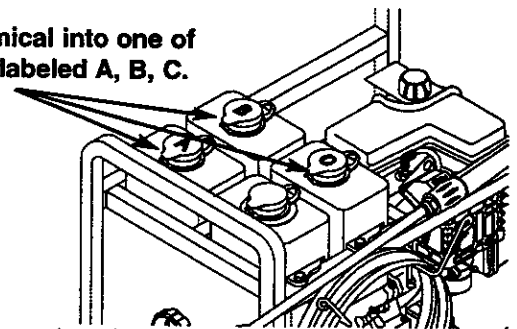

- If using another chemical designed for use with pressure washers, prepare the chemical solution as required by the chemical manufacturer. Fill chemical reservoir(s) with the prepared solution as needed.
- Rotate the Dial-A-Cleaner™ selector knob to the letter corresponding to the desired reservoir.
- Push the adjustable nozzle forward to low pressure mode. **Detergent cannot be applied with nozzle in high pressure position.**
- Review the use of the adjustable nozzle.
- Connect garden hose to water inlet , check that high pressure hose is connected to spray gun and pump (see ASSEMBLY on page 4), and start engine.

Connect garden hose here.

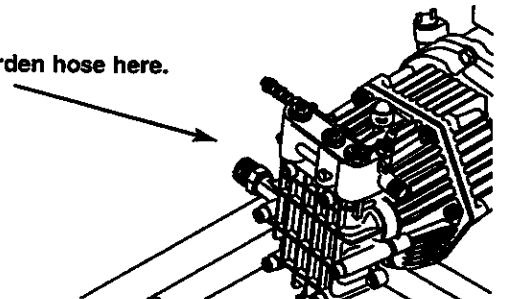

CAUTION: Before starting your Cleaning System, make sure you have read and followed the instructions in the sections “Before Starting the Cleaning System” on page 7 and “To Start the Cleaning System” on page 8.



Warning: Be extremely careful if you must use the cleaning system from a ladder, scaffolding or any other relatively unstable location. When you press the trigger, the recoil from the initial spray could force you to fall, or if you are too close to the cleaning surface, high pressure could force you off a climbing apparatus.

- Start at lower portion of area to be washed and work upward, using long, even overlapping strokes.
- Allow detergent to 'soak in' (between 3-5 minutes) before washing and rinsing. Reapply as needed to prevent surface from drying.

Wash and Rinse Surface

This Craftsman Cleaning System permits regulation of output water pressure by varying the engine speed. The Pressure Command™ found on the front panel may be set, as follows:

| | | | |
|--------------------|---------------------------|------------------------------|-----------------------------|
| Pressure | Low | to | High |
| Duty | Light | Medium | Heavy |
| Application | Auto Boat Furniture | Concrete Driveway Deck | Paint removal Degreasing |

After you have applied detergent, scour the surface with the high pressure water stream and then rinse it clean, as follows:

- Pull adjustable nozzle backward until it snaps to get high pressure mode. Chemical will not flow when in the high pressure mode.
- Adjust Pressure Command™ control to obtain desired water pressure.
- Expand the spray pattern for a more gentle rinsing action. Start at top of area to be rinsed, working down with same action as for cleaning.



CAUTION: Test a small area of the surface to be cleaned. Make sure there is no damage caused by the high pressure spray.

RINSE SYSTEM AFTER EVERY USE

It is imperative that the chemical selector system be rinsed after each use to prevent clogging or leaks:

- Fill the System Rinse reservoir with clean water.
- Before disconnecting the water supply, start your cleaning system.



CAUTION: Before starting your Cleaning System, make sure you have read and followed the instructions in the sections "Before Starting the Cleaning System" on page 7 and "To Start the Cleaning System" on page 8.

- Push adjustable nozzle forward to get low pressure mode.

- Rotate the Dial-A-Cleaner™ selector knob to the letter corresponding to the System Rinse tank. As clean rinse water is drawn through the system, continue the flow until no detergent foam is observed.
- Rotate the Dial-A-Cleaner™ selector knob to the OFF position.

BEFORE STARTING THE CLEANING SYSTEM

To operate the engine you will need to do the following:

Add Engine Oil

Only use high quality detergent oil rated with API service classification SF or SG. Select the oil's SAE viscosity grade according to your expected operating temperature:

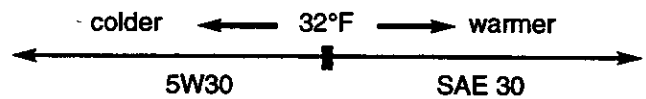

Although multi-viscosity oils (5W30, 10W30, etc.) improve starting in cold weather, these multi-viscosity oils will result in increased oil consumption when used above 32°F. Check your engine oil level more frequently to avoid possible damage from running low on oil.

- Place pressure washer system on a level surface
- Clean area around oil fill and remove oil dipstick.
- Pour oil from enclosed bottle into the oil fill opening until oil reaches the full mark on the oil dipstick. Stop and check the oil level periodically. Do not overfill.
- Install oil dipstick, hand tighten securely.

Add Gasoline

- Use regular unleaded gasoline with the cleaning system engine. Fuel tank capacity is 3 U.S. quarts.



DANGER: Never fill fuel tank indoors. Never fill fuel tank when engine is running or hot. Do not smoke when filling fuel tank.



CAUTION: Do not overfill the fuel tank. Always leave room for expansion.



CAUTION: Experience indicates that alcohol blended fuels (called gasohol or using ethanol or methanol) can attract moisture which leads to separation and formation of acids during storage. Acidic gas can damage the fuel system of an engine while in storage.

To add fuel to engine:

- Clean area around fuel cap, remove cap.
- Add **regular unleaded** gasoline, slowly, to the fuel tank.

Important: Never mix oil with gasoline.

- Install fuel cap and wipe up any spilled gasoline.

TO START THE CLEANING SYSTEM

The best way to start your cleaning system engine for the first time is to follow these instructions step-by-step. This starting information also applies whenever you start the engine after you have let the cleaning system sit idle for at least a day.

- Place the cleaning system in an area close enough to an outside water source that can flow at a rate of at least 3 gallons per minute. Connect a garden hose to the water spout.
- Check that the high pressure hose is tightly connected to the spray gun and to the pump. See ASSEMBLY section on page 4.
- Check inlet screen on the water inlet. If the screen is dirty, clean before attaching a garden hose. If the screen is damaged, **do not** connect to the garden hose. Replace with screen provided in maintenance kit or call 1-800-366-PART to order a replacement inlet screen.
- Attach the the garden hose to the water inlet.
- **Turn on the water.**

Important: Do not run pump without the water supply connected and turned on. You must follow this caution or the pump will be damaged.

- Remove the adjustable nozzle extension from the spray gun.
- Pull the trigger on the spray gun and hold until a steady stream of water appears.
- Engage the safety latch on the spray gun.

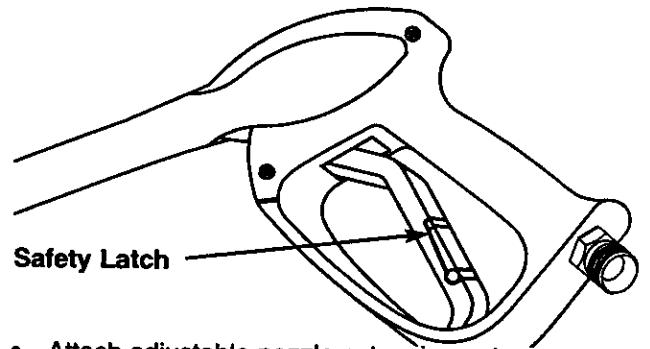

- Attach adjustable nozzle extension onto spray gun.
- Pull choke lever all the way out to the "FULL CHOKE POSITION."

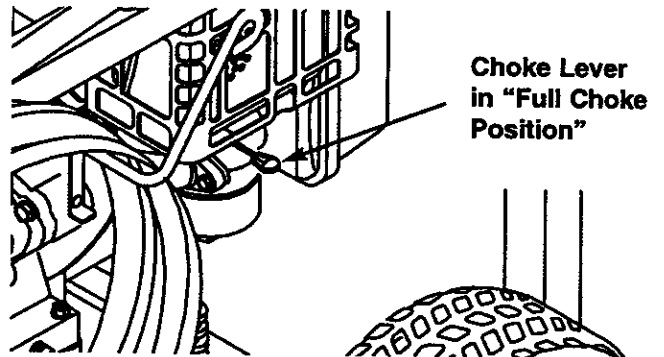

Note: If restarting a warm engine after a short shutdown, move choke lever to "NO CHOKE POSITION."

- Move Run/Stop switch to the "I" or on position.

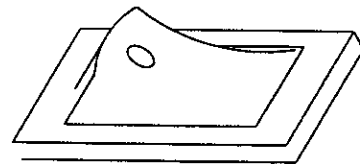

- Grasp starter handle and pull slowly until you feel some resistance. Then pull cord rapidly to overcome compression, prevent kickback and start the engine. Let rope return to starter **slowly**.

Note: The Pressure Command™ may be placed in any position during starting or operation.

- When engine starts, move choke lever to “1/2 CHOKE” until engine runs smoothly and then to “NO CHOKE POSITION.” If engine falters, move choke lever to “1/2 CHOKE” until engine runs smoothly and then to “NO CHOKE POSITION.”

Note: If the engine fails to start after 3 pulls, move choke lever to “NO CHOKE POSITION” and pull starter rope again.

Note: If engine fires, but does not continue to run, move choke lever to “FULL CHOKE” and repeat starting instructions.

- Once the engine has started, disengage the spray gun safety latch.

HOW TO STOP YOUR PRESSURE WASHER

Important: Do not run pump without the water supply connected and turned on. You must follow this caution or the pump will be damaged.

- Move the Run/Stop switch to the “0” or OFF position.
- **Simply shutting off the engine will not release pressure in the system.** Squeeze trigger on the spray gun to relieve pressure in the hose.

Note: A small amount of water will squirt out when you release the pressure.

- **Rotate the Dial-A-Cleaner™ selector knob to the OFF position to prevent chemical leakage.**

SIPHONING

We recommend that you **DO NOT** siphon standing water for your water supply. Contaminated, brackish or dirty water can damage the pump. Connect only to household water supply.

TIPS

- Never use the garden hose inlet to siphon detergent or wax.
- If you hold the spray nozzle too far away from the object being cleaned, washing will not be as effective.
- **Always** store the cleaning system with the Dial-A-Cleaner™ selector knob at the OFF position.

MAINTENANCE

CUSTOMER RESPONSIBILITIES

| MAINTENANCE SCHEDULE FILL IN DATES AS YOU COMPLETE REGULAR SERVICE | HOURLY OPERATING INTERVAL | | | SERVICE DATES | | | |
|--|---|--------------------------------|---------------------------------|---------------|--|--|--|
| | Before Each Use | Every 50 Hours or Yearly | Every 100 Hours or Yearly | | | | |
| MAINTENANCE TASK | | | | | | | |
| PRESSURE WASHER | | | | | | | |
| Check/clean water inlet screen on quick-connect. | X† | | | | | | |
| Check high pressure hose. | X | | | | | | |
| Check detergent hose. | X | | | | | | |
| Check spray gun and assembly for leaks. | X | | | | | | |
| Purge pump of air and contaminants. | X | | | | | | |
| ENGINE | | | | | | | |
| Check oil level. | X | | | | | | |
| Change engine oil. | | X* | | | | | |
| Service air cleaner. | | | X** | | | | |
| Clean/replace spark plug. | | | X | | | | |
| Prepare for storage. | Prepare unit for storage if it is to remain idle for longer than 30 days. | | | | | | |

† Clean if clogged. Replace if perforated or torn.

* Change oil after the first (2) operating hours and every 50 hours thereafter. Change sooner when operating under dirty or dusty conditions.

** Replace more often under dirty or dusty conditions.

PRODUCT SPECIFICATIONS

Pressure Washer Specifications

| | |
|--------------------------|---------------------|
| PRESSURE | 2250 psi |
| FLOW RATE | 2.5 GPM |
| CHEMICAL MIX | Use as directed |
| WATER SUPPLY TEMPERATURE | Not to Exceed 140°F |

Engine Specifications

| | |
|------------------------------|--|
| ENGINE MODEL | Tecumseh |
| RATED HORSEPOWER | 6 |
| SPARK PLUG: Type: | Champion RN4C or equivalent. Set Gap to: 0.030 inch (0.76mm) |
| GASOLINE CAPACITY | 3 U.S. quarts |
| OIL | SAE 30 weight |
| SOLID STATE IGNITION AIR GAP | 0.0125 inch |

In the State of California a spark arrestor is required by law (Section 4442 of the California Public Resources Code). Other states may have similar laws. Federal laws apply on federal lands.

Note: If you equip the engine of your cleaning system with a spark arrestor muffler, the spark arrestor must be maintained in effective working order by the owner/operator.

You can order a spark arrestor (P/N 36085) through your Sears Service Center.

GENERAL RECOMMENDATIONS

The warranty of the cleaning system does not cover items that have been subjected to operator abuse or negligence. To receive full value from the warranty, operator must maintain cleaning system as instructed in this manual.

Some adjustments will need to be made periodically to properly maintain your cleaning system.

All adjustments in the Service and Adjustments section of this manual should be made at least once each season.

- Once a year you should clean or replace the spark plug and replace the air filter and check the gun and wand assembly for wear. A clean spark plug and new air filter assure proper fuel-air mixture and help your engine run better and last longer.

BEFORE EACH USE

- Check water inlet screen for damage.
- Check high pressure hose for leaks.
- Check chemical tanks and filters for damage.
- Check gun and wand assembly for leaks.
- Purge pump of air and contaminants.
- Check engine oil level.

PRESSURE WASHER MAINTENANCE

Check and Clean Inlet Screen

Examine garden hose inlet screen. Clean if it is, clogged or replace if it is torn.

Check High Pressure Hose

High pressure hose can develop leaks from wear, kinking, or abuse. Inspect hose each time before using it. Check for cuts, leaks, abrasions, bulging of cover, or damage or movement of couplings. If any of these conditions exist, replace hose immediately.



DANGER: Never repair a high pressure hose. Replace with hose with one that meets the minimum pressure rating of the system.

Check Chemical Reservoirs

Tank covers should snap cleanly onto tank. Ensure chemical labels correctly identify tank contents. Ensure that the System Rinse tank is filled with clean water. Ensure that Dial-A-Cleaner™ selector knob rotates freely between each position. Examine the tanks and replace if the filter is clogged

Check Gun and Wand

Examine hose connection to gun and make sure it is secure. Test trigger by pressing it and making sure it springs back into place when you release it. Put safety latch in UP position and test trigger. You should not be able to press trigger. Replace gun immediately if it fails any of these tests.

Check In-Line Filter

Refer to the illustration and service the in-line filter if it becomes clogged, as follows:

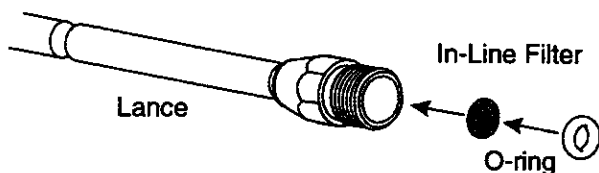

1. Detach gun and lance from high pressure hose. Detach lance from gun and remove o-ring and screen from lance. Flush the screen, gun, and lance with clean water to clear debris.

2. If the screen is damaged, the o-ring kit contains a replacement in-line filter screen and an o-ring. If undamaged, reuse screen.
3. Place the in-line filter screen into the threaded end of the lance. Direction does not matter. Push the screen in with the eraser end of a pencil until it rests flat at the bottom of the opening. Take care to not bend the screen.
4. Place the o-ring into the recess. Push the o-ring snugly against the in-line filter screen.
5. Assemble the lance to the spray gun, as described earlier in this manual.

Purge Pump of Air and Contaminants

To remove the air from the pump, follow these steps:

- Set up the cleaning system as described in the ASSEMBLY section and connect the water supply.
- Remove the wand extension from the gun.
- Pull the trigger on the gun and hold until a steady stream of water appears.

To remove the contaminants from the pump, follow these steps:

- Set up the cleaning system as described in the ASSEMBLY section, and connect the water supply.
- Remove the nozzle attachment from the gun.
- Start the engine according to instructions in OPERATION section.
- Pull the trigger on the gun and hold.
- When the water supply is steady and constant, engage the safety latch and refasten the nozzle attachment.

Nozzle Maintenance

If the nozzle becomes restricted or clogged with foreign materials, such as dirt, excessive pump pressure may develop. A partially clogged nozzle can cause a pulsing condition during use. This generally is not a pump related problem, but rather a clogged or partially restricted nozzle.

If the nozzle becomes clogged or partially restricted, immediately clean the nozzle with the kit included with your cleaning system by following these instructions:

- Shut off the engine and turn off the water supply.
- Separate the wand from the gun.
- Rotate to stream setting.
- Remove nozzle from the end of the wand using a 2mm or 5/64 allen wrench.

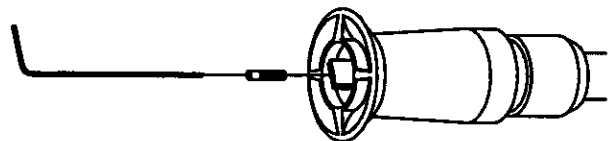

- Use the wire included in the kit or a small paper clip to free the foreign materials clogging or restricting the nozzle.

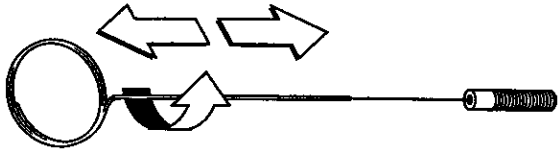

Insert wire into nozzle and turn back and forth to clear obstruction.

- Remove additional debris by back flushing water supply through wand. Back flush between 30 to 60 seconds. Turn wand to stream spray and move nozzle from low to high pressure while flushing.

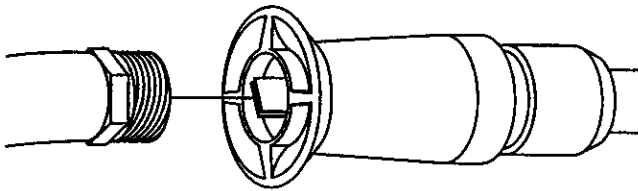

- Reinstall nozzle into wand. DO NOT overtighten.
- Reconnect wand extension to spray gun.
- Reconnect the water supply, turn ON the water, and start the engine.
- Test the cleaning system by operating with nozzle in the high and the low pressure positions.

O-Ring Maintenance

Through the normal operation of your cleaning system, the o-rings keep the connections of the hoses and gun tight and leak-free. They may become worn or damaged with use. Provided with your cleaning system is an O-ring Maintenance Kit containing replacement o-rings, a rubber washer and a garden hose inlet screen.

Parts in the O-Ring Kit Include:

- 1 O-ring, red, (p/n B2726) for the end of the spray gun connection between gun and high/low spray wand.

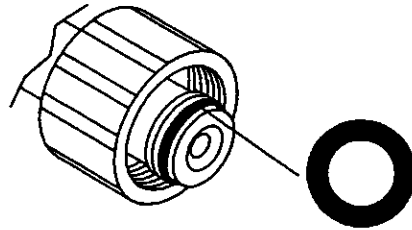

- 2 O-rings, yellow, (p/n B2264) for the ends of the high pressure hose.

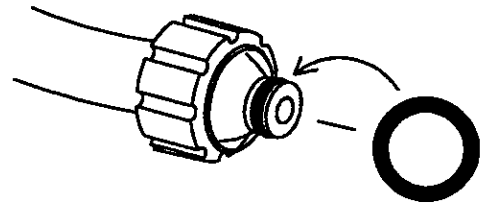

Note: The above two o-rings are close in size. Please match carefully to assure proper o-ring usage.

- 1 rubber washer (p/n B2385) for the inside of the garden hose connector.
- 1 water inlet screen (p/n B2384) for the garden hose connector.

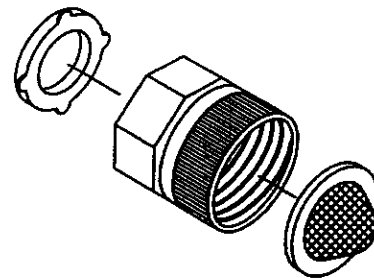

To remove a worn or damaged O-Ring:

- Use a small flathead screwdriver to get underneath the o-ring and pry it off.

ENGINE MAINTENANCE

Maintenance, replacement or repair of the emission control devices and systems may be performed by any non-road engine repair establishment or individual.

Checking Oil Level

Oil level should be checked prior to each use or at least every 5 hours of operation. Keep oil level maintained.

Changing Oil

Change engine oil after the first two hours and every 50 hours thereafter. If you are using your cleaning system under extremely dirty or dusty conditions, or in extremely hot weather, change oil more often.

Change oil while engine is still warm from running, as follows:

- Place a suitable container for draining oil beneath the engine.
- Clean area around oil drain plug, remove plug and drain oil completely. When crankcase is empty, reinstall oil drain plug.

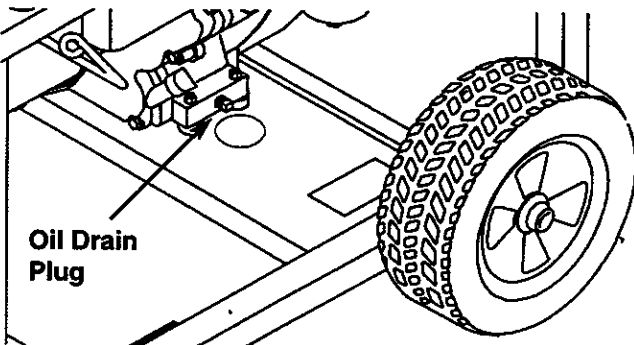

- Clean area around oil fill plug and remove the oil dipstick. Fill engine crankcase with recommended oil until oil level is at the full mark on the dipstick. **POUR SLOWLY.**
- When engine crankcase is filled to proper level, install and tighten oil dipstick.

Service Air Cleaner

Your engine will not run properly and may be damaged if you run it with a dirty air cleaner.

Replace the air cleaner once every 100 hours of operation or once each year, whichever comes first. Replace more often if operating under dirty or dusty conditions. Do not attempt to clean or oil filter. Replacements are available at your local Sears Authorized Service Center.

To clean or replace the air cleaner, follow these steps:

- Remove wing nut on the air cleaner cover.

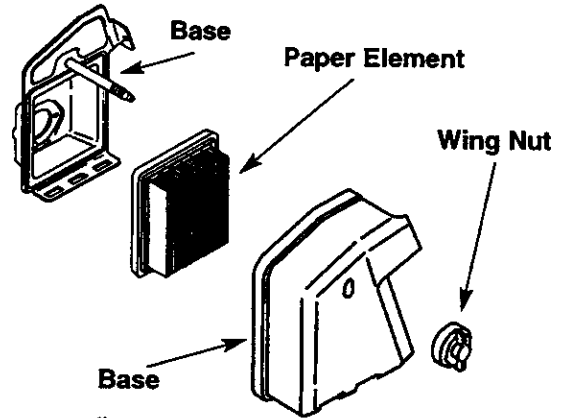

- Remove dirty paper element carefully to prevent debris from falling into carburetor. Discard.
- Clean inside of filter case.
- Install new paper air filter.
- Reassemble all parts and fasten securely to the carburetor with the wing nut.

Clean / Replace Spark Plug

Clean or replace the spark plug yearly or every 100 hours of operation.

CAUTION: Disconnect spark plug wire from spark plug and keep wire away from spark plug.

- Clean area around spark plug.
- Remove and inspect spark plug.
- Replace spark plug if the electrodes are pitted, burned or porcelain is cracked. For replacement use Champion RN4C or equivalent.
- Check electrode gap with wire feeler gauge and set gap at .030 inches, if necessary.

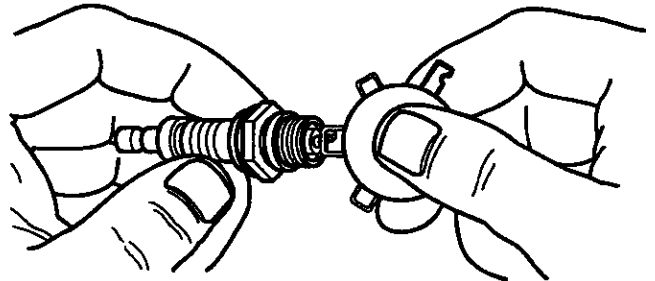

- Install spark plug, tighten securely.

Carburetor

If you think your carburetor needs adjusting, see your nearest Sears Service Center. Engine performance may be affected at altitudes above 4000 feet. For operation at higher elevations, contact your nearest Sears Service Center.

STORAGE

AFTER EACH USE

Water should not remain in the unit for long periods of time. Sediments of minerals can deposit on pump parts and “freeze” pump action. Follow these procedures after every use:

- Flush the chemical system by selecting the System Rinse tank and run the Pressure Washer with nozzle in low pressure mode. Flush for one minute or until the chemical is cleared from the system.
- Shut off the engine and let it cool, then remove all hoses.



CAUTION: Be sure the engine Run/Stop switch is in the '0' or OFF position before you continue.

- Empty the pump of all pumped liquids by pulling recoil handle about 6 times with the Run/Stop switch in the '0' or OFF position. This should remove most of the liquid in the pump.
- Rotate the Dial-A-Cleaner™ selector knob to the OFF position.
- Coil the high pressure hose and inspect it for damage. Cuts in the hose or fraying could result in leaks and loss of pressure. Should any damage be found, replace the hose. DO NOT attempt to repair a damaged hose. Replace the hose with the genuine Craftsman part.
- Drain water from hose and properly hang it on the wire support provided.
- Store system in a clean, dry area.



DANGER: Never store the engine with fuel in the gas tank indoors or in enclosed, poorly ventilated areas where fumes may reach an open flame, a spark, or pilot light.

WINTER STORAGE



CAUTION: You must protect your unit from freezing temperatures. Failure to do so will permanently damage your pump and render your unit inoperable.

To protect the unit from freezing temperatures:

- Empty all chemical reservoirs as follows:
 - a. Disconnect hose connected to chemical inject fitting on the pump. Place end of hose into suitable container.
 - b. Move the selector knob to Tank A and open that tank's cover. Gravity should shortly empty the tank contents into the container.
 - c. When the tank is empty, repeat step (b) for tanks B and C.
 - d. Reconnect the hose to the chemical inject fitting on the pump. Add 0.5 liter of clean fresh water to each tank and close tank's covers.

- Flush the chemical system by selecting a tank and run the Pressure Washer with nozzle in low pressure mode. Flush until each tank is empty, then switch the selector knob to the next tank. The last tank to be emptied must be the System Rinse tank.
- Connect a 3-foot section of garden hose to the inlet adapter. Pour RV-Antifreeze (antifreeze without alcohol) into the hose. Pull the recoil handle twice.

LONG TERM STORAGE

If you do not plan to use the Pressure Washer for more than 30 days, you must prepare the engine for long term storage.

It is important to prevent gum deposits from forming in essential fuel system parts such as the carburetor, fuel filter, fuel hose or tank during storage. Also, experience indicates that alcohol-blended fuels (called gasohol, ethanol or methanol) can attract moisture which leads to separation and formation of acids during storage. Acidic gas can damage the fuel system of an engine while in storage.

Protect Fuel System



DANGER: Drain fuel into approved container outdoors, away from open flame. Be sure engine is cool. Do not smoke.

- Remove all gasoline from the fuel tank to prevent gum deposits from forming on these parts and causing possible malfunction of engine.
- Run engine until engine stops from lack of fuel. Make sure you have water supply to pump inlet connected and turned ON.

Change Oil

While engine is still warm, drain oil from crankcase. Refill with recommended grade. (See Changing Oil)

Oil Cylinder Bore

- Remove spark plug. Squirt about 1 ounce (30 ml) of engine oil into the cylinder. Cover spark plug hole with rag. Crank engine slowly to distribute oil.



CAUTION: Avoid spray from spark plug hole when cranking engine.

- Install spark plug. Do not connect spark plug wire.

OTHER

- Do not store gasoline from one season to another.
- If possible, store your unit indoors and cover it to give protection from dust and dirt. **BE SURE TO EMPTY THE FUEL TANK.**

IMPORTANT: NEVER cover your cleaning system while engine and exhaust area are warm.

TROUBLESHOOTING

| PROBLEM | CAUSE | CORRECTION |
|---|---|--|
| <p>Pump has following problems: failure to produce pressure, or erratic pressure, chattering, loss of pressure, low water volume.</p> | <ol style="list-style-type: none"> 1. Nozzle in low pressure mode. 2. Water inlet is blocked. 3. Inadequate water supply 4. Inlet hose is kinked or leaking 5. Clogged water inlet screen. 6. Water supply is over 140°F. 7. Outlet hose is blocked. 8. Outlet hose leaks. 9. Gun leaks. 10. Nozzle is obstructed. 11. Pump is faulty. | <ol style="list-style-type: none"> 1. Pull nozzle backward for high pressure mode. 2. Clear inlet 3. Provide adequate water flow at least 3 gpm. 4. Straighten inlet hose, patch leak. 5. Replace / clean water inlet screen. 6. Provide cooler water supply. 7. Clear blocks in outlet hose. 8. Replace outlet hose if leaking. 9. Replace O-ring or gun if necessary. 10. Clear nozzle. 11. Contact Sears Service Department. |
| <p>Detergent fails to mix.</p> | <ol style="list-style-type: none"> 1. Detergent line is collapsed or kinked 2. Chemical tank filter is clogged. 3. Nozzle is in high pressure mode. 4. Dial-a-Cleaner knob is in off position. | <ol style="list-style-type: none"> 1. Repair or replace detergent line. 2. Replace tank 3. Push nozzle forward for low pressure mode. 4. Rotate knob for desired chemical. |
| <p>Engine runs good when not spraying but dies when you begin to spray.</p> | <p>Engine speed is too slow.</p> | <p>Contact Sears Service Department.</p> |
| <p>Engine will not start; or starts and runs rough</p> | <ol style="list-style-type: none"> 1. Dirty air cleaner 2. Out of gasoline. 3. Stale gasoline. 4. Spark plug wire not connected to spark plug. 5. Bad spark plug. 6. Water in gasoline. 7. Overchoking or flooded 8. Excessively rich fuel mixture. 9. Intake valve stuck open or closed. 10. Engine has lost compression. | <ol style="list-style-type: none"> 1. Clean or replace air cleaner. 2. Fill fuel tank. 3. Drain gas tank; fill with fresh fuel. 4. Connect wire to spark plug. 5. Replace spark plug. 6. Drain gas tank; fill with fresh fuel. 7. Set engine throttle control lever to fast position, choke in run position. 8. Contact Sears Service Department. 9. Contact Sears Service Department. 10. Contact Sears Service Department. |
| <p>Engine shuts down during operation</p> | <ol style="list-style-type: none"> 1. Out of gasoline. 2. Air filter dirty | <ol style="list-style-type: none"> 1. Fill fuel tank. 2. Replace Air filter. |
| <p>Engine lacks power.</p> | <p>Dirty air filter.</p> | <p>Replace air filter.</p> |

NOTES

REPLACEMENT PARTS

Tecumseh 6HP Enduro, Model #143.996005

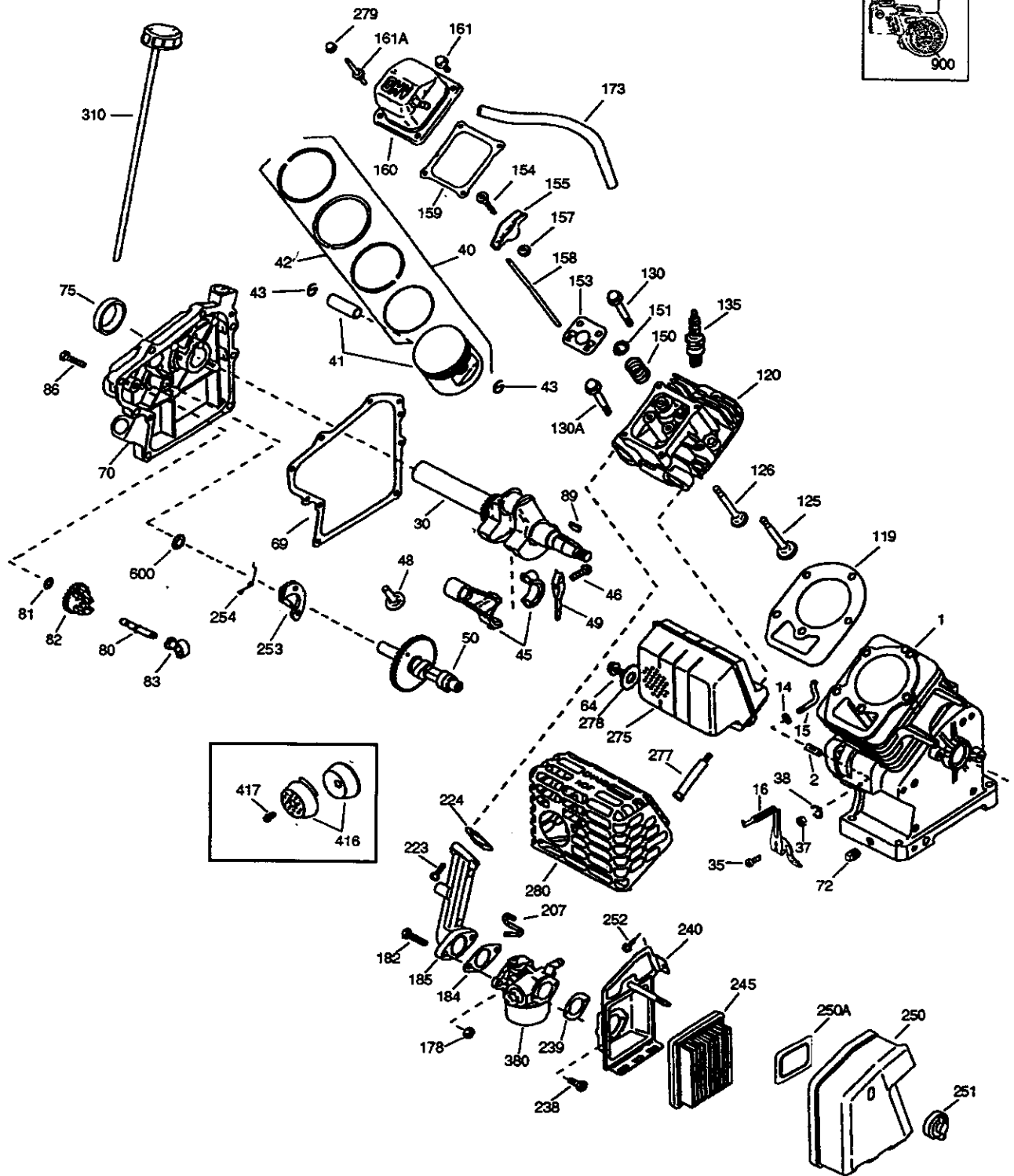
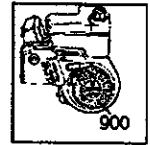

Tecumseh 6HP Enduro, Model #143.996005

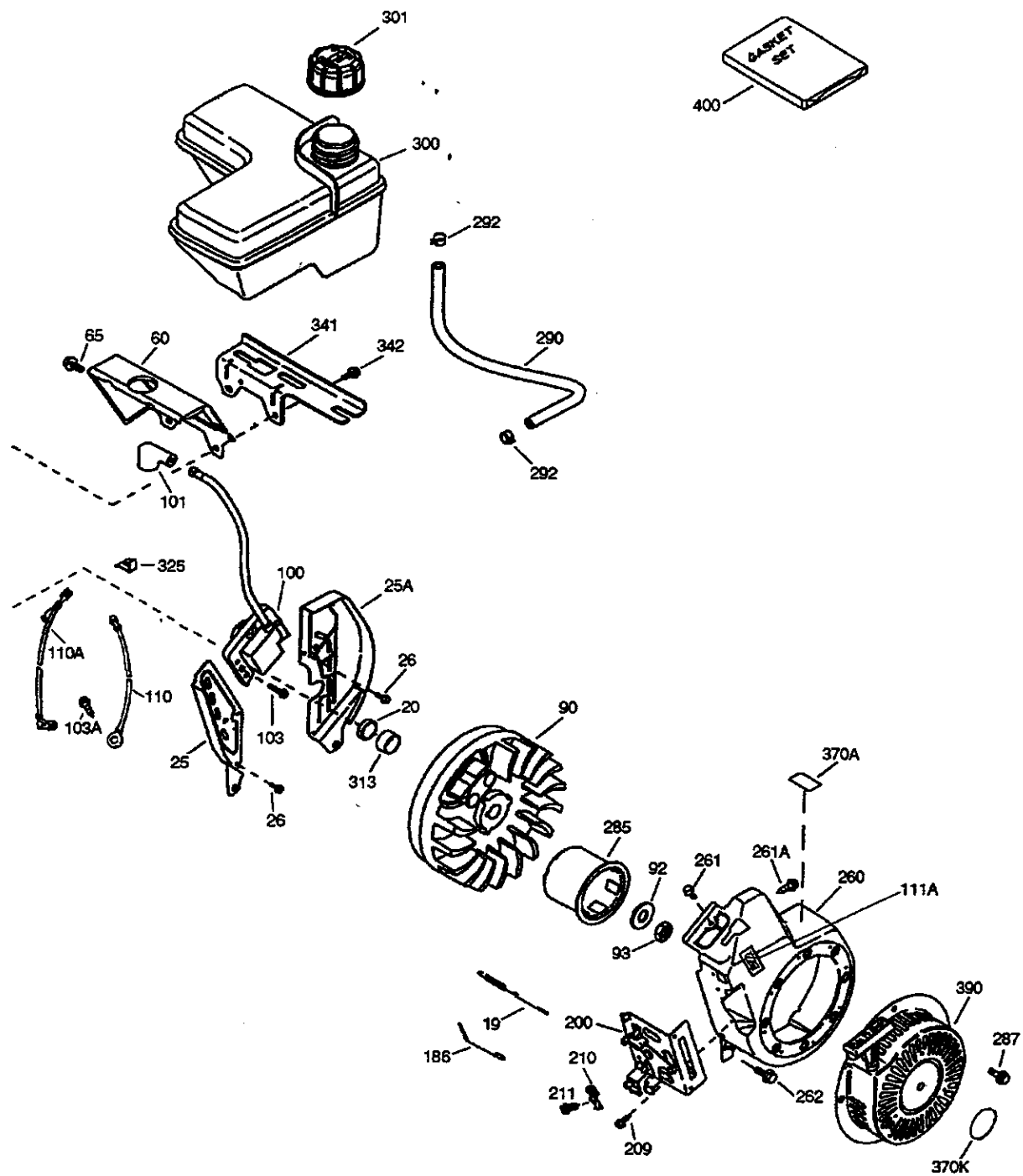

Tecumseh 6HP Enduro, Model #143.996005

| Item | Part # | Description | Qty. | Item | Part # | Description | Qty. |
|------|--------|--|------|------|--------|--|------|
| 1 | 37120A | Cylinder (Incl. 2, 20 & 72) | 1 | 153 | 36649 | Push Rod Guide | 1 |
| 2 | 26727 | Dowel Pin | 2 | 154 | 650913 | Rocker Arm Stud | 2 |
| 14 | 651052 | Washer | 1 | 155 | 35624A | Rocker Arm | 2 |
| 15 | 37108 | Governor Rod | 1 | 157 | 650914 | Nut, 1/4-28 | 2 |
| 16 | 37110 | Governor Lever | 1 | 158 | 36629 | Push Rod | 2 |
| 19 | 37111 | Extension Spring | 1 | 159 | 35626 | Rocker Arm Cover Gasket | 1 |
| 20 | 32600 | Oil Seal | 1 | 160 | 36630A | Rocker Arm Cover | 1 |
| 25 | 36621 | Air Baffle (Left) | 1 | 161 | 651008 | Screw, 1/4-20 x 31/64" | 2 |
| 25A | 36622 | Air Baffle (Right) | 1 | 161A | 651012 | Stud | 2 |
| 26 | 30200 | Screw, 10-24 x 9/16" | 1 | 173 | 36675A | Breather Tube | 1 |
| 30 | 34740 | Crankshaft | 1 | 178 | 650852 | Nut, 1/4-20 | 2 |
| 35 | 651053 | Screw, Torx T-25, 10-32 x 63/64" | 1 | 182 | 650451 | Screw, 1/4-20 x 1" | 2 |
| 37 | 29216 | Lock Nut, 10-32 | 1 | 184 | 26756 | Carburetor To Intake Pipe Gasket | 1 |
| 38 | 37109 | Retaining Ring | 1 | 185 | 36631 | Intake Pipe | 1 |
| 40 | 40004 | Piston, Pin & Ring Set (Std.) | 1 | 186 | 36711 | Governor Link | 1 |
| 40 | 40005 | Piston, Pin & Ring Set (.010" OS) | 1 | 200 | 36736 | Control Bracket (Incl. 210 & 211) | 1 |
| 41 | 36070 | Piston & Pin Ass'y (Std.) (Incl. 43) | 1 | 207 | 36632 | Throttle Link | 1 |
| 41 | 36071 | Piston & Pin Ass'y (.010" OS) (Incl. 43) | 1 | 209 | 650821 | Screw, 10-32 x 1/2" | 2 |
| | | Ring Set (Std.) | 1 | 210 | 27793 | Conduit Clip | 1 |
| 42 | 40006 | Ring Set (Std.) | 1 | 211 | 28942 | Screw, 10-32 x 3/8" | 1 |
| 42 | 40007 | Ring Set (.010" OS) | 1 | 223 | 650451 | Screw, 1/4-20 x 1" | 2 |
| 43 | 20381 | Piston Pin Retaining Ring | 2 | 224 | 36581 | Intake Pipe Gasket | 1 |
| 45 | 32875A | Connecting Rod Ass'y (Incl. 46 & 49) | 1 | 238 | 28820 | Screw, 10-32 x 1/2" | 2 |
| | | Connecting Rod Bolt | 2 | 239 | 27272A | Air Cleaner Gasket | 1 |
| 46 | 32610A | Connecting Rod Bolt | 2 | 240 | 36633A | Air Cleaner Body (Incl. 239) | 1 |
| 48 | 35616 | Valve Lifter | 2 | 245 | 36046 | Air Cleaner Filter | 1 |
| 49 | 36611 | Oil Dipper | 1 | 250 | 37073 | Air Cleaner Cover | 1 |
| 50 | 37040 | Camshaft (Incl. 253 & 254) | 1 | 250A | 37074 | Air Cleaner Baffle | 1 |
| 60 | 36623A | Blower Housing Extension | 1 | 251 | 650886 | Wing Nut | 1 |
| 64 | 651015 | Screw, 1/4-20 x 1-1/8" | 1 | 252 | 650821 | Screw, 10-32 x 1/2" | 1 |
| 65 | 30200 | Screw, 10-24 x 9/16" | 1 | 253 | 36701 | Compression Release Weight | 1 |
| 69 | 36624 | Cylinder Cover Gasket | 1 | 254 | 36702 | Compression Release Spring | 1 |
| 70 | 36766 | Cylinder Cover (Incl. 75 thru 83) | 1 | 260 | 36864 | Blower Housing | 1 |
| 72 | 27642 | Oil Drain Plug | 2 | 261 | 651008 | Screw, 1/4-20 x 31/64" | 1 |
| 75 | 36742 | Oil Seal | 1 | 261A | 650821 | Screw, 10-32 x 1/2" | 2 |
| 80 | 30574A | Governor Shaft | 1 | 262 | 651008 | Screw, 1/4-20 x 31/64" | 2 |
| 81 | 30590A | Washer | 1 | 275 | 36722 | Muffler | 1 |
| 82 | 30591 | Governor Gear Ass'y (Incl. 81) | 1 | 277 | 650988 | Screw, 1/4-20 x 2-9/32" | 2 |
| 83 | 36057 | Governor Spool | 1 | 278 | 36674 | Spacer | 1 |
| 86 | 650488 | Screw, 1/4-20 x 1-1/4" | 8 | 279 | 650852 | Nut & Lock Washer | 1 |
| 89 | 610961 | Flywheel Key | 1 | 280 | 36893 | Heat Shield | 1 |
| 90 | 611205 | Flywheel | 1 | 285 | 35985B | Starter Cup | 1 |
| 92 | 650815 | Belleville Washer | 1 | 287 | 0 | Rivet (Can be purchased locally) | 4 |
| 93 | 650816 | Flywheel Nut | 1 | 290 | 30705 | Fuel Line | 1 |
| 100 | 34443B | Solid State Ignition | 1 | 292 | 26460 | Fuel Line Clamp | 2 |
| 101 | 610118 | Spark Plug Cover | 1 | 300 | 36863 | Fuel Tank (Incl. 292 & 301) | 1 |
| 103 | 651007 | Screw, Torx T-15, 10-24 x 15/16" | 2 | 301 | 36754 | Fuel Cap (Black) | 1 |
| 103A | 650767 | Screw, 8-32 x 27/64" | 1 | 310 | 36678 | Dipstick | 1 |
| 110 | 35589 | Ground Wire | 1 | 313 | 34080 | Spacer | 1 |
| 110A | 36964 | Ground Wire | 1 | 325 | 29443 | Wire Clip | 1 |
| 111A | 611224 | Rocker On/Off Switch | 1 | 341 | 36644 | Fuel Tank Bracket | 1 |
| 119 | 36719 | Cylinder Head Gasket | 1 | 342 | 651010 | Screw, 1/4-20 x 7/8" | 2 |
| 120 | 36721 | Cylinder Head | 1 | 370A | 36261 | Identification Decal | 1 |
| 125 | 36471 | Exhaust Valve (Std.) (Incl. 151) | 1 | 370K | 36695 | Starter Decal | 1 |
| 125 | 36472 | Exhaust Valve (1/32" OS) (Incl. 151) | 1 | 380 | 640060 | Carburetor (Incl. 184) | 1 |
| | | Intake Valve (Std.) (Incl. 151) | 1 | 390 | 590736 | Rewind Starter | 1 |
| 126 | 29314C | Intake Valve (Std.) (Incl. 151) | 1 | 400 | 36720 | Gasket Set (Incl. Items Marked PK in Notes) Incl. (1) each of 26756, 27272A, 29673, 35626, 36581, 36624, 36719 | 1 |
| 126 | 29315C | Intake Valve (1/32" OS) (Incl. 151) | 1 | | | | |
| 130 | 650912 | Screw, 5/16-18 x 1-1/2" | 4 | | | | |
| 130A | 650999 | Screw, 5/16-18 x 2-41/64" | 1 | | | | |
| 135 | 34645 | Resistor Spark Plug (RN4C) | 1 | 416 | 36085 | Spark Arrestor Kit (Incl. 417) | 1 |
| 150 | 37039 | Valve Spring | 2 | 417 | 650760 | Screw, 8-32 x 3/8" | 1 |
| 151 | 31673 | Valve Spring Cap | 2 | 600 | 651013 | Washer | 1 |
| | | | | 900 | NSP | Replacement engine - None | 0 |

Tecumseh 6HP Enduro, Model #143.996005

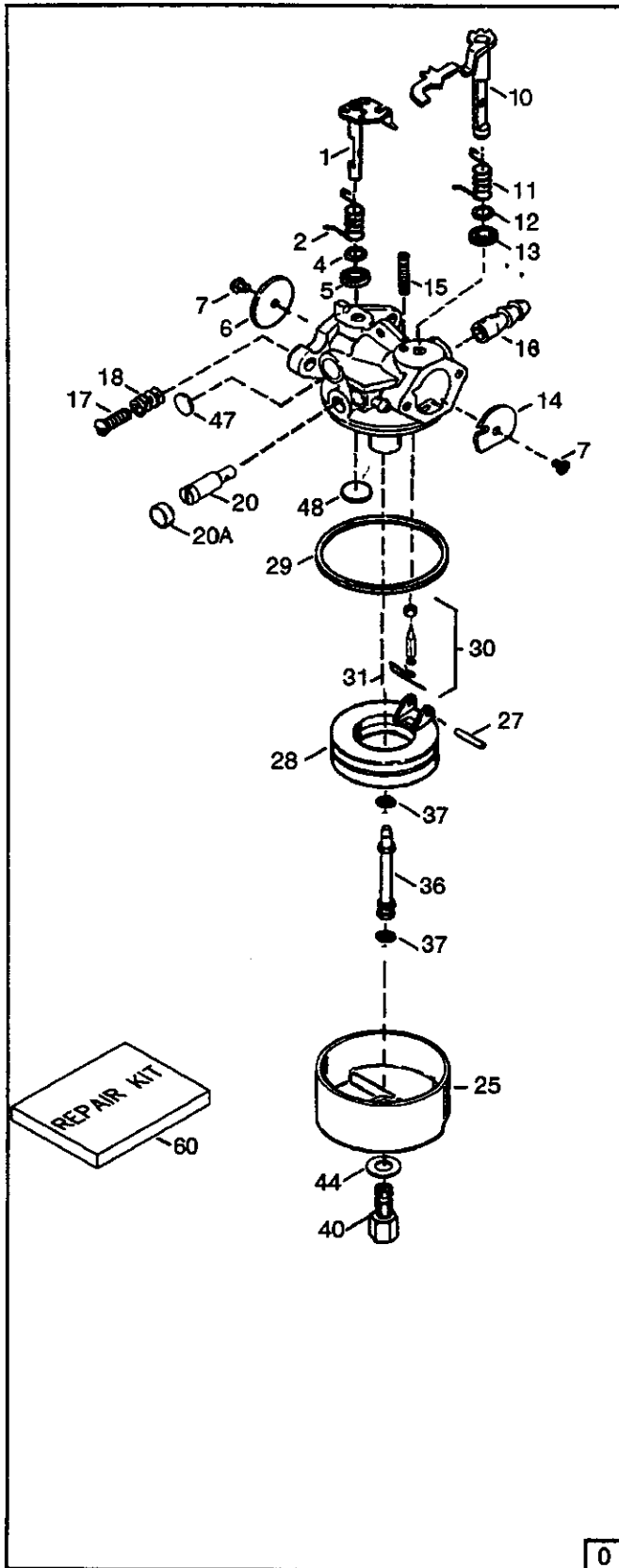

| Item | Part # | Description | Qty. |
|------|--------|---|------|
| 0 | 640060 | Carburetor (Incl. 184 of Engine Parts List) | 1 |
| 1 | 631615 | Throttle Shaft & Lever Assembly | 1 |
| 2 | 631767 | Throttle Return Spring | 1 |
| 4 | 631184 | Dust Seal Washer | 1 |
| 5 | 631183 | Dust Seal (Throttle) | 1 |
| 6 | 631036 | Throttle Shutter | 1 |
| 7 | 650506 | Shutter Screw | 2 |
| 10 | 31868 | Choke Shaft & Lever Assembly | 1 |
| 11 | 632042 | Choke Return Spring | 1 |
| 12 | 631184 | Dust Seal Washer (Choke) | 1 |
| 13 | 631183 | Dust Seal (Choke) | 1 |
| 14 | 631890 | Choke Shutter | 1 |
| 15 | 630735 | Choke Positioning Spring | 1 |
| 16 | 632164 | Fuel Fitting | 1 |
| 17 | 651025 | Throttle Crack Screw/Idle Speed Screw | 1 |
| 18 | 630766 | Tension Spring | 1 |
| 20 | 640027 | Idle Restrictor Screw | 1 |
| 20A | 640053 | Idle Restrictor Screw Cap | 1 |
| 25 | 631867 | Float Bowl | 1 |
| 27 | 631024 | Float Shaft | 1 |
| 28 | 632019 | Float | 1 |
| 29 | 631028 | Float Bowl "O" Ring | 1 |
| 30 | 631021 | Inlet Needle, Seat & Clip (Incl. 31) | 1 |
| 31 | 631022 | Spring Clip | 1 |
| 36 | 640019 | Main Nozzle Tube | 1 |
| 37 | 632547 | "O" Ring, Main Nozzle Tube | 2 |
| 40 | 640015 | High Speed Bowl Nut | 1 |
| 44 | 27110A | Bowl Nut Washer | 1 |
| 47 | 630748 | Welch Plug, Idle Mixture Well | 1 |
| 48 | 631027 | Welch Plug, Atmospheric Vent | 1 |
| 60 | 632760 | Repair kit | 1 |

Tecumseh 6HP Enduro, Model #143.996005

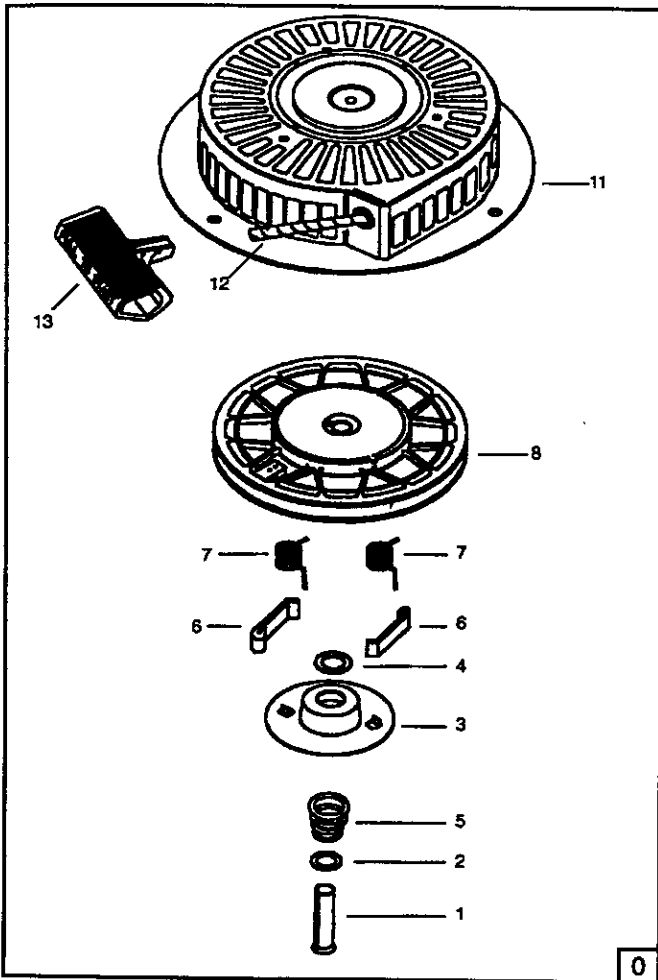

| Item | Part # | Description | Qty. |
|-------------|---------------|---------------------------------|-------------|
| 0 | 590736 | Rewind Starter | 1 |
| 1 | 590599A | Spring Pin (Incl. 4) | 1 |
| 2 | 590600 | Washer | 1 |
| 3 | 590696 | Retainer | 1 |
| 4 | 590601 | Washer | 1 |
| 5 | 590697 | Brake Spring | 1 |
| 6 | 590698 | Starter Dog | 2 |
| 7 | 590699 | Dog Spring | 2 |
| 8 | 590700 | Pulley & Rewind Spring Ass'y. | 1 |
| 11 | 590705 | Starter Housing Ass'y. | 1 |
| 12 | 590535 | Starter Rope (98" x 9/64" dia.) | 1 |
| 13 | 590701 | Starter Handle | 1 |

**Craftsman 2250 PSI Cleaning System 580.768030
Pump**

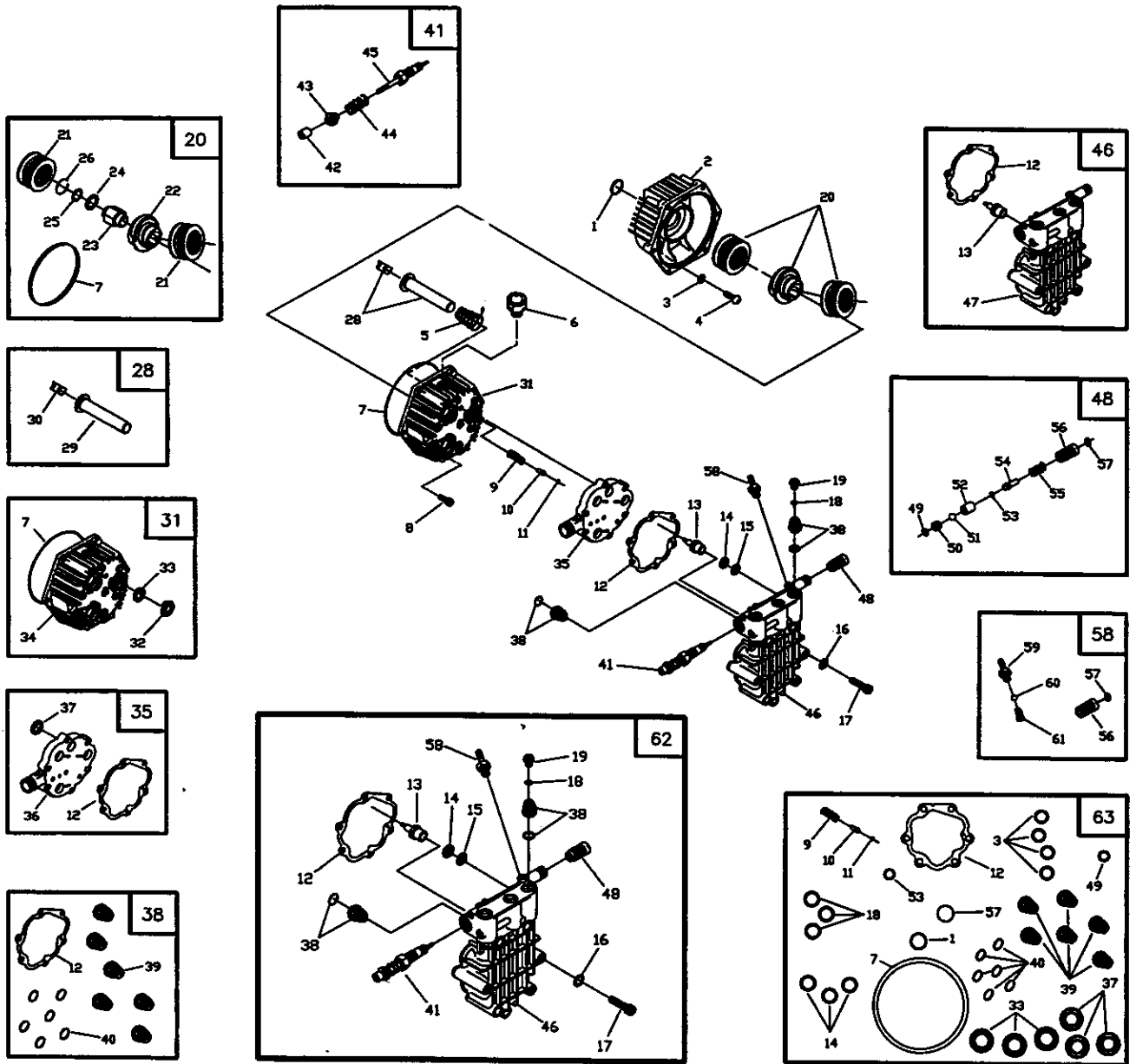

**Craftsman 2250 PSI Cleaning System 580.768030
Pump**

| <u>Item</u> | <u>Part #</u> | <u>Qty</u> | <u>Description</u> | <u>Item</u> | <u>Part #</u> | <u>Qty</u> | <u>Description</u> |
|-------------|---------------|------------|--------------------------------------|-------------|---------------|------------|--|
| 1 | B2218 | 1 | O-RING, 1.625" x 0.103 | 33 | | 3 | SEAL, Oil Piston |
| 2 | B2260 | 1 | ADAPTER, Engine | 34 | | 1 | CRANKCASE, Pump |
| 3 | B2217 | 4 | O-RING, 0.239 ID x 0.070 | 35 | B3509 | 0 | KIT, Spacer Plate |
| 4 | B2261B | 4 | SCREW, Button Hd 5/16 - 24 x 3/4" Lg | 36 | | 1 | SPACER, Inlet Plate |
| 5 | 96400 | 3 | SPRING, Piston Return | 37 | | 3 | SEAL, High Pressure Dbl. Lip |
| 6 | 99735 | 1 | ASSEMBLY, Oil Breather | 38 | B3513 | 0 | KIT, Check Valve |
| 7 | 93790 | 1 | O-RING, 114 x 119 x 2.6 | 39 | | 6 | ASSY., Check Valve |
| 8 | 40945 | 6 | SHCS, M6 x 1.0 x 20mm Lg | 40 | | 6 | O-RING, Check Valve 124 x 15.56 x 1.78 |
| 9 | 93652 | 1 | SPRING, Thermal By-Pass | 41 | B4179 | 0 | KIT, Unloader Spindle |
| 10 | 95416 | 1 | PISTON, Thermal By-Pass | 42 | | 1 | SET SCREW, M6 x 8 Lg |
| 11 | 93876 | 1 | O-RING, 2.9 x 6.5 x 1.78 | 43 | | 1 | SUPPORT, Unloader Spring |
| 12 | A2069 | 1 | GASKET, Head | 44 | | 1 | SPRING, Unloader |
| 13 | 93644 | 1 | ACTUATOR, Thermal By-Pass | 45 | | 1 | ASSY., Spindle |
| 14 | 96053 | 3 | SEAL, High Pressure | 46 | B3507 | 0 | KIT, Head |
| 15 | 96015 | 3 | RING, Bearing | 47 | | 1 | ASSY., Pump Head (Med. Frame) |
| 16 | B2665 | 6 | WASHER, Steel Special | 48 | B4180 | 0 | KIT, High Pressure Outlet |
| 17 | A2013 | 6 | BOLT, Head M8 x 1.25 x 70mm Lg | 49 | | 1 | O-RING, Spindle 6 x 10 x 1.78 |
| 18 | 97840 | 3 | O-RING, Cap 15.6 x 19.16 x 1.78 | 50 | | 1 | SEAT, Ball Unloader |
| 19 | 97841 | 3 | CAP, Outlet Port | 51 | | 1 | BALL, Stainless Steel 9/32 Dia. |
| 20 | B4178 | 0 | KIT, Axial Cam 3/4" - 6.0 Lift | 52 | | 1 | SEAT, Trapped Line Pressure |
| 21 | | 2 | BEARING SET, Thrust 15.5 | 53 | | 1 | O-RING, 3.68 x 7.24 x 1.78 |
| 22 | | 1 | CAM, Axial 7.5" Lift | 54 | | 1 | VALVE, Shuttle Piston |
| 23 | | 1 | ADAPTER, Engine Shaft | 55 | | 1 | SPRING, Piston Trapped Pressure |
| 24 | | 1 | WASHER, Thrust | 56 | | 1 | VENTURI, Chemical |
| 25 | | 1 | RETAINER, Push-On | 57 | | 1 | O-RING, Venturi 10.82 x 14.38 x 1.78 |
| 26 | | 1 | O-RING, Cam Retainer | 58 | B4183 | 0 | ASSY., Chemical Injector |
| 28 | B3478 | 0 | KIT, Piston/Shoe | 59 | | 1 | BARB HOSE, Brass with Nylon Insert |
| 29 | | 3 | ASSY., Ceramic Piston & Cap | 60 | | 1 | BALL, 5.5 dia. Chemical Injector |
| 30 | | 3 | SHOE, Piston Pivot | 61 | | 1 | SPRING, Chemical Injector |
| 31 | B3508 | 0 | KIT, Crankcase | 62 | B4182 | 0 | KIT, Complete Head |
| 32 | | 3 | SPACER, Pilot | 63 | B4181 | 0 | KIT, O-Ring/Seals |

Item numbers 20, 28, 31, 35, 38, 41, 46, 48, 58, 62, and 63 are service kits and include all parts shown within the box. Items previously described are not listed under the service kit number.

Craftsman 2250 PSI Cleaning System 580.768030
Main Unit

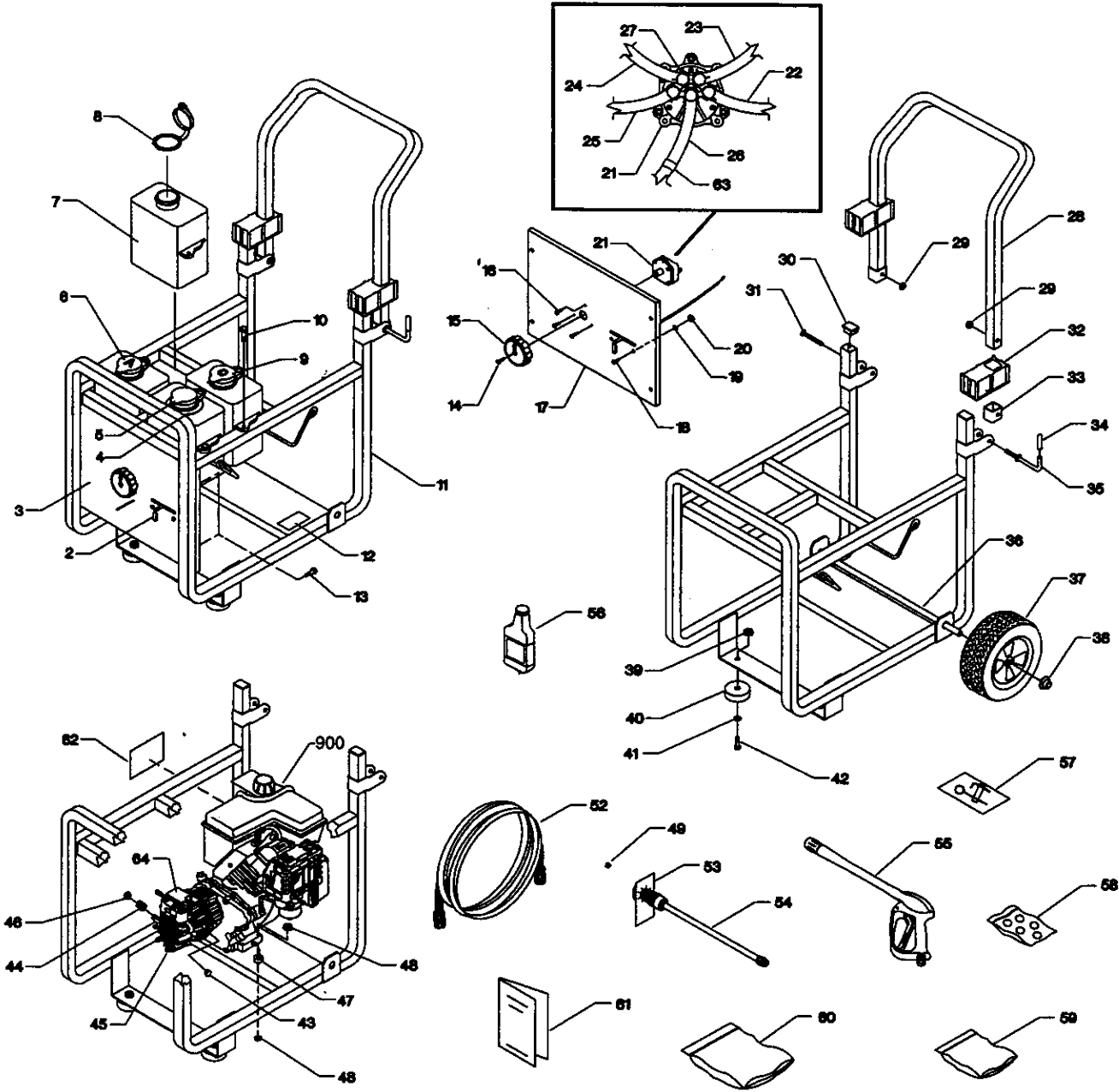

Craftsman 2250 PSI Cleaning System 580.768030

Main Unit

| <u>Item</u> | <u>Part #</u> | <u>Qty</u> | <u>Description</u> | <u>Item</u> | <u>Part #</u> | <u>Qty</u> | <u>Description</u> |
|-------------|---------------|------------|---------------------------------|-------------|---------------|------------|-----------------------------|
| 2 | B3608C | 1 | LINK, Throttle Control | 40 | 27007 | 2 | MOUNT, Vibration Donut Type |
| 3 | B3597 | 1 | DECAL, Control Panel 2250 | 41 | 50190 | 2 | FLAT WASHER, M8 |
| 4 | B3376B | 1 | TAG, System Flush Water | 42 | 42909 | 2 | HHCS, M8 x 1.25 x 30 Long |
| 5 | B3222D | 1 | CAP, Chem Container "Water" | 43 | 97100 | 1 | CAP, Outlet |
| 6 | B3222A | 1 | CAP, Chem Container "A" | 44 | 21424 | 1 | CONNECTOR, Garden Hose |
| 7 | B3594 | 4 | ASSY., Chemical Tank 1/2 Gal. | 45 | B3700D | 1 | ASSY., Pump |
| 8 | B3222B | 1 | CAP, Chem Container "B" | 46 | A1408 | 1 | CAP, Inlet |
| 9 | B3222C | 1 | CAP, Chem Container "C" | 47 | 21217 | 4 | MOUNT, Rubber Shock |
| 10 | B3695 | 8 | BOLT, 1/4" - 20 with Washer | 48 | 67989 | 8 | NUT, Hex Locking Flange M8 |
| 11 | EB3265 | 1 | CRADLE, Polo Green | 49 | 92659 | 1 | NOZZLE, Replacement |
| 12 | 96307 | 1 | DECAL, 1-800 Number | 52 | B3607 | 1 | HOSE, 1/4" x 25' |
| 13 | 86292 | 4 | SELF DRILL, 10 - 16 x 3/4" | 53 | 97566 | 1 | TAG, Nozzle Instructions |
| 14 | B3311 | 1 | SCREW, Plastite 10 - 9 | 54 | B3335B | 1 | WAND, Nozzle Hi/Lo |
| 15 | B3721 | 1 | HANDLE, 4-Way Valve | 55 | B3263 | 1 | GUN, High Pressure |
| 16 | B3377 | 3 | SCREW, Plastite 8 - 11 3/4" | 56 | AB3061B | 1 | OIL BOTTLE, 20 oz |
| 17 | EB3113 | 1 | PANEL, Control Polo Green | 57 | B3708 | 1 | KIT, Cleaning Nozzle |
| 18 | 91526 | 2 | SCREW, M5 - 0.8 x 12 | 58 | B2730 | 1 | KIT, Maintenance |
| 19 | 49226 | 2 | LOCK WASHER, M5 | 59 | B3454 | 1 | KIT, Tag |
| 20 | 51716 | 2 | NUT, Hex M5 - 0.8 | 60 | B3589 | 1 | KIT, 3 Pak Concentrate |
| 21 | B3306 | 1 | ASSY., Sub 4-Way Valve | 61 | B3595 | 1 | MANUAL |
| 22 | B3593A | 1 | HOSE, "A" - 6.5" | 62 | B3453 | 1 | DECAL, Start Instructions |
| 23 | B3593B | 1 | HOSE, "B" - 8.5" | 63 | 48031C | 2 | CLAMP, Hose 1/2" |
| 24 | B3593C | 1 | HOSE, "C" - 11.0" | 64 | B1288 | 1 | TAG, Breather |
| 25 | B3593D | 1 | HOSE, "Water" - 8" | 900 | NSP | 1 | ENGINE |
| 26 | B3601D | 1 | HOSE, Chemical Pump 10.5" | | | | |
| 27 | 48031G | 4 | CLAMP, Hose 3/16" | | | | |
| 28 | EB2555 | 1 | HANDLE, Polo Green | | | | |
| 29 | B2071 | 2 | NUT, 1/4" - 20 Flange Locking | | | | |
| 30 | 46476 | 2 | CAP PLUG, Tubing | | | | |
| 31 | 31669 | 1 | BOLT, 1/4"-20 x 1-3/4" Carriage | | | | |
| 32 | B1779 | 2 | COVER, Hinge | | | | |
| 33 | B2347 | 2 | END CAP, Tube | | | | |
| 34 | B1460 | 1 | CAP, Vinyl Black | | | | |
| 35 | B2759 | 1 | HOOK, Square Neck Gun | | | | |
| 36 | B3741 | 1 | AXLE ROD, 1/2" x 21.53" | | | | |
| 37 | B1760 | 2 | ASSY., Wheel & Tire 10" | | | | |
| 38 | 75402 | 2 | PUSHNUT, 1/2" | | | | |
| 39 | 52858 | 2 | NUT, M8 - 1.25 Locking | | | | |

Optional Accessories Not Illustrated:

| | |
|----------|-------------------------------------|
| 71-74300 | House Wash Concentrate |
| 71-74301 | Deck Wash Concentrate |
| 71-74302 | Vehicle Wash Concentrate |
| 71-74303 | Degreaser Concentrate |
| 71-74400 | Heavy Duty Turbo Nozzle |
| 71-74401 | 25' 3/8" Replacement Extension Hose |
| 71-75115 | 25' 1/4" Replacement Hose |
| 71-75116 | O Ring Repair Kit |
| 71-75187 | Garden Hose Quick Connect |
| 71-75197 | Accessory Quick Connect Kit |
| 71-75199 | Rotating Brush |
| 71-76430 | Floor/Siding Brush |
| 71-76431 | Utility Brush |

EMISSION CONTROL SYSTEM WARRANTY

CALIFORNIA & US EPA EMISSION CONTROL WARRANTY STATEMENT

The U.S. Environmental Protection Agency ("EPA"), the California Air Resources Board ("CARB") and Tecumseh Products Co. are pleased to explain the Federal and California Emission Control Systems Warranty on your new utility or lawn and garden equipment engine. In California, new 1995 and later utility and lawn and garden equipment engines must be designed, built and equipped to meet the State's stringent anti-smog standards. In other states, new 1997 and later model year engines must be designed, built and equipped, at the time of sale, to meet the U.S. EPA regulations for small no-road engines. Tecumseh Products Co. will warrant the emission control system on your utility or lawn and garden equipment engine for the time periods listed below, provided there has been no abuse, neglect, unapproved modification, or improper maintenance of your utility or lawn and garden equipment engine.

Your emission control system may include parts such as the carburetor, ignition system and exhaust system. Also included may be the compression release system and other emission-related assemblies.

Where a warrantable condition exists, Tecumseh Products Co. will repair your utility or lawn and garden equipment engine at no cost to you for diagnosis, parts and labor.

Manufacturer's Emission Control System Warranty Coverage

Emission control systems on 1995 and later model year California utility and lawn and garden equipment engines are warranted for two years as hereinafter noted. In other states, 1997 and later model year engines are also warranted for two years. If during such warranty period, any emission-related part on your engine is defective in materials or workmanship, the part will be repaired or replaced by Tecumseh Products Co.

Owner's Warranty Responsibilities

As the utility or lawn and garden equipment engine owner, you are responsible for the performance of the required maintenance listed in your Owner's Manual, but Tecumseh Products Co. will not deny warranty solely due to the lack of receipts or for your failure to provide written evidence of the performance of all scheduled maintenance.*

As the utility or lawn and garden equipment engine owner, you should however, be aware the Tecumseh Products Co. may deny you warranty coverage if your utility or lawn and garden equipment or a part thereof has failed due to abuse, neglect, improper maintenance or unapproved modifications.

You are responsible for presenting your utility or lawn or garden equipment engine to a Tecumseh Authorized Service Outlet (any Tecumseh Registered Service Dealer, Tecumseh Authorized Service Distributor or Tecumseh Central Warehouse Distributor) as soon as a problem exists. The warranty repairs should be completed in a reasonable amount of time, not to exceed 30 days.

Warranty Service can be arranged by contacting either a Tecumseh Authorized Service Outlet or by contacting Tecumseh Products Co., c/o Service manager, Engine and Transmission Group Service Division, 900 North Street, Grafton, WI 53024-1499. Telephone 1-414-377-2700, or see your local telephone yellow pages under "Engines, Gasoline" for the name, address and telephone number of a Tecumseh Authorized Service Outlet near you.

Important Note

This warranty statement explains your rights and obligations under the Emission Control Warranty ("ECS Warranty") which is provided to you by Tecumseh Products Co. pursuant to California law. Tecumseh Products Co. also provides to the original purchasers of new Tecumseh Products Co. engines. The Tecumseh Products Co. Limited Warranties for New Tecumseh Engine and Electronic Ignition Modules ("Tecumseh Products Co. Warranty") which is enclosed with all new Tecumseh Products Co. engines on a separate sheet. The ECS warranty applies only to the emission control system of your new engine. To the extent that there is any conflict in term between the ECS Warranty and the Tecumseh Products Co. Warranty, the ECS Warranty shall apply except in any circumstances in which the Tecumseh Products Co. Warranty may provide a longer warranty period. Both the ECS Warranty and the Tecumseh Products Co. Warranty describe important rights and obligations with respect to your engine.

Warranty service can only be performed by a Tecumseh Products Co. Authorized Service Outlet, or by Tecumseh Products Co. at its factory in Grafton, WI. At the time of requesting warranty service, evidence must be presented of the date of sale to the original purchaser. The purchaser shall pay any charges for making service calls and/or for transporting the products to and from the place where the inspection and/or warranty work is performed. The purchaser shall be responsible for any damage or loss incurred in connection with the transportation of any engine or any part(s) thereof submitted for inspection and/or warranty work.

If you have any questions regarding your warranty rights and responsibilities, you should contact Tecumseh Products Co. at 1-414-377-2700.

EMISSION CONTROL SYSTEM WARRANTY

Emission Control System Warranty ("ECS Warranty") for 1995 and later model year California utility and lawn and garden equipment engines (for other states, 1997 and later model year engines):

A. Applicability: This warranty shall apply to 1995 and later model year California utility and lawn and garden equipment engines (for other states, 1997 and later model year engines.) The ECS Warranty Period shall begin on the date the new engine or equipment is delivered to its original, end-use purchaser, and shall continue for 24 consecutive months thereafter.

B. General Emissions Warranty Coverage: Tecumseh Products Co. warrants to the original, end-use purchaser of the new engine or equipment and to each subsequent purchaser that each of its utility and lawn and garden equipment engines is:

1. Designed, built and equipped so as to conform with all applicable regulations by the Air Resources Board pursuant to its authority in Chapters 1 and 2, Part 5, Division 26 of the Health and Safety Code, and
2. Free from defects in materials and workmanship which, at any time during the ECS Warranty period, will cause a warranted emissions-related part to fail to be identical in all materials respects to the part as described in the engine manufacturer's application for certification.

C. The ECS Warranty only pertains to emissions-related parts on your engine, as follows:

1. Any warranted, emissions-related parts which are not scheduled for replacement as required maintenance in the Owner's Manual shall be warranted for the ECS Warranty Period. If any such part fails during the ECS Warranty Period, it shall be repaired or replaced Tecumseh Products Co. according to Subsection 4 below. Any such part repaired or replaced under the ECS Warranty shall be warranted for any remainder of the ECS Warranty Period.
2. Any warranted, emissions-related part which is scheduled only for regular inspection as specified in the Owner's Manual shall be warranted for the ECS Warranty Period. A statement in such written instructions to the effect of "repair or replace as necessary," shall not reduce the ECS Warranty Period. Any such part repaired or replaced under the ECS Warranty shall be warranted for the remainder of the ECS Warranty Period.
3. Any warranted, emissions-related part which is scheduled for replacement as required maintenance in the Owner's Manual, shall be warranted for the period of time prior to the first scheduled replacement point for that part. If the part fails prior to the first scheduled replacement, the part shall be repaired or replaced by Tecumseh Products Co. according to Subsection 4 below. Any such emissions-related part repaired or replaced under the ECS Warranty, shall be warranted for the remainder of the ECS Warranty period prior to the first scheduled replacement point for such emissions-related part.

4. Repair or replacement of any warranted, emissions related part under this ECS Warranty shall be performed at no charge at a Tecumseh Authorized Service Outlet.
5. The owner shall not be charged for diagnostic labor which leads to the determination that a part covered by the ECS Warranty is in fact defective, provided that such diagnostic work is performed at a Tecumseh Authorized Service Outlet.
6. Tecumseh Products Co. shall be liable for damages to other original engine components or approved modifications proximately caused by a failure under warranty of an emission-related part covered by the ECS warranty.
7. Throughout the ECS Warranty Period, Tecumseh Products Co. shall maintain a supply of warranted emission-related parts sufficient to meet the expected demand for such emission-related parts.
8. Any Tecumseh Products Co. authorized or approved emission-related replacement part may be used in the performance of any ECS Warranty maintenance or repair and will be provided without charge to the owner. Such use shall not reduce Tecumseh Products Co. ECS Warranty obligations.
9. Unapproved add-on or modified parts may not be used to modify or repair a Tecumseh Products Co. engine. Such use voids this ECS Warranty shall be sufficient grounds for disallowing an ECS Warranty Claim. Tecumseh Products Co. shall not be liable hereunder for failures of any warranted parts of a Tecumseh Products Co. engine caused by the use of such an unapproved add-on or modified part.

EMISSION-RELATED PARTS INCLUDE THE FOLLOWING:

1. Carburetor Assembly and its Internal Components.
 - a) Fuel filter
 - b) Carburetor gaskets
 - c) Intake pipe
2. Air Cleaner Assembly
 - a) Air Cleaner Element
3. Ignition System, including:
 - a) Spark plug
 - b) Ignition module
 - c) Flywheel assembly
4. Catalytic Muffler (if so equipped)
 - a) Muffler gasket (if so equipped)
 - b) Exhaust manifold (if so equipped)
5. Crankcase Breather Assembly and its Components
 - a) Breather connection tube

For in-home major brand repair service:

Call 24 hours a day, 7 days a week

1-800-4-MY-HOMESM (1-800-469-4663)

Para pedir servicio de reparación a domicilio – 1-800-676-5811

In Canada for all your service and parts needs call – **1-800-665-4455**
Au Canada pour tout le service ou les pièces

For the repair or replacement parts you need:

Call 7 am – 7 pm, 7 days a week

1-800-366-PART (1-800-366-7278)

Para ordenar piezas con entrega a domicilio – 1-800-659-7084

For the location of a Sears Parts and Repair Center in your area:

Call 24 hours a day, 7 days a week

1-800-488-1222

**For information on purchasing a Sears Maintenance Agreement
or to inquire about an existing Agreement:**

Call 9 am – 5 pm, Monday – Saturday

1-800-827-6655



The Service Side of SearsSM

Free Manuals Download Website

<http://myh66.com>

<http://usermanuals.us>

<http://www.somanuals.com>

<http://www.4manuals.cc>

<http://www.manual-lib.com>

<http://www.404manual.com>

<http://www.luxmanual.com>

<http://aubethermostatmanual.com>

Golf course search by state

<http://golfingnear.com>

Email search by domain

<http://emailbydomain.com>

Auto manuals search

<http://auto.somanuals.com>

TV manuals search

<http://tv.somanuals.com>