

**SEARS**

INSTRUCTION  
MANUAL

CRAFTSMAN  
ELECTRIC  
BRAD NAILER-  
MODEL NO.  
900.684253

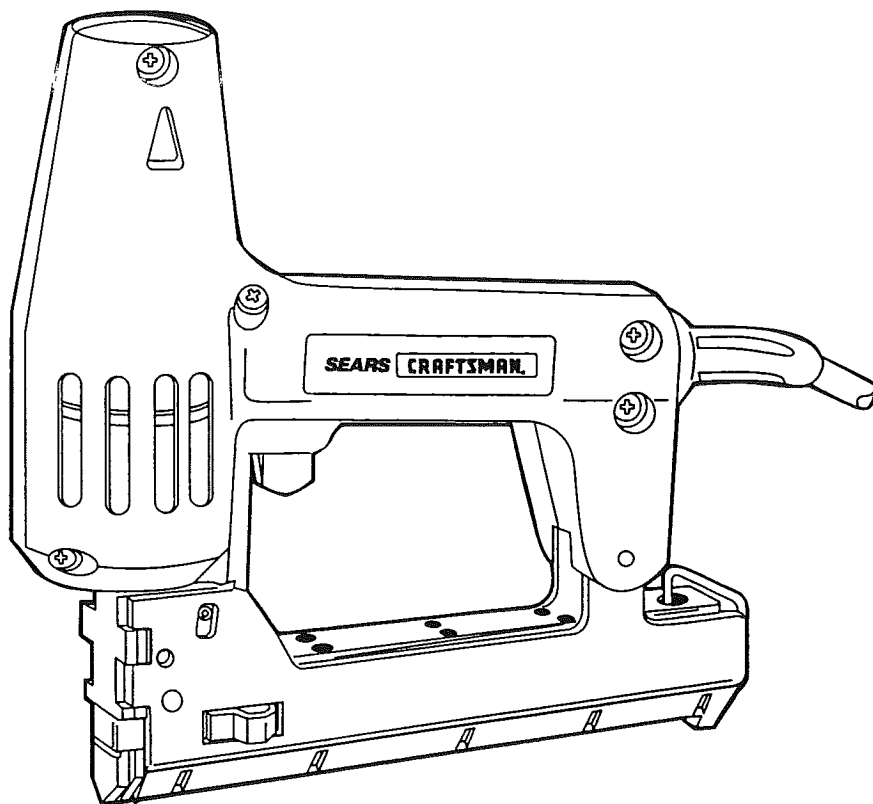

**CRAFTSMAN®**  
**ELECTRIC BRAD NAILER**

**CAUTION:**  
Carefully  
Read Rules for  
Safe Operation  
and Instructions

Introduction  
Operation  
Maintenance  
Repair Part



## FULL ONE-YEAR WARRANTY ON CRAFTSMAN ELECTRIC BRAD NAILER

If this **Craftsman Electric Brad Nailer** fails to give complete satisfaction within one year from date of purchase, return it to the nearest Sears store throughout the United States, and Sears will replace it, free of charge. If this **Electric Brad Nailer** is used for commercial or rental purposes, this warranty applies for only 90 days from the date of purchase. This warranty gives you specific legal rights, and you may also have other rights which vary from state to state.

SEARS, ROEBUCK AND CO., DEPT. 698/731A, SEARS TOWER, CHICAGO, IL 60684

### IMPORTANT SAFETY INSTRUCTIONS (FOR ALL TOOLS)

**WARNING: When using Electric Tools, basic safety precautions should always be followed to reduce the risk of fire, electric shock, and personal injury, including the following:**

1. **KEEP WORK AREA CLEAN.** Cluttered areas and benches invite injuries.
2. **CONSIDER WORK AREA ENVIRONMENT.** Don't expose power tools to rain. Don't use power tools in damp or wet locations. Keep work area well lit.
3. **GUARD AGAINST ELECTRIC SHOCK.** Prevent body contact with grounded surfaces. For example: pipes, radiators, ranges, refrigerator enclosures.
4. **KEEP CHILDREN AWAY.** All visitors should be kept away from work area. Do not let visitors contact tool or extension cord.
5. **STORE IDLE TOOLS.** When not in use, tools should be stored in dry, and high or locked-up place – out of reach of children.
6. **DON'T FORCE TOOL.** It will do the job better and safer at the rate for which it was intended.
7. **USE RIGHT TOOL.** Don't force small tool or attachment to do the job of a heavy-duty tool. Don't use tool for purpose not intended, for example, don't use circular saw for cutting tree limbs or logs.
8. **DRESS PROPERLY.** Do not wear loose clothing or jewelry. They can be caught in moving parts. Rubber gloves and non-skid footwear are recommended when working outdoors. Wear protective hair covering to contain long hair.
9. **USE SAFETY GLASSES.** Also use face or dustmask if cutting operation is dusty.
10. **DON'T ABUSE CORD.** Never carry tool by cord or yank it to disconnect from receptacle. Keep cord from heat, oil, and sharp edges.
11. **SECURE WORK.** Use clamps or a vise to hold work. It's safer than using your hand and it frees both hands to operate tool.
12. **DON'T OVERREACH.** Keep proper footing and balance at all times.
13. **MAINTAIN TOOLS WITH CARE.** Keep tools sharp and clean for better and safe performance. Follow instructions for lubrication and changing accessories. Inspect tool cords periodically and if damaged have repaired by authorized service facility. Inspect extension cords periodically and replace if damaged. Keep handles dry, clean, and free from oil and grease.
14. **DISCONNECT TOOLS.** When not in use, before servicing, and when changing accessories, such as blades, bits, cutters.
15. **REMOVE ADJUSTING KEYS AND WRENCHES.** Form habit of checking to see that keys and adjusting wrenches are removed from tool before turning it on.
16. **AVOID UNINTENTIONAL STARTING.** Don't carry plugged-in tool with finger on switch. Be sure switch is off when plugging in.
17. **OUTDOOR USE EXTENSION CORDS.** When tool is used outdoors, use only extension cords intended for use outdoors and so marked.
18. **STAY ALERT.** Watch what you are doing. Use common sense. Do not operate tool when you are tired.
19. **CHECK DAMAGED PARTS.** Before further use of the tool, a guard or other part that is damaged should be carefully checked to determine that it will operate properly and perform its intended function. Check for alignment of moving parts, binding of moving parts, breakage of parts, mounting, and any other conditions that may affect its operation. A guard or other part that is damaged should be properly repaired or replaced by an authorized service center unless otherwise indicated elsewhere in this instruction manual. Have defective switches replaced by authorized service centers. Do not use tool if switch does not turn it on and off.
20. **DO NOT OPERATE** portable electric tools near flammable liquids or in gaseous or explosive atmospheres. Motors in these tools normally spark, and the sparks might ignite fumes.

**SAVE THESE SAFETY RULES FOR FUTURE USE.**

---

### ALWAYS WEAR SAFETY GLASSES

The operation of any power tool can result in foreign objects being thrown into the eyes, which can result in severe eye injury. Always wear approved safety glasses or a face shield when working with this tool.

---

### GROUNDING

This tool should be grounded while in use to protect the operator from electric shock. The tool is equipped with an approved three-conductor cord and three-prong grounding type plug to fit the proper grounding type receptacle. The green (or green and yellow) conductor in the cord

is the grounding wire. Never connect the green (or green and yellow) wire to a live terminal. Your nailer has a plug like that shown in Figure A. An adapter, Figures B and C, is available for connecting Figure A plugs to two-prong receptacles. The green-colored rigid ear, lug, etc., must be connected to a permanent ground such as a properly grounded outlet box.

We recommend that you **never** disassemble the tool or do any rewiring in the electrical system. Any such repairs should be performed only by Sears Service Centers or other qualified service organizations. Should you be determined to make a repair yourself remember that the green colored wire is the "grounding" wire. Never connect this green wire to a "live" terminal. If you replace the plug on the power cord, be sure to connect the green wire only to the grounding (longest) prong on a 3-prong plug. Never remove the grounding prong.

**NOTE:** In the event of a malfunction, return your tool to a Sears Service Center for repair.

### EXTENSION CORDS

Tools that have 3 wire cords requiring grounding must only be used with extension cords that have 3-prong grounding type plugs and 3-pole receptacles. Only round jacketed extension cords should be used, and we recommend that they be listed by Underwriters Laboratories (U.L.). If the extension will be used outside, the cord must be suitable for outdoor use. Any cord marked as outdoor (The letters "WA" on the cord jacket indicate a cord recommended for outdoor use) can also be used for indoor work.

An extension cord must have adequate wire size (AWG or American Wire Gauge) for safety, and to prevent loss of power and overheating the smaller the gauge number of the wire, the greater the capacity of the cable, that is 16 gauge has more capacity than 18 gauge. When using more than one extension cord to make up the total length be sure each individual extension cord contains at least the minimum wire size.

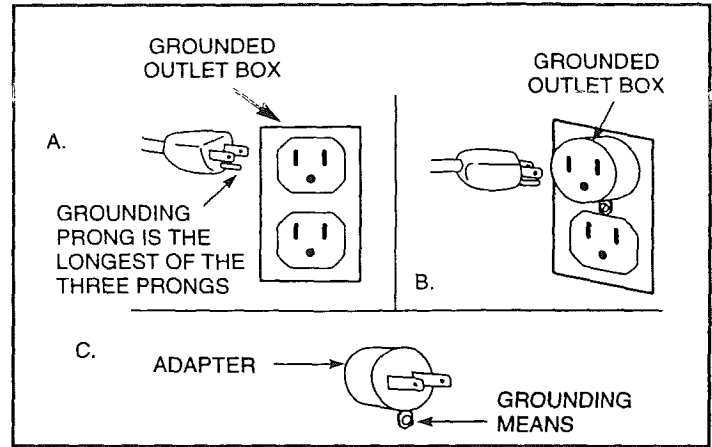

MINIMUM WIRE GAUGE REQUIREMENTS FOR THIS NAILER:

TO 25 FT. — 16 GA.  
TO 50 FT. — 14 GA.

Before using an extension cord, inspect it for loose or exposed wires, damaged insulation and defective fittings. Make any needed repairs or replace the cord if necessary.

## OPERATION

### SELECTION OF BRADS

Use only 1" or 1-1/4" long Sears brads. Incorrect brads will cause jamming. 1" long brads are recommended for installing paneling to studs or furring strips. 1-1/4" long brads are recommended only for installing paneling over drywall into studs or furring strips.

SEARS BRAD NAILS - BOX OF 500

	1"	1-1/4"		1"	1-1/4"
Off White	9-68452	9-68456	Md. Brown	9-68454	9-68458
Lt. Brown	9-68453	9-68457	Dk. Brown	9-68455	9-68459

### LOADING BRADS

Disconnect the tool from the power supply.

1. Unhook the Pusher Assembly by pushing in and lifting up as shown in Figure 1. Remove the pusher from the magazine.
2. Slide brads into magazine as shown in Figures 2 and 3.

**CAUTION:** Brad nails are available in two lengths, 1" and 1-1/4". Your Brad Nailer is capable of using either length but **1" brads are loaded differently than 1-1/4" brads. Improper loading will cause jamming.** Study Figure 3 carefully for proper loading of each length.

3. Replace the pusher assembly into the magazine and hook it into place.

The capacity of the tool is one full strip of brads. (72 brads per strip)

**NOTE:** Remove brads when unit is not in use.

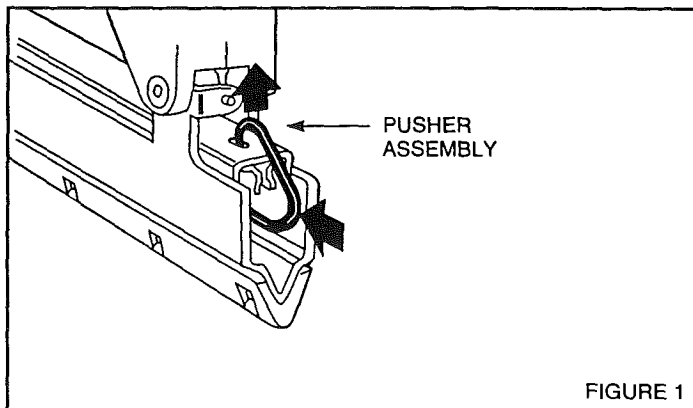

FIGURE 1

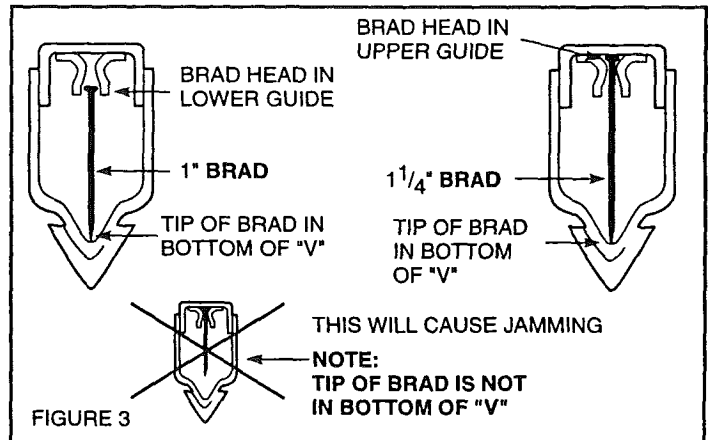
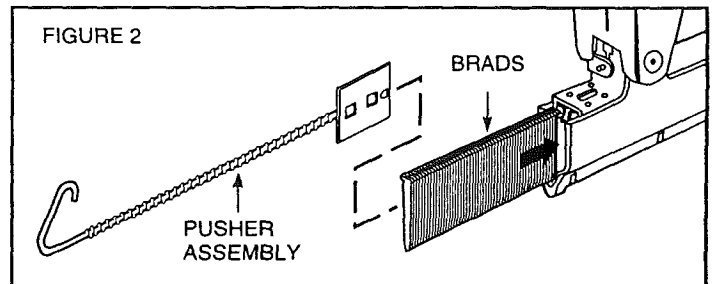

FIGURE 3

### TRIGGER SWITCH

The trigger switch is located on the underside of the handle as shown in Figure 4. Each pull of the trigger will result in one complete cycle; that is the drive and return stroke all occurring before it is possible for the operator to release the trigger. Make sure your finger is not on the trigger when connecting the tool to power supply.

**NOTE:** If this tool fails to operate, check for jamming.

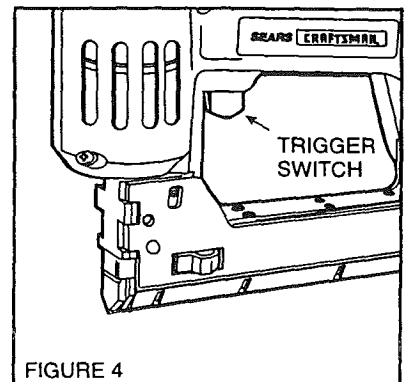

FIGURE 4

## SWITCH INTERLOCK

This tool is equipped with a trigger switch interlock so that the tool cannot be inadvertently actuated. To operate, the tool must be held firmly against the work and then the trigger switch can be depressed.

**DO NOT ATTEMPT TO OVERRIDE THIS INTERLOCK.**

## DRIVING BRADS

Each pull of the trigger will result in one complete cycle, that is the drive and return stroke all occurring before it is possible for the operator to release the trigger. Hold the tool tight against the material as shown in Figure 5, before pulling the trigger to assure safety and proper driving of the brad. Hold the nailer firmly with both hands, as shown in Figure 5. One handed operation may result in poor performance.

**NOTE:** Drive a few brads in scrap wood to get the "feel" of your Electric Brad Nailer before you attempt to do any finished work.

**NOTE:** Do not rapid fire this tool. Damage to the unit could result.

## LEVELER STRIP

Different hardnesses of the material in which you are nailing, will cause the brads to be driven to different depths. When nailing in soft pine, for example, the Electric Brad Nailer is quite capable of sinking the brad heads below the surface of the wood. In order to prevent the brad heads from sinking into the wood, a Leveler Strip is provided (see Figure 6). To prevent the brad heads from penetrating too deeply the material into which you are nailing, pull the Leveler Strip off the Electric Brad Nailer and reinstall it so that the raised boss shown in Figure 6 is in the front (where the brads come out).

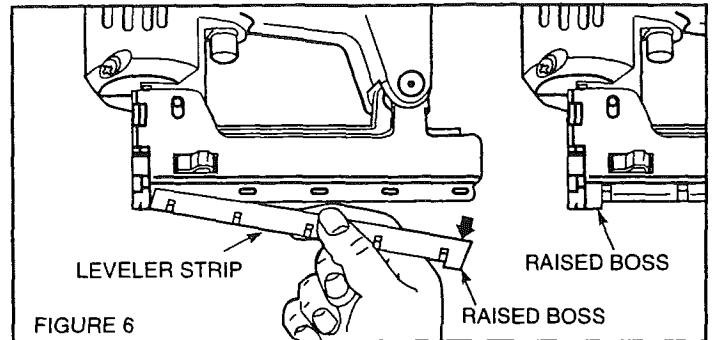
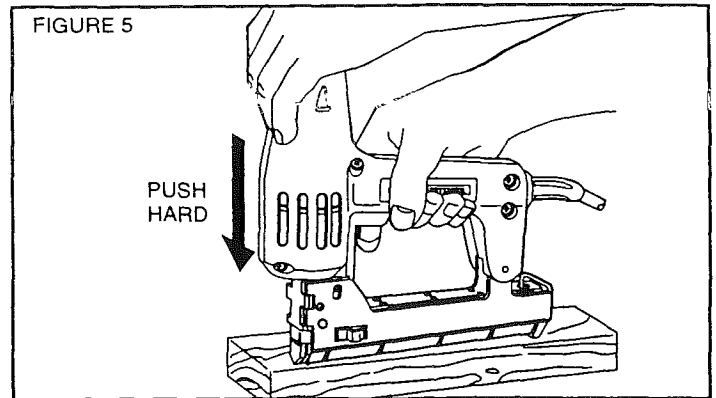

# MAINTENANCE

## WHEN SERVICING USE ONLY IDENTICAL REPLACEMENT PARTS

Only the components shown on the parts list below are to be replaced by the customer. To avoid the possibility of alteration or damage to the system, service should be performed by your nearest Sears Electric Motor Shop/Specialty repair center. Contact your nearest Sears retail store.

Avoid using solvents when cleaning plastic parts. Most plastics are susceptible to various types of commercial solvents and may be damaged by their use. Use clean clothes to remove dirt, etc.

When electric tools are used on fiberglass boats, sports cars, etc., it has been found that they are subject to accelerated wear and possible premature failure, as the fiberglass chips and grindings are highly abrasive to bearings, brushes, commutator, etc. Consequently, it is not recommended that this tool be used for continuous production work on any fiberglass material. During any use on fiberglass it is extremely important that the tool is cleaned frequently by blowing with an air jet.

**CAUTION** — Do not alter, attach special fixture, or redesign parts of this tool. Also, please follow grounding instructions as explained earlier.

## CRAFTSMAN ELECTRIC BRAD NAILER MODEL NUMBER 900.684253

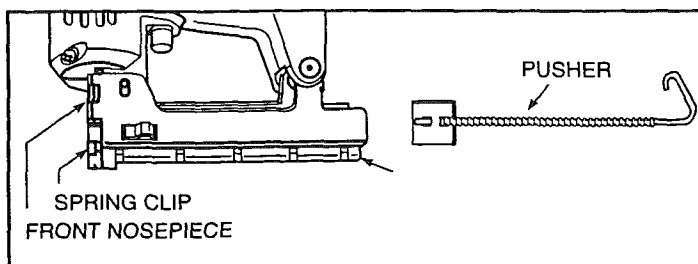

## HOW TO ORDER REPAIR PARTS

The above listed parts may be ordered from any SEARS, ROEBUCK AND CO. repair or catalog store. If the parts are not stocked locally, your order will be electronically transmitted to a Sears Repair Parts Distribution Center for expediting handling.

## TO CLEAR A JAMMED NAIL

This tool should not jam if kept clean and the correct brads are used and loaded properly. If a jam should occur, unplug the tool and unload any remaining brads. Slide jam release clip forward to relieve clamping pressure as shown in Figure 7. This may be sufficient to clear jam. If further clearing is required, the front brad guide may be moved.

**NOTE:** Misuse of the tool, such as actuating it when empty, will cause excessive heating and permanent damage to the tool.

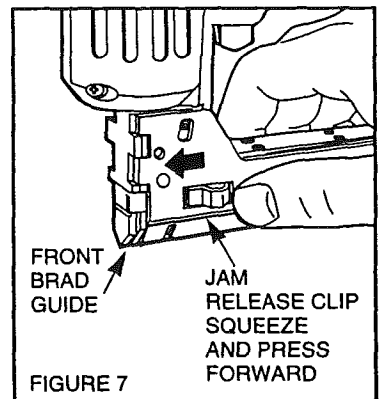

**CAUTION:** Do not alter, attach special fixtures, or redesign parts of this tool.

## WHEN ORDERING PARTS GIVE THE FOLLOWING INFORMATION AS SHOWN IN THIS LIST.

1. THE PART NUMBER
2. THE PART DESCRIPTION
3. THE MODEL NUMBER - 900.684253
4. THE NAME OF ITEM - ELECTRIC BRAD NAILER

Your Sears merchandise takes on added value when you discover that Sears has over 2,000 Service Units throughout the country.

**IMPORTANT!** Your Brad Nailer is designed for use with 1" brads. In most applications, these are sufficient.

Where paneling is being applied over drywall, a slightly longer brad may be desirable. For this purpose, 1-1/4" brads are available. (Consult your Instruction Manual for part number). When nailing through paneling, drywall, and then studding, these longer brads will perform adequately. In other applications where the brads are to be driven directly into wood, the brad heads may protrude slightly above the surface. If this situation arises, use 1" brads.

SEARS ELECTRIC BRAD NAILER — MODEL NUMBER 900.684253

The model number will be found on a nameplate attached to the handle. Always mention the Model Number in all correspondence regarding your Electric Brad Nailer or when ordering repair parts.

SEE BACK PAGE FOR PARTS ORDERING INSTRUCTIONS.

# PARTS LIST

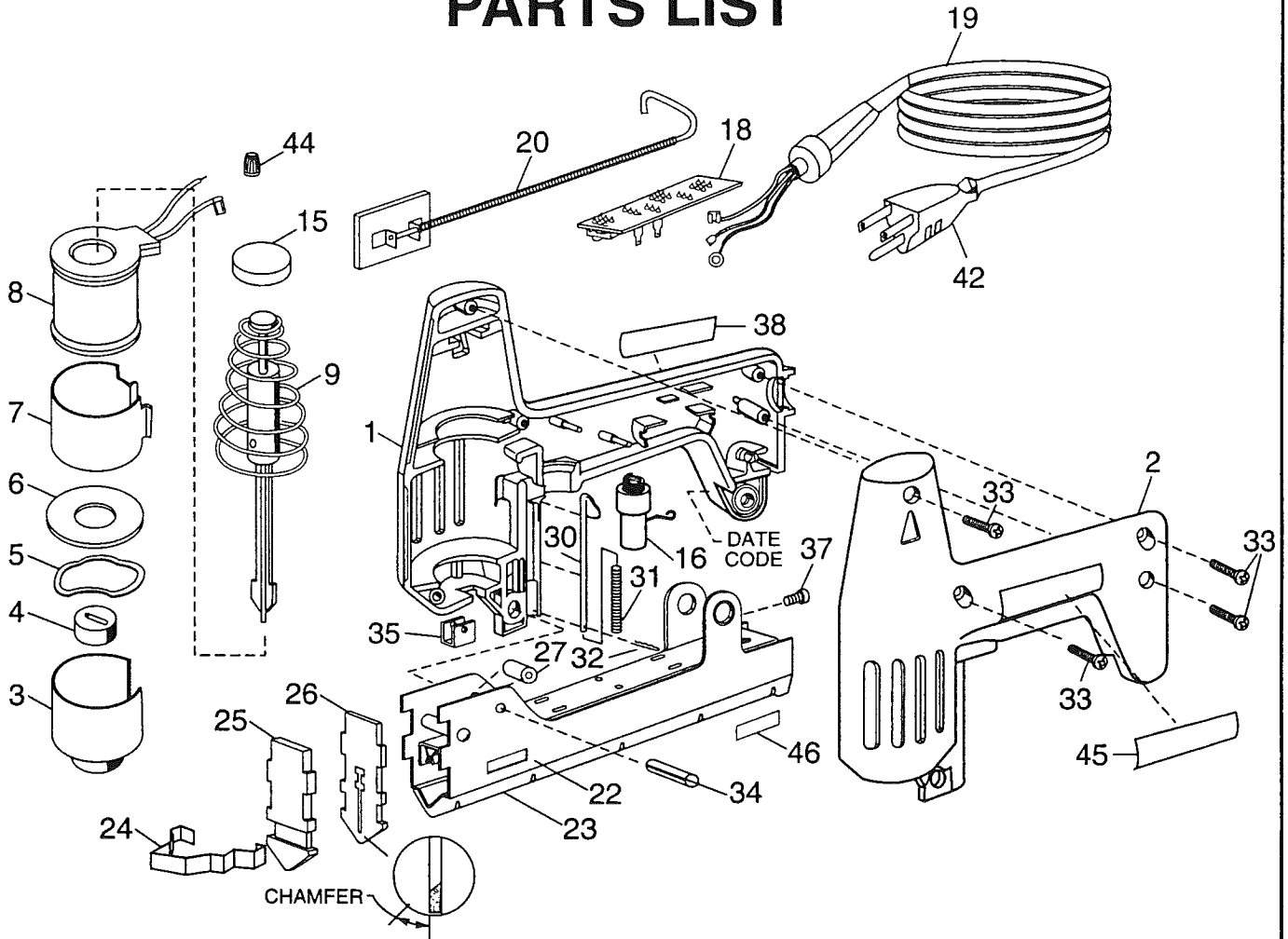

Item No.	Part No.	Description	Qty.	Item No.	Part No.	Description	Qty.
1	140795-00	Handle (Assembly Half)	1	25	142114-00	Front Nosepiece	1
2	140796-03	Handle (Cover Half)	1	Δ 26	142115-00	Rear Nosepiece	1
3	137940-01	Flux Cup	1	27	137997-00	Rubber Bushing	1
4	137941-01	Bumper	1	30	137976-00	Safety Rod	1
5	137942-00	Wavy Washer	1	31	137977-00	Safety Spring	1
6	137943-00	Flat Washer	1	32	138805-00	Hitch Pin	1
7	137944-00	Flux Ring	1	Δ 33	143062-03	6-19 x 5/8 Thread Forming Screw	5
8	138055-51	Coil	1	34	56174-00	Roll Pin	1
9	140158-00	Plunger & Spring	1	35	140503-00	U-Clip	1
15	137921-00	Return Bumper	1	Δ 37	138842-00	8-32 x 1/4 Machine Screw & Lockwasher	1
16	141682-00	Push Button & Spring	1	38	344916-00	Nameplate	1
18	140553-03	P.C. Board & Switch	1	42	234900-01	Attachment Plug	1
19	340505-00	Cord & Plug	1	44	32114-06	Terminal	1
20	140150-00	Pusher Assembly	1	45	344917-00	Label ID	1
22	137954-03	Magazine	1	46	314956-00	Caution Label	1
23	137967-00	Leveler Strip	1				
24	142113-00	Spring Clip	1				

Δ NOTES:

- 26 Chamfer on Front Face of Rear Nosepiece must be assembled facing away from Unit and toward Item 25
- 33 Torque to 10-15 In. Lbs.
- 37 Torque to 18-28 In. Lbs

EXTRA EQUIPMENT:  
740983-06 Instruction Manual

Volts	Amps
120	10.0
AC Only	

**IMPORTANT!**—To assure product SAFETY and RELIABILITY, repairs, maintenance and adjustment should be performed by Sears Service Centers or other qualified service organizations, always using Sears replacement parts.

# SEARS

INSTRUCTION  
MANUAL

SERVICE

MODEL NO.  
900.684253

HOW TO ORDER  
REPAIR PARTS

# SEARS

## ELECTRIC BRAD NAILER

Now that you have purchased your Nailer, should a need ever exist for repair parts or service, simply contact any Sears Service Center and most Sears, Roebuck and Co. stores.

Be sure to provide all pertinent facts when you call or visit.

The model number of your Nailer will be found on the nameplate attached to the handle.

**IMPORTANT!**—To assure product SAFETY and RELIABILITY, repairs, maintenance and adjustment should be performed by Sears Service Centers, always using Sears replacement parts.

**WHEN ORDERING REPAIR PARTS, ALWAYS GIVE THE FOLLOWING INFORMATION:**

- |                |                      |
|----------------|----------------------|
| ● PART NUMBER  | ● PART DESCRIPTION   |
| ● MODEL NUMBER | ● NAME OF ITEM       |
| 900.684253     | Electric Brad Nailer |

All parts listed may be ordered from any Sears Service Center and most Sears stores.

If the parts you need are not stocked locally, your order will be electronically transmitted to a Sears Repair Parts Distribution Center for handling.

## Free Manuals Download Website

<http://myh66.com>

<http://usermanuals.us>

<http://www.somanuals.com>

<http://www.4manuals.cc>

<http://www.manual-lib.com>

<http://www.404manual.com>

<http://www.luxmanual.com>

<http://aubethermostatmanual.com>

Golf course search by state

<http://golfingnear.com>

Email search by domain

<http://emailbydomain.com>

Auto manuals search

<http://auto.somanuals.com>

TV manuals search

<http://tv.somanuals.com>