

Owner's Manual

**CRAFTSMAN®**

**16.0 HP  
ELECTRIC START  
42" MOWER  
AUTOMATIC  
LAWN TRACTOR**

Model No.  
**917.271080**

- **Safety**
- **Assembly**
- **Operation**
- **Maintenance**
- **Repair Parts**

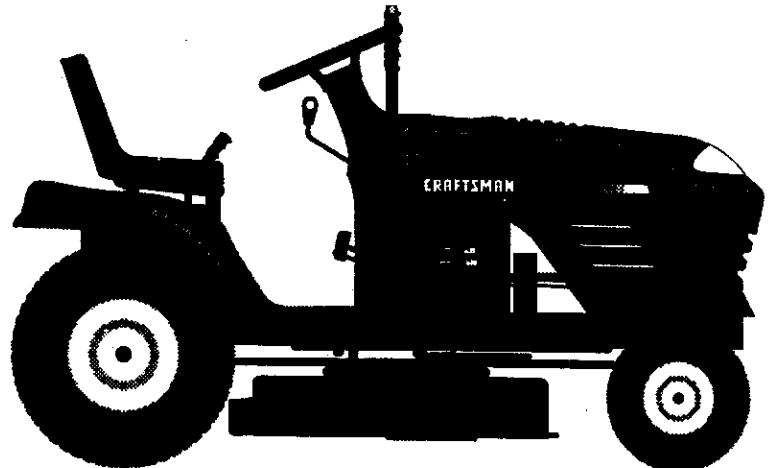

This product has a low emission engine which operates differently from previously built engines. Before you start the engine, read and understand this Owner's Manual.

**CAUTION:**

Read and follow all  
Safety Rules and Instructions  
before operating this equip-  
ment.

For answers to your questions  
about this product, Call:

**1-800-659-5917**  
Sears Craftsman Help Line  
5 am - 5 pm, Mon - Sat

Sears, Roebuck and Co., Hoffman Estates, IL 60179

Visit our Craftsman Website: [www.sears.com/craftsman](http://www.sears.com/craftsman)

## TABLE OF CONTENTS

Warranty .....	2	Maintenance .....	18
Safety Rules .....	2	Service and Adjustments .....	22
Product Specifications .....	5	Storage .....	28
Assembly .....	8	Troubleshooting .....	29
Operation .....	11	Repair Parts .....	34
Maintenance Schedule .....	18	Parts Ordering .....	Back Cover

## WARRANTY

### LIMITED TWO YEAR WARRANTY ON CRAFTSMAN RIDING EQUIPMENT

For two (2) years from the date of purchase, if this Craftsman Riding Equipment is maintained, lubricated and tuned up according to the instructions in the owner's manual, Sears will repair or replace, free of charge, any parts found to be defective in material or workmanship.

This Warranty does not cover:

- Expendable items which become worn during normal use, such as blades, spark plugs, air cleaners, belts, etc.
- Tire replacement or repair caused by punctures from outside objects, such as nails, thorns, stumps, or glass.
- Repairs necessary because of operator abuse, negligence, improper storage or accident or the failure to maintain the equipment according to the instructions contained in the owner's manual.
- Riding equipment used for commercial or rental purposes.

### LIMITED 90 DAY WARRANTY ON BATTERY

For ninety (90) days from date of purchase, if any battery included with this riding equipment proves defective in material or workmanship and our testing determines the battery will not hold a charge, Sears will replace the battery at no charge. In-home warranty service on your Craftsman riding equipment is available at no charge for 30 days from the date of purchase. Please contact your nearest service center. After 30 days from the date of purchase, warranty service is available by taking your Craftsman riding equipment to your nearest Sears Service Center. (In-home warranty service will still be available after 30 days from the date of purchase but a standard trip charge will apply). This warranty applies only while this product is in the United States. This Warranty gives you specific legal rights, and you may also have other rights which may vary from state to state.

Sears, Roebuck and Co., D/817 WA, Hoffman Estates, IL 60179

## SAFETY RULES

### GENERAL OPERATION

- Read, understand, and follow all instructions in the manual and on the machine before starting.
- Only allow responsible adults, who are familiar with the instructions, to operate the machine.
- Clear the area of objects such as rocks, toys, wire, etc., which could be picked up and thrown by the blade.
- Be sure the area is clear of other people before mowing. Stop machine if anyone enters the area.
- Never carry passengers.
- Do not mow in reverse unless absolutely necessary. Always look down and behind before and while backing.
- Be aware of the mower discharge direction and do not point it at anyone. Do not operate the mower without either the entire grass catcher or the guard in place.
- Slow down before turning.
- Never leave a running machine unattended. Always turn off blades, set parking brake, stop engine, and remove keys before dismounting.

## SAFETY RULES

- Turn off blades when not mowing.
- Stop engine before removing grass catcher or unclogging chute.
- Mow only in daylight or good artificial light.
- Do not operate the machine while under the influence of alcohol or drugs.
- Watch for traffic when operating near or crossing roadways.
- Use extra care when loading or unloading the machine into a trailer or truck.

### SLOPE OPERATION

Slopes are a major factor related to loss-of-control and tipover accidents, which can result in severe injury or death. All slopes require extra caution. If you cannot back up the slope or if you feel uneasy on it, do not mow it.

#### DO:

- Mow up and down slopes, not across.
- Remove obstacles such as rocks, tree limbs, etc.
- Watch for holes, ruts, or bumps. Uneven terrain could overturn the machine. Tall grass can hide obstacles.
- Use slow speed. Choose a low gear so that you will not have to stop or shift while on the slope.
- Follow the manufacturer's recommendations for wheel weights or counterweights to improve stability.
- Use extra care with grass catchers or other attachments. These can change the stability of the machine.
- Keep all movement on the slopes slow and gradual. Do not make sudden changes in speed or direction.
- Avoid starting or stopping on a slope. If tires lose traction, disengage the blades and proceed slowly straight down the slope.

#### DO NOT:

- *Do not* turn on slopes unless necessary, and then, turn slowly and gradually downhill, if possible.
- *Do not* mow near drop-offs, ditches, or embankments. The mower could suddenly turn over if a wheel is over the edge of a cliff or ditch, or if an edge caves in.
- *Do not* mow on wet grass. Reduced traction could cause sliding.

- *Do not* try to stabilize the machine by putting your foot on the ground.
- *Do not* use grass catcher on steep slopes.

### CHILDREN

Tragic accidents can occur if the operator is not alert to the presence of children. Children are often attracted to the machine and the mowing activity. *Never* assume that children will remain where you last saw them.

- Keep children out of the mowing area and under the watchful care of another responsible adult.
- Be alert and turn machine off if children enter the area.
- Before and when backing, look behind and down for small children.
- Never carry children. They may fall off and be seriously injured or interfere with safe machine operation.
- Never allow children to operate the machine.
- Use extra care when approaching blind corners, shrubs, trees, or other objects that may obscure vision.

### SERVICE

- Use extra care in handling gasoline and other fuels. They are flammable and vapors are explosive.
  - Use only an approved container.
  - Never remove gas cap or add fuel with the engine running. Allow engine to cool before refueling. Do not smoke.
  - Never refuel the machine indoors.
  - Never store the machine or fuel container inside where there is an open flame, such as a water heater.
- Never run a machine inside a closed area.
- Keep nuts and bolts, especially blade attachment bolts, tight and keep equipment in good condition.
- Never tamper with safety devices. Check their proper operation regularly.
- Keep machine free of grass, leaves, or other debris build-up. Clean oil or fuel spillage. Allow machine to cool before storing.
- Stop and inspect the equipment if you strike an object. Repair, if necessary,

## SAFETY RULES

before restarting.

- Never make adjustments or repairs with the engine running.
- Grass catcher components are subject to wear, damage, and deterioration, which could expose moving parts or allow objects to be thrown. Frequently check components and replace with

manufacturer's recommended parts, when necessary.

- Mower blades are sharp and can cut. Wrap the blade(s) or wear gloves, and use extra caution when servicing them.
- Check brake operation frequently. Adjust and service as required.

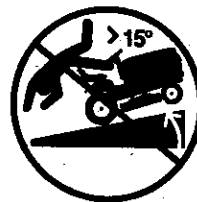

- Be sure the area is clear of other people before mowing. Stop machine if anyone enters the area.
- Never carry passengers.
- Do not mow in reverse unless absolutely necessary. Always look down and behind before and while backing.
- Never carry children. They may fall off and be seriously injured or interfere with safe machine operation.
- Keep children out of the mowing area and under the watchful care of another responsible adult.
- Be alert and turn machine off if children enter the area.
- Before and when backing, look behind and *down* for small children.
- Mow up and down slopes (15° Max), not across.
- Remove obstacles such as rocks, tree limbs, etc.
- Watch for holes, ruts, or bumps. Uneven terrain could overturn the machine. *Tall grass can hide obstacles.*
- Use slow speed. Choose a low gear so that you will not have to stop or shift while on the slope.
- Avoid starting or stopping on a slope. If tires lose traction, disengage the blades and proceed slowly *straight* down the slope.
- *Do not* turn on slopes unless necessary, and then, turn slowly and gradually downhill, if possible.

▲ Look for this symbol to point out important safety precautions. It means **CAUTION!!! BECOME AWARE!!! YOUR SAFETY IS INVOLVED.**

▲ **CAUTION:** In order to prevent accidental starting when setting up, transporting, adjusting or making repairs always disconnect spark plug wire and place wire where it cannot contact spark plug.

▲ **WARNING:** The engine exhaust from this product contains chemicals known to the State of California to cause cancer, birth defects, or other reproductive harm.

## PRODUCT SPECIFICATIONS

GASOLINE CAPACITY AND TYPE:	1.25 GALLONS UNLEADED REGULAR
OIL TYPE (API-SF/SG/SH):	SAE 10W30 (above 32°F) SAE 5W30 (below 32°F)
OIL CAPACITY:	W/FILTER: 4.0 PINTS W/O FILTER: 3.5 PINTS
SPARK PLUG: (GAP: .040")	Champion RC12YC
VALVE CLEARANCE:	NOT ADJUSTABLE
GROUND SPEED (MPH):	FORWARD: 0 - 5.5 REVERSE: 0 - 2.4
TIRE PRESSURE:	FRONT: 14 PSI REAR: 10 PSI
CHARGING SYSTEM:	15 AMPS @ 3600RPM
BATTERY:	AMP/HR: 30 MIN. CCA: 240 CASE SIZE: U1R
BLADE BOLT TORQUE:	27-35 FT. LBS.

**CONGRATULATIONS** on your purchase of a Craftsman Tractor. It has been designed, engineered and manufactured to give you the best possible dependability and performance. Should you experience any problem you cannot easily remedy, please contact your nearest Sears Authorized Service Center.

We have competent, well-trained technicians and the proper tools to service or repair this tractor. Please read and retain this manual. The instructions will enable you to assemble and maintain your tractor properly. Always observe the "SAFETY RULES".

### MAINTENANCE AGREEMENT

A Sears Maintenance Agreement is available on this product. Contact your nearest Sears store for details.

### CUSTOMER RESPONSIBILITIES

- Read and observe the safety rules.
- Follow a regular schedule in maintaining, caring for and using your tractor.
- Follow the instructions under "Maintenance" and "Storage" sections of this owner's manual.

**▲WARNING:** This tractor is equipped with an internal combustion engine and should not be used on or near any unimproved forest-covered, brush-covered or grass-covered land unless the engine's exhaust system is equipped with a spark arrester meeting applicable local or state laws (if any). If a spark arrester is used, it should be maintained in effective working order by the operator.

In the state of California the above is required by law (Section 4442 of the California Public Resources Code). Other states may have similar laws. Federal laws apply on federal lands. A spark arrester for the muffler is available through your nearest Sears Authorized Service Center (See REPAIR PARTS section of this manual).

# CONTENTS OF HARDWARE PACK

## PARTS BAG CONTENTS SHOWN FULL SIZE

(1) Large Flat Washer

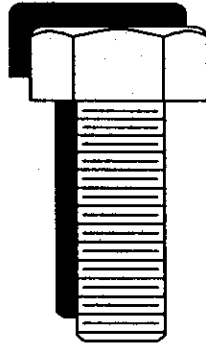
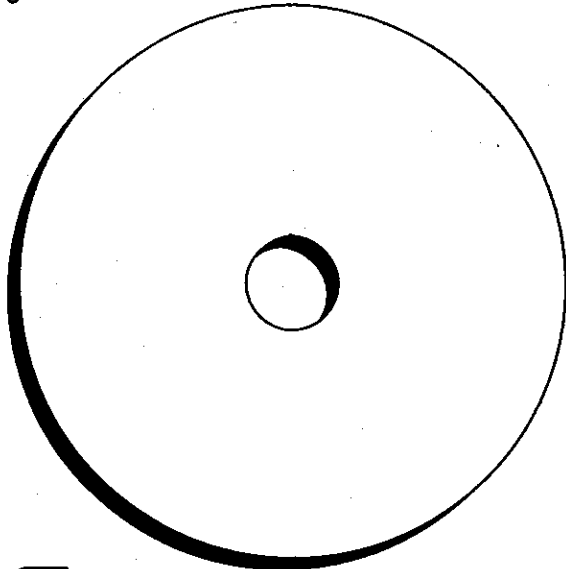

(1) Hex Bolt  
3/8-16 x 1



(1) Lockwasher  
3/8



(1) Hex Bolt  
5/16-18 x 1-1/4



(1) Locknut  
5/16-18

(1) Shoulder Bolt  
5/16-18

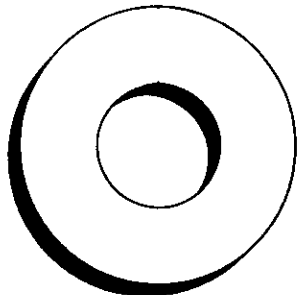
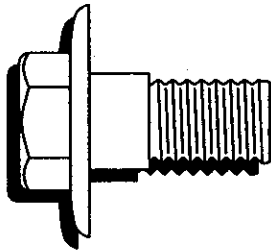

(1) Washer  
17/32 x 1-3/16 x 12 Gauge

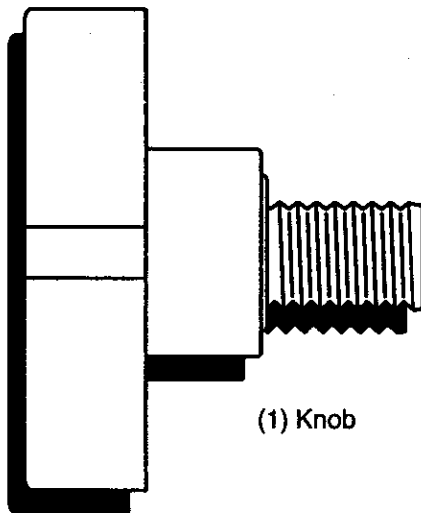

(1) Knob

# CONTENTS OF HARDWARE PACK

## PARTS BAG CONTENTS SHOWN FULL SIZE

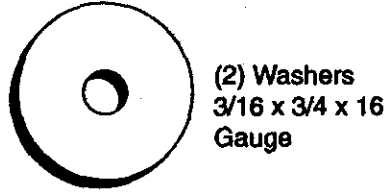
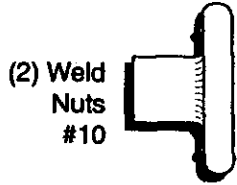
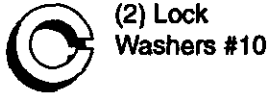
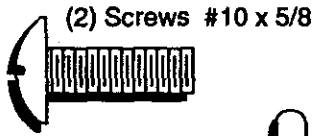

### Parts packet separately in carton

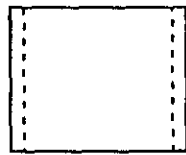
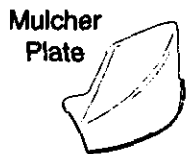
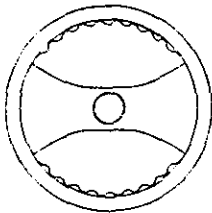
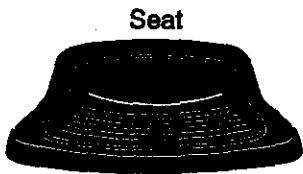

### Parts Bag contents not shown full size

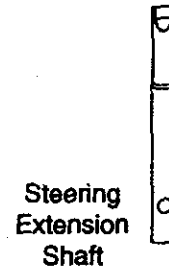
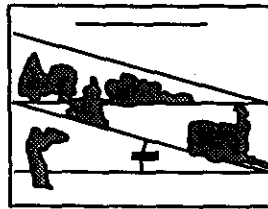
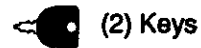
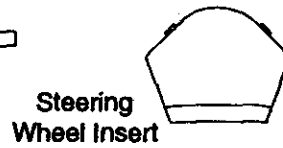
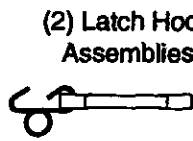

# ASSEMBLY

Your new tractor has been assembled at the factory with exception of those parts left unassembled for shipping purposes. To ensure safe and proper operation of your tractor all parts and hardware you assemble must be tightened securely. Use the correct tools as necessary to insure proper tightness. Review the video cassette before you begin.

## TOOLS REQUIRED FOR ASSEMBLY

A socket wrench set will make assembly easier. Standard wrench sizes you need are listed below.

- |                         |                                  |
|-------------------------|----------------------------------|
| (1) 9/16" wrench        | (1) 3/4" Socket w/ drive ratchet |
| (1) Pliers              | (1) Phillips Screwdriver         |
| (2) 1/2" wrench         |                                  |
| (1) Utility knife       |                                  |
| (1) Tire pressure gauge |                                  |

When right or left hand is mentioned in this manual, it means, from your point of view, when you are in the operating position (seated behind the steering wheel).

## TO REMOVE TRACTOR FROM CARTON

### UNPACK CARTON

- Remove all accessible loose parts and parts boxes from shipping carton (See page 6).
- Cut, from top to bottom, along lines on all four corners of shipping carton, and lay panels flat.
- Check for any additional loose parts or boxes and remove.

## BEFORE ROLLING TRACTOR OFF SKID

### ATTACH STEERING WHEEL

### ASSEMBLE EXTENSION SHAFT AND BOOT

- Slide extension shaft onto lower steering shaft. Align mounting holes in extension and lower shafts and install 5/16 hex bolt and locknut. Tighten securely.

**IMPORTANT:** Tighten bolt and nut securely to 18-22 ft. lbs. torque.

- Place tabs of steering boot over tab slots in dash and push down to secure.

### INSTALL STEERING WHEEL

- Position front wheels of the tractor so they are pointing straight forward.
- Slide steering wheel adapter onto steering shaft extension.
- Position steering wheel so cross bars are horizontal (left to right) and slide inside boot and onto adapter.
- Assemble large flat washer, 3/8 lock washer, 3/8 hex bolt and tighten securely.
- Snap steering wheel insert into center of steering wheel.

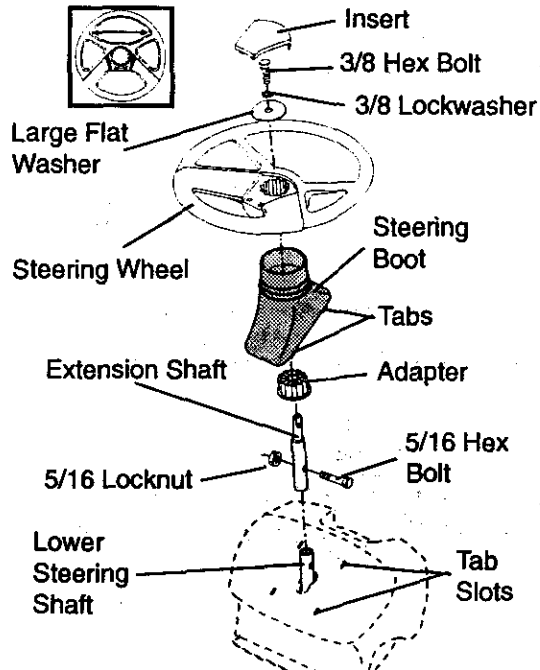

- Remove protective materials from tractor hood and grill.

**IMPORTANT:** Check for and remove any staples in skid that may puncture tires where tractor is to roll off skid.

## TO ROLL TRACTOR OFF SKID (See Operation section for location and function of controls)

- Press lift lever plunger and raise attachment lift lever to its highest position.
- Release parking brake by depressing clutch/brake pedal.
- Place freewheel control in freewheeling position to disengage transmission (See "TO TRANSPORT" in the Operation section of this manual).
- Roll tractor forward off skid.
- Remove banding holding discharge guard up against tractor.



## HOW TO SET UP YOUR TRACTOR CHECK BATTERY

- Lift seat pan to raised position and open battery box door.
- If this battery is put into service after month and year indicated on label (label located between terminals) charge battery for minimum of one hour at 6-10 amps. (See "BATTERY" in Maintenance section of this manual for charging instructions).

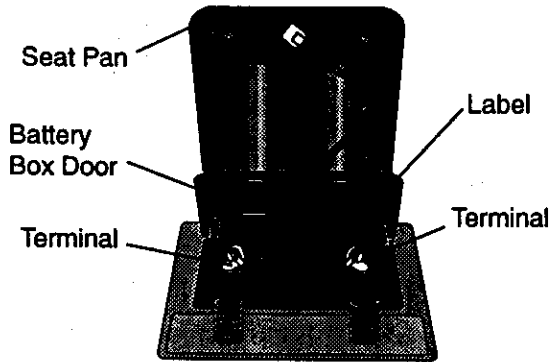

### INSTALL SEAT

Adjust seat before tightening adjustment knob.

- Remove cardboard packing on seat pan.
- Place seat on seat pan and assemble shoulder bolt. Tighten shoulder bolt securely.
- Assemble adjustment knob and flat washer loosely. Do not tighten.
- Lower seat into operating position and sit on seat.
- Slide seat until a comfortable position is reached which allows you to press clutch/brake pedal all the way down.
- Get off seat without moving its adjusted position.
- Raise seat and tighten adjustment knob securely.

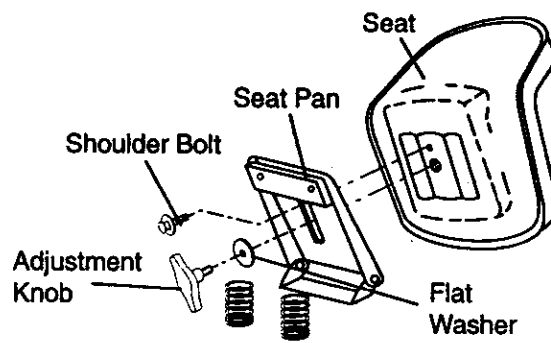

### CHECK TIRE PRESSURE

The tires on your tractor were overinflated at the factory for shipping purposes. Correct tire pressure is important for best cutting performance.

- Reduce tire pressure to PSI shown in "PRODUCT SPECIFICATIONS" section of this manual.

### CHECK DECK LEVELNESS

For best cutting results, mower housing should be properly leveled. See "TO LEVEL MOWER HOUSING" in the Service and Adjustments section of this manual.

## CHECK FOR PROPER POSITION OF ALL BELTS

See the figures that are shown for replacing motion and mower blade drive belts in the Service and Adjustments section of this manual. Verify that the belts are routed correctly.

## CHECK BRAKE SYSTEM

After you learn how to operate your tractor, check to see that the brake is properly adjusted. See "TO ADJUST BRAKE" in the Service and Adjustments section of this manual.

## INSTALL MULCHER PLATE

- Install two latch hooks to mulcher plate using screw, washer, lock washer, and weld nut as shown.

**NOTE:** Pre-assemble weld nut to latch hook by inserting weld nut from the top with hook pointing down.

- Tighten hardware securely.
- Raise and hold deflector shield in upright position.
- Place front of mulcher plate over front of mower deck opening and slide into place, as shown.
- Hook front latch into hole on front of mower deck.
- Hook rear latch into hole on back of mower deck.

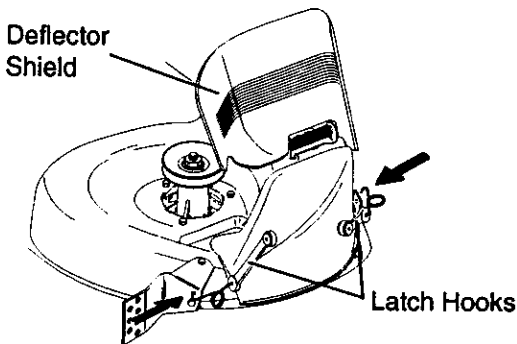
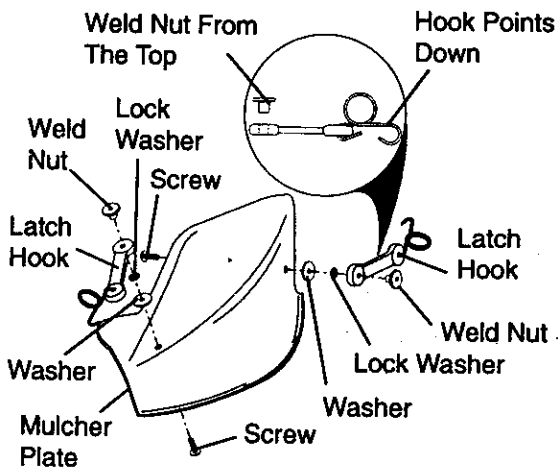

**▲ CAUTION:** Do not remove discharge guard from mower. Raise and hold guard when attaching mulcher plate and allow it to rest on plate while in operation.

## TO CONVERT TO BAGGING OR DISCHARGING

Simply remove mulcher plate and store in a safe place. Your mower is now ready for discharging or installation of optional grass catcher accessory.

**NOTE:** It is not necessary to change blades. The mulcher blades are designed for discharging and bagging also.

## ✓ CHECKLIST

PLEASE REVIEW THE FOLLOWING CHECKLIST:

- ✓ All assembly instructions have been completed.
- ✓ No remaining loose parts in carton.
- ✓ Battery is properly prepared and charged. (Minimum 1 hour at 6 amps).
- ✓ Seat is adjusted comfortably and tightened securely.
- ✓ All tires are properly inflated. (For shipping purposes, the tires were overinflated at the factory).
- ✓ Be sure mower deck is properly leveled side-to-side/front-to-rear for best cutting results. (Tires must be properly inflated for leveling).
- ✓ Check mower and drive belts. Be sure they are routed properly around pulleys and inside all belt keepers.
- ✓ Check wiring. See that all connections are still secure and wires are properly clamped.
- ✓ Before driving tractor, be sure free-wheel control is in drive position.

WHILE LEARNING HOW TO USE YOUR TRACTOR, PAY EXTRA ATTENTION TO THE FOLLOWING IMPORTANT ITEMS:

- ✓ Engine oil is at proper level.
- ✓ Fuel tank is filled with fresh, clean, regular unleaded gasoline.
- ✓ Become familiar with all controls - their location and function. Operate them before you start the engine.
- ✓ Be sure brake system is in safe operating condition.
- ✓ It is important to purge the transmission before operating your tractor for the first time. Follow proper starting and transmission purging instructions (See "TO START ENGINE" and "PURGE TRANSMISSION" in the Operation section of this manual).

# OPERATION

These symbols may appear on your tractor or in literature supplied with the product. Learn and understand their meaning.



BATTERY



CAUTION OR WARNING



REVERSE



FORWARD



FAST



SLOW



ENGINE ON



ENGINE OFF



OIL PRESSURE

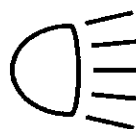

LIGHTS ON



OVER TEMP LIGHT



MOWER LIFT



FUEL



CHOKE



MOWER HEIGHT



PARKING BRAKE LOCKED



UNLOCKED



ATTACHMENT CLUTCH ENGAGED



REVERSE



NEUTRAL



HIGH



LOW



PARKING BRAKE



IGNITION



ATTACHMENT CLUTCH DISENGAGED



KEEP AREA CLEAR



SLOPE HAZARDS



(SEE SAFETY RULES SECTION)



DANGER, KEEP HANDS AND FEET AWAY

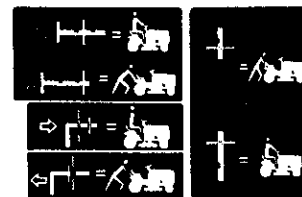

FREE WHEEL (Automatic Models only)

## KNOW YOUR TRACTOR

### READ THIS OWNER'S MANUAL AND SAFETY RULES BEFORE OPERATING YOUR TRACTOR

Compare the illustrations with your tractor to familiarize yourself with the locations of various controls and adjustments. Save this manual for future reference.

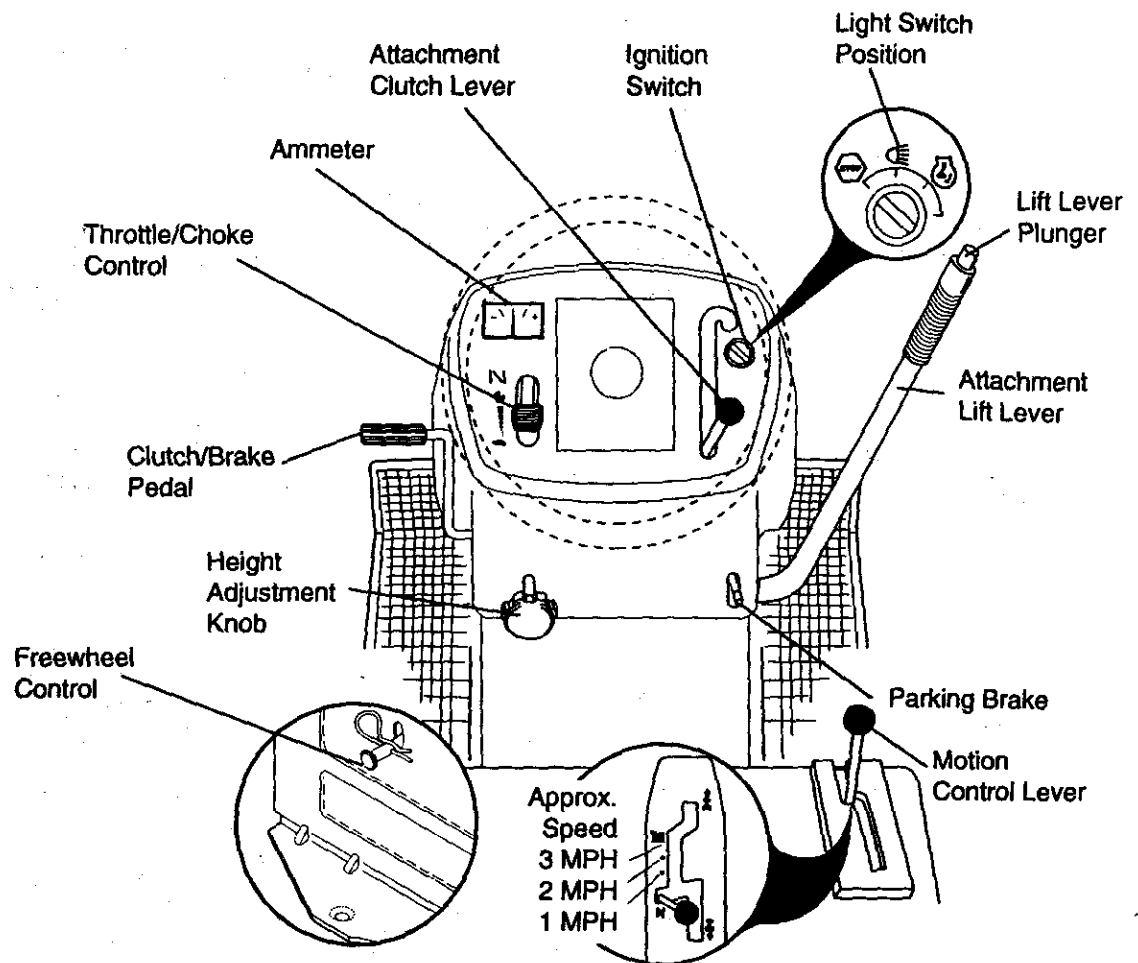

---

Our tractors conform to the safety standards of the American National Standards Institute.

---

**ATTACHMENT CLUTCH LEVER:** Used to engage the mower blades, or other attachments mounted to your tractor.

**LIGHT SWITCH:** Turns the headlights on and off.

**THROTTLE/CHOKE CONTROL:** Used to control engine speed.

**CLUTCH/BRAKE PEDAL:** Used for declutching and braking the tractor and starting the engine.

**FREEWHEEL CONTROL:** Disengages transmission for pushing or slowly towing the tractor with the engine off.

**MOTION CONTROL LEVER:** Selects the speed and direction of the tractor.

**ATTACHMENT LIFT LEVER:** Used to raise and lower the mower deck or other attachments mounted to your tractor.

**LIFT LEVER PLUNGER:** Used to release attachment lift lever when changing its position.

**IGNITION SWITCH:** Used for starting and stopping the engine.

**AMMETER:** Indicates battery charging (+) or discharging (-).

**PARKING BRAKE:** Locks clutch/brake into the brake position.

**HEIGHT ADJUSTMENT KNOB -** Used to adjust the mower cutting height.



The operation of any tractor can result in foreign objects thrown into the eyes, which can result in severe eye damage. Always wear safety glasses or eye shields while operating your tractor or performing any adjustments or repairs. We recommend a wide vision safety mask over spectacles, or standard safety glasses.

## HOW TO USE YOUR TRACTOR TO SET PARKING BRAKE

Your tractor is equipped with an operator presence sensing switch. When engine is running, any attempt by the operator to leave the seat without first setting the parking brake will shut off the engine.

- Depress clutch/brake pedal into full "BRAKE" position and hold.
- Place parking brake lever in "ENGAGED" position and release pressure from clutch/brake pedal. Pedal should remain in "BRAKE" position. Make sure parking brake will hold tractor secure.

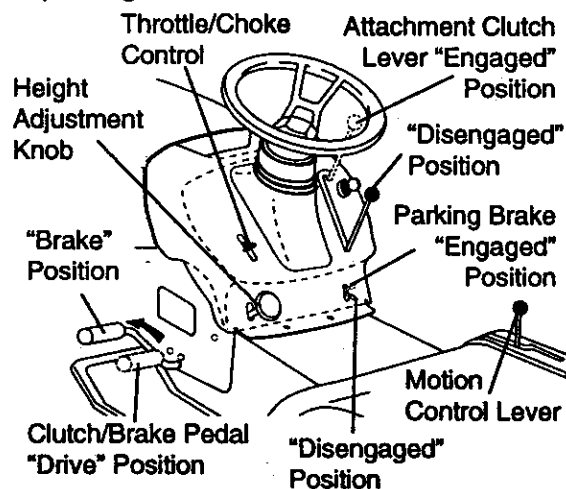

## STOPPING

### MOWER BLADES -

- To stop mower blades, move attachment clutch Lever to "DISENGAGED" position.

### GROUND DRIVE -

- To stop ground drive, depress clutch/brake pedal into full "BRAKE" position.
- Move motion control lever to neutral (N) position.

**IMPORTANT:** The motion control lever does not return to neutral (N) position when the clutch/brake pedal is depressed.

### ENGINE -

- Move throttle control to slow position.
- NOTE:** Failure to move throttle control to slow position and allowing engine to idle

before stopping may cause engine to "backfire".

- Turn ignition key to "OFF" position and remove key. Always remove key when leaving tractor to prevent unauthorized use.
- Never use choke to stop engine.

**IMPORTANT:** Leaving the ignition switch in any position other than "OFF" will cause the battery to be discharged (dead).

**NOTE:** Under certain conditions when tractor is standing idle with the engine running, hot engine exhaust gases may cause "browning" of grass. To eliminate this possibility, always stop engine when stopping tractor on grass areas.

**▲ CAUTION:** Always stop tractor completely, as described above, before leaving the operator's position, to empty grass catcher, etc.

## THROTTLE CONTROL

Always operate engine at full throttle.

- Operating engine at less than full throttle reduces the battery charging rate.
- Full throttle offers the best bagging and mower performance.

## TO MOVE FORWARD AND BACKWARD

The direction and speed of movement is controlled by the motion control lever.

- Start tractor with motion control lever in neutral (N) position.
- Release parking brake and clutch/brake pedal.
- Slowly move motion control lever to desired position.

## TO ADJUST MOWER CUTTING HEIGHT

The cutting height is controlled by turning the height adjustment knob in desired direction.

- Turn knob clockwise (C) to raise cutting height.
- Turn knob counterclockwise (O) to lower cutting height.

The cutting height range is approximately 1-1/2" to 4". The heights are measured from the ground to the blade tip with the engine not running. These heights are approximate and may vary depending upon soil conditions, height of grass and types of grass being mowed.

- The average lawn should be cut to approximately 2-1/2 inches during the cool season and to over 3 inches during hot months. For healthier and better looking lawns, mow often and after moderate growth.
- For best cutting performance, grass over 6 inches in height should be mowed twice. Make the first cut relatively high; the second to desired height.

### TO ADJUST GAUGE WHEELS

Gauge wheels are properly adjusted when they are slightly off the ground when mower is at the desired cutting height in operating position. Gauge wheels then keep the deck in proper position to help prevent scalping in most terrain conditions.

- Adjust gauge wheels with tractor on a flat level surface.
- Adjust mower to desired cutting height (See "TO ADJUST MOWER CUTTING HEIGHT" in the Operation section of this manual).
- With mower in desired height of cut position, gauge wheels should be assembled so they are slightly off the ground. Install gauge wheel in appropriate hole with shoulder bolt, 3/8 washer, and 3/8-16 locknut and tighten securely.
- Repeat for opposite side installing gauge wheel in same adjustment hole.

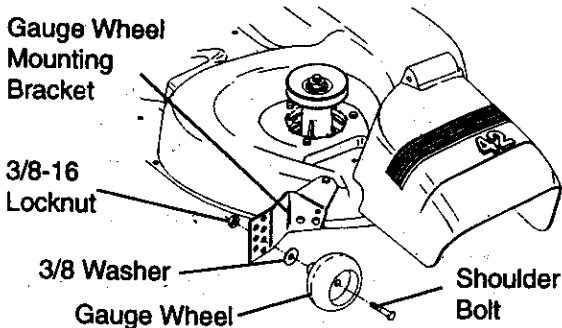

### TO OPERATE MOWER

Your tractor is equipped with an operator presence sensing switch. Any attempt by the operator to leave the seat with the engine running and the attachment clutch engaged will shut off the engine.

- Select desired height of cut.
- Lower mower with attachment lift control.
- Start mower blades by engaging attachment clutch control.
- TO STOP MOWER BLADES - disengage attachment clutch control.

**▲ CAUTION:** Do not operate the mower without either the entire grass catcher, on mowers so equipped, or the discharge guard in place.

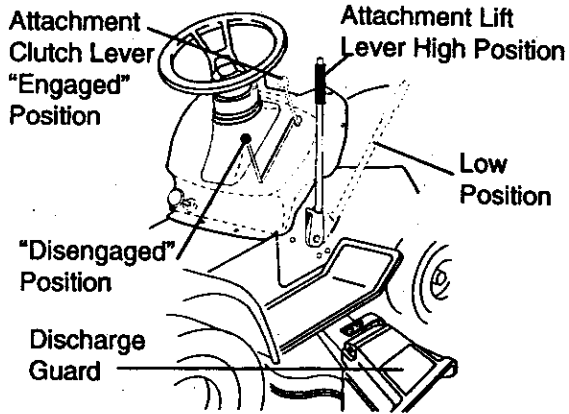

### TO OPERATE ON HILLS

**▲ CAUTION:** Do not drive up or down hills with slopes greater than 15° and do not drive across any slope. Use the slope guide provided at the back of this manual.

- Choose the slowest speed before starting up or down hills.
- Avoid stopping or changing speed on hills.
- If slowing is necessary, move throttle control lever to slower position.
- If stopping is absolutely necessary, pull clutch/brake pedal quickly to brake position and engage parking brake.
- Move motion control lever to neutral position.

**IMPORTANT:** The motion control lever does not return to neutral (N) position when the clutch/brake pedal is depressed.

- To restart movement, slowly release parking brake and clutch/brake pedal.
- Slowly move motion control lever to slowest setting.
- Make all turns slowly.

### TO TRANSPORT

When pushing or towing your tractor, be sure to disengage transmission by placing freewheel control in freewheeling position. Freewheel control is located at the rear drawbar of tractor.

- Raise attachment lift to highest position with attachment lift control.
- Pull freewheel control knob out and hold in position by inserting retainer spring into forward hole of control rod.
- Do not push or tow tractor at more than two (2) MPH.
- To reengage transmission, reverse above procedure.

**NOTE:** To protect hood from damage when transporting your tractor on a truck or a trailer, be sure hood is closed and secured to tractor. Use an appropriate means of tying hood to tractor (rope, cord, etc.).

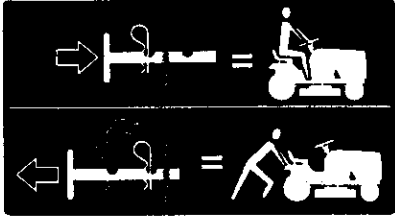

## TOWING CARTS AND OTHER ATTACHMENTS

Tow only the attachments that are recommended by and comply with specifications of the manufacturer of your tractor. Use common sense when towing. Too heavy of a load, while on a slope, is dangerous. Tires can lose traction with the ground and cause you to lose control of your tractor.

### BEFORE STARTING THE ENGINE CHECK ENGINE OIL LEVEL

- The engine in your tractor has been shipped, from the factory, already filled with summer weight oil.
- Check engine oil with tractor on level ground.
- Unthread and remove oil fill cap/dipstick; wipe oil off. Reinsert the dipstick into the tube and rest oil fill cap on the tube. Do not thread the cap onto the tube. Remove and read oil level. If necessary, add oil until "FULL" mark on dipstick is reached. Do not overfill.
- For cold weather operation you should change oil for easier starting (See "OIL VISCOSITY CHART" in the Maintenance section of this manual).
- To change engine oil, see the Maintenance section in this manual.

### ADD GASOLINE

- Fill fuel tank. Use fresh, clean, regular unleaded gasoline with a minimum of 87 octane. (Use of leaded gasoline will increase carbon and lead oxide deposits and reduce valve life). Do not mix oil with gasoline. Purchase fuel in quantities that can be used within 30 days to assure fuel freshness.

**IMPORTANT:** When operating in temperatures below 32°F(0°C), use fresh, clean winter grade gasoline to help insure good cold weather starting.

**▲WARNING:** Experience indicates that alcohol blended fuels (called gasohol or using ethanol or methanol) can attract moisture which leads to separation and formation of acids during storage. Acidic gas can damage the fuel system of an engine while in storage. To avoid engine problems, the fuel system should be emptied before storage of 30 days or longer. Drain the gas tank, start the engine and let it run until the fuel lines and carburetor are empty. Use fresh fuel next season. See Storage Instructions for additional information. Never use engine or carburetor cleaner products in the fuel tank or permanent damage may occur.

**▲CAUTION:** Fill to bottom of gas tank filler neck. Do not overfill. Wipe off any spilled oil or fuel. Do not store, spill or use gasoline near an open flame.

### TO START ENGINE

When starting the engine for the first time or if the engine has run out of fuel, it will take extra cranking time to move fuel from the tank to the engine.

- Be sure freewheel control is in the transmission engaged position.
- Sit on seat in operating position, depress clutch/brake pedal and set parking brake.
- Place motion control lever in neutral (N) position.
- Move attachment clutch to "DISENGAGED" position.
- Move throttle control to choke position.

**NOTE:** Before starting, read the warm and cold starting procedures below.

- Insert key into ignition and turn key clockwise to "START" position and release key as soon as engine starts. Do not run starter continuously for more than fifteen seconds per minute. If the engine does not start after several attempts, move throttle control to fast position, wait a few minutes and try again. If engine still does not start, move the throttle control back to the choke position and retry.

**WARM WEATHER STARTING (50° F and above)**

- When engine starts, move the throttle control to the fast position.
- The attachments and ground drive can now be used. If the engine does not accept the load, restart the engine and allow it to warm up for one minute using the choke as described above.

### COLD WEATHER STARTING ( 50° F and below)

- When engine starts, allow engine to run with the throttle control in the choke position until the engine runs roughly, then move throttle control to fast position. This may require an engine warm-up period from several seconds to several minutes, depending on the temperature.

### AUTOMATIC TRANSMISSION WARM UP

- Before driving the unit in cold weather, the transmission should be warmed up as follows:
- Be sure the tractor is on level ground.
- Place the motion control lever in neutral. Release the parking brake and let the clutch/brake slowly return to operating position.
- Allow one minute for transmission to warm up. This can be done during the engine warm up period.
- The attachments can also be used during the engine warm-up period after the transmission has been warmed up.

**NOTE:** At a high altitude (above 3000 feet) or in cold temperatures (below 32 F) the carburetor fuel mixture may need to be adjusted for best engine performance. See "TO ADJUST CARBURETOR" in the Service and Adjustments section of this manual.

### PURGE TRANSMISSION

**▲ CAUTION:** Never engage or disengage freewheel lever while the engine is running.

To ensure proper operation and performance, it is recommended that the transmission be purged before operating tractor for the first time. This procedure will remove any trapped air inside the transmission which may have developed during shipping of your tractor.

**IMPORTANT:** Should your transmission require removal for service or replacement, it should be purged after reinstallation before operating the tractor.

- Place tractor safely on level surface with engine off and parking brake set.
- Disengage transmission by placing freewheel control in freewheeling position (See "TO TRANSPORT" in this section of manual).
- Sitting in the tractor seat, start engine. After the engine is running, move throttle control to slow position. With motion control lever in neutral (N) position, slowly disengage clutch/brake pedal.
- Move motion control lever to full forward position and hold for five (5) seconds. Move lever to full reverse position and hold for five (5) seconds. Repeat this procedure three (3) times.

**NOTE:** During this procedure there will be no movement of drive wheels. The air is being removed from hydraulic drive system.

- Move motion control lever to neutral position. Shut off engine and set parking brake.
- Engage transmission by placing freewheel control in driving position (See "TO TRANSPORT" in this section of manual).
- Sitting in the tractor seat, start engine. After the engine is running, move throttle control to half (1/2) speed. With motion control lever in neutral (N) position, slowly disengage clutch/brake pedal.
- Slowly move motion control lever forward; after the tractor moves approximately five (5) feet, slowly move motion control lever to reverse position. After the tractor moves approximately five (5) feet return the motion control lever to the neutral (N) position. Repeat this procedure with the motion control lever three (3) times.
- Your tractor is now purged and ready for normal operation.



## MOWING TIPS

- Mower should be properly leveled for best mowing performance. See "TO LEVEL MOWER HOUSING" in the Service and Adjustments section of this manual.
- The left hand side of mower should be used for trimming.
- Drive so that clippings are discharged onto the area that has been cut. Have the cut area to the right of the tractor. This will result in a more even distribution of clippings and more uniform cutting.
- When mowing large areas, start by turning to the right so that clippings will discharge away from shrubs, fences, drive-ways, etc. After one or two rounds, mow in the opposite direction making left hand turns until finished.
- If grass is extremely tall, it should be mowed twice to reduce load and possible fire hazard from dried clippings. Make first cut relatively high; the second to the desired height.
- Do not mow grass when it is wet. Wet grass will plug mower and leave undesirable clumps. Allow grass to dry before mowing.
- **Always operate engine at full throttle when mowing** to assure better mowing performance and proper discharge of material. Regulate ground speed by selecting a low enough gear to give the mower the best cutting performance as well as the quality of cut desired.
- When operating attachments, select a ground speed that will suit the terrain and give best performance of the attachment being used.

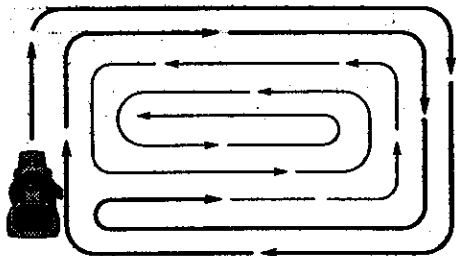

## MULCHING MOWING TIPS

**IMPORTANT:** For best performance, keep mower housing free of built-up grass and trash. Clean after each use.

- The special mulching blade will recut the grass clippings many times and reduce them in size so that as they fall onto the lawn they will disperse into the grass and not be noticed. Also, the mulched grass will biodegrade quickly to provide nutrients for the lawn. Always mulch with your highest engine (blade) speed as this will provide the best recutting action of the blades.
- Avoid cutting your lawn when it is wet. Wet grass tends to form clumps and interferes with the mulching action. The best time to mow your lawn is the early afternoon. At this time the grass has dried and the newly cut area will not be exposed to the direct sun.
- For best results, adjust the mower cutting height so that the mower cuts off only the top one-third of the grass blades. For extremely heavy mulching, reduce your width of cut on each pass and mow slowly.
- Certain types of grass and grass conditions may require that an area be mulched a second time to completely hide the clippings. When doing a second cut, mow across or perpendicular to the first cut path.
- Change your cutting pattern from week to week. Mow north to south one week then change to east to west the next week. This will help prevent matting and graining of the lawn.

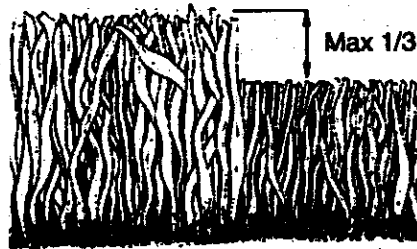

# MAINTENANCE

## CUSTOMER RESPONSIBILITIES

MAINTENANCE SCHEDULE FILL IN DATES AS YOU COMPLETE REGULAR SERVICE		SERVICE INTERVALS							SERVICE DATES				
		BEFORE EACH USE	EVERY 8 HOURS	EVERY 25 HOURS	EVERY 50 HOURS	EVERY 100 HOURS	EVERY SEASON	BEFORE STORAGE					
TRACTOR	Check Brake Operation	✓	✓										
	Check Tire Pressure	✓	✓										
	Check Operator Presence and Interlock Systems	✓											
	Check for Loose Fasteners	✓				✓ <sub>7</sub>		✓					
	Sharpen/Replace Mower Blades			✓ <sub>4</sub>									
	Lubrication Chart			✓				✓					
	Check Battery Level			✓ <sub>6</sub>									
	Clean Battery and Terminals			✓				✓					
	Check Transaxle Cooling			✓									
	Adjust Blade Belt(s) Tension					✓ <sub>5</sub>							
	Adjust Motion Drive Belt(s) Tension					✓ <sub>5</sub>							
	ENGINE	Check Engine Oil Level	✓	✓									
Change Engine Oil				✓ <sub>1,2,3</sub>			✓						
Clean Air Filter				✓ <sub>2</sub>									
Clean Air Screen				✓ <sub>2</sub>									
Inspect Muffler/Spark Arrester					✓								
Replace Oil Filter (If equipped)						✓ <sub>1,2</sub>							
Clean Engine Cooling Fins						✓ <sub>2</sub>							
Replace Spark Plug						✓	✓						
Replace Air Filter Paper Cartridge						✓ <sub>2</sub>							
Replace Fuel Filter							✓						

- 1 - Change more often when operating under a heavy load or in high ambient temperatures.    5 - If equipped with adjustable system.  
 2 - Service more often when operating in dirty or dusty conditions.    6 - Not required if equipped with maintenance-free battery.  
 3 - If equipped with oil filter, change oil every 50 hours.    7 - Tighten front axle pivot bolt to 35 ft.-lbs. maximum.  
 4 - Replace blades more often when mowing in sandy soil.    Do not overtighten.

### GENERAL RECOMMENDATIONS

The warranty on this tractor does not cover items that have been subjected to operator abuse or negligence. To receive full value from the warranty, operator must maintain tractor as instructed in this manual. Some adjustments will need to be made periodically to properly maintain your tractor. All adjustments in the Service and Adjustments section of this manual should be checked at least once each season.

- Once a year you should replace the spark plug, clean or replace air filter, and check blades and belts for wear. A new spark plug and clean air filter assure proper air-fuel mixture and help your engine run better and last longer.

### BEFORE EACH USE

- Check engine oil level.
- Check brake operation.
- Check tire pressure.
- Check operator presence and interlock systems for proper operation.
- Check for loose fasteners.

### LUBRICATION CHART

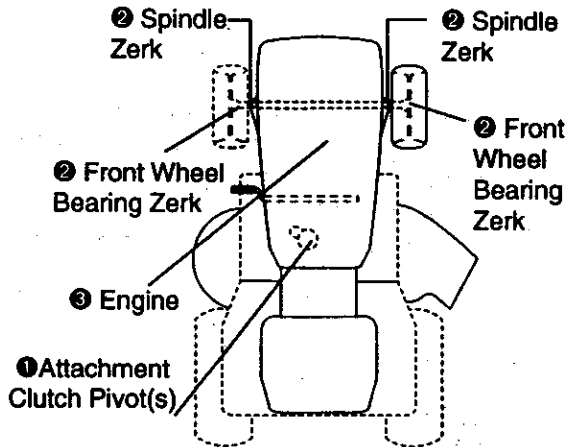

- 1 SAE 30 or 10w30 Motor OIL
- 2 General Purpose Grease
- 3 Refer to Maintenance "Engine" Section

**IMPORTANT:** Do not oil or grease the pivot points which have special nylon bearings. Viscous lubricants will attract dust and dirt that will shorten the life of the self-lubricating bearings. If you feel they must be lubricated, use only a dry, powdered graphite type lubricant sparingly.

## TRACTOR

Always observe safety rules when performing any maintenance.

### BRAKE OPERATION

If tractor requires more than six (6) feet stopping distance at high speed in highest gear, then brake must be adjusted. (See "TO ADJUST BRAKE" in the Service and Adjustments section of this manual).

### TIRES

- Maintain proper air pressure in all tires (See "PRODUCT SPECIFICATIONS" section of this manual).
- Keep tires free of gasoline, oil, or insect control chemicals which can harm rubber.
- Avoid stumps, stones, deep ruts, sharp objects and other hazards that may cause tire damage.

**NOTE:** To seal tire punctures and prevent flat tires due to slow leaks, tire sealant may be purchased from your local parts dealer. Tire sealant also prevents tire dry rot and corrosion.

### OPERATOR PRESENCE SYSTEM

Be sure that operator presence and interlock systems are working properly. If your tractor does not function as described below, repair the problem immediately.

- The engine should not start unless the clutch/brake pedal is fully depressed and attachment clutch control is in the disengaged position.
- When the engine is running, any attempt by the operator to leave the seat without first setting the parking brake should shut off the engine.
- When the engine is running and the attachment clutch is engaged, any attempt by the operator to leave the seat should shut off the engine.
- The attachment clutch should never operate unless the operator is in the seat.

### BLADE CARE

For best results mower blades must be kept sharp. Replace bent or damaged blades.

### BLADE REMOVAL

- Raise mower to highest position to allow access to blades.
- Remove hex bolt, lock washer and flat washer securing blade.
- Install new or resharpened blade with trailing edge up towards deck as shown.

**IMPORTANT:** To ensure proper assembly, center hole in blade must align with star on mandrel assembly.

- Reassemble hex bolt, lock washer and flat washer in exact order as shown.
- Tighten bolt securely (27-35 Ft. Lbs. torque).

**IMPORTANT:** Blade bolt is Grade 8 heat treated.

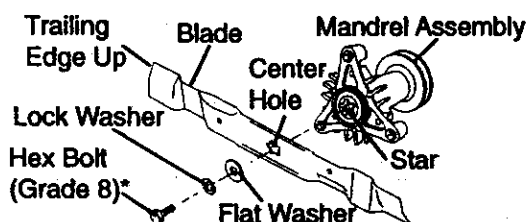

\*A Grade 8 heat treated bolt can be identified by six lines on the bolt head.

### TO SHARPEN BLADE

**NOTE:** We do not recommend sharpening blade, but if you do, be sure the blade is balanced.

Care should be taken to keep the blade balanced. An unbalanced blade will cause excessive vibration and eventual damage to mower and engine.

- The blade can be sharpened with a file or on a grinding wheel. Do not attempt to sharpen while it is on the mower.
- To check blade balance, you will need a 5/8" diameter steel bolt, pin, or a cone balancer. (When using a cone balancer, follow the instructions supplied with balancer).

**NOTE:** Do not use a nail for balancing blade. The lobes of the center hole may appear to be centered, but are not.

- Slide blade onto an unthreaded portion of the steel bolt or pin and hold the bolt or pin parallel with the ground. If blade is balanced, it should remain in a horizontal position. If either end of the blade moves downward, sharpen the heavy end until the blade is balanced.

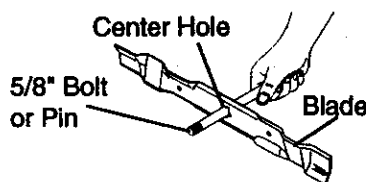

### BATTERY

Your tractor has a battery charging system which is sufficient for normal use.

However, periodic charging of the battery with an automotive charger will extend its life.

- Keep battery and terminals clean.
- Keep battery bolts tight.
- Keep small vent holes open.
- Recharge at 6-10 amperes for 1 hour.

**NOTE:** The original equipment battery on your tractor is maintenance free. Do not attempt to open or remove caps or covers. Adding or checking level of electrolyte is not necessary.

**TO CLEAN BATTERY AND TERMINALS**  
Corrosion and dirt on the battery and terminals can cause the battery to "leak" power.

- Open battery box door.
- Disconnect **BLACK** battery cable first then **RED** battery cable and remove battery from tractor.
- Rinse the battery with plain water and dry.
- Clean terminals and battery cable ends with wire brush until bright.
- Coat terminals with grease or petroleum jelly.
- Reinstall battery (See "REPLACING BATTERY" in the **SERVICE AND ADJUSTMENTS** section of this manual).

#### V-BELTS

Check V-belts for deterioration and wear after 100 hours of operation and replace if necessary. The belts are not adjustable. Replace belts if they begin to slip from wear.

#### TRANSAXLE COOLING

The transmission fan and cooling fins should be kept clean to assure proper cooling.

Do not attempt to clean fan or transmission while engine is running or while the transmission is hot.

- Inspect cooling fan to be sure fan blades are intact and clean.
- Inspect cooling fins for dirt, grass clippings and other materials. To prevent damage to seals, do not use compressed air or high pressure sprayer to clean cooling fins.

#### TRANSAXLE PUMP FLUID

The transaxle was sealed at the factory and fluid maintenance is not required for the life of the transaxle. Should the transaxle ever leak or require servicing, contact your nearest authorized service center/department.

#### ENGINE

##### LUBRICATION

Only use high quality detergent oil rated with API service classification SF, SG, or SH. Select the oil's SAE viscosity grade according to your expected operating temperature.

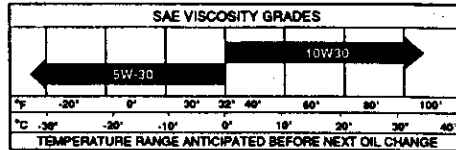

Change the oil after every 50 hours of operation or at least once a year if the tractor is not used for 50 hours in one year.

Check the crankcase oil level before starting the engine and after each eight (8) hours of operation. Tighten oil fill cap/dipstick securely each time you check the oil level.

#### TO CHANGE ENGINE OIL

Determine temperature range expected before oil change. All oil must meet API service classification SF, SG, or SH.

- Be sure tractor is on level surface.
- Oil will drain more freely when warm.
- Catch oil in a suitable container.
- Remove oil fill cap/dipstick. Be careful not to allow dirt to enter the engine when changing oil.
- Remove drain plug.
- After oil has drained completely, replace oil drain plug and tighten securely.
- Refill engine with oil through oil fill dipstick tube. Pour slowly. Do not overfill. For approximate capacity see "PRODUCT SPECIFICATIONS" section of this manual.
- Use gauge on oil fill cap/dipstick for checking level. Insert dipstick into the tube and rest the oil fill cap on the tube. Do not thread the cap onto the tube when taking reading. Keep oil at "FULL" line on dipstick. Tighten cap onto the tube securely when finished.

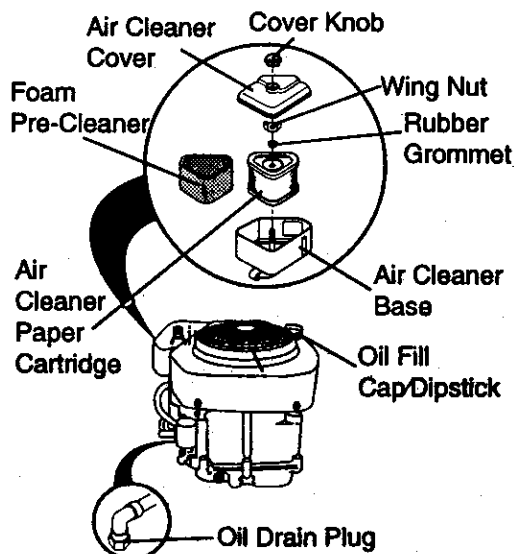

## CLEAN AIR SCREEN

Air screen must be kept free of dirt and chaff to prevent engine damage from overheating. Clean with a wire brush or compressed air to remove dirt and stubborn dried gum fibers.

## AIR FILTER

Your engine will not run properly using a dirty air filter. Clean the foam pre-cleaner after every 25 hours of operation or every season. Service paper cartridge every 100 hours of operation or every season, whichever occurs first.

Service air cleaner more often under dusty conditions.

- Remove knob and cover.
- Remove wing nut and air cleaner from base.

### TO SERVICE PRE-CLEANER

- Slide foam pre-cleaner off cartridge.
- Wash it in liquid detergent and water.
- Squeeze it dry in a clean cloth. Allow it to dry.
- Saturate it in engine oil. Wrap it in clean, absorbent cloth and squeeze to remove excess oil.

### TO SERVICE CARTRIDGE

- Replace a dirty, bent, or damaged cartridge.

**NOTE:** Do not wash the paper cartridge or use pressurized air, as this will damage the cartridge.

- Reinstall the pre-cleaner (cleaned and oiled) over the paper cartridge.
- Reassemble air cleaner, wing nut, cover and tighten knob securely.

## CLEAN AIR INTAKE/COOLING AREAS

To insure proper cooling, make sure the grass screen, cooling fins, and other external surfaces of the engine are kept clean at all times.

Every 100 hours of operation (more often under extremely dusty, dirty conditions), remove the blower housing and other cooling shrouds. Clean the cooling fins and external surfaces as necessary. Make sure the cooling shrouds are reinstalled.

**NOTE:** Operating the engine with a blocked grass screen, dirty or plugged cooling fins, and/or cooling shrouds removed will cause engine damage due to overheating.

## ENGINE OIL FILTER

Replace the engine oil filter every season

or every other oil change if the tractor is used more than 100 hours in one year.

- Drain oil from engine crankcase (See "TO CHANGE ENGINE OIL" in this section of this manual, through step remove drain plug).
- Remove oil filter and wipe off filter adapter.
- Apply a thin coating of new engine oil to the rubber gasket on replacement oil filter.
- Install replacement oil filter on filter adapter. Turn oil filter clockwise until rubber gasket contacts the filter adapter, then tighten filter an additional 1/2 turn.
- Fill crankcase with new oil (See "TO CHANGE ENGINE OIL" in this section of this manual). For approximate capacity see "PRODUCT SPECIFICATIONS" section of this manual.
- Start the engine and check for oil leaks. Correct any leaks before placing engine into full operation.

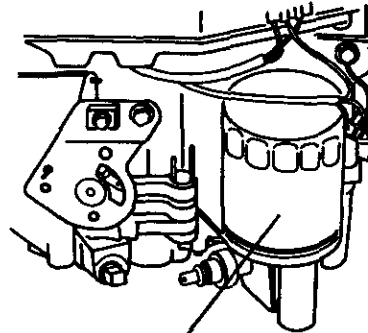

Oil Filter

## MUFFLER

Inspect and replace corroded muffler and spark arrester (if equipped) as it could create a fire hazard and/or damage.

## SPARK PLUGS

Replace spark plugs at the beginning of each mowing season or after every 100 hours of operation, whichever occurs first. Spark plug type and gap setting are shown in "PRODUCT SPECIFICATIONS" section of this manual.

## IN-LINE FUEL FILTER

The fuel filter should be replaced once each season. If fuel filter becomes clogged, obstructing fuel flow to carburetor, replacement is required.

- With engine cool, remove filter and plug fuel line sections.

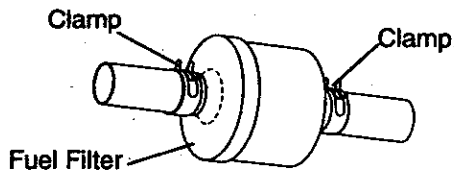

- Place new fuel filter in position in fuel line with arrow pointing towards carburetor.
- Be sure there are no fuel line leaks and clamps are properly positioned.
- Immediately wipe up any spilled gasoline.

## CLEANING

- Clean engine, battery, seat, finish, etc. of all foreign matter.
- Keep finished surfaces and wheels free of all gasoline, oil, etc.
- Protect painted surfaces with automotive type wax.

We do not recommend using a garden hose to clean your tractor unless the electrical system, muffler, air filter and carburetor are covered to keep water out. Water in engine can result in a shortened engine life.

## SERVICE AND ADJUSTMENTS

### ▲ CAUTION: Before performing any service or adjustments:

- Depress clutch/brake pedal fully and set parking brake.
- Place motion control lever in neutral (N) position.
- Place attachment clutch in "DISENGAGED" position.
- Turn ignition key "OFF" and remove key.
- Make sure the blades and all moving parts have completely stopped.
- Disconnect spark plug wire from spark plug and place wire where it cannot come in contact with plug.

## TRACTOR

### TO REMOVE MOWER

Mower will be easier to remove from the right side of tractor.

- Place attachment clutch in "DISENGAGED" position.
- Move attachment lift lever forward to lower mower to its lowest position.
- Roll belt off engine pulley.
- Disconnect clutch rod from clutch lever by removing retainer spring.
- Disconnect anti-swaybar from chassis bracket by removing retainer spring.
- Disconnect suspension arms from rear deck brackets by removing retainer springs.

- Disconnect front links from deck by removing retainer springs.
- Raise lift lever to raise suspension arms. Slide mower out from under tractor.

**IMPORTANT:** If an attachment other than the mower deck is to be mounted on the tractor, remove the front links.

### TO INSTALL MOWER

- Raise attachment lift lever to its highest position.
- Slide mower under tractor with discharge guard to right side of tractor.
- Lower lift lever to its lowest position.
- Install mower in reverse order of removal instructions.

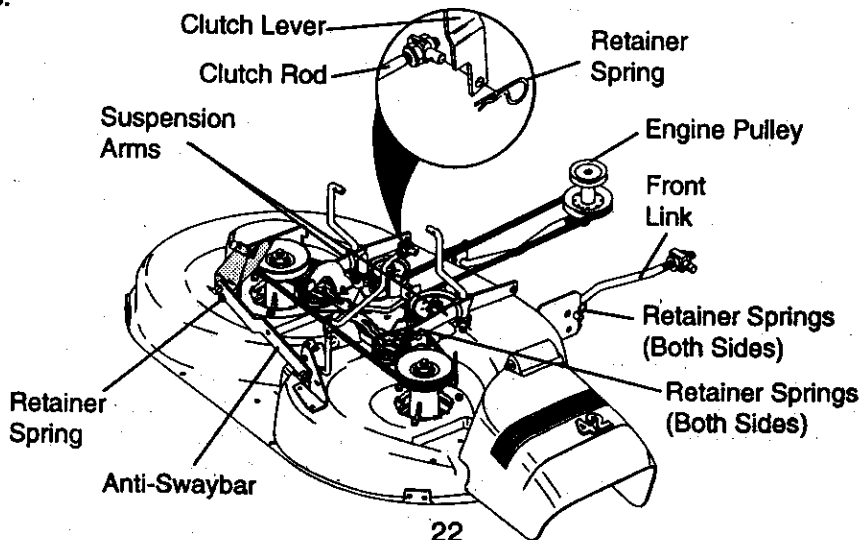

## TO LEVEL MOWER HOUSING

Adjust the mower while tractor is parked on level ground or driveway. Make sure tires are properly inflated (See "PRODUCT SPECIFICATIONS"). If tires are over or underinflated, you will not properly adjust your mower.

## SIDE-TO-SIDE ADJUSTMENT

- Raise mower to its highest position.
- At the midpoint of both sides of mower, measure height from bottom edge of mower to ground. Distance "A" on both sides of mower should be the same or within 1/4" of each other.
- If adjustment is necessary, make adjustment on one side of mower only.
- To raise one side of mower, tighten lift link adjustment nut on that side.
- To lower one side of mower, loosen lift link adjustment nut on that side.

**NOTE:** Each full turn of adjustment nut will change mower height about 1/8".

- Recheck measurements after adjusting.

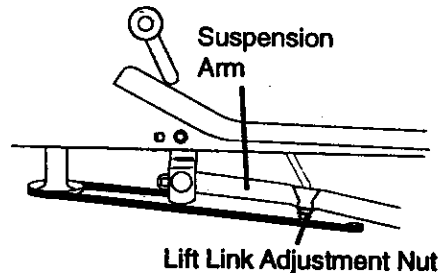
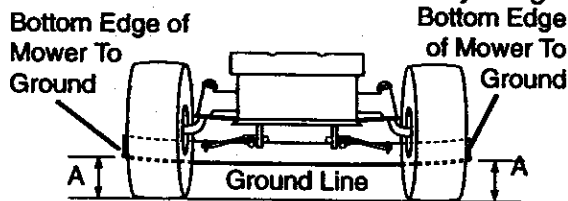

## FRONT-TO-BACK ADJUSTMENT

**IMPORTANT:** Deck must be level side-to-side. If the following front-to-back adjustment is necessary, be sure to adjust both front links equally so mower will stay level side-to-side.

To obtain the best cutting results, the mower housing should be adjusted so that the front is approximately 1/8" to 1/2" lower than the rear when the mower is in its highest position.

Check adjustment on right side of tractor. Measure distance "D" directly in front and behind the mandrel at bottom edge of mower housing as shown.

- Before making any necessary adjustments, check that both front links are equal in length. Both links should be approximately 10-3/8".

- If links are not equal in length, adjust one link to same length as other link.
- To lower front of mower loosen nut "E" on both front links an equal number of turns.
- When distance "D" is 1/8" to 1/2" lower at front than rear, tighten nuts "F" against trunnion on both front links.
- To raise front of mower, loosen nut "F" from trunnion on both front links. Tighten nut "E" on both front links an equal number of turns.
- When distance "D" is 1/8" to 1/2" lower at front than rear, tighten nut "F" against trunnion on both front links.
- Recheck side-to-side adjustment.

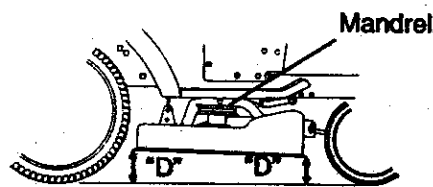

Both Front Links Should be Equal in Length

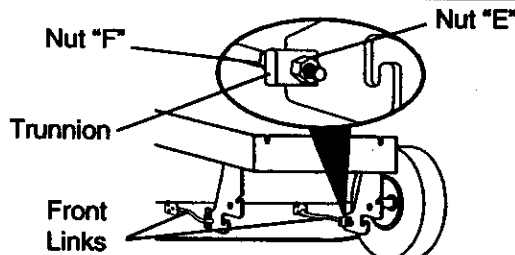
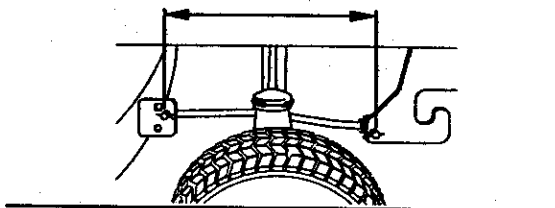

## TO REPLACE MOWER BLADE DRIVE BELT (See Illustration Next Page)

The mower blade drive belt may be replaced without tools. Park the tractor on level surface. Engage parking brake.

### BELT REMOVAL -

- Remove mower from tractor (See "TO REMOVE MOWER" in this section of this manual).
- Work belt off both mandrel pulleys and idler pulleys.
- Pull belt away from mower.

### BELT INSTALLATION -

- Install new belt in reverse order of removal.
- Make sure belt is in all pulley grooves and inside all belt guides.
- Install mower in reverse order of removal instructions

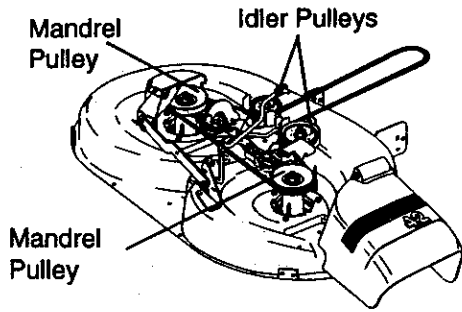

- Pull belt slack toward rear of tractor. Carefully remove belt upwards from transmission input pulley and over cooling fan blades.
- Pull belt toward front of tractor and remove downward from around engine pulley.
- Install new belt by reversing above procedure.

### TO ADJUST BRAKE

Your tractor is equipped with an adjustable brake system which is mounted on the side of the transaxle.

If tractor requires more than six (6) feet stopping distance at high speed in highest gear, then brake must be adjusted.

- Depress clutch/brake pedal and engage parking brake.
- Measure distance between brake operating arm and nut "A" on brake rod.
- If distance is other than 1-9/16", loosen jam nut and turn nut "A" until distance becomes 1-9/16". Retighten jam nut against nut "A".
- Road test tractor for proper stopping distance as stated above. Readjust if necessary. If stopping distance is still greater than six (6) feet in highest gear, further maintenance is necessary. Contact your nearest authorized service center/department.

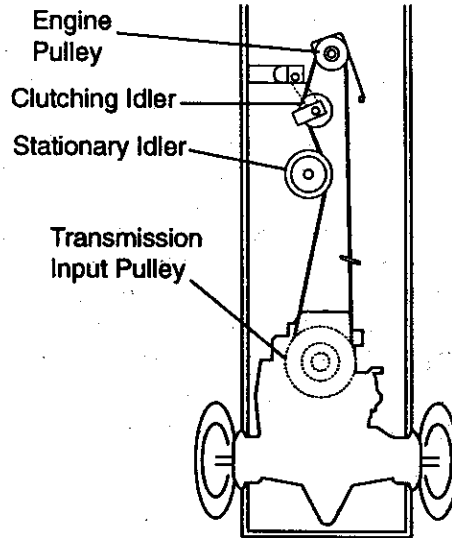

### TRANSAXLE MOTION CONTROL LEVER NEUTRAL ADJUSTMENT

The motion control lever has been preset at the factory and adjustment should not be necessary.

- Loosen adjustment bolt in front of the right rear wheel, and lightly tighten.
- Start engine and move motion control lever until tractor does not move forward or backward.
- Hold motion control lever in that position and turn engine off.
- While holding motion control lever in place, loosen the adjustment bolt.
- Move motion control lever to the neutral (N) (lock gate) position.
- Tighten adjustment bolt securely.

**NOTE:** If additional clearance is needed to get to adjustment bolt, move mower deck height to the lowest position.

After above adjustment is made, if the tractor still creeps forward or backward while motion control lever is in neutral position, follow these steps:

- Loosen the adjustment bolt.
- Move the motion control lever 1/4 to 1/2 inch in the direction it is trying to creep.
- Tighten adjustment bolt securely.
- Start engine and test.
- If tractor still creeps, repeat above steps until satisfied.

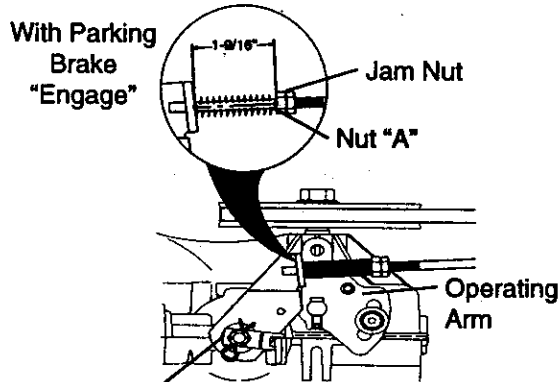

Do Not touch this nut. If further brake adjustment is necessary contact your nearest authorized service center/department

### TO REPLACE MOTION DRIVE BELT

Park the tractor on level surface. Engage parking brake. For assistance, there is a belt installation guide decal on bottom side of left footrest.

- Remove mower (See "TO REMOVE MOWER" in this section of this manual.)
- Remove belt from stationary idler and clutching idler.



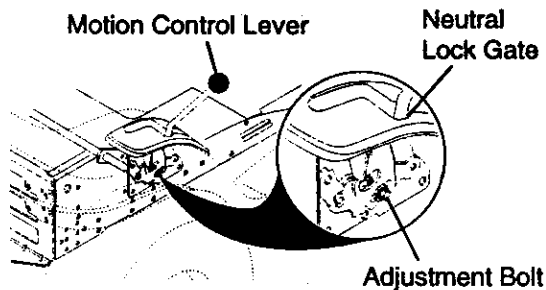

### TRANSMISSION REMOVAL/REPLACEMENT

Should your transmission require removal for service or replacement, it should be purged after reinstallation and before operating the tractor. See "PURGE TRANSMISSION" in the Operation section of this manual.

### TO ADJUST STEERING WHEEL ALIGNMENT

If steering wheel crossbars are not horizontal (left to right) when wheels are positioned straight forward, remove steering wheel and reassemble per instructions in the Assembly section of this manual.

### FRONT WHEEL TOE-IN/CAMBER

The front wheel toe-in and camber are not adjustable on your tractor. If damage has occurred to affect the front wheel toe-in or camber, contact your nearest authorized service center/department.

### TO REMOVE WHEEL FOR REPAIRS

- Block up axle securely.
- Remove axle cover, retaining ring and washers to allow wheel removal (rear wheel contains a square key - Do not lose).
- Repair tire and reassemble.
- On rear wheels only: align grooves in rear wheel hub and axle. Insert square key.
- Replace washers and snap retaining ring securely in axle groove.
- Replace axle cover.

**NOTE:** To seal tire punctures and prevent flat tires due to slow leaks, tire sealant may be purchased from your local parts dealer. Tire sealant also prevents tire dry rot and corrosion.

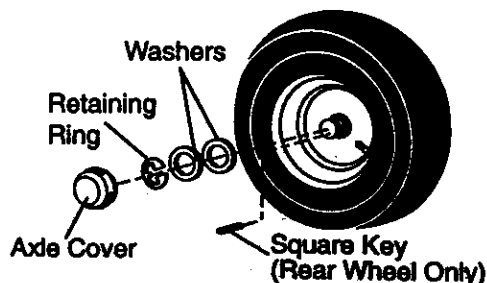

### TO START ENGINE WITH A WEAK BATTERY

**▲CAUTION:** Lead-acid batteries generate explosive gases. Keep sparks, flame and smoking materials away from batteries. Always wear eye protection when around batteries.

If your battery is too weak to start the engine, it should be recharged. (See "BATTERY" in the MAINTENANCE section of this manual).

If "jumper cables" are used for emergency starting, follow this procedure:

**IMPORTANT:** Your tractor is equipped with a 12 volt negative grounded system. The other vehicle must also be a 12 volt negative grounded system. Do not use your tractor battery to start other vehicles.

### TO ATTACH JUMPER CABLES -

- Connect each end of the RED cable to the POSITIVE (+) terminal of each battery, taking care not to short against chassis.
- Connect one end of the BLACK cable to the NEGATIVE (-) terminal of fully charged battery.
- Connect the other end of the BLACK cable to good CHASSIS GROUND, away from fuel tank and battery.

### TO REMOVE CABLES, REVERSE ORDER -

- BLACK cable first from chassis and then from the fully charged battery.
- RED cable last from both batteries.

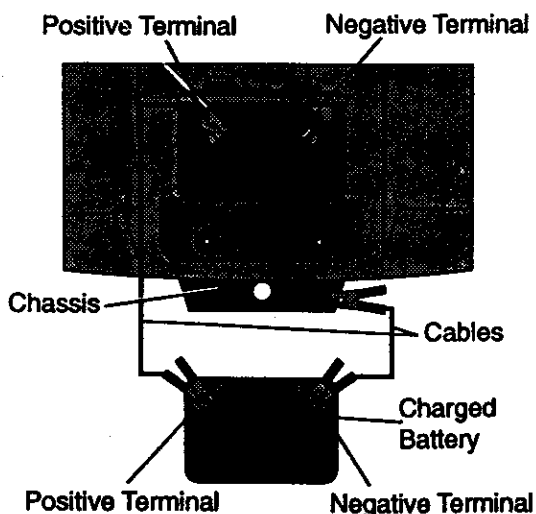

## REPLACING BATTERY

**▲CAUTION:** Do not short battery terminals by allowing a wrench or any other object to contact both terminals at the same time. Before connecting battery, remove metal bracelets, wristwatch bands, rings, etc.

Positive terminal must be connected first to prevent sparking from accidental grounding.

- Lift seat pan to raised position and open battery box door.
- Disconnect BLACK battery cable first then RED battery cable and carefully remove battery from tractor.
- Install new battery with terminals in same position as old battery.
- First connect RED battery cable to positive (+) terminal with hex bolt and keps nut as shown. Tighten securely.
- Connect BLACK grounding cable to negative (-) terminal with remaining hex bolt and keps nut. Tighten securely.
- Close battery box door.

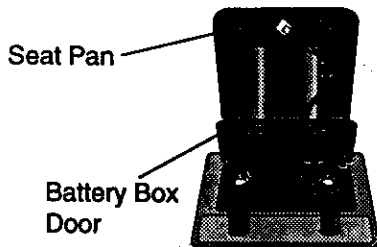
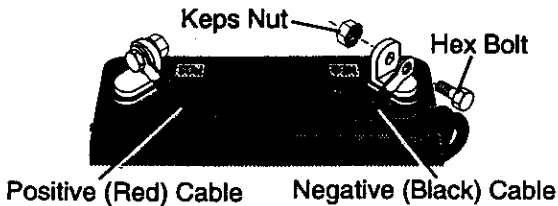

## TO REPLACE HEADLIGHT BULB

- Raise hood.
- Pull bulb holder out of the hole in the backside of the grill.
- Replace bulb in holder and push bulb holder securely back into the hole in the backside of the grill.
- Close hood.

## INTERLOCKS AND RELAYS

Loose or damaged wiring may cause your tractor to run poorly, stop running, or prevent it from starting.

- Check wiring. See electrical wiring diagram in the Repair Parts section

## TO REPLACE FUSE

Replace with 30 amp automotive-type plug-in fuse. The fuse holder is located behind the dash.

## TO REMOVE HOOD AND GRILL ASSEMBLY

- Raise hood.
- Unsnap headlight wire connector.
- Stand in front of tractor. Grasp hood at sides, tilt toward engine and lift off of tractor.
- To replace, reverse above procedures.

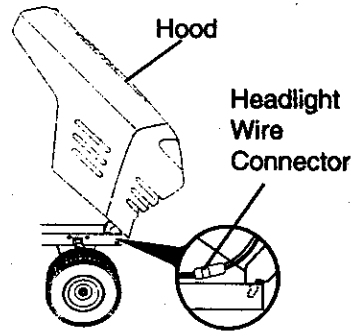

## ENGINE

Maintenance, repair, or replacement of the emission control devices and systems, which are being done at the customer's expense, may be performed by any non-road engine repair establishment or individual. Warranty repairs must be performed by an authorized engine manufacturer's service outlet.

## TO ADJUST THROTTLE CONTROL CABLE

The throttle control has been preset at the factory and adjustment should not be necessary. Check adjustment as described below before loosening cable. If adjustment is necessary, proceed as follows:

- With engine not running, move throttle control lever from slow to choke position. Slowly move lever from choke to fast position.
- Check to see if hole in throttle lever and hole in speed control bracket are aligned.
- If holes are not aligned, loosen cable clamp screw and align the holes by inserting a pencil or a 1/4" drill bit through both holes.
- Pull throttle cable up to remove slack and tighten cable clamp screw. Remove alignment pencil or drill bit.

## TO ADJUST CARBURETOR

The carburetor has been preset at the factory and adjustment should not be necessary. However, minor adjustment may be required to compensate for differences in fuel, temperature, altitude or load. If the carburetor does need adjustment, proceed as follows:

In general, turning the adjusting needles in (clockwise) decreases the supply of fuel to the engine giving a leaner fuel/air mixture. Turning the adjusting needles out (counterclockwise) increases the supply of fuel to the engine giving a richer fuel/air mixture.

**IMPORTANT:** Damage to the needles and the seats in carburetor may result if needle is turned in too tight.

**NOTE:** The carburetor on this engine is low emission. It is equipped with an idle fuel adjusting needle with a limiter cap, which allows some adjustment within the limits allowed by the cap. Do not attempt to remove the limiter cap. The limiter cap cannot be removed without breaking the adjusting needle.

- Be sure you have a clean air filter and the throttle control cable is adjusted properly (see above).
- Start engine and allow to warm for five minutes. Make adjustments with engine running and shift/motion control lever in neutral (N) position.
- **Idle speed setting** - With throttle control lever in slow position, engine should idle at 1750 RPM. If engine idles too slow or fast, turn idle speed adjusting screw in or out until correct idle is attained.
- **Idle fuel needle setting** - With throttle control lever in slow position, turn idle fuel adjustment needle in (clockwise) until engine begins to die and then turn out (counterclockwise) until engine runs rough. Turn needle to a point midway between those two positions.
- Recheck idle speed. Readjust if necessary.

## ACCELERATION TEST -

- Move throttle control lever from slow to fast position. If engine hesitates or dies, turn idle fuel adjusting needle out (counterclockwise) 1/8 turn. Repeat test and continue to adjust, if necessary, until engine accelerates smoothly.

High speed stop is factory adjusted. Do not adjust - damage may result.

**IMPORTANT:** Never tamper with the engine governor, which is factory set for proper engine speed. Overspeeding the engine above the factory high speed setting can be dangerous. If you think the engine-governed high speed needs adjusting, contact your nearest AUTHORIZED service center/department, which has proper equipment and experience to make any necessary adjustments.

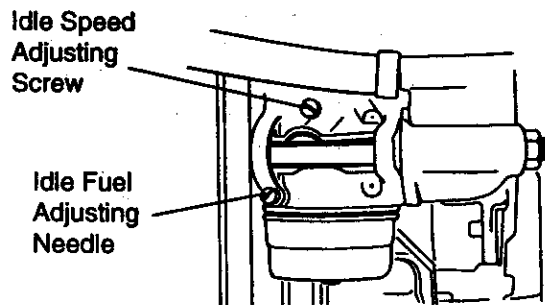
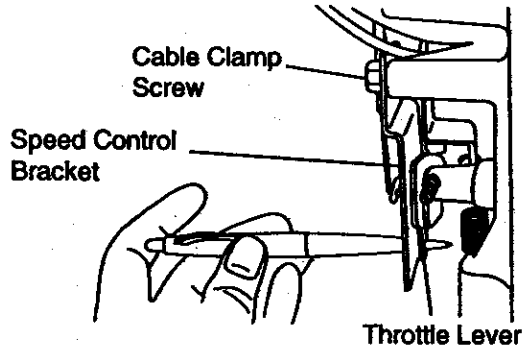

## STORAGE

Immediately prepare your tractor for storage at the end of the season or if the tractor will not be used for 30 days or more.

**▲ CAUTION:** Never store the tractor with gasoline in the tank inside a building where fumes may reach an open flame or spark. Allow the engine to cool before storing in any enclosure.

### TRACTOR

Remove mower from tractor for winter storage. This will allow you to clean it thoroughly. Remove all dirt, grease, leaves, etc. Store in a clean, dry area.

- Clean entire tractor (See "CLEANING" in the Maintenance section of this manual).
- Inspect and replace belts, if necessary (See belt replacement instructions in the Service and Adjustments section of this manual).
- Lubricate as shown in the Maintenance section of this manual.
- Be sure that all nuts, bolts and screws are securely fastened. Inspect moving parts for damage, breakage and wear. Replace if necessary.
- Touch up all rusted or chipped paint surfaces; sand lightly before painting.

### BATTERY

- Fully charge the battery for storage.
- After a period of time in storage, battery may require recharging.
- To help prevent corrosion and power leakage during long periods of storage, battery cables should be disconnected and battery cleaned thoroughly (see "TO CLEAN BATTERY AND TERMINALS" in the Maintenance section of this manual).
- After cleaning, leave cables disconnected and place cables where they cannot come in contact with battery terminals.
- If battery is removed from tractor for storage, do not store battery directly on concrete or damp surfaces.

### ENGINE

#### FUEL SYSTEM

**IMPORTANT:** It is important to prevent gum deposits from forming in essential fuel system parts such as carburetor, fuel filter, fuel hose, or tank during storage. Also,

experience indicates that alcohol blend fuels (called gasohol or using ethanol or methanol) can attract moisture which leads to separation and formation of acids during storage. Acidic gas can damage the fuel system of an engine while in storage.

- Drain the fuel tank.
- Start the engine and let it run until the fuel lines and carburetor are empty.
- Never use engine or carburetor cleaning products in the fuel tank or permanent damage may occur.
- Use fresh fuel next season.

**NOTE:** Fuel stabilizer is an acceptable alternative in minimizing the formation of fuel gum deposits during storage. Add stabilizer to gasoline in fuel tank or storage container. Always follow the mix ratio found on stabilizer container. Run engine at least 10 minutes after adding stabilizer to allow the stabilizer to reach the carburetor. Do not drain the gas tank and carburetor if using fuel stabilizer.

#### ENGINE OIL

Drain oil (with engine warm) and replace with clean engine oil. (See "ENGINE" in the Maintenance section of this manual).

#### CYLINDER(S)

- Remove spark plug(s).
- Pour one ounce of oil through spark plug hole(s) into cylinder(s).
- Turn ignition key to "START" position for a few seconds to distribute oil.
- Replace with new spark plug(s).

#### OTHER

- Do not store gasoline from one season to another.
- Replace your gasoline can if it starts to rust. Rust and/or dirt in your gasoline will cause problems.
- If possible, store your tractor indoors and cover it to give protection from dust and dirt.
- Cover your tractor with a suitable protective cover that does not retain moisture. Do not use plastic. Plastic cannot breathe, which allows condensation to form and cause your tractor to rust.

**IMPORTANT:** Never cover tractor while engine and exhaust areas are still warm.

## TROUBLESHOOTING CHART

PROBLEM	CAUSE	CORRECTION
Will not start	<ul style="list-style-type: none"> <li>• Out of fuel.</li> <li>• Engine not "CHOKED" properly.</li> <li>• Engine flooded.</li>   <li>• Bad spark plug.</li> <li>• Dirty air filter.</li> <li>• Dirty fuel filter.</li> <li>• Water in fuel.</li>   <li>• Loose or damaged wiring.</li> <li>• Carburetor out of adjustment.</li>   <li>• Engine valves out of adjustment.</li> </ul>	<ul style="list-style-type: none"> <li>• Fill fuel tank.</li> <li>• See "TO START ENGINE" in Operation section.</li> <li>• Wait several minutes before attempting to start.</li> <li>• Replace spark plug.</li> <li>• Clean/replace air filter.</li> <li>• Replace fuel filter.</li> <li>• Drain fuel tank and carburetor, refill tank with fresh gasoline and replace fuel filter.</li> <li>• Check all wiring.</li> <li>• See "To Adjust Carburetor" in Service and Adjustments section.</li> <li>• Contact an authorized service center.</li> </ul>
Hard to start	<ul style="list-style-type: none"> <li>• Dirty air filter.</li> <li>• Bad spark plug.</li> <li>• Weak or dead battery.</li> <li>• Dirty fuel filter.</li> <li>• Stale or dirty fuel.</li>   <li>• Loose or damaged wiring.</li> <li>• Carburetor out of adjustment.</li>   <li>• Engine valves out of adjustment.</li> </ul>	<ul style="list-style-type: none"> <li>• Clean/replace air filter.</li> <li>• Replace spark plug.</li> <li>• Recharge or replace battery.</li> <li>• Replace fuel filter.</li> <li>• Drain fuel tank and refill with fresh gasoline.</li> <li>• Check all wiring.</li> <li>• See "To Adjust Carburetor" in Service and Adjustments section.</li> <li>• Contact an authorized service center.</li> </ul>
Engine will not turn over	<ul style="list-style-type: none"> <li>• Clutch/brake pedal not depressed.</li> <li>• Attachment clutch is engaged.</li> <li>• Weak or dead battery.</li> <li>• Blown fuse.</li> <li>• Corroded battery terminals.</li> <li>• Loose or damaged wiring.</li> <li>• Faulty ignition switch.</li>   <li>• Faulty solenoid or starter.</li>   <li>• Faulty operator presence switch(es).</li> </ul>	<ul style="list-style-type: none"> <li>• Depress clutch/brake pedal.</li> <li>• Disengage attachment clutch.</li> <li>• Recharge or replace battery.</li> <li>• Replace fuse.</li> <li>• Clean battery terminals.</li>   <li>• Check all wiring.</li> <li>• Check/replace ignition switch.</li> <li>• Check/replace solenoid or starter.</li> <li>• Contact an authorized service center.</li> </ul>

## TROUBLESHOOTING CHART

PROBLEM	CAUSE	CORRECTION
Engine clicks but will not start	<ul style="list-style-type: none"> <li>• Weak or dead battery.</li> <li>• Corroded battery terminals.</li> <li>• Loose or damaged wiring.</li> <li>• Faulty solenoid or starter.</li> </ul>	<ul style="list-style-type: none"> <li>• Recharge or replace battery.</li> <li>• Clean battery terminals.</li> <li>• Check all wiring.</li> <li>• Check/replace solenoid or starter.</li> </ul>
Loss of power	<ul style="list-style-type: none"> <li>• Cutting too much grass/too fast.</li> <li>• Throttle in "CHOKE" position.</li> <li>• Build-up of grass, leaves and trash under mower.</li> <li>• Dirty air filter.</li> <li>• Low oil level/dirty oil.</li> <li>• Faulty spark plug.</li> <li>• Dirty fuel filter.</li> <li>• Stale or dirty fuel.</li> <li>• Water in fuel.</li> <li>• Spark plug wire loose.</li> <li>• Dirty engine air screen/fins.</li> <li>• Dirty/clogged muffler.</li> <li>• Loose or damaged wiring.</li> <li>• Carburetor out of adjustment.</li> <li>• Engine valves out of adjustment.</li> </ul>	<ul style="list-style-type: none"> <li>• Set in "Higher Cut" position/reduce speed.</li> <li>• Adjust throttle control.</li> <li>• Clean underside of mower housing.</li> <li>• Clean/replace air filter.</li> <li>• Check oil level/change oil.</li> <li>• Clean and regap or change spark plug.</li> <li>• Replace fuel filter.</li> <li>• Drain fuel tank and refill with fresh gasoline.</li> <li>• Drain fuel tank and carburetor, refill tank with fresh gasoline and replace fuel filter.</li> <li>• Connect and tighten spark plug wire.</li> <li>• Clean engine air screen/fins.</li> <li>• Clean/replace muffler.</li> <li>• Check all wiring.</li> <li>• See "To Adjust Carburetor" in Service and Adjustments section.</li> <li>• Contact an authorized service center.</li> </ul>
Excessive vibration	<ul style="list-style-type: none"> <li>• Worn, bent or loose blade.</li> <li>• Bent blade mandrel.</li> <li>• Loose/damaged part(s).</li> </ul>	<ul style="list-style-type: none"> <li>• Replace blade. Tighten blade bolt.</li> <li>• Replace blade mandrel.</li> <li>• Tighten loose part(s). Replace damaged parts.</li> </ul>
Engine continues to run when operator leaves seat with attachment clutch engaged	<ul style="list-style-type: none"> <li>• Faulty operator-safety presence control system.</li> </ul>	<ul style="list-style-type: none"> <li>• Check wiring, switches and connections. If not corrected, contact an authorized service center/department.</li> </ul>

## TROUBLESHOOTING CHART

PROBLEM	CAUSE	CORRECTION
Poor cut - uneven	<ul style="list-style-type: none"> <li>• Worn, bent or loose blade.</li> <li>• Mower deck not level.</li> <li>• Buildup of grass, leaves, and trash under mower.</li> <li>• Bent blade mandrel.</li> <li>• Clogged mower deck vent holes from buildup of grass, leaves, and trash around mandrels.</li> </ul>	<ul style="list-style-type: none"> <li>• Replace blade. Tighten blade bolt.</li> <li>• Level mower deck.</li> <li>• Clean underside of mower housing.</li> <li>• Replace blade mandrel.</li> <li>• Clean around mandrels to open vent holes.</li> </ul>
Mower blades will not rotate	<ul style="list-style-type: none"> <li>• Obstruction in clutch mechanism.</li> <li>• Worn/damaged mower drive belt.</li> <li>• Frozen idler pulley.</li> <li>• Frozen blade mandrel.</li> </ul>	<ul style="list-style-type: none"> <li>• Remove obstruction.</li> <li>• Replace mower drive belt.</li> <li>• Replace idler pulley.</li> <li>• Replace blade mandrel.</li> </ul>
Poor grass discharge	<ul style="list-style-type: none"> <li>• Engine speed too slow.</li> <li>• Travel speed too fast.</li> <li>• Wet grass.</li> <li>• Mower deck not level.</li> <li>• Low/uneven tire air pressure.</li> <li>• Worn, bent or loose blade.</li> <li>• Buildup of grass, leaves and trash under mower.</li> <li>• Mower drive belt worn.</li> <li>• Blades improperly installed.</li> <li>• Improper blades used.</li> <li>• Clogged mower deck vent holes from buildup of grass, leaves, and trash around mandrels.</li> </ul>	<ul style="list-style-type: none"> <li>• Place throttle control in "FAST" position.</li> <li>• Shift to slower speed.</li> <li>• Allow grass to dry before mowing.</li> <li>• Level mower deck.</li> <li>• Check tires for proper air pressure.</li> <li>• Replace/sharpen blade. Tighten blade bolt.</li> <li>• Clean underside of mower housing.</li> <li>• Replace mower drive belt.</li> <li>• Reinstall blades sharp edge down.</li> <li>• Replace with blades listed in this manual.</li> <li>• Clean around mandrels to open vent holes.</li> </ul>
Headlight(s) not working (if so equipped)	<ul style="list-style-type: none"> <li>• Switch is "OFF".</li> <li>• Bulb(s) burned out.</li> <li>• Faulty light switch.</li> <li>• Loose or damaged wiring.</li> <li>• Blown fuse.</li> </ul>	<ul style="list-style-type: none"> <li>• Turn switch "ON".</li> <li>• Replace bulb(s).</li> <li>• Check/replace light switch.</li> <li>• Check wiring and connections.</li> <li>• Replace fuse.</li> </ul>
Battery will not charge	<ul style="list-style-type: none"> <li>• Bad battery cell(s).</li> <li>• Poor cable connections.</li> <li>• Faulty regulator (if so equipped).</li> <li>• Faulty alternator.</li> </ul>	<ul style="list-style-type: none"> <li>• Replace battery.</li> <li>• Check/clean all connections.</li> <li>• Replace regulator.</li> <li>• Replace alternator.</li> </ul>

## TROUBLESHOOTING CHART

PROBLEM	CAUSE	CORRECTION
Loss of drive	<ul style="list-style-type: none"><li>• Freewheel control in "dis-engaged" position.</li><li>• Motion drive belt worn, damaged or broken.</li><li>• Air trapped in transmission during shipment or servicing.</li></ul>	<ul style="list-style-type: none"><li>• Place freewheel control in "engaged" position.</li><li>• Replace motion drive belt.</li><li>• Purge transmission.</li></ul>
Engine "backfires" when turning engine "OFF"	<ul style="list-style-type: none"><li>• Engine throttle control not set at "SLOW" position for 30 seconds before stopping engine.</li></ul>	<ul style="list-style-type: none"><li>• Move throttle control to "SLOW" position and allow to idle for 30 seconds before stopping engine.</li></ul>



# TRACTOR -- MODEL NUMBER 917.271080

## SCHEMATIC

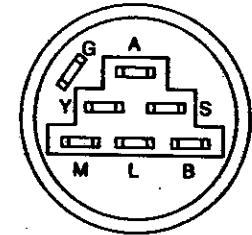
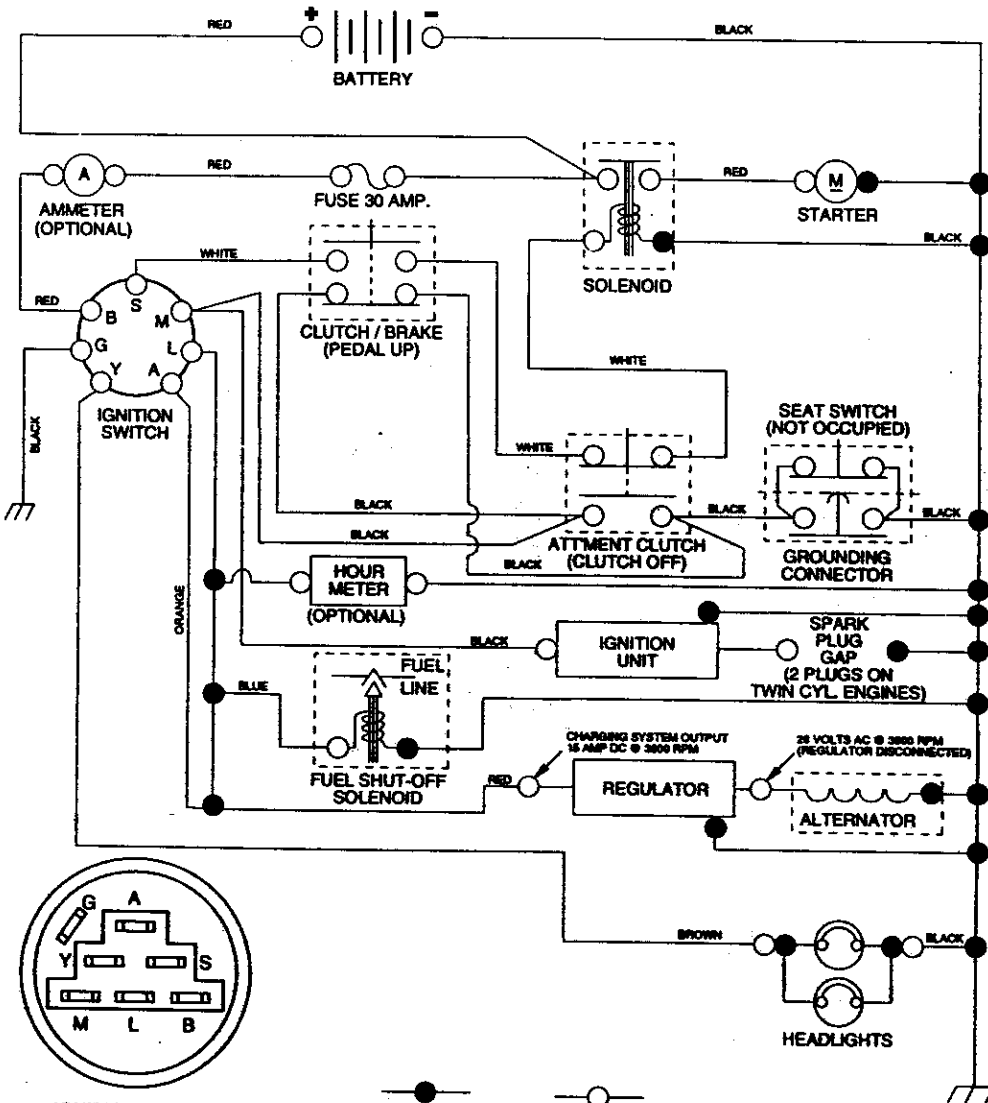

**IGNITION SWITCH**

POSITION	CIRCUIT	"MAKE"
OFF	G + M + L	NONE
RUNLIGHT	B + L	A + Y
RUN	B + L	NONE
START	B + L + S	NONE



**WIRING INSULATED CLIPS**  
 NOTE: IF WIRING INSULATED CLIPS WERE REMOVED FOR SERVICING OF UNIT, THEY SHOULD BE REPLACED TO PROPERLY SECURE YOUR WIRING.

# REPAIR PARTS

TRACTOR -- MODEL NUMBER 917.271080

## ELECTRICAL

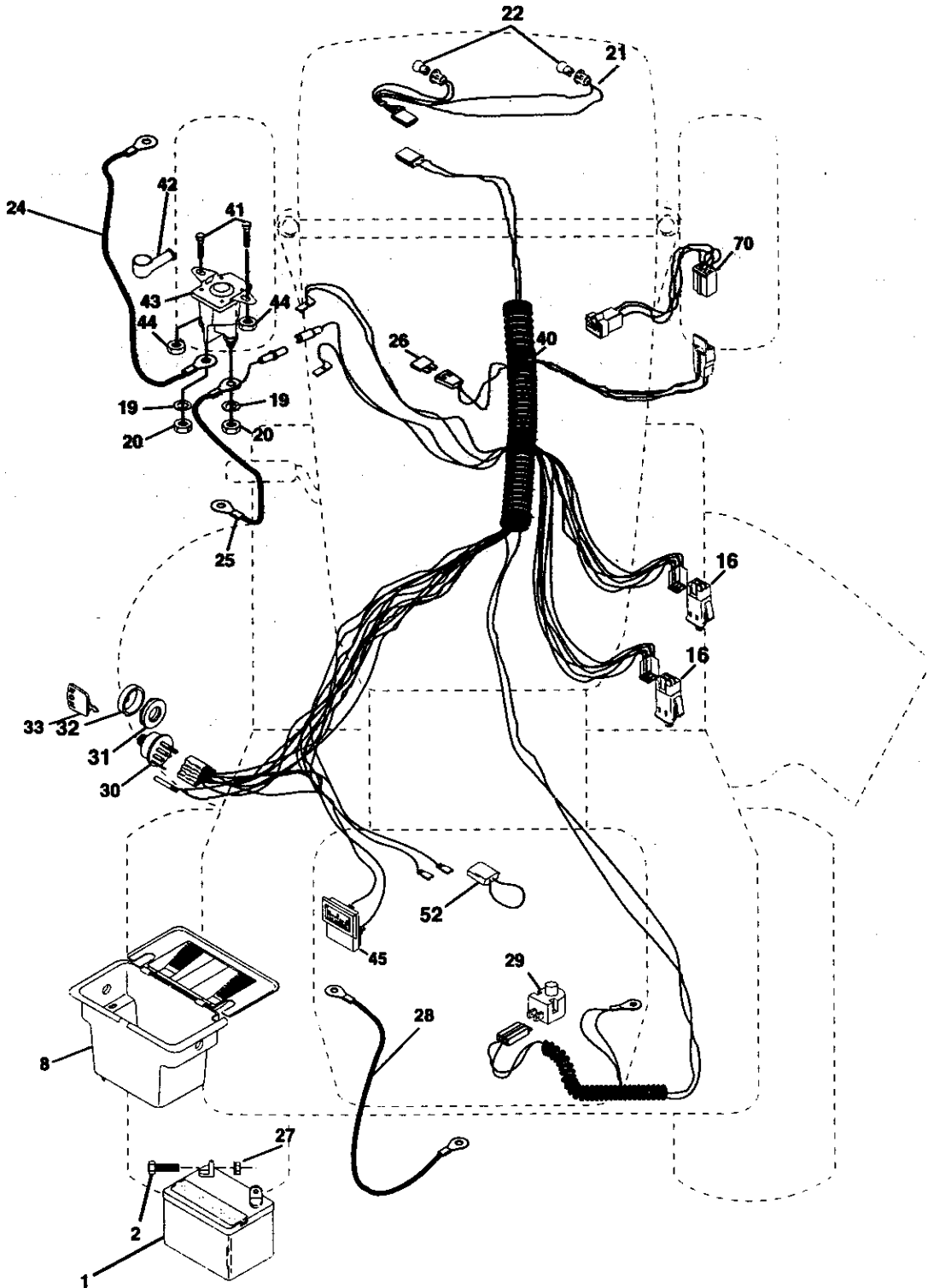

## TRACTOR - - MODEL NUMBER 917.271080

### ELECTRICAL

KEY	PART	
NO.	NO.	DESCRIPTION
1	163465	Battery 12 Volt 28 Amp
2	74760412	Bolt, Hex Head 1/4-20 unc x 3/4
8	156417	Case, Battery Mech Hinge
16	161343	Switch, Interlock N Opr/N Opn
19	STD551125	Washer, Lock
20	73350400	Nut, Hex, Jam 1/4-20 UNC
21	166182	Harness, Light Socket (Includes 4152J)
22	4152J	Bulb, Light
24	4799J	Cable, Battery, 6 Gauge, Red, 11"
25	146147	Cable, Battery, 6 Gauge, Red, W/16 Wire
26	166180	Fuse, 15Amp
27	73510400	Nut Keps Hex1/4-20 Unc
28	4207J	Cable, Ground, 6 Gauge, Black, 12"
29	160784	Switch, Plunger Normal Op Olive
30	140301	Switch, Ignition
31	124211X	Nut, Ignition
32	141226	Cover, Key Switch
33	109310X	Key, Ignition
40	166145	Harness, Ignition
41	71110408	Bolt, Hex Head, Fin. 1/4-20 x 1/2
42	131563	Cover, Terminal, Red
43	145673	Solenoid
44	73640400	Nut Keps Blk Hex 1/4-20 UNC
45	122822X	Ammeter Rectangular
52	141940	Protection Wire Loop
70	166661	Harness Engine

**NOTE:** All component dimensions given in U.S. inches  
1 inch = 25.4 mm

**TRACTOR -- MODEL NUMBER 917.271080**  
**CHASSIS AND ENCLOSURES**

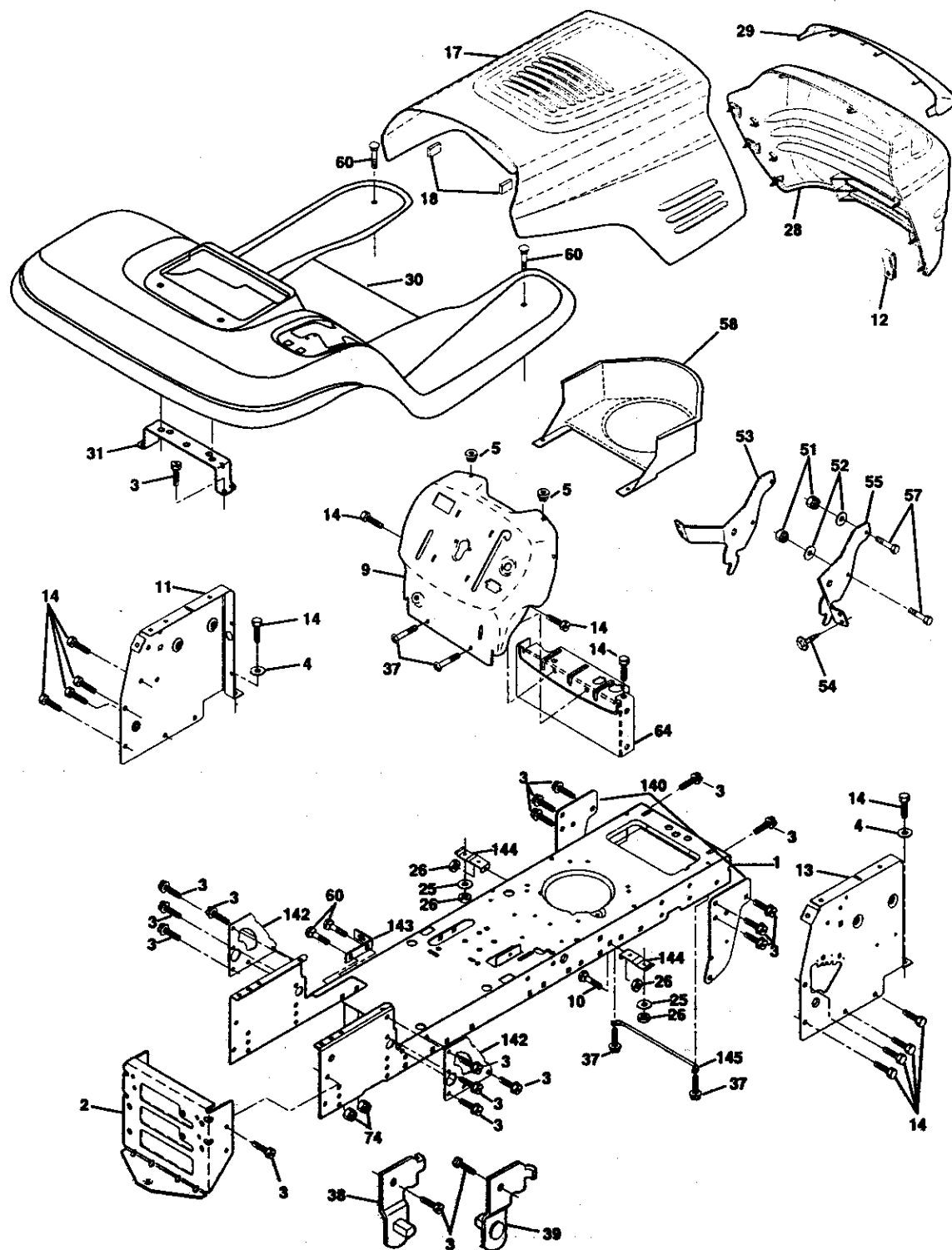

**TRACTOR - - MODEL NUMBER 917.271080**  
**CHASSIS AND ENCLOSURES**

<b>KEY NO.</b>	<b>PART NO.</b>	<b>DESCRIPTION</b>
1	165583	Chassis Stamping
2	140356	Drawbar
3	17490612	Screw, Thd. Roll. 3/8-16 x 3/4
4	19131216	Washer 13/32 x 3/4 x 16 Gauge
5	155272	Bumper Hood/Dash
9	161917X013	Dash
10	STD533710	Bolt, Carriage 3/8-16 x 1
11	155927	Panel, Dash, L.H.
12	145660	Clip Tinnerman Grille P/L
13	155936	Panel, Dash, R.H.
14	17490608	Screw Thdrol 3/8-16 x 1/2
17	144983X558	Hood Assembly
18	126938X	Bumper Hood
25	19131312	Washer 13/32 x 13/16 x 12 Gauge
26	STD541437	Nut
28	145198X558	Grille w/Clips MS-558
29	155217	Lens, Grille
30	151287X558	Fend/Ftrest Pnt STLT N HLD 558
31	139976	Bracket, Fender Support
37	17490508	Screw Thdrol 5/16-18 x 1/2 Tyt
38	139886	Pivot Bracket Assembly, L.H.
39	139887	Pivot Bracket Assembly, R.H.
51	73800400	Nut Lock w/Insert 1/4-20 UNC
52	19091416	Washer 9/32 x 7/8 x 16 Ga.
53	145201	Bracket Grille Pickoff LH
54	161464	Screw Hex Wshd 8-18 x 7/8
55	145202	Bracket Grille Pickoff RH
57	STD522507	Boit, Fin Hex 1/4-20 UNC x .75
58	150127	Duct Air Engine P/L LT
60	72140606	Bolt Rdhd Sqnk 3/8-16 UNC x 3/4
64	154798	Dash Lower STLT
74	73680600	Nut Crownlock 3/8-16 UNC
140	158418	Bracket Suspension Front
142	156095	Plate Reinforcement STLT
143	154966	Bracket Swaybar Chassis
144	154207	Bracket Pnt Footrest STLT
145	156524	RJod Pivot Chassis/Hood
--	5479J	Plug, Button

**NOTE:** All component dimensions given in U.S. inches  
1 inch = 25.4 mm

# TRACTOR -- MODEL NUMBER 917.271080

## GROUND DRIVE

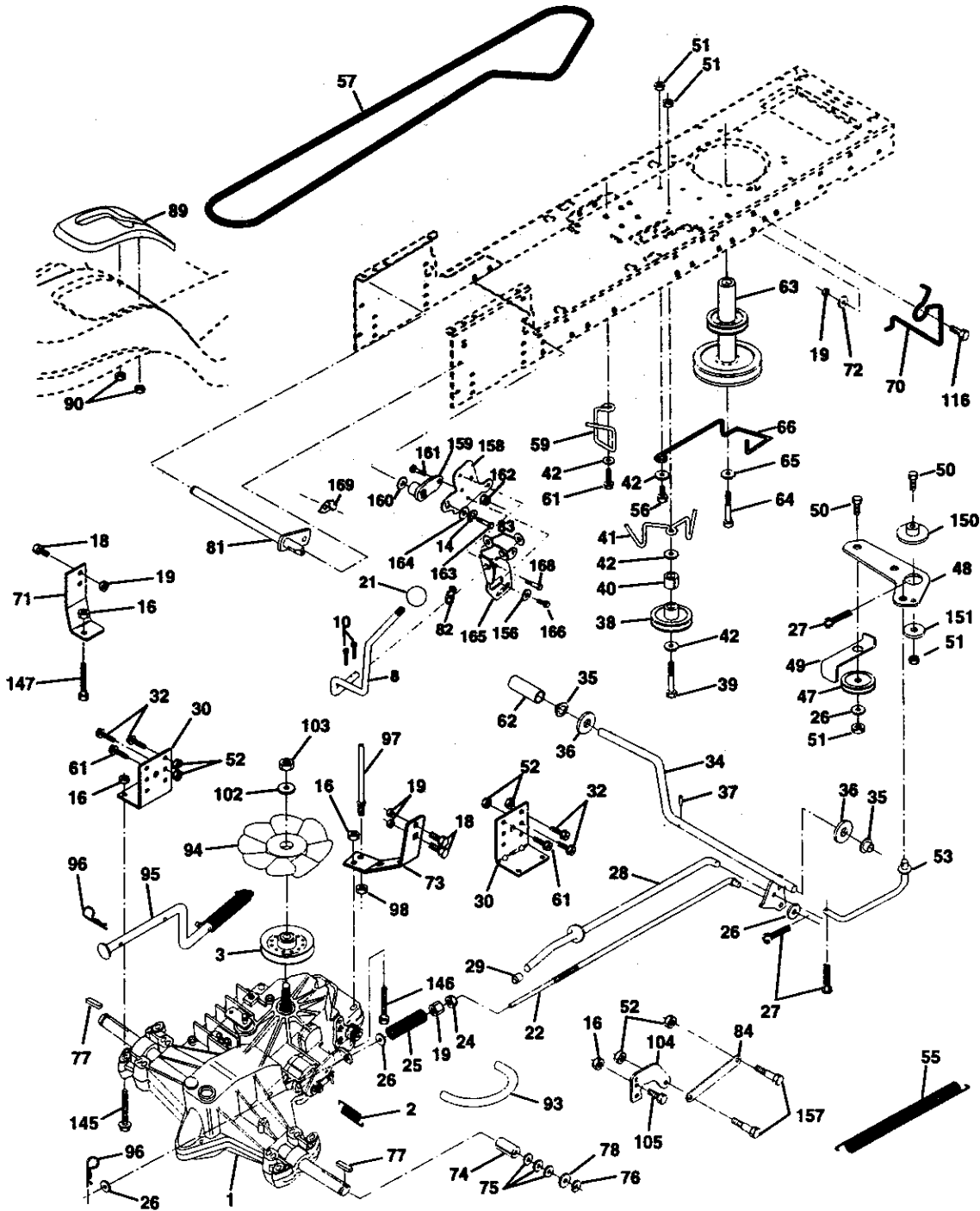

## TRACTOR - - MODEL NUMBER 917.271080

### GROUND DRIVE

KEY NO.	PART NO.	DESCRIPTION	KEY NO.	PART NO.	DESCRIPTION
1	-----	Transaxle (See Breakdown)	74	121199X	Spacer, Split
		Hydro Gear Model 319-0650	75	121749X	Washer 25/32 x 1-1/4 x 16 Gauge
2	142431	Spring, Return, Brake			E-Ring
3	143995	Pulley, Transaxle	76	STD581075	Key, Square
8	165866	Rod Shift Fender Adjust	77	123583X	Washer 25/32 x 1-5/8 x 16 Gauge
10	STD561210	Pin Cotter 1/8 x 1 CAD	78	121748X	Shaft Asm. Cross Tapered 65C 20
14	10040400	Washer Lock Hvy Helical			Spring Torsion T/A
16	STD541431	Nut Lock Hex W/Ins. 5/16-18 Unc	81	165591	Washer 17/32 x 3/4 x 16 Ga.
18	STD523710	Bolt Fin Hex 3/8-16 Unc x 1 Gr. 5	82	165711	Link Transaxle 0650 LT/YT/ST
19	STD541437	Nut Lock Hex W/Wsh 3/8-16 Unc	83	19171216	Bushing
			84	165815	Washer 21/32 x 1-1/4 x 16 Ga.
21	130564	Knob, Deluxe 1/2-13	86	71208	Ring Klip #5304-62
22	145627	Rod, Brake Hydro	87	19212016	Console, Shift
24	73350600	Nut, Hex Jam 3/8-16 Unc	88	12000008	Nut Self-Thd Wsh-hd 1/4 Zinc
25	106888X	Spring, Brake Rod	89	158388	Bolt fin Hex 5/16-18 Unc x 2.2
26	STD551037	Washer	90	124346X	Bolt Fin Hex 5/16-18 Unc x 1-1/2
27	STD561210	Pin Cotter 1/8 x 3/4 CAD.	91	74780536	Line Fuel Hydro 4"
28	145204	Rod, Parking Brake	92	74780524	Fan, Hydro 7"
29	124236X	Cap, Parking Brake	93	142564	Control Bypass Hydro 20" Tire
30	130807	Bracket, Transaxle	94	140462	Retainer Spring 1" Zinc/Cad
32	74760512	Bolt Hex Hd 5/16-18 Unc x 3/4	95	144643	Keeper Bolt Rh Hydro 0750. 18/20"
34	155071	Shaft, Foot Pedal	96	4497H	Nut Keps Hex 3/8-16 Unc
35	120183X	Bearing, Nylon	97	140469	Washer 11/32 x 3/4 x 16 Ga.
36	19211616	Washer	98	73510600	Washer Bellville .501D x 1.5C
37	1572H	Pin, Roll	100	19111216	Nut Hex Jam Toplock 1/4-20 Unf
38	131494	Pulley, Idler, Flat	102	141322	Arm, Control Hydro
39	STD523727	Bolt	103	73940800	Screw Cap Hex 5/16 x 18 x 1
40	4470J	Spacer, Split	104	140156	Bolt Fin Hex 5/16-18 Unc x 1-1/4
41	165838	Keeper, Belt Idler	105	71070516	Bolt Rdhd Sqneck 3/8-16 x 1.
42	19131312	Washer 13/32 x 13/16 x 12 Gauge	106	74780520	Washer 11/32 x 5/8 x 16 Ga.
43	19111012	Washer 11/32 x 5/8 x 12 Ga.	116	72110610	Bolt Hex FLGHD 5/16-18 x Gr
47	127783	Pulley, Idler, V-Groove	144	19111016	Bushing Bellcrank Grd Drive
48	154407	Bellcrank, Clutch	145	74490540	Washer 13/32 x 2 x 10 Ga.
49	123205X	Retainer, Belt	150	165850	Washer Srted 5/16ID x 1 .125
50	STD523715	Bolt	151	19133210	Bolt Shoulder 5/16-18 unc-2A
51	STD541437	Nut Crownlock 3/8-16 UNC	156	166002	Bracket Shift Mount
52	STD541431	Nut, Crownlock 5/16-18 Unc	157	153236	Hub Tapered Flange Shift LT
53	105710X	Link, Clutch	158	165589	Washer 29/32 x 1-1/4 x 16 Ga
55	105709X	Spring, Return, Clutch	159	165494	Bolt Rdhd Sqnk 1/4-20 x 3/4 C 5
56	STD523712	Bolt Hex 3/8-16 x 1-1/4	160	19292016	Nut Crownlock 1/4-20 Unc
57	140294	V-Belt	161	72140406	Bolt Hex Fin 1/4-20 Unc x 1 G
59	140312	Keeper, Center Span	162	73680400	Washer 5/8 x .281 x 10 Ga.
61	17490612	Screw Thdrol. 3/8-16 x 3/4 Ty. TT	163	74780416	Bracket Pivot Lever
62	8883R	Cover, Pedal	164	19091010	Screw 5/16-18 x 5/8
63	140186	Pulley, Engine	165	165623	Bolt Shoulder 5/16-18 x .561
64	71170764	Bolt Hex 7/16-20 x 4 Gr. 5	166	166880	Plate Fastening Cross Shf
65	STD551143	Washer	168	165492	STLT/CRD
66	154778	Keeper Belt Engine Hydro	169	165580	
70	134683	Keeper Belt Engine			
71	140158	Strap Torque Lh Hydro 18/20" T			
72	19132012	Washer 13/32 x 1-1/4 x 12 Gauge			
73	156347	Strap Torque Rh Hydro 18/20" T			

NOTE: All component dimensions given in U.S. inches  
1 inch = 25.4 mm

# TRACTOR -- MODEL NUMBER 917.271080

## STEERING ASSEMBLY

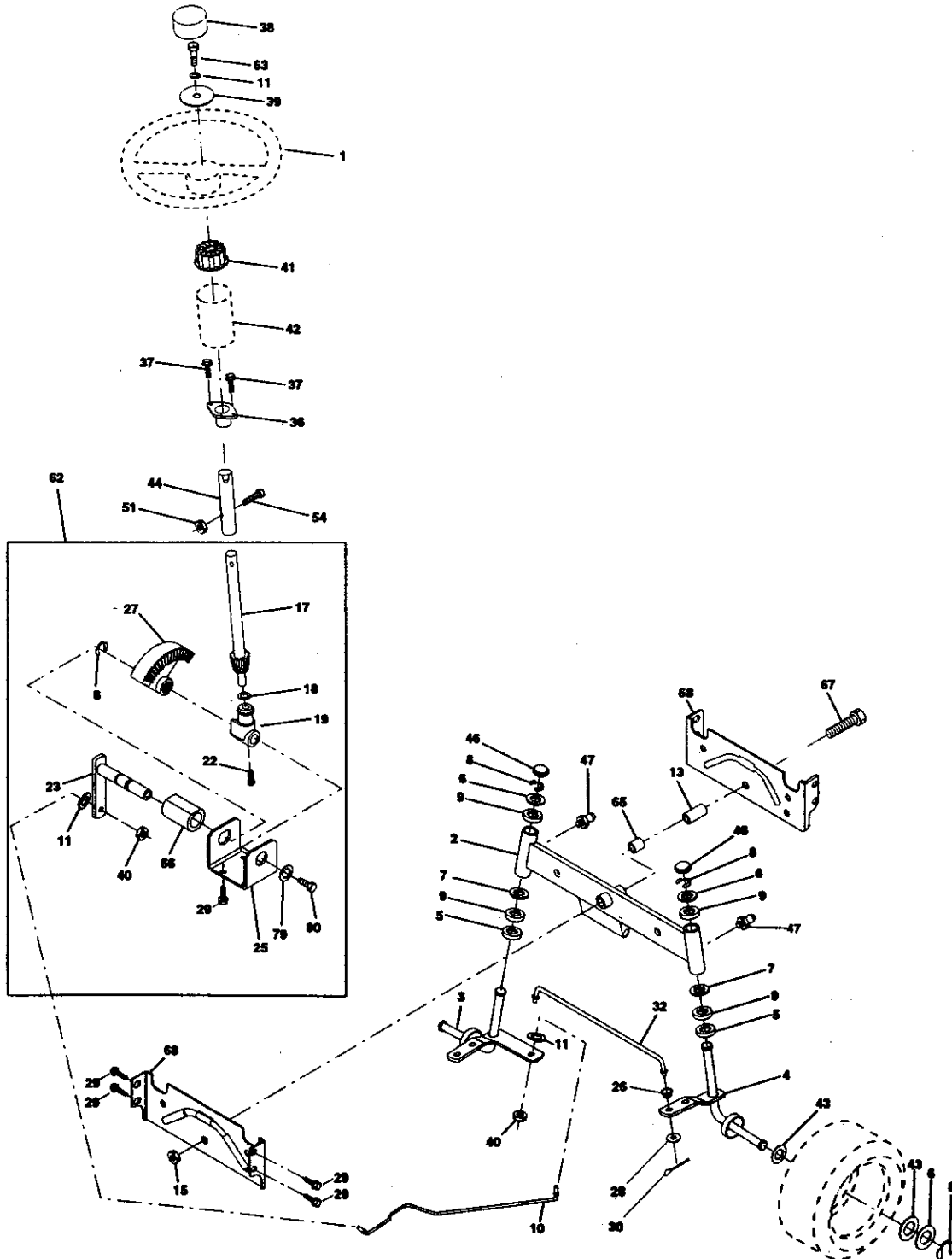



# TRACTOR - - MODEL NUMBER 917.271080

## STEERING ASSEMBLY

KEY NO.	PART NO.	DESCRIPTION
1	139768	Steering Wheel
2	154427	Axle Assembly STMP Dropped STL
3	156483	Spindle Assembly, L.H.
4	157473	Spindle Assembly, R.H.
5	6266H	Bearing, Race, Thrust, Hardened
6	121748X	Washer 25/32 x 1-5/8 x 16 Gauge
7	19272016	Washer 27/32 x 1-1/4 x 16 Gauge
8	12000029	Ring, Klip
9	3366R	Bearing, Steering Column
10	156438	Draglink Extended Stamped
11	STD551137	Washer, Lock
13	154779	Bearing Axle STLT/GT
15	73901000	Nut, Lock, Flange 5/8-11 UNC
17	156546	Shaft Assembly, Steering
18	57079	Washer, Thrust .515 x .750 x .033
19	160395	Support, Shaft
22	165857	Screw Hex Wshd Torx
23	165851	Pittman Shaft Assembly
25	154406	Bracket, Steering
26	126847X	Bushing, Link, Drag
27	136874	Gear, Sector
28	19131416	Washer 13/32 x 7/8 x 16 Gauge
29	17490612	Screw, Thd., Roll. 3/8-16 x 3/4
30	STD561210	Pin
32	130465	Rod, Tie
36	155099	Bushing, Steering
37	152927	Screw
38	139769	Insert, Steering Wheel
39	19133808	Washer 13/32 x 2-3/8 x 8 Gauge
40	STD541537	Gripco Nut
41	100711L	Adaptor, Steering Wheel
42	145054	Boot, Steering Shaft
43	121749X	Washer 25/32 x 1-1/4 x 16 Gauge
44	153720	Extension Shaft Steering LR.LT
46	121232X	Cap, Spindle
47	6855M	Fitting, Grease
51	STD541431	Nut Lock Hex w/Ins. 5/16-18 UNC
54	74780520	Bolt Fin Hex 5/16-18 UNC x 1-1/4
62	156594	Kit Steering Asm Service
63	STD523710	Bolt, Fin Hex 3/8-16 UNC x 1 Gr 5
65	154780	Spacer Axle
66	154404	Bearing Arm Pittman
67	74781044	Bolt, Fin Hex 5/8-11 UNC x 2-3/4
68	154429	Axle, Brace
79	19132012	Washer 13/32 x 1-1/4 x 12 Ga.
80	74950612	Bolt Hex Nylon 3/8-16 x 3/4

NOTE: All component dimensions given in U.S. inches  
1 inch = 25.4 mm

# TRACTOR - - MODEL NUMBER 917.271080

## ENGINE

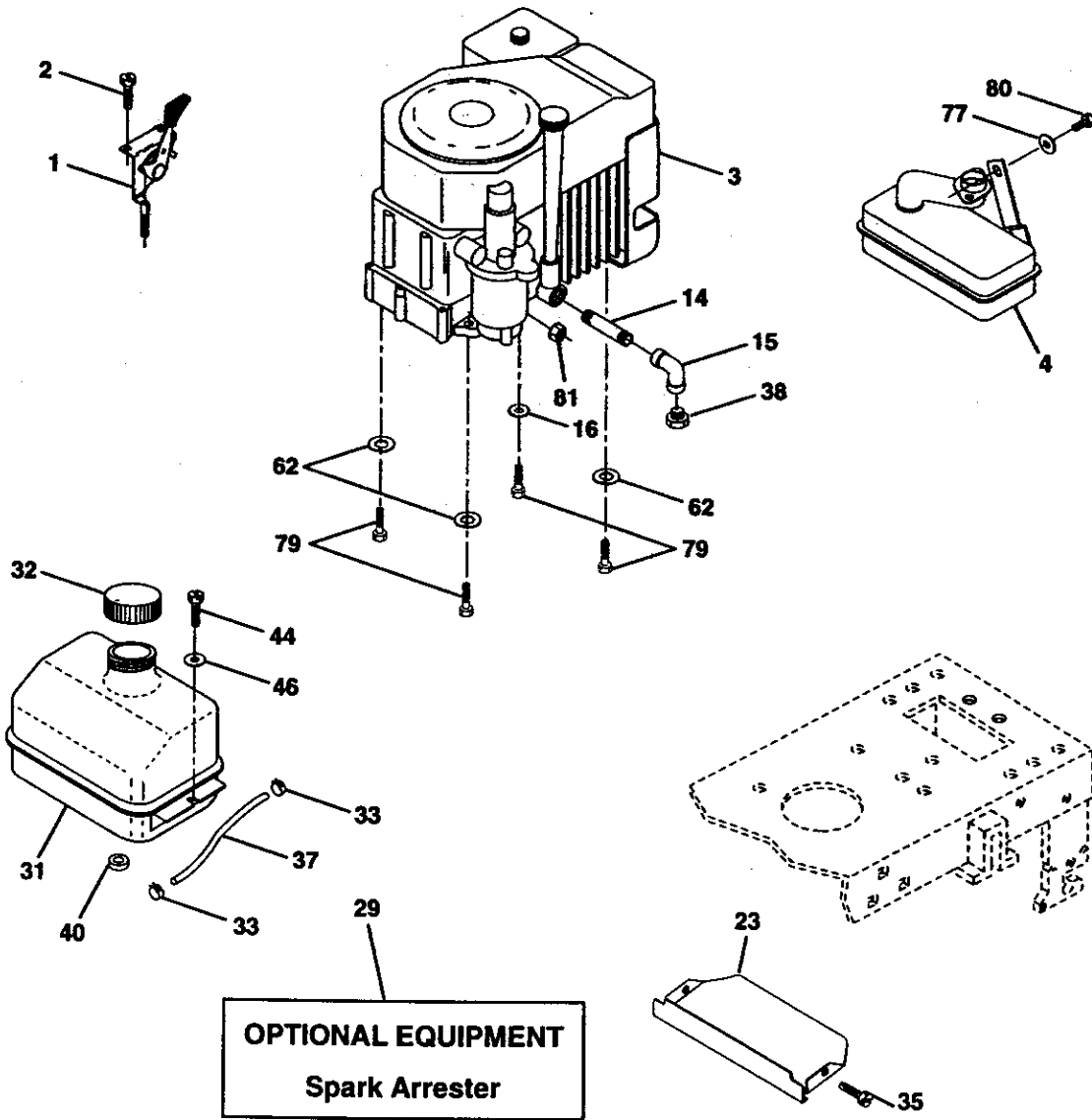

## TRACTOR -- MODEL NUMBER 917.271080

### ENGINE

KEY	PART	
NO.	NO.	DESCRIPTION
1	162156	Control, Throttle
2	17720410	Screw, Hex Head, Thread Cutting 1/4-20 x 5/8
3	-----	Engine (See Breakdown) Kohler Model CV16-43519
4	159420	Muffler
14	13280328	Nipple, Pipe 3/8 NPT x 3-1/2
15	13200300	Elbow, Standard 90°, 3/8-18 NPT
16	STD551237	Washer
23	159880	Shield Brn/Dbr Guard
29	137180	Arrestor, Spark
31	109202X	Tank, Fuel
32	158990	Cap Assembly, Fuel Sears, Vented
33	123487X	Clamp, Hose
35	17490512	Screw Thdrol 5/16-18 x 3-4 Tyl
37	137040	Line, Fuel
38	-----	Plug, Oil Drain (Order From Engine Manufacturer)
40	124028X	Bushing, Snap, Fuel Line
44	17490412	Screw, Hex Washer Head, Thd., Roll. 1/4-20 x 3/4
46	19091416	Washer 9/32 x 7/8 x 16 Gauge
62	STD551131	Washer, Lock
77	19101216	Washer 5/16 x 3/4 x 16 Ga.
79	M740108025	Bolt Hex
80	74760508	Bolt Hex Hd 5/16-18 Unc x 1/2
81	128861	Nut Flange 1/4-20 Starter Nut

**NOTE:** All component dimensions given in U.S. inches  
1 inch = 25.4 mm

# TRACTOR -- MODEL NUMBER 917.271080

## SEAT ASSEMBLY

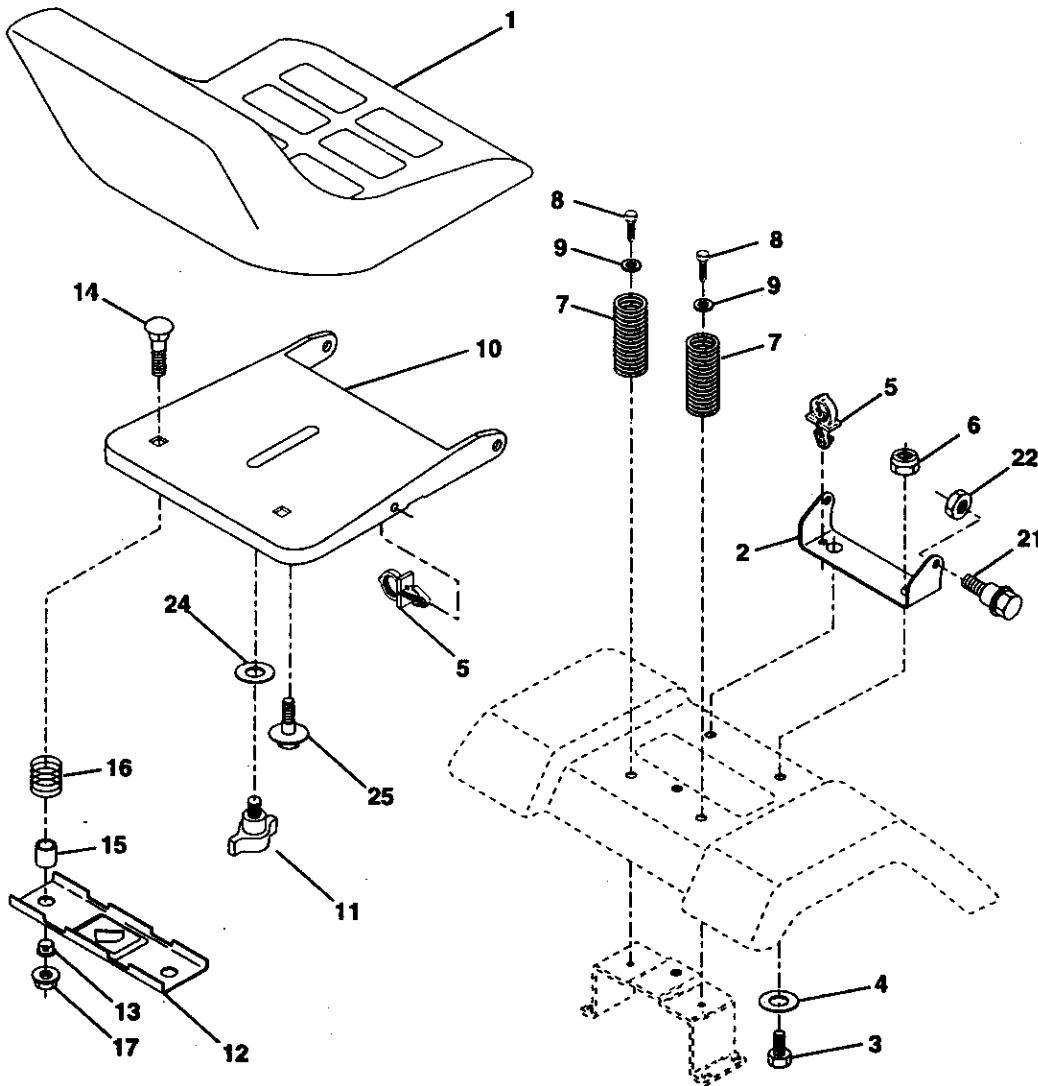

### KEY PART

NO.	NO.	DESCRIPTION
1	140123	Seat
2	140551	Bracket, Pivot, Seat
3	STD523710	Bolt
4	19131610	Washer 13/32 x 1 x 10 Gauge
5	145006	Clip, Push-In Hinged
6	STD541437	Nut
7	124181X	Spring, Seat
8	17490616	Screw, Thd., Roll. 3/8-16 x 1
9	19131614	Washer 13/32 x 1 x 14 Gauge
10	155925	Pan, Seat Emboss QCK Conn.
11	166369	Knob Seat
12	121246X	Bracket, Switch Mounting

### KEY PART

NO.	NO.	DESCRIPTION
13	121248X	Bushing, Snap
14	72050412	Bolt, Carriage 1/4-20 x 1-1/2
15	134300	Spacer, Split .28 x .88
16	121250X	Spring
17	123976X	Locknut, Flange 1/4 Grade 5
21	153236	Bolt, Shoulder 5/16-18 UNC
22	STD541431	Nut
24	19171912	Washer 17/32 x 1-3/16 x 12 Gauge
25	127018X	Bolt, Shoulder 5/16-18 x .62

NOTE: All component dimensions given in U.S. inches  
1 inch = 25.4 mm

# TRACTOR -- MODEL NUMBER 917.271080

## DECALS

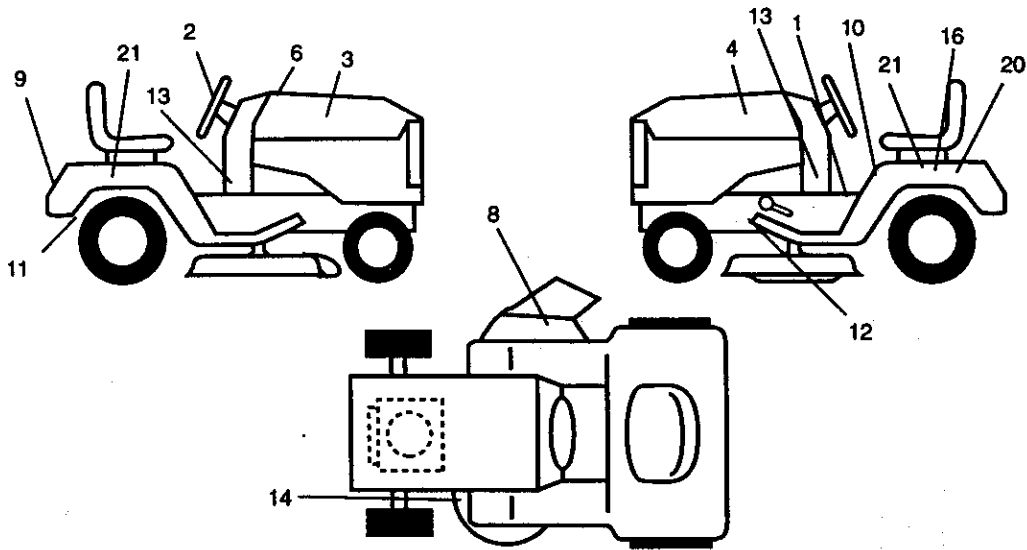

### KEY PART

NO.	NO.	DESCRIPTION
1	156811	Decal, Oper. Instr.
2	139769	Cap Wheel Steer Opp Sears
3	163200	Decal, Hood, R.H.
4	163202	Decal, Hood, L.H.
6	133644	Decal, Customer Maintenance
8	166887	Decal, Deck Mower EZ3
9	163204	Decal, Fender, Craftsman
10	156439	Decal, Fender Danger
11	142341	Decal, Drawbar Cntrl Mvt Hyd Lt
12	146046	Decal, V-Belt Drive Schematic

### KEY PART

NO.	NO.	DESCRIPTION
13	163262	Decal, Dash Pnl
14	160396	Decal, V-Belt Schematic
16	138047	Decal, Battery Diehard
20	149516	Decal, Battery Dngr/Psn Eng
21	163205	Decal, Fender Auto Sears
--	138311	Decal, Lift Handle
--	154515	Pad Footrest LH STLT
--	154516	Pad Footrest RH STLT
--	167094	Owner's Manual, English
--	167095	Owner's Manual, Spanish

## WHEELS & TIRES

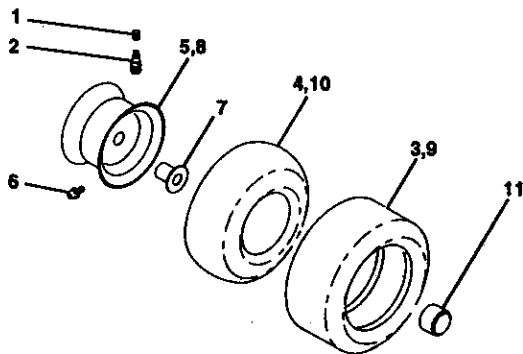

### KEY PART

NO.	NO.	DESCRIPTION
1	59192	Valve Cap, Tire
2	65139	Stem, Valve
3	106222X	Tire, Front
4	59904	Tube, Front Tire (Not Provided, Service Item Only)
5	106732X427	Rim, Front
6	278H	Fitting, Grease (Front Wheel Only)
7	9040H	Bearing, Flange (Front Wheel Only)
8	108108X427	Rim, Rear
9	122082X	Tire, Rear
10	7152J	Tube, Rear Tire (Not Provided, Service Item Only)
11	104757X	Cap, Axle
--	144334	Sealant, Tire 10 oz.

**NOTE:** All component dimensions given in U.S. inches  
1 inch = 25.4 mm

# TRACTOR -- MODEL NUMBER 917.271080

## LIFT ASSEMBLY

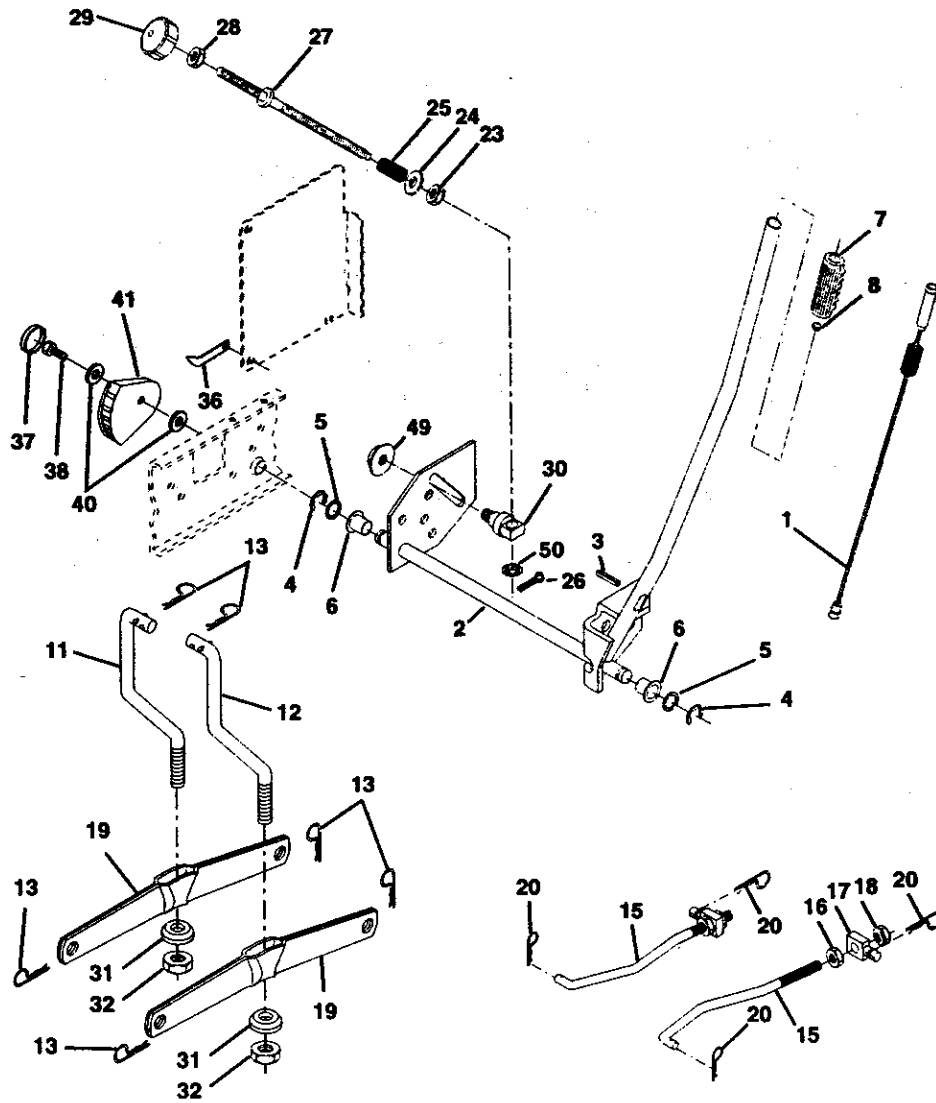

# TRACTOR - - MODEL NUMBER 917.271080

## LIFT ASSEMBLY

KEY NO.	PART NO.	DESCRIPTION
1	159460	Lift Lever Inner Wire Assembly
2	159471	Shaft Assembly, Lift
3	105767X	Pin, Groove
4	12000002	E-Ring
5	19211621	Washer 21/32 x 1 x 21 Gauge
6	120183X	Bearing, Nylon
7	125631X	Grip, Handle, Fluted
8	122365X	Button, Plunger, Red
11	139865	Link, Lift, L.H.
12	139866	Link, Lift, R.H.
13	STD624008	Retainer Spring
15	127218	Link, Front
16	73350800	Nut, Hex, Jam 1/2-13 UNC
17	130171	Trunnion
18	73800800	Locknut, Hex, with Washer Insert 1/2-13 UNC
19	139868	Arm, Suspension, Rear
20	163552	Retainer Spring
23	110807X	Nut, Special
24	19131016	Washer 13/32 x 5/8 x 16 Gauge
25	2876H	Spring
26	STD560907	Pin Cotter 3/32 x 1/2
27	126971X	Rod, Adjust, Lift
28	73350600	Nut, Hex, Jam 3/8-16 Unc
29	138057	Knob, Infinite Height Adjustment
30	150233	Trunnion, Inf Height
31	140302	Bearing, Pvt, Lift Spherical
32	73540600	Nut, Crownlock 3/8-24
36	155097	Pointer Height Indicator
37	123935X	Plug Hole Blk 1.485/1.515
38	17490512	Screw Thdrol 5/16-18 x 3/4
40	19112410	Washer 11/32 x 1-1/2 x 10 Ga.
41	155098	Indicator Height Stlt
49	145212	Nut Hex Flange Lock
50	110452X	Nut Push Phos & Oil

NOTE: All component dimensions given in U.S. inches  
1 inch = 25.4 mm

# TRACTOR -- MODEL NUMBER 917.271080

## MOWER DECK

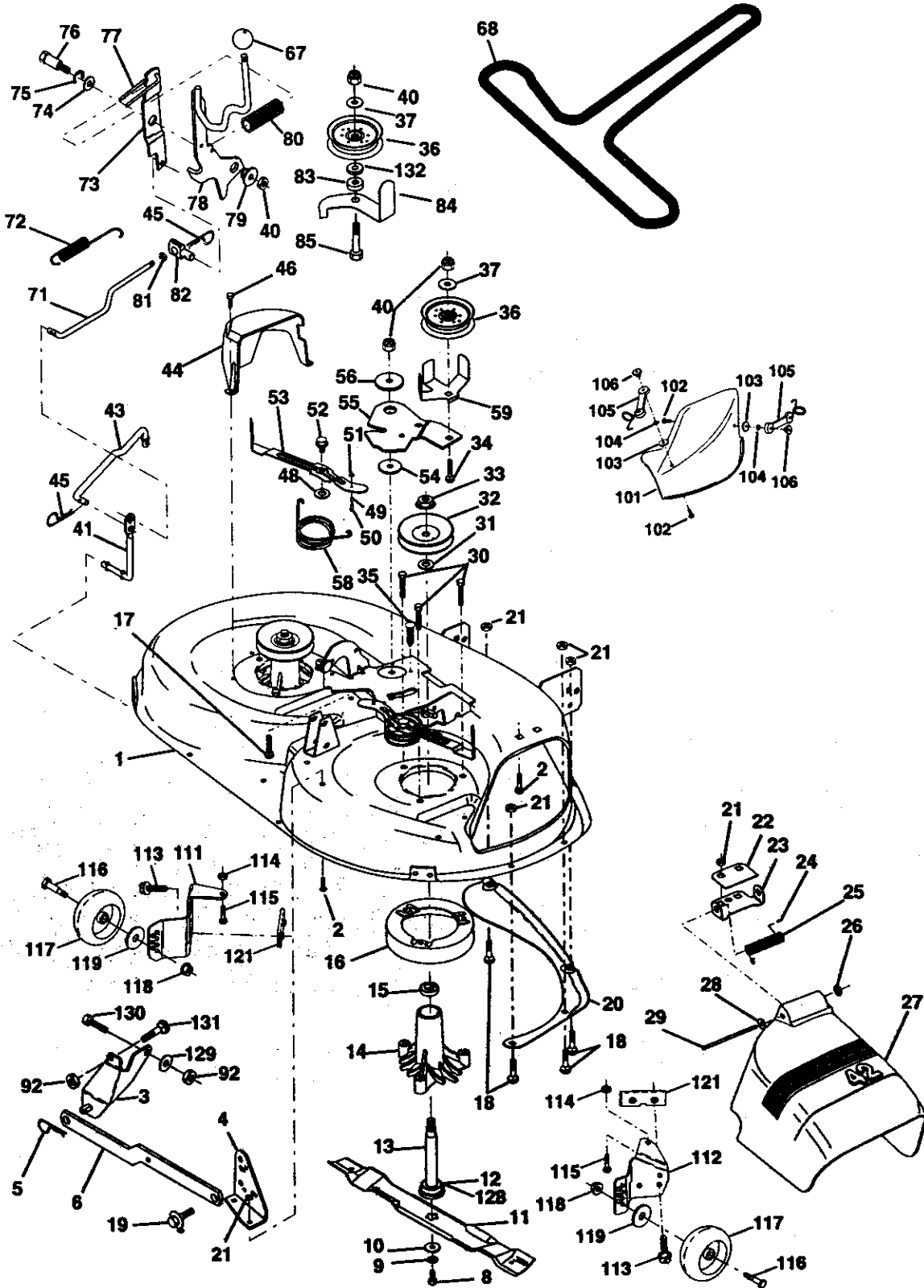



## TRACTOR - - MODEL NUMBER 917.271080

### MOWER DECK

#### KEY PART

NO.	NO.	DESCRIPTION
1	144393	Mower Housing
2	STD533107	Bolt
3	138017	Bracket Assembly, Sway Bar, Front
4	138440	Bracket Assembly, Sway Bar
5	STD624008	Retainer Spring
6	130832	Arm, Suspension, Rear
8	850857	Bolt, Hex 3/8-24 x 1.25 Grade 8
9	STD551137	Washer, Lock
10	140296	Washer, Hardened
11	134149	Blade, Mulching
12	129895	Bearing, Ball
13	137645	Shaft Assembly, Mandrel, Vented (Includes Key Number 6)
14	128774	Housing, Mandrel, Vented
15	110485X	Bearing, Ball, Mandrel
16	140329	Stripper, Vented Mower Deck
17	72110610	Bolt, Carriage 3/8-16 x 1-1/4
18	72140505	Bolt, Carriage 5/16-18 x 5/8
19	132827	Bolt, Shoulder
20	159770	Baffle, Vortex
21	STD541431	Nut Crownlock 5/16-18 UNC
22	134753	Stiffener Bracket
23	131267	Bracket, Deflector
24	105304X	Cap, Sleeve
25	123713X	Spring, Torsion, Deflector
26	110452X	Nut, Push
27	130968	Shield, Deflector
28	19111016	Washer 11/32 x 5/8 x 16 Gauge
29	131491	Rod, Hinge
30	157722	Screw Thd Rolling Wase Head
31	129963	Washer, Spacer
32	153535	Pulley, Mandrel
33	137266	Nut, Toplock, Flanged
34	STD533717	Bolt
35	133835	Fastner, Christmas Tree
36	131494	Pulley, Idler, Flat
37	19131316	Washer 13/32 x 13/16 x 16 Gauge
40	STD541437	Nut Crownlock 3/8-16 UNC
41	133551	Rod, Pivot, with Nibs
43	140083	Rod, Clutch, Secondary, with Nibs
44	140088	Guard, Mandrel, L.H.
45	STD624003	Retainer
46	137729	Screw, Thd. Roll 1/4-20 x 5/8
48	133944	Washer, Hardened
49	155066	Roller Assembly, Cam Follower
50	131340	Bolt, Shoulder #10-24 Grade 5
51	STD541410	Locknut
52	139888	Bolt, Shoulder 5/16-18 UNC
53	131845X900	Arm Assembly, Pad, Brake
54	133943	Washer, Hardened
55	155046	Arm, Idler
56	122052X	Spacer, Retainer

#### KEY PART

NO.	NO.	DESCRIPTION
58	140086	Spring, Torsion Brakes
59	141043	Guard, TUV Idler
67	162113	Knob Custom Oval
68	144200	V-Belt
71	142427	Rod, Clutch, Primary, with Nibs
72	131870	Spring, Return
73	127847	Arm, Clutch, Secondary
74	121748X	Washer 25/32 x 1-5/8 x 16 Gauge
75	12000029	Ring, Klip
76	128903	Bolt, Shoulder 3/8-16 UNC x 1.44
77	127845	Keeper, Spring
78	160570	Lever Asm. Clutch Pri P/L
79	127498	Bushing, Large, Brass
80	153701	Spring, Mower Clutch
81	73350600	Nut, Hex Jam 3/8-16 Unc
82	142028	Trunnion, Adj.
83	120958X	Washer Sintered
84	156084	Keeper Belt Idler Fixed
85	72140618	Bolt Carriage 3/8-16 x 2-1/4
92	STD541437	Nut
101	136420	Mulcher Cover
102	71161010	Screw
103	19061216	Washer #10
104	STD551110	Washer, Lock
105	160793	Latch Assembly, Bagger
106	2029J	Nut, Weld
111	155197	Bracket, Gauge, Wheel L.H.
112	155198	Bracket, Gauge, Wheel R.H.
113	17490512	Screw Thdrol 5/16-18 x 3/4
114	73510500	Nut, Hex, Keps 5/16-18 UNC
115	72110504	Bolt, Carriage 5/16 UNC x 1/2
116	4898H	Bolt, Shoulder
117	165746	Wheel, Gauge
118	73930600	Nut, Centerlock 3/8-16
119	19121414	Washer 3/8 x 7/8 x 14 Gauge
121	143723	Bracket
128	153390	Washer Felt
129	19131312	Washer 13/32 x 13/16 x 12 Ga.
130	STD523710	Bolt, Fin Hex 3/8-16 UNC x 1 Gr. 5
131	STD533710	Bolt, RDHD SQNK 3/8-16 UNC x 1
132	19132203	Spacer Washer 13/32 I.D. x 1-3/8 O.D. x 1/4
141	6266H	Washer Thrust .75 x 1.230
--	130794	Mandrel Assembly (Includes Key Numbers 8-10, 12-15, 31 and 32)
--	145411	Mower Deck, Complete (Standard Deck, Order Separately Mulcher Plate and Gauge Wheel Components, Key Nos. 101-108 and 111-121)

**NOTE: All component dimensions given in U.S.inches  
1 inch = 25.4 mm**

**TRACTOR - - MODEL NUMBER 917.271080**  
**HYDRO GEAR TRANSAXLE - - MODEL NUMBER 319-0650**

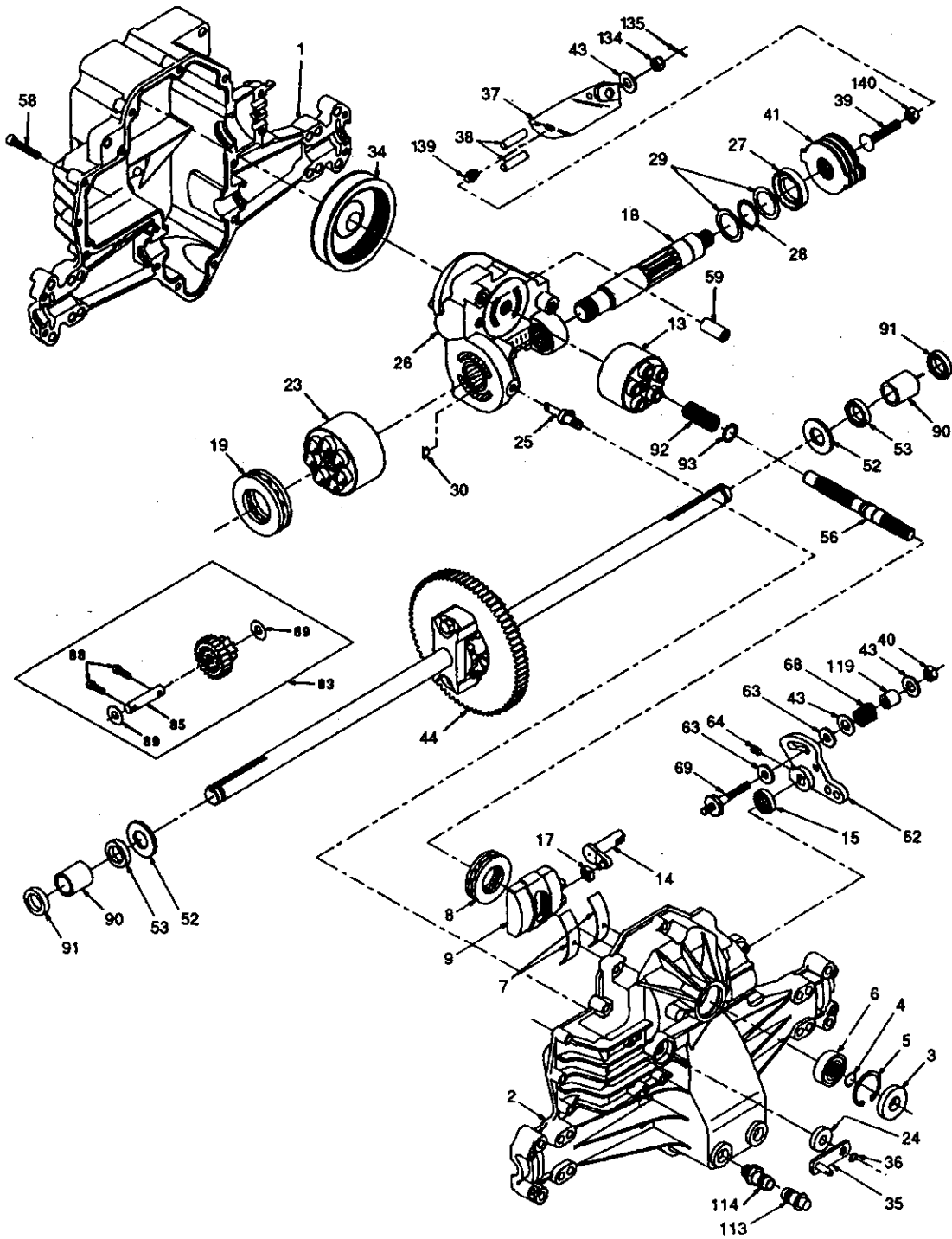

**TRACTOR - - MODEL NUMBER 917.271080**  
**HYDRO GEAR TRANSAXLE - - MODEL NUMBER 319-0650**

<b>KEY NO.</b>	<b>PART NO.</b>	<b>DESCRIPTION</b>	<b>KEY NO.</b>	<b>PART NO.</b>	<b>DESCRIPTION</b>
1	142930	Housing, Lower	43	142884	Washer 7/16 x 7/8 x .060
2	142931	Assembly, Upper Housing	44	150829	Differential Assembly
3	142932	Seal, Lip	52	142991	Washer 3/4 x 1.5 x .13
4	142928	Ring, Wire Retaining	53	142961	Seal .75 x 1.25 x .250
5	142933	Ring, Retaining	56	142963	Shaft, Input
6	142934	Bearing, Shaft Ball	58	142964	Bolt 1/4-20 x 1.38
7	142935	Bearing, Cradle	59	142965	Pin .5 OD x .43 ID x .750
8	150771	Bearing, Thrust 30 x 52 x 13	62	142966	Arm, Control
9	142937	Swashplate, Variable	63	142967	Puck, Dampener
13	142938	Block, Cylinder Assembly	64	142920	Set Screw
14	142939	Arm, Trunnion	68	142969	Spring
15	142940	Seal, Lip	69	144610	Stud 5/16-24
17	142941	Guide, Slot	83	142971	Jackshaft Assembly
18	150772	Shaft, Motor	85	150806	Jackshaft
19	150773	Bearing, Thrust 42 x 68 x 16	88	142973	Screw, Cap
23	142944	Block, Cylinder Assembly	89	142974	Washer 7/16 x 1 x 1/2
24	142945	Seal, Lip 10 x 25 x 7	90	142975	Sleeve Bearing
25	142946	Actuator, Bypass	91	142976	Seal, Wiper
26	150774	Center Section Assembly Kit	92	142977	Spring, Block
27	142948	Seal, Lip 26 x 42 x 8	93	142978	Washer, Block Thrust
28	142949	Ring, Retaining	113	142917	Cap, Vent Assembly
29	142950	Washer 26 x 35 x 1	114	142918	Fitting, O-Ring Assembly
30	150787	Plate, Bypass	119	142980	Spacer
34	142951	Oil Filter Element	134	144607	Nut, Castle 5/16-24
35	142952	Arm, Bypass	135	144608	Pin, Cotter
36	142953	Ring, Retaining	139	150775	Spring, Compression
37	142954	Arm, Actuating	140	150776	Nut, Hex 5/16-24
38	142955	Pin, Actuating			
39	150777	Bolt 5/16-24 x 1-3/4			
40	150778	Locknut, Hex 5/16-24 UNJC			
41	142958	Brake Rotor/Stator Kit			

**NOTE:** All component dimensions given in U.S. inches  
1 inch = 25.4 mm

**TRACTOR - - MODEL NUMBER 917.271080**  
**KOHLER ENGINE-MODEL NUMBER CV16S, TYPE NUMBER PS-43519**

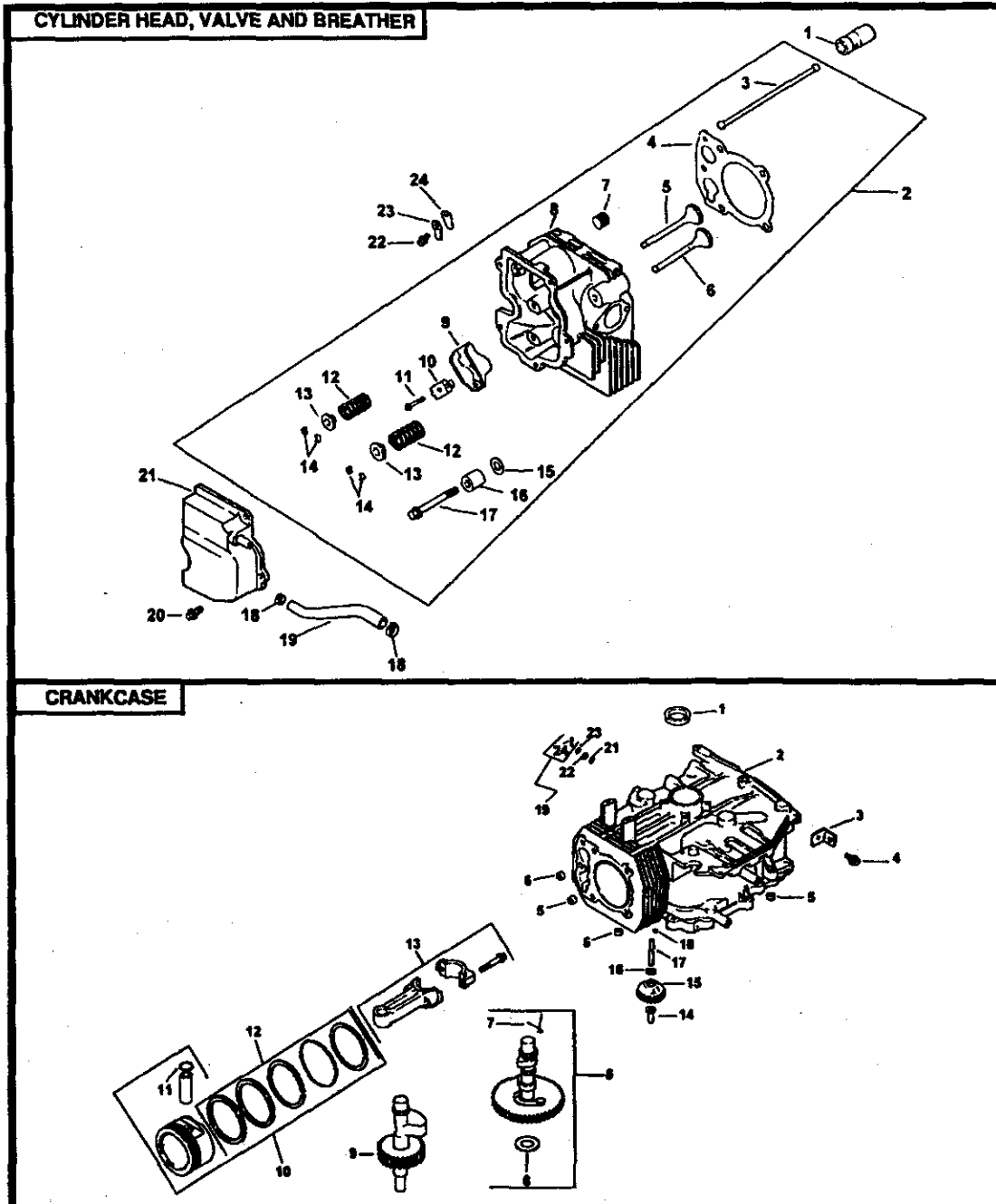

**TRACTOR - - MODEL NUMBER 917.271080**  
**KOHLER ENGINE-MODEL NUMBER CV16S, TYPE NUMBER PS-43519**

**CYLINDER HEAD/VALVE/BREATHER**

**CRANKCASE**

KEY NO.	PART NO.	DESCRIPTION	KEY NO.	PART NO.	DESCRIPTION
1	25-351-01	Lifter, valve (2)	1	12-032-03	Seal, crankshaft
2	12-755-81	Kit, cylinder head (Includes 3-17)	2	Block, cylinder (Use Short Block 12 522 18)	
	12-041-01	Carburetor gasket(2)	3	12-445-02	Strap, lifting
	12-041-02	Air cleaner base gasket	4	M-0839025	Screw, hex. flange M8x1.25x25
	12-041-03	Exhaust manifold gasket	5	12-380-17	Dowel, locating (4)
3	12-411-01	Rod, push (2)	6	12-755-49	Kit, camshaft (Includes 7,8)
4	12-041-10	Gasket, cylinder head	7	12-089-31	Spring, actuating
5	12-017-01	Valve, intake (Std.)	8	12-422-08	Shim, camshaft (A.R.) blue
	12-017-02	Valve, intake (.25)		12-422-09	Shim, camshaft (A.R.) red
6	12-016-01	Valve, exhaust (Std.)		12-422-10	Shim, camshaft (A.R.) yellow
	12-016-02	Valve, exhaust (.25)		12-422-11	Shim, camshaft (A.R.) green
7	X-75-23	Plug, allen hd. pipe 1/8		12-422-12	Shim, camshaft (A.R.) gray
8	12-318-19	Cylinder Head		12-422-13	Shim, camshaft (A.R.) black
9	25-186-01	Arm, rocker (2)		12-422-07	Shim, camshaft (A.R.) white
10	12-599-03	Pivot, rocker arm (2)	9	12-144-27	Shaft, balance
11	M-0640034	Screw, hex. flange M6x1.0x34 (2)	10	12-874-07	Piston w/Ring Set (Std.)
12	12-089-01	Spring, valve (2)			(Includes 11-12)
13	12-173-01	Cap, valve spring (2)		24-874-11	Piston w/Ring Set (.08)
14	12-755-03	Kit, retainer (2)		12-874-08	Piston w/Ring Set (.25)
15	12-468-05	Washer, plain 13/32		12-874-09	Piston w/Ring Set (.50)
16	12-112-13	Spacer, head bolt exhaust port	11	12-018-02	Retainer, piston pin (2)
17	12-086-15	Screw, hex. flange M10x1.5x81 (5)	12	12-108-07	Ring Set (Std.)
				12-108-08	Ring Set (.25)
18	X-426-9	Clamp, hose (2)		12-108-09	Ring Set (.50)
19	12-326-03	Hose, breather	13	12-067-05	Connecting Rod (Std.)
20	M-0645020	Screw, hex. flange M6x1.0x20 (5)		12-067-06	Connecting Rod (.25)
21	12-096-07	Cover, valve w/nipple	14	12-380-01	Pin, governor regulating
22	M-0545010	Screw, hex. flange M5x0.8x10	15	12-043-05	Gear, governor assembly
23	12-018-01	Retainer, breather reed	16	M-0631005	Washer, plain 6mm
24	12-402-02	Reed, breather	17	12-144-02	Shaft, governor gear
			18	52-139-09	Plug, cup
			19	12-755-64	Kit, gov. cross shaft w/clip
					(Includes 24)
			21	X-25-102	washer, plain 1/4
			22	12-032-01	Seal, governor cross shaft
			23	SM-0631015	Washer, plain 6mm
			24	12-154-05	Clip, hitch pin

**TRACTOR - - MODEL NUMBER 917.271080**  
**KOHLER ENGINE-MODEL NUMBER CV16S, TYPE NUMBER PS-43519**

**IGNITION / ELECTRICAL**

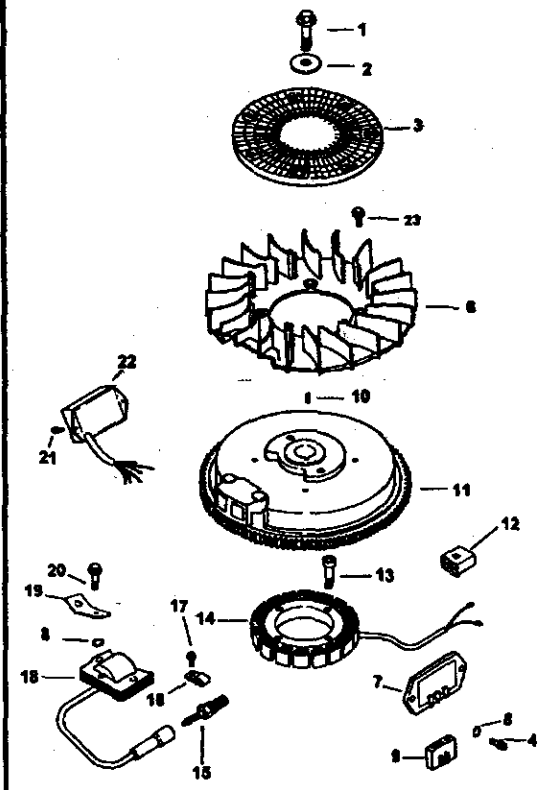

**BLOWER HOUSING AND BAFFLES**

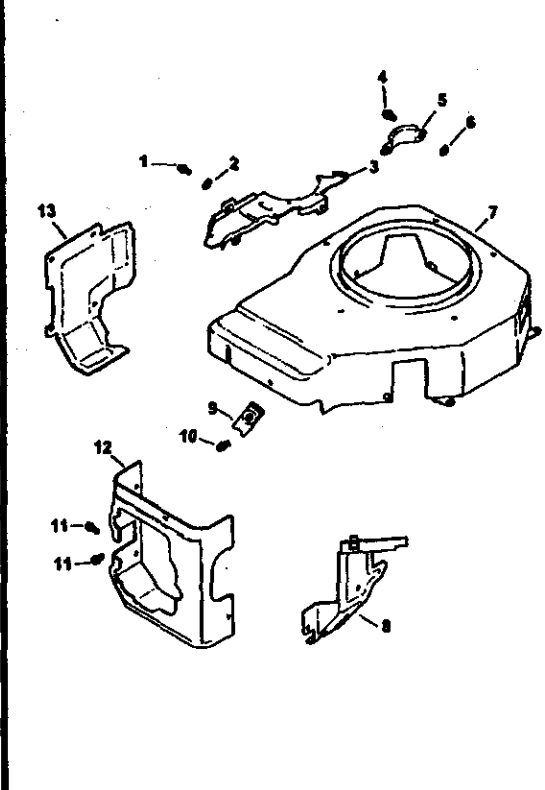

**AIR INTAKE**

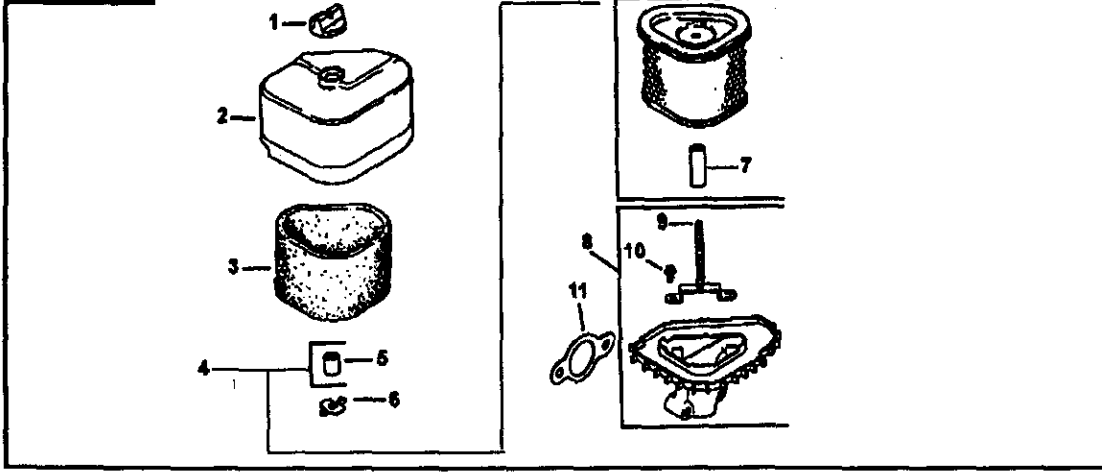

**TRACTOR - - MODEL NUMBER 917.271080**  
**KOHLER ENGINE-MODEL NUMBER CV16S, TYPE NUMBER PS-43519**

**IGNITION/ELECTRICAL**

KEY NO.	PART NO.	DESCRIPTION
1	12-086-14	Screw, hex. flange M10x1.5x46
2	12-468-03	Washer, plain 3/8
3	24-162-03	Screen, grass
4	M-0639016	Screw, hex. flange M6x1.0x16 (6)
6	12-157-03	Fan
7	41-403-09	Regulator, rectifier
8	X-22-11	Washer, lock (2)
9	236602	Connector
10	X-42-15	Key
11	12-025-35	Flywheel
12	41-155-02	Connector (4 contact)
13	M-0548025	Screw, hex. cap M5x0.8x25 (2)
14	12-085-01	Stator assembly - 15 amp
15	12-132-02	Spark Plug
16	X-728-1	Clip, cable
17	M-0545010	Screw, hex. flange M5x0.8x10 (2)
18	12-584-08	Module, ignition
19	12-452-02	Terminal
20	12-086-35	Screw, hex. socket M5x0.8x20 (2)
21	M-0461013	Screw, pan head M4.2x13 (2)
22	12-584-12	Module, speed advance
23	25-086-47	Shoulder M6X1.0X16 (4)

**NOT ILLUSTRATED**

25-518-29	Lead
25-518-05	Lead
12-176-36	Harness
X-25-5	Washer, plain 5/16"
12-155-02	Connector
23-517-03	Clip Cable

**BLOWER HOUSING & BAFFLES**

KEY NO.	PART NO.	DESCRIPTION
1	M-0545010	Screw, hex. flange M5x0.8x10 (8)
2	24-468-10	Washer, plain 1/4
3	12-146-07	Plate, blower housing
4	24-086-18	Screw, phillip hd M4x0.7 X8 (2)
5	24-096-05	Cover, pinion
6	220534	Washer, plain 5/16 (2)
7	12-027-54	Housing, blower
8	12-063-10	Baffle, intake side
9	25-154-02	Clip, mounting (3)
10	12-086-37	Screw,captive washerM5 X0.8 X20 (3)
11	M-0645016	Screw, hex. flange M6x1.0x16 (2)
12	12-063-08	Baffle, cylinder head
13	12-063-09	Baffle, cylinder

**NOT ILLUSTRATED**

X-25-92WASHER, PLAIN 3/16" (2)

**AIR INTAKE/FILTRATION**

KEY NO.	PART NO.	DESCRIPTION
1	25-341-03	Knob, air cleaner cover
2	12-096-24	Cover, air cleaner
3	12-083-12	Pre-cleaner, element
4	12-083-10	Kit air cleaner element (Includes 5,7)
5	1230046	Seal 3/4"
6	12-100-01	Wing Nut
7	12-032-11	Seal 1-7/16"
8	12-094-07	Base, air cleaner(Includes 10,11)
9	12-072-04	Stud, mounting plate M6X1.0X75
10	12-086-01	Screw, #10 Hi-Lo thread forming (2)
11	12-041-02	Gasket, air cleaner

**NOT ILLUSTRATED**

12-113-53 Decal, air cleaner

**TRACTOR -- MODEL NUMBER 917.271080**  
**KOHLER ENGINE-MODEL NUMBER CV16S, TYPE NUMBER PS-43519**

**STARTING SYSTEM**

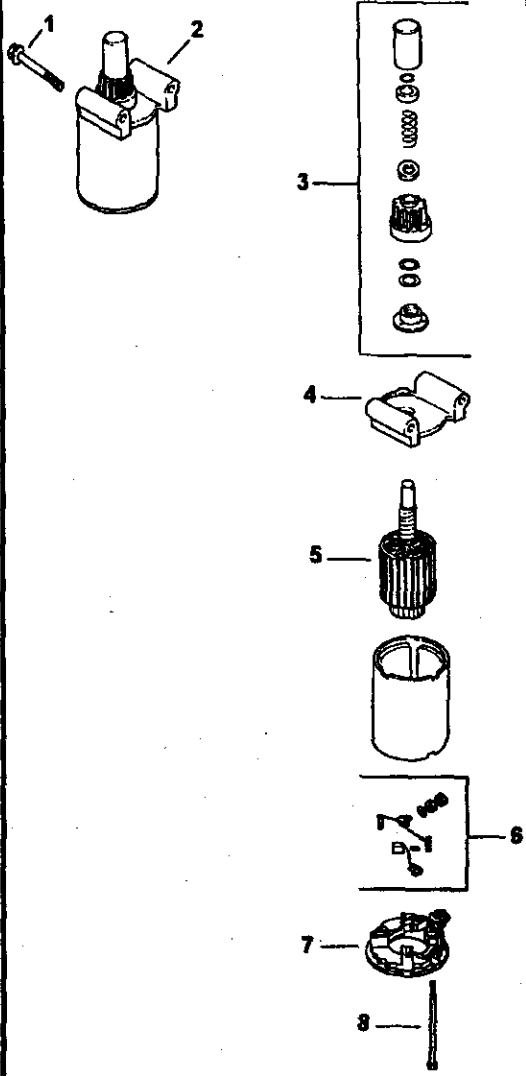

**ENGINE CONTROLS**

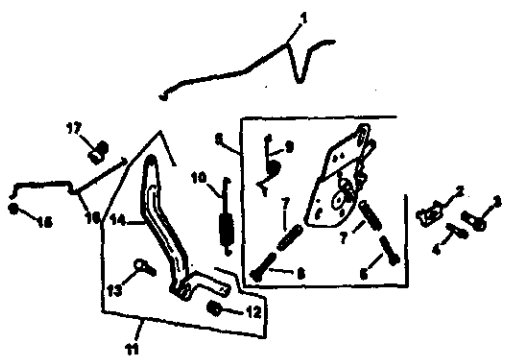

**OIL PAN / LUBRICATION**

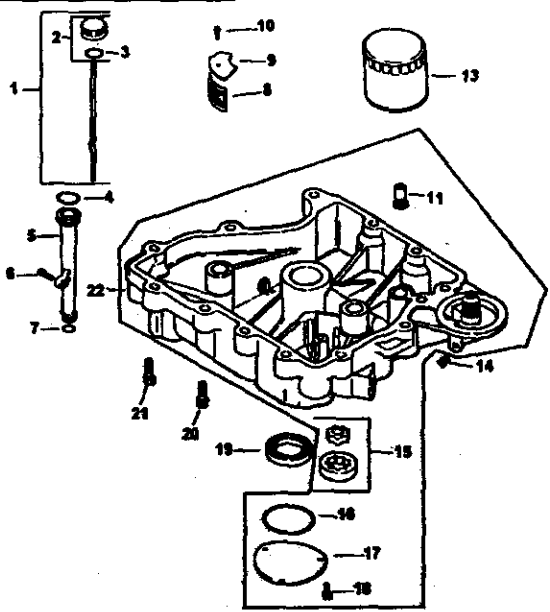



**TRACTOR -- MODEL NUMBER 917.271080**  
**KOHLER ENGINE-MODEL NUMBER CV16S, TYPE NUMBER PS-43519**

**STARTING SYSTEM**

KEY NO.	PART NO.	DESCRIPTION
1	M-0839070	Screw, hex. flange M8x1.25x70 (2)
2	25-098-05	Starter assembly (Includes 3-8)
3	12-755-54	Kit, drive end
4	12-227-06	Cap, drive end
5	12-170-05	Armature
6	12-221-01	Kit, brush & spring
7	12-227-13	Cap, commutator end
8	12-211-01	Bolt, hex. flange 1/4-20x4-5/8 (2)

**ENGINE CONTROLS**

KEY NO.	PART NO.	DESCRIPTION
1	12-079-07	Linkage, choke
2	12-237-01	Clamp, cable
3	M-0664020	Screw, lobed socket M6x1.0x20 (2)
4	24-086-43	Screw, hex. flange
5	12-536-10	Control, speed assembly (Includes 6,8,9)
6	M-0443025	Screw, pan head M4x0.7x25
7	M-0443020	Screw, pan head M4x0.7x20
8	12-089-11	Spring, choke (2)
9	12-089-23	Spring, choke return
10	12-089-24	Spring, governor
11	12-755-83	Kit, governor lever (Includes 12-14)
12	12-100-07	Nut, hex flange 1/4 - 20"
13	52-211-04	Bolt, 1/4 - 20 X 1"
14	12-090-28	Lever, governor
15	25-158-08	Bushing, throttle linkage
16	12-079-01	Linkage, throttle
17	25-158-11	Bushing, throttle linkage

**OIL PAN/LUBRICATION**

KEY NO.	PART NO.	DESCRIPTION
1	12-038-01	Dipstick assembly (Includes 2-3)
2	25-755-13	Kit, oil fill cap (Includes 3)
3	12-153-03	O-Ring, oil fill cap
4	12-153-02	O-Ring, upper oil fill tube
5	12-123-04	Tube, oil fill
6	M-0545020	Screw, hex. flange M5x0.8x20
7	12-153-01	O-Ring, lower oil fill tube
8	25-162-07	Screen, oil pickup
9	12-096-03	Cover, oil pickup screen
10	M-0545016	Screw, hex. flange M5x0.8x16
11	25-462-09	Valve, oil pressure relief
13	52-050-02	Filter, oil
14	X-75-10	Plug, sq. hd. solid 3/8
15	12-393-01	Pump, oil assembly
16	12-153-06	O-Ring, oil pump cover
17	12-096-34	Cover, oil pump
18	M-0545016	Screw, hex. flange M5x0.8x16 (3)
19	12-032-03	Seal, oil (P.T.O. end)
20	24-086-16	Screw, hex. flange M8x1.25x45 (11)
21	24-086-17	Screw, hex. flange M8x1.25x45
22	12-199-53	Assembly, Pan, oil (Incl. 11, 15-18)

**TRACTOR - - MODEL NUMBER 917.271080**  
**KOHLER ENGINE-MODEL NUMBER CV16S, TYPE NUMBER PS-43519**

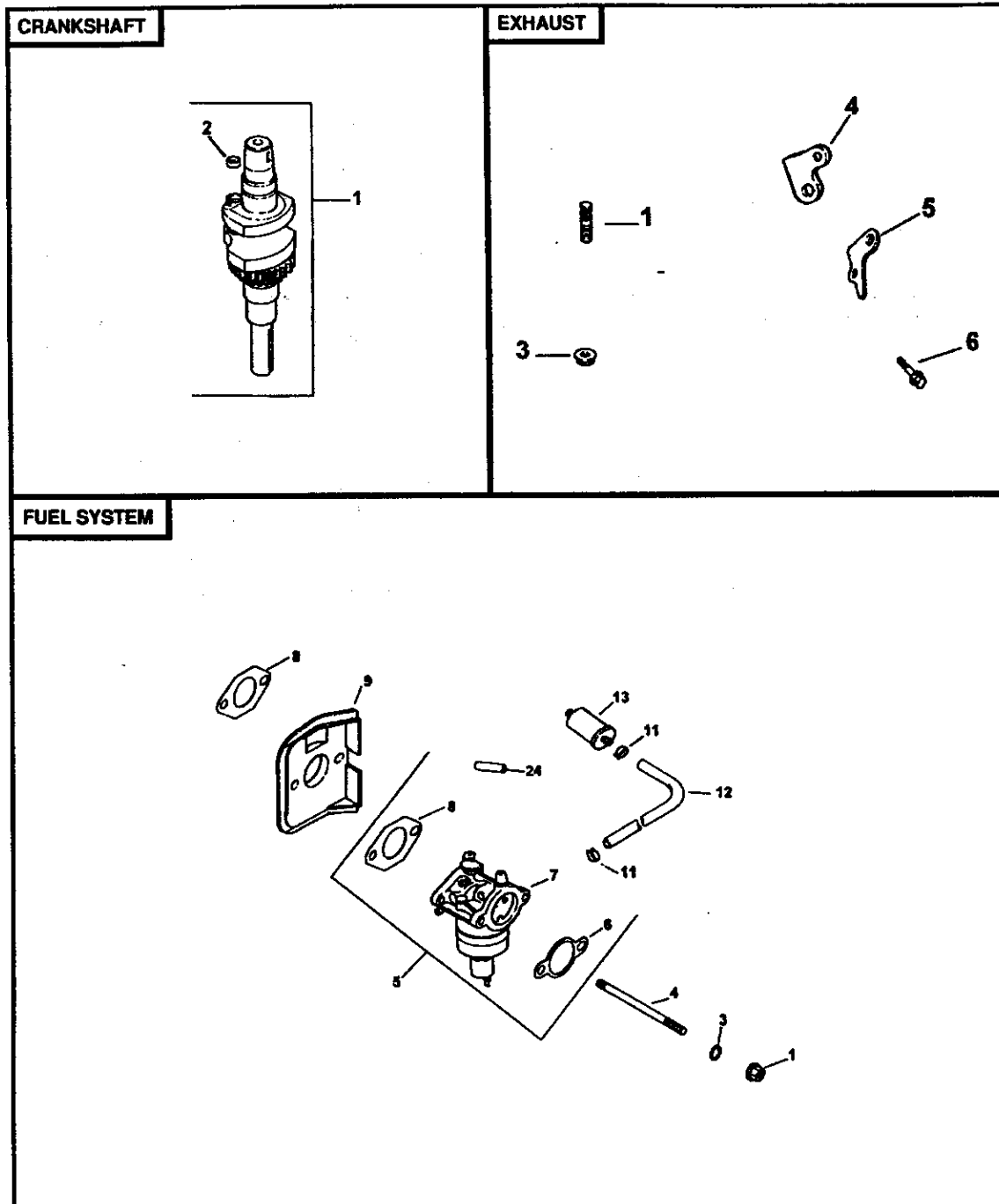

**TRACTOR - - MODEL NUMBER 917.271080**  
**KOHLER ENGINE-MODEL NUMBER CV16S, TYPE NUMBER PS-43519**

**FUEL SYSTEM**

KEY NO.	PART NO.	DESCRIPTION
1	M-0641060	Nut, hex. flange M6x1.0 (2)
3	X-22-11	Washer, star 1/4
4	M-0629116	Stud M6x1.0x116 (2)
5	12-853-95	Kit, carburetor w/gasket (Includes 6,7,8 qty 1 12-454-01, 25452-20)
6	12-041-02	Gasket, air cleaner
7	12-053-95	Carburetor assembly (For information only not available separately)
8	12-041-01	Gasket, carburetor (2)
9	12-265-04	Deflector, heat
10	47-154-01	Clip cable
11	X-426-09	Clamp, hose (2)
12	25-353-10	Line, fuel 9"
13	25-050-02	Filter, fuel

**CRANKSHAFT**

KEY NO.	PART NO.	DESCRIPTION
1	12-014-37	Crankshaft (Includes 2)
2	12-139-01	Plug, cup

**EXHAUST**

KEY NO.	PART NO.	DESCRIPTION
1	25-072-04	Stud (2)
2	12-041-03	Gasket, exhaust manifold
4	12-126-11	Bracket, muffler
5	12-445-06	Strap, lifting
6	M-0645025	Screw, hex. flange M6x1.0x25 (2)
	12-522-18	Short Block
	12-755-82	Gasket Set

**NOT ILLUSTRATED**

12-757-02	Kit, float
12-757-03	Kit, carburetor repair
12-041-01	Gasket, carburetor
12-041-02	Gasket, air cleaner
12-041-05	Gasket, bowl
12-041-06	Gasket, bowl screw
12-032-06	Seal, solenoid
12-757-33	Kit, solenoid repair
12-041-06	Gasket, bowl screw
12-454-01	Tie, wire
25-452-20	Terminal
12-454-03	Tie cable
M-0561010	Screw, thread forming M5X0.8X10
M-0645020	Screw, hex. flange M6X1.0X20 (2)







# SUGGESTED GUIDE FOR SIGHTING SLOPES FOR SAFE OPERATION

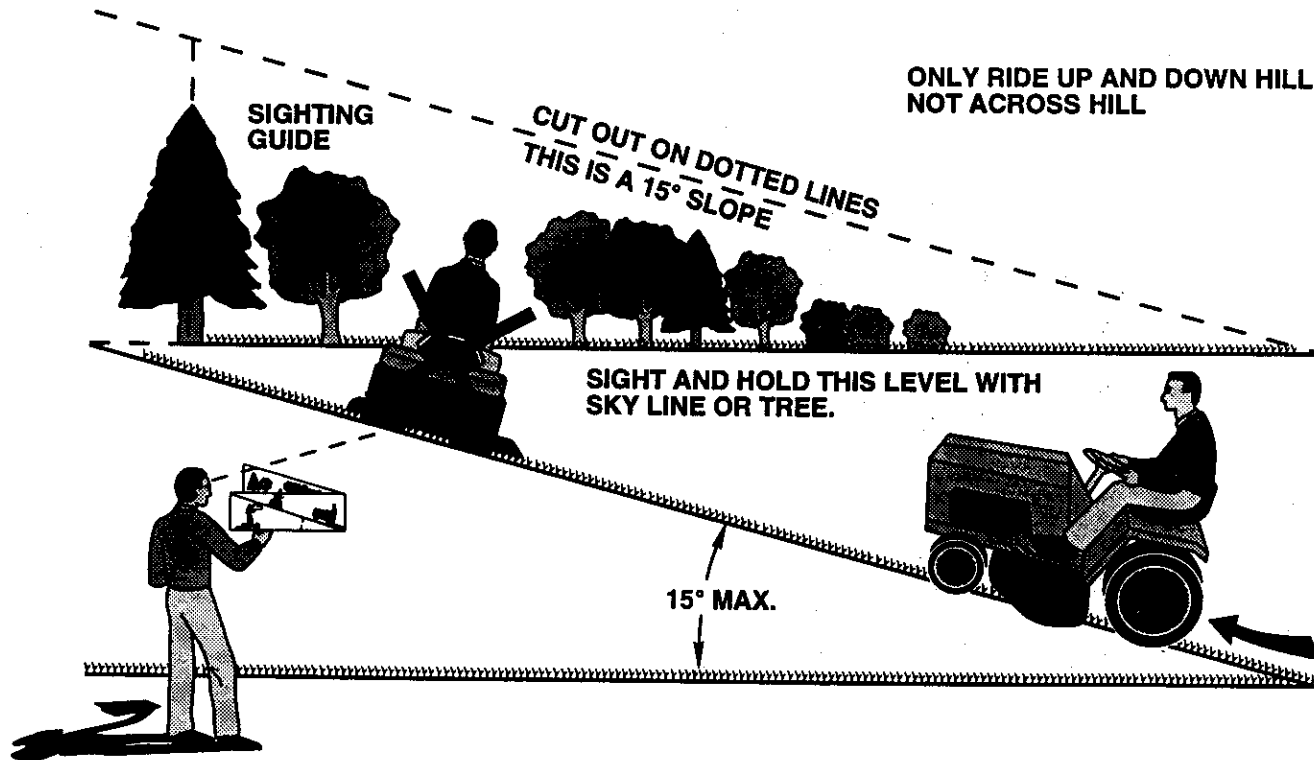

Operate your Tractor up and down the face of slopes (not greater than 15°), never across the face. Make turns gradually to prevent tipping or loss of control. Exercise extreme caution when changing direction on slopes.

**For in-home major brand repair service:**  
Call 24 hours a day, 7 days a week

**1-800-4-MY-HOME<sup>SM</sup>** (1-800-469-4663)  
**Para pedir servicio de reparación a domicilio**  
**1-800-676-5811**

In Canada for all your service and parts needs call  
Au Canada pour tout le service ou les pièces  
**1-800-665-4455**

**For the repair or replacement parts you need:**  
Call 6 am-11pm CST, 7 days a week  
**PartsDirect<sup>SM</sup>**  
**1-800-366-PART** (1-800-366-7278)

**Para ordenar piezas con entrega a domicilio**  
**1-800-659-7084**

**For the location of a Sears Parts and Repair Center**  
**in your area:**  
Call 24 Hours a day, 7 days a week  
**1-800-488-1222**

**For information on purchasing a Sears Maintenance**  
**Agreement or to inquire about an existing Agreement:**  
Call 9 am-5 pm, Monday - Saturday  
**1-800-827-6655**





## Free Manuals Download Website

<http://myh66.com>

<http://usermanuals.us>

<http://www.somanuals.com>

<http://www.4manuals.cc>

<http://www.manual-lib.com>

<http://www.404manual.com>

<http://www.luxmanual.com>

<http://aubethermostatmanual.com>

Golf course search by state

<http://golfingnear.com>

Email search by domain

<http://emailbydomain.com>

Auto manuals search

<http://auto.somanuals.com>

TV manuals search

<http://tv.somanuals.com>