

Owner's Manual



**5.5 HP
14 INCH TINE WIDTH
REAR TINE WITH
COUNTER ROTATING TINES
TILLER**

Model No.
917.293470

- Safety
- Assembly
- Operation
- Maintenance
- Español
- Repair Parts

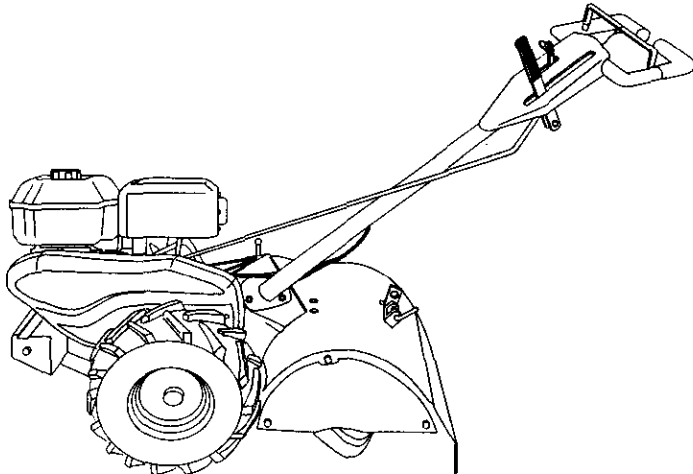

This product has a low emission engine which operates differently from previously built engines. Before you start the engine, read and understand this Owner's Manual.

CAUTION:

Read and follow all Safety Rules and Instructions before operating this equipment.

Sears, Roebuck and Co., Hoffman Estates, IL 60179
Visit our Craftsman website: www.sears.com/craftsman

TABLE OF CONTENTS

Safety Rules	2	Maintenance	13
Warranty	2	Service and Adjustments	15
Product Specifications	4	Storage	19
Assembly	5	Troubleshooting	20
Operation	8	Illustrated Parts List	42
Maintenance Schedule	13	Parts Ordering	Back Cover

WARRANTY

LIMITED ONE YEAR WARRANTY ON CRAFTSMAN TILLER

For one (1) year from date of purchase, when this Craftsman Tiller is maintained, lubricated, and tuned up according to the operating and maintenance instructions in the owner's manual, Sears will repair free of charge any defect in material or workmanship.

This Warranty does not cover:

- Expendable items which become worn during normal use, such as tines, spark plugs, air cleaners and belts.
- Repairs necessary because of operator abuse or negligence, including bent crankshafts and the failure to maintain the equipment according to the instructions contained in the owner's manual.
- If this Craftsman Tiller is used for commercial or rental purposes, this Warranty applies for only thirty (30) days from the date of purchase.

Warranty service is available by returning the craftsman power mower to the nearest sears service center/department in the united states. This warranty applies only while this product is in use in the united states.

This Warranty gives you specific legal rights, and you may also have other rights which vary from state to state.

SEARS, ROEBUCK AND CO., D/817WA, HOFFMAN ESTATES, IL 60179

SAFETY RULES

IMPORTANT: This cutting machine is capable of amputating hands and feet and throwing objects. Failure to observe the following safety instructions could result in serious injury or death.

TRAINING

- Read the Owner's Manual carefully. Be thoroughly familiar with the controls and the proper use of the equipment. Know how to stop the unit and disengage the controls quickly.
- Never allow children to operate the equipment. Never allow adults to operate the equipment without proper instruction.
- Keep the area of operation clear of all persons, particularly small children, and pets.

PREPARATION

- Thoroughly inspect the area where the equipment is to be used and remove all foreign objects.

- Disengage all clutches and shift into neutral before starting the engine (motor).
- Do not operate the equipment without wearing adequate outer garments. Wear footwear that will improve footing on slippery surfaces.
- Handle fuel with care; it is highly flammable.
- Use an approved fuel container.
- Never add fuel to a running engine or hot engine.
- Fill fuel tank outdoors with extreme care. Never fill fuel tank indoors.
- Replace gasoline cap securely and clean up spilled fuel before restarting.
- Use extension cords and receptacles as specified by the manufacturer for all units with electric drive motors or electric starting motors.

SAFETY RULES

- Never attempt to make any adjustments while the engine (motor) is running (except where specifically recommended by manufacturer).

OPERATION

- Do not put hands or feet near or under rotating parts.
- Exercise extreme caution when operating on or crossing gravel drives, walks, or roads. Stay alert for hidden hazards or traffic. Do not carry passengers.
- After striking a foreign object, stop the engine (motor), remove the wire from the spark plug, thoroughly inspect the tiller for any damage, and repair the damage before restarting and operating the tiller.
- Exercise caution to avoid slipping or falling.
- If the unit should start to vibrate abnormally, stop the engine (motor) and check immediately for the cause. Vibration is generally a warning of trouble.
- Stop the engine (motor) when leaving the operating position.
- Take all possible precautions when leaving the machine unattended. Disengage the tines, shift into neutral, and stop the engine.
- Before cleaning, repairing, or inspecting, shut off the engine and make certain all moving parts have stopped. Disconnect the spark plug wire, and keep the wire away from the plug to prevent accidental starting. Disconnect the cord on electric motors.
- Do not run the engine indoors; exhaust fumes are dangerous.
- Never operate the tiller without proper guards, plates, or other safety protective devices in place.
- Keep children and pets away.
- Do not overload the machine capacity by attempting to till too deep at too fast a rate.
- Never operate the machine at high speeds on slippery surfaces. Look behind and use care when backing.
- Never allow bystanders near the unit.
- Use only attachments and accessories approved by the manufacturer of the tiller.

- Never operate the tiller without good visibility or light.
- Be careful when tilling in hard ground. The tines may catch in the ground and propel the tiller forward. If this occurs, let go of the handlebars and do not restrain the machine.

MAINTENANCE AND STORAGE

- Keep machine, attachments, and accessories in safe working condition.
- Check shear pins, engine mounting bolts, and other bolts at frequent intervals for proper tightness to be sure the equipment is in safe working condition.
- Never store the machine with fuel in the fuel tank inside a building where ignition sources are present, such as hot water and space heaters, clothes dryers, and the like. Allow the engine to cool before storing in any enclosure.
- Always refer to the operator's guide instructions for important details if the tiller is to be stored for an extended period.

▲ Look for this symbol to point out important safety precautions. It means **CAUTION!!! BECOME ALERT!!! YOUR SAFETY IS INVOLVED.**

▲ **CAUTION:** Always disconnect spark plug wire and place wire where it cannot contact spark plug in order to prevent accidental starting when setting up, transporting, adjusting or making repairs.

▲ **WARNING:** Engine exhaust, some of its constituents, and certain vehicle components contain or emit chemicals known to the State of California to cause cancer and birth defects or other reproductive harm.

PRODUCT SPECIFICATIONS

GASOLINE CAPACITY:	3 QUARTS UNLEADED REGULAR
OIL (API-SF-SJ): (CAPACITY: 20 OZ.)	SAE 30 (ABOVE 32°F) SAE 5W-30 (BELOW 32°F)
SPARK PLUG : (GAP: .030")	CHAMPION RJ19LM OR J19LM

CONGRATULATIONS on your purchase of a Sears Tiller. It has been designed, engineered and manufactured to give you the best possible dependability and performance.

Should you experience any problems you cannot easily remedy, please contact a Sears or other qualified Service Center. We have competent, well-trained technicians and the proper tools to service or repair this unit.

Please read and retain this manual. The instructions will enable you to assemble and maintain your tiller properly. Always observe the "SAFETY RULES".

Your new tiller has been assembled at the factory with exception of those parts left unassembled for shipping purposes. To ensure safe and proper operation of your tiller all parts and hardware you assemble must be tightened securely. Use the correct tools as necessary to insure proper tightness.

CUSTOMER RESPONSIBILITIES

- Read and observe the safety rules.
- Follow a regular schedule in maintaining, caring for and using your tiller.
- Follow the instructions under the "Customer Responsibilities" and "Storage" sections of this Owner's Manual.







WARNING: This unit is equipped with an internal combustion engine and should not be used on or near any unimproved forest-covered, brush-covered or grass covered land unless the engine's exhaust system is equipped with a spark arrester meeting applicable local or state laws (if any). If a spark arrester is used, it should be maintained in effective working order by the operator.

In the state of California the above is required by law (Section 4442 of the California Public Resources Code). Other states may have similar laws. Federal laws apply on federal lands. A spark arrester for the muffler is available through your nearest Sears service center (See REPAIR PARTS section of this manual).

ACCESSORIES

These accessories were available when the tiller was purchased. They are also available at most Sears Retail outlets and Service Centers. Most Sears Stores can order repair parts for you when you provide the model number of your tiller.





ENGINE

SPARK PLUG	MUFFLER	AIR FILTER	GAS CAN	ENGINE OIL	STABILIZER
					

TILLER PERFORMANCE

FURROW OPENER

TILLER MAINTENANCE

BELT	TINES	SHEAR PIN	HARPIN CLIP
			

ASSEMBLY

Your new tiller has been assembled at the factory with exception of those parts left unassembled for shipping purposes. To ensure safe and proper operation of your tiller all parts and hardware you assemble must be tightened securely. Use the correct tools as necessary to insure proper tightness.

TOOLS REQUIRED FOR ASSEMBLY

A socket wrench set will make assembly easier. Standard wrench sizes are listed.

- (1) Utility knife
- (1) Wire cutter
- (1) Tire pressure gauge
- (1) Screwdriver
- (1) Pair of pliers
- (1) 9/16" wrench

OPERATOR'S POSITION

When right or left hand is mentioned in this manual, it means when you are in the operating position (standing behind tiller handles).

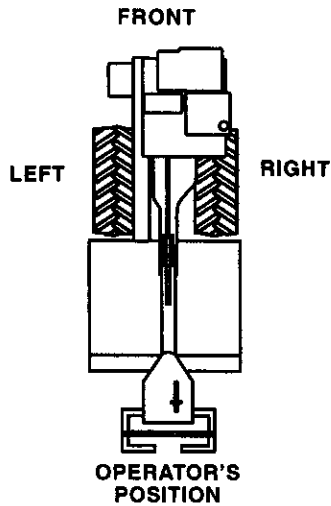

CONTENTS OF HARDWARE PACK



(2) Handle Locks

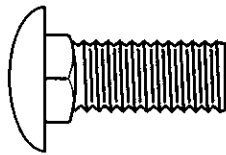

(1) Carriage Bolt
3/8-16 UNC x 1 Gr. 5



(1) Center Locknut
3/8-16 UNC

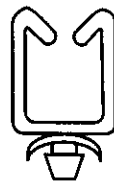

(1) Cable Clip



(1) Hairpin Clips

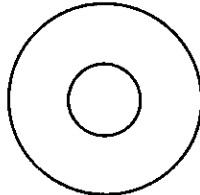

(1) Flat Washer
13/32 x 1 x 11 Ga.

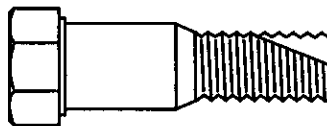

(1) Pivot Bolt
3/8-16 UNC Grade 5

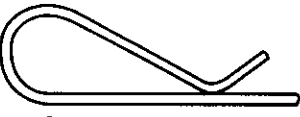

(2) Shear Pins & Clips

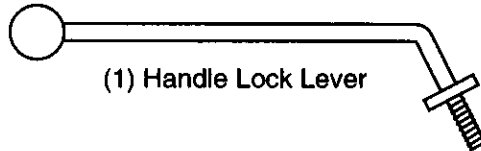

(1) Handle Lock Lever

UNPACKING CARTON

CAUTION: Be careful of exposed staples when handling or disposing of cartoning material.

IMPORTANT: When unpacking and assembling tiller, be careful of exposed staples when handling or disposing of cartoning material.

1. While holding handle assembly, cut cable ties securing handle assembly to top frame. Let handle assembly rest on tiller.
2. Remove top frame of carton.
3. Slowly ease handle assembly up and place on top of carton.
4. Cut down right hand front and right hand rear corners of carton, lay side carton wall down.
5. Remove packing material from handle assembly.
6. Separate shift rod from handle assembly.

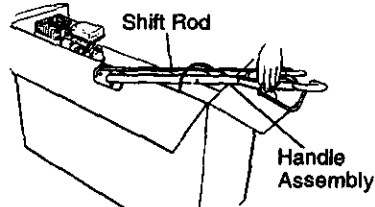

INSTALL HANDLE

1. Insert one handle lock (with teeth facing outward) in gearcase notch. (Apply grease on smooth side of handle lock to aid in keeping lock in place until handle assembly is lowered into position.)

VIEWED FROM R.H. SIDE OF TILLER

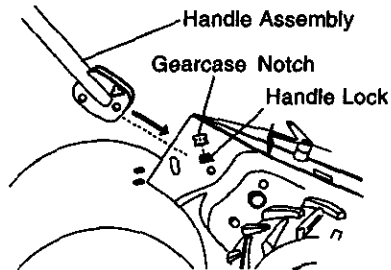

2. Grasp handle assembly. Hold in "up" position. Be sure handle lock remains in gearcase notch. Slide handle assembly into position.
3. Rotate handle assembly down. Insert rear carriage bolt first, with head of bolt on L.H. side of tiller and loosely assemble locknut.

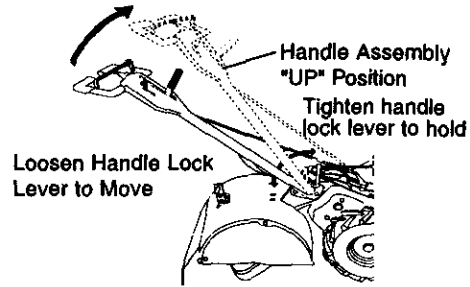

4. Insert pivot bolt in front part of plate and tighten.
5. Cut down remaining corners of carton and lay panels flat.
6. Lower the handle assembly. Tighten nut on carriage bolt so handle moves with some resistance. This will allow for easier adjustment.
7. Place flat washer on threaded end of handle lock lever.
8. Insert handle lock lever through handle base and gearcase. Screw in handle lock lever just enough to hold lever in place.
9. Insert second handle lock (with teeth inward) in the slot of the handle base (just inside of washer).
10. Raise handle assembly to highest position and securely tighten handle lock lever by rotating clockwise. Leaving handle assembly in highest position will make it easier to connect shift rod.

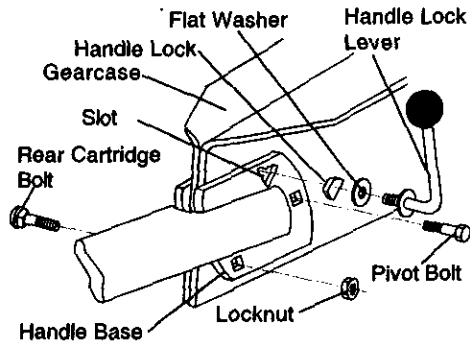

INSERT CABLE CLIP

- Insert plastic cable clip into hole on the back of handle column. Push cables into clip.

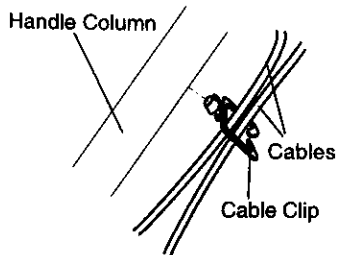

CONNECT SHIFT ROD

1. Insert end of shift rod farthest from bend into hole of shift lever indicator.
2. Insert hairpin clip through hole of shift rod to secure with bend of clip on right side.

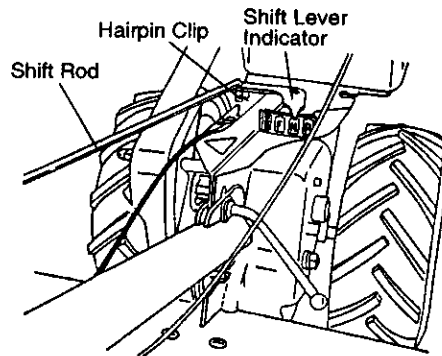
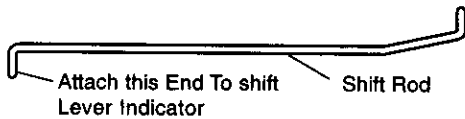

REMOVE TILLER FROM CRATE

1. Adjust handle assembly to lowest position. Be sure lock lever is tightened securely.
2. Make sure shift lever indicator is in "N" (neutral) position.
3. Tilt tiller forward by lifting handle. Separate cardboard cover from leveling shield.
4. Rotate tiller handle to the right and pull tiller out of carton.

CHECK TIRE PRESSURE

The tires on your unit were overinflated at the factory for shipping purposes. Correct and equal tire pressure is important for best tilling performance.

- Reduce tire pressure to 20 PSI.

HANDLE HEIGHT

- Handle height may be adjusted to better suit operator. (See "TO ADJUST HANDLE HEIGHT" in the Service and Adjustments section of this manual).

OPERATION

These symbols may appear on your Tiller or in literature supplied with the product. Learn and understand their meaning.

KNOW YOUR TILLER

READ THIS OWNER'S MANUAL AND SAFETY RULES BEFORE OPERATING YOUR TILLER.

Compare the illustrations with your tiller to familiarize yourself with the location of various controls and adjustments. Save this manual for future reference.

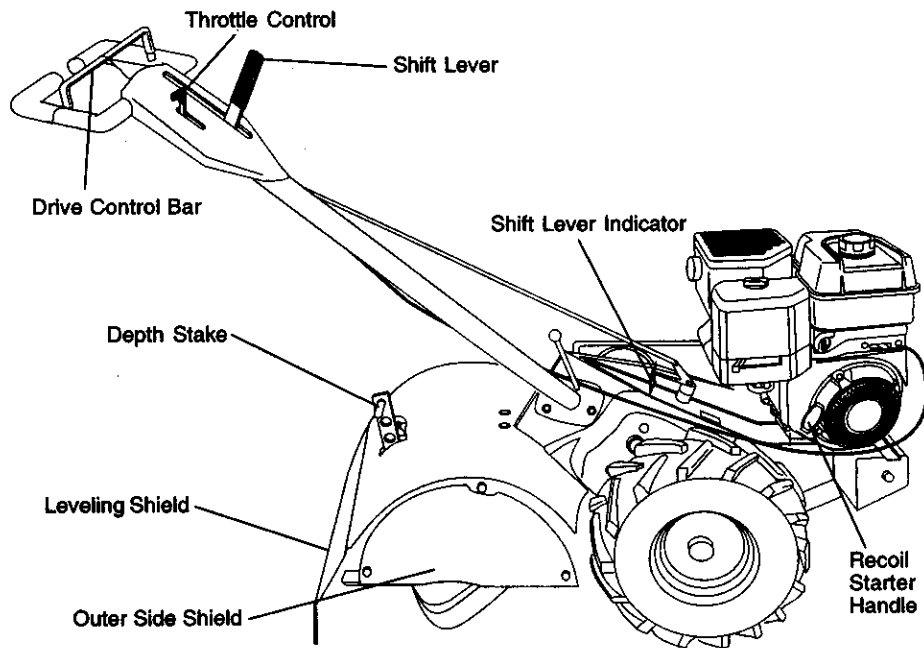
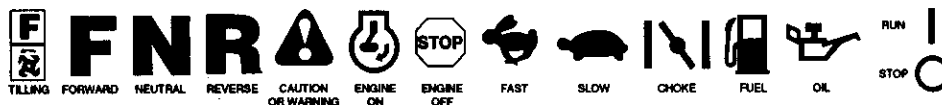

MEETS ANSI SAFETY REQUIREMENTS

Our tillers conform to the safety standards of the American National Standards Institute.

DRIVE CONTROL BAR - Used to engage tines.

DEPTH STAKE - Controls depth at which tiller will dig.

OUTER SIDE SHIELD - Adjustable to protect small plants from being buried.

THROTTLE CONTROL - Used to control engine speed.

LEVELING SHIELD - Levels tilled soil.

SHIFT LEVER - Used to shift transmission gears.

SHIFT LEVER INDICATOR - Shows which gear the transmission is in.

RECOIL STARTER HANDLE - Used to start the engine.



The operation of any tiller can result in foreign objects thrown into the eyes, which can result in severe eye damage. Always wear safety glasses or eye shields before starting your tiller and while tilling. We recommend a wide vision safety mask over spectacles or standard safety glasses.

HOW TO USE YOUR TILLER

Know how to operate all controls before adding fuel and oil or attempting to start engine.

STOPPING

TINES AND DRIVE

1. Release drive control bar to stop movement.
2. Move shift lever to "N" (neutral) position.

ENGINE

- Move throttle control to "STOP" position. If equipped with stop switch, move switch to "STOP" position.

NOTE: Never use choke to stop engine.

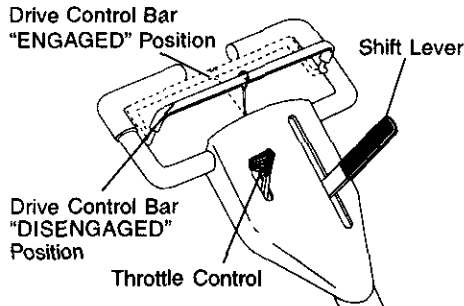

TINE OPERATION - WITH WHEEL DRIVE

- Always release drive control bar before moving shift lever into another position.
- Tine movement is achieved by moving shift lever to (F) till position and engaging drive control bar.

FORWARD - WHEELS ONLY/TINES STOPPED

- Release drive control bar and move shift lever indicator to "F" (forward) position. Engage drive control bar and tiller will move forward.

REVERSE - WHEELS ONLY/TINES STOPPED

1. DO NOT STAND DIRECTLY BEHIND TILLER.
2. Release the drive control bar.
3. Move throttle control to "SLOW" position.
4. Move shift lever indicator to "R" (reverse) position.
5. Hold drive control bar against the handle to start tiller movement.

HARD TO SHIFT GEARS

- Briefly engage drive control bar and release or rock tiller forward and backward until are able to shift gears.

DEPTH STAKE

The depth stake can be raised or lowered to allow you more versatile tilling and cultivating, or to more easily transport your tiller.

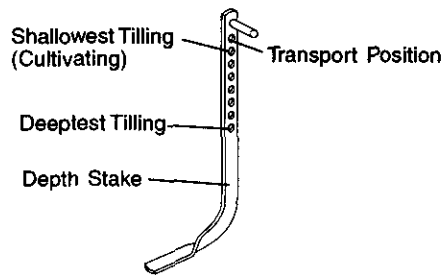

TILLING

1. Release depth stake pin. Pull the depth stake up for increased tilling depth. Place depth stake pin in hole of depth stake to lock in position.
2. Place shift lever indicator in till position.
3. Hold the drive control bar against the handle to start tilling movement. Tines and wheels will both turn.
4. Move throttle control to "FAST" position for deep tilling. To cultivate, throttle control can be set at any desired speed, depending on how fast or slow you wish to cultivate.

IMPORTANT: Always release drive control bar before moving shift lever into another position.

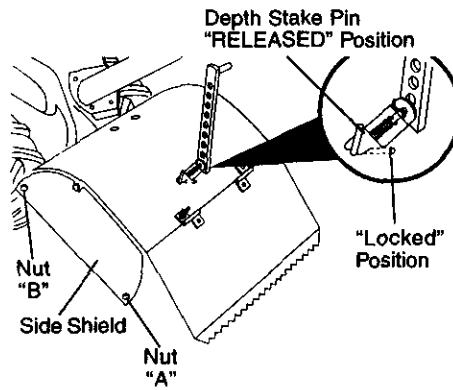

TURNING

1. Release the drive control bar.
2. Move throttle control to "SLOW" position.
3. Place shift lever indicator in "F" (forward) position. Tines will not turn.
4. Lift handle to raise tines out of ground.
5. Swing the handle in the opposite direction you wish to turn, being careful to keep feet and legs away from tines.
6. When you have completed your turn-around, release the drive control bar and lower handle. Place shift lever in (till) position and move throttle control to desired speed. To begin tilling, hold drive control bar against the handle.

OUTER SIDE SHIELDS

The back edges of the outer side shields are slotted so that the shields can be raised for deep tilling and lowered for shallow tilling to protect small plants from being buried.

1. Loosen nut "A" in slot and nut "B".
2. Move shield to desired position (both sides).
3. Retighten nuts.

TOTRANSPORT

CAUTION: Before lifting or transporting, allow tiller engine and muffler to cool. Disconnect spark plug wire. Drain gasoline from fuel tank.

AROUND THE YARD

1. Release the depth stake pin. Move the depth stake down to the top hole for transporting the tiller. Place depth stake pin in hole of depth stake to lock in position. This prevents tines from scuffing the ground.
2. Place shift lever indicator in "F" (forward) position for transporting.
3. Hold the drive control bar against the handle to start tiller movement. Tines will not turn.
4. Move throttle control to desired speed.

AROUND TOWN

1. Disconnect spark plug wire.
2. Drain fuel tank.
3. Transport in upright position to prevent oil leakage.

BEFORE STARTING ENGINE

IMPORTANT: Be very careful not to allow dirt to enter the engine when checking or adding oil or fuel. Use clean oil and fuel and store in approved, clean, covered containers. use clean fill funnels.

CHECK ENGINE OIL LEVEL

The engine in your unit has been shipped, from the factory, already filled with SAE 30 summer weight oil.

1. With engine level, clean area around oil filler plug and remove plug.
 2. Engine oil should be to point of overflowing when engine is level.
- For approximate capacity see "PRODUCT SPECIFICATIONS" on page 4 of this manual. All oil must meet A.P.I. Service Classification SF-SJ.
 - For cold weather operation you should change oil for easier starting (See oil viscosity chart in the Maintenance section of this manual).
 - To change engine oil, see the Maintenance section in this manual.

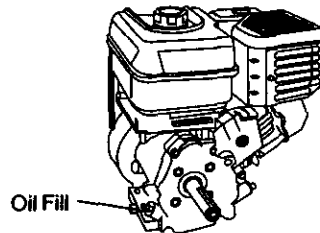

ADD GASOLINE

- Fill fuel tank. Use fresh, clean, regular unleaded gasoline. (Use of leaded gasoline will increase carbon and lead oxide deposits and reduce valve life.)

IMPORTANT: When operating in temperatures below 32°F(0°C), use fresh, clean, winter grade gasoline to help insure good cold weather starting.

WARNING: Experience indicates that alcohol blended fuels (called gasohol or using ethanol or methanol) can attract moisture which leads to separation and formation of acids during storage. Acidic gas can damage the fuel system of an engine while in storage. **To avoid engine problems, the fuel system should be emptied before storage of 30 days or longer.** Drain the gas tank, start the engine and let it run until the fuel lines and carburetor are empty. **Use fresh fuel next season.** See Storage section of this manual for additional information. Never use engine or carburetor cleaner products in the fuel tank or permanent damage may occur.

CAUTION: Fill to within 1/2 inch of top of fuel tank to prevent spills and to allow for fuel expansion. If gasoline is accidentally spilled, move machine away from area of spill. Avoid creating any source of ignition until gasoline vapors have disappeared.

Do not overfill. Wipe off any spilled oil or fuel. Do not store, spill or use gasoline near an open flame.

TO START ENGINE

CAUTION: Keep drive control bar in "DISENGAGED" position when starting engine.

When starting engine for the first time or if engine has run out of fuel, it will take extra pulls of the recoil starter to move fuel from the tank to the engine.

1. Make sure spark plug wire is properly connected.
2. Move shift lever indicator to "N" (neutral) position.
3. Place throttle control in "FAST" position.
4. Turn fuel shut-off valve 1/4 turn to open position.
5. Move choke control to choke position.
6. Grasp recoil starter handle with one hand and grasp tiller handle with other hand. Pull rope out slowly until engine reaches start of compression cycle (rope will pull slightly harder at this point).
7. Pull recoil starter handle quickly. Do not let starter handle snap back against starter.

NOTE: If engine fires but does not start, move choke control to half choke position. Pull recoil starter handle until engine starts.

8. When engine starts, slowly move choke control to "RUN" position as engine warms up.

NOTE: A warm engine requires less choking to start.

9. Move throttle control to desired running position.
10. Allow engine to warm up for a few minutes before engaging tines.

NOTE: If at a high altitude (3000 feet) or in cold temperatures (below 32°F), the carburetor fuel mixture may need to be adjusted for best engine performance. See "TO ADJUST CARBURETOR" in the Service and Adjustments section of this manual.

NOTE: If engine does not start, see troubleshooting points.

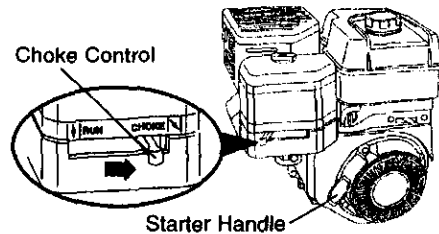

TILLING HINTS

CAUTION: Until you are accustomed to handling your tiller, start actual field use with throttle in slow position (mid-way between "FAST" and "IDLE").

- Tilling is digging into, turning over, and breaking up packed soil before planting. Loose, unpacked soil helps root growth. Best tilling depth is 4" to 6". A tiller will also clear the soil of unwanted vegetation. The decomposition of this vegetable matter enriches the soil. Depending on the climate (rainfall and wind), it may be advisable to till the soil at the end of the growing season to further condition the soil.
- Soil conditions are important for proper tilling. Tines will not readily penetrate dry, hard soil which may contribute to excessive bounce and difficult handling of your tiller. Hard soil should be moistened before tilling; however, extremely wet soil will "ball-up" or clump during tilling. Wait until the soil is less wet in order to achieve the best results. When tilling in the fall, remove vines and long grass to prevent them from wrapping around the tine shaft and slowing your tilling operation.
- You will find tilling much easier if you leave a row untilled between passes. Then go back between tilled rows. There are two reasons for doing this. First, wide turns are much easier to negotiate than about-faces. Second, the tiller won't be pulling itself, and you, toward the row next to it.
- Do not lean on handle. This takes weight off the wheels and reduces traction. To get through a really tough section of sod or hard ground, apply upward pressure on handle or lower the depth stake.

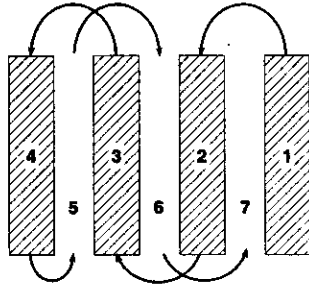

CULTIVATING

Cultivating is destroying the weeds between rows to prevent them from robbing nourishment and moisture from the plants. At the same time, breaking up the upper layer of soil crust will help retain moisture in the soil. Best digging depth is 1" to 3" (2.5-7.5 cm). Lower the outer side shields to protect small plants from being buried.

- Cultivate up and down the rows at a speed which will allow tines to uproot weeds and leave the ground in rough condition, promoting no further growth of weeds and grass.

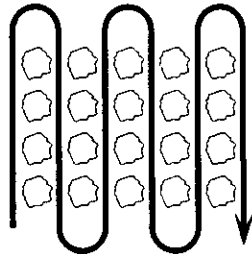

TINE SHEAR PINS

The tine assemblies on your tiller are secured to the tine shaft with shear pins (See "TINE REPLACEMENT" in the Service and Adjustments section of this manual).

If the tiller is unusually overloaded or jammed, the shear pins are designed to break before internal damage occurs to the transmission.

- If shear pin(s) break, replace only with those shown in the Repair Parts section of this manual.

ADJUST WHEELS FOR CULTIVATING

1. Place blocks under right hand side of tiller and remove hairpin clip and clevis pin from right hand wheel.
2. Move wheel outward approximately 1 inch until hole in inner wheel hub lines up with inner hole in axle.
3. Replace clevis pin and hairpin clip on inside of wheel and remove blocks.
4. Repeat preceding steps on left hand side.

NOTE: In extremely rough conditions and while cultivating, the wheels should be moved outward on the axle for increased stability.

OUTER VIEW OF TIRE

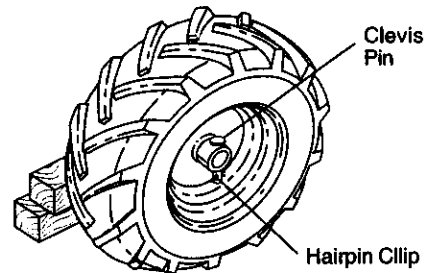

INNER VIEW OF TIRE

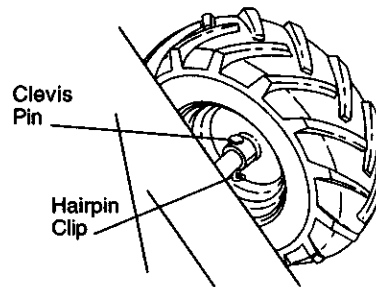

MAINTENANCE

MAINTENANCE SCHEDULE	SERVICE DATES				
FILL IN DATES AS YOU COMPLETE REGULAR SERVICE	BEFORE EACH USE	EVERY 5 HOURS	EVERY 25 HOURS	EVERY 50 HOURS	EVERY SEASON
Check Engine Oil Level	✓	✓			
Change Engine Oil			✓ _{1,2}		
Oil Pivot Points		✓			
Inspect Spark Arrestor / Muffler			✓		
Inspect Air Screen	✓				
Clean or Replace Air Cleaner Cartridge			✓ ₂		
Clean Engine Cylinder Fins			✓		
Replace Spark Plug			✓		
RH Gear Case Grease Fitting (1oz.)				✓	

1 - Change more often when operating under a heavy load or in high ambient temperatures.
 2 - Service more often when operating in dirty or dusty conditions.

GENERAL RECOMMENDATIONS

The warranty on this tiller does not cover items that have been subjected to operator abuse or negligence. To receive full value from the warranty, the operator must maintain tiller as instructed in this manual.

Some adjustments will need to be made periodically to properly maintain your tiller.

All adjustments in the Service and Adjustments section of this manual should be checked at least once each season.

- Once a year you should replace the spark plug, clean or replace air filter, and check tines and belts for wear. A new spark plug and clean air filter assure proper air-fuel mixture and help your engine run better and last longer.

BEFORE EACH USE

1. Check engine oil level.
2. Check tine operation.
3. Check for loose fasteners.

LUBRICATION

Keep unit well lubricated (See "LUBRICATION CHART").

LUBRICATION CHART

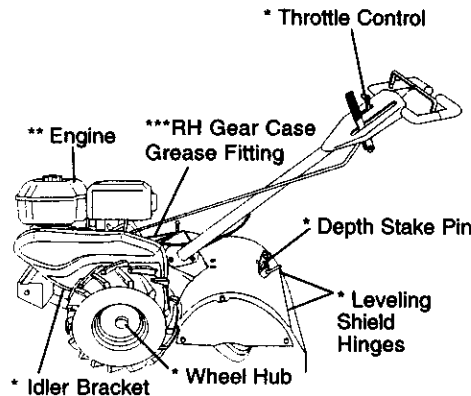

- * SAE 30 OR 5W-30 Motor Oil
- ** Refer to Maintenance "ENGINE" Section
- *** EP #1 Grease

CAUTION: Disconnect spark plug wire before performing any maintenance (except carburetor adjustment) to prevent accidental starting of engine. Prevent fires! Keep the engine free of grass, leaves, spilled oil, or fuel. Remove fuel from tank before tipping unit for maintenance. Clean muffler area of all grass, dirt, and debris. Do not touch hot muffler or cylinder fins as contact may cause burns.

ENGINE LUBRICATION

Use only high quality detergent oil rated with API service classification SF-SJ. Select the oil's SAE viscosity grade according to your expected temperature.

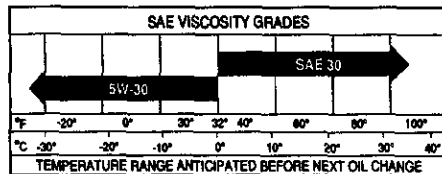

NOTE: Although multi-viscosity oils (5W-30, 10W-30, etc.) improve starting in cold weather, these multi-viscosity oils will result in increased oil consumption when used above 32°F (0°C). Check your engine oil level more frequently to avoid possible engine damage from running low on oil.

Change the oil after every 50 hours of operation or at least once a year if the tiller is not used for 50 hours in one year. Check the crankcase oil level before starting the engine and after each five (5) hours of continuous use. Add SAE 30 motor oil or equivalent. Tighten oil filler plug securely each time you check the oil level.

TO CHANGE ENGINE OIL

Determine temperature range expected before oil change. All oil must meet API service classification SF-SJ.

- Be sure tiller is on level surface.
 - Oil will drain more freely when warm.
 - Use a funnel to prevent oil spill on tiller, and catch oil in a suitable container.
1. Remove drain plug.
 2. Tip tiller forward to drain oil.
 3. After oil has drained completely, replace oil drain plug and tighten securely.
 4. Remove oil filler plug. Be careful not to allow dirt to enter the engine.

5. Refill engine with oil. See "CHECK ENGINE OIL LEVEL" in the Operation section of this manual.

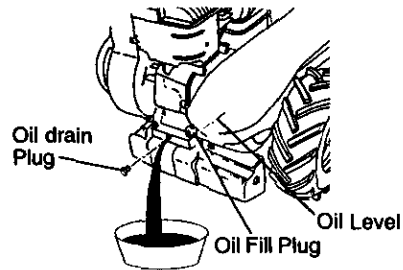

AIR FILTER

Your engine will not run properly using a dirty air filter. Clean the foam pre-cleaner after every 50 hours of operation or every season. Service paper cartridge every 100 hours of operation or every season, whichever occurs first.

Service air cleaner more often under dusty conditions.

1. Remove knob and cover. Lift air cleaner assembly off stud.

TO SERVICE PRE-CLEANER

2. Remove foam pre-cleaner from air filter.
 3. Wash it in liquid detergent and water.
 4. Squeeze it dry in a clean cloth.
- NOTE:** If very dirty or damaged, replace pre-cleaner.
5. Reinstall pre-cleaner onto air filter.
 6. Reinstall cover and secure with knob.

TO SERVICE CARTRIDGE

1. Carefully remove cartridge to prevent debris from entering carburetor. Clean base carefully to prevent debris from entering carburetor.
 2. Remove foam pre-cleaner from air filter.
 3. Clean cartridge by tapping gently on flat surface. If very dirty or damaged, replace cartridge.
 4. Reinstall pre-cleaner onto air filter.
 5. Reinstall cover and secure with knob.
- IMPORTANT:** Petroleum solvents, such as kerosene, are not to be used to clean the cartridge. They may cause deterioration of the cartridge. Do not oil cartridge. Do not use pressurized air to clean or dry cartridge.

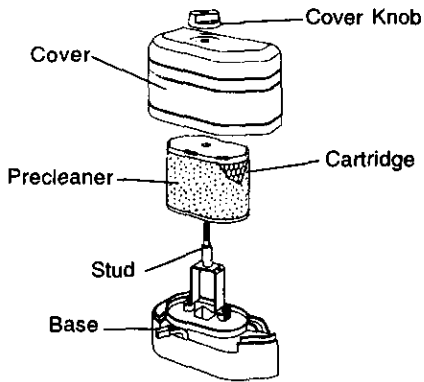

COOLING SYSTEM

Your engine is air cooled. For proper engine performance and long life keep your engine clean.

- Clean air screen frequently using a stiff-bristled brush.
- Remove blower housing and clean as necessary.
- Keep cylinder fins free of dirt and chaff.

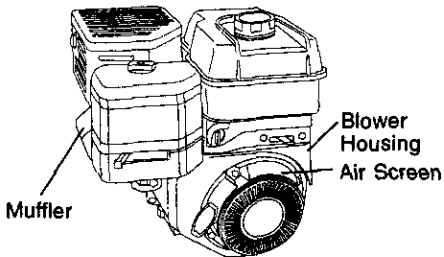

MUFFLER

Do not operate tiller without muffler. Do not tamper with exhaust system. Damaged mufflers or spark arresters could create a fire hazard. Inspect periodically and replace if necessary. If your engine is equipped with a spark arrester screen assembly, remove every 50 hours for cleaning and inspection. Replace if damaged.

SPARK PLUG

Replace spark plugs at the beginning of each tilling season or after every 50 hours of use, whichever comes first. Spark plug type and gap setting is shown in "PRODUCT SPECIFICATIONS" on page 4 of this manual.

TRANSMISSION

Once a season, lubricate the right hand gear case grease fitting with 1 oz. of EP #1 grease.

CLEANING

Do not clean your tiller when the engine and transmission are hot. We do not recommend using pressurized water (garden hose, etc.) to clean your unit unless the gasket area around the transmission and the engine muffler, air filter and carburetor are covered to keep water out. Water in engine will shorten the useful life of your tiller.

- Clean engine, wheels, finish, etc. of all foreign matter.
- Keep finished surfaces and wheels free of all gasoline, oil, etc.
- Protect painted surfaces with automotive type wax.

SERVICE AND ADJUSTMENTS

CAUTION: Disconnect spark plug wire from spark plug and place wire where it cannot come into contact with plug.

TILLER

TO ADJUST HANDLE HEIGHT

Select handle height best suited for your tilling conditions. Handle height will be different when tiller digs into soil.

1. First loosen handle lock lever.
2. Handle can be positioned at different settings between "HIGH" and "LOW" positions.
3. Retighten handle lock lever securely after adjusting.

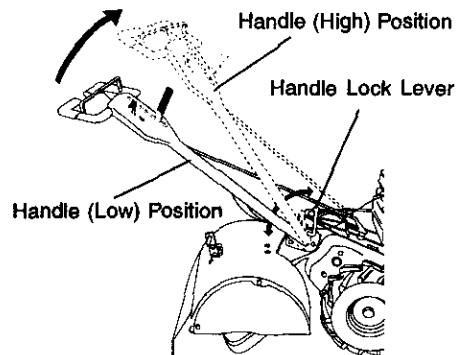

TIRE CARE

CAUTION: When mounting tires, unless beads are seated, overinflation can cause an explosion.

- Maintain 20 pounds of tire pressure. If tire pressures are not equal, tiller will pull to one side.
- Keep tires free of gasoline or oil which can damage rubber.

TO REMOVE WHEEL

1. Place blocks under transmission to keep tiller from tipping.
2. Remove hairpin clip and clevis pin from wheel.
3. Remove wheel and tire.
4. Repair tire and reassemble.

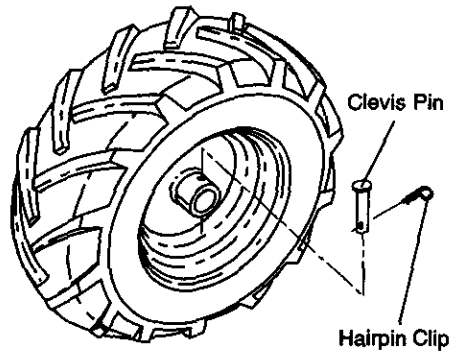

TO REMOVE BELT GUARD

NOTE: For ease of removal, remove hairpin clip and clevis pin from left wheel. Pull wheel out from tiller about 1 inch.

1. Remove two (2) screws from side of belt guard.
2. Remove hex nut and washer from bottom of belt guard (located behind wheel).
3. Pull belt guard out and away from unit.
4. Replace belt guard by reversing above procedure.

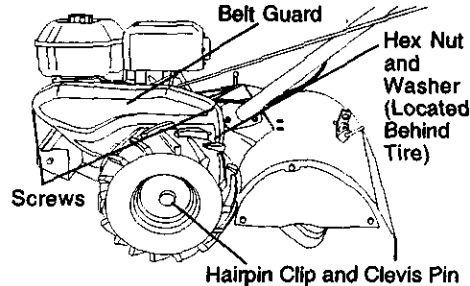

TO REPLACE GROUND DRIVE BELT

1. Remove belt guard as described in "TO REMOVE BELT GUARD".
2. Remove old belt by slipping off engine pulley first then remove from transmission pulley.
3. Place new belt in groove of transmission pulley and into engine pulley. **BELT MUST BE IN GROOVE ON TOP OF IDLER PULLEY. NOTE POSITION OF BELT TO GUIDES.**
4. Check belt adjustment as described below.
5. Replace belt guard.
6. Reposition wheel and replace clevis pin and hairpin clip.

GROUND DRIVE BELT ADJUSTMENT

For proper belt tension, the extension spring should have about 5/8 inch stretch when drive control bar is in "ENGAGED" position. This tension can be attained as follows:

1. Loosen cable clip screw securing the drive control cable.
2. Slide cable forward for less tension and rearward for more tension until about 5/8 inch stretch is obtained while the drive control bar is engaged.
3. Tighten cable clip screw securely.

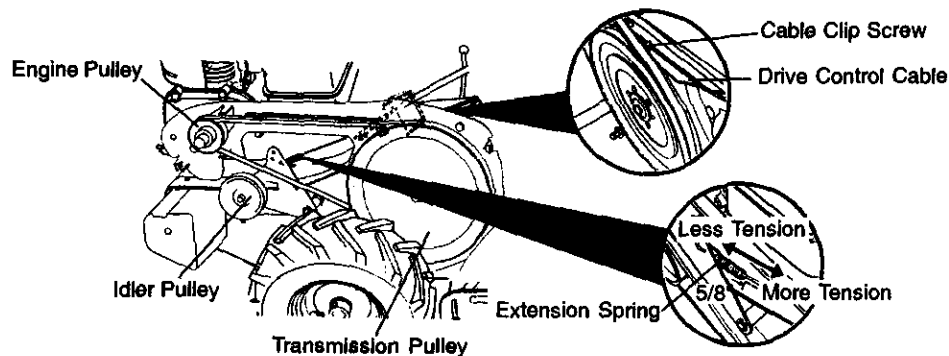

TINE REPLACEMENT

CAUTION: Tines are sharp. Wear gloves or other protection when handling tines.

A badly worn tine causes your tiller to work harder and dig more shallow. Most important, worn tines cannot chop and shred organic matter as effectively nor bury it as deeply as good tines. A tine this worn needs to be replaced.

- To maintain the superb tilling performance of this machine the tines should be checked for sharpness, wear, and bending, particularly the tines which are next to the transmission. If the gap between the tines exceeds 3-1/2 inches they should be replaced or straightened as necessary.
- New tines should be assembled. Sharpened tine edges will rotate rearward from above.

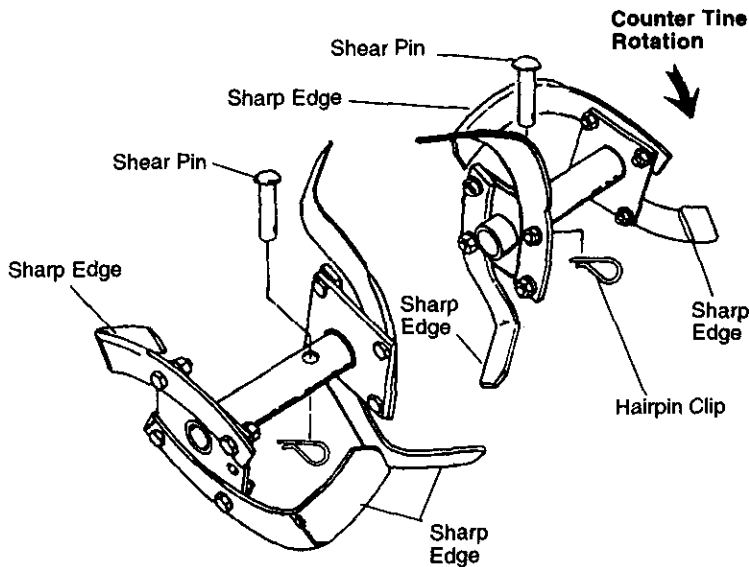
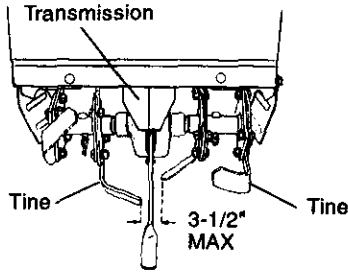
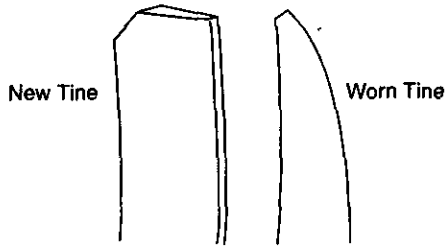

ENGINE

Maintenance, repair, or replacement of the emission control devices and systems, which are being done at the customer's expense, may be performed by any non-road engine repair establishment or individual. Warranty repairs must be performed by an authorized engine manufacturer's service outlet.

TO ADJUST THROTTLE CONTROL CABLE

1. The throttle control has been preset at the factory and adjustment should not be necessary. If adjustment is necessary, proceed as follows:
2. With engine not running, move remote throttle control lever to "FAST" position.
3. If throttle lever on engine touches high speed stop, no further adjustment is necessary. If throttle lever does not touch high speed stop, continue with adjustment procedure.
4. Loosen cable clamp screw.
5. Move throttle lever up until it touches high speed stop, and hold in this position.
6. Tighten cable clamp screw securely.

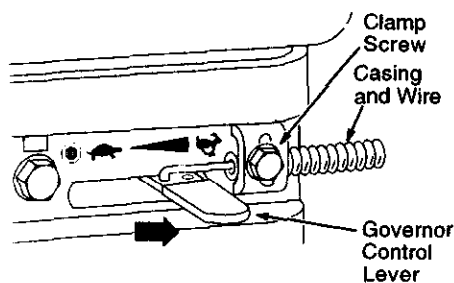

TO ADJUST CARBURETOR

The carburetor has been preset at the factory and adjustment should not be necessary. However, engine performance can be affected by differences in fuel, temperature, altitude or load. If the carburetor does need adjustment, contact your nearest authorized service center/department.

IMPORTANT: Never tamper with the engine governor, which is factory set for proper engine speed. Overspeeding the engine above the factory high speed setting can be dangerous. If you think the engine-governed high speed needs adjusting, contact your nearest authorized service center/department, which has the proper equipment and experience to make any necessary adjustments.

STORAGE

Immediately prepare your tiller for storage at the end of the season or if the unit will not be used for 30 days or more.

CAUTION: Never store the tiller with gasoline in the tank inside a building where fumes may reach an open flame or spark. Allow the engine to cool before storing in any enclosure.

TILLER

1. Clean entire tiller (See "CLEANING" in the Maintenance section of this manual).
2. Inspect and replace belts, if necessary (See belt replacement instructions in the Service and Adjustments section of this manual).
3. Lubricate as shown in the Maintenance section of this manual.
4. Be sure that all nuts, bolts and screws are securely fastened. Inspect moving parts for damage, breakage and wear. Replace if necessary.
5. Touch up all rusted or chipped paint surfaces; sand lightly before painting.

ENGINE

FUEL SYSTEM

IMPORTANT: It is important to prevent gum deposits from forming in essential fuel system parts such as the carburetor, fuel filter, fuel hose, or tank during storage. Also, experience indicates that alcohol blended fuels (called gasohol or using ethanol or methanol) can attract moisture which leads to separation and formation of acids during storage. Acidic gas can damage the fuel system of an engine while in storage.

1. Drain the fuel tank.
 2. Start the engine and let it run until the fuel lines and carburetor are empty.
- Never use engine or carburetor cleaner products in the fuel tank or permanent damage may occur.
 - Use fresh fuel next season.

NOTE: Fuel stabilizer is an acceptable alternative in minimizing the formation of fuel gum deposits during storage. Add stabilizer to gasoline in fuel tank or storage container. Always follow the mix ratio found on stabilizer container. Run engine at least 10 minutes after adding stabilizer to allow the stabilizer to reach the carburetor. Do not drain the gas tank and carburetor if using fuel stabilizer.

ENGINE OIL

Drain oil (with engine warm) and replace with clean oil. (See "ENGINE" in the Maintenance section of this manual).

CYLINDER

1. Remove spark plug.
2. Pour 1 ounce (29 ml) of oil through spark plug hole into cylinder.
3. Pull starter handle slowly several times to distribute oil.
4. Replace with new spark plug.

OTHER

- Do not store gasoline from one season to another.
- Replace your gasoline can if your can starts to rust. Rust and/or dirt in your gasoline will cause problems.
- If possible, store your unit indoors and cover it to give protection from dust and dirt.
- Cover your unit with a suitable protective cover that does not retain moisture. Do not use plastic. Plastic cannot breathe which allows condensation to form and will cause your unit to rust.

IMPORTANT: Never cover tiller while engine and exhaust areas are still warm.

TROUBLE SHOOTING

PROBLEM	CAUSE	CORRECTION
Will not start	<ol style="list-style-type: none"> 1. Out of fuel. 2. Engine not "CHOKED" properly. 3. Engine flooded. 4. Dirty air cleaner. 5. Water in fuel. 6. Clogged fuel tank. 7. Loose spark plug wire. 8. Bad spark plug or improper gap. 9. Carburetor out of adjustment. 10. Oil soaked air filter. 	<ol style="list-style-type: none"> 1. Fill fuel tank. 2. See "TO START ENGINE" in the Operation section. 3. Wait several minutes before attempting to start. 4. Clean or replace air cleaner cartridge. 5. Drain fuel tank and carburetor, and refill tank with fresh gasoline. 6. Remove fuel tank and clean. 7. Make sure spark plug wire is seated properly on plug. 8. Replace spark plug or adjust gap. 9. Make necessary adjustments. 10. Replace air filter.
Hard to start	<ol style="list-style-type: none"> 1. Throttle control not set properly. 2. Dirty air cleaner. 3. Bad spark plug or improper gap. 4. Stale or dirty fuel. 5. Loose spark plug wire. 6. Carburetor out of adjustment. 	<ol style="list-style-type: none"> 1. Place throttle control in "FAST" position. 2. Clean or replace air cleaner cartridge. 3. Replace spark plug or adjust gap. 4. Drain fuel tank and refill with fresh gasoline. 5. Make sure spark plug wire is seated properly on plug. 6. Make necessary adjustments.
Loss of power	<ol style="list-style-type: none"> 1. Engine is overloaded. 2. Dirty air cleaner. 3. Low oil level/dirty oil. 4. Faulty spark plug. 5. Oil in fuel. 6. Stale or dirty fuel. 7. Water in fuel. 8. Clogged fuel tank. 9. Spark plug wire loose. 10. Dirty engine air screen. 11. Dirty/clogged muffler. 12. Carburetor out of adjustment. 13. Poor compression. 	<ol style="list-style-type: none"> 1. Set depth stake and wheels for shallower tilling. 2. Clean or replace air cleaner cartridge. 3. Check oil level/change oil. 4. Clean and regap or change spark plug. 5. Drain and clean fuel tank and refill, and clean carburetor. 6. Drain fuel tank and refill with fresh gasoline. 7. Drain fuel tank and carburetor, and refill tank with fresh gasoline. 8. Remove fuel tank and clean. 9. Connect and tighten spark plug wire. 10. Clean engine air screen. 11. Clean/replace muffler. 12. Make necessary adjustments. 13. Contact a Sears or other qualified service center.

PROBLEM	CAUSE	CORRECTION
Engine overheats	<ol style="list-style-type: none"> 1. Low oil level/dirty oil. 2. Dirty engine air screen. 3. Dirty engine. 4. Partially plugged muffler. 5. Improper carburetor adjustment. 	<ol style="list-style-type: none"> 1. Check oil level/change oil. 2. Clean engine air screen. 3. Clean cylinder fins, air screen, muffler area. 4. Remove and clean muffler. 5. Adjust carburetor to richer position.
Excessive bounce/difficult handling	<ol style="list-style-type: none"> 1. Ground too dry and hard. 	<ol style="list-style-type: none"> 1. Moisten ground or wait for more favorable soil conditions.
Soil balls up or clumps	<ol style="list-style-type: none"> 1. Ground too wet. 	<ol style="list-style-type: none"> 1. Wait for more favorable soil conditions.
Engine runs but tiller won't move	<ol style="list-style-type: none"> 1. Tine control is not engaged. 2. V-belt not correctly adjusted. 3. V-belt is off pulley(s). 	<ol style="list-style-type: none"> 1. Engage tine control. 2. Inspect/adjust V-belt. 3. Inspect V-belt.
Engine runs but labors when tilling	<ol style="list-style-type: none"> 1. Tilling too deep. 2. Throttle control not properly adjusted. 3. Carburetor out of adjustment. 	<ol style="list-style-type: none"> 1. Set depth stake for shallower tilling. 2. Check throttle control setting. 3. Make necessary adjustments.
Tines Skip over ground	<ol style="list-style-type: none"> 1. Shear pin (s) broken. 	<ol style="list-style-type: none"> 1. Replace shear pin(s).
Hard to Shift into gear	<ol style="list-style-type: none"> 1. Gears not timed. 	<ol style="list-style-type: none"> 1. Briefly engage drive control bar and release or rock tiller forward and backward until are able to shift gears.
Tiller shuts off when drive control bar engaged	<ol style="list-style-type: none"> 1. Shift lever set in between counter rotating till position and forward rotating till position. 2. Tines jammed. 	<ol style="list-style-type: none"> 1. Shift to either counter rotating till position or forward rotating till position. 2. Clear tines.

REPAIR PARTS

TILLER -- MODEL NUMBER 917.293470

HANDLES

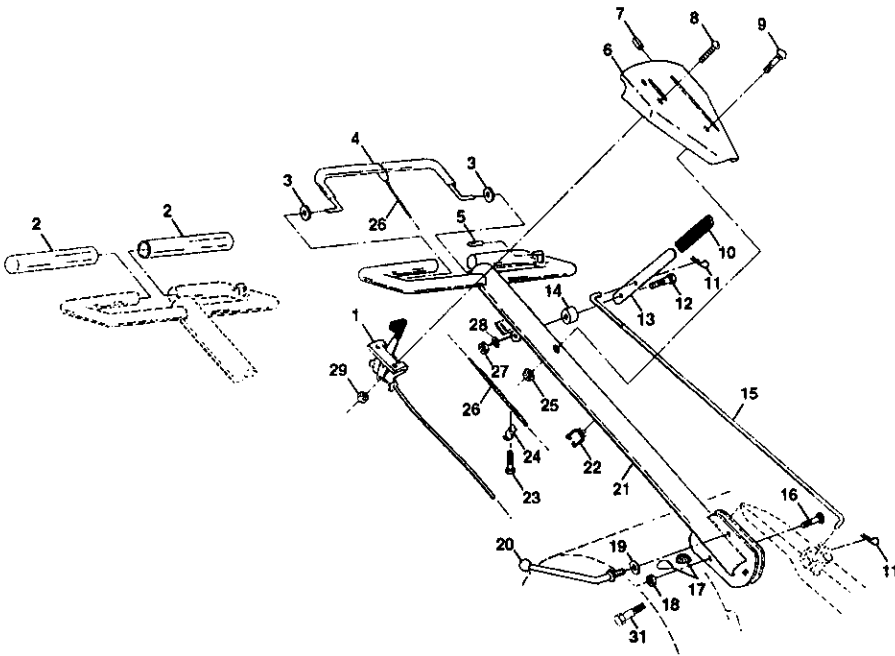

KEY PART NO. NO.	DESCRIPTION
1	175250 Throttle, Control
2	141406 Grip, Handle
3	110673X Grommet, Handle
4	127254X Bar, Drive Control Assembly
5	6712J Cap, Vinyl
6	137119 Panel, Control
7	110641X Bushing, Split
8	71191008 Screw, Pan Head #10-24
9	72010520 Bolt, 5/16-18 x 2-1/2
10	110646X Handle, Grip
11	STD624003 Clip, Hairpin
12	81328 Bolt, Shoulder
13	110741X Handle, Shift
14	109313X Grommet, Rubber
15	110702X Rod, Shift
16	STD533710 Bolt, Carriage 3/8-16 x 1 Gr. 5
17	109229X Lock, Handle

KEY PART NO. NO.	DESCRIPTION
18	STD541437 Nut, Crownlock 3/8-16
19	19131611 Washer 13/32 x 1 x 11 Ga.
20	109228X Lever, Lock, Handle
21	150258 Handle, Assemble
22	165197 Clip, Plastic, Cable
23	86777 Screw, Hex, Washer Hd, Slotted #10-24 x 1/2
24	9484R Clip
25	73970500 Locknut, Hex, Flange
26	110675X Clutch, Cable
27	73900400 Nut, Hex Flange 1/4-20
29	STD541462 Nut, Keps #10-24
31	150696 Bolt, Pivot

NOTE: All component dimensions given in U.S. inches. 1 inch = 25.4 mm

TILLER -- MODEL NUMBER 917.293470
MAINFRAME, LEFT SIDE

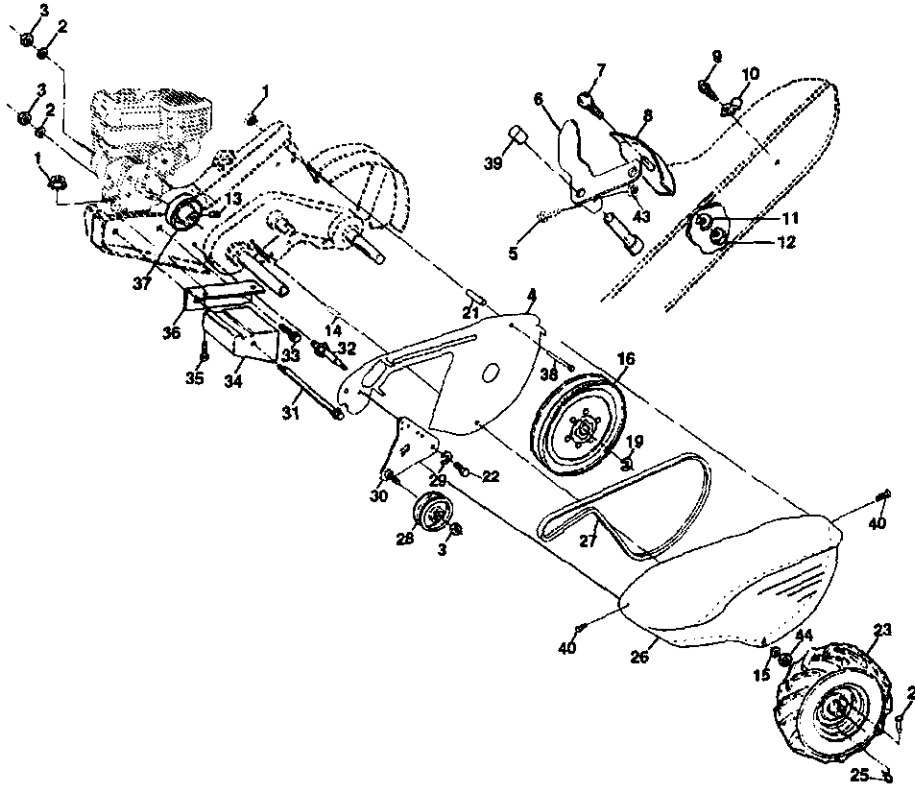

**KEY PART
 NO. NO.**

NO.	NO.	DESCRIPTION
1	STD541431	Nut, Keps Flange 5/16-18
2	STD551137	Washer, Lock 3/8
3	STD541037	Nut, Hex 3/8-16
4	170127	Shield, Inner Belt Guard
5	154734	Screw Shift Lever
6	110111X	Lever, Shift
7	STD532505	Bolt, Carriage 1/4-20 x 1/2 Gr. 5
8	8700J	Plate, Shift Indicator
9	86777	Screw, Hex, Washer Head, Slotted #10-24 x 1/2
10	9484R	Clip
11	STD551125	Washer, Lock 1/4
12	STD541025	Nut, Hex 1/4-20
13	23230506	Screw, Set, 5/16-18 x 3/8
14	110652X	Spacer, Split .327 x .42 x 2.09
15	STD551031	Washer 11/32 x 11/16 x 16 Ga.
16	145102	Sheave, Transmission
19	12000028	Ring, Retainer
21	156117	Spacer, Split .327 x .42 x 1.220
22	74770508	Bolt, Fin Hex 5/16-24 x 1/2
23	102190X	Tire
	150750	Fin
	795R	Tire Valve
24	126875X	Rivet, Drilled

**KEY PART
 NO. NO.**

NO.	NO.	DESCRIPTION
25	STD624003	Clip, Hairpin
26	165501X558	Guard, Belt
27	132801	Belt, V
28	104679X	Pulley, Idler
29	12000032	Ring, Klip
30	159229	Bracket, Idler
31	102194X	Bolt, Hex 5/16-16 x 10
32	102141X	Shaft, Idler Arm
33	STD523710	Bolt, Hex 3/8-16 x 1
34	102173X	Counterweight, L.H.
35	74760524	Bolt, Hex 5/16-18 x 1-1/2
36	102331X	Bracket, Reinforcement, L.H.
37	130812	Sheave, Engine
38	74760544	Bolt, Fin Hex 5/16-18 x 2-3/4
39	140062	Cap, Plunger
40	170488	Screw Hex Wash. Hd #10-32 x 9/16
43	69180	Nut Lock #10-24
44	73800500	Nut, Lock Hex w/Ins 5/16-18

NOTE: All component dimensions given in U.S. inches. 1 inch = 25.4 mm

TILLER -- MODEL NUMBER 917.293470
MAINFRAME, RIGHT SIDE

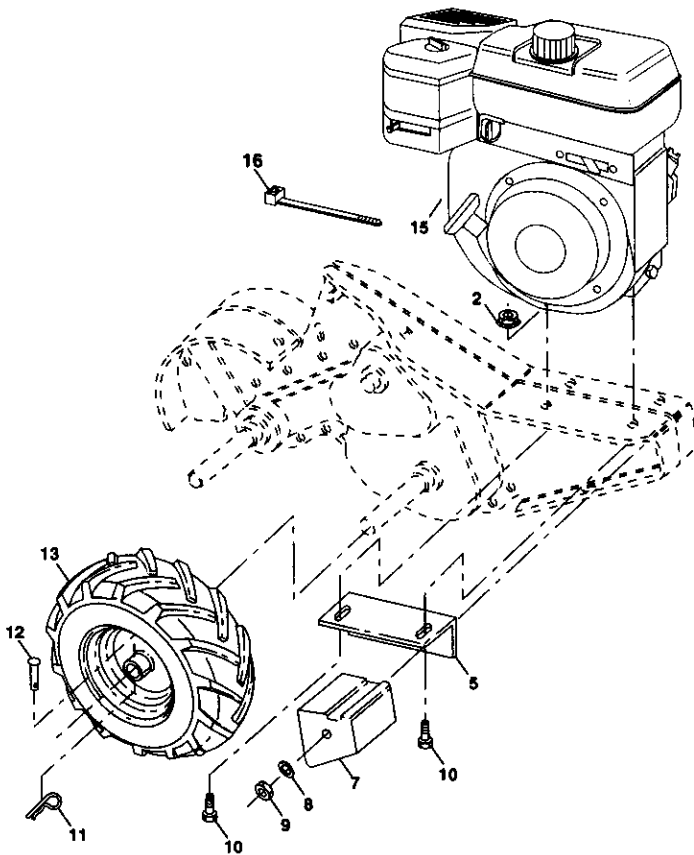

KEY PART NO.	NO.	DESCRIPTION
2	73970500	Locknut, Hex, Flange 5/16-18
5	102332X	Bracket, Reinforcement
7	102173X	Counter Weight, R.H.
8	STD551137	Washer, Lock 3/8
9	STD541037	Nut, Hex 3/8-16
10	74760524	Bolt, Hex 5/16-18 x 1-1/2
11	STD624003	Clip, Hairpin
12	126875X	Rivet, Drilled

KEY PART NO.	NO.	DESCRIPTION
13	102190X	Tire
	150750	Pin
	795R	Tire Valve
15	-----	Engine, (See Breakdown) Craftsman Model No. 110402-0180-E1
16	7192J	Tie Cable

NOTE: All component dimensions given in U.S.Inches.
 1 Inch = 25.4 mm

TILLER -- MODEL NUMBER 917.293470

TRANSMISSION

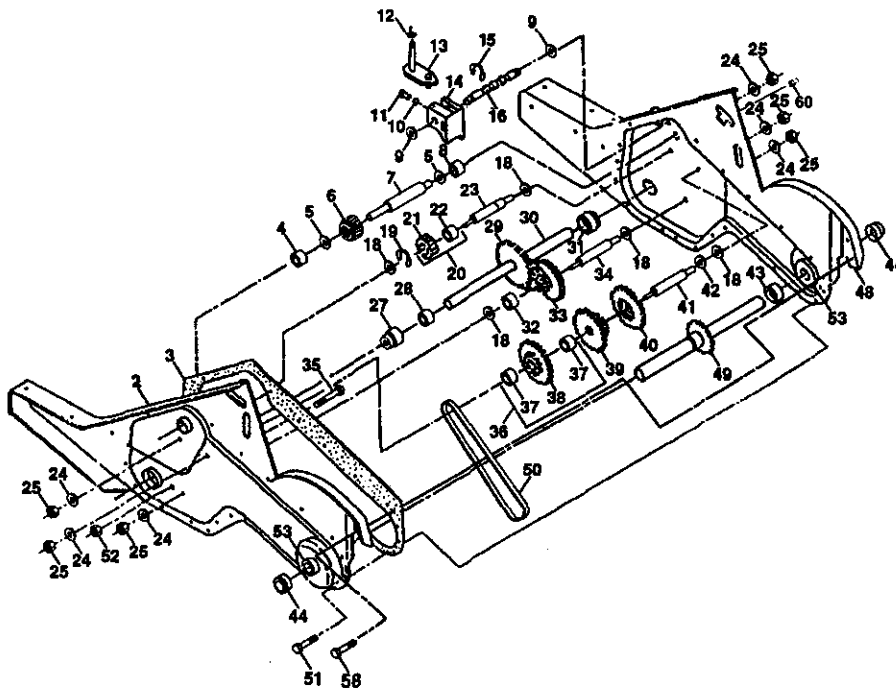

KEY PART NO. NO.	DESCRIPTION	KEY PART NO. NO.	DESCRIPTION
1	170337	32	106388X
	Transmission Assembly (Includes		Spacer 0.70 x 1.00 x 1.150
	Key Nos. 2-52)	33	102121X
2	165729		Sprocket and Gear Assembly
	Gearcase, L.H. w/Bearing	34	102112X
	(Includes Key No. 4)		Shaft, Reduction (2nd)
3	161963	35	102101X
	Gasket, Gearcase		Screw, Whiz, Lock 5/16-18 x 3-1/2
4	5020J	36	154355
	Bearing, Needle		Sprocket Assembly w/Bearing
5	1370H		(Includes Key Nos. 37 and 38)
	Washer, Thrust 5/8 x 1.10 x 1/32	37	4422J
6	137335		Bearing, Needle
	Pinion, Input	38	154356
7	145101		Sprocket, Tine
	Shaft, Input	39	105345X
8	4895H		Gear, Cluster, Red 1st & 2nd
	Bearing, Needle	40	105346X
9	154467		Gear, Reverse
	Washer, Seal	41	8358J
10	7392M		Shaft, Reduction (1st)
	Ball, Steel	42	4220R
11	100371K		Washer, Thrust
	Spring, Shift, Fork	43	106146X
12	106160X		Spacer 1.01 x 1.75 x 0.760
	O-Ring	44	155236
13	142145		Seal Asm. Oil
	Arm, Shift	48	170338
14	8353J		Gearcase, R.H. w/Bearing
	Fork, Shift		(Includes Key No. 8)
15	12000039	49	132688
	Ring, Klip		Shaft, Tine
16	154466	50	106147X
	Shaft, Shift		Chain, Roller #50-50 Pitch
18	4358J	51	17720408
	Washer		Screw 1/4-20 x 1/2
19	12000040	52	STD541031
	Ring, Klip		Nut, Hex 5/16-18
20	102114X	53	165140
	Gear, Assembly, Reverse Idler		Bearing Kit, Tine Shaft
	(Includes Key Nos. 21 and 22)	58	17720412
21	102115X		Screw 1/4-20 x 3/4
	Gear, Reverse Idler	60	6855M
22	6803J	--	Fitting Grease
	Bearing, Needle		Grease, Plastilube #1
23	102111X		
	Shaft, Reverse Idler		
24	STD551143		
	Washer, Lock 7/16		
25	STD541143		
	Nut, Hex 7/16-20		
27	143009		
	Bearing, Shaft, Ground Drive L.H.		
28	106390X		
	Spacer 0.765 x 1.125 x 1.23		
29	102134X		
	Chain #35-50 Pitch		
30	150737		
	Ground Shaft Assembly		
31	143008		
	Bearing, Shaft, Ground Drive R.H.		

NOTE: All component dimensions given in U.S.inches.
1 Inch = 25.4 mm

TILLER -- MODEL NUMBER 917.293470

TINE SHIELD

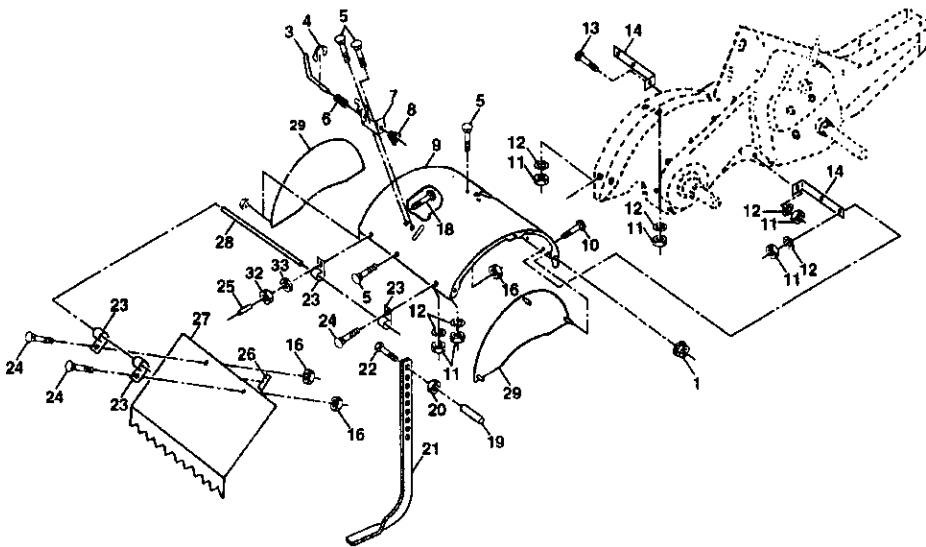

KEY PART NO.	NO.	DESCRIPTION
1	73900500	Nut, Lock Hex Flange 5/16-18 Unc
3	8393J	Pin, Stake, Depth
4	12000036	Ring, Klip
5	STD533107	Bolt, Carriage 5/16-18 x 3/4 Gr 5
6	8394J	Spring
7	8392J	Bracket, Latch
8	109230X	Spring, Depth Stake
9	102152X558	Shield, Tine
10	72140508	Bolt, Rehd Sqnk 5/16-18 Unc x 1
11	STD541031	Nut, Hex 5/16-18
12	STD551131	Washer, Lock 5/16
13	STD533112	Bolt, Carriage 5/16-18 x 1-1/4
14	124343	Bracket, Shield Tine
16	73900400	Nut, Flange lock 1/4-20
18	STD532512	Bolt, Carriage 1/4-20 x 1-1/4 Gr. 5
19	102701X	Grip

KEY PART NO.	NO.	DESCRIPTION
20	STD541037	Nut, Hex 3/8-16
21	102156X	Stake, Depth
22	74930632	Bolt, Hex 3/8-16 x 2
23	4440J	Hinge
24	STD532505	Bolt, Carriage 1/4-20 x 1/2
25	6712J	Cap, Vinyl
26	109227X	Pad, Idler
27	102686X558	Shield, Levelling
28	120588X	Pin, Hinge
29	104085X558	Shield, Side
32	STD541025	Nut, Fin, Hex 1/4-20
33	STD551125	Washer Lock Hvy Helcal 1/4

NOTE: All component dimensions given in U.S. inches
1 inch = 25.4 mm

TILLER -- MODEL NUMBER 917.293470

TINE ASSEMBLY

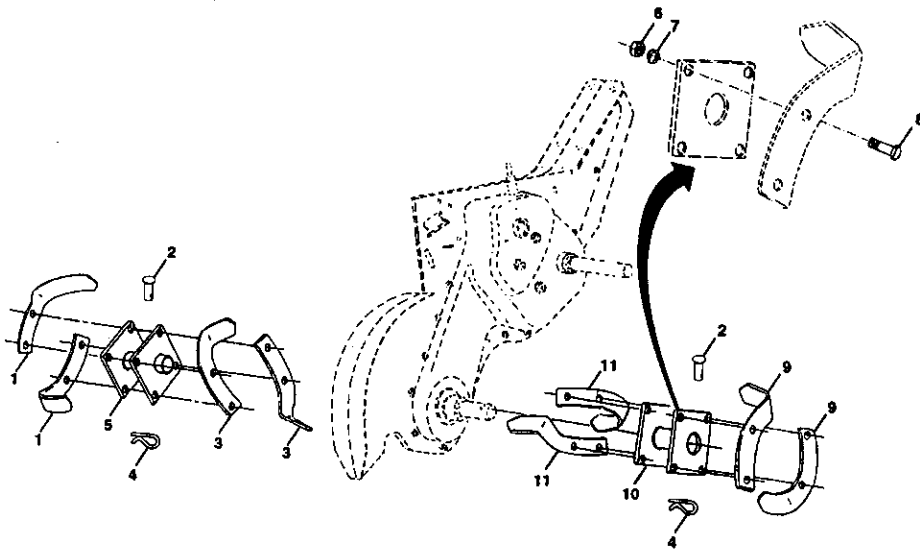

KEY PART NO.	DESCRIPTION
4459J	Tine, Outer, L.H.
132673	Pin, Shear
6554J	Tine, Inner, L.H.
3146R	Clip, Hairpin
132721	Assembly, Hub and Plate, L.H.
73610600	Nut, Hex 3/8-24
STD551137	Washer, Lock 3/8

KEY PART NO.	DESCRIPTION
8	74610616 Bolt, Hex 3/8-24 x 1
9	4460J Tine, Outer, R.H.
10	132722 Assembly, Hub and Plate, R.H.
11	6555J Tine, Inner, R.H.

NOTE: All component dimensions given in U.S. inches.
1 inch = 25.4 mm

DECALS

TILLER -- MODEL NUMBER 917.293470

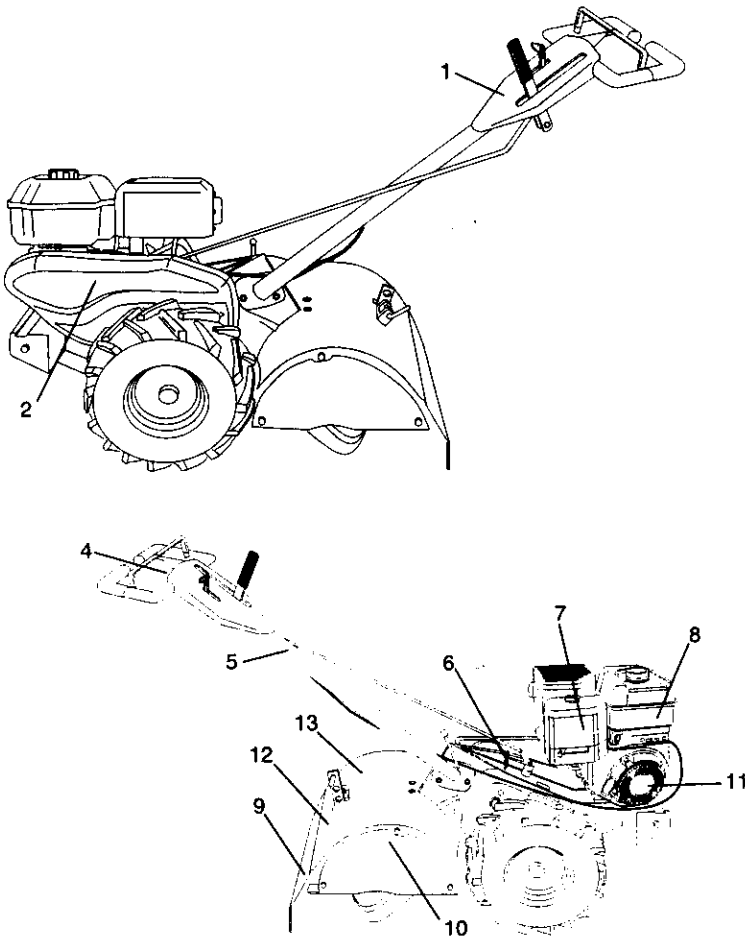

KEY PART NO.	PART NO.	DESCRIPTION
1	176738	Decal, Service CNTRL PNL
2	176736	Decal, Belt Guard
4	137538	Decal, Caution, Drive Control
5	120431X	Decal, Hand Placement
6	102180X	Decal, Shift Indicator
7	166138	Decal, Operation Intek
8	167156	Decal, B & S Intek
9	120075X	Decal, Warning, Rotating Tines
10	157984	Decal, Tine, Shield, Counter Rotating Tines
11	171078	Decal, Rewind Intek
12	162215	Decal, Tine, Shield, Warning Dom
13	163094	Decal, Tine Depth Stake
--	176753	Manual, Owner's (Eng/Span)

TILLER -- MODEL NUMBER 917.293470
ENGINE, BRIGGS & STRATTON -- MODEL NUMBER 110402-0180-E1

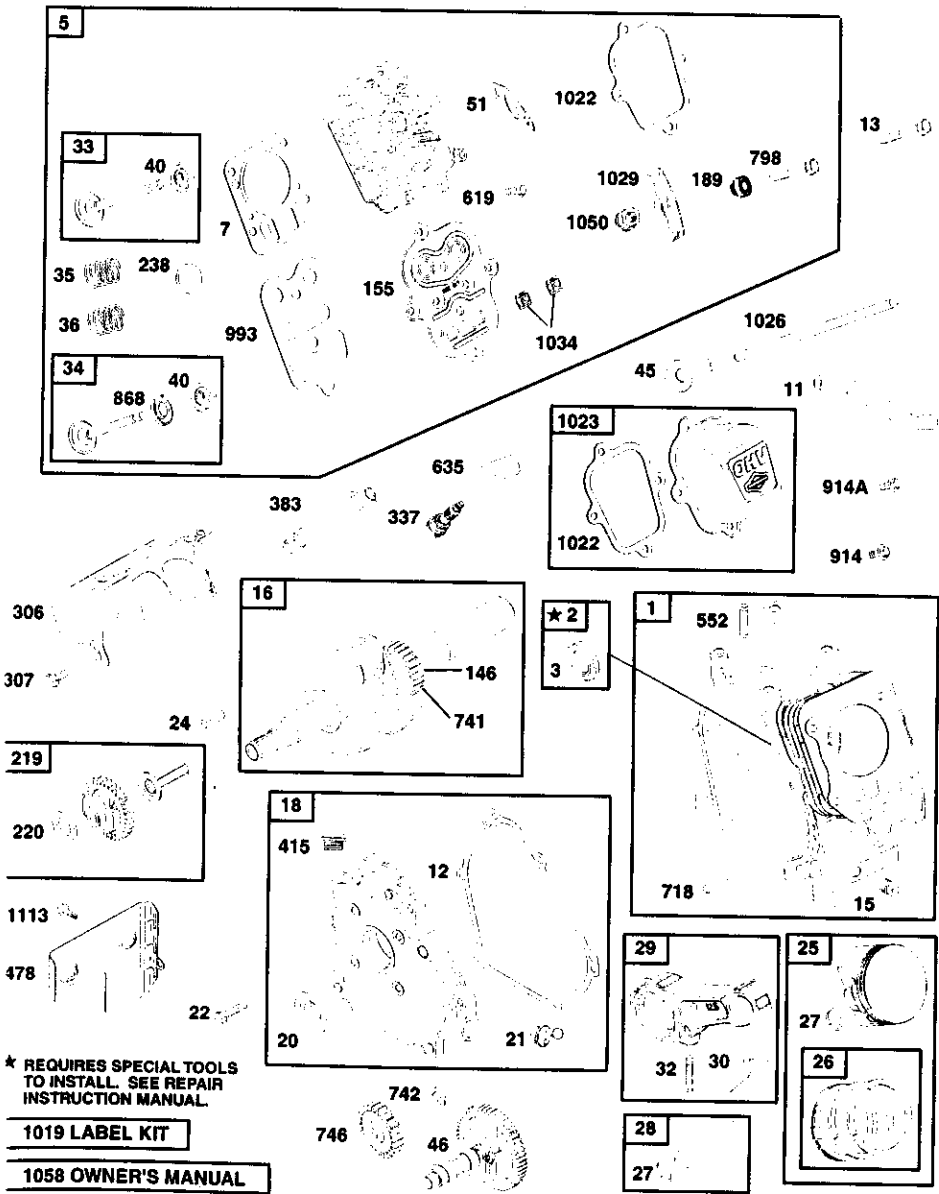

**TILLER -- MODEL NUMBER 917.293470
ENGINE, BRIGGS & STRATTON -- MODEL NUMBER 110402-0180-E1**

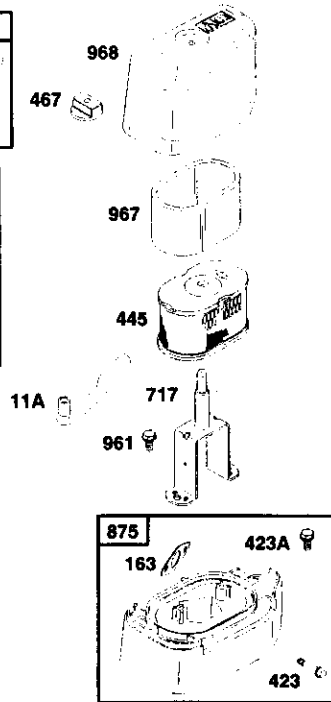
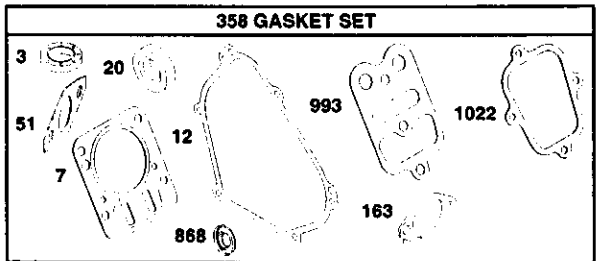
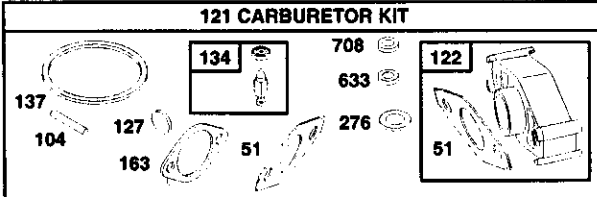
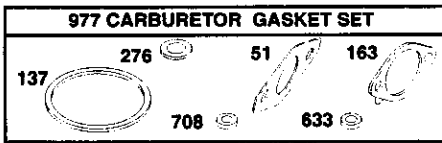
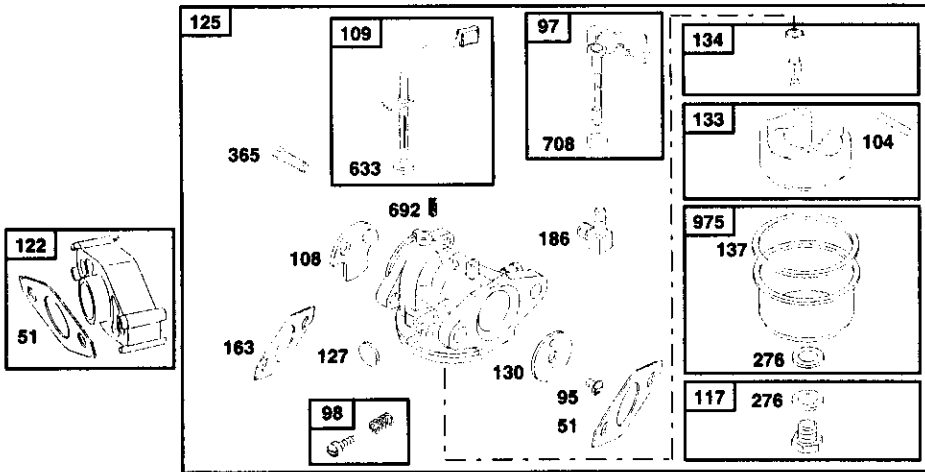

**TILLER -- MODEL NUMBER 917.293470
ENGINE, BRIGGS & STRATTON -- MODEL NUMBER 110402-0180-E1**

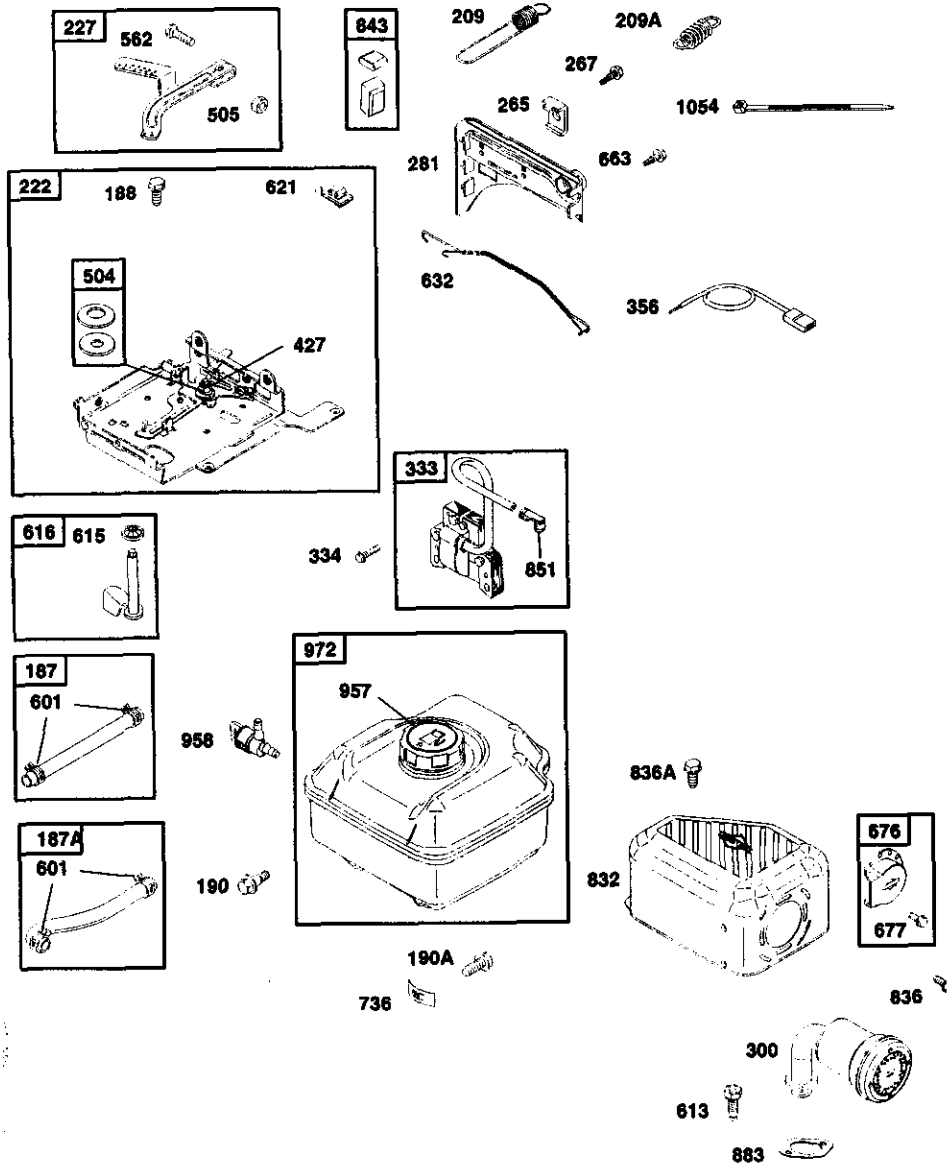

TILLER -- MODEL NUMBER 917.293470
ENGINE, BRIGGS & STRATTON -- MODEL NUMBER 110402-0180-E1

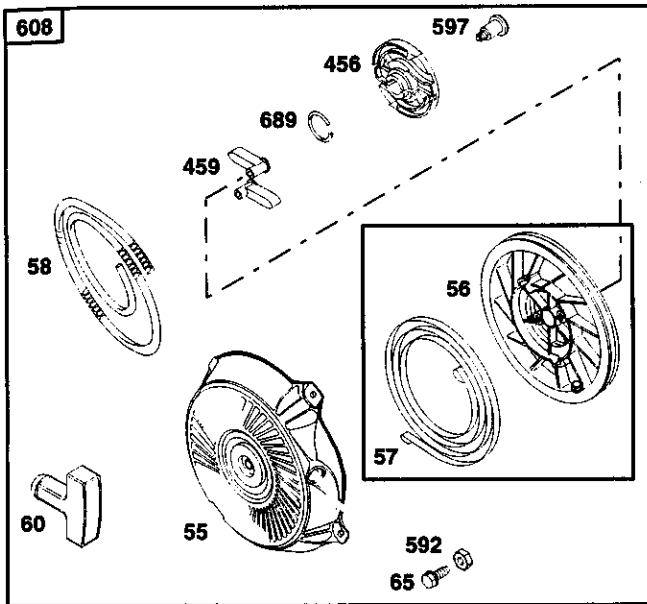

1036 EMISSIONS LABEL

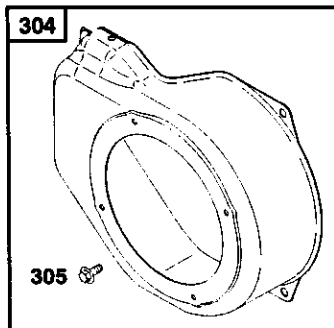
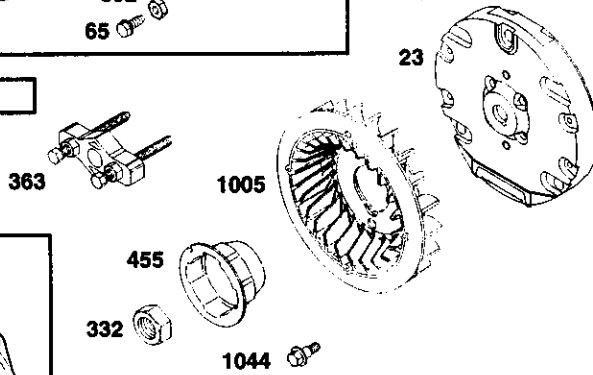

1033 VALVE OVERHAUL KIT

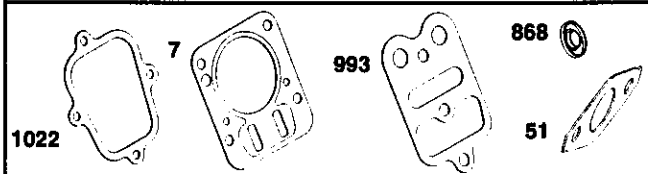

TILLER -- MODEL NUMBER 917.293470
ENGINE, BRIGGS & STRATTON -- MODEL NUMBER 110402-0180-E1

KEY NO.	PART NO.	DESCRIPTION	KEY NO.	PART NO.	DESCRIPTION
1	693811	Cylinder Assembly	125	694112	Carburetor
2	399269	Bushing/Seal Kit	127	223472	Ø Welch Plug
3	299819	• Oil Seal	130	691181	Throttle Valve
5	693643	Cylinder Head	133	398187	Carburetor Float
7	273489	+ Cylinder Head Gasket	134	398188	Ø Needle Valve
11	692600	Breather Tube	137	693981	Ø‡ Float Bowl Gasket
11A	693647	Breather Tube	146	94388	Timing Key
12	692549	• Crankcase Gasket	155	692556	Cylinder Head Plate
13	691137	Screw (Cylinder Head)	163	693458+‡	Ø‡ Air Cleaner Gasket
15	94916	Oil Drain Plug	186	493496	Hose Connector
16	693797	Crankshaft	187	492790	Fuel Line (Cut to Required Length)
18	694466	Crankcase Cover	187A	692601	Fuel Line (Molded)
20	692550	• Oil Seal	188	94644	Screw (Control Bracket)
21	281658	Oil Fill Cap	189	691295	Rocker Arm Ball
22	692551	Screw (Crankcase Cover)	190	692127	Screw (Fuel Tank)
23	692987	Flywheel	190A	94644	Screw (Fuel Tank)
24	222698	Flywheel Key	209	693710	Governor Spring
25	690021	Piston Assembly (Standard)	209A	261306	Governor Spring
	694167	Piston Assembly (.010" O/S)	219	693578	Governor Gear
	694168	Piston Assembly (.020" O/S)	220	221551	Washer (Governor Gear)
	694169	Piston Assembly (.030" O/S)	222	694253	Control Bracket
26	499631	Ring Set (Standard)	227	692573	Governor Lever
	692785	Ring Set (.010" O/S)	238	691300	Valve Cap
	692786	Ring Set (.020" O/S)	265	221535	Casing Clamp
	692787	Ring Set (.030" O/S)	267	692577	Screw (Casing Clamp)
27	263190	Piston Pin Lock	276	271716	Ø‡ Sealing Washer
28	499423	Piston Pin	281	694252	Control Panel
29	499424	Connecting Rod	300	693593	Exhaust Muffler
30	692562	Connecting Rod Dipper	304	693621	Housing-Blower
32	94699	Screw (Connecting Rod)	305	692608	Screw (Blower Housing)
33	499642	Exhaust Valve	306	693610	Cylinder Shield
34	499641	Intake Valve	307	690345	Screw (Cylinder Shield)
35	691304	Valve Spring (Intake)	332	94877	Nut (Flywheel)
36	691304	Valve Spring (Exhaust)	333	692605	Armature-Magneto
40	93312	Valve Retainer	334	94731	Screw (Magneto Armature)
45	262679	Valve Tappet	337	491055	Sparkplug
46	693404	Camshaft	356	398808	Stop Wire
51	692555+‡	Ø‡ Intake Gasket (2 Required)	358	690031	Gasket Set
55	691422	Rewind Starter Housing	363	19069	Flywheel Puller
56	498144	Pulley/Spring Assembly	365	692568	Screw (Carburetor)
57	498144	Pulley/Spring Assembly			
58	693449	Starter Rope			
60	391101	Starter Rope Grip			
65	94904	Screw (Rewind Starter)			
95	94098	Screw (Throttle Valve)			
97	690024	Throttle Shaft			
98	398185	Idle Speed Kit			
104	691242	Ø Float Hinge Pin			
108	692567	Choke Valve			
109	693628	Choke Shaft			
117	493763	Main Jet			
121	690032	Carburetor Kit			
122	693749	Ø Carburetor Spacer			

RPM Settings: Low Speed: 1900-2100
High Speed: 3000-3200

- Included in Gasket Set, Ref Number 358.
- Ø Included in Carburetor Kit, Ref Number 121.
- ‡ Included in Carburetor Gasket Set, Ref Number 977.
- + Included in Valve Overhaul Kit, Ref Number 1033.

NOTE: All component dimensions given in U.S. inches 1 inch = 25.4 mm

TILLER -- MODEL NUMBER 917.293470
ENGINE, BRIGGS & STRATTON -- MODEL NUMBER 110402-0180-E1

KEY NO.	PART NO.	DESCRIPTION	KEY NO.	PART NO.	DESCRIPTION
383	19374	Spark Plug Wrench	832	693583	Muffler Guard
415	693463	Oil Fill Plug	836	94896	Screw (Muffler Guard)
423	690349	Screw (Air Cleaner Base)	836A	693624	Screw (Mounting)
423A	94929	Screw (Air Cleaner Base)	843	694061	Lever Sleeve
427	692575	Nut (Control Bracket)	851	493880	Sparkplug Terminal
445	690610	A/C Cartridge Filter	868	498592	*+ Valve Seal
455	692591	Flywheel Cup	875	693459	Air Cleaner Base
456	281503	Pawl Friction Plate	883	272309	Exhaust Gasket
459	281505	Ratchet Pawl	914	94786	Screw (Rocker Cover 7/16" Long)
467	493903	Air Cleaner Knob	914A	692557	Screw (Rocker Cover 3/8" Long)
478	693709	Panel			
504	495659	Washer Set			
505	231082	Nut (Governor Control Lever)	957	493988	Fuel Tank Cap
552	692346	Governor Crank Bushing	958	692586	Shutoff Valve
562	94852	Bolt (Governor Control Lever)	961	693598	Screw (Air Cleaner Bracket)
592	94908	Nut (Rewind Starter)	967	273356	Pre-Cleaner Filter
597	94943	Screw (Pawl Friction Plate)	968	693460	Air Cleaner Cover
601	95162	Hose Clamp	972	692587	Fuel Tank
608	497830	Rewind Starter	975	493640	Float Bowl
613	94706	Screw (Muffler)	977	690033	Carburetor Gasket Set
615	692576	Governor Shaft Retainer	993	691892	*+ Cylinder Head Plate Gasket
616	692547	Governor Crank	1005	692592	Fan-Flywheel
619	691108	Screw (Cylinder Head Plate)	1019	690035	Label Kit
621	396847	Stop Switch	1022	693790	*+ Rocker Cover Gasket
632	693408	Spring/Link (Mechanical Governor)	1023	499924	Rocker Cover
			1026	693517	Push Rod
633	693867	Ø‡ Washer (Choke Shaft)	1029	691230	Rocker Arm
635	805529	Spark Plug Boot	1033	690034	Valve Overhaul Kit
663	694593	Screw (Control Panel)	1034	691343	Push Rod Guide
676	393757	Muffler Deflector	1036	695041	Emissions Label
677	94896	Screw (Muffler Deflector)	1044	692590	Screw (Flywheel)
689	263073	Friction Spring	1050	692558	Nut (Rocker Arm)
692	690572	Detent Spring (Choke)	1054	280275	Cable Tie
708	691321	Washer (Throttle Shaft)	1058	273700	Owner's Manual
717	693462	Air Cleaner Bracket	1113	692577	Screw (Panel)
718	230192	Locating Pin	— —	121432-0036-E2	Replacement Engine
736	693560	Nut Clip			
741	263157	Timing Gear			
742	692564	Ring-Retaining			
746	692566	Gear-Idler			
798	692559	Screw (Rocker Arm)			

RPM Settings: Low Speed: 1900-2100
High Speed: 3000-3200

- * Included in Gasket Set, Ref Number 358.
- Ø Included in Carburetor Kit, Ref Number 121.
- ‡ Included in Carburetor Gasket Set, Ref Number 977.
- + Included in Valve Overhaul Kit, Ref Number 1033.

NOTE: All component dimensions given in U.S. inches 1 inch = 25.4 mm

Get it fixed, at your home or ours!

For repair of major brand appliances **in your own home...**
no matter who made it, no matter who sold it!

1-800-4-MY-HOMESM Anytime, day or night
(1-800-469-4663)

www.sears.com

To bring in products such as vacuums,
lawn equipment and electronics for repair, call for
the location of your nearest **Sears Parts & Repair Center.**

1-800-488-1222 Anytime, day or night

www.sears.com

For the replacement parts, accessories and owner's manuals
that you need to do-it-yourself, call **Sears PartsDirect**SM!

1-800-366-PART 6 a.m. – 11 p.m. CST,
(1-800-366-7278) 7 days a week

www.sears.com/partsdirect

To purchase or inquire about a Sears Service Agreement:

1-800-827-6655

7 a.m. – 5 p.m. CST, Mon. – Sat.

Para pedir servicio de reparación a domicilio,
y para ordenar piezas con entrega a domicilio:

1-888-SU-HOGARSM
(1-888-784-8427)

Au Canada pour service en français:

1-877-LE-FOYERSM
(1-877-533-6937)



© Sears, Roebuck and Co.

® Registered Trademark / TM Trademark of Sears, Roebuck and Co.
® Marca Registrada / TM Marca de Fábrica de Sears, Roebuck and Co.

Free Manuals Download Website

<http://myh66.com>

<http://usermanuals.us>

<http://www.somanuals.com>

<http://www.4manuals.cc>

<http://www.manual-lib.com>

<http://www.404manual.com>

<http://www.luxmanual.com>

<http://aubethermostatmanual.com>

Golf course search by state

<http://golfingnear.com>

Email search by domain

<http://emailbydomain.com>

Auto manuals search

<http://auto.somanuals.com>

TV manuals search

<http://tv.somanuals.com>