

SEARS

CRAFTSMAN[®]

MODELO NO. 917.377210

MANUAL DEL DUEÑO

EZ³

- **Assembly**
- **Operation**
- **Customer Responsibilities**
- **Service**
- **Adjustments**
- **Repair Parts**

Caution:
Read and Follow
all Safety Rules
and Instructions
Before Operating
This Equipment

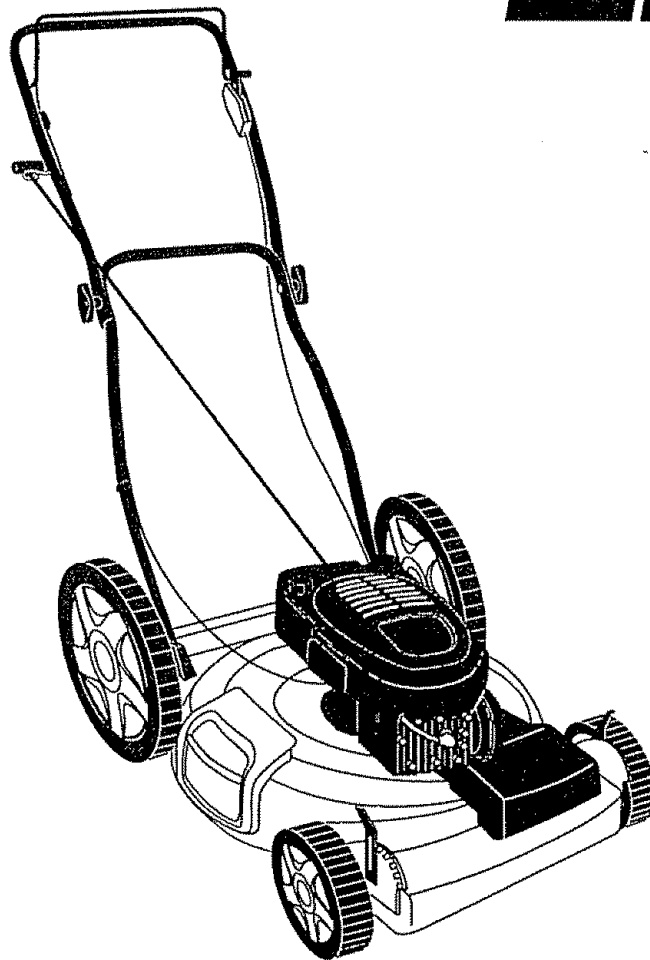

156525 REV.1 01.30.97 VBL

IMPRESO EN LOS ESTADOS UNIDOS

Sears, Roebuck and Co., Hoffman Estates, IL 60179 U.S.A.



SAFETY RULES



Safe Operation Practices for Walk-Behind Mowers

IMPORTANT: THIS CUTTING MACHINE IS CAPABLE OF AMPUTATING HANDS AND FEET AND THROWING OBJECTS. FAILURE TO OBSERVE THE FOLLOWING SAFETY INSTRUCTIONS COULD RESULT IN SERIOUS INJURY OR DEATH. SAFETY STANDARDS REQUIRE OPERATOR PRESENCE CONTROLS TO MINIMIZE THE RISK OF INJURY. YOUR UNIT IS EQUIPPED WITH SUCH CONTROLS. DO NOT ATTEMPT TO DEFEAT THE FUNCTION OF THE OPERATOR PRESENCE CONTROLS UNDER ANY CIRCUMSTANCES.

TRAINING:

- Read this operator's manual carefully. Become familiar with the controls and know how to operate your mower properly. Learn how to quickly stop mower.
- Do not allow children to use your mower. Never allow adults to use mower without proper instructions.
- Keep the area of operation clear of all persons, especially small children and pets.
- Use mower only as the manufacturer intended and as described in this manual.
- Do not operate mower if it has been dropped or damaged in any manner. Always have damage repaired before using your mower.
- Do not use accessory attachments that are not recommended by the manufacturer. Use of such attachments may be hazardous.
- The blade turns when the engine is running.

PREPARATION:

- Always thoroughly check the area to be mowed and clear it of all stones, sticks, wires, bones, and other foreign objects. These objects will be thrown by the blade and can cause severe injury.
- Always wear safety glasses or eye shields when starting and while using your mower.
- Dress properly. Do not operate mower when barefoot or wearing open sandals. Wear only solid shoes with good traction when mowing.
- Check fuel tank before starting engine. Do not fill gas tank indoors, when the engine is running or when the engine is hot. Allow the engine to cool for several minutes before filling the gas tank. Clean off any spilled gasoline before starting the engine.
- Always make wheel height adjustments before starting your mower. Never attempt to do this while the engine is running.
- Mow only in daylight or good artificial light.

OPERATION:

- Keep your eyes and mind on your mower and the area being cut. Do not let other interests distract you.
- Do not mow wet or slippery grass. Never run while operating your mower. Always be sure of your footing - keep a firm hold on the handles and walk.
- Do not put hands or feet near or under rotating parts. Keep clear of the discharge opening at all times.
- Always stop the engine whenever you leave or are not using your mower, or before crossing driveways, walks, roads, and any gravel-covered areas.
- Never direct discharge of material toward bystanders nor allow anyone near the mower while you are operating it.
- Before cleaning, inspecting, or repairing your mower, stop the engine and make absolutely sure the blade and all moving parts have stopped. Then disconnect the spark plug wire and keep it away from the spark plug to prevent accidental starting.

- Do not continue to run your mower if you hit a foreign object. Follow the procedure outlined above, then repair any damage before restarting and operating you mower.
- Do not change the governor settings or overspeed the engine. Engine damage or personal injury may result.
- Do not operate your mower if it vibrates abnormally. Excessive vibration is an indication of damage; stop the engine, safely check for the cause of vibration and repair as required.
- Do not run the engine indoors. Exhaust fumes are dangerous.
- Never cut grass by pulling the mower towards you. Mow across the face of slopes, never up and down or you might lose your footing. Do not mow excessively steep slopes. Use caution when operating the mower on uneven terrain or when changing directions - maintain good footing.
- Never operate your mower without proper guards, plates, grass catcher or other safety devices in place.

MAINTENANCE AND STORAGE:

- Check the blade and the engine mounting bolts often to be sure they are tightened properly.
- Check all bolts, nuts and screws at frequent intervals for proper tightness to be sure mower is in safe working condition.
- Keep all safety devices in place and working.
- To reduce fire hazard, keep the engine free of grass, leaves or excessive grease and oil.
- Check grass catcher often for deterioration and wear and replace worn bags. Use only replacement bags that are recommended by and comply with specifications of the manufacturer of your mower.
- Always keep a sharp blade on your mower.
- Allow engine to cool before storing in any enclosure.
- Never store mower with fuel in the tank inside a building where fumes may reach an open flame or an ignition source such as a hot water heater, space heater, clothes dryer, etc.



Look for this symbol to point out important safety precautions. It means CAUTION!!! BECOME ALERT!!! YOUR SAFETY IS INVOLVED.



CAUTION: Always disconnect spark plug wire and place wire where it cannot contact spark plug in order to prevent accidental starting when setting up, transporting, adjusting or making repairs.

WARNING

The engine exhaust from this product contains chemicals known to the State of California to cause cancer, birth defects, or other reproductive harm.

CONGRATULATIONS on your purchase of a Sears Lawn Mower. It has been designed, engineered and manufactured to give you the best possible dependability and performance.

Should you experience any problem you cannot easily remedy, please contact your nearest Sears Authorized Service Center/Department. We have competent, well-trained technicians and the proper tools to service or repair this lawn mower.

Please read and retain this manual. The instructions will enable you to assemble and maintain your lawn mower properly. Always observe the "SAFETY RULES".

MODEL NUMBER	917.377210
SERIAL NUMBER	_____
DATE OF PURCHASE	_____
THE MODEL AND SERIAL NUMBERS WILL BE FOUND ON A DECAL ATTACHED TO THE REAR OF THE LAWN MOWER HOUSING	
YOU SHOULD RECORD BOTH SERIAL NUMBER AND DATE OF PURCHASE AND KEEP IN A SAFE PLACE FOR FUTURE REFERENCE.	

PRODUCT SPECIFICATIONS

HORSEPOWER:	6.25
DISPLACEMENT:	12.56 CU. IN.
GASOLINE CAPACITY AND TYPE:	1.6 QUARTS UNLEADED REGULAR
OIL TYPE (API-SF/SG):	SAE 30 (ABOVE 32°F) SAE 5W-30 (BELOW 32°F)
OIL CAPACITY:	20 OZS.
SPARK PLUG: (GAP: .030")	CHAMPION J19LM, RJ19LM STD361458
VALVE CLEARANCE:	INTAKE: .005-.007 EXHAUST: .007-.009
SOLID STATE IGNITION AIR GAP:	.0125 IN.
BLADE BOLT TORQUE:	35-40 FT. LBS.

MAINTENANCE AGREEMENT

A Sears Maintenance Agreement is available on this product. Contact your nearest Sears store for details.

CUSTOMER RESPONSIBILITIES

- Read and observe the safety rules.
- Follow a regular schedule in maintaining, caring for and using your lawn mower.
- Follow the instructions under "Customer Responsibilities" and "Storage" sections of this owner's manual.

LIMITED TWO YEAR WARRANTY ON CRAFTSMAN POWER MOWER

For two (2) years from date of purchase, when this Craftsman Lawn Mower is maintained, lubricated, and tuned up according to the operating and maintenance instructions in the owner's manual, Sears will repair free of charge any defect in material or workmanship.

If this Craftsman Lawn Mower is used for commercial or rental purposes, this warranty applies for only 90 days from the date of purchase.

This Warranty does not cover:

- Expendable items which become worn during normal use, such as rotary mower blades, blade adapters, belts, air cleaners and spark plug.
- Repairs necessary because of operator abuse or negligence, including bent crankshafts and the failure to maintain the equipment according to the instructions contained in the owner's manual.

WARRANTY SERVICE IS AVAILABLE BY RETURNING THE CRAFTSMAN POWER MOWER TO THE NEAREST SEARS SERVICE CENTER/DEPARTMENT IN THE UNITED STATES. THIS WARRANTY APPLIES ONLY WHILE THIS PRODUCT IS IN USE IN THE UNITED STATES.

This Warranty gives you specific legal rights, and you may also have other rights which vary from state to state.

SEARS, ROEBUCK AND CO., D/817 WA, HOFFMAN ESTATES, ILLINOIS 60179

TABLE OF CONTENTS

SAFETY RULES	2	SERVICE AND ADJUSTMENTS	12
PRODUCT SPECIFICATIONS	3	STORAGE	14
CUSTOMER RESPONSIBILITIES	3, 9-11	REPAIR PARTS - LAWN MOWER	15-19
WARRANTY	3	REPAIR PARTS - ENGINE	20-22
ASSEMBLY	5	TROUBLESHOOTING	23
OPERATION	6	PARTS ORDERING/SERVICE	26
MAINTENANCE SCHEDULE	9		





INDEX

<p>A</p> <p>Accessories 5</p> <p>Adjustments:</p> <p style="padding-left: 20px;">Carburetor 13</p> <p style="padding-left: 20px;">Drive Belt 12</p> <p style="padding-left: 20px;">Engine Speed 13</p> <p style="padding-left: 20px;">Handle Height 13</p> <p style="padding-left: 20px;">Height of Cut 7</p> <p>Air Filter:</p> <p style="padding-left: 20px;">Replacement 11</p> <p style="padding-left: 20px;">Service 11</p> <p>Assembly 5</p> <p>B</p> <p>Blade:</p> <p style="padding-left: 20px;">Sharpening 10</p> <p style="padding-left: 20px;">Replacement 10</p> <p>C</p> <p>Controls:</p> <p style="padding-left: 20px;">Drive Control 6</p> <p style="padding-left: 20px;">Engine Zone Control 6</p> <p style="padding-left: 20px;">Engine Speed Control 6</p> <p style="padding-left: 20px;">Operator Presence Control Bar 6</p> <p>Customer Responsibilities 3, 9-11</p> <p style="padding-left: 20px;">Air Filter 11</p> <p style="padding-left: 20px;">Blade Care/Replacement 10</p> <p style="padding-left: 20px;">Drive Wheels 10</p> <p style="padding-left: 20px;">Engine 11</p> <p style="padding-left: 20px;">Lubrication 9</p> <p style="padding-left: 20px;">Spark Plug 11</p> <p>Cutting Levels 7</p>	<p>E</p> <p>Engine:</p> <p style="padding-left: 20px;">Air Filter 11</p> <p style="padding-left: 20px;">Oil Change 11</p> <p style="padding-left: 20px;">Oil Level 11</p> <p style="padding-left: 20px;">Oil Type 11</p> <p style="padding-left: 20px;">Starting 8</p> <p style="padding-left: 20px;">Stopping 8</p> <p style="padding-left: 20px;">Storage 14</p> <p>F</p> <p>Fuel:</p> <p style="padding-left: 20px;">Capacity 3</p> <p style="padding-left: 20px;">Storage 14</p> <p style="padding-left: 20px;">Type 8</p> <p>H</p> <p>Handle Adjustment:</p> <p style="padding-left: 20px;">Assembly 5</p> <p style="padding-left: 20px;">Cutting Height 13</p> <p>L</p> <p>Lubrication:</p> <p style="padding-left: 20px;">Engine 11</p> <p style="padding-left: 20px;">Lawn Mower 9</p> <p>M</p> <p>Maintenance Agreement 3</p> <p>Maintenance Schedule 9</p> <p>Mowing Tips 8</p> <p>O</p> <p>Oil:</p> <p style="padding-left: 20px;">Engine 11</p> <p style="padding-left: 20px;">Storage 14</p>	<p>Operation:</p> <p style="padding-left: 20px;">Drive Control 7</p> <p style="padding-left: 20px;">Engine Control 7</p> <p style="padding-left: 20px;">Grass Catcher 7</p> <p style="padding-left: 20px;">Mower 7</p> <p style="padding-left: 20px;">Operator Presence Control Bar 7</p> <p>Options:</p> <p style="padding-left: 20px;">Accessories 5</p> <p>R</p> <p>Repair Parts:</p> <p style="padding-left: 20px;">Engine 20-22</p> <p style="padding-left: 20px;">Lawn Mower 15-19</p> <p>Responsibilities, Customer 3, 9-11</p> <p>S</p> <p>Safety Rules 2</p> <p>Service and Adjustments 12</p> <p style="padding-left: 20px;">Carburetor 13</p> <p style="padding-left: 20px;">Drive Belt 12</p> <p style="padding-left: 20px;">Engine Speed 13</p> <p style="padding-left: 20px;">Handle 13</p> <p>Spark Plug 11</p> <p>Specifications 3</p> <p>Speed Control:</p> <p style="padding-left: 20px;">Engine 7</p> <p>Starting the Engine 8</p> <p>Stopping the Engine 8</p> <p>Storage 14</p> <p>T</p> <p>Trouble Shooting Chart 23</p> <p>W</p> <p>Warranty 3</p>
---	---	---





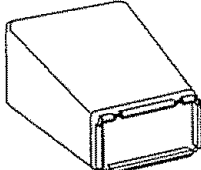
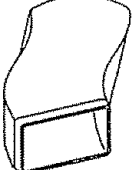

LAWN MOWER ACCESSORIES

These accessories were available when this lawn mower was produced. They are also available at most Sears retail outlets and service centers. Most Sears stores can also order repair parts for you, when you provide the model number of your lawn mower. Some of these accessories may not apply to your lawn mower.

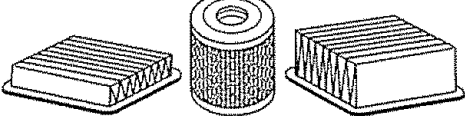
LAWN MOWER PERFORMANCE

 <p>CLIPPING DEFLECTOR FOR REAR DISCHARGE LAWN MOWERS</p>	 <p>MULCHER KITS</p>	 <p>STABILIZER</p>
 <p>GRASS CATCHERS FOR REAR DISCHARGE LAWN MOWERS</p>	 <p>GRASS CATCHERS FOR SIDE DISCHARGE LAWN MOWERS</p>	 <p>GAS CANS</p>

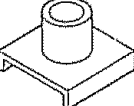
LAWN MOWER MAINTENANCE

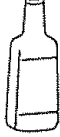
 <p>MUFFLERS</p>		 <p>AIR FILTERS</p>		 <p>SPARK PLUGS</p>
 <p>BELTS</p>	 <p>BLADES</p>	 <p>BLADE ADAPTERS</p>	 <p>WHEELS</p>	 <p>ENGINE OIL</p>

ASSEMBLY

Read these instructions and this manual in its entirety before you attempt to assemble or operate your new lawn mower. Your new lawn mower has been assembled at the factory with the exception of those parts left unassembled for shipping purposes. All parts such as nuts, washers, bolts, etc., necessary to complete the assembly have been placed in the parts bag. To ensure safe and proper operation of your lawn mower, all parts and hardware you assemble must be tightened securely. Use the correct tools as necessary to ensure proper tightness.

TO REMOVE LAWN MOWER FROM CARTON

- Remove loose parts included with mower.
- Cut down two end corners of carton and lay end panel down flat.
- Remove all packing materials except padding between upper and lower handle and padding holding operator presence control bar to upper handle.
- Roll lawn mower out of carton and check carton thoroughly for additional loose parts.

HOW TO SET UP YOUR LAWN MOWER

TO UNFOLD HANDLE (See Fig. 1)

IMPORTANT: UNFOLD HANDLE CAREFULLY SO AS NOT TO PINCH OR DAMAGE CONTROL CABLES.

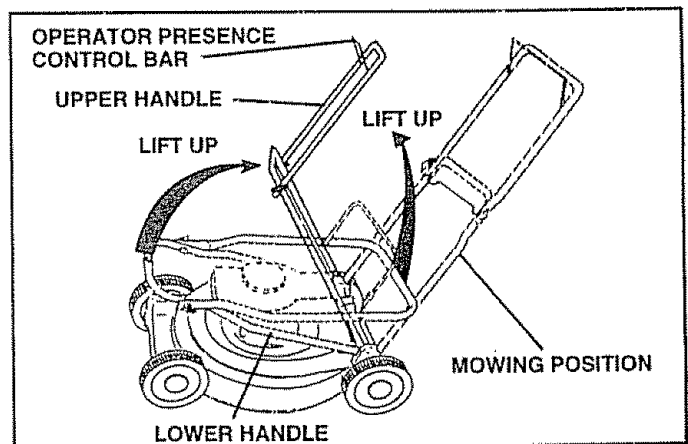

FIG. 1

- Raise handles until lower handle section locks into place in mowing position.
- Raise upper handle section into place on lower handle, remove protective padding and tighten both handle knobs.
- Remove handle padding holding operator presence control bar to upper handle.
- Your lawn mower handle can be adjusted for your mowing comfort. Refer to "Adjust Handle" in the Service and Adjustment section of this manual.

OPERATION

KNOW YOUR LAWN MOWER

READ THIS OWNER'S MANUAL AND SAFETY RULES BEFORE OPERATING YOUR LAWN MOWER. Compare the illustrations with your lawn mower to familiarize yourself with the location of various controls and adjustments. Save this manual for future reference.

These symbols may appear on your lawn mower or in literature supplied with the product. Learn and understand their meaning.

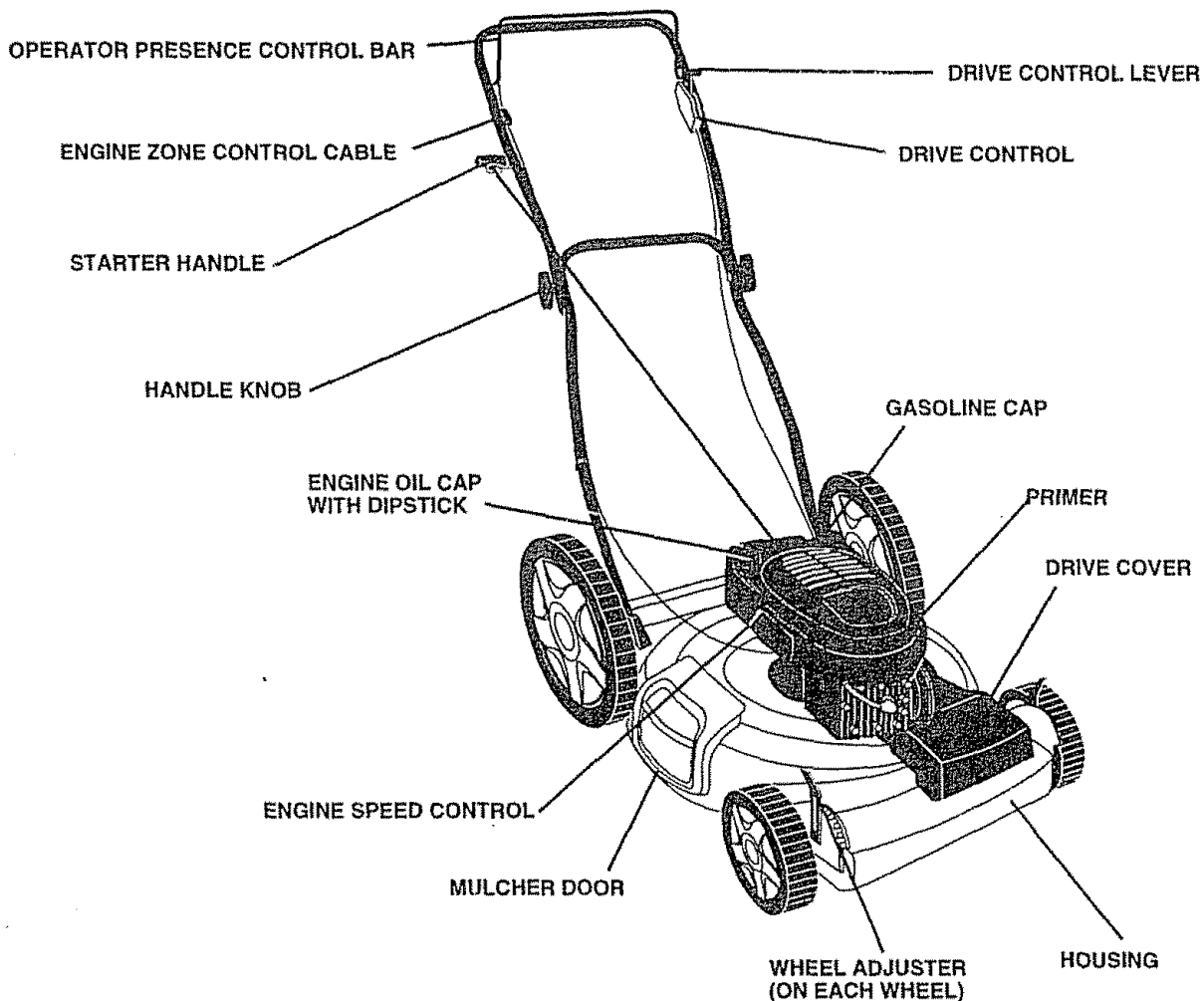
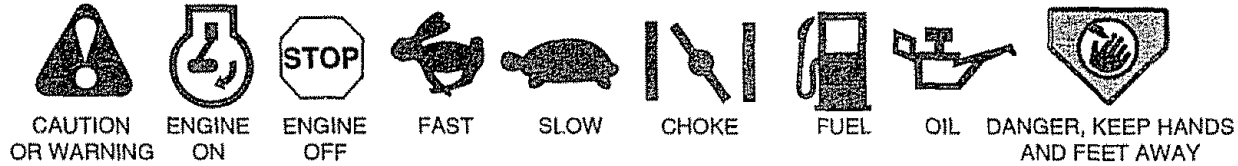

MEETS CPSC SAFETY REQUIREMENTS

Sears rotary walk-behind power lawn mowers conform to the safety standards of the American National Standards Institute and the U.S. Consumer Product Safety Commission. The blade turns when the engine is running.

OPERATOR PRESENCE CONTROL - must be held down to the handle to start the engine. Release to stop the engine.

PRIMER - pumps additional fuel from the carburetor to the cylinder for use when starting a cold engine.

STARTER HANDLE - used for starting the engine.

DRIVE CONTROL LEVER - used to engage power-propelled forward motion of lawn mower.

MULCHER DOOR - allows conversion to discharge or bagging operation.

ENGINE SPEED CONTROL LEVER - must be in the fast (⚡) position for starting and mowing.

OPERATION



The operation of any lawn mower can result in foreign objects thrown into the eyes, which can result in severe eye damage. Always wear safety glasses or eye shields while operating your lawn mower or performing any adjustments or repairs. We recommend a wide vision safety mask over the spectacles or standard safety glasses.

HOW TO USE YOUR LAWN MOWER ENGINE SPEED CONTROL (See Fig. 2)

The engine speed is controlled by a lever located on the side of the engine. Fast (👉) position is for starting the engine, normal cutting and better grass bagging. Slow (👈) position is for light cutting, trimming and fuel economy.

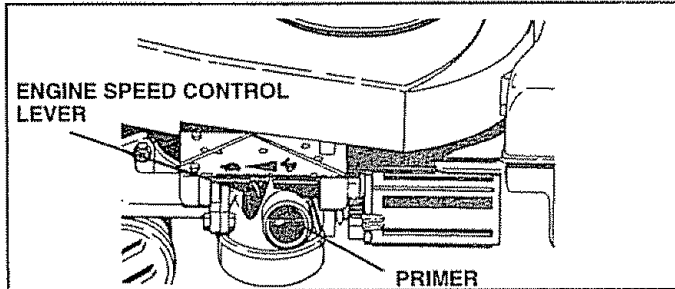

FIG. 2

ENGINE ZONE CONTROL



CAUTION: Federal regulations require an engine control to be installed on this lawn mower in order to minimize the risk of blade contact injury. Do not under any circumstances attempt to defeat the function of the operator control. The blade turns when the engine is running.

- Your lawn mower is equipped with an operator presence control bar which requires the operator to be positioned behind the lawn mower handle to start and operate the lawn mower.

DRIVE CONTROL (See Fig. 3)

- Self-propelling is controlled by holding the operator presence control bar down to the handle and pushing the drive control lever forward until it clicks; then release the lever.
- Forward motion will stop when the operator presence control bar is released. To stop forward motion without stopping engine, release the operator presence control bar slightly until the drive control disengages. Hold operator presence control bar down to handle to continue mowing without self-propelling.
- To keep drive control engaged when turning corners, push down on handle and lift front wheels off ground while turning lawn mower.

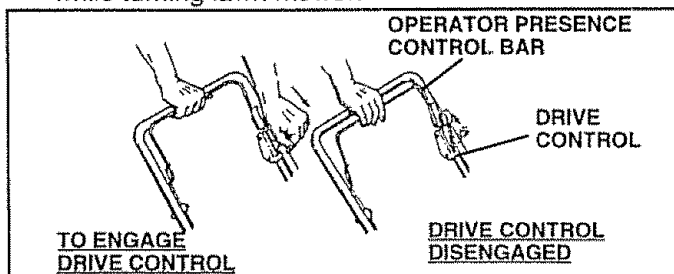

FIG. 3

TO ADJUST CUTTING HEIGHT (See Fig. 4)

- Raise wheels for low cut and lower wheels for high cut.
- Adjust cutting height to suit your requirements. Medium position is best for most lawns.
- To change cutting height, squeeze adjuster lever toward wheel. Move wheel up or down to suit your requirements. Be sure all wheels are in the same setting.

NOTE: Adjuster is properly positioned when plate tab inserts into hole in lever. Also, 9-position adjusters (if so equipped) allow lever to be positioned between the plate tabs.

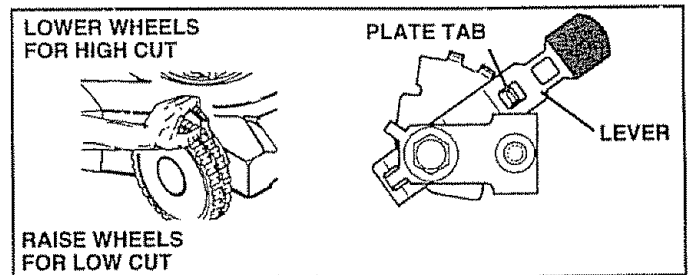

FIG. 4

NOTE: Your lawn mower has been shipped ready for mulching operation. To convert to discharging operation, you must install the discharge deflector attachment included with your mower.

TO INSTALL DISCHARGING DEFLECTOR (See Fig. 5)

- Lift door upward on its hinge until the deflector frame can be hooked over the door mounting bracket as shown.
- Release the door to rest against deflector frame.
- To return to mulching operation, reverse the above steps and be sure door is in closed position.

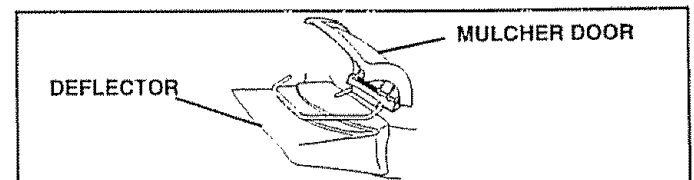

FIG. 5



CAUTION: Do not operate your lawn mower without mulcher door in closed position, discharge deflector in place, or approved grass catcher in place.

BEFORE STARTING ENGINE OIL (See Fig. 6)

Your lawn mower is shipped without oil in the engine.

- Be sure mower is level and area around oil fill is clean.
- Remove engine oil cap w/dipstick and fill to the full line on the dipstick.
- Use 20 ozs. of oil. For type and grade of oil to use, see "ENGINE" in Customer Responsibilities section of this manual.

OPERATION

- Pour oil slowly. Do not over fill.
- Check oil level before each use. Add oil if needed. Fill to full line on dipstick.
- To read proper level, tighten engine oil cap each time.
- Reinstall engine oil cap and tighten.
- After the first two (2) hours of mowing, change the oil, and every 25 hours thereafter. You may need to change the oil more often under dusty, dirty conditions.

GAS (See Fig. 6)

- Fill gasoline tank with fresh, clean, unleaded gasoline. **DO NOT USE PREMIUM GASOLINE. BE CAREFUL NOT TO OVER FILL TANK.**

WARNING: Experience indicates that alcohol blended fuels (called gasohol or using ethanol or methanol) can attract moisture which leads to separation and formation of acids during storage. Acidic gas can damage the fuel system of an engine while in storage. To avoid engine problems, the fuel system should be emptied before storage of 30 days or longer. Drain the fuel tank, start the engine and let it run until fuel lines and carburetor are empty. Use fresh fuel next season. See Storage Instructions for additional information. Never use engine or carburetor cleaner products in fuel tank or permanent damage may occur.

TO START ENGINE

- To start a cold engine, push primer five (5) times before trying to start. Use a firm push. This step is not usually necessary when starting an engine which has already run for a few minutes.
- Hold operator presence control bar down to the handle and pull starter handle quickly. **DO NOT** allow starter rope to snap back.
- To **STOP** engine, release operator presence control bar.

NOTE: In cooler weather it may be necessary to repeat priming steps. In warmer weather over priming may cause flooding and engine will not start. If you do flood engine, wait a few minutes before attempting to start and **DO NOT** repeat priming steps.

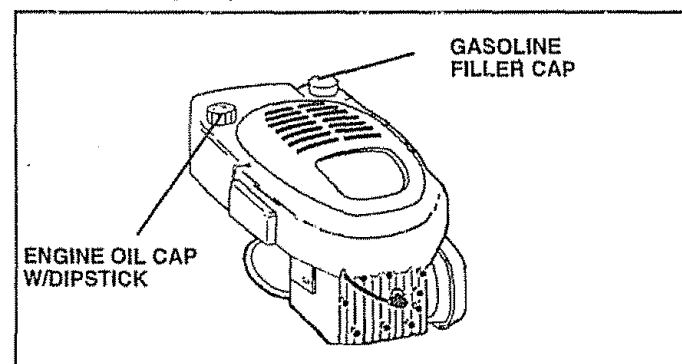

FIG. 6

MOWING TIPS

- Under certain conditions, such as very tall grass, it may be necessary to raise the height of cut to reduce pushing effort and to keep from overloading the engine and leaving clumps of grass clippings.

- For extremely heavy cutting, reduce the width of cut by overlapping previously cut path and mow slowly.
- For better grass bagging and most cutting conditions, the engine speed should be set in the fast (⚡) position.
- For side discharge lawn mowers, cutting in a counter-clockwise direction, starting at the outside of the area to be cut, spreads grass clippings more evenly and puts less load on the engine. To keep clippings off of walkways, flower beds, etc., make the first cuts in a clockwise direction.
- Pores in cloth grass catchers can become filled with dirt and dust with use and catchers will collect less grass. To prevent this, regularly hose catcher off with water and let dry before using.
- Keep top of engine around starter clear and clean of grass clippings and chaff. This will help engine air flow and extend engine life.

MULCHING MOWING TIPS

IMPORTANT: FOR BEST PERFORMANCE, KEEP MOWER HOUSING FREE OF BUILT-UP GRASS AND TRASH. SEE "CLEANING" IN CUSTOMER RESPONSIBILITIES SECTION OF THIS MANUAL.

- The special mulching blade will recut the grass clippings many times and reduce them in size so that as they fall onto the lawn they will disperse into the grass and not be noticed. Also, the mulched grass will biodegrade quickly to provide nutrients for the lawn. Always mulch with your highest engine (blade) speed as this will provide the best recutting action of the blades.
- Avoid cutting your lawn when it is wet. Wet grass tends to form clumps and interferes with the mulching action. The best time to mow your lawn is the early afternoon. At this time the grass has dried and the newly cut area will not be exposed to the direct sun.
- For best results, adjust the lawn mower cutting height so that the lawn mower cuts off only the top one-third of the grass blades (See Fig. 7). If the lawn is overgrown it will be necessary to raise the height of cut to reduce pushing effort and to keep from overloading the engine and leaving clumps of mulched grass. For extremely heavy mulching, reduce your width of cut by overlapping previously cut path and mow slowly.
- Certain types of grass and grass conditions may require that an area be mulched a second time to completely hide the clippings. When doing a second cut, mow across or perpendicular to the first cut path.
- Change your cutting pattern from week to week. Mow north to south one week then change to east to west the next week. This will help prevent matting and graining of the lawn.

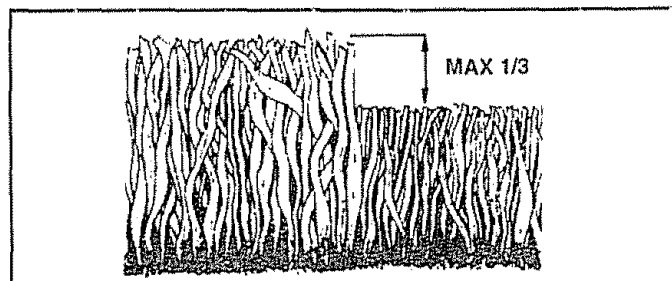

FIG. 7

CUSTOMER RESPONSIBILITIES

LAWN MOWER

Always observe safety rules when performing any maintenance.

TIRES

- Keep tires free of gasoline, oil, or insect control chemicals which can harm rubber.
- Avoid stumps, stones, deep ruts, sharp objects and other hazards that may cause tire damage.

BLADE CARE

For best results, mower blade must be kept sharp. Replace bent or damaged blades.

TO REMOVE BLADE (See Fig. 8)

- Disconnect spark plug wire from spark plug and place wire where it cannot come in contact with spark plug.
- Turn lawn mower on its side. Make sure air filter and carburetor are up.
- Use a wood block between blade and mower housing to prevent blade from turning when removing blade bolt.
- Protect your hands with gloves and/or wrap blade with heavy cloth.
- Remove blade bolt by turning counter-clockwise. Use a 9/16" box or open-end wrench.
- Remove blade and attaching hardware (bolt, lock washer and hardened washer).

NOTE: Remove the blade adapter and check the key inside hub of blade adapter. The key must be in good condition to work properly. Replace adapter if damaged.

TO REPLACE BLADE (See Fig. 8)

- Position the blade adapter on the engine crankshaft. Be sure key in adapter and crankshaft keyway are aligned.
- Position blade on the blade adapter aligning the two (2) holes in the blade with the raised lugs on the adapter.
- Be sure the trailing edge of blade (opposite sharp edge) is up toward the engine.
- Install the blade bolt with the lock washer and hardened washer into blade adapter and crankshaft.
- Use block of wood between blade and lawn mower housing and tighten the blade bolt, turning clockwise.
- The recommended tightening torque is 35-40 ft. lbs.

IMPORTANT: BLADE BOLT IS GRADE 8 HEAT TREATED.

NOTE: We do not recommend sharpening blade - but if you do, be sure the blade is balanced.

TO SHARPEN BLADE

Care should be taken to keep the blade balanced. An unbalanced blade will cause eventual damage to lawn mower or engine.

- The blade can be sharpened with a file or on a grinding wheel. Do not attempt to sharpen while on the mower.
- To check blade balance, drive a nail into a beam or wall. Leave about one inch of the straight nail exposed. Place center hole of blade over the head of the nail. If blade is balanced, it should remain in a horizontal position. If either end of the blade moves downward, sharpen the heavy end until the blade is balanced.

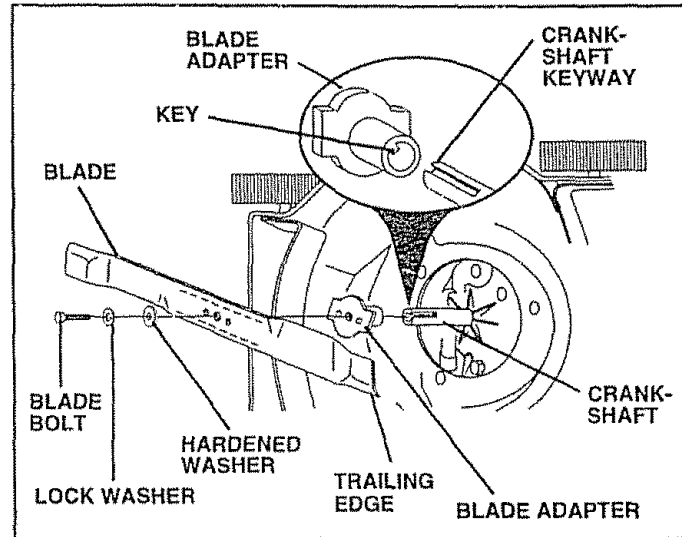

FIG. 8

GEAR CASE

- To keep your drive system working properly, the gear case and area around the drive should be kept clean and free of trash build-up. Clean under the drive cover twice a season.
- The gear case is filled with lubricant to the proper level at the factory. The only time the lubricant needs attention is if service has been performed on the gear case.
- If lubricant is required, use only Texaco Starplex Premium Grease, part no. 750355. Do not substitute.

DRIVE WHEELS

Check front drive wheels each time before you mow to be sure they move freely.

The wheels not turning freely means trash, grass cuttings, etc. are in the drive wheel area and must be cleaned to free drive wheels.

If necessary to clean the drive wheels, check both front wheels.

- Remove hubcaps, hairpin cotters and washers.
- Remove wheels from wheel adjusters.
- Remove any trash or grass cuttings from inside the dust cover, pinion and/or drive wheel gear teeth.
- Put wheels back in place.
- If after cleaning, the drive wheels do not turn freely, contact your nearest authorized service center.

GRASS CATCHER

(If purchased as an accessory)

- The grass catcher may be hosed with water, but must be dry when used.
- Check your grass catcher often for damage or deterioration. Through normal use it will wear. If catcher needs replacing, replace only with a manufacturer approved replacement catcher. Give the lawn mower model number when ordering.

CUSTOMER RESPONSIBILITIES

ENGINE LUBRICATION

Use only high quality detergent oil rated with API service classification SF or SG. Select the oil's SAE viscosity grade according to your expected operating temperature.

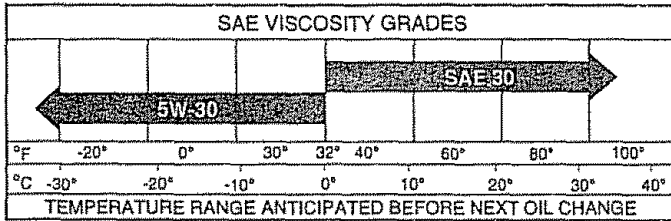

NOTE: Although multi-viscosity oils (5W30, 10W30 etc.) improve starting in cold weather, these multi-viscosity oils will result in increased oil consumption when used above 32°F. Check your engine oil level more frequently to avoid possible engine damage from running low on oil.

Change the oil after the first two hours of operation and every 25 hours thereafter or at least once a year if the lawn mower is not used for 25 hours in one year.

Check the crankcase oil level before starting the engine and after each five (5) hours of continuous use. Tighten oil plug securely each time you check the oil level.

TO CHANGE ENGINE OIL (See Fig. 9)

NOTE: Before tipping lawn mower to drain oil, drain fuel tank by running engine until fuel tank is empty.

- Disconnect spark plug wire from spark plug and place wire where it cannot come in contact with spark plug.
- Remove engine oil cap; lay aside on a clean surface.
- Tip lawn mower on its side and drain oil into a suitable container. Rock lawn mower back and forth to remove any oil trapped inside of engine.
- Wipe off any spilled oil on lawn mower and on side of engine.
- Fill engine with oil. Fill only to the "FULL" line on the dipstick. DO NOT OVER FILL.
- Replace engine oil cap.
- Reconnect spark plug wire to spark plug.

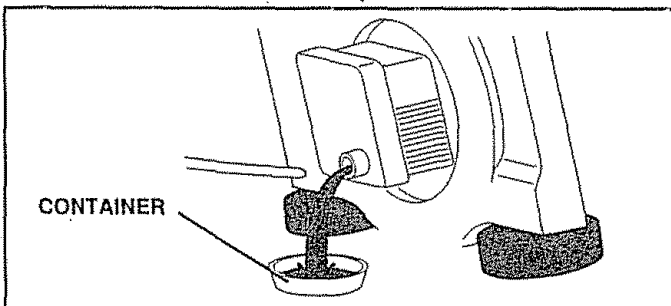

FIG. 9

AIR FILTER

Your engine will not run properly and may be damaged by using a dirty air filter.

Replace the air filter every year, more often if you mow in very dusty, dirty conditions.

TO CLEAN AIR FILTER (See Fig. 10)

- Remove the air filter by turning counterclockwise to the stop and pull away from collar.
- Remove filter from inside of cover.
- Clean the inside of the cover and the collar to remove any dirt accumulation.

- Insert new filter into cover.
- Put air filter cover and filter into collar aligning the tab with the slot.
- Push in on cover and turn clockwise to tighten.



CAUTION: Petroleum solvents, such as kerosene, are not to be used to clean cartridge. They may cause deterioration of the cartridge. Do not oil cartridge. Do not use pressurized air to clean or dry cartridge.

- Install cartridge, then replace cover making sure the tabs are aligned with the slots in the back plate. Fasten screw securely.

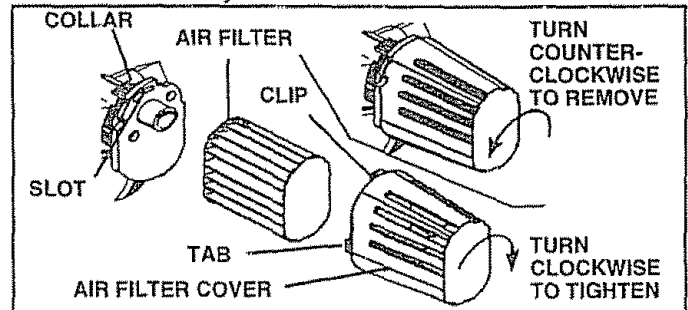

FIG. 10

MUFFLER

Inspect and replace corroded muffler as it could create a fire hazard and/or damage.

SPARK PLUG

Change your spark plug each year to make your engine start easier and run better. Set spark plug gap at .030 inch.

CLEANING

IMPORTANT: FOR BEST PERFORMANCE, KEEP MOWER HOUSING FREE OF BUILT-UP GRASS AND TRASH. CLEAN THE UNDERSIDE OF YOUR MOWER AFTER EACH USE.



CAUTION: Disconnect spark plug wire from spark plug and place wire where it cannot come in contact with the spark plug.

- Turn lawn mower on its side. Make sure air filter and carburetor are up. Clean the underside of your lawn mower by scraping to remove build-up of grass and trash.
- Clean engine often to keep trash from accumulating. A clogged engine runs hotter and shortens engine life.
- Keep finished surfaces and wheels free of all gasoline, oil, etc.
- We do not recommend using a garden hose to clean lawn mower unless the electrical system, muffler, air filter and carburetor are covered to keep water out. Water in engine can result in shortened engine life.

CLEAN UNDER DRIVE COVER

Clean under drive cover at least twice a season. Scrape underside of cover with putty knife or similar tool to remove any build-up of trash or grass on underside of drive cover.

SERVICE AND ADJUSTMENTS



CAUTION: BEFORE PERFORMING ANY SERVICE OR ADJUSTMENTS:

- Release control bar.
- Make sure the blade and all moving parts have completely stopped.
- Disconnect spark plug wire from spark plug and place where it cannot come in contact with plug.

LAWN MOWER

TO ADJUST CUTTING HEIGHT

See "TO ADJUST CUTTING HEIGHT" in the Operation section of this manual.

DISCHARGE GUARD

The discharge guard, attached to the discharge opening of your lawn mower, is provided to prevent the possibility of injury resulting from objects being thrown out of the discharge opening into the operator mowing position. If the discharge guard becomes damaged, it should be replaced.

REAR DEFLECTOR

The rear deflector, attached between the rear wheels of your mower, is provided to minimize the possibility that objects will be thrown out of the rear of the mower into the operator mowing position. If the deflector becomes damaged, it should be replaced.

TO REMOVE/REPLACE DRIVE BELT

(See Fig. 11)

- Remove drive cover. Remove belt by pushing down on gear case pulley.
- Turn lawn mower on its side with carburetor and fuel cap up.
- Remove blade.
- Remove debris shield.
- Remove belt from engine pulley on crankshaft.
- Install new belt by reversing above steps.
- Always use factory approved belt to assure fit and long life.

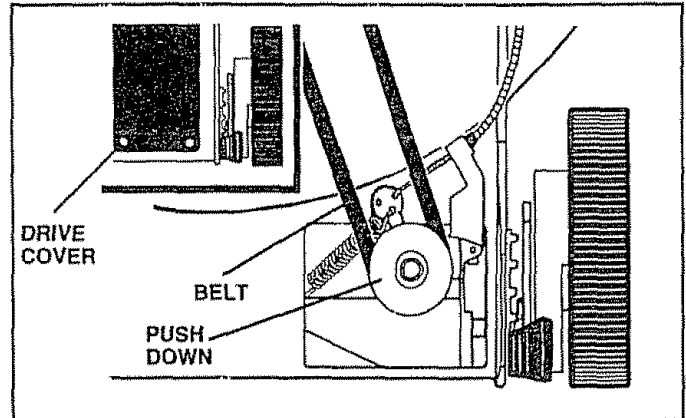

FIG. 11

SERVICE AND ADJUSTMENTS

TO ADJUST HANDLE (See Figs. 12 Thru 14)

Your lawn mower handle can be raised or lowered for your mowing comfort. Four (4) positions are available: high, medium high, medium low and low. Handles are shipped mounted in the medium low position.

- To change from medium low to medium high position, the upper and lower handle sections will have to be turned over (See Fig. 12B).
- Remove the controls and operator presence control bar from the upper handle.
- Remove the starter rope guide from the lower handle.
- Remove hairpin cotters.
- Disconnect the lower handle from the handle brackets (See Fig. 14).
- Turn the handle over and reassemble the hairpin cotters that have been removed.
- Reassemble the starter rope guide.
- Reassemble the controls and the operator presence control bar to the upper handle.

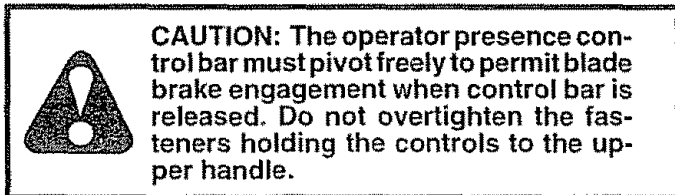

- To change from medium low to high position only the upper handle section will have to be turned over (See Fig. 13A).
- To change from medium low to low position, only the lower handle section will have to be turned over (See Fig. 13B).

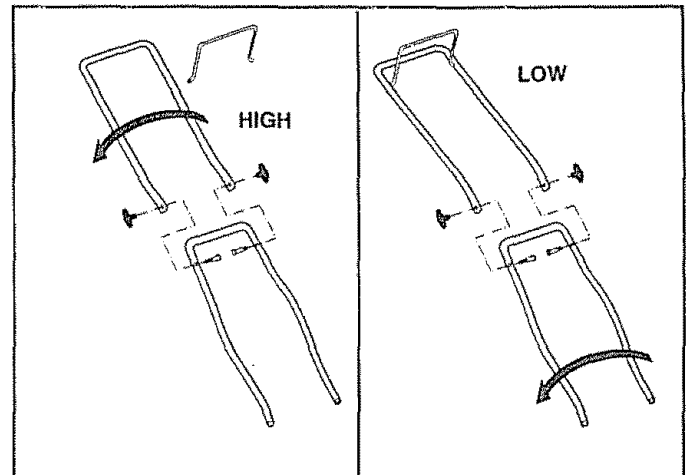
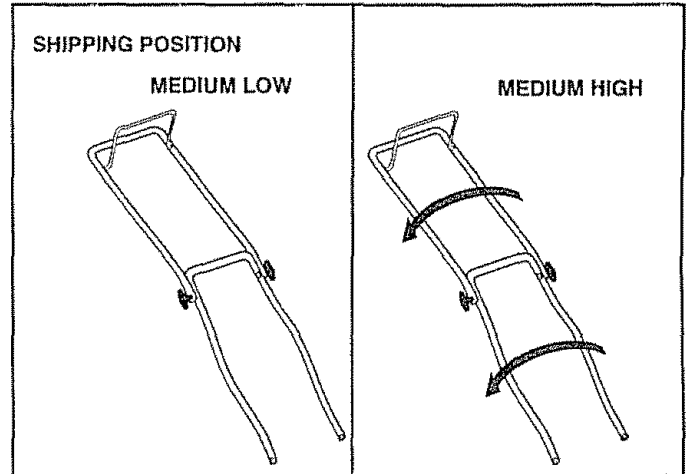

ENGINE

ENGINE SPEED

Your engine speed has been factory set. Do not attempt to increase engine speed or it may result in personal injury. If you believe that engine is running too fast or too slow, take your mower to an authorized service center for repair and adjustment.

CARBURETOR

Your carburetor is not adjustable. If your engine does not operate properly due to suspected carburetor problems, take your lawn mower to an authorized service center for repair and/or adjustment.

IMPORTANT: NEVER TAMPER WITH THE ENGINE GOVERNOR, WHICH IS FACTORY SET FOR PROPER ENGINE SPEED. OVERSPEEDING THE ENGINE ABOVE THE FACTORY HIGH SPEED SETTING CAN BE DANGEROUS. IF YOU THINK THE ENGINE-GOVERNED HIGH SPEED NEEDS ADJUSTING, CONTACT YOUR NEAREST AUTHORIZED SERVICE CENTER, WHICH HAS PROPER EQUIPMENT AND EXPERIENCE TO MAKE ANY NECESSARY ADJUSTMENTS.

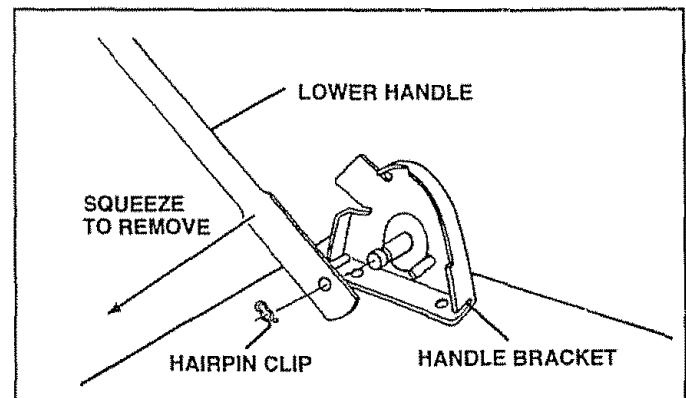

STORAGE

Immediately prepare your lawn mower for storage at the end of the season or if the unit will not be used for 30 days or more.

LAWN MOWER

When lawn mower is to be stored for a period of time, clean it thoroughly, remove all dirt, grease, leaves, etc. Store in a clean, dry area.

- Clean entire lawn mower (See "CLEANING" in the Customer Responsibilities section of this manual).
- Lubricate as shown in the Customer Responsibilities section of this manual.
- Be sure that all nuts, bolts, screws, and pins are securely fastened. Inspect moving parts for damage, breakage and wear. Replace if necessary.
- Touch up all rusted or chipped paint surfaces; sand lightly before painting.

HANDLE (See Fig. 15)

You can fold your lawn mower handle for storage.

- Squeeze the bottom ends of the lower handle toward each other until the lower handle clears the handle bracket, then move handle forward.
- Loosen upper handle mounting bolts enough to allow upper handle to be folded back.

IMPORTANT: WHEN FOLDING THE HANDLE FOR STORAGE OR TRANSPORTATION, BE SURE TO FOLD THE HANDLE AS SHOWN OR YOU MAY DAMAGE THE CONTROL CABLES.

- When setting up your handle from the storage position, the lower handle will automatically lock into the mowing position.

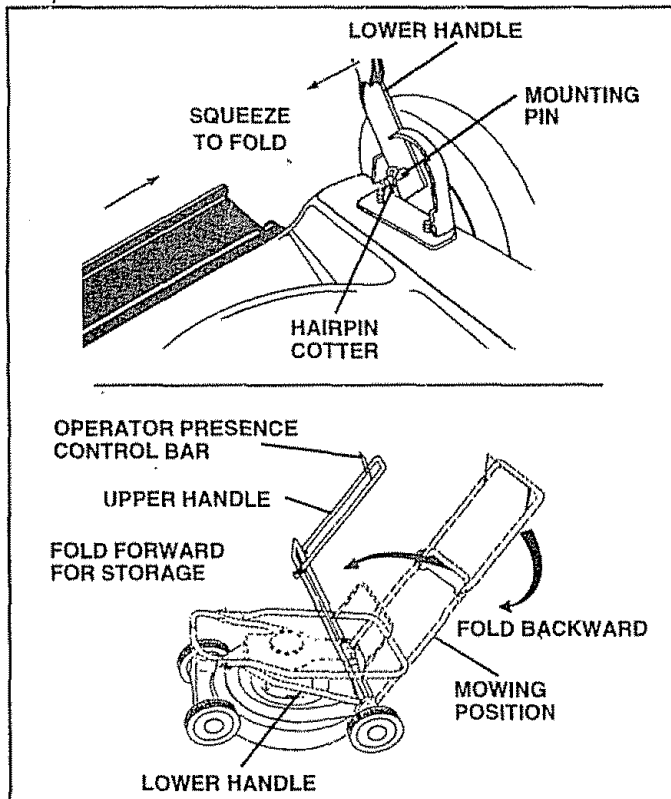

FIG. 15

ENGINE

FUEL SYSTEM

IMPORTANT: IT IS IMPORTANT TO PREVENT GUM DEPOSITS FROM FORMING IN ESSENTIAL FUEL SYSTEM PARTS SUCH AS CARBURETOR, FUEL FILTER, FUEL HOSE, OR TANK DURING STORAGE. ALSO, EXPERIENCE INDICATES THAT ALCOHOL BLENDED FUELS (CALLED GASOHOL OR USING ETHANOL OR METHANOL) CAN ATTRACT MOISTURE WHICH LEADS TO SEPARATION AND FORMATION OF ACIDS DURING STORAGE. ACIDIC GAS CAN DAMAGE THE FUEL SYSTEM OF AN ENGINE WHILE IN STORAGE.

- Drain the fuel tank.
- Start the engine and let it run until the fuel lines and carburetor are empty.
- Never use engine or carburetor cleaner products in the fuel tank or permanent damage may occur.
- Use fresh fuel next season.

NOTE: Fuel stabilizer is an acceptable alternative in minimizing the formation of fuel gum deposits during storage. Add stabilizer to gasoline in fuel tank or storage container. Always follow the mix ratio found on stabilizer container. Run engine at least 10 minutes after adding stabilizer to allow the stabilizer to reach the carburetor. Do not drain the gas tank and carburetor if using fuel stabilizer.

ENGINE OIL

Drain oil (with engine warm) and replace with clean engine oil. (See "ENGINE" in the Customer Responsibilities section of this manual).

CYLINDER

- Remove spark plug.
- Pour one ounce (29 ml) of oil through spark plug hole into cylinder.
- Pull starter handle slowly a few times to distribute oil.
- Replace with new spark plug.

OTHER

- Do not store gasoline from one season to another.
- Replace your gasoline can if your can starts to rust. Rust and/or dirt in your gasoline will cause problems.
- If possible, store your unit indoors and cover it to give protection from dust and dirt.
- Cover your unit with a suitable protective cover that does not retain moisture. Do not use plastic. Plastic cannot breathe which allows condensation to form and will cause your unit to rust.

IMPORTANT: NEVER COVER MOWER WHILE ENGINE AND EXHAUST ARE STILL WARM.



CAUTION: Never store the lawn mower with gasoline in the tank inside a building where fumes may reach an open flame or spark. Allow the engine to cool before storing in any enclosure.

REPAIR PARTS

ROTARY LAWN MOWER -- MODEL NO. 917.377210

GEAR CASE ASSEMBLY PART NUMBER 702511

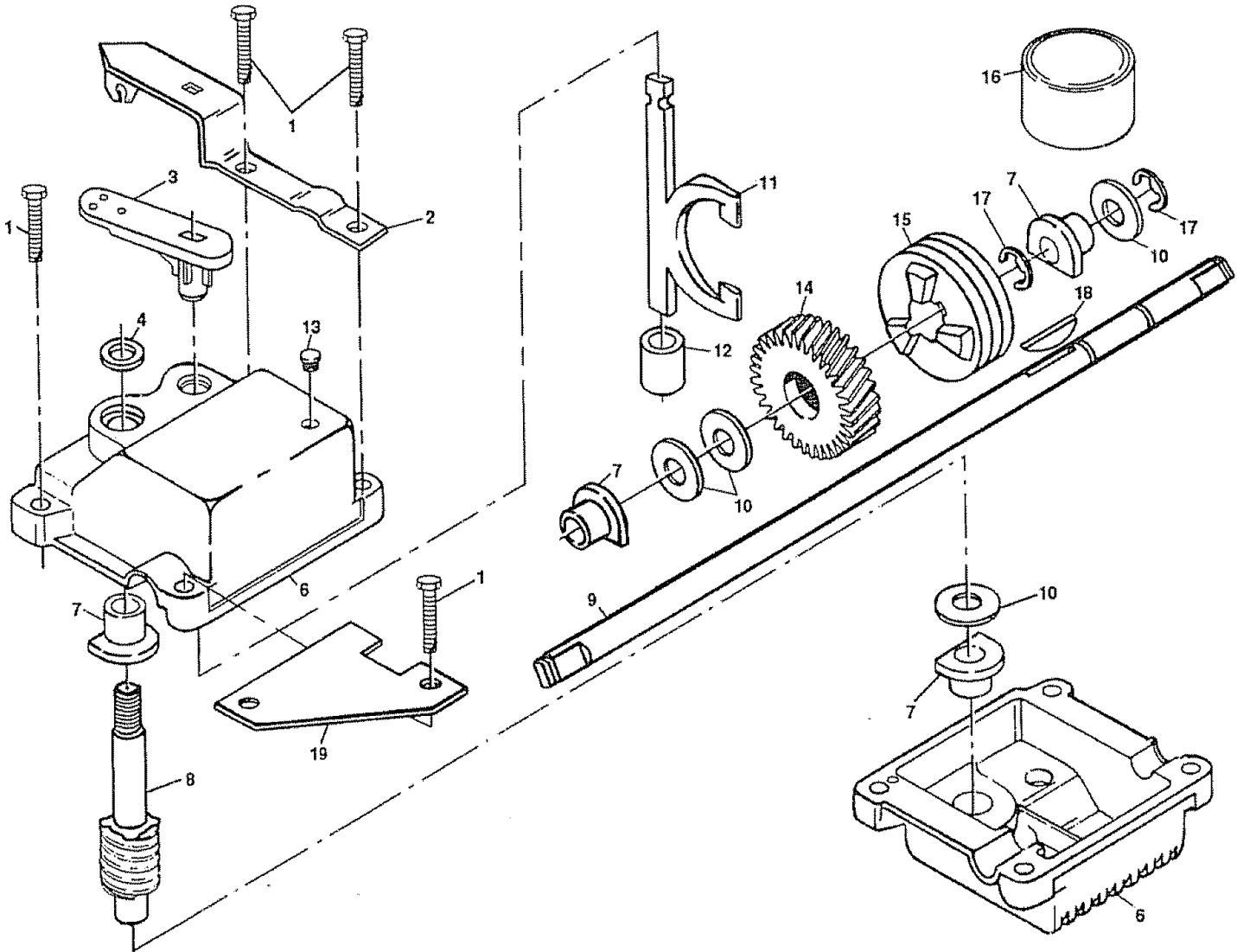

KEY NO.	PART NO.	DESCRIPTION
1	17490416	Tapping Screw 1/4-20 x 1-1/4
2	137055X004	Engagement Bracket
3	137053	Shifter
4	57072	Seal
6	48373	Gear Case Halves Kit (Includes Key Nos. 4, 5, and 7)
7	77881	Bearing
8	137051	Worm Shaft
9	137074	Drive Shaft
10	57079	Hardened Washer

KEY NO.	PART NO.	DESCRIPTION
11	131484	Clutch Yoke
12	700343	Bushing
13	86447	Plug
14	137050	Helical Gear
15	750436X	Clutch Jaw
16	750369	Grease
17	12000003	E-Ring
18	850848	Hi-Pro Key
19	81585X004	Spring Bracket

NOTE: All component dimensions given in U.S. inches.
1 inch = 25.4 mm

REPAIR PARTS

ROTARY LAWN MOWER - MODEL NO. 917.377210

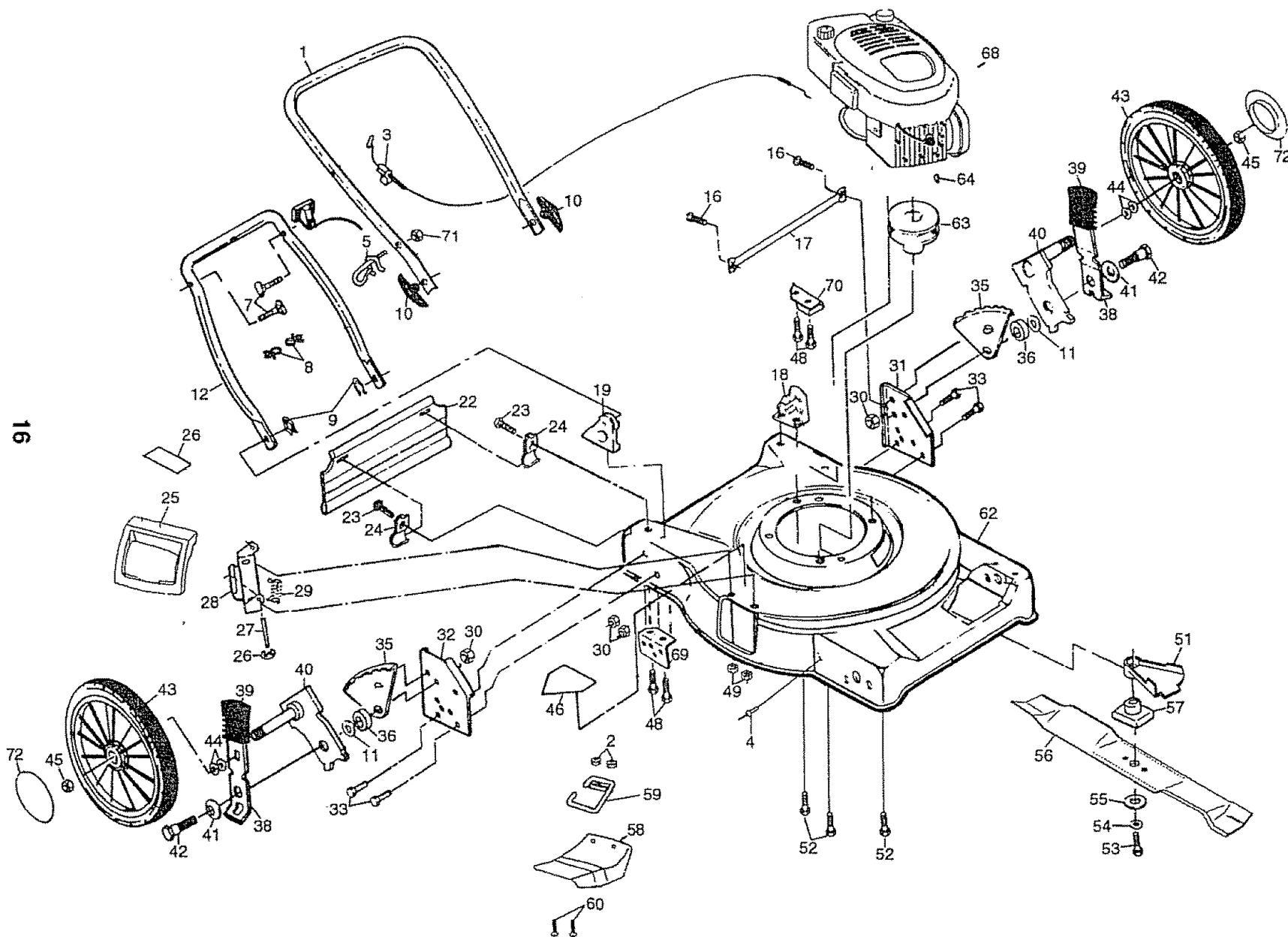

REPAIR PARTS

ROTARY LAWN MOWER - MODEL NO. 917.377210

KEY PART
NO. NO. DESCRIPTION

1 145646X479 Upper Handle
 2 STD541425 Locknut
 3 156577 Zone Control Cable
 5 153638 Rope Guide
 7 131959 Handle Bolt
 8 151517 Cable Clip
 9 51793 Hairpin Cotter
 10 136376 Handle Knob
 11 88348 Flat Washer 3/8
 12 151516X479 Lower Handle
 16 STD512505 Hex Tapping Screw 1/4-20 x 1/2
 17 750157 Support Rod
 18 151667X479 Handle Bracket Assembly (Left)
 19 151665X479 Handle Bracket Assembly (Right)
 22 140540 Rear Deflector
 23 750097 Hex Washer Head Screw #10-24 x 1/2
 24 87584X004 Deflector Bracket
 25 151889 Discharge Guard
 26 152904 Decal, Mulching Door
 27 147286 Hinge Rod
 28 154132 Housing Bracket
 29 152124 Torsion Spring
 30 751592 Locknut
 31 700168X479 Support Bracket (Left)
 32 700166X479 Support Bracket (Right)
 33 STD523707 Hex Head Bolt 3/8-16x3/4
 35 750085X007 Wheel Adjusting Bracket
 36 146630 Spacer
 38 700331X004 Selector Spring
 39 701037 Selector Knob
 40 750913X004 Axle Arm Assembly
 41 61651 Belleville Washer
 42 142748 Shoulder Bolt
 43 151138 Wheel & Tire Assembly

KEY PART
NO. NO. DESCRIPTION

44 57143 Wave Washer
 45 83923 Locknut 3/18-16
 46 85463 Danger Decal
 48 149741 Thread Cutting Screw 5/16-18 x 3/4
 49 STD541425 Hex Locknut
 51 134612 Debris Shield
 52 150406 Hex Head Thread Rolling Screw 3/8-16 x 1-1/8
 53 851084 Hex Head Screw 3/8-24 x 1-3/8 (Grd. 8)
 54 850263 Helical Lockwasher
 55 851074 Hardened Washer
 56 152202 Blade 22"
 57 851514 Blade Adapter
 58 752118 Deflector
 59 751399 Bracket, Deflector
 60 74180410 screw 1/4-20
 62 156516 Lawn Mower Housing (Incl. Ref. #46)
 63 85543 Engine Pulley
 64 87677 Hi-Pro Key #HP 505
 68 - - - - - Engine - (See Breakdown) Craftsman
 Model 143.976250
 69 153350X479 Support Brkt Handle RH
 70 153282X479 Support Brkt Handle LH
 71 63601 Locknut Keps
 72 151440 Hubcap
 -- 156525 Owner's Manual (English/Spanish)

Available accessories not included with lawn mower:

71 33072 Grass Catcher
71 33623 Gas Can (2.5 gal.)
71 33500 Fuel Stabilizer
71 33300 SAE 30W Oil (20 oz.)
71 33316 Mower Cover

REPAIR PARTS

ROTARY LAWN MOWER - MODEL NO. 917.377210

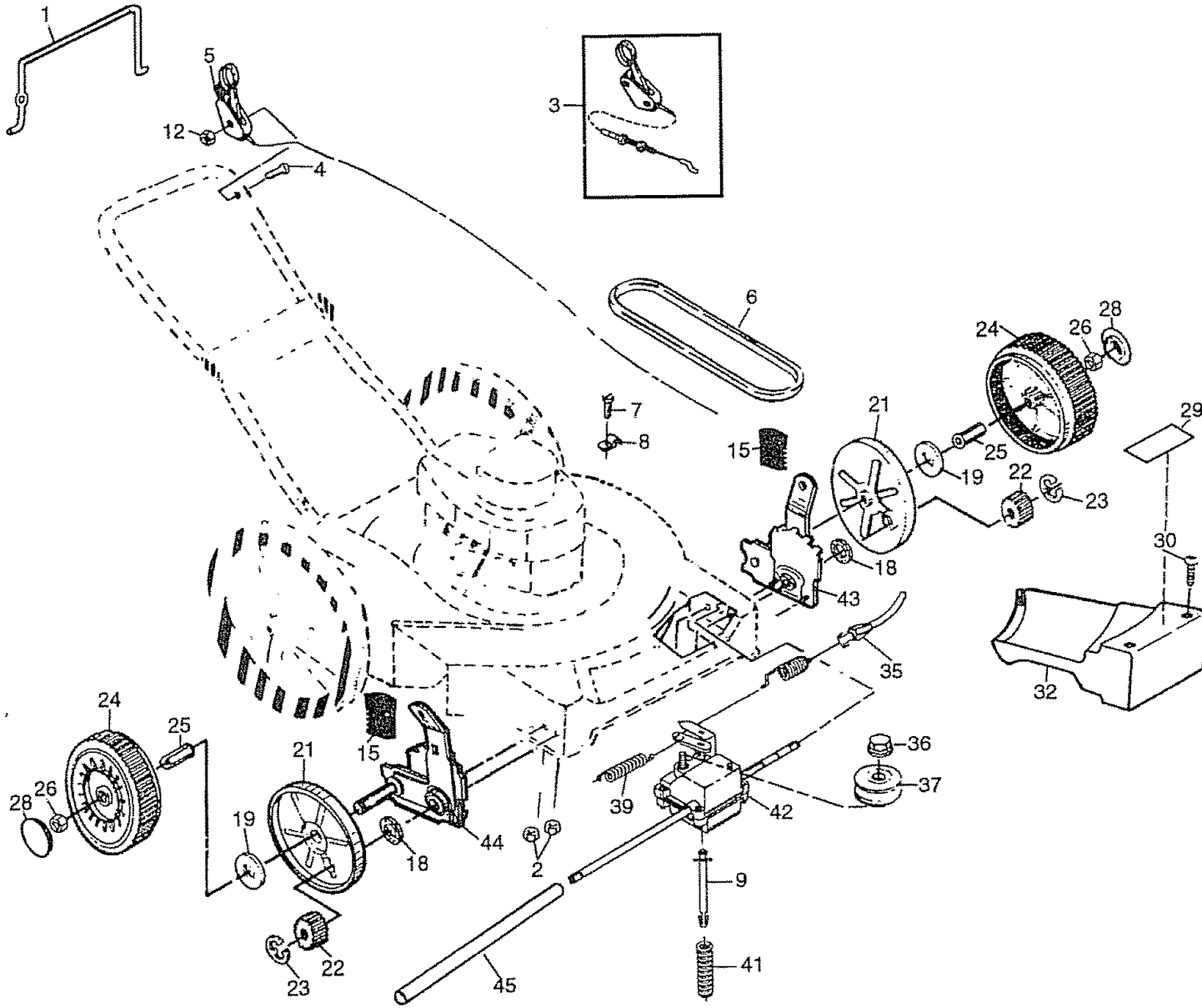

REPAIR PARTS

ROTARY LAWN MOWER - MODEL NO. 917.377210

KEY NO.	PART NO.	DESCRIPTION	KEY NO.	PART NO.	DESCRIPTION
1	145793	Control Bar	26	145212	Hex Flange Locknut
2	STD541425	Locknut 1/4-20	28	150182	Hubcap
3	48385	Control Head Kit	29	152903	Drive Cover decal
4	144929	Hex Washer Head Screw #10-24 x 2-1/8	30	143603	Pan Head Tapping Screw #10-24 x 2-3/4
5	146323	Control Cable Assembly	32	154990	Drive Cover
6	146527	V-Belt	35	48386	Drive Control Cable Kit
9	150495	Spring Retainer	36	132010	Locknut
12	63601	Locknut 1/4-20	37	137052	Drive Pulley
15	701037	Selector Knob	39	75192	Spring
18	88118	Felt Washer	41	137090	Spring
19	67725	Washer 1/2 x 1-1/2 x .134	42	702511	Gear Case Assembly (Composite)
21	88080	Dust Cover	43	152018	Wheel Adjuster Assembly (Left)
22	137054	Pinion	44	152019	Wheel Adjuster Assembly (Right)
23	12000058	E-Ring	45	86012	Driveshaft Cover
24	150340	Wheel & Tire Assembly			
25	88446	Wheel Bushing			

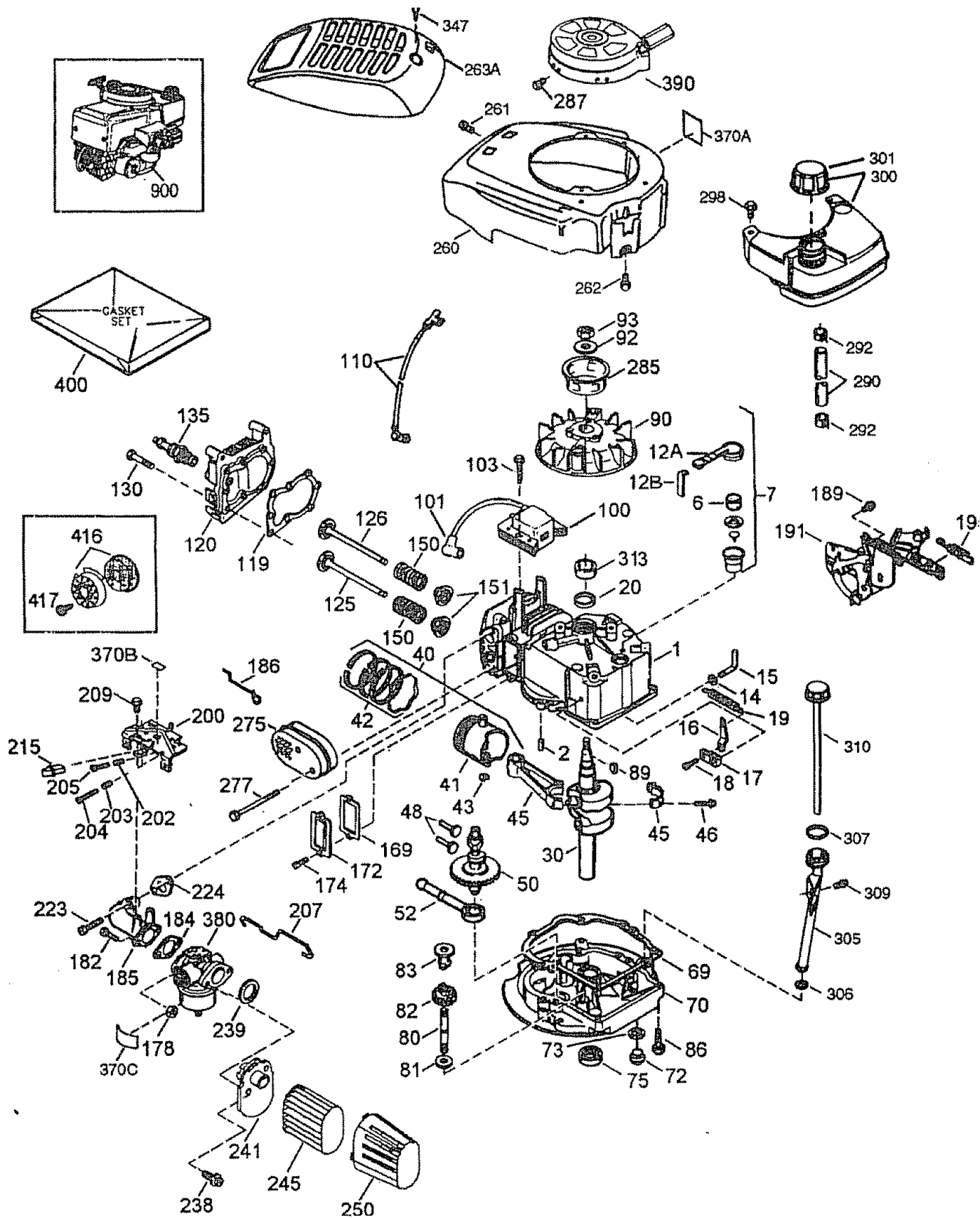

CRAFTSMAN 4-CYCLE ENGINE

MODEL NUMBER 143.976250

KEY PART NO. NO.	DESCRIPTION	KEY PART NO. NO.	DESCRIPTION
1 36478A	Cylinder (Incl. 2,7,20 & 125)	185 36544	Intake Pipe
2 26727	Dowel Pin	186 34337	Governor Link
6 33734	Breather Element	189 650839	Screw, 1/4-20 x 3/8"
7 36557	Breather Ass'y. (Incl. 6 & 12A)	191 36559	S.E. Brake Bracket (Incl. 195)
12A 36558	Breather Cover & Tube (Incl. 12B)	195 610973	Terminal
12B 34695	Breather Tube Elbow	200 35727	Control Bracket (Incl. 202 thru 205)
14 28277	Washer	202 36482	Compression Spring
15 30589	Governor Rod (Incl. 14)	203 31342	Compression Spring
16 32651	Governor Lever	204 650549	Screw, 5-40 x 7/16"
17 31335	Governor Lever Clamp	205 650777	Screw, 6-32 x 21/32"
18 651018	Screw, Torx T-15, 8-32 x 19/64"	207 34336	Throttle Link
19 36281	Extension Spring	209 30200	Screw, 10-24 x 9/16"
20 32600	Oil Seal	215 35511	Control Knob
30 35801	Crankshaft	223 650451	Screw, 1/4-20 x 1"
40 36073	Piston, Pin & Ring Set (Std.)	224 34690A	* Intake Pipe Gasket
40 36074	Piston, Pin & Ring Set (.010" OS)	238 650932	Screw, 10-32 x 49/64"
40 36075	Piston, Pin & Ring Set (.020" OS)	239 34338	* Air Cleaner Gasket
41 36070	Piston & Pin Ass'y. (Std.) (Incl. 43)	241 36919	Air Cleaner Collar
41 36071	Piston & Pin Ass'y. (.010" OS) (Incl. 43)	245 36905	Air Cleaner Filter
41 36072	Piston & Pin Ass'y. (.020" OS) (Incl. 43)	250 36920	Air Cleaner Cover
42 36076	Ring Set (Std.)	260 36915	Blower Housing
42 36077	Ring Set (.010" OS)	261 30200	Screw, 10-24 x 9/16"
42 36078	Ring Set (.020" OS)	262 650831	Screw, 1/4-20 x 1/2"
43 20381	Piston Pin Retaining Ring	263A 36921	Starter Grill
45 32875A	Connecting Rod Ass'y. (Incl. 46)	275 36473	Muffler (Incl. 277)
46 32610A	Connecting Rod Bolt	277 650988	Screw, 1/4-20 x 2-5/16"
48 27241	Valve Lifter	285 35000A	Starter Cup
50 35992	Camshaft (MCR)	287 650926	Screw, 8-32 x 21/64"
52 29914	Oil Pump Ass'y.	290 29774	Fuel Line
69 35261	* Mounting Flange Gasket	292 26460	Fuel Line Clamp
70 34311D	Mounting Flange (Incl. 72 thru 83)	298 28763	Screw, 10-32 x 35/64"
72 30572	Oil Drain Plug (Incl. 73)	300 36916	Fuel Tank (Incl. 292 & 301)
73 28833	Drain Plug Gasket	301 36246	Fuel Cap
75 27897	Oil Seal	305 35647	Oil Fill Tube
80 30574A	Governor Shaft	306 36832	* "O"-Ring
81 30590A	Washer	307 35499	"O"-Ring
82 30591	Governor Gear Ass'y. (Incl. 81)	309 650562	Screw, 10-32 x 1/2"
83 30588A	Governor Spool	310 35648	Dipstick
86 650488	Screw, 1/4-20 x 1-1/4"	313 34080	Spacer
89 611004	Flywheel Key	347 651038	Screw, 10-32 x 51/64"
90 611112	Flywheel	370A 36261	Lubrication Decal
92 650815	Belleville Washer	370B 35167	Control Decal
93 650816	Flywheel Nut	370C 36861	Primer Decal
100 34443A	Solid State Ignition	380 632747	Carburetor (Incl. 184)
101 610118	Spark Plug Cover	390 590702	Rewind Starter
103 651007	Screw, Torx T-15, 10-24 x 15/16"	400 36481	Gasket Set
110 34961	Ground Wire	416 36085	(Incl. Items Marked * in Notes)
119 36477	* Cylinder Head Gasket	417 650760	Spark Arrestor Kit
120 36476	Cylinder Head	900 —	(Incl. 416)(Optional)
125 36471	Exhaust Valve (Std.) (Incl. 151)	900 —	Screw, 8-32 x 3/8" (Optional)
125 36472	Exhaust Valve (1/32" OS) (Incl. 151)	— —	Replacement Engine 750784A, order from 71-999
126 29314B	Intake Valve (Std.) (Incl. 151)	— —	Replacement S/B 750670A, order from 71-999
126 29315C	Intake Valve (1/32" OS) (Incl. 151)	— —	RPM High 2900 to 3200
130 6021A	Screw, 5/16-18 x 1-1/2"	— —	RPM Low 2450 to 2750
135 35395	Resistor Spark Plug (RJ19LM)		
150 35991	Valve Spring		
151 31673	Valve Spring Cap		
169 27234A	* Valve Cover Gasket		
172 32755	Valve Cover		
174 30200	Screw, 10-24 x 9/16"		
178 29752	Nut & Lock Washer, 1/4-28		
182 6201	Screw, 1/4-28 x 7/8"		
184 26756	* Carburetor To Intake Pipe Gasket		

(NOTE: This engine could have been built with 590739 starter. Refer to the design of the rope pulley strength ribs for part identification. Individual starter parts do not interchange.) Incl. part #'s 26756 (1), 27234A (1), 33735 (1), 36832 (1), 34338 (1), 34690A (1), 35261 (1), 36477 (1)

NOTE: All component dimensions given in U.S. inches
1 inch = 25.4 mm

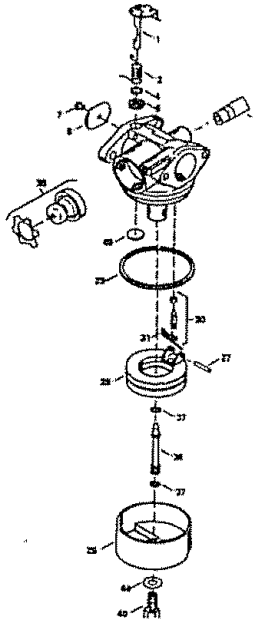

KEY PART NO.	NO.	DESCRIPTION
—	632747	Carburetor (Incl. 184 of Engine Parts List)
1	631615	Throttle Shaft & Lever Assembly
2	631767	Throttle Return Spring
4	631184	Dust Seal Washer
5	631183	Dust Seal (Throttle)
6	632504	Throttle Shutter
7	650506	Shutter Screw
16	631807	Fuel Fitting
25	631867	Float Bowl
27	631024	Float Shaft
28	632019	Float
29	631028	Float Bowl "O" Ring
30	631021	Inlet Needle, Seat, & Clip (Incl. 31)
31	631022	Spring Clip
35	36045	Primer Bulb/Retainer Ring
36	632735	Main Nozzle Tube
37	632547	"O" Ring, Main Nozzle Tube
40	632736	High Speed Bowl Nut
44	27110	Bowl Nut Washer
48	631027	Welch Plug, Atmospheric Vent

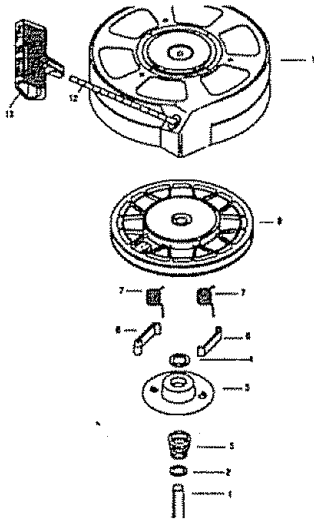

KEY PART NO.	NO.	DESCRIPTION
—	590702	Recoil Starter
1	590599A	Spring Pin (Incl. 4)
2	590600	Washer
3	590696	Retainer
4	590601	Washer
5	590697	Brake Spring
6	590698	Starter Dog
7	590699	Dog Spring
8	590700	Pulley & Rewind Spring Ass'y.
11	590703	Starter Housing Ass'y. (40 degree grommet)
12	590535	Starter Rope (98" X 9/64" dia.)
13	590701	Starter Handle

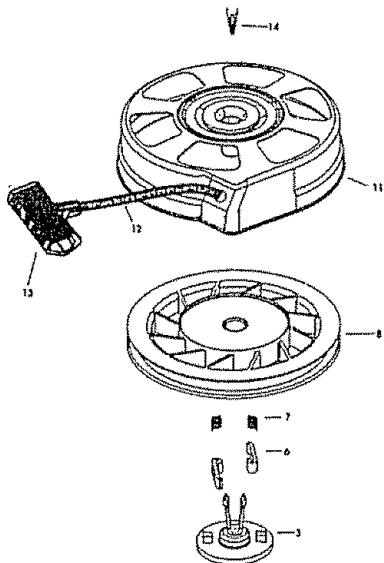

KEY PART NO.	NO.	DESCRIPTION
—	590739	Rewind Starter
3	590740	Retainer
6	590616	Starter Dog
7	590617	Dog Spring
8	590618A	Pulley & Rewind Spring Ass'y
11	590638	Starter Housing Ass'y (40 degree grommet)
12	590535	Starter Rope (Length 98" x 9/64" dia.)
13	590701	Starter Handle
14	590741	Locking Tab

NOTE: All component dimensions given in U.S. inches
1 inch = 25.4 mm

TROUBLESHOOTING POINTS

PROBLEM	CAUSE	CORRECTION
Does not start	<ol style="list-style-type: none"> 1. Dirty air filter. 2. Out of fuel. 3. Stale fuel. 4. Water in fuel. 5. Spark plug wire is disconnected. 6. Bad spark plug. 7. Loose blade or broken blade adapter. 8. Control bar in released position 9. Control bar defective 	<ol style="list-style-type: none"> 1. Clean/replace air filter. 2. Fill fuel tank. 3. Drain tank and refill with fresh clean fuel. 4. Drain fuel tank and carburetor and refill tank with fresh gasoline. 5. Connect wire to plug. 6. Replace spark plug. 7. Tighten blade bolt or replace blade adapter. 8. Depress control bar to handle. 9. Replace control bar.
Loss of power	<ol style="list-style-type: none"> 1. Rear of lawn mower housing/blade dragging in heavy grass. 2. Cutting too much grass. 3. Dirty air filter. 4. Buildup of grass, leaves and trash under mower. 5. Too much oil in engine. 6. Walking speed too fast. 	<ol style="list-style-type: none"> 1. Set in "Higher Cut" position. 2. Set in "Higher Cut" position. 3. Clean/replace air filter. 4. Clean underside of mower housing. 5. Check oil level. 6. Cut at slower walking speed.
Poor cut - uneven	<ol style="list-style-type: none"> 1. Worn, bent or loose blade. 2. Wheel heights uneven. 3. Low engine speed. 4. Buildup of grass, leaves, and trash under mower. 	<ol style="list-style-type: none"> 1. Replace blade. Tighten blade bolt. 2. Set all wheels at same height 3. Set engine speed control in fast position. 4. Clean underside of mower housing.
Excessive vibration	<ol style="list-style-type: none"> 1. Worn, bent or loose blade. 2. Bent engine crankshaft. 	<ol style="list-style-type: none"> 1. Replace blade. Tighten blade bolt. 2. Contact an authorized service center/department.
Starter rope hard to pull	<ol style="list-style-type: none"> 1. Engine flywheel brake is on when control bar is released. 2. Bent engine crankshaft 3. Blade adapter broken. 4. Blade dragging in grass. 	<ol style="list-style-type: none"> 1. Depress control bar to upper handle before pulling starter rope. 2. Contact an authorized service center/department. 3. Replace blade adapter. 4. Move lawn mower to cut grass or to hard surface to start engine.
Loss of drive (Self-Propelled Mowing)	<ol style="list-style-type: none"> 1. Drive wheels not turning with drive control engaged. 2. Belt not driving. 	<ol style="list-style-type: none"> 1. Adjust or replace drive control cable, if broken. 2. Put belt on pulleys or replace belts if broken.
Grass catcher not filling (If so equipped)	<ol style="list-style-type: none"> 1. Cutting height too low. 2. Lift on blade worn off. 3. Catcher not venting air. 4. Low engine speed. 	<ol style="list-style-type: none"> 1. Raise cutting height. 2. Replace blade. 3. Clean grass catcher 4. Set engine speed control in fast position.
Hard to push	<ol style="list-style-type: none"> 1. Grass is too high or wheel height is too low. 2. Rear of lawn mower housing/blade dragging in grass. 3. Grass catcher too full. 4. Handle height position not right for you. 	<ol style="list-style-type: none"> 1. Raise cutting height. 2. Raise rear of lawn mower housing one (1) setting higher. 3. Empty grass catcher. 4. Adjust handle height to suit.

SERVICE NOTES

Free Manuals Download Website

<http://myh66.com>

<http://usermanuals.us>

<http://www.somanuals.com>

<http://www.4manuals.cc>

<http://www.manual-lib.com>

<http://www.404manual.com>

<http://www.luxmanual.com>

<http://aubethermostatmanual.com>

Golf course search by state

<http://golfingnear.com>

Email search by domain

<http://emailbydomain.com>

Auto manuals search

<http://auto.somanuals.com>

TV manuals search

<http://tv.somanuals.com>