

Owner's Manual



# ROTARY LAWN MOWER

160cc Honda Engine

Power-Propelled

22" Multi-Cut

Model No.

**944.361361**



## **CAUTION:**

Read and follow all  
Safety Rules and Instructions  
before operating this equipment

Sears Canada, Inc., Toronto, Ontario M5B 2B8

# TABLE OF CONTENTS

Safety Rules .....	2-3	Maintenance .....	12-15
Warranty .....	4-5	Service and Adjustments .....	16-17
Product Specifications .....	5	Storage .....	17-18
Assembly/Pre-Operation .....	6	Troubleshooting .....	18-19
Operation .....	7-11	Repair Parts .....	20-29
Maintenance Schedule .....	12	Sears Service .....	Back Cover

## SAFETY RULES

**IMPORTANT:** This cutting machine is capable of amputating hands and feet and throwing objects. Failure to observe the following safety instructions could result in serious injury or death.

**⚠** Look for this symbol to point out important safety precautions. It means **CAUTION!!! BECOME ALERT!!! YOUR SAFETY IS INVOLVED.**

**⚠ WARNING:** In order to prevent accidental starting when setting up, transporting, adjusting or making repairs, always disconnect spark plug wire and place wire where it cannot come in contact with plug.

**⚠ CAUTION:** Muffler and other engine parts become extremely hot during operation and remain hot after engine has stopped. To avoid severe burns on contact, stay away from these areas.



### I. GENERAL OPERATION

- Read, understand, and follow all instructions on the machine and in the manual(s) before starting. Be thoroughly familiar with the controls and the proper use of the machine before starting.
- Do not put hands or feet near or under rotating parts. Keep clear of the discharge opening at all times.
- Only allow responsible individuals, who are familiar with the instructions, to operate the machine.
- Clear the area of objects such as rocks, toys, wire, bones, sticks, etc., which could be picked up and thrown by blade.
- Be sure the area is clear of other people before mowing. Stop machine if anyone enters the area.
- Do not operate the mower when barefoot or wearing open sandals. Always wear substantial foot wear.

- Do not pull mower backwards unless absolutely necessary. Always look down and behind before and while moving backwards.
- Never direct discharged material toward anyone. Avoid discharging material against a wall or obstruction. Material may ricochet back toward the operator. Stop the blade when crossing gravel surfaces.
- Do not operate the mower without proper guards, plates, grass catcher or other safety protective devices in place.
- See manufacturer's instructions for proper operation and installation of accessories. Only use accessories approved by the manufacturer.
- Stop the blade(s) when crossing gravel drives, walks, or roads.
- Stop the engine (motor) whenever you leave the equipment, before cleaning the mower or unclogging the chute.
- Shut the engine (motor) off and wait until the blade comes to complete stop before removing grass catcher.
- Mow only in daylight or good artificial light.
- Do not operate the machine while under the influence of alcohol or drugs.
- Never operate machine in wet grass. Always be sure of your footing: keep a firm hold on the handle; walk, never run.
- Disengage the self-propelled mechanism or drive clutch on mowers so equipped before starting the engine.
- If the equipment should start to vibrate abnormally, stop the engine (motor) and check immediately for the cause. Vibration is generally a warning of trouble.
- Always wear safety goggles or safety glasses with side shields when operating mower.

### II. SLOPE OPERATION

Slopes are a major factor related to slip & fall accidents which can result in severe injury. All slopes require extra caution. If you feel uneasy on a slope, do not mow it.

**DO:**

- Mow across the face of slopes: never up and down. Exercise extreme caution when changing direction on slopes.
- Remove obstacles such as rocks, tree limbs, etc.
- Watch for holes, ruts, or bumps. Tall grass can hide obstacles.

**DO NOT:**

- Do not trim near drop-offs, ditches or embankments. The operator could lose footing or balance.
- Do not trim excessively steep slopes.
- Do not mow on wet grass. Reduced footing could cause slipping.

**III. CHILDREN**

Tragic accidents can occur if the operator is not alert to the presence of children. Children are often attracted to the machine and the mowing activity. *Never* assume that children will remain where you last saw them.

- Keep children out of the trimming area and under the watchful care of another responsible adult.
- Be alert and turn machine off if children enter the area.
- Before and while walking backwards, look behind and *down* for small children.
- Never allow children to operate machine.
- Use extra care when approaching blind corners, shrubs, trees, or other objects that may obscure vision.

**IV. SAFE HANDLING OF GASOLINE**

Use extreme care in handling gasoline. Gasoline is extremely flammable and the vapors are explosive.

- Extinguish all cigarettes, cigars, pipes and other sources of ignition.
- Use only an approved container.
- Never remove gas cap or add fuel with the engine running. Allow engine to cool before refueling.
- Never refuel the machine indoors.
- Never store the machine or fuel container where there is an open flame, spark or pilot light such as a water heater or on other appliances.

- Never fill containers inside a vehicle, on a truck or trailer bed with a plastic liner. Always place containers on the ground away from your vehicle before filling.
- Remove gas-powered equipment from the truck or trailer and refuel it on the ground. If this is not possible, then refuel such equipment with a portable container, rather than from a gasoline dispenser nozzle.
- Keep the nozzle in contact with the rim of the fuel tank or container opening at all times until fueling is complete. Do not use a nozzle lock-open device.
- If fuel is spilled on clothing, change clothing immediately.
- Never overfill fuel tank. Replace gas cap and tighten securely.

**V. GENERAL SERVICE**

- Never run machine inside a closed area.
- Never make adjustments or repairs with the engine (motor) running. Disconnect the spark plug wire, and keep the wire away from the plug to prevent accidental starting.
- Keep nuts and bolts, especially blade attachment bolts, tight and keep equipment in good condition.
- Never tamper with safety devices. Check their proper operation regularly.
- Keep machine free of grass, leaves, or other debris build-up. Clean oil or fuel spillage. Allow machine to cool before storing.
- Stop and inspect the equipment if you strike an object. Repair, if necessary, before restarting.
- Never attempt to make wheel height adjustments while the engine is running.
- Grass catcher components are subject to wear, damage, and deterioration, which could expose moving parts or allow objects to be thrown. Frequently check components and replace with manufacturer's recommended parts, when necessary.
- Mower blades are sharp and can cut. Wrap the blade(s) or wear gloves, and use extra caution when servicing them.
- Do not change the engine governor setting or overspeed the engine.
- Maintain or replace safety and instruction labels, as necessary.

**⚠WARNING:** This lawn mower is equipped with an internal combustion engine and should not be used on or near any unimproved forest-covered, brush-covered or grass-covered land unless the engine's exhaust system is equipped with a spark arrester meeting applicable local or state laws (if any). If a spark arrester is used, it should be maintained in effective working order by the operator. A spark arrester for the muffler is available through your nearest Sears Service Centre (See the REPAIR PARTS section of this manual).

## WARRANTY

**GENERAL:** Craftsman products are warranted to be free from defects in materials or workmanship for a specific time period as set-out below (the "Warranty Period"). Warranties extend to the original purchaser of a Craftsman product only. Purchases made through an online auction or through any website other than [www.sears.ca](http://www.sears.ca) are excluded. The relevant Warranty Period commences on the original date of purchase. Within this period, Sears Canada, Inc. will, at its sole option, repair or replace any products or components which fail in normal use. Such repairs or replacement will be made at no charge to the customer for parts or labor, provided that the customer shall be responsible for any transportation cost.

**EXCLUSIONS:** This warranty does not cover failures due to normal wear, abuse, misuse, neglect (including but not limited to the use of stale fuel, dirt, abrasives, moisture, rust, corrosion, or any adverse reaction due to improper storage or use habits), improper maintenance or failure to follow maintenance guidelines and/or instructions, failure to operate the product in accordance with the owner's manual or any additional instructions or information provided at the time of purchase or in subsequent communications with the original purchaser, accident or unauthorized alterations or repairs made or attempted by others. Also excluded from warranty coverage – except as provided below - are the following: maintenance, adjustments, components subject to wear including but not limited to: cosmetic components, belts, blades, blade adapters, bulbs, tires, filters, guide bars, lubricants, seats, grips, recoil assy's, saw chains and bars, trimmer lines and spools, spark plugs, starter ropers and tines, and discoloration resulting from ultraviolet light. Any product missing the model and/or serial number identification label will be disqualified from coverage under this warranty.

**REPAIRS:** Repairs have a 90 day warranty. If the defective product is still within the Warranty Period, then the new warranty is 90 days from the date of repair or to the end of the original Warranty Period, whichever period is longer.

**DISCLAIMERS:** THE WARRANTIES AND REMEDIES CONTAINED HEREIN ARE EXCLUSIVE AND IN LIEU OF ALL OTHER WARRANTIES, WHETHER ORAL OR WRITTEN (OTHER THAN AS STATED HEREIN), AND WHETHER EXPRESS, IMPLIED OR STATUTORY, INCLUDING BUT NOT LIMITED TO ANY. THIS WARRANTY GIVES YOU SPECIFIC LEGAL RIGHTS, WHICH MAY VARY FROM PROVINCE TO PROVINCE.

IN NO EVENT SHALL SEARS BE LIABLE FOR ANY INCIDENTAL, SPECIAL, INDIRECT OR CONSEQUENTIAL DAMAGES, WHETHER RESULTING FROM THE USE, MISUSE OR INABILITY TO USE THE PRODUCT OR FROM DEFECTS IN THE PRODUCT. THE EXCLUSIONS IN THIS PARAGRAPH SHALL NOT APPLY IN JURISDICTIONS WHERE APPLICABLE LAW DOES NOT ALLOW FOR THE EXCLUSION OF INCIDENTAL OR CONSEQUENTIAL DAMAGES. IN SUCH JURISDICTIONS, THIS PARAGRAPH SHALL NOT APPLY, BUT THE REMAINING PROVISIONS OF THIS DOCUMENT SHALL REMAIN VALID.

Sears retains the exclusive right to repair or replace the product or offer a full refund of the purchase price at its sole discretion. SUCH REMEDY SHALL BE YOUR SOLE AND EXCLUSIVE REMEDY FOR ANY BREACH OF WARRANTY.

**CUSTOMER RESPONSIBILITIES:** In addition to complying with all suggested maintenance guidelines and instructions, customers' obligations shall include but shall not be limited to: operating the product in accordance with the owner's manual or any additional instructions or information provided at the time of purchase or in subsequent communications to the purchaser from time to time, exhibit reasonable care in the use, operation, maintenance, general upkeep and storage of the product. Failure to comply with these requirements will void any applicable warranty.

## WARRANTY

**LIST OF APPLICABLE WARRANTY PERIODS:** The following list contains the applicable Warranty Period for your Craftsman product and is based on a combination of the type of product or component and the intended and actual use of the product or component:

1. **90 DAYS:** Craftsman products intended for use or actually used for commercial, institutional, professional or income-producing purposes
2. **2 YEARS:** Craftsman riding lawn mowers, yard and garden tractors, walk behind mowers, tillers, brush cutters, snow blowers, handheld blowers, backpack blowers, hedge trimmers and electrical products for noncommercial, nonprofessional, non-institutional, or non-income-producing use, except for those components which are part of engine systems manufactured by third party engine manufacturers for which the purchase has received an separate warranty with product information supplied at the time of purchase.
3. **1 YEAR:** Craftsman power cutters, stump grinders, pole pruners, gas chain saws, electric chain saws, trimmer attachments, baggers and pole saws for noncommercial, nonprofessional, non-institutional, or non-income-producing use.
4. **90 DAYS:** All defective batteries, which will be replaced during this 90-day Warranty Period.
5. **60 DAYS:** Additional Warranty Period of 60 days will apply to adjustments and worn products or components BUT DOES NOT INCLUDE WEAR OR ADJUSTMENTS for products used for commercial, institutional, professional or income-producing purposes. Wear items include but are not limited to: belts, blades, tires, spark plugs, air filters, chains, shear bolts, skid plates, scraper bars, drift cutters, ropes, tines, collection bags and pulleys.

As the Warranty Period runs from the date of purchase and NOT from the date that a product is delivered, opened, assembled or first used, please ensure during this time period that your product or component has been assembled and tested for correction operation regardless of when you intend to actually use it. Claims made after the Warranty Period has expired will not be honored.

**PROOF OF PURCHASE/DOCUMENTATION:** Warranty coverage is conditioned upon the original purchaser furnishing Sears Canada or its authorized third party service provider if applicable, with the original sales receipt or other adequate written proof of the original purchase date and identification of the product. In the event that the original purchaser is unable to provide a company of the original sales receipt, Sears Canada Inc. reserves the right to determine in its sole discretion what other written proof of the original purchase date and identification of the product is acceptable.

## PRODUCT SPECIFICATIONS

Serial Number:	
Date of Purchase:	
Gasoline Capacity / Type:	0,94 Litres (Unleaded Regular)
Oil Capacity:	0,5 Litres
Oil Type (API SG–SL):	SAE 30 (above 0°C/32°F) or SAE 10W-30
Spark Plug (Gap: 0,76 mm)	NGK BPR6ES
Valve Clearance (± 0.04 mm):	Intake: 0.015 mm; Exhaust: 0.020 mm
Blade Bolt Torque:	35–40 ft. lbs.
• The model and serial numbers will be found on a decal on the rear of the lawn mower housing. Record both serial number and date of purchase in space provided above.	

## ASSEMBLY / PRE-OPERATION

Read these instructions and this manual in its entirety before you attempt to assemble or operate your new lawn mower.

**IMPORTANT:** This lawn mower is shipped WITHOUT OIL OR GASOLINE in the engine. Your new lawn mower has been assembled at the factory with the exception of those parts left unassembled for shipping purposes. To ensure safe and proper operation of your lawn mower, all parts and hardware you assemble must be tightened securely. Use the correct tools as necessary to ensure proper tightness. All parts such as nuts, washers, bolts, etc., necessary to complete the assembly have been placed in the parts bag.

### TO REMOVE MOWER FROM CARTON

1. Remove loose parts included with mower.
2. Cut down two end corners of carton and lay end panel down flat.
3. Remove all packing materials except padding between upper and lower handle and padding holding operator presence control bar to upper handle.
4. Roll lawn mower out of carton and check carton thoroughly for additional loose parts.

### HOW TO SET UP YOUR MOWER TO UNFOLD HANDLE

**IMPORTANT:** Unfold handle carefully so as not to pinch or damage control cables.

1. Raise handles until lower handle section locks into place in mowing position.
2. Remove protective padding, raise upper handle section into place on lower handle and tighten both handle knobs.
3. Remove handle padding holding operator presence control bar to upper handle.

Your lawn mower handle can be adjusted for your mowing comfort. Refer to "ADJUST HANDLE" in the Service and Adjustments section of this manual.

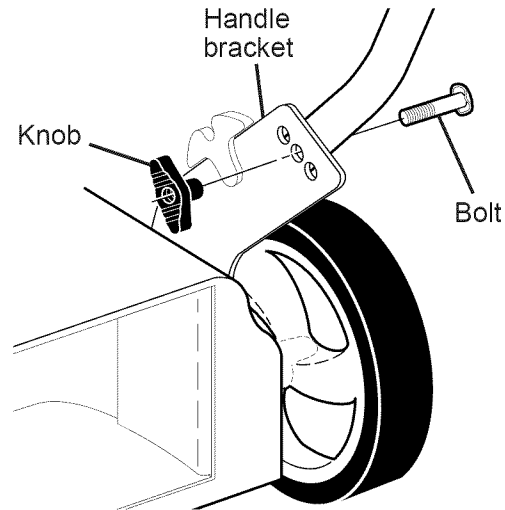
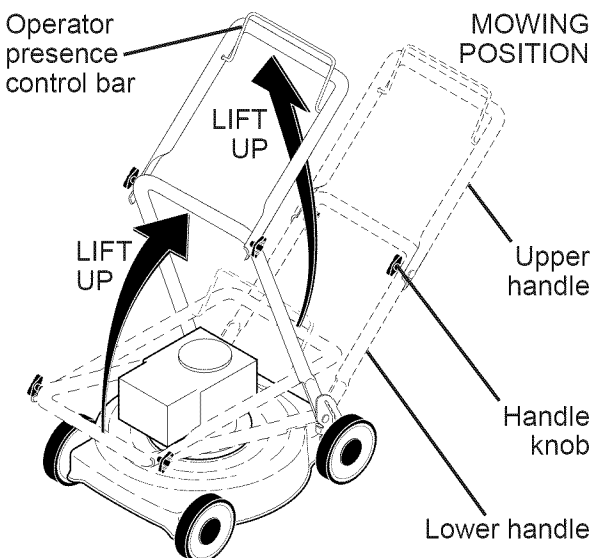

### TO ASSEMBLE GRASS CATCHER

1. Put grass catcher frame into grass bag with rigid part of bag on the bottom. Make sure the frame handle is outside of the bag top.
  2. Slip vinyl bindings over frame.
- NOTE:** If vinyl bindings are too stiff, hold them in warm water for a few minutes. If bag gets wet, let it dry before using.

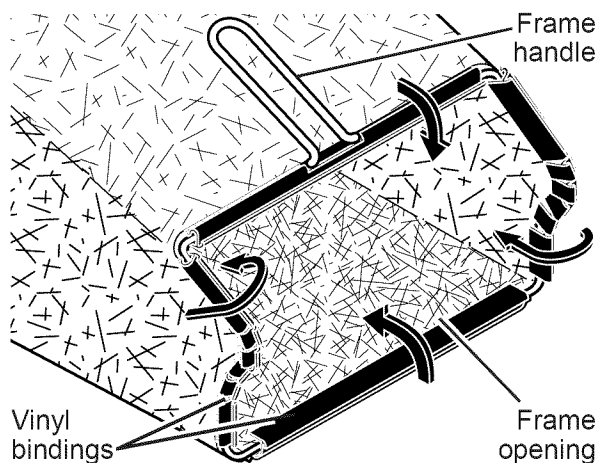

### TO INSTALL ATTACHMENTS

Your lawn mower was shipped ready to be used as a mulcher. To convert mower to bagging or discharging, see "TO CONVERT MOWER" in the Operation section of this manual.

# OPERATION

## KNOW YOUR LAWN MOWER

READ THIS OWNER'S MANUAL AND ALL SAFETY RULES BEFORE OPERATING YOUR LAWN MOWER. Compare the illustrations with your lawn mower to familiarize yourself with the location of various controls and adjustments. Save this manual for future reference.

These symbols may appear on your lawn mower or in literature supplied with the product. Learn and understand their meaning.

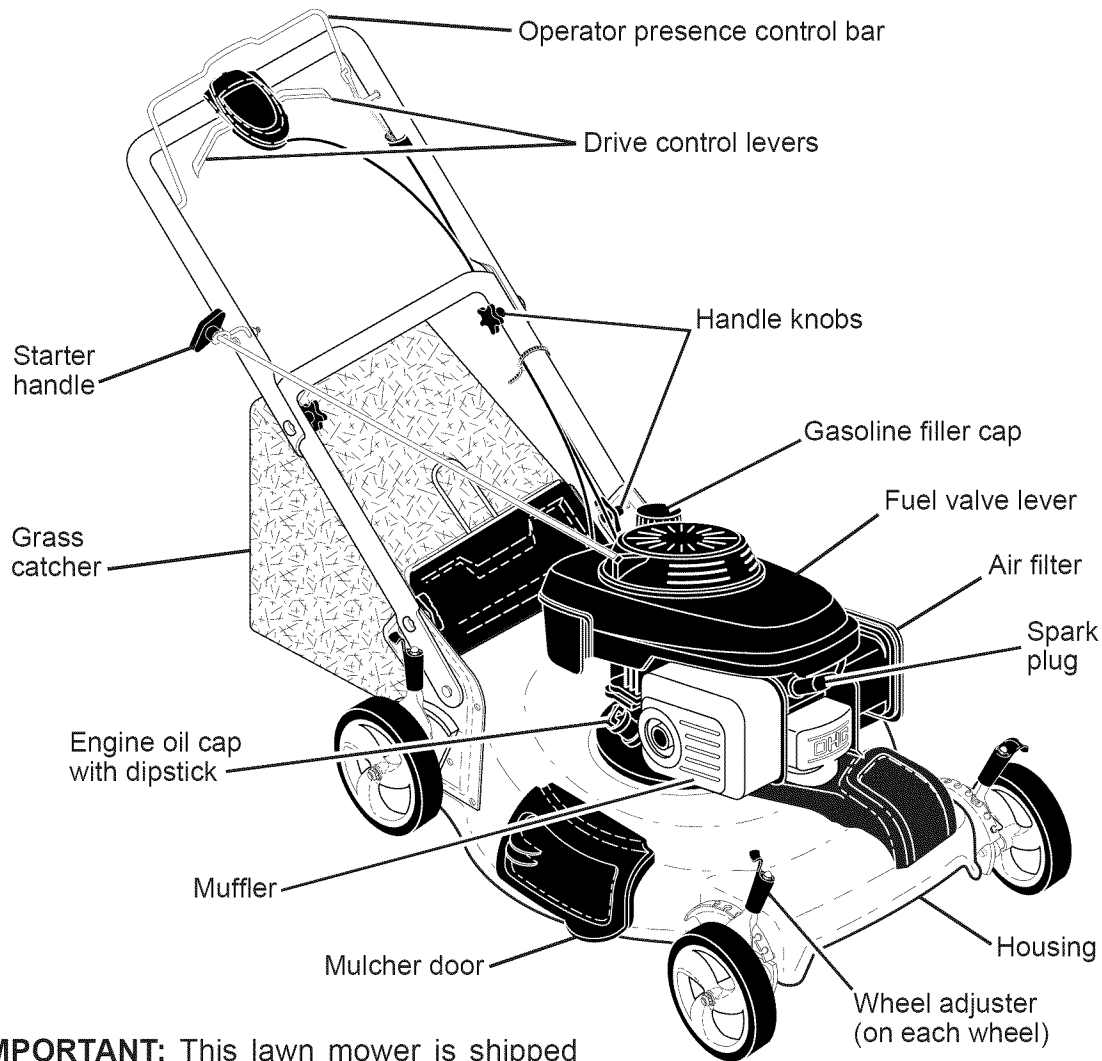
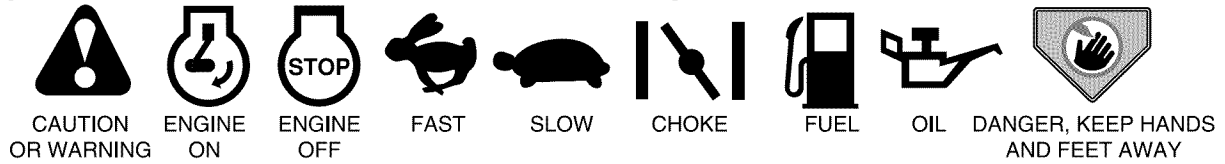

**IMPORTANT:** This lawn mower is shipped WITHOUT OIL OR GASOLINE in the engine.

### MEETS CPSC SAFETY REQUIREMENTS

Sears rotary walk-behind power lawn mowers conform to the safety standards of the American National Standards Institute and the U.S. Consumer Product Safety Commission. **⚠WARNING:** The blade turns when the engine is running.

**Operator presence control bar** – must be held down to the handle to start the engine. Release to stop the engine.  
**Starter handle** – used for starting engine.

**Drive control levers** – used to engage power-propelled forward motion of mower.  
**Mulcher door** – allows conversion to discharging or bagging operation.



The operation of any lawn mower can result in foreign objects thrown into the eyes, which can result in severe eye damage. Always wear safety glasses or eye shields while operating your lawn mower or performing any adjustments or repairs. We recommend a standard safety glasses or wide vision safety mask worn over spectacles.

## HOW TO USE YOUR LAWN MOWER ENGINE SPEED

Engine speed was set at the factory for optimum performance. It is not adjustable.

## ENGINE ZONE CONTROL

**CAUTION:** Federal regulations require an engine control to be installed on this lawn mower in order to minimize the risk of blade contact injury. Do not under any circumstances attempt to defeat the function of the operator control. The blade turns when the engine is running.

- Your lawn mower is equipped with an operator presence control bar which requires the operator to be positioned behind the lawn mower handle to start and operate the lawn mower.

## DRIVE CONTROL

- Self-propelling is controlled by holding the operator presence control bar down to the handle and pulling either drive control lever rearward to the handle. The further toward the handle a lever is pulled, the faster the unit will travel.
- Forward motion will stop when either the operator presence control bar or a drive control lever are released. To stop forward motion without stopping engine, release a drive control lever only. Hold operator presence control bar down against handle to continue mowing without self-propelling.

**NOTE:** If after releasing the drive control the mower will not roll backwards, push the mower forward slightly to disengage drive wheels.

Operator presence control bar

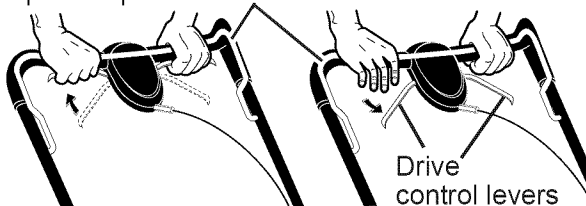

TO ENGAGE  
DRIVE CONTROL

DRIVE CONTROL  
DISENGAGED

## DRIVE CONTROL ADJUSTMENT

Over time, the drive control system may become "loose", resulting in decreased speed. There is a turnbuckle on the drive control housing to increase tension on the drive cable. Proceed as follows:

- Turn unit off and disconnect spark plug wire from spark plug.
- Rotate turnbuckle on drive control to increase drive speed.
- Operate mower to test drive speed. Readjust as required.
- If condition fails to improve after the above steps (forward speed remains the same), your drive belt is worn and should be replaced.

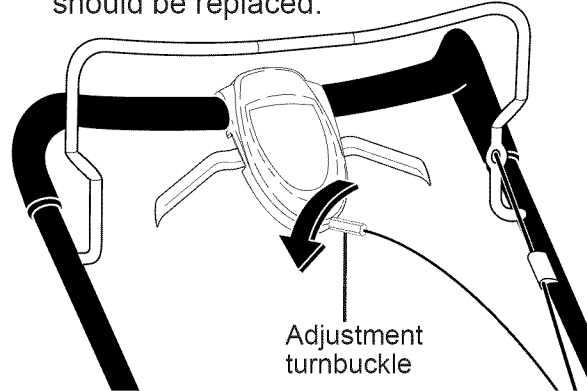

## TO ADJUST CUTTING HEIGHT

Raise wheels for low cut and lower wheels for high cut, adjust cutting height to suit your requirements. Medium position is best for most lawns.

- To change cutting height, pull up on adjuster lever, move wheel up or down to suit your requirements and release adjuster lever. Be sure all wheels are in the same setting.

**NOTE:** Adjuster is properly positioned when lever inserts into hole in plate.

LEVER BACKWARD  
TO LOWER MOWER

LEVER  
FORWARD  
TO RAISE MOWER

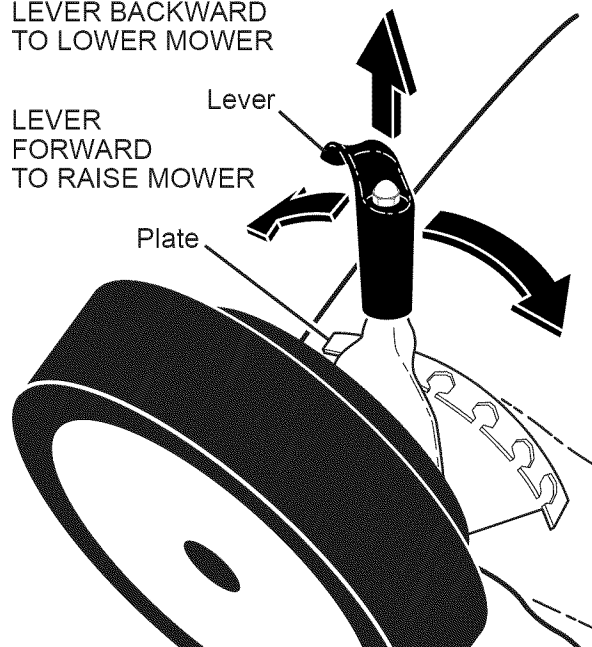



## TO CONVERT MOWER

Your lawn mower was shipped ready to be used as a mulcher. To convert to bagging or discharging:

### REAR BAGGING

- Lift rear door of the lawn mower and place the grass catcher frame hooks onto the grass bag brackets.
- To convert to mulching or discharging operation, remove grass catcher and close rear door.

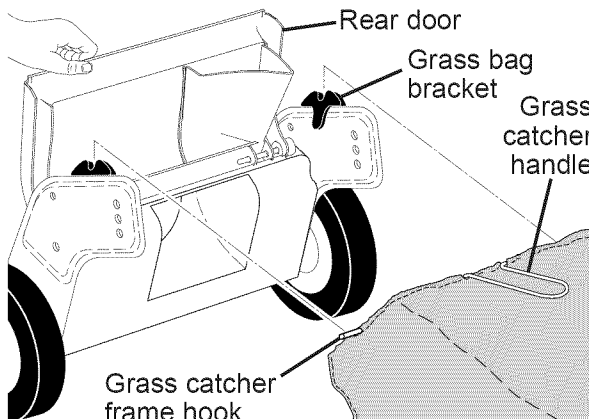

**NOTE:** Rear door will remain open until operator presence control bar is held down to the handle.

**CAUTION:** Do NOT force rear door to close. Serious damage to your mower could result.

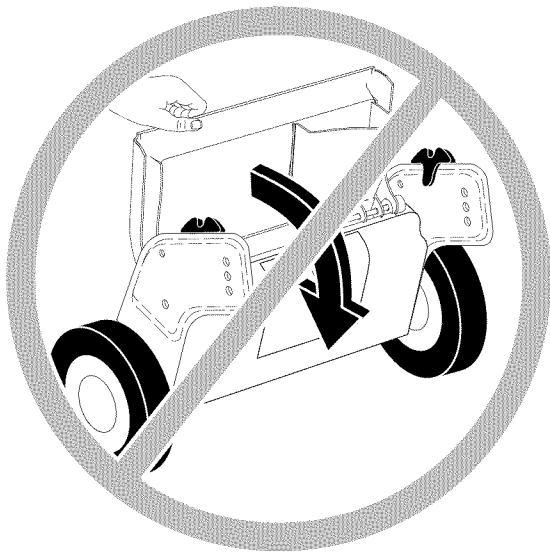

### SIDE DISCHARGING

- Rear door must be closed.
- Open mulcher door and install discharge deflector under door as shown.
- Mower is now ready for discharging operation.
- To convert to mulching or bagging operation, discharge deflector must be removed and mulcher door must be closed and locked.

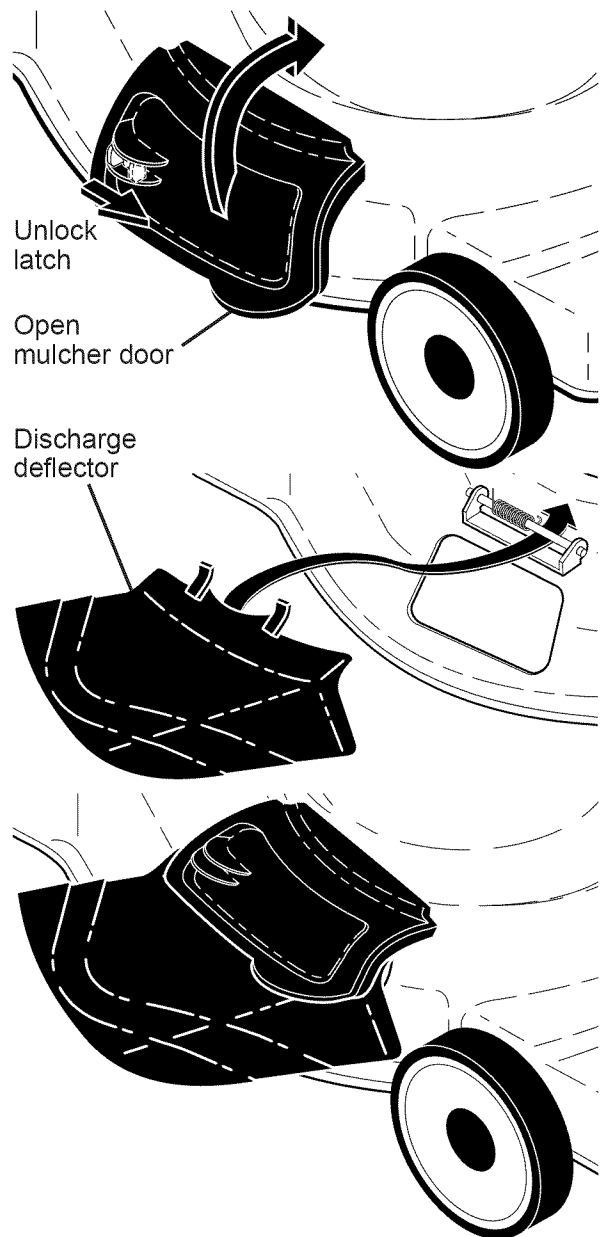

### SIMPLE STEPS TO REMEMBER WHEN CONVERTING YOUR LAWN MOWER

#### FOR MULCHING -

1. Rear door closed.
2. Mulcher door closed and locked.

#### FOR REAR BAGGING -

1. Grass catcher installed.
2. Mulcher door closed and locked.

#### FOR SIDE DISCHARGING -

1. Rear door closed.
2. Discharge deflector installed.

**CAUTION:** Do not run your lawn mower without rear door closed or approved grass catcher in place. Never attempt to operate the lawn mower with the rear door removed or propped open.

## TO EMPTY GRASS CATCHER

1. Lift up on grass catcher using the frame handle.
2. Remove grass catcher with clippings from under lawn mower handle.
3. Empty clippings from bag using both frame handle and bag handle.

**NOTE:** Do not drag the bag when emptying; it will cause unnecessary wear.

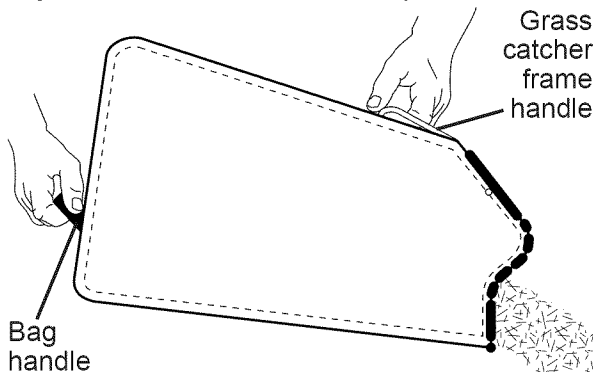

## BEFORE STARTING ENGINE

### ADD OIL

Your lawnmower is shipped without oil in the engine. For type and grade of oil to use, see “ENGINE” in the Maintenance section of this manual.

**CAUTION:** DO NOT overfill engine with oil, or it will smoke on startup.

1. Be sure lawnmower is level.
2. Remove oil fill cap/dipstick from oil fill spout.
3. You receive a container of oil with the unit. Slowly pour the entire container down the oil fill spout into the engine.
4. Insert and tighten oil fill cap/dipstick.

### IMPORTANT:

- Check oil level before each use. Add oil if needed. Fill to full line on dipstick.
- Change the oil after every 25 hours of operation or each season. You may need to change the oil more often under dusty, dirty conditions. See “TO CHANGE ENGINE OIL” in the Maintenance section of this manual.

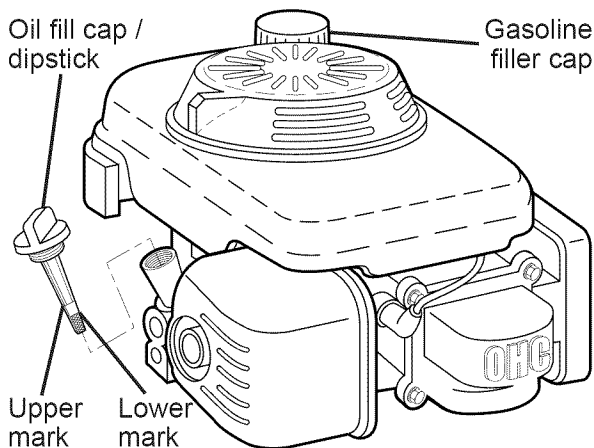

## ADD GASOLINE

- Fill fuel tank to bottom of tank filler neck. Do not overfill. Use fresh, clean, regular unleaded gasoline with a minimum of 87 octane. Do not mix oil with gasoline. Purchase fuel in quantities that can be used within 30 days to assure fuel freshness.

**CAUTION:** Wipe off any spilled oil or fuel. Do not store, spill or use gasoline near an open flame.

**CAUTION:** Alcohol blended fuels (called gasohol or using ethanol or methanol) can attract moisture which leads to separation and formation of acids during storage. Acidic gas can damage the fuel system of an engine while in storage. To avoid engine problems, the fuel system should be emptied before storage of 30 days or longer. Empty the gas tank, start the engine and let it run until the fuel lines and carburetor are empty. Use fresh fuel next season. See Storage Instructions for additional information. Never use engine or carburetor cleaner products in the fuel tank or permanent damage may occur.

## TO STOP ENGINE

- To stop engine, release operator presence control bar. Wait until blade and all moving parts have stopped and turn fuel valve to OFF position if you do not intend to restart the engine soon.

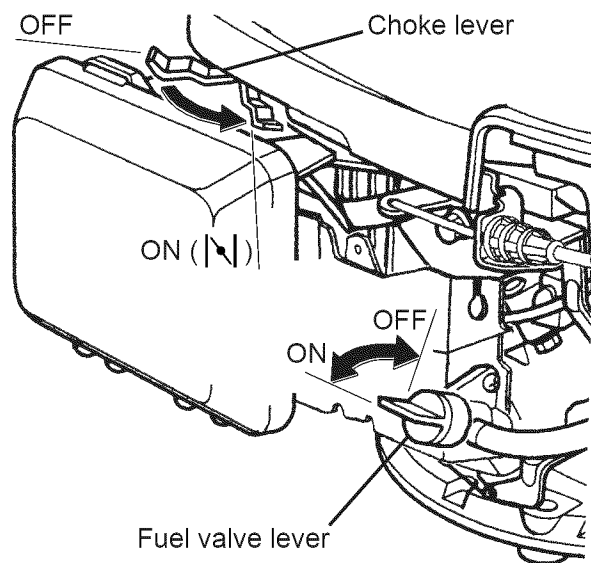

## TO START ENGINE

**NOTE:** Due to protective coatings on the engine, a small amount of smoke may be present during the initial use of the product and should be considered normal.

1. Be sure fuel valve is in the ON position.
2. Move choke lever to ON (  ) position.
3. Hold operator presence control bar down to the handle and pull starter handle quickly. Do not allow starter rope to snap back.

**NOTE:** The choke lever automatically begins moving to the OFF position when operator presence control bar is held down to handle.

## MOWING TIPS

**⚠ CAUTION:** Do not use de-thatcher blade attachments on your mower. Such attachments are hazardous, will damage your mower and could void your warranty.

- Under certain conditions, such as very tall grass, it may be necessary to raise the height of cut to reduce pushing effort and to keep from overloading the engine and leaving clumps of grass clippings. It may also be necessary to reduce ground speed and/or run the lawn mower over the area a second time.
- For extremely heavy cutting, reduce the width of cut by overlapping previously cut path and mow slowly.
- For better grass bagging and most cutting conditions, the engine speed should be set in the FAST position.
- Pores in cloth grass catchers can become filled with dirt and dust with use and catchers will collect less grass. To prevent this, regularly hose catcher off with water and let dry before using.
- Keep top of engine around starter clear and clean of grass clippings and chaff. This will help engine air flow and extend engine life.

## MULCHING MOWING TIPS

**IMPORTANT:** For best performance, keep mower housing free of built-up grass and trash. See “CLEANING” in the Maintenance section of this manual.

- The special mulching blade will recut the grass clippings many times and reduce them in size so that as they fall onto the lawn they will disperse into the grass and not be noticed. Also, the mulched grass will biodegrade quickly to provide nutrients for the lawn. Always mulch with your highest engine (blade) speed as this will provide the best recutting action of the blades.
- Avoid cutting your lawn when it is wet. Wet grass tends to form clumps and interferes with the mulching action. The best time to mow your lawn is the early afternoon. At this time the grass has dried, yet the newly cut area will not be exposed to direct sunlight.
- For best results, adjust the lawn mower cutting height so that the lawn mower cuts off only the top one-third of the grass blades. If the lawn is overgrown it will be necessary to raise the height of cut to reduce pushing effort and to keep from overloading the engine and leaving clumps of mulched grass. For extremely heavy grass, reduce your width of cut by overlapping previously cut path and mow slowly.

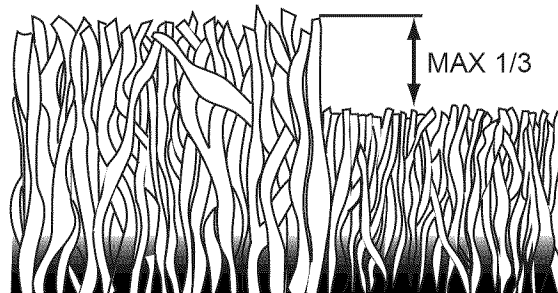

- Certain types of grass and grass conditions may require that an area be mulched a second time to completely hide the clippings. When doing a second cut, mow across (perpendicular) to the first cut path.
- Change your cutting pattern from week to week. Mow north to south one week then change to east to west the next week. This will help prevent matting and graining of the lawn.

# MAINTENANCE

<b>MAINTENANCE SCHEDULE</b>		BEFORE EACH USE	AFTER EACH USE	EVERY 10 HOURS	EVERY 25 HOURS OR SEASON	EVERY 100 HOURS	BEFORE STORAGE
<b>LAWN MOWER</b>	Check for Loose Fasteners	✓					✓
	Clean / Inspect Grass Catcher *	✓	✓				✓
	Check Tires	✓					
	Check Drive Wheels ***	✓					
	Clean Lawn Mower ****		✓				✓
	Clean under Drive Cover ***			✓			
	Check Drive Belt / Pulleys ***				✓		
	Check / Sharpen / Replace Blade				✓ <sub>3</sub>		
	Lubrication				✓		
	Clean and Recharge Battery **				✓		✓ <sub>4</sub>
<b>ENGINE</b>	Check Engine Oil level	✓ <sub>5</sub>					
	Change Engine Oil				✓ <sub>1,2</sub>		
	Clean Air Filter				✓ <sub>2</sub>		
	Inspect Muffler				✓		
	Replace Spark Plug					✓	
	Replace Air Filter Paper Cartridge					✓ <sub>2</sub>	
	Empty fuel system or add Stabilizer						✓

- \* (if so equipped)
- \*\* Electric-Start mowers
- \*\*\* Power-Propelled mowers
- \*\*\*\* Use a scraper to clean under deck
- 1 - Change more often if operating under a heavy load or in high outdoor temperatures.
- 2 - Service more often if operating in dirty or dusty conditions.
- 3 - Replace blades more often when mowing in sandy soil.
- 4 - Charge 48 hours at end of season.
- 5 - And after each 5 hours of use.

## GENERAL RECOMMENDATIONS

The warranty on this lawn mower does not cover items that have been subjected to operator abuse or negligence. To receive full value from the warranty, operator must maintain unit as instructed in this manual. Some adjustments will need to be made periodically to properly maintain your unit. At least once a season, check to see if you should make any of the adjustments described in the Service and Adjustments section of this manual.

- At least once a year, replace the spark plug, clean or replace air filter element and check blade for wear. A new spark plug and clean/new air filter element assure proper air-fuel mixture and help your engine run better and last longer.
- Follow the maintenance schedule in this manual.

## BEFORE EACH USE

- Check engine oil level.
- Check for loose fasteners.

## LUBRICATION

Keep unit well lubricated (See "LUBRICATION CHART").

## LUBRICATION CHART

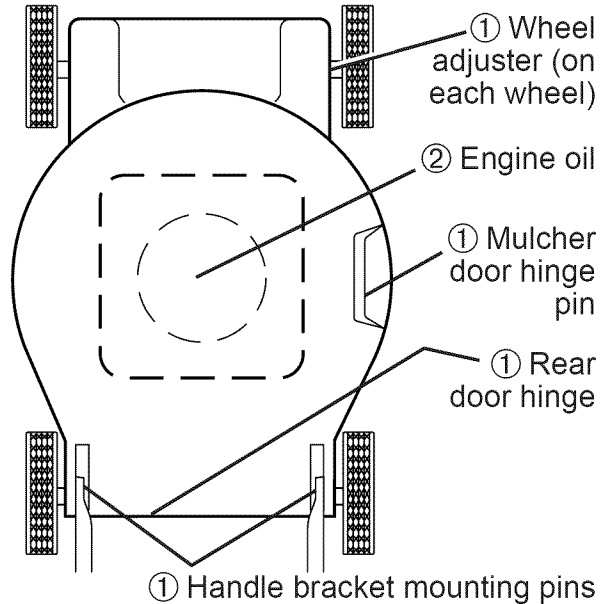

- ① Spray lubricant
- ② See "ENGINE" in Maintenance section.

**IMPORTANT:** Do not oil or grease plastic wheel bearings. Viscous lubricants will attract dust and dirt that will shorten the life of the self-lubricating bearings. If you feel they must be lubricated, use only a dry, powdered graphite type lubricant sparingly.

## LAWN MOWER

Always observe safety rules when performing any maintenance.

### TIRES

- Keep tires free of gasoline, oil, or insect control chemicals which can harm rubber.
- Avoid stumps, stones, deep ruts, sharp objects and other hazards that may cause tire damage.

### DRIVE WHEELS

Check rear drive wheels each time before you mow to be sure they move freely. The wheels not turning freely means trash, grass cuttings, etc. are in the drive wheel area and must be cleaned to free drive wheels. If necessary to clean the drive wheels, be sure to clean both rear wheels.

### BLADE CARE

For best results, mower blade must be kept sharp. Replace a bent or damaged blade.

**CAUTION:** Use only a replacement blade approved by the manufacturer of your mower. Using a blade not approved by the manufacturer of your mower is hazardous, could damage your mower and void your warranty.

#### TO REMOVE BLADE

1. Disconnect spark plug wire from spark plug and place wire where it cannot come in contact with plug.
2. Turn lawn mower on its side. Make sure air filter and carburetor are up.
3. Use a wood block between blade and mower housing to prevent blade from turning when removing blade bolt.

**NOTE:** Protect your hands with gloves and/or wrap blade with heavy cloth.

4. Remove blade bolt by turning counter-clockwise.
5. Remove blade and attaching hardware (bolt, lock washer and hardened washer).

**NOTE:** Remove the blade adapter and check the key inside hub of blade adapter. The key must be in good condition to work properly. Replace adapter if damaged.

#### TO REPLACE BLADE

1. Position the blade adapter on the engine crankshaft. Be sure key in adapter and crankshaft keyway are aligned.
2. Position blade on the blade adapter.

**IMPORTANT:** To ensure proper assembly, center hole in blade must align with star on blade adapter.

3. Be sure the trailing edge of blade (opposite sharp edge) is up toward the engine.
  4. Install the blade bolt with the lock washer and hardened washer into blade adapter and crankshaft.
  5. Use block of wood between blade and lawn mower housing and tighten the blade bolt, turning clockwise.
- The recommended tightening torque is 35–40 ft. lbs.

**IMPORTANT:** Blade bolt is heat treated. If bolt needs replacing, replace only with approved bolt shown in the Repair Parts section of this manual.

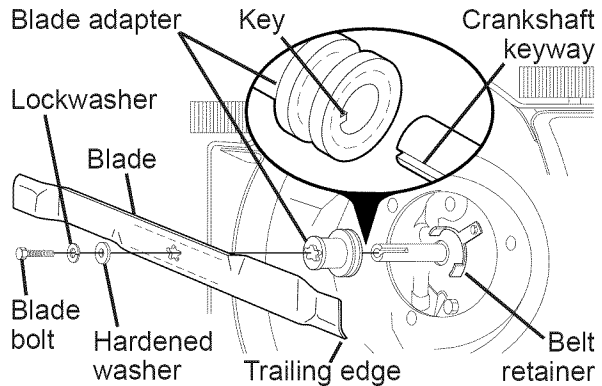

#### TO SHARPEN BLADE

**NOTE:** We do not recommend sharpening blade - but if you do, be sure the blade is balanced. An unbalanced blade will cause eventual damage to lawn mower or engine.

- The blade can be sharpened with a file or on a grinding wheel. Do not attempt to sharpen while on the mower.
- To check blade balance, you will need a 5/8" diameter steel bolt, pin, or a cone balancer. (When using a cone balancer, follow the instructions supplied with balancer.)

**NOTE:** Do not use a nail for balancing blade. The lobes of the center hole may appear to be centered, but are not.

- Slide blade on to an unthreaded portion of the steel bolt or pin and hold the bolt or pin parallel with the ground. If blade is balanced, it should remain in a horizontal position. If either end of the blade moves downward, sharpen the heavy end until the blade is balanced.

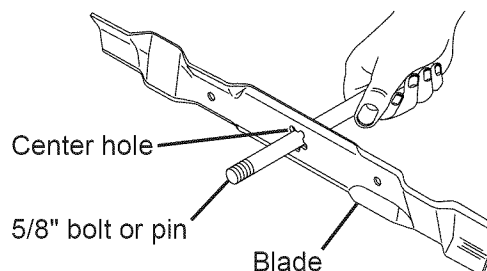

## GRASS CATCHER

- The grass catcher may be hosed with water, but must be dry when used.
- Check your grass catcher often for damage or deterioration. Through normal use it will wear. If catcher needs replacing, replace only with approved replacement catcher shown in the Repair Parts section of this manual. Give the lawn mower model number when ordering.

## GEAR CASE

- To keep your drive system working properly, the gear case and area around the drive should be kept clean and free of trash build-up. Clean under the drive cover twice a season.
- The gear case is filled with lubricant to the proper level at the factory. The only time the lubricant needs attention is if service has been performed on the gear case.

## ENGINE

Maintenance, repair, or replacement of the emission control devices and systems, which are being done at the customer's expense, may be performed by any non-road engine repair establishment or individual. Warranty repairs must be performed by an authorized engine manufacturer's service outlet.

## LUBRICATION

Use only high quality detergent oil rated with API service classification SG–SL. Select the oil's SAE viscosity grade according to your expected operating temperature.

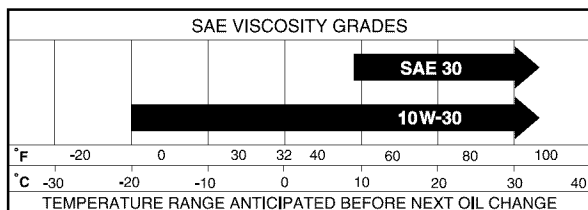

**NOTE:** Multi-viscosity oils (5W30, 10W30 etc.) improve starting in cold weather, and you should check your engine oil level frequently to avoid possible engine damage from running low on oil.

Change the oil after every 25 hours of operation or at least once a year if the lawn mower is not used for 25 hours in one year.

Check the crankcase oil level before starting the engine and after each five (5) hours of continuous use. Tighten oil plug securely each time you check the oil level.

## TO CHANGE ENGINE OIL

**NOTE:** Before tipping lawn mower to drain oil, empty fuel tank by running engine until fuel tank is empty.

1. Disconnect spark plug wire from spark plug and place wire where it cannot come in contact with plug.
2. Remove oil fill cap/dipstick; lay aside on a clean surface.
3. Tip lawn mower on its side as shown and drain oil into a suitable container. Rock lawn mower back and forth to remove any oil trapped inside of engine.



4. Wipe off any spilled oil from lawn mower or side of engine.
5. Fill engine with oil. Slowly pour oil down the oil fill spout into the engine.
6. Wait one minute to allow oil to settle. Use gauge on oil fill cap/dipstick for checking level. Insert dipstick into the tube and rest the oil fill cap on the tube. DO NOT thread the cap into the tube when taking reading.

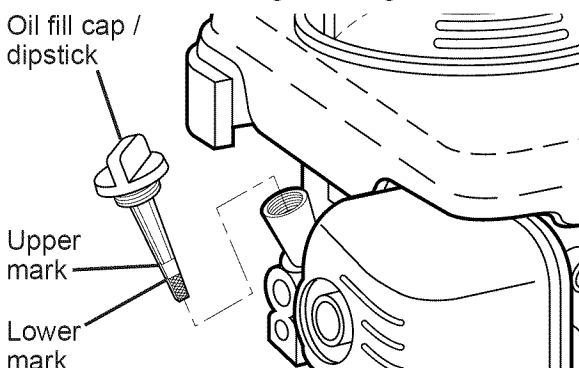

7. Continue adding small amounts of oil and rechecking the dipstick until it reads full. DO NOT overfill, or engine will smoke on startup.
8. Always be sure to retighten oil fill cap/dipstick before starting engine.
9. Reconnect spark plug wire to spark plug.

## AIR FILTER

Your engine will not run properly and may be damaged by using a dirty air filter. Replace the air filter every 100 hours of operation or every season, whichever occurs first. Service air cleaner more often under dusty conditions.

## TO CLEAN AIR FILTER

1. Remove cover.
2. Carefully remove cartridge.
3. Clean by gently tapping on a flat surface. If very dirty, replace cartridge.

**⚠CAUTION:** Petroleum solvents, such as kerosene, are not to be used to clean cartridge. They may cause deterioration of the cartridge. Do not oil cartridge. Do not use pressurized air to clean or dry cartridge.

4. Install cartridge, then replace cover.

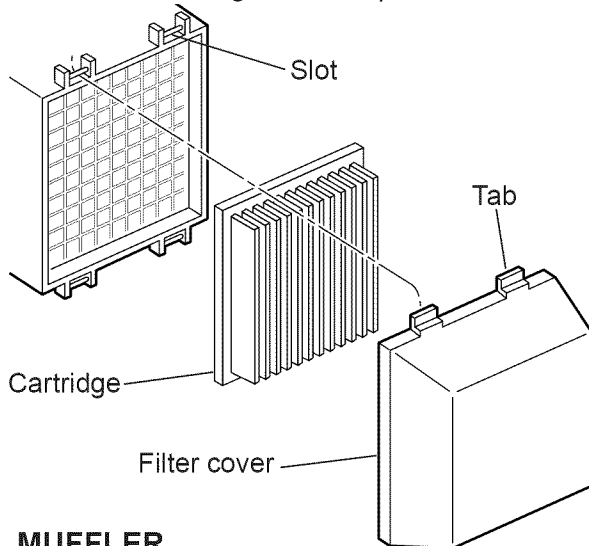

## MUFFLER

Inspect and replace corroded muffler as it could create a fire hazard and/or damage.

## SPARK PLUG

Replace spark plug at the beginning of each mowing season or after every 100 hours of operation, whichever occurs first. Spark plug type and gap setting are shown in the "PRODUCT SPECIFICATIONS" section of this manual.

## CLEANING

**IMPORTANT:** For best performance, keep mower housing free of built-up grass and trash. Clean the underside of your mower after each use.

**⚠CAUTION:** Disconnect spark plug wire from spark plug and place wire where it cannot come in contact with spark plug.

- Clean the underside of your lawn mower by scraping to remove build-up of grass and trash.
- Clean engine often to keep trash from accumulating. A clogged engine runs hotter and shortens engine life.
- Keep finished surfaces and wheels free of all gasoline, oil, etc.
- We do not recommend using a garden hose to clean lawn mower unless the electrical system, muffler, air filter and carburetor are covered to keep water out. Water in engine can result in shortened engine life.

## WATER WASHOUT FEATURE

Your lawn mower is equipped with a fitting that allows quick and easy cleaning of the underside of the housing. To use this feature, proceed as follows:

1. Move lawn mower to an area of cut grass or another hard surface.

**NOTE:** Water, grass and other debris will drain from beneath the mower housing during the washout process.

2. Remove grass catcher and discharge chute assembly from lawn mower.
3. Close mulcher door (if equipped).
4. Connect a garden hose to the fitting where shown.

**IMPORTANT:** Be sure the garden hose is not routed under the lawn mower housing or entangled in the wheels.

5. Turn on water supply and check for leaks at the fitting.

If no leaks are present, start engine (as described in the Operation section of this manual) and let engine run until the underside of the lawn mower is clean.

**⚠WARNING:** Do not engage the drive system during the washout process.

6. Shut off the engine.
7. Shut off water supply and remove hose from fitting.

**CAUTION:** Do not remove hose from fitting while engine is running. Water in engine can result in shortened engine life.

8. Start engine (as described in the Operation section of this manual) and let engine run for a full minute to remove excess water from mower.

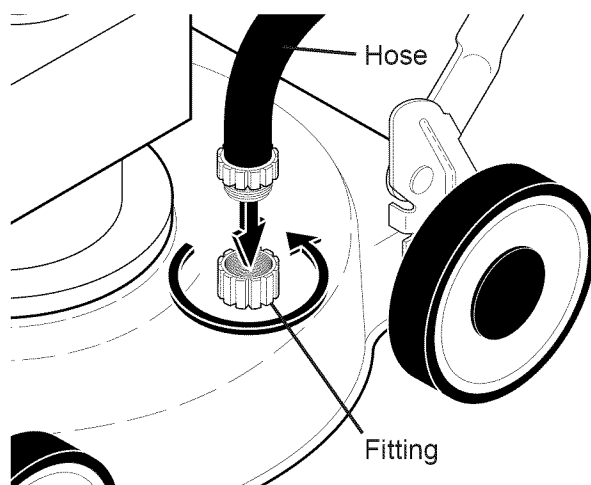

## CLEAN UNDER DRIVE COVER

Clean under drive cover at least twice a season. Scrape underside of cover with putty knife or similar tool to remove any build-up of trash or grass on underside of drive cover.

# SERVICE AND ADJUSTMENTS

**⚠ WARNING:** To avoid serious injury, before performing any service and adjustments:

1. Release control bar and stop engine.
2. Make sure the blade and all moving parts have completely stopped.
3. Disconnect spark plug wire from spark plug and place wire where it cannot come in contact with plug.

## LAWN MOWER

### TO ADJUST CUTTING HEIGHT

See "TO ADJUST CUTTING HEIGHT" in the Operation section of this manual.

### REAR DEFLECTOR

The rear deflector, attached between the rear wheels of your mower, is provided to minimize the possibility that objects will be thrown out of the rear of the mower into the operator mowing position. If the deflector becomes damaged, it should be replaced.

### TO REMOVE DRIVE BELT

1. Remove drive cover and belt keeper.
2. Remove belt from gearcase pulley.
3. Turn lawn mower on its side with air filter and carburetor down.
4. Remove blade and blade adapter.
5. Remove belt from engine pulley.

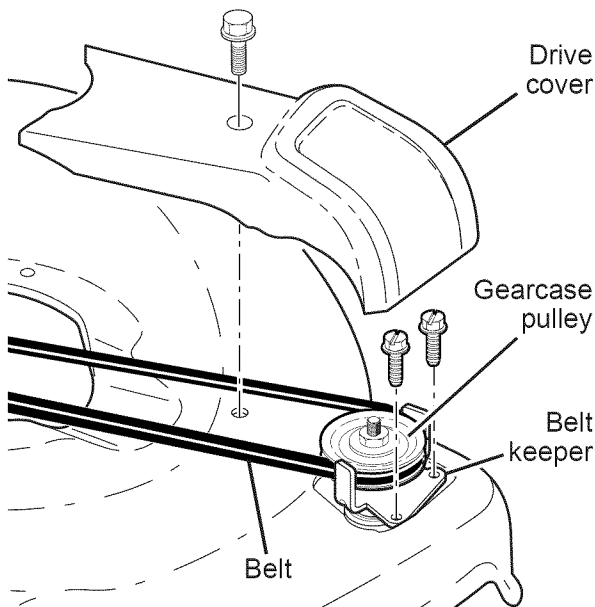

### TO REPLACE DRIVE BELT

1. Place new drive belt on engine pulley, inside tabs of belt retainer.
2. Route the other end of the new drive belt through hole in housing.
3. Reinstall blade adapter and blade.
4. Return mower to upright position.
5. Install new belt on gearcase pulley.

6. Reinstall belt keeper and drive cover.

**NOTE:** Always use factory approved belt to assure proper fit and long life.

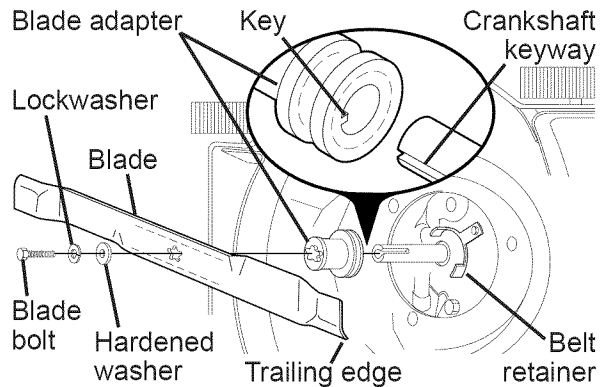

### TO ADJUST HANDLE

Your handle has three (3) height positions - adjust to a height that suits you.

1. Remove knob and carriage bolt on one side of the lower handle.
2. While holding handle assembly, remove knob and carriage bolt from opposite side, align hole in handle with desired hole in handle bracket and reassemble bolt and knob and tighten securely.
3. Align opposite side of handle with same positioning hole and secure with bolt and knob.

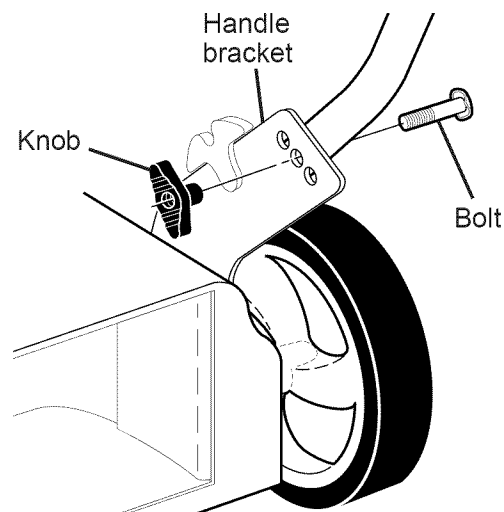



## ENGINE

Maintenance, repair, or replacement of the emission control devices and systems, which are being done at the customer's expense, may be performed by any non-road engine repair establishment or individual. Warranty repairs must be performed by an authorized engine manufacturer's service outlet.

## ENGINE SPEED

Your engine speed has been factory set. Do not attempt to increase engine speed or it may result in personal injury. If you believe that engine is running too fast or too slow, take your mower to a Sears or other qualified service center for repair and adjustment.

## CARBURETOR

Your carburetor is not adjustable. If your engine does not operate properly due to suspected carburetor problems, take your lawn mower to a Sears or other qualified service center for repair and/or adjustment.

**IMPORTANT:** Never tamper with the engine governor, which is factory set for proper engine speed. Overspeeding the engine above the factory high speed setting can be dangerous. If you think the engine-governed high speed needs adjusting, contact a Sears or other qualified service center, which has proper equipment and experience to make any necessary adjustments.

## STORAGE

Immediately prepare your lawn mower for storage at the end of the season or if the unit will not be used for 30 days or more.

## LAWN MOWER

When lawn mower is to be stored for a period of time, clean it thoroughly, remove all dirt, grease, leaves, etc. Store in a clean, dry area.

1. Clean entire lawn mower (See "CLEANING" in the Maintenance section of this manual).
2. Lubricate as shown in the Maintenance section of this manual.
3. Be sure that all nuts, bolts, screws, and pins are securely fastened. Inspect moving parts for damage, breakage and wear. Replace if necessary.
4. Touch up all rusted or chipped paint surfaces; sand lightly before painting.

## HANDLE

You can fold your handle for storage.

1. Loosen the two (2) handle knobs on sides of the upper handle and allow handle to fold down to the rear.
  2. Remove the two (2) handle knobs and carriage bolts on sides of the lower handle and pivot entire handle assembly forward and allow it to rest on mower.
  3. Reinstall knobs and carriage bolts to lower handle / handle brackets for safe keeping.
- When setting up your handle from the storage position, lower handle will require manually locking into mowing position.

**IMPORTANT:** When folding the handle for storage or transportation, be sure to fold the handle as shown or you may damage the control cables.

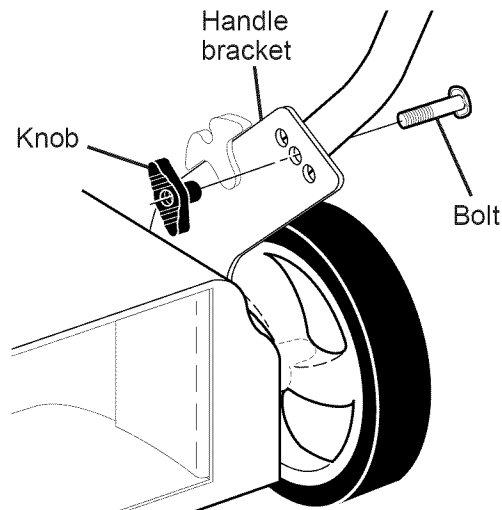
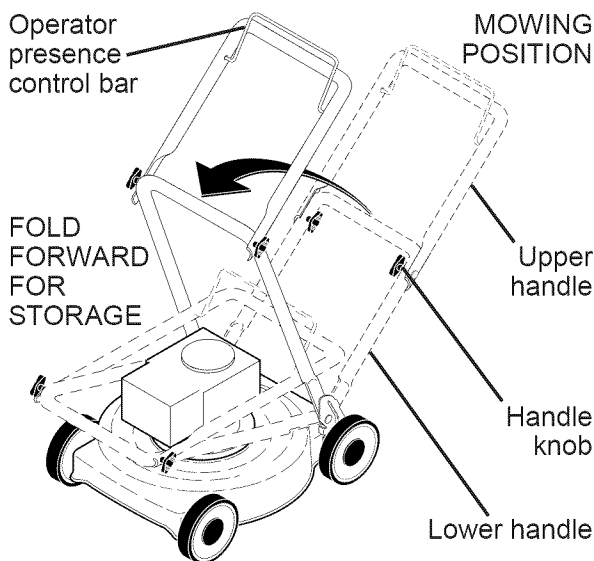

## ENGINE

### FUEL SYSTEM

**IMPORTANT:** It is important to prevent gum deposits from forming in essential fuel system parts such as carburetor, fuel filter, fuel hose, or tank during storage. Alcohol blended fuels (called gasohol or using ethanol or methanol) can attract moisture which leads to separation and formation of acids during storage. Acidic gas can damage the fuel system of an engine while in storage.

- Empty the fuel tank by starting the engine and letting it run until the fuel lines and carburetor are empty.
- Never use engine or carburetor cleaner products in the fuel tank or permanent damage may occur.
- Use fresh fuel next season.

**NOTE:** Fuel stabilizer is an acceptable alternative in minimizing the formation of fuel gum deposits during storage. Add stabilizer to gasoline in fuel tank or storage container. Always follow the mix ratio found on stabilizer container. Run engine at least 10 minutes after adding stabilizer to allow the stabilizer to reach the carburetor. Do not empty the gas tank and carburetor if using fuel stabilizer.

## ENGINE OIL

Drain oil (with engine warm) and replace with clean engine oil. (See "ENGINE" in the Maintenance section of this manual).

### CYLINDER

1. Remove spark plug.
2. Pour one ounce (29 ml) of oil through spark plug hole into cylinder.
3. Pull starter handle slowly a few times to distribute oil.
4. Replace with new spark plug.

### OTHER

- Do not store gasoline from one season to another.
- Replace your gasoline can if your can starts to rust. Rust and/or dirt in your gasoline will cause problems.
- If possible, store your unit indoors and cover it to protect it from dust and dirt.
- Cover your unit with a suitable protective cover that does not retain moisture. Do not use plastic. Plastic cannot breathe, which allows condensation to form and will cause your unit to rust.

**IMPORTANT:** Never cover mower while engine and exhaust areas are still warm.

**CAUTION:** Never store the lawn mower with gasoline in the tank inside a building where fumes may reach an open flame or spark. Allow the engine to cool before storing in any enclosure.

**TROUBLESHOOTING - See appropriate section in manual unless directed to a Sears Parts & Repair Centre.**

PROBLEM	CAUSE	CORRECTION
Does not start	<ol style="list-style-type: none"><li>1. Dirty air filter.</li><li>2. Out of fuel.</li><li>3. Stale fuel.</li><li>4. Water in fuel.</li><li>5. Spark plug wire is disconnected.</li><li>6. Bad spark plug.</li><li>7. Loose blade or broken blade adapter.</li><li>8. Control bar in released position.</li><li>9. Control bar defective.</li><li>10. Fuel valve lever (if so equipped) in OFF position.</li><li>11. Weak battery (if equipped).</li><li>12. Disconnected battery connector (if equipped).</li><li>13. Blown fuse (if equipped).</li></ol>	<ol style="list-style-type: none"><li>1. Clean/replace air filter.</li><li>2. Fill fuel tank.</li><li>3. Empty fuel tank and refill tank with fresh, clean gasoline.</li><li>4. Empty fuel tank and refill tank with fresh, clean gasoline.</li><li>5. Connect wire to plug.</li><li>6. Replace spark plug.</li><li>7. Tighten blade bolt or replace blade adapter.</li><li>8. Depress control bar to handle.</li><li>9. Replace control bar.</li><li>10. Turn fuel valve lever to the ON position.</li><li>11. Charge battery.</li><li>12. Connect battery to engine.</li><li>13. Replace fuse.</li></ol>

**TROUBLESHOOTING - See appropriate section in manual unless directed to a Sears Parts & Repair Centre.**

<b>PROBLEM</b>	<b>CAUSE</b>	<b>CORRECTION</b>
<b>Loss of power</b>	<ol style="list-style-type: none"> <li>1. Rear of lawn mower housing or cutting blade dragging in heavy grass.</li> <li>2. Cutting too much grass.</li> <li>3. Dirty air filter.</li> <li>4. Buildup of grass, leaves, and trash under mower.</li> <li>5. Too much oil in engine.</li> <li>6. Walking speed too fast.</li> </ol>	<ol style="list-style-type: none"> <li>1. Raise cutting height.</li> <li>2. Raise cutting height.</li> <li>3. Clean/replace air filter.</li> <li>4. Clean underside of mower housing.</li> <li>5. Check oil level.</li> <li>6. Cut at slower walking speed.</li> </ol>
<b>Poor cut – uneven</b>	<ol style="list-style-type: none"> <li>1. Worn, bent or loose blade.</li> <li>2. Wheel heights uneven.</li> <li>3. Buildup of grass, leaves and trash under mower.</li> </ol>	<ol style="list-style-type: none"> <li>1. Replace blade. Tighten blade bolt.</li> <li>2. Set all wheels at same height.</li> <li>3. Clean underside of mower housing.</li> </ol>
<b>Excessive vibration</b>	<ol style="list-style-type: none"> <li>1. Worn, bent or loose blade.</li> <li>2. Bent engine crankshaft.</li> </ol>	<ol style="list-style-type: none"> <li>1. Replace blade. Tighten blade bolt.</li> <li>2. Contact a Sears or other qualified service centre.</li> </ol>
<b>Starter rope hard to pull</b>	<ol style="list-style-type: none"> <li>1. Engine flywheel brake is on when control bar is released.</li> <li>2. Bent engine crankshaft.</li> <li>3. Blade adapter broken.</li> <li>4. Blade dragging in grass.</li> </ol>	<ol style="list-style-type: none"> <li>1. Depress control bar to upper handle before pulling starter rope.</li> <li>2. Contact a Sears or other qualified service centre.</li> <li>3. Replace blade adapter.</li> <li>4. Move lawn mower to cut grass or to hard surface.</li> </ol>
<b>Grass catcher not filling (If so equipped)</b>	<ol style="list-style-type: none"> <li>1. Cutting height too low.</li> <li>2. Lift on blade worn off.</li> <li>3. Catcher not venting air.</li> </ol>	<ol style="list-style-type: none"> <li>1. Raise cutting height.</li> <li>2. Replace blade.</li> <li>3. Clean grass catcher.</li> </ol>
<b>Hard to push</b>	<ol style="list-style-type: none"> <li>1. Grass is too high or wheel height is too low.</li> <li>2. Rear of lawn mower housing or cutting blade dragging in grass.</li> <li>3. Grass catcher too full.</li> <li>4. Handle height position not right for you.</li> </ol>	<ol style="list-style-type: none"> <li>1. Raise cutting height.</li> <li>2. Raise rear of lawn mower housing one (1) setting higher.</li> <li>3. Empty grass catcher.</li> <li>4. Adjust handle height to suit.</li> </ol>
<b>Loss of drive or slowing of drive speed</b>	<ol style="list-style-type: none"> <li>1. Belt wear.</li> <li>2. Belt off of pulley.</li> <li>3. Drive cable worn or broken.</li> <li>4. “Loose” drive control system.</li> </ol>	<ol style="list-style-type: none"> <li>1. Check/replace drive belt.</li> <li>2. Check/reinstall drive belt.</li> <li>3. Replace drive cable.</li> <li>4. Adjust drive control.</li> </ol>

# CRAFTSMAN PROFESSIONAL ROTARY LAWN MOWER - - MODEL NUMBER 944.361361

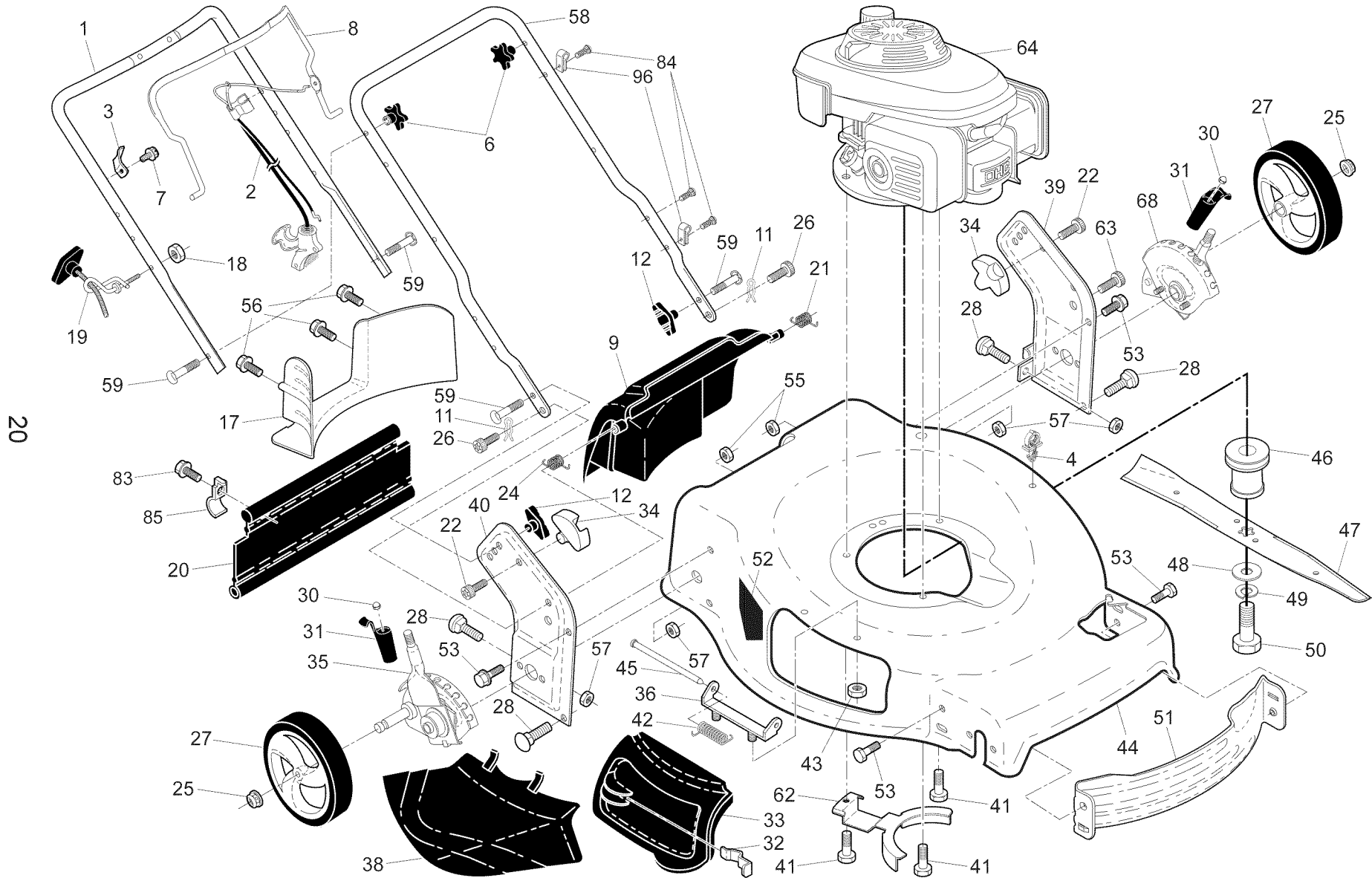

REPAIR PARTS

## CRAFTSMAN PROFESSIONAL ROTARY LAWN MOWER - - MODEL NUMBER 944.361361

KEY NO.	PART NO.	DESCRIPTION	KEY NO.	PART NO.	DESCRIPTION	KEY NO.	PART NO.	DESCRIPTION
1	183471X479	Upper Handle	30	413808	Nut, Push	52	404763	Decal, Danger
2	438391	Cable, Engine Zone Control / Rear Door Prop	31	419407X615	Selector Knob	53	17000510	Screw, Semi-Gimlett Point 1/4-20 x 1/2
3	429930X004	Bracket, Upstop	32	419944X007	Latch, Mulcher Door	55	191730	Nut, Hex
4	145006	Guide, Cable	33	420019	Mulcher Door	56	17411312	Screw, Hex Washer Head #13 x 3/4
5	66426	Wire Tie	34	419946X615	Bracket, Grassbag	57	155377	Nut, Hex
6	182398	Handle Knob, Star	35	431127	Kit, Wheel Adjuster, Rear, RH (Includes Knob & Pushnut)	58	421241X479	Lower Handle
7	750634	Screw #10-24 x 1/2	36	175735	Hinge Bracket Assembly	59	191574	Handle Bolt
8	426432X428	Control Bar	38	419942X428	Discharge Deflector	62	431913X004	Belt Retainer
9	430654	Rear Door Assembly	39	442470X479	Handle Bracket, LH	63	178848	Screw #10-16 x 5/8
11	425575	Hairpin, Door/Handle Pivot	40	438526X479	Handle Bracket, RH	64	- - -	Engine, Honda, Model Number GCV160-LAOS3A (See Breakdown)
12	189713X428	Handle Knob, Standard	41	150406	Bolt, Engine	68	431129	Kit, Wheel Adjust, Rear, LH (Includes Knob & Pushnut)
17	427120X428	Rear Baffle	42	193000	Spring, Torsion	83	750097	Screw
18	132004	Keps Locknut 1/4-20	43	191730	Nut, Hex, Nylock	84	428124	Fastener, Push
19	194788	Rope Guide	44	431558	Kit, Lawn Mower Housing	85	429801X004	Mounting Bracket, Rear Skirt
20	429157	Rear Skirt	45	175650	Rod, Hinge	96	197991	Clip, Cable
21	419949	Spring, Rear Door, LH, Black	46	421782	Blade Adapter / Pulley	--	443307	Owner's Manual, English
22	141841	Screw, Panhead, Torx #20	47	421825	Blade, 22"	--	443308	Owner's Manual, French
24	419948	Spring, Rear Door, RH, Grey	48	851074	Washer, Hardened			
25	409148	Nut, Hex, Flanged	49	850263	Washer, Helical			
26	419945	Screw, Rear Door/Handle Pivot	50	851084	Screw, Machine, Hex Head 3/8-24 x 1-3/8 Grade 8			
27	400246X460	Wheel & Tire Assembly, Rear	51	430599	Front Baffle			
28	72250505	Bolt, Carriage 5/16-18 x 5/8						

**NOTE:** All component dimensions given in U.S. inches. 1 inch = 25.4 mm.

**IMPORTANT:** Use only Original Equipment Manufacturer (O.E.M.) replacement parts. Failure to do so could be hazardous, damage your lawn mower and void your warranty.

**CRAFTSMAN PROFESSIONAL ROTARY LAWN MOWER - - MODEL NUMBER 944.361361**

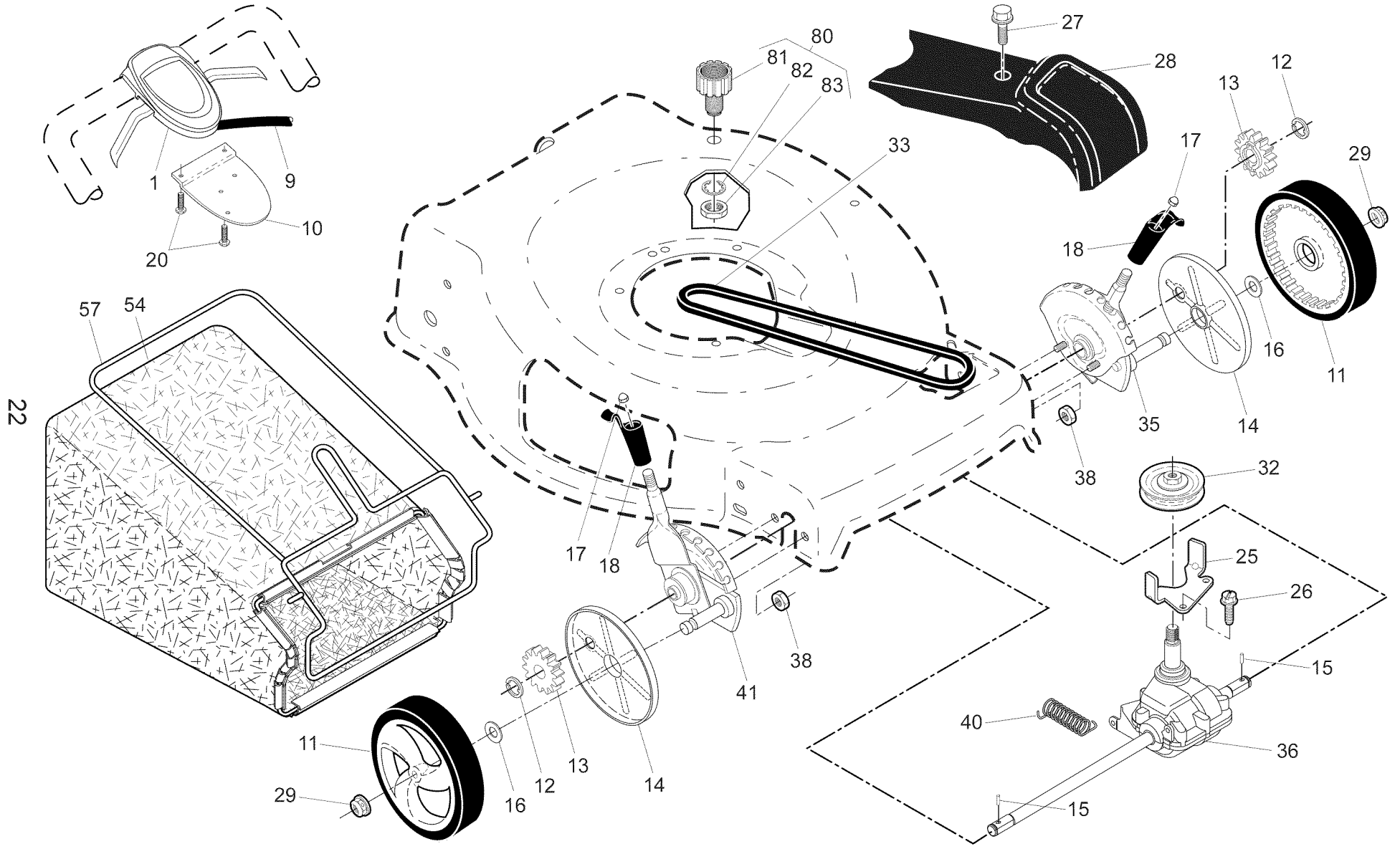

## CRAFTSMAN PROFESSIONAL ROTARY LAWN MOWER - - MODEL NUMBER 944.361361

KEY NO.	PART NO.	DESCRIPTION	KEY NO.	PART NO.	DESCRIPTION
1	431508	Drive Control Assembly (Includes Cable)	28	428165	Drive Cover
9	431649	Cable, Drive	29	409148	Locknut, Hex
10	429544X479	Mounting Bracket, Drive Control	32	194018	Drive Pulley
11	194231X460	Wheel & Tire Assembly	33	426609	V-Belt
12	12000058	E-Ring	35	431124	Kit, Wheel Adjuster, Front, LH (Includes Knob and Pushnut)
13	403849	Pinion	36	424657	Gearcase Assembly, Complete
14	189403	Dust Cover	38	191730	Locknut, Hex 1/4-20
15	404845	Pawl, Drive	40	406558	Spring
16	67725	Washer, Flat 3/8	41	431121	Kit, Wheel Adjuster, Front, RH (Includes Knob and Pushnut)
17	413808	Nut, Push	54	422506	Grassbag
18	419345X615	Selector Knob	57	419951	Frame, Grassbag
20	181698	Screw	80	421114	Kit, Water Washout Assembly (Includes Key Numbers 81 thru 83)
25	430458X004	Belt Guide Bracket	81	419735	Fitting, Water Washout
26	163409	Screw, Hi-Lo Thread #12 x 5/8	82	415585	Washer, Lock, Internal Tooth
27	175262	Screw, Pan Head #10-24 x 2-3/4	83	415586	Locknut, Hex, with O-Ring

**NOTE:** All component dimensions given in U.S. inches. 1 inch = 25.4 mm.

**IMPORTANT:** Use only Original Equipment Manufacturer (O.E.M.) replacement parts. Failure to do so could be hazardous, damage your lawn mower and void your warranty.

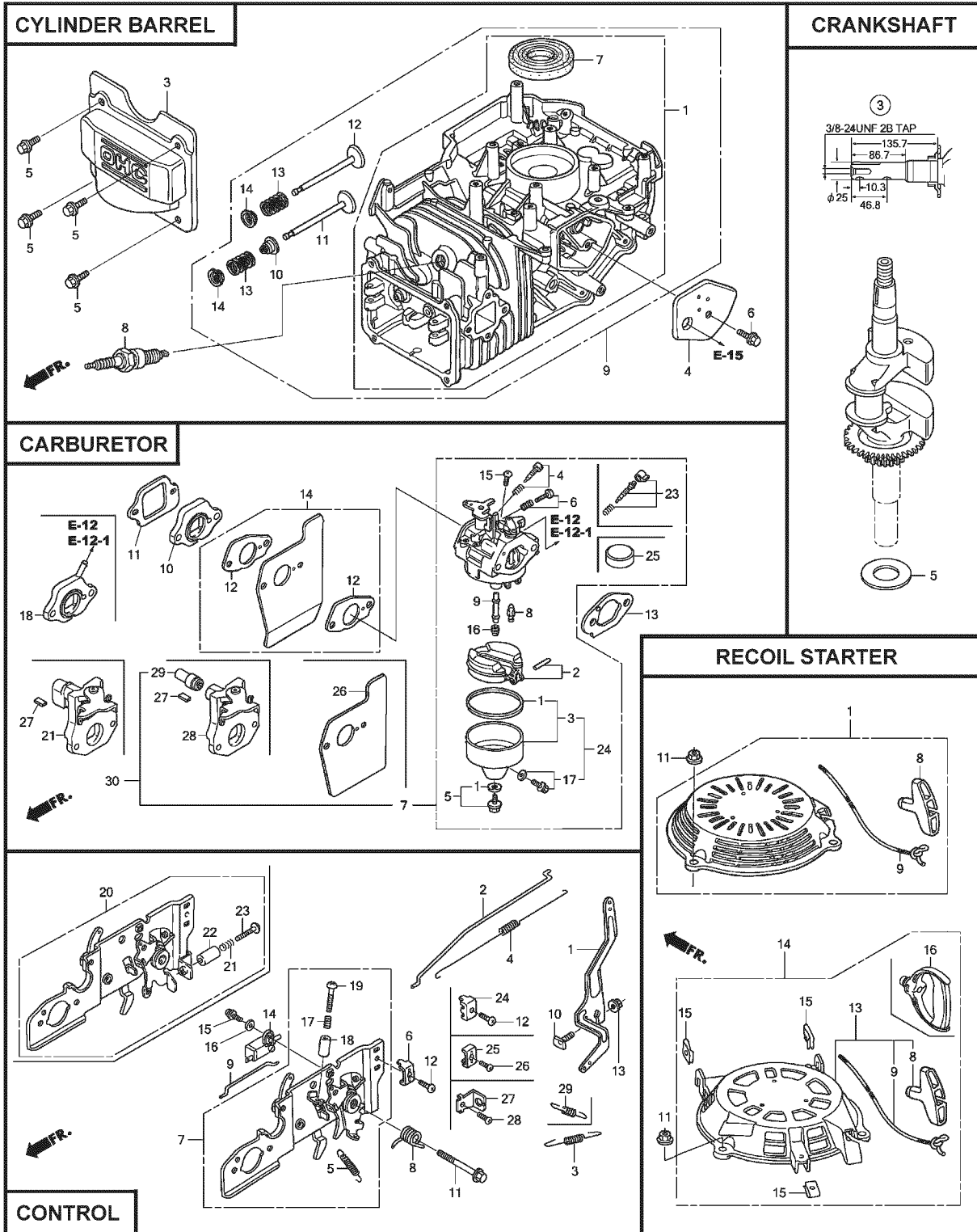



**CYLINDER BARREL****KEY PART**

NO.	NO.	DESCRIPTION
1	12000-Z0L-406	Cylinder Assembly
	12000-Z0L-840	Cylinder Assembly
3	12310-Z0J-000	Cover, Cylinder Head
	12311-ZL8-D00	Cover, Head
	12311-ZL8-000	Cover, Head
4	12355-ZL8-000	Cover, Breather (Breather Valve Assembly)
5	90013-883-000	Bolt, Flange (#6 x 12) (CT200)
6	90014-952-000	Bolt, Flange (#6 x 14) (CT200)
7	91201-ZL8-003	Oil Seal (25.4 x 62 x 6)
8	98079-55846	Spark Plug (BPR5ES) (NGK)
10	12209-ZM0-003	Seal, Valve Stem
11	14711-ZL8-000	Valve, Intake (Technostar)
	14711-Z0J-000	Valve, Intake (Rocknel)
	14711-Z0J-800	Valve, Intake
12	14721-ZL8-000	Valve, Exhaust
13	14751-ZL8-000	Spring, Valve
14	14771-Z0J-000	Retainer, Valve Spring

**CARBURETOR****KEY PART**

NO.	NO.	DESCRIPTION
1	16010-883-015	Gasket Set
2	16013-ZL1-003	Float Set
3	16015-Z0L-881	Chamber Set, Float
5	16028-ZE0-005	Screw Set
	16028-ZK7-S91	Screw Set
7	16100-Z0L-852	Carburetor Assembly (BB62Z B)
8	16155-ZM0-013	Valve, Float
9	16166-ZM0-003	Nozzle, Main
10	16211-ZL8-000	Insulator, Carburetor
11	16212-ZL8-000	Gasket, Insulator
13	16228-ZL8-000	Gasket, Carburetor
15	93500-05006-0H	Screw, Pan (#5 x 6)
16	99101-124-0600	Jet, Main (#60)
	99101-124-0620	Jet, Main (#62)
	99101-124-0650	Jet, Main (#65)
26	16951-Z0L-000	Guide, Air

**CONTROL****KEY PART**

NO.	NO.	DESCRIPTION
1	16551-ZM0-010	Arm, Governor
2	16555-Z0L-801	Rod, Governor
3	16561-Z0L-000	Spring, Governor
4	16562-ZM0-000	Spring, Throttle Return
10	90015-ZE5-010	Bolt, Governor Arm
13	94050-06000	Nut, Flange (6 mm)
15	93892-04012-00	Screw, Washer Head (#4 x 12)
16	94103-04000	Washer, Plain (4 mm)

**CRANKSHAFT****KEY PART**

NO.	NO.	DESCRIPTION
3	13310-ZM0-610	Crankshaft
5	90402-ZL8-000	Washer, Thrust

**RECOIL STARTER****KEY PART**

NO.	NO.	DESCRIPTION
1	28400-Z0L-V20ZA	Starter Assembly, Recoil, "NH1" (Long Rope) (Black)
8	28461-ZL8-003	Grip, Recoil Starter
9	28462-Z0L-V20	Rope, Recoil Starter, "Long Type" (Black)
11	90201-ZM0-000	Nut, Flange (6 mm)

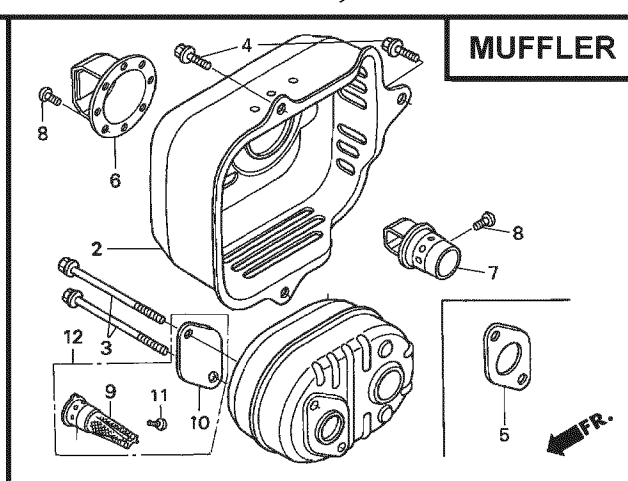
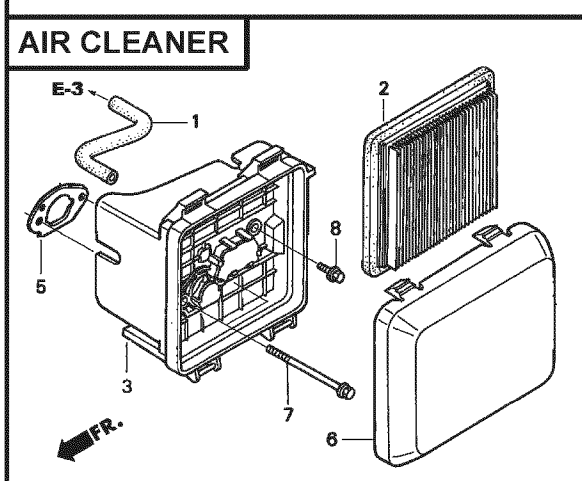
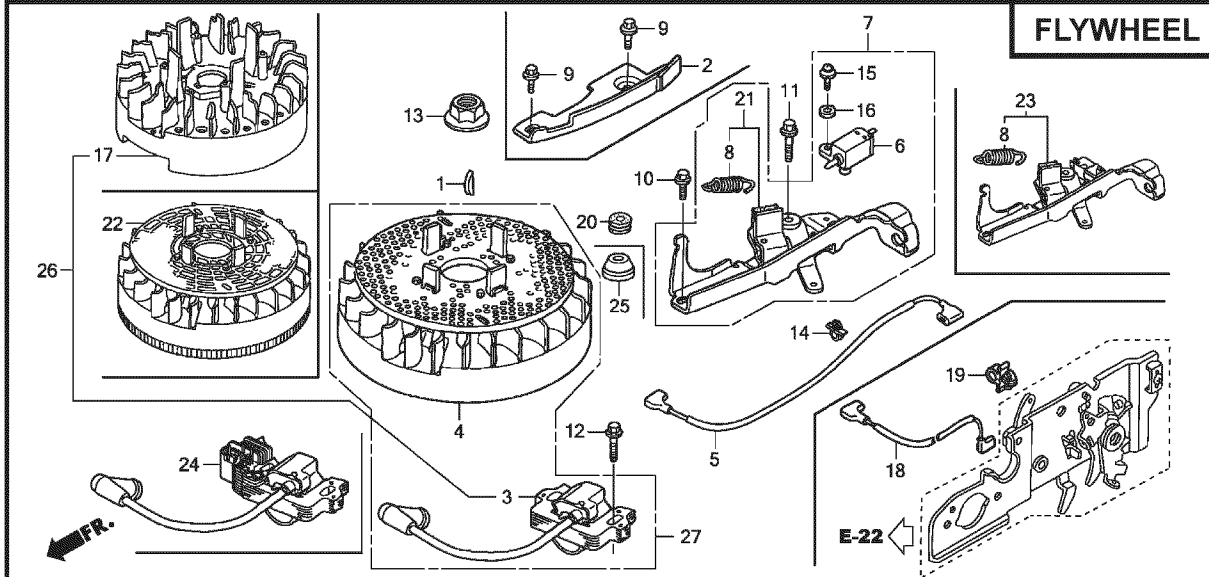
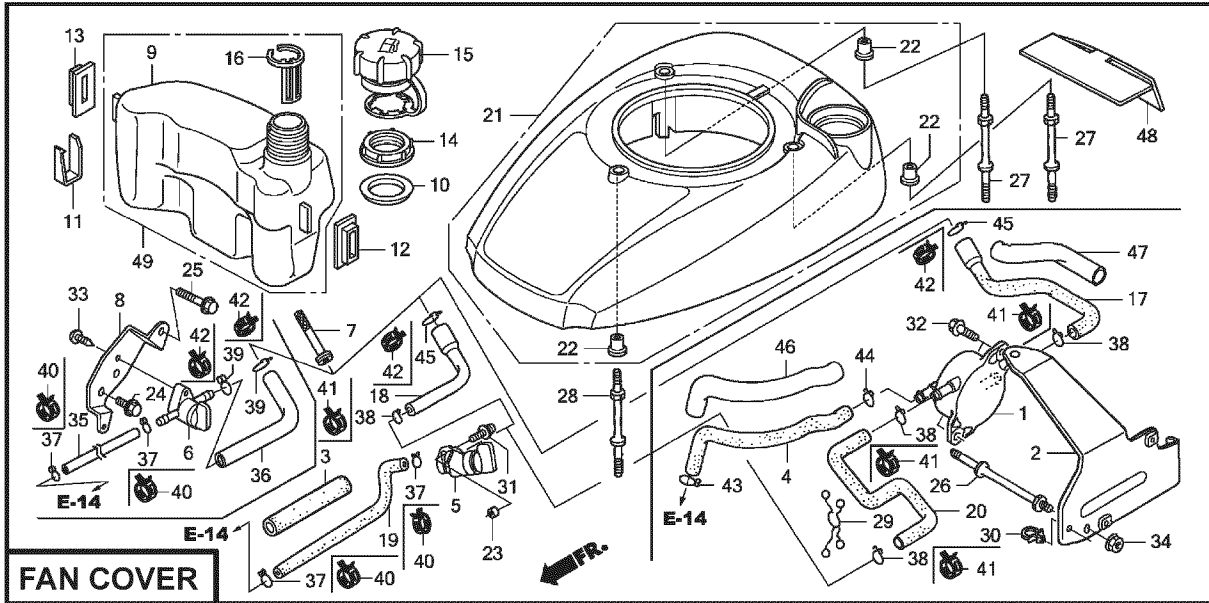

**FAN COVER****KEY PART**

NO.	NO.	DESCRIPTION
6	16950-Z0Y-003	Petcock Assembly
7	16952-ZA8-800	Filter, Fuel
8	16961-Z0L-900	Stay, Fuel Petcock
9	17511-Z0L-030	Tank, Fuel
10	17514-Z0L-000	Seal, Fuel Filler Neck
11	17516-Z0L-000	Clip, Tank Mounting
12	17532-Z0L-000	Rubber A, Tank Mounting
13	17533-Z0L-000	Rubber B, Tank Mounting
14	17534-Z0L-000	Nut, Tank Mounting
15	17620-Z0J-800	Cap Assembly, Fuel Tank
16	17636-Z0L-000	Gauge, Fuel Level
21	19610-Z0L-861ZC	Cover Assembly, Fan "T89" (Craftsman Red)
	19610-Z0L-861ZA	Cover Assembly, Fan "T89" ("NH1") (Black)
	19610-Z0L-861ZD	Cover Assembly, Fan "T93" (Husqvarna Grey)
	19610-Z0L-861ZE	Cover Assembly, Fan "T98" (M.T.D. Red)
22	19619-ZL8-300	Collar, Fan Cover
24	90013-883-000	Bolt, Flanged (#6 x 12) (CT200)
25	90015-883-000	Bolt, Flanged (#6 x 28) (CT200)
27	90043-ZL8-000	Bolt, Stud (H=42.5mm)
28	90043-ZL8-000	Bolt, Stud (H=42.5mm)
33	93913-25220	Screw, Tapping (PO) (#5 x 12)
35	91424-Z8B-821	Tube, Fuel Tank
36	91427-Z8B-821	Tube, Fuel (7.3 x 160)
40	95002-40800-08	Clip, Tube (D8)
42	95002-41200-08	Clip, Tube (D12)

**MUFFLER****KEY PART**

NO.	NO.	DESCRIPTION
1	18310-ZM0-000	Muffler
2	18321-Z0L-J00	Protector, Muffler (S/N 1243452 and below)
	18321-Z0L-J01	Protector, Muffler (S/N 1243453 and above)
3	90004-ZL8-000	Bolt, Flange #6 x 79 (CT200)
4	90013-883-000	Bolt, Flange #6 x 12 (CT200)
5	18381-ZL8-305	Gasket, Muffler
9	18350-ZL8-000	Arrester, Spark
10	18356-ZL8-000	Plate, Arrester Number
11	90055-ZE1-000	Screw, Tapping #4 x 6
12	06180-Z0J-000	Kit, Spark Arrester

**FLYWHEEL****KEY PART**

NO.	NO.	DESCRIPTION
1	13331-357-000	Key, Special, Woodruff (25 x 18)
3	30500-ZL8-014	Coil Assembly, Ignition
4	31105-ZM0-000	Flywheel Assembly
5	32195-ZM0-800	Wire, Stop Switch
6	35120-ZM0-003	Switch Assembly, Engine Stop (NC)
8	75113-ZM0-000	Spring, Brake Lever
10	90014-952-000	Bolt, Flange (#6 x 14) (CT200)
11	90018-ZE1-000	Bolt, Flange (#6 x 23) (CT200)
12	90018-ZE1-000	Bolt, Flange (#6 x 23) (CT200)
13	90201-Z0T-800	Nut, Special (14 mm)
14	51125-Z0L-003	Holder, Wire (Fastex)
	90681-959-003	Clip A, Cable (3.8mm) (Black) (NIFCO)
15	93892-04012-00	Screw, Washer Head (#4 x 12)
16	94103-04000	Washer, Plain (4 mm)
21	75110-Z0Y-000	Brake Sub Assembly
25	91601-Z0L-300	Grommet, Brake Plate

**AIR CLEANER****KEY PART**

NO.	NO.	DESCRIPTION
1	15721-ZM0-000	Tube, Breather
2	17211-ZL8-023	Element, Air Cleaner
3	17220-ZM0-010	Case Assy., Air Cleaner (S/N 1167575 and below)
	17220-ZM0-020	Case Assy., Air Cleaner (S/N 1167576-1239013)
	17220-ZM0-030	Case Assy., Air Cleaner (S/N 1239014 and above)
5	17228-ZM0-000	Gasket, Air Cleaner
6	17231-Z0L-030	Cover, Air Cleaner (S/N 1167575 and below)
	17231-Z0L-040	Cover, Air Cleaner (S/N 1167575 and below)
	17231-Z0L-050	Cover, Air Cleaner
7	90003-ZM0-010	Bolt, Flange (#6 x 85) (CT200)

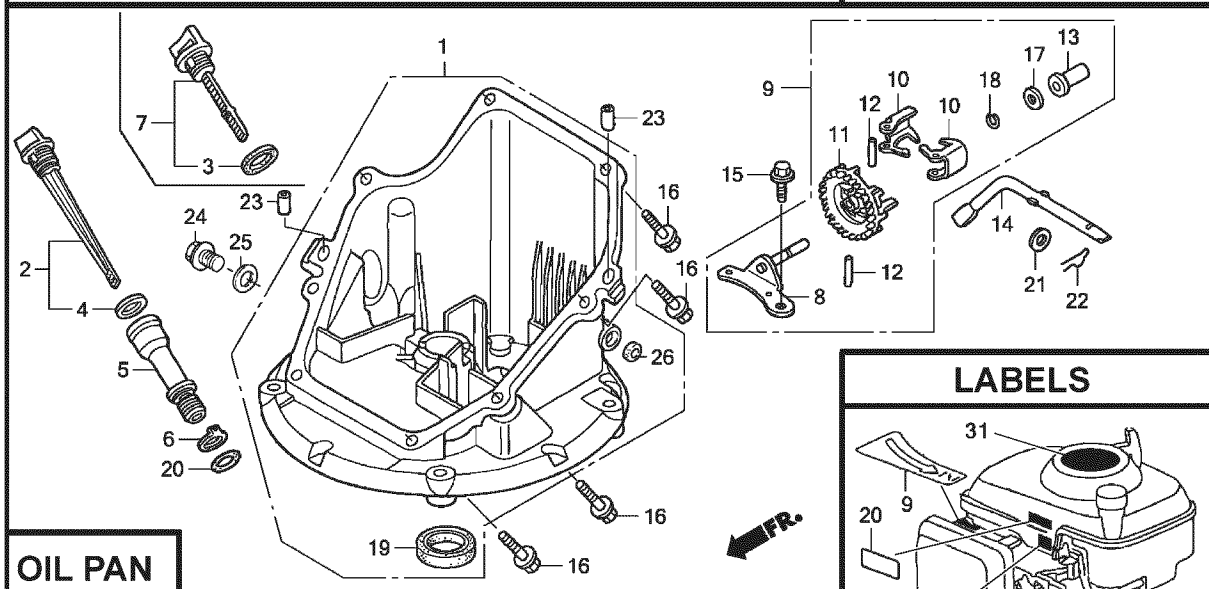
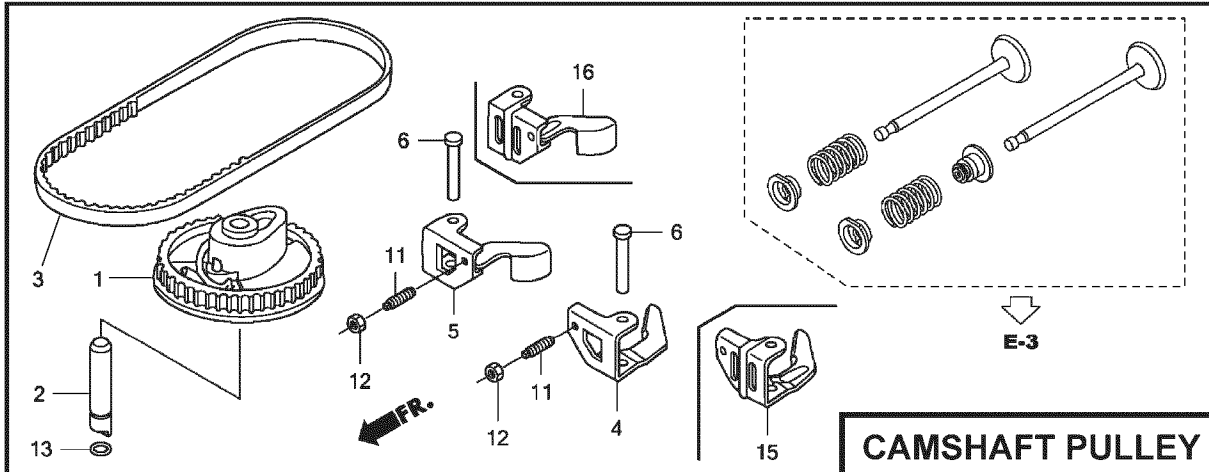

**PISTON AND CONNECTING ROD**

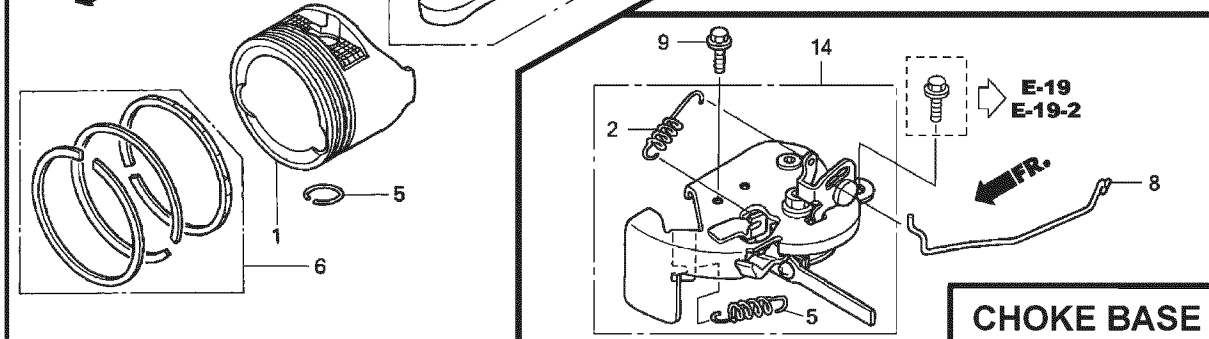
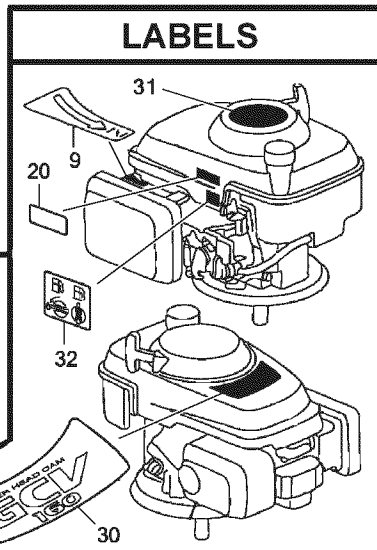
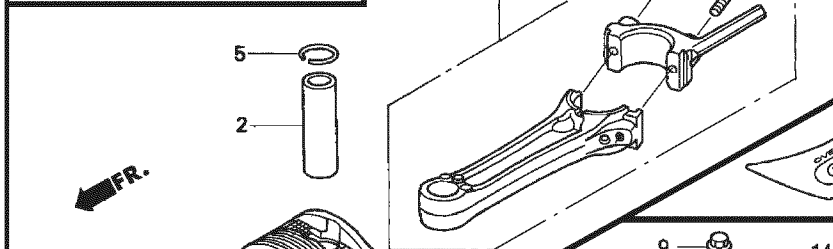

**CAMSHAFT PULLEY****KEY PART**

NO.	NO.	DESCRIPTION
1	14320-ZL8-010	Pulley, Camshaft
2	14324-ZL8-000	Shaft, Cam Pulley
3	14400-Z0J-014	Belt, Timing (84HU7 G-200)
6	14461-ZL8-000	Shaft, Rocker Arm
11	90112-333-000	Screw, Tappet Adjusting
12	90206-001-000	Nut, Tappet Adjusting
13	91301-ZM0-V31	O-Ring (6.8 x 1.9) (ARAI)
15	14431-Z0J-000	Rocker Arm, Intake Valve
16	14441-Z0J-000	Rocker Arm, Exhaust Valve

**OIL PAN****KEY PART**

NO.	NO.	DESCRIPTION
1	11300-ZM0-811	Pan Assembly, Oil
2	15650-ZM0-801	Gauge Assembly, Oil Level
4	15625-ZE6-000	Gasket, Oil Filler Cap
5	15631-ZM0-000	Extension, Oil Filler
6	15639-ZM0-000	Lock Washer, Extension
8	16508-ZM0-010	Shaft, Governor Holder
9	16510-ZM0-010	Governor Assembly
10	16511-ZL8-000	Weight, Governor
11	16512-ZM0-000	Holder, Governor Weight
12	16513-ZE1-000	Pin, Governor Weight
13	16531-ZE1-000	Slider, Governor
14	16541-ZM0-000	Shaft, Governor Arm
15	90014-952-000	Bolt, Flange (#6 x 14) (CT200)
16	90121-952-000	Bolt, Flange (#6 x 25) (CT200)
17	90451-ZE1-000	Washer, Thrust (6 mm)
18	90602-ZE1-000	Clip, Governor Holder
19	91202-ZL8-003	Oil Seal (28 x 41.25 x 6)
20	91356-MA6-005	O-Ring (14.8 x 2.4) (NOK)
21	94101-068000	Washer, Plain (6 mm)
22	94251-08000	Pin, Lock (8 mm)
23	94301-08200	Pin, Dowel (#8 x 20)

**PISTON / CONNECTING ROD****KEY PART**

NO.	NO.	DESCRIPTION
1	13101-Z2A-010	Piston
2	13111-ZE0-000	Pin, Piston
3	13200-Z0J-000	Connecting Rod Assembly
4	90001-ZE1-000	Bolt, Connecting Rod
5	90551-ZE0-000	Clip, Piston Pin (13 mm)
6	13010-Z0L-014	Ring Set, Piston, Standard (Teikoku)

**LABELS****KEY PART**

NO.	NO.	DESCRIPTION
9	87528-Z0L-V20	Mark, Choke Indication
20	87114-ZH7-821	Label, Warning
30	87101-Z8B-000	Mark, Emblem (GCV160)
31	87169-Z8E-000	Mark, Recoil Cover
32	87524-Z8B-000	Mark, Caution, Fuel Petcock

**CHOKE BASE****KEY PART**

NO.	NO.	DESCRIPTION
2	16592-Z2D-800	Spring, Return
5	16614-Z2D-800	Spring, Choke Lever
8	16632-Z0L-801	Rod, Stop
9	90022-888-010	Bolt, Flange (#6 x 20) (CT200)
14	16610-Z2D-801	Lever Assembly, Choke
	16610-Z2D-802	Lever Assembly, Choke

**SERVICE NOTES**

# **SERVICE NOTES**

# Get it fixed, at your home or ours!

Just Call:

**1-800-4-MY-HOME®**

(1-800-469-4663)

24 hours a day, 7 days a week

For the repair of major brand appliances **in your own home...**  
no matter who made it, no matter who sold it!

For your nearest **Sears Parts and Service** location,  
to bring in products like vacuums, lawn equipment and electronics.

For **Sears Parts & Service**, to order the replacement parts,  
accessories and owner's manuals that you need to do-it-yourself.

[www.sears.ca](http://www.sears.ca)

---

To purchase or inquire about a Sears Maintenance Agreement, call:

**1-800-361-6665**

9 a.m. – 11 p.m. Mon. – Fri., EST, 9 a.m. – 4 p.m. Sat.

---

Pour service en français:

**1-800-LE-FOYER<sup>MC</sup>**

(1-800-533-6937)

[www.sears.ca](http://www.sears.ca)



® / <sup>TM</sup> Trademarks of Sears, Roebuck and Co. used under license by Sears Canada

<sup>MD</sup> Marque déposée / <sup>MC</sup> Marque de commerce de Sears, Roebuck and Co. utilisée en vertu d'une licence de Sears Canada



## Free Manuals Download Website

<http://myh66.com>

<http://usermanuals.us>

<http://www.somanuals.com>

<http://www.4manuals.cc>

<http://www.manual-lib.com>

<http://www.404manual.com>

<http://www.luxmanual.com>

<http://aubethermostatmanual.com>

Golf course search by state

<http://golfingnear.com>

Email search by domain

<http://emailbydomain.com>

Auto manuals search

<http://auto.somanuals.com>

TV manuals search

<http://tv.somanuals.com>