

Owner's Manual

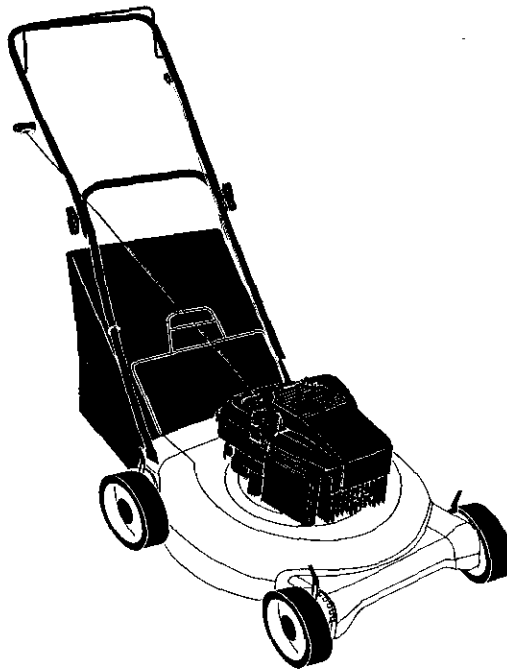

**6.0 HORSEPOWER
21" REAR DISCHARGE
ROTARY LAWN MOWER**

Model No.
944.361530



- **Safety**
- **Assembly**
- **Operation**
- **Maintenance**
- **Repair Parts**

The D.O.M. decal includes engine life specifications for the emissions-related useful life period of your engine. This period relates to the emission compliance life as certified by EPA/CARB. To find the life period specification for your engine, please match one of the following letters with the letter printed on your D.O.M. decal: (C) 125 hours, (B) 250 hours, (A) 500 hours.

CAUTION:

Read and follow all
Safety Rules and Instructions
before operating this equipment

Sears Canada, Inc., Toronto, Ontario M5B 2B8

TABLE OF CONTENTS

Warranty	2	Product Specifications	10
Safety Rules	2-4	Service and Adjustments	12
Assembly	4-5	Storage	13-14
Operation	6-8	Troubleshooting	14-15
Maintenance Schedule	9	Repair Parts	16-23
Maintenance	9-12	Parts Ordering	Back Cover

WARRANTY

LIMITED TWO YEAR WARRANTY ON CRAFTSMAN POWER MOWER

For Two years from date of purchase Sears Canada, Inc. will repair or replace at Sears option free of charge parts which are defective as a result of material or workmanship.

COMMERCIAL OR RENTAL USE:

Warranty on Power Mower (Gas) will be ninety (90) days from date of purchase if used for commercial or rental purposes.

This Warranty does NOT cover:

- Pre-delivery set-up.
- Expendable items which become worn during normal use, such as rotary mower blades, blade adapters, belts, air cleaners and spark plug.
- Repairs necessary because of operator abuse or negligence, including bent crankshafts and the failure to maintain the equipment according to the instructions contained in the owner's manual.

Warranty service is available by returning the Craftsman Power Mower to the nearest Sears Service Centre/Department in Canada. This warranty applies only while this product is in use in Canada.

This warranty is in addition to any statutory warranty and does not exclude or limit legal rights you may have but shall run concurrently with applicable provincial legislation. Furthermore, some provinces do NOT allow limitation on how long an implied warranty will last so the above limitations may not apply to you.

SEARS CANADA, INC., TORONTO, ONTARIO M5B 2B8

SAFETY RULES

IMPORTANT: This cutting machine is capable of amputating hands and feet and throwing objects. Failure to observe the following safety instructions could result in serious injury or death.

I. GENERAL OPERATION

- Read, understand, and follow all instructions on the machine and in the manual(s) before starting. Be thoroughly familiar with the controls and the proper use of the machine before starting.
- Do not put hands or feet near or under rotating parts. Keep clear of the discharge opening at all times.
- Only allow responsible individuals, who are familiar with the instructions, to operate the machine.
- Clear the area of objects such as rocks, toys, wire, bones, sticks, etc., which could be picked up and thrown by the blade.
- Be sure the area is clear of other people before mowing. Stop machine if anyone enters the area.
- Do not operate the mower when barefoot or wearing open sandals. Always wear substantial foot wear.
- Do not pull mower backwards unless absolutely necessary. Always look down and behind before and while moving backwards.
- Do not operate the mower without proper guards, plates, grass catcher or other safety protective devices in place.
- See manufacturer's instructions for proper operation and installation of accessories. Only use accessories approved by the manufacturer.
- Stop the blade(s) when crossing gravel drives, walks, or roads.
- Stop the engine (motor) whenever you leave the equipment, before cleaning the mower or unclogging the chute.

- Shut the engine (motor) off and wait until the blade comes to complete stop before removing grass catcher.
- Mow only in daylight or good artificial light.
- Do not operate the machine while under the influence of alcohol or drugs.
- Never operate machine in wet grass. Always be sure of your footing: keep a firm hold on the handle and walk; never run.
- Disengage the self-propelled mechanism or drive clutch on mowers so equipped before starting the engine (motor).
- If the equipment should start to vibrate abnormally, stop the engine (motor) and check immediately for the cause. Vibration is generally a warning of trouble.
- Always wear safety goggles or safety glasses with side shields when operating mower.

II. SLOPE OPERATION

Slopes are a major factor related to slip and fall accidents which can result in severe injury. All slopes require extra caution. If you feel uneasy on a slope, do not mow it.

DO:

- Mow across the face of slopes: never up and down. Exercise extreme caution when changing direction on slopes.
- Remove obstacles such as rocks, tree limbs, etc.
- Watch for holes, ruts, or bumps. Tall grass can hide obstacles.

DO NOT:

- Do not trim near drop-offs, ditches or embankments. The operator could lose footing or balance.
- Do not trim excessively steep slopes.
- Do not mow on wet grass. Reduced footing could cause slipping.

III. CHILDREN

Tragic accidents can occur if the operator is not alert to the presence of children. Children are often attracted to the machine and the mowing activity. *Never* assume that children will remain where you last saw them.

- Keep children out of the trimming area and under the watchful care of another responsible adult.
- Be alert and turn machine off if children enter the area.

- Before and while walking backwards, look behind and *down* for small children.
- Never allow children to operate the machine.
- Use extra care when approaching blind corners, shrubs, trees, or other objects that may obscure vision.

IV. SERVICES

- Use extra care in handling gasoline and other fuels. They are flammable and vapors are explosive.
 - Use only an approved container.
 - Never remove gas cap or add fuel with the engine running. Allow engine to cool before refueling. Do not smoke.
 - Never refuel the machine indoors.
 - Never store the machine or fuel container inside where there is an open flame, such as a water heater.
- Never run a machine inside a closed area.
- Never make adjustments or repairs with the engine (motor) running. Disconnect the spark plug wire, and keep the wire away from the plug to prevent accidental starting.
- Keep nuts and bolts, especially blade attachment bolts, tight and keep equipment in good condition.
- Never tamper with safety devices. Check their proper operation regularly.
- Keep machine free of grass, leaves, or other debris build-up. Clean oil or fuel spillage. Allow machine to cool before storing.
- Stop and inspect the equipment if you strike an object. Repair, if necessary, before restarting.
- Never attempt to make wheel height adjustments while the engine (motor) is running.
- Grass catcher components are subject to wear, damage, and deterioration, which could expose moving parts or allow objects to be thrown. Frequently check components and replace with manufacturer's recommended parts, when necessary.
- Mower blades are sharp and can cut. Wrap the blade(s) or wear gloves, and use extra caution when servicing them.
- Do not change the engine governor setting or overspeed the engine.

⚠ Look for this symbol to point out important safety precautions. It means **CAUTION!!! BECOME ALERT!!! YOUR SAFETY IS INVOLVED.**



⚠ **CAUTION:** Muffler and other engine parts become extremely hot during operation and remain hot after engine has stopped. To avoid severe burns on contact, stay away from these areas.

⚠ **CAUTION:** Always disconnect spark plug wire and place wire where it cannot contact spark plug in order to prevent accidental starting when setting up, transporting, adjusting or making repairs.

ASSEMBLY

Read these instructions and this manual in its entirety before you attempt to assemble or operate your new lawn mower.

IMPORTANT: This lawn mower is shipped **WITHOUT OIL OR GASOLINE** in the engine.

Your new lawn mower has been assembled at the factory with the exception of those parts left unassembled for shipping purposes. All parts such as nuts, washers, bolts, etc., necessary to complete the assembly have been placed in the parts bag. To ensure safe and proper operation of your lawn mower, all parts and hardware you assemble must be tightened securely. Use the correct tools as necessary to ensure proper tightness.

TO REMOVE LAWN MOWER FROM CARTON

1. Remove loose parts included with mower.
2. Cut down two end corners of carton and lay end panel down flat.
3. Remove all packing materials except padding between upper and lower handle and padding holding operator presence control bar to upper handle.
4. Roll lawn mower out of carton and check carton thoroughly for additional loose parts.

HOW TO SET UP YOUR LAWN MOWER

TO UNFOLD HANDLE

IMPORTANT: Unfold handle carefully so as not to pinch or damage control cables.

1. Raise handles until lower handle section locks into place in mowing position.
2. Remove protective padding, raise upper handle section into place on lower handle and tighten both handle knobs.
3. Remove handle padding holding operator presence control bar to upper handle.

Your lawn mower handle can be adjusted for your mowing comfort. Refer to "Adjust Handle" in the Service and Adjustments section of this manual.

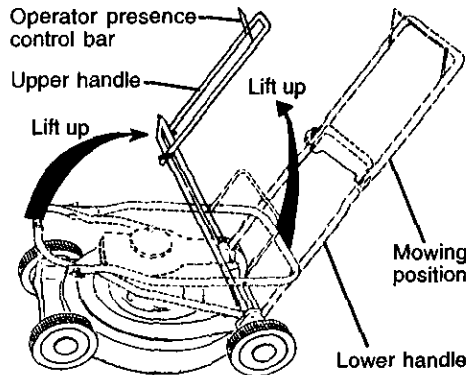

TO ASSEMBLE GRASS CATCHER

1. Put grass catcher frame into grass bag with rigid part of bag on the bottom. Make sure the frame handle is outside of the bag top.
2. Slip vinyl bindings over frame.

NOTE: If vinyl bindings are too stiff, hold them in warm water for a few minutes. If bag gets wet, let it dry before using.

CAUTION: Do not run your lawn mower without clipping deflector or approved grass catcher in place. Never attempt to operate the lawn mower with the rear door removed or propped open.

TO INSTALL ATTACHMENTS

Your lawn mower was shipped ready to be used as a mulcher. To convert to bagging or discharging, see "TO CONVERT MOWER" in the OPERATION section of this manual.

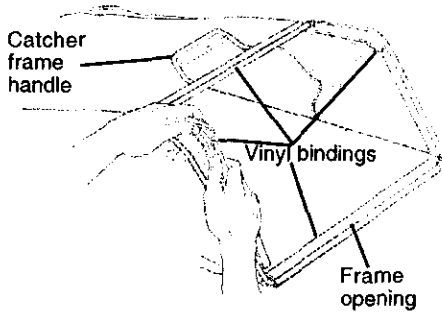

OPERATION

KNOW YOUR LAWN MOWER

READ THIS OWNER'S MANUAL AND SAFETY RULES BEFORE OPERATING YOUR LAWN MOWER. Compare the illustrations with your lawn mower to familiarize yourself with the location of various controls and adjustments. Save this manual for future reference.

These symbols may appear on your lawn mower or in literature supplied with the product. Learn and understand their meaning.

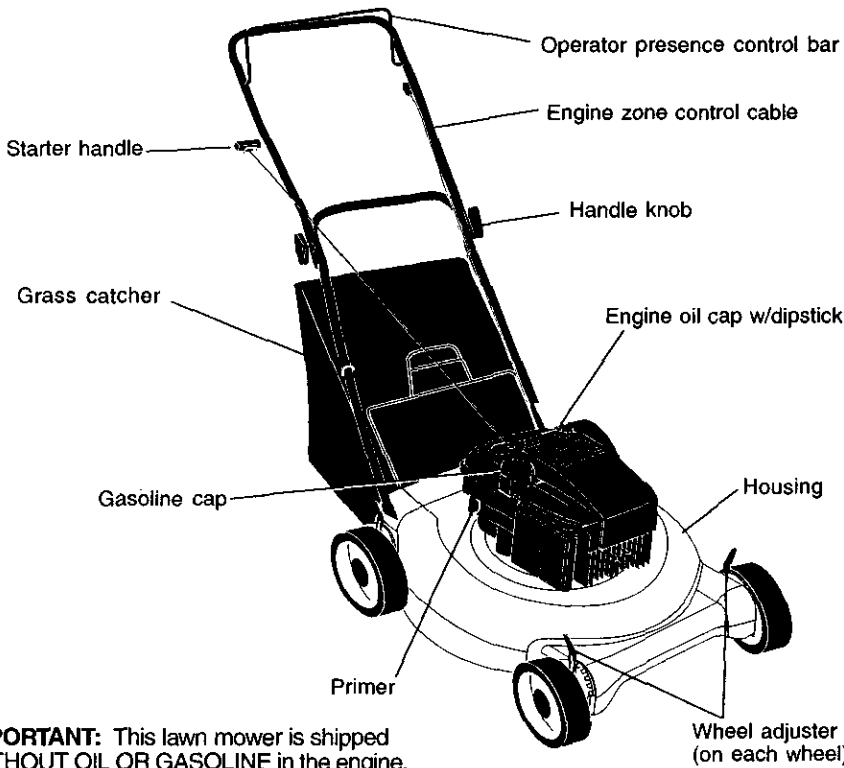
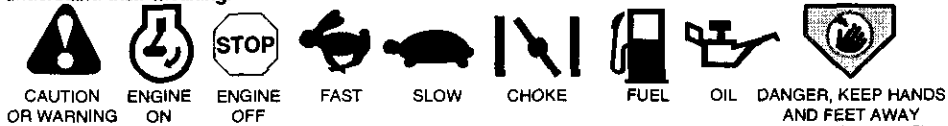

IMPORTANT: This lawn mower is shipped WITHOUT OIL OR GASOLINE in the engine.

MEETS CPSC SAFETY REQUIREMENTS

Sears rotary walk-behind power lawn mowers conform to the safety standards of the American National Standards Institute and the U.S. Consumer Product Safety Commission. The blade turns when the engine is running.

Operator presence control bar - must be held down to the handle to start the engine. Release to stop the engine.

Primer - pumps additional fuel from the carburetor to the cylinder for use when starting a cold engine.
Starter handle - used for starting the engine.



The operation of any lawn mower can result in foreign objects thrown into the eyes, which can result in severe eye damage. Always wear safety glasses or eye shields while operating your lawn mower or performing any adjustments or repairs. We recommend a wide vision safety mask over spectacles or standard safety glasses.

HOW TO USE YOUR LAWN MOWER ENGINE SPEED

The engine speed was set at the factory for optimum performance. Speed is not adjustable.

ENGINE ZONE CONTROL

CAUTION: Federal regulations require an engine control to be installed on this lawn mower in order to minimize the risk of blade contact injury. Do not under any circumstances attempt to defeat the function of the operator control. The blade turns when the engine is running.

- Your lawn mower is equipped with an operator presence control bar which requires the operator to be positioned behind the lawn mower handle to start and operate the lawn mower.

TO ADJUST CUTTING HEIGHT

Raise wheels for low cut and lower wheels for high cut. Adjust cutting height to suit your requirements. Medium position is best for most lawns.

- To change cutting height, squeeze adjuster lever toward wheel. Move wheel up or down to suit your requirements. Be sure all wheels are in the same setting.

NOTE: Adjuster is properly positioned when plate tab inserts into hole in lever. Also, 9-position adjusters (if so equipped) allow lever to be positioned between the plate tabs.

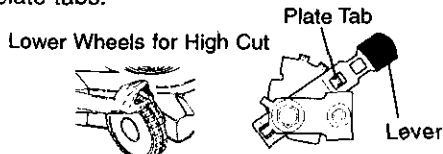

Raise Wheels for Low Cut

TO CONVERT MOWER

Your lawn mower was shipped ready to be used as a mulcher. To convert to bagging:

REAR BAGGING

- Lift rear door of the lawn mower and place the grass catcher frame hooks onto the door pivot pins.

- To convert to mulching operation, remove grass catcher and close rear door.

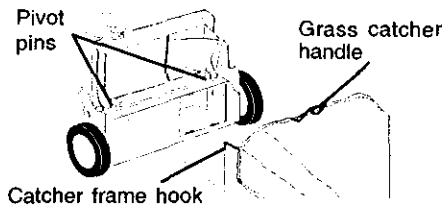

BEFORE STARTING ENGINE

ADD OIL

Your lawnmower is shipped without oil in the engine. Engine holds 20 oz. of oil. For type and grade of oil to use, see "ENGINE" in Maintenance section of this manual.

- Be sure lawnmower is level and area around oil fill is clean.
- Remove engine oil cap and fill to the full line on the dipstick. Pour oil slowly. Do not over fill.

NOTE: Allow oil to settle down into engine for accurate reading. To read proper level, tighten engine oil cap, then remove it to read the dipstick.

- Reinstall engine oil cap and tighten.
 - Check oil level before each use. Add oil if needed. Fill to full line on dipstick.
 - Change the oil after every 25 hours of operation or each season. You may need to change the oil more often under dusty, dirty conditions.

ADD GASOLINE

NOTE: Before filling fuel tank, remove and discard the debris plug that is inside the tank.

- Fill fuel tank. Use fresh, clean, regular unleaded gasoline with a minimum of 87 octane. Do not mix oil with gasoline. Purchase fuel in quantities that can be used within 30 days to assure fuel freshness.

WARNING: Experience indicates that alcohol blended fuels (called gasohol or using ethanol or methanol) can attract moisture which leads to separation and formation of acids during storage. Acidic gas can damage the fuel system of an engine while in storage. To avoid engine problems, the fuel system should be emptied before storage of 30 days or longer. Drain the gas tank, start the engine and let it run until the fuel lines and carburetor are empty. Use fresh fuel next season. See Storage Instructions for additional information. Never use engine or carburetor cleaner products in the fuel tank or permanent damage may occur.

CAUTION: Fill to bottom of gas tank filler neck. Do not overfill. Wipe off any spilled oil or fuel. Do not store, spill or use gasoline near an open flame.

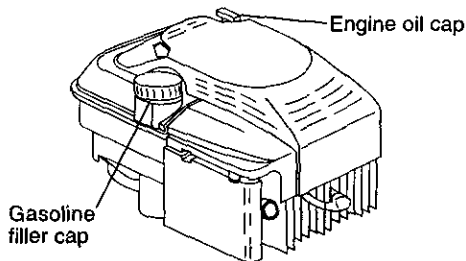

TO START ENGINE

NOTE: Due to protective coatings on the engine, a small amount of smoke may be present during the initial use of the product and should be considered normal.

1. To start a cold engine, push primer three (3) times before trying to start. Use a firm push. This step is not usually necessary when starting an engine which has already run for a few minutes.
2. Hold operator presence control bar down to the handle and pull starter handle quickly. Do not allow starter rope to snap back.

TO STOP ENGINE

- To stop engine, release operator presence control bar.

NOTE: In cooler weather it may be necessary to repeat priming steps. In warmer weather over priming may cause flooding and engine will not start. If you do flood engine, wait a few minutes before attempting to start and do not repeat priming steps.

MOWING TIPS

- Under certain conditions, such as very tall grass, it may be necessary to raise the height of cut to reduce pushing effort and to keep from overloading the engine and leaving clumps of grass clippings. It may also be necessary to reduce ground speed and/or run the lawn mower over the area a second time.
- For extremely heavy cutting, reduce the width of cut by overlapping previously cut path and mow slowly.
- For better grass bagging and most cutting conditions, the engine speed should be set in the fast position.

- Pores in cloth grass catchers can become filled with dirt and dust with use and catchers will collect less grass. To prevent this, regularly hose catcher off with water and let dry before using.
- Keep top of engine around starter clear and clean of grass clippings and chaff. This will help engine air flow and extend engine life.

MULCHING MOWING TIPS

IMPORTANT: For best performance, keep mower housing free of built-up grass and trash. See "Cleaning" in Maintenance section of this manual.

- The special mulching blade will recut the grass clippings many times and reduce them in size so that as they fall onto the lawn they will disperse into the grass and not be noticed. Also, the mulched grass will biodegrade quickly to provide nutrients for the lawn. Always mulch with your highest engine (blade) speed as this will provide the best recutting action of the blades.
- Avoid cutting your lawn when it is wet. Wet grass tends to form clumps and interferes with the mulching action. The best time to mow your lawn is the early afternoon. At this time the grass has dried and the newly cut area will not be exposed to the direct sun.
- For best results, adjust the lawn mower cutting height so that the lawn mower cuts off only the top one-third of the grass blades. If the lawn is overgrown it will be necessary to raise the height of cut to reduce pushing effort and to keep from overloading the engine and leaving clumps of mulched grass. For extremely heavy mulching, reduce your width of cut by overlapping previously cut path and mow slowly.
- Certain types of grass and grass conditions may require that an area be mulched a second time to completely hide the clippings. When doing a second cut, mow across or perpendicular to the first cut path.
- Change your cutting pattern from week to week. Mow north to south one week then change to east to west the next week. This will help prevent matting and graining of the lawn.

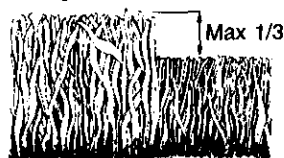

MAINTENANCE

MAINTENANCE SCHEDULE		SERVICE DATES				
FILL IN DATES AS YOU COMPLETE REGULAR SERVICE		BEFORE EACH USE	AFTER EACH USE	EVERY 10 HOURS	EVERY 25 HOURS OR EVERY SEASON	BEFORE STORAGE
M O W E R	Check for Loose Fasteners	✓			✓	
	Clean/Inspect Grass Catcher (If Equipped)	✓	✓		✓	
	Clean Lawn Mower		✓		✓	
	Clean Under Drive Cover (Power-Propelled Mowers)			✓		
	Check drive belt/pulleys (Power-Propelled Mowers)			✓		
	Check/Sharpen/Replace Blade			✓ ₃		
	Lubrication Chart			✓	✓	
	Clean Battery/Recharge (Electric Start Mowers)			✓	✓ ₄	
E N G I N E	Check Engine Oil Level	✓				
	Change Engine Oil			✓ _{1,2}		
	Clean Air Filter			✓ ₂		
	Inspect Muffler			✓		
	Clean or Replace Spark Plug			✓		
Replace Air Filter Paper Cartridge			✓ ₂			

- 1 - Change more often when operating under a heavy load or in high ambient temperatures.
- 2 - Service more often when operating in dirty or dusty conditions.
- 3 - Replace blades more often when mowing in sandy soil.
- 4 - Charge 48 hours at end of season.

GENERAL RECOMMENDATIONS

The warranty on this lawn mower does not cover items that have been subjected to operator abuse or negligence. To receive full value from the warranty, operator must maintain mower as instructed in this manual. Some adjustments will need to be made periodically to properly maintain your unit.

All adjustments in the Service and Adjustments section of this manual should be checked at least once each season.

- Once a year, replace the spark plug, replace air filter element and check blade for wear. A new spark plug and clean/new air filter element assures proper air-fuel mixture and helps your engine run better and last longer.
- Follow the maintenance schedule in this manual.

BEFORE EACH USE

1. Check engine oil level.
2. Check for loose fasteners.

LUBRICATION

Keep unit well lubricated (See "LUBRICATION CHART").

LUBRICATION CHART

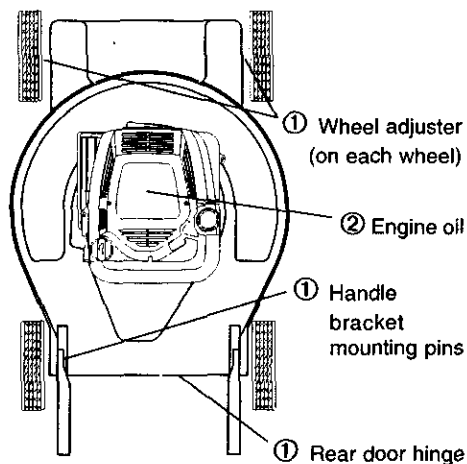

① Spray lubricant

② Refer to Maintenance "ENGINE" section.

IMPORTANT: Do not oil or grease plastic wheel bearings. Viscous lubricants will attract dust and dirt that will shorten the life of the self lubricating bearings. If you feel they must be lubricated, use only a dry, powdered graphite type lubricant sparingly.

PRODUCT SPECIFICATIONS

SÉRIAL NUMBER	
DATE OF PURCHASE	
GASOLINE CAPACITY/TYPE:	1.6 QUARTS UNLEADED REGULAR
OIL TYPE (API-SF-SJ):	SAE 30 (ABOVE 32°F) SAE 5W-30 (BELOW 32°F)
OIL CAPACITY:	20 OZS.
SPARK PLUG (GAP: .030")	CHAMPION RESISTOR TYPE RJ19LM
BLADE BOLT TORQUE:	35-40 FT. LBS.
<ul style="list-style-type: none"> The model and serial numbers will be found on a decal on the rear of the lawn mower housing. Record serial number & date of purchase in space provided above. 	

LAWN MOWER

Always observe safety rules when performing any maintenance.

TIRES

- Keep tires free of gasoline, oil, or insect control chemicals which can harm rubber.
- Avoid stumps, stones, deep ruts, sharp objects and other hazards that may cause tire damage.

BLADE CARE

For best results, mower blade must be kept sharp. Replace bent or damaged blades.

TO REMOVE BLADE

1. Disconnect spark plug wire from spark plug and place wire where it cannot come in contact with spark plug.
2. Turn lawn mower on its side. Make sure air filter and carburetor are up.
3. Use a wood block between blade and mower housing to prevent blade from turning when removing blade bolt.

NOTE: Protect your hands with gloves and/or wrap blade with heavy cloth.

4. Remove blade bolt by turning counter-clockwise.
5. Remove blade and attaching hardware (bolt, lock washer and hardened washer).

NOTE: Remove the blade adapter and check the key inside hub of blade adapter. The key must be in good condition to work properly. Replace adapter if damaged.

TO REPLACE BLADE

1. Position the blade adapter on the engine crankshaft. Be sure key in adapter and crankshaft keyway are aligned.
2. Position blade on the blade adapter aligning the two (2) holes in the blade

3. Be sure the trailing edge of blade (opposite sharp edge) is up toward the engine.
 4. Install the blade bolt with the lock washer and hardened washer into blade adapter and crankshaft.
 5. Use block of wood between blade and lawn mower housing and tighten the blade bolt, turning clockwise.
- The recommended tightening torque is 35-40 ft. lbs.

IMPORTANT: Blade bolt is grade 8 heat treated.

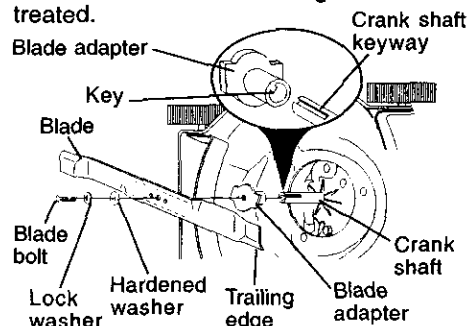

TO SHARPEN BLADE

NOTE: We do not recommend sharpening blade - but if you do, be sure the blade is balanced.

Care should be taken to keep the blade balanced. An unbalanced blade will cause eventual damage to lawn mower or engine.

- The blade can be sharpened with a file or on a grinding wheel. Do not attempt to sharpen while on the mower.
- To check blade balance, drive a nail into a beam or wall. Leave about one inch of the straight nail exposed. Place center hole of blade over the head of the nail. If blade is balanced, it should

remain in a horizontal position. If either end of the blade moves downward, sharpen the heavy end until the blade is balanced.

GRASS CATCHER

- The grass catcher may be hosed with water, but must be dry when used.
- Check your grass catcher often for damage or deterioration. Through normal use it will wear. If catcher needs replacing, replace only with a manufacturer approved replacement catcher. Give the lawn mower model number when ordering.

ENGINE LUBRICATION

Use only high quality detergent oil rated with API service classification SF-SJ. Select the oil's SAE viscosity grade according to your expected operating temperature.

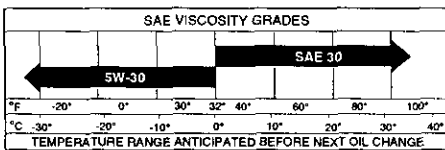

NOTE: Although multi-viscosity oils (5W30, 10W30 etc.) improve starting in cold weather, these multi-viscosity oils will result in increased oil consumption when used above 32°F. Check your engine oil level more frequently to avoid possible engine damage from running low on oil.

Change the oil after every 25 hours of operation or at least once a year if the lawn mower is not used for 25 hours in one year.

Check the crankcase oil level before starting the engine and after each five (5) hours of continuous use. Tighten oil plug securely each time you check the oil level.

TO CHANGE ENGINE OIL

NOTE: Before tipping lawn mower to drain oil, drain fuel tank by running engine until fuel tank is empty.

1. Disconnect spark plug wire from spark plug and place wire where it cannot come in contact with spark plug.
2. Remove engine oil cap; lay aside on a clean surface.
3. Tip lawn mower on its side as shown and drain oil into a suitable container. Rock lawn mower back and forth to remove any oil trapped inside engine.

4. Wipe off any spilled oil on lawn mower and on side of engine.
5. Fill engine with oil. (See "Add Oil" in the Operation section of this manual.)
6. Reconnect spark plug wire to spark plug.



AIR FILTER

Your engine will not run properly and may be damaged by using a dirty air filter. Replace the air filter every 100 hours of operation or every season, whichever occurs first. Service air cleaner more often under dusty conditions.

TO CLEAN AIR FILTER

1. Loosen screw and tilt cover to remove.
 2. Carefully remove cartridge.
 3. Clean by gently tapping on a flat surface. If very dirty, replace cartridge.
- CAUTION:** Petroleum solvents, such as kerosene, are not to be used to clean cartridge. They may cause deterioration of the cartridge. Do not oil cartridge. Do not use pressurized air to clean or dry cartridge.
4. Install cartridge, then replace cover making sure the tabs are aligned with the slots in the back plate. Fasten screw securely.

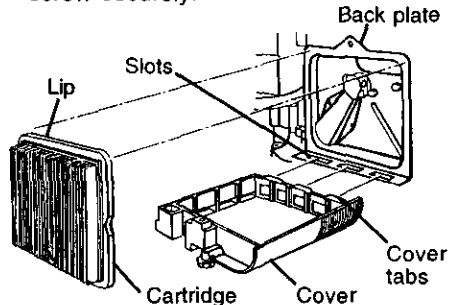

MUFFLER

Inspect and replace corroded muffler as it could create a fire hazard and/or damage.

SPARK PLUG

Replace spark plug at the beginning of each mowing season or after every 100 hours of operation, whichever occurs first. Spark plug type and gap setting are shown in "PRODUCT SPECIFICATIONS" section of this manual.

CLEANING

IMPORTANT: For best performance, keep mower housing free of built-up grass and trash. Clean the underside of your mower after each use.

CAUTION: Disconnect spark plug wire from spark plug and place wire where it cannot come in contact with the spark plug.

- Clean the underside of your lawn mower by scraping to remove build-up of grass and trash.

- Clean engine often to keep trash from accumulating. A clogged engine runs hotter and shortens engine life.
- Keep finished surfaces and wheels free of all gasoline, oil, etc.
- We do not recommend using a garden hose to clean lawn mower unless the electrical system, muffler, air filter and carburetor are covered to keep water out. Water in engine can result in shortened engine life.

SERVICE AND ADJUSTMENTS

CAUTION: Before performing any service and adjustments:

1. Release control bar and stop engine.
2. Make sure the blade and all moving parts have completely stopped.
3. Disconnect spark plug wire from spark plug and place where it cannot come in contact with plug.

LAWN MOWER

TO ADJUST CUTTING HEIGHT

See "TO ADJUST CUTTING HEIGHT" in the Operation section of this manual.

REAR DEFLECTOR

The rear deflector, attached between the rear wheels of your lawn mower, is provided to minimize the possibility that objects will be thrown out the rear of the lawn mower into the operator's mowing position. If the rear deflector becomes damaged, it should be replaced.

TO ADJUST HANDLE

The handle can be mounted in a high or low position. The mounting holes in the bottom of lower handle are off center for raising or lowering the handle.

1. Remove upper handle and all parts attached to lower handle.
2. Remove hairpin cotter from lower handle bracket mounting pin.
3. Squeeze lower handle in to remove it from mounting pins.
4. Turn lower handle over to raise or lower handle.
5. Squeeze lower handle in and position holes onto mounting pins on handle bracket.
6. Reassemble upper handle and all parts removed from lower handle.

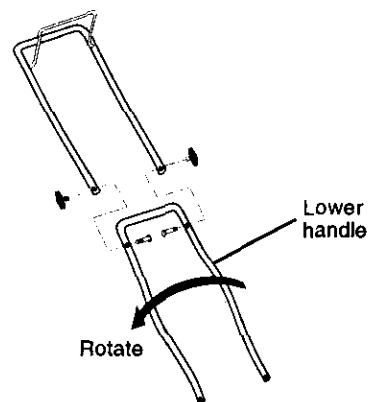

ENGINE

ENGINE SPEED

Your engine speed has been factory set. Do not attempt to increase engine speed or it may result in personal injury. If you believe that the engine is running too fast or too slow, take your lawn mower to a Sears or other qualified service center for repair and adjustment.

CARBURETOR

Your carburetor has a non-adjustable fixed main jet for mixture control. If your engine does not operate properly due to suspected carburetor problems, take your lawn mower to a Sears or other qualified service center for repair and/or adjustment.

IMPORTANT: Never tamper with the engine governor, which is factory set for proper engine speed. Overspeeding the engine above the factory high speed setting can be dangerous. If you think the engine-governed high speed needs adjusting, contact a Sears or other qualified service center, which has proper equipment and experience to make any necessary adjustments.

STORAGE

Immediately prepare your lawn mower for storage at the end of the season or if the unit will not be used for 30 days or more.

LAWN MOWER

When lawn mower is to be stored for a period of time, clean it thoroughly, remove all dirt, grease, leaves, etc. Store in a clean, dry area.

1. Clean entire lawn mower (See "CLEANING" in the Maintenance section of this manual).
2. Lubricate as shown in the Maintenance section of this manual.
3. Be sure that all nuts, bolts, screws, and pins are securely fastened. Inspect moving parts for damage, breakage and wear. Replace if necessary.
4. Touch up all rusted or chipped paint surfaces; sand lightly before painting.

HANDLE

You can fold your lawn mower handle for storage.

1. Squeeze the bottom ends of the lower handle toward each other until the lower handle clears the handle bracket, then move handle forward.
2. Loosen upper handle mounting bolts enough to allow upper handle to be folded back.

IMPORTANT: When folding the handle for storage or transportation, be sure to fold the handle as shown or you may damage the control cables.

- When setting up your handle from the storage position, the lower handle will automatically lock into the mowing position.

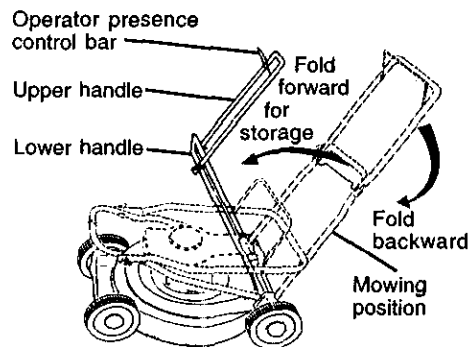
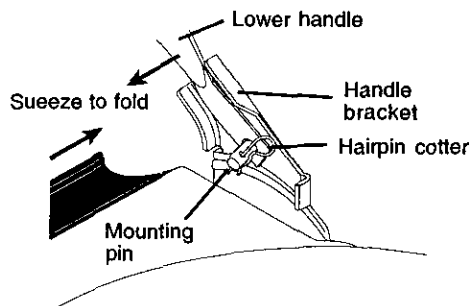

ENGINE

FUEL SYSTEM

IMPORTANT: It is important to prevent gum deposits from forming in essential fuel system parts such as carburetor, fuel filter, fuel hose or tank during storage.

Also, experience indicates that alcohol blended fuels (called gasohol or using ethanol or methanol) can attract moisture which leads to separation and formation of acids during storage. Acidic gas can damage the fuel system of an engine while in storage.

1. Drain the fuel tank.
2. Start the engine and let it run until the fuel lines and carburetor are empty.
 - Never use engine or carburetor cleaner products in the fuel tank or permanent damage may occur.
 - Use fresh fuel next season.

NOTE: Fuel stabilizer is an acceptable alternative in minimizing the formation of fuel gum deposits during storage. Add stabilizer to gasoline in fuel tank or storage container. Always follow the mix ratio found on stabilizer container. Run engine at least 10 minutes after adding stabilizer to allow the stabilizer to reach the carburetor. Do not drain the gas tank and carburetor if using fuel stabilizer.

ENGINE OIL

Drain oil (with engine warm) and replace with clean engine oil. (See "ENGINE" in the Maintenance section of this manual).

CYLINDER

1. Remove spark plug.
2. Pour one ounce (29 ml) of oil through spark plug hole into cylinder.
3. Pull starter handle slowly a few times to distribute oil.
4. Replace with new spark plug.

OTHER

- Do not store gasoline from one season to another.
- Replace your gasoline can if your can starts to rust. Rust and/or dirt in your gasoline will cause problems.

- If possible, store your unit indoors and cover it to give protection from dust and dirt.
- Cover your unit with a suitable protective cover that does not retain moisture. Do not use plastic. Plastic cannot breathe which allows condensation to form and will cause your unit to rust.

IMPORTANT: Never cover mower while engine and exhaust areas are still warm.

CAUTION: Never store the lawn mower with gasoline in the tank inside a building where fumes may reach an open flame or spark. Allow the engine to cool before storing in any enclosure.

TROUBLESHOOTING CHART

PROBLEM	CAUSE	CORRECTION
Does not start	<ol style="list-style-type: none"> 1. Dirty air filter. 2. Out of fuel. 3. Stale fuel. 4. Water in fuel. 5. Spark plug wire is disconnected. 6. Bad spark plug. 7. Loose blade or broken blade adapter. 8. Control bar in released position. 9. Control bar defective. 	<ol style="list-style-type: none"> 1. Clean/replace air filter. 2. Fill fuel tank. 3. Drain tank and refill with fresh clean fuel. 4. Drain fuel tank and carburetor and refill tank with fresh gasoline. 5. Connect wire to plug. 6. Replace spark plug. 7. Tighten blade bolt or replace blade adapter. 8. Depress control bar to handle. 9. Replace control bar.
Loss of power	<ol style="list-style-type: none"> 1. Rear of lawn mower housing or cutting blade dragging in heavy grass. 2. Cutting too much grass. 3. Dirty air filter. 4. Buildup of grass, leaves, and trash under mower. 5. Too much oil in engine. 6. Walking speed too fast. 	<ol style="list-style-type: none"> 1. Set to "Higher Cut" position. 2. Set to "Higher Cut" position. 3. Clean/replace air filter. 4. Clean underside of mower housing. 5. Check oil level. 6. Cut at slower walking speed.
Poor cut – uneven	<ol style="list-style-type: none"> 1. Worn, bent or loose blade. 2. Wheel heights uneven. 3. Buildup of grass, leaves and trash under mower. 	<ol style="list-style-type: none"> 1. Replace blade. Tighten blade bolt. 2. Set all wheels at same height 3. Clean underside of mower housing.
Excessive vibration	<ol style="list-style-type: none"> 1. Worn, bent or loose blade. 2. Bent engine crankshaft. 	<ol style="list-style-type: none"> 1. Replace blade. Tighten blade bolt. 2. Contact a Sears or other qualified service center.

TROUBLESHOOTING CHART

PROBLEM	CAUSE	CORRECTION
Starter rope hard to pull	<ol style="list-style-type: none"> 1. Engine flywheel brake is on when control bar is released. 2. Bent engine crankshaft. 3. Blade adapter broken. 4. Blade dragging in grass. 	<ol style="list-style-type: none"> 1. Depress control bar to upper handle before pulling starter rope. 2. Contact a Sears or other qualified service center. 3. Replace blade adapter. 4. Move lawn mower to cut grass or to hard surface.
Grass catcher not filling (if so equipped)	<ol style="list-style-type: none"> 1. Cutting height too low. 2. Lift on blade worn off. 3. Catcher not venting air. 	<ol style="list-style-type: none"> 1. Raise cutting height. 2. Replace blade. 3. Clean grass catcher.
Hard to push	<ol style="list-style-type: none"> 1. Grass is too high or wheel height is too low. 2. Rear of lawn mower housing or blade dragging in grass. 3. Grass catcher too full. 4. Handle height position not right for you. 	<ol style="list-style-type: none"> 1. Raise cutting height. 2. Raise rear of lawn mower housing one (1) setting higher. 3. Empty grass catcher. 4. Adjust handle height to suit.

ROTARY LAWN MOWER MODEL NUMBER 944.361530

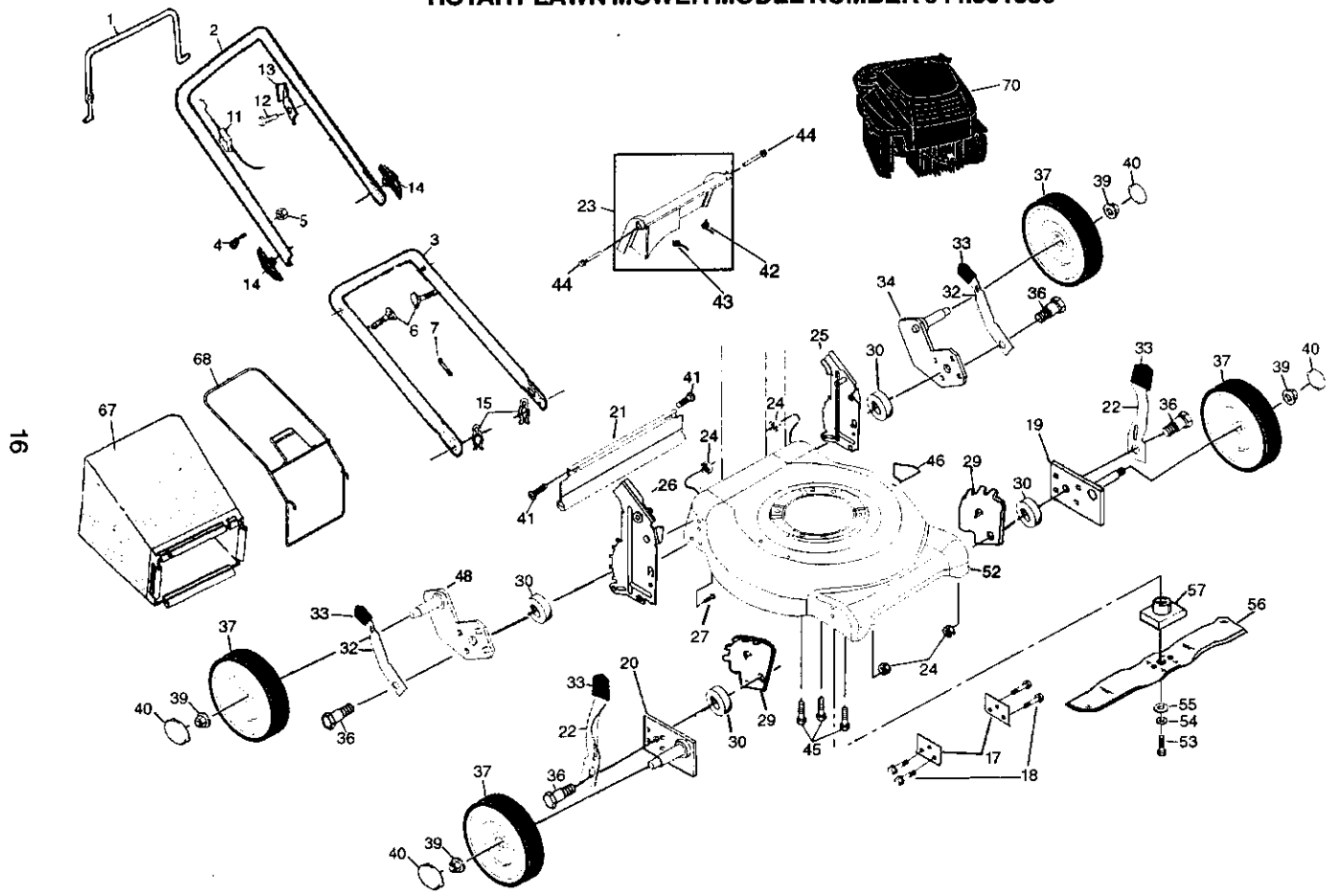

16

REPAIR PARTS

ROTARY LAWN MOWER MODEL NUMBER 944.361530

KEY PART NO. NO.	DESCRIPTION	KEY PART NO. NO.	DESCRIPTION	
1	86902	Control Bar	34 165762X004 Axle Arm Assembly - LR	
2	169709X479	Upper Handle	36 160828	Shoulder Bolt 5/16-18
3	169708X479	Lower Handle	37 151157	Wheel Assembly
4	132001	Rope Guide	39 83923	Flanged Locknut
5	63601	Locknut 1/4-20	40 77400	Hubcap
6	131959	Handle Bolt	41 88652	Hinge Screw
7	66426	Wire Tie	42 165766	Spring (LH)
11	176556	Engine Zone Control Cable	43 165767	Spring (RH)
12	750097	Hex Washer Head Screw #10-24 x 1/2	44 165912	Door Bolt
13	86899X004	Up-Stop Bracket	45 150406	Hex Head Thread Rolling Screw 3/8-16 x 1
14	136376	Handle Knob	46 107339X	Danger Decal
15	51793	Hairpin Cotter	48 165761X004	Axle Arm Assembly - RR
17	165946X479	Support Bracket	52 173319	Housing Assembly (Incl. Ref. #17, 18 & 46)
18	17600406	Screw	53 851084	Hex Head Screw 3/8-24 x 1-3/8 Grd. 8
19	167132X004	Axle Arm Assembly - LF	54 850263	Helical Lockwasher
20	167133X004	Axle Arm Assembly - RF	55 851074	Hardened Washer
21	165858	Rear Skirt	56 165833	21" Blade
22	168360X004	Selector Spring - Front	57 851514	Blade Adapter
23	166875	Rear Door Assembly Kit (Incl. Springs)	67 167710	Grass Bag
24	751153	Locknut 5/16-18	68 165755	Catcher Frame
25	166111X479	Handle Bracket Assembly (Left)	70 - - - - -	Engine - (See Breakdown)
26	166112X479	Handle Bracket Assembly (Right)	-- 162300	Briggs & Stratton 12H802-2639-B1
27	851856	Screw 1/4-20 x 3/8	-- 177510	Warning Decal (Not Shown)
29	160835X007	Wheel Adjusting Bracket - Front	-- 177511	Owner's Manual (English)
30	19112222	Spacer		Owner's Manual (French)
32	169421X004	Selector Spring - Rear		
33	87877	Selector Knob		

NOTE: All component dimensions given in U.S. inches
1 inch = 25.4 mm

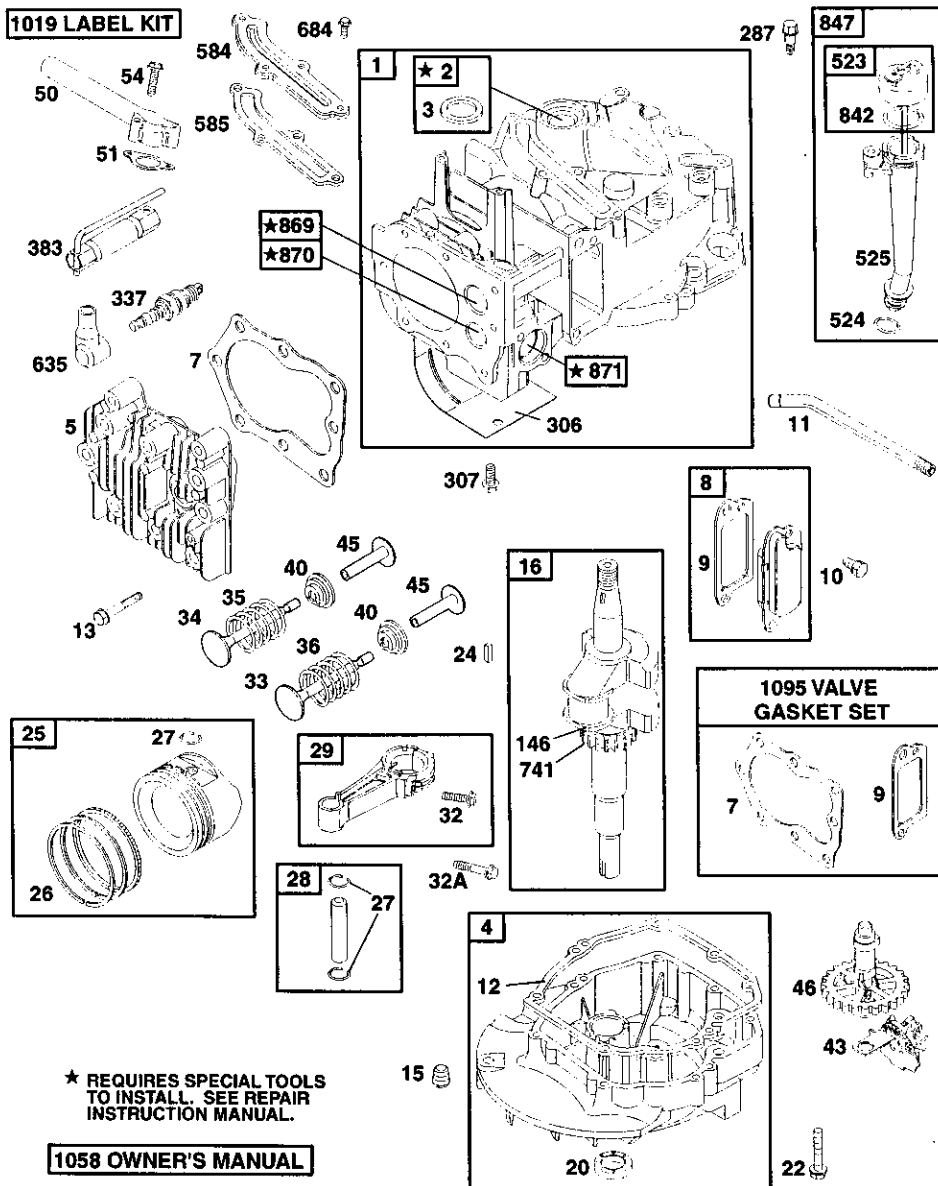

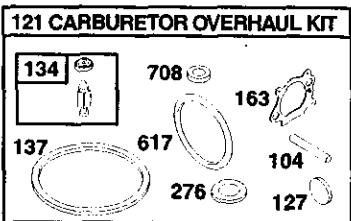
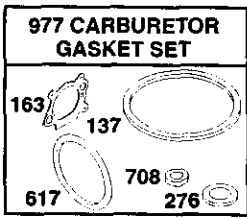
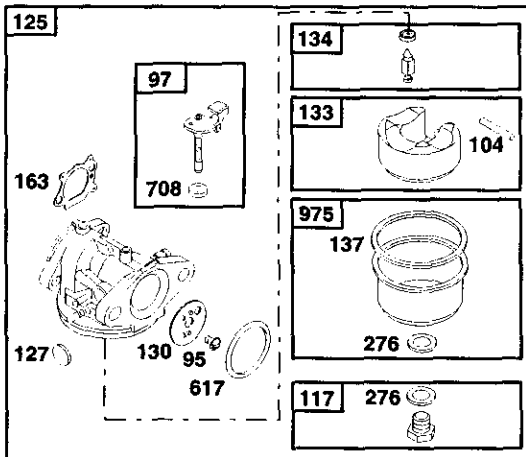
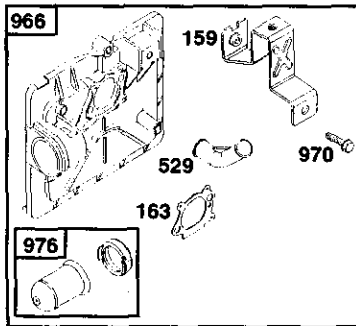
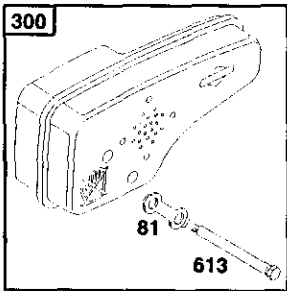
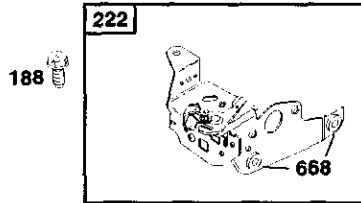
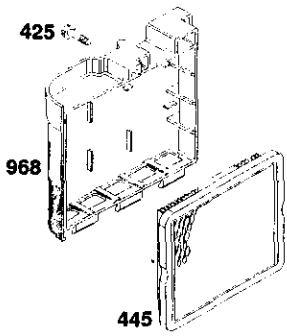

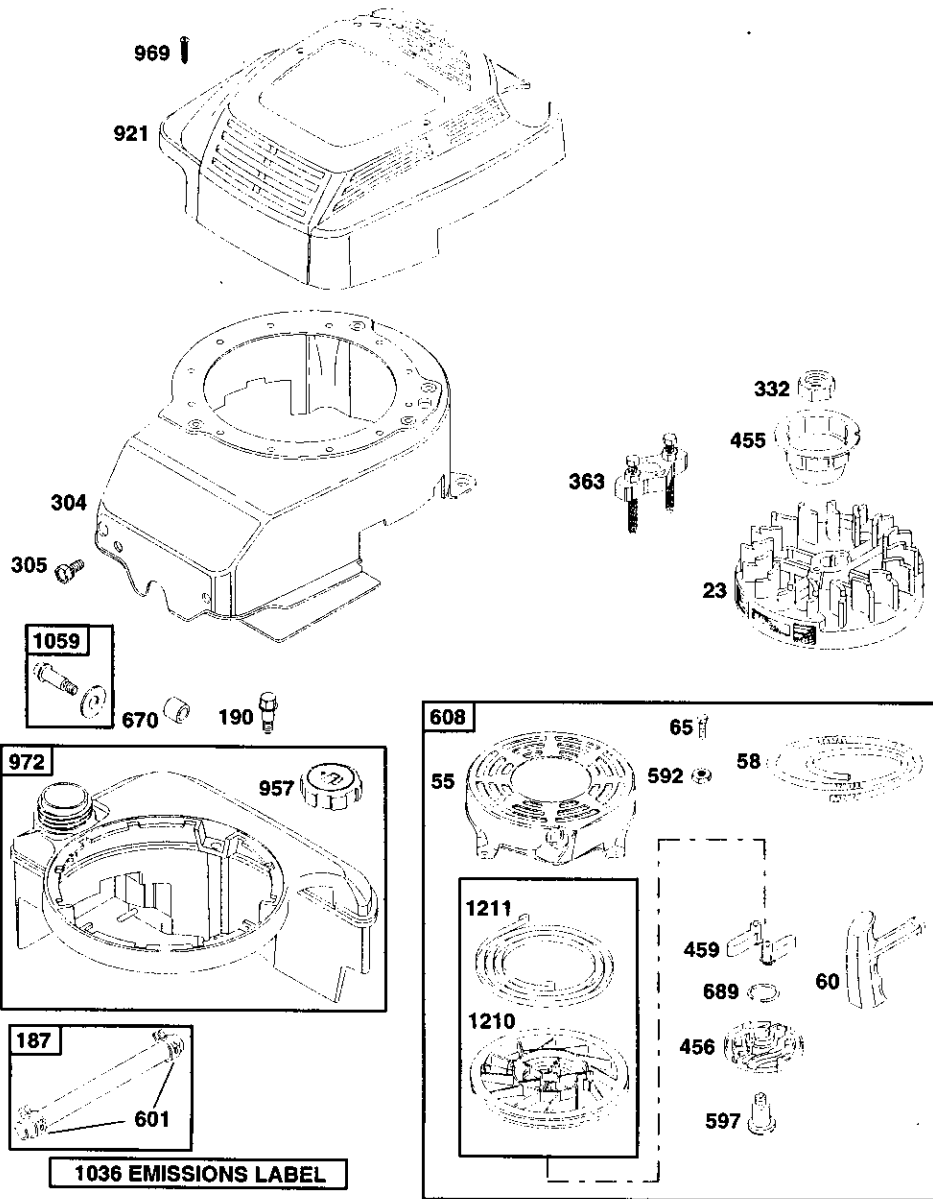

BRIGGS & STRATTON ENGINE

MODEL NUMBER 12H802, TYPE NUMBER 2639-B1

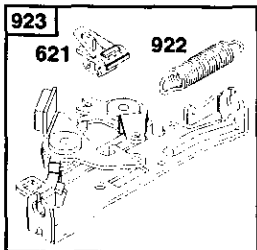
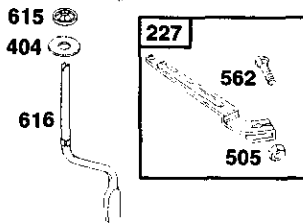
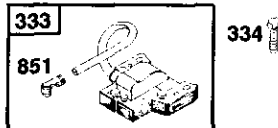
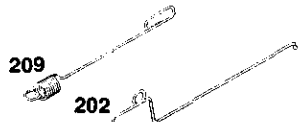
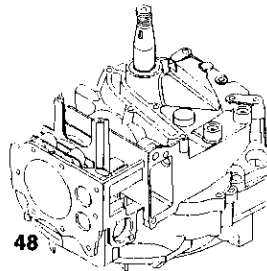
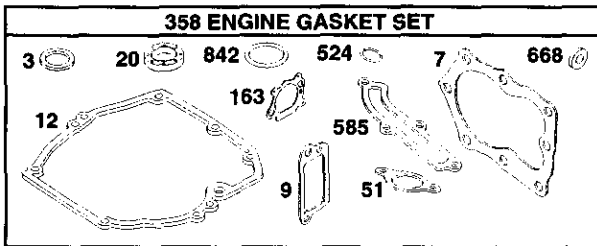

KEY PART NO.	PART NO.	DESCRIPTION	KEY PART NO.	PART NO.	DESCRIPTION
1	493260	Cylinder Assembly	48	498826	Short Block (Replacement Engine 12J802-2915-B1)
2	399269	Kit-Bushing/Seal	50	497465	Manifold-Intake
3	299819	• Seal-Oil (Magneto Side)	51	272199	• Gasket-Intake
4	493279	Sump-Engine	54	691650	Screw (Intake Manifold)
5	691160	Head-Cylinder	55	691421	Housing-Rewind Starter
7	692249	+ Gasket-Cylinder Head	58	692259	Rope-Starter (Cut to Length)
8	695250	Breather Assembly	60	281434	Grip-Starter Rope
9	272481	+ Gasket-Breather	65	690759	Screw (Rewind Starter)
10	691125	Screw (Breather Assembly)	81	691740	Lock-Muffler Screw
11	691781	Tube-Breather	95	691636	Screw (Throttle Valve)
12	692232	• Gasket-Crankcase	97	493267	Shaft-Throttle
13	690912	Screw (Cylinder Head)	104	691242	Ø Pin-Float Hinge
15	691680	Plug-Oil Drain	117	494870	Jet-Main (Standard)
16	691451	Crankshaft		497315	Jet-Main (High Altitude)
20	399781	• Seal-Oil (PTO Side)	121	498260	Kit-Carburetor Overhaul
22	691092	Screw (Engine Sump)	125	498170	Carburetor
23	692315	Flywheel	127	694468	Ø Plug-Welch
24	222698	Key-Flywheel	130	691203	Valve-Throttle
25	499429	Piston Assembly (Standard)	133	398187	Float-Carburetor
	499430	Piston Assembly (.010" O.S.)	134	398188	Ø Valve-Needle/Seat
	499431	Piston Assembly (.020" O.S.)	137	693981	Ø‡ Gasket-Float Bowl
	499432	Piston Assembly (.030" O.S.)	146	690979	Key-Timing
26	499425	Ring Set-Piston (Standard)	159	691753	Bracket-Air Cleaner Primer
	499426	Ring Set-Piston (.010" O.S.)	163	272653	•Ø‡ Gasket-Air Cleaner
	499427	Ring Set-Piston (.020" O.S.)	187	691050	Line-Fuel (Cut to Length)
	499428	Ring Set-Piston (.030" O.S.)	188	690877	Screw (Control Bracket)
27	691866	Lock-Piston Pin	190	690940	Screw (Fuel Tank)
28	499423	Pin-Piston	202	691829	Link-Mechanical Governor
29	499424	Rod-Connecting	209	690319	Spring-Governor
32	691664	Screw (Connecting Rod)	222	692467	Bracket-Control
32A	695759	Screw (Connecting Rod)	227	690783	Control Lever-Governor
33	262651	Valve-Exhaust	276	271716	Ø‡ Sealing Washer
34	262652	Valve-Intake	287	690940	Screw (Dipstick Tube)
35	691270	Spring-Valve (Intake)	300	692038	Muffler
36	691270	Spring-Valve (Exhaust)	304	695892	Housing-Blower
40	692194	Retainer-Valve	305	691108	Screw (Blower Housing)
43	691997	Slinger-Governor/Oil	306	690450	Shield-Cylinder
45	690548	Tappet-Valve	307	690345	Screw (Cylinder Shield)
46	691449	Camshaft			

BRIGGS & STRATTON ENGINE

MODEL NUMBER 12H802, TYPE NUMBER 2639-B1

KEY PART NO.	PART NO.	DESCRIPTION	KEY PART NO.	PART NO.	DESCRIPTION
332	690662	Nut (Flywheel)	689	691855	Spring-Friction
333	802574	Armature-Magneto	708	691321	Ø‡ Seal-Throttle Shaft
334	691061	Screw (Armature Magneto)	741	691830	• Gear-Timing
337	802592	Spark Plug	842	691031	• Seal-O Ring (Dipstick Tube)
356	692390	Wire-Stop	847	692017	Assembly-Dipstick/Tube
358	497316	Engine Gasket Set	851	493880	Terminal-Sparkplug
363	19069	Flywheel Puller	869	691155	Seat-Valve (Intake)
365	692524	Screw (Carburetor)	870	690380	Seat-Valve (Exhaust)
383	89838	Wrench-Spark Plug	871	262001	Bushing-Guide (Exhaust)
404	690272	Washer (Governor Crank)		63709	Bushing-Guide (Intake)
425	690670	Screw (Air Cleaner Cover)	921	497233	Cover-Blower Housing
443	692523	Screw (Air Cleaner Primer Base)	922	692135	Spring-Brake
445	491588	Filter-Air Cleaner Cartridge	923	695891	Brake
455	691219	Cup-Flywheel	957	397974	Cap-Fuel Tank
456	692299	Plate-Pawl Friction	966	496116	Base-Air Cleaner Primer
459	281505	Pawl-Ratchet	968	692298	Cover-Air Cleaner
505	231082	Nut (Governor Control Lever)	969	690700	Screw (Blower Housing Cover)
523	495264	Dipstick	970	691669	Screw
524	692296	• Seal-Dipstick Tube			(Air Cleaner Primer Bracket)
525	495265	Tube-Dipstick	972	495224	Tank-Fuel
529	691923	Grommet	975	493640	Bowl-Float
562	92613	Bolt (Governor Control Lever)	976	496115	Primer-Carburetor
584	692342	Cover-Breather Passage	977	498261	Set-Carburetor Gasket
585	691879	• Gasket-Breather Passage	1019	494256	Kit-Label
592	690800	Nut (Rewind Starter)	1036	695111	Label-Emissions
597	691696	Screw (Pawl Friction Plate)	1058	274265	Owner's Manual
601	95162	Clamp-Hose	1059	692311	Kit-Screw/Washer
608	497680	Starter-Rewind	1095	498528	Set-Valve Gasket
613	691340	Screw (Muffler)	1210	498144	Assy-Pulley/Spring (Pulley)
615	690340	Retainer-Governor Shaft	1211	498144	Assy-Pulley/Spring (Spring)
616	691306	Crank-Governor			
617	270344	Ø‡ Seal-O Ring (Intake Manifold)	•		included in Engine Gasket Set, Key #358
621	692310	Switch-Stop	Ø		Included in Carburetor Overhaul Kit, Key #121
635	66538	Boot-Sparkplug	‡		Included in Carburetor Gasket Set, Key #977
668	493823	• Spacer (Includes 2)	+		Included in Valve Overhaul Kit, Key #1095
670	692294	Spacer-Fuel Tank			
684	690345	Screw (Breather Passage Cover)			

NOTE: All component dimensions given in U.S. inches
1 inch = 25.4 mm



Get it fixed, at your home or ours!

1-800-4-MY-HOME®

(1-800-469-4663)

Call 24 hours a day, 7 days a week

www.sears.ca

For Parts call

1-800-4-MY-HOME®

(1-800-469-4663)

Call 24 hours a day, 7 days a week

To purchase or inquire about a Sears Maintenance Agreement:

1-800-361-6665

Mon. to Sat.

Pour service en français:

1-887-LE-FOYER®

(1-877-533-6937)



Free Manuals Download Website

<http://myh66.com>

<http://usermanuals.us>

<http://www.somanuals.com>

<http://www.4manuals.cc>

<http://www.manual-lib.com>

<http://www.404manual.com>

<http://www.luxmanual.com>

<http://aubethermostatmanual.com>

Golf course search by state

<http://golfingnear.com>

Email search by domain

<http://emailbydomain.com>

Auto manuals search

<http://auto.somanuals.com>

TV manuals search

<http://tv.somanuals.com>