

**SEARS**

**OWNER'S  
MANUAL**

**MODEL NO.  
944.524591**

**Caution:**  
Read and follow  
all Safety Rules  
and Instructions  
Before Operating  
This Equipment

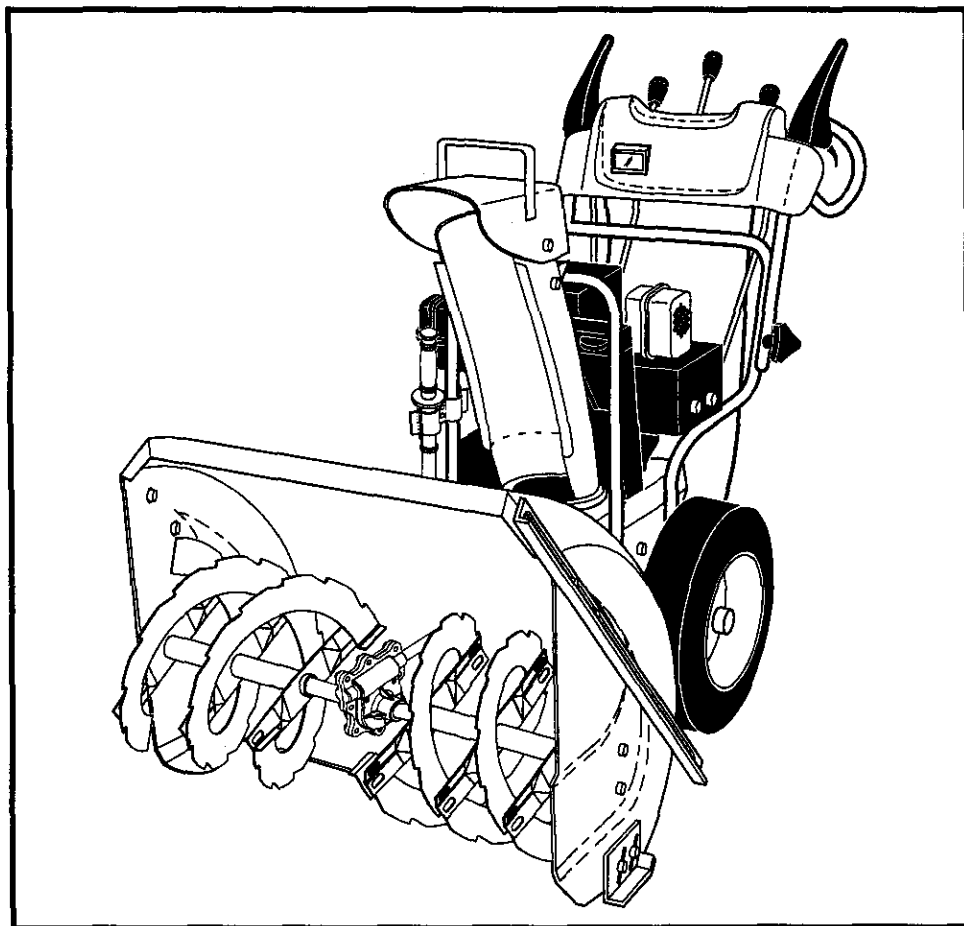

**CRAFTSMAN®**

**9.5 HP  
27" TWO-STAGE  
POWER-PROPELLED  
SNOW THROWER**

- Assembly
- Operation
- Maintenance
- Service and Adjustments
- Repair Parts

## IMPORTANT

### Safe Operation Practices for Walk-Behind Snow Throwers

This snow thrower is capable of amputating hands and feet and throwing objects. Failure to observe the following safety instructions could result in serious injury.



Look for this symbol to point out important safety precautions. It means **CAUTION!!! BECOME ALERT!!! YOUR SAFETY IS INVOLVED.**



**WARNING:** Always disconnect spark plug wire and place it where it cannot contact plug in order to prevent accidental starting when setting up, transporting, adjusting or making repairs.



**WARNING:** This snow thrower is for use on sidewalks, driveways and other ground level surfaces. Caution should be exercised while using on sloping surfaces. Do not use snow thrower on surfaces above ground level such as roofs of residences, garages, porches or other such structures or buildings.



**WARNING:** Snow throwers have exposed rotating parts, which can cause severe injury from contact, or from material thrown from the discharge chute. Keep the area of operation clear of all persons, small children and pets at all times including startup.



**CAUTION:** Muffler and other engine parts become extremely hot during operation and remain hot after engine has stopped. To avoid severe burns on contact, stay away from these areas.



**WARNING:** Engine exhaust, some of its constituents, and certain vehicle components contain or emit chemicals known to the State of California to cause cancer and birth defects or other reproductive harm.

### Training

1. Read, understand and follow all instructions on the machine and in the manual(s) before operating this unit. Be thoroughly familiar with the controls and the proper use of the equipment. Know how to stop the unit and disengage the controls quickly.
2. Never allow children to operate the equipment. Never allow adults to operate the equipment without proper instruction.
3. Keep the area of operation clear of all persons, particularly small children.
4. Exercise caution to avoid slipping or falling, especially when operating the snow thrower in reverse.

### Preparation

1. Thoroughly inspect the area where the equipment is to be used and remove all doormats, sleds, boards, wires, and other foreign objects.
2. Disengage all clutches and shift into neutral before starting the engine (motor).
3. Do not operate the equipment without wearing adequate winter garments. Avoid loose fitting clothing that can get caught in moving parts. Wear footwear that will improve footing on slippery surfaces.
4. Handle fuel with care; it is highly flammable
  - (a) Use an approved fuel container.
  - (b) Never add fuel to a running engine or hot engine.
  - (c) Fill fuel tank outdoors with extreme care. Never fill fuel tank indoors.
  - (d) Never fill containers inside a vehicle or on a truck or trailer bed with a plastic liner. Always place containers on the ground, away from your vehicle, before filling.
  - (e) When practical, remove gas-powered equipment from the truck or trailer and refuel it on the ground. If this is not possible, then refuel such equipment on a trailer with a portable container, rather than from a gasoline dispenser nozzle.

- (f) Keep the nozzle in contact with the rim of the fuel tank or container opening at all times, until refueling is complete. Do not use a nozzle lock-open device.
  - (g) Replace gasoline cap securely and wipe up spilled fuel.
  - (h) If fuel is spilled on clothing, change clothing immediately.
5. Use extension cords and receptacles as specified by the manufacturer for all units with electric drive motors or electric starting motors.
  6. Adjust the collector housing height to clear gravel or crushed rock surface.
  7. Never attempt to make any adjustments while the engine (motor) is running (except when specifically recommended by manufacturer).
  8. Always wear safety glasses or eye shields during operation or while performing an adjustment or repair to protect eyes from foreign objects that may be thrown from the machine.

### Operation

1. Do not put hands or feet near or under rotating parts. Keep clear of the discharge opening at all times.
2. Exercise extreme caution when operating on or crossing gravel drives, walks, or roads. Stay alert for hidden hazards or traffic.
3. After striking a foreign object, stop the engine (motor), remove the wire from the spark plug, disconnect the cord on electric motors, thoroughly inspect the snow thrower for any damage, and repair the damage before restarting and operating the snow thrower.
4. If the unit should start to vibrate abnormally, stop the engine (motor) and check immediately for the cause. Vibration is generally a warning of trouble.
5. Stop the engine (motor) whenever you leave the operating position, before unclogging the collector/impeller housing or discharge chute, and when making any repairs, adjustments or inspections.

6. When cleaning, repairing or inspecting the snow thrower, stop the engine and make certain the collector/impeller and all moving parts have stopped. Disconnect the spark plug wire and keep the wire away from the plug to prevent someone from accidentally starting the engine.
7. Do not run the engine indoors, except when starting the engine and for transporting the snow thrower in or out of the building. Open the outside doors; exhaust fumes are dangerous.
8. Exercise extreme caution when operating on slopes.
9. Never operate the snow thrower without proper guards, and other safety protective devices in place and working.
10. Never direct the discharge toward people or areas where property damage can occur. Keep children and others away.
11. Do not overload the machine capacity by attempting to clear snow at too fast a rate.
12. Never operate the machine at high transport speeds on slippery surfaces. Look behind and use care when operating in reverse.
13. Disengage power to the collector/impeller when snow thrower is transported or not in use.
14. Use only attachments and accessories approved by the manufacturer of the snow thrower (such as wheel weights, counterweights, or cabs).
15. Never operate the snow thrower without good visibility or light. Always be sure of your footing, and keep a firm hold on the handles. Walk; never run.
16. Never touch a hot engine or muffler.

## Clearing a Clogged Discharge Chute

Hand contact with the rotating impeller inside the discharge chute is the most common cause of injury associated with snow throwers. Never use your hand to clean out the discharge chute. To clear the chute:

1. SHUT THE ENGINE OFF!
2. Wait 10 seconds to be sure the impeller blades have stopped rotating.
3. Always use a clean-out tool, not your hands.

## Maintenance and Storage

1. Check shear bolts and other bolts at frequent intervals for proper tightness to be sure the equipment is in safe working condition.
2. Never store the machine with fuel in the fuel tank inside a building where ignition sources are present such as hot water heaters, space heaters, or clothes dryers. Allow the engine to cool before storing in any enclosure.
3. Always refer to operator's manual for important details if the snow thrower is to be stored for an extended period.
4. Maintain or replace safety and instruction labels, as necessary.
5. Run the machine a few minutes after throwing snow to prevent freeze-up of the collector/impeller.

---

# TABLE OF CONTENTS

---

<b>SAFETY RULES</b> .....	2-3
<b>PRODUCT SPECIFICATIONS</b> .....	4
<b>CUSTOMER RESPONSIBILITIES</b> .....	4
<b>WARRANTY</b> .....	4
<b>ASSEMBLY / PRE-OPERATION</b> .....	6-8
<b>OPERATION</b> .....	9-15

<b>MAINTENANCE</b> .....	15-16
<b>MAINTENANCE SCHEDULE</b> .....	15
<b>SERVICE AND ADJUSTMENTS</b> .....	17-19
<b>STORAGE</b> .....	19
<b>TROUBLESHOOTING</b> .....	20
<b>REPAIR PARTS</b> .....	22-38
<b>SEARS SERVICE</b> .....	BACK COVER

## LIMITED TWO (2) YEAR WARRANTY ON CRAFTSMAN SNOW THROWER

For two (2) years from date of purchase Sears Canada, Inc. will repair or replace, at Sears option, free of charge parts which are defective as a result of material or workmanship.

### COMMERCIAL OR RENTAL USE:

Warranty on Snow Thrower will be 90 days from date of purchase if used for commercial or rental purposes.

### This Warranty does NOT cover:

1. Pre-delivery set-up.
2. Expendable items which become worn during normal use, such as belts, spark plugs, air cleaners, and shear pins, as well damage to the engine resulting from operating snow thrower with insufficient oil.
3. Repairs necessary because of operator abuse or negligence, including the failure to operate and maintain the equipment according to the instructions contained in the Owner's Manual.
4. Tire replacement or repair caused by punctures from outside objects, such as nails, thorns, stumps or glass.

Warranty service is available by returning the Craftsman Snow Thrower to the nearest Sears Service Centre/Department in Canada. This warranty applies only while this product is in use in Canada.

This warranty is in addition to any statutory warranty and does NOT exclude or limit legal rights you may have but shall run concurrently with applicable provincial legislation. Furthermore, some provinces do not allow limitations on how long an implied warranty will last, so the above limitations may not apply to you.

Sears Canada, Inc., Toronto, Ontario M5B 2B8

**CONGRATULATIONS** on your purchase of a new snow thrower. It has been designed, engineered and manufactured to give best possible dependability and performance.

Should you experience any problem you cannot easily remedy, please contact your nearest Sears service centre/department. We have competent, well-trained technicians and the proper tools to service or repair this unit.

Please read and retain this manual. The instructions will enable you to assemble and maintain your snow thrower properly. Always observe the "SAFETY RULES".

SERIAL NUMBER: \_\_\_\_\_

DATE OF PURCHASE: \_\_\_\_\_

THE MODEL AND SERIAL NUMBERS WILL BE FOUND ON A DECAL ATTACHED TO THE REAR OF THE SNOW THROWER HOUSING.

YOU SHOULD RECORD BOTH SERIAL NUMBER AND DATE OF PURCHASE AND KEEP IN A SAFE PLACE FOR FUTURE REFERENCE.

## PRODUCT SPECIFICATIONS

Gasoline Capacity and Type:	4,54 Liters Unleaded Regular only
Oil Type (API SG-SL):	SAE 5W-30 or 10W-30 (0°F to +40°F / -18°C to +5°C) Synthetic SAE 5W-30 or 10W-30 (below 0°F / -18°C)
Oil Capacity:	0,8 Liters
Spark Plug: Gap:	Champion RC12YC 0,072 mm

## CUSTOMER RESPONSIBILITIES

- Read and observe the safety rules.
- Follow a regular schedule in maintaining, caring for and using your snow thrower.
- Follow the instructions under "Maintenance" and "Storage" sections of this owner's manual.

# PARTS PACKED SEPARATELY IN CARTON

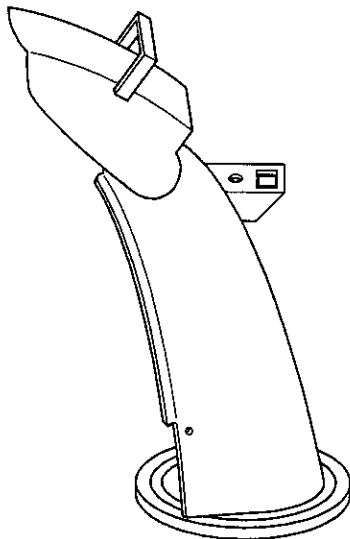

(1) DISCHARGE CHUTE

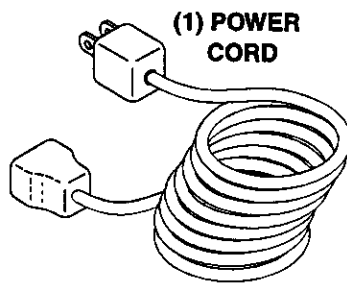

(1) POWER CORD

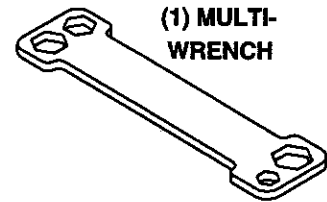

(1) MULTI-WRENCH



(1) TRACTION DRIVE CONTROL ROD

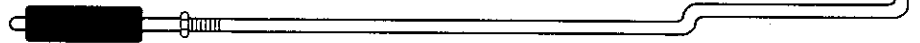

(1) AUGER CONTROL ROD

## EXTRA SHEAR BOLTS AND NUTS

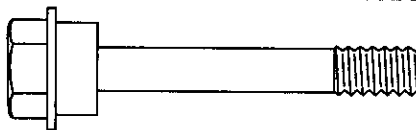

(4) SHOULDER BOLTS  
1/4-20 x 2 (AUGER SHAFT)

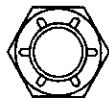

(8) LOCKNUTS  
1/4-20

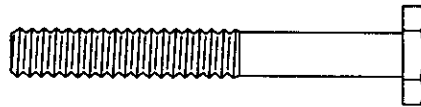

(4) CAPSCREWS  
1/4-20 x 1-5/8 (IMPELLER)

## ROTATER HEAD MOUNTING

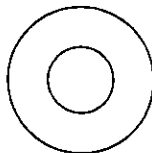

(1) WASHER 3/8

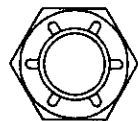

(1) LOCKNUT 3/8



(3) RETAINER SPRINGS

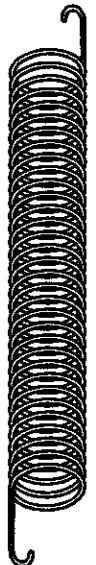

(1) SPRING

## CHUTE DEFLECTOR REMOTE CONTROL

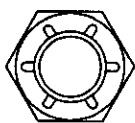

(1) LOCKNUT  
5/16-18

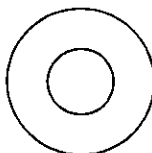

(1) WASHER

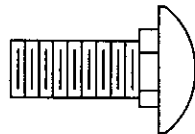

(1) CARRIAGE BOLT  
5/16-18 x 5/8

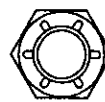

(1) LOCKNUT  
1/4-20



(1) NYLON WASHER

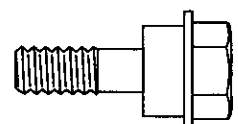

(1) SHOULDER BOLT  
1/4-20

# ASSEMBLY / PRE-OPERATION

Read these instructions and this manual in its entirety before you attempt to assemble or operate your new snow thrower.

Your new snow thrower has been assembled at the factory with the exception of those parts left unassembled for shipping purposes. All parts such as nuts, washers, bolts, etc., necessary to complete the assembly have been placed in the parts bag. To ensure safe and proper operation of your snow thrower, all parts and hardware you assemble must be tightened securely. Use the correct tools as necessary to ensure proper tightness.

## REMOVE SNOW THROWER FROM CARTON

1. Remove all accessible loose parts and parts boxes from carton.
2. Cut down all four corners of carton and lay panels flat.
3. Remove all packing materials except plastic tie holding speed control rod to lower handle.
4. Remove snow thrower from carton and check carton thoroughly for additional loose parts.

## HOW TO SET UP YOUR SNOW THROWER

### TOOL BOX (See Fig. 10)

A toolbox is provided on your snow thrower. The toolbox is located on top of the belt cover. Store the extra shear bolts, nuts and multi-wrench provided in parts bag in the toolbox.

**NOTE:** The multi-wrench may be used for assembly of the chute rotator head to snow thrower and making adjustments to the skid plates.

### UNFOLD UPPER HANDLE

1. Raise upper handle to the operating position and tighten handle knobs securely.

## INSTALL SPEED CONTROL ROD (See Figs. 1 and 2)

1. Remove plastic tie securing rod to lower handle.
2. Insert rod into speed control bracket and secure with retainer spring.

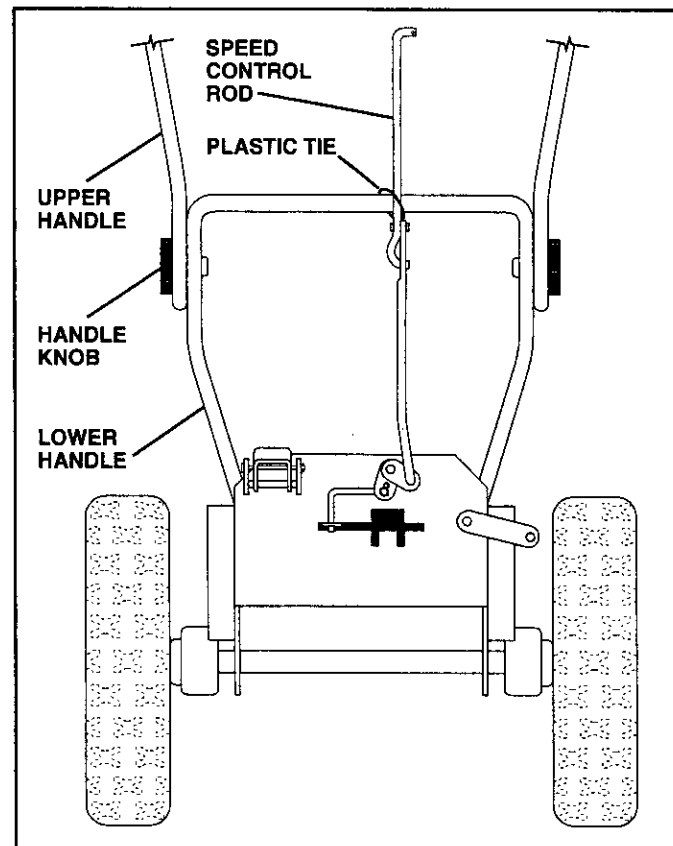

FIG. 1

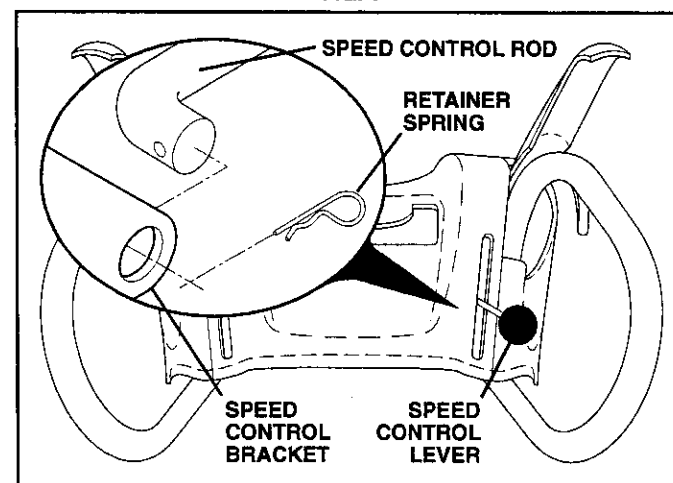

FIG. 2

# ASSEMBLY / PRE-OPERATION

## INSTALL TRACTION DRIVE CONTROL ROD

(See Figs. 3 and 4)

The traction drive control rod has the long loop on the end of the spring as shown.

1. Slide rubber sleeve up rod and hook end of spring into pivot bracket with loop opening down as shown.
2. With top end of rod positioned under left side of control panel, push rod down and insert top end of rod into hole in drive control bracket. Secure with retainer spring.

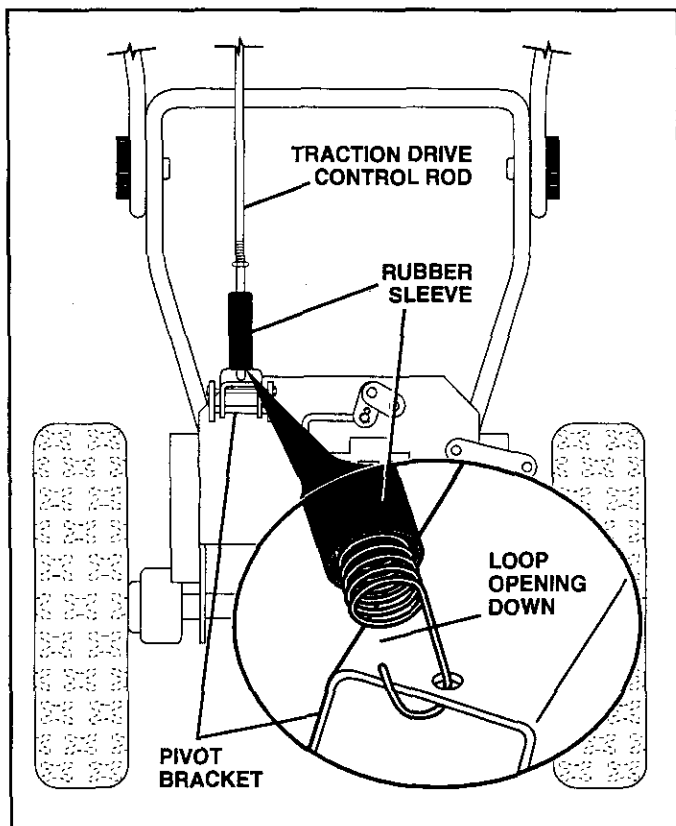

FIG. 3

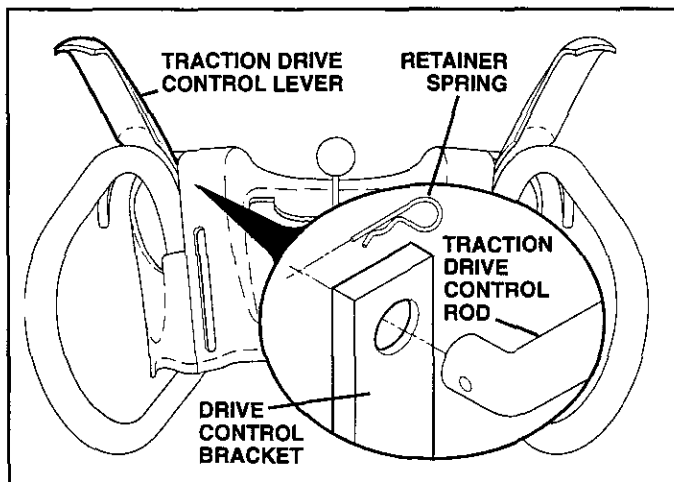

FIG. 4

## INSTALL AUGER CONTROL ROD (See Figs. 5 and 6)

The auger control rod has the short loop on the end of the spring as shown.

1. Slide rubber sleeve up rod and hook end of spring into control arm with loop opening up as shown.
2. With top end of rod positioned under right side of control panel, push down on rod and insert end of rod into hole in auger control bracket. Secure with retainer spring.

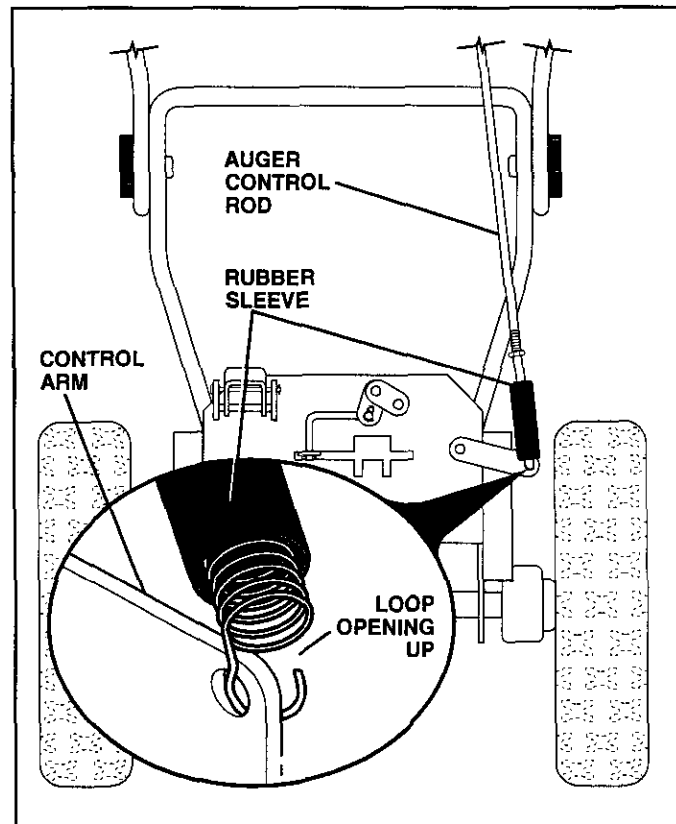

FIG. 5

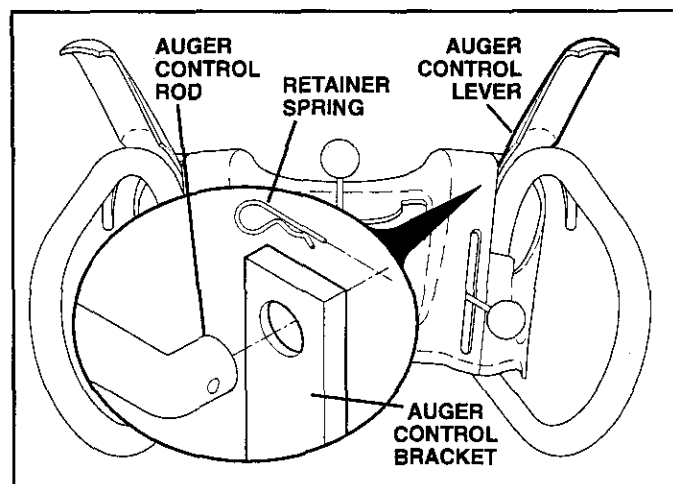

FIG. 6

# ASSEMBLY / PRE-OPERATION

## INSTALL DISCHARGE CHUTE/CHUTE ROTATER HEAD (See Fig. 7)

**NOTE:** The multi-wrench provided in your parts bag may be used to install the chute rotater head.

1. Place discharge chute assembly on top of chute base with discharge opening toward front of snow thrower.
2. Position chute rotater head over chute bracket. If necessary, rotate chute assembly to align square and pin on underside of chute rotater head with holes in chute bracket.
3. With chute rotater head and chute bracket aligned, position chute rotater head on pin and threaded stud of mounting bracket.
4. Install 3/8 washer and locknut on threaded stud and tighten securely.

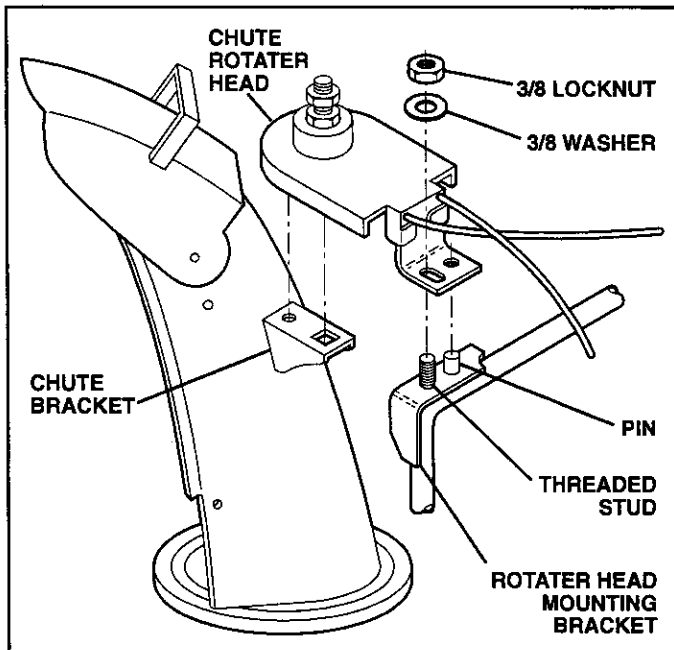

FIG. 7

## INSTALL CHUTE DEFLECTOR REMOTE CONTROL (See Figs. 8 and 9)

1. Install remote cable bracket to discharge chute with 5/16-18 carriage bolt, flat washer and 5/16-18 locknut as shown. Tighten securely.
2. Install remote cable eyelet to chute deflector with 1/4-20 shoulder bolt, nylon washer and 1/4-20 locknut as shown. Tighten securely.
3. Install spring hooks between hex nuts on chute rotater head and into hole in chute deflector as shown.

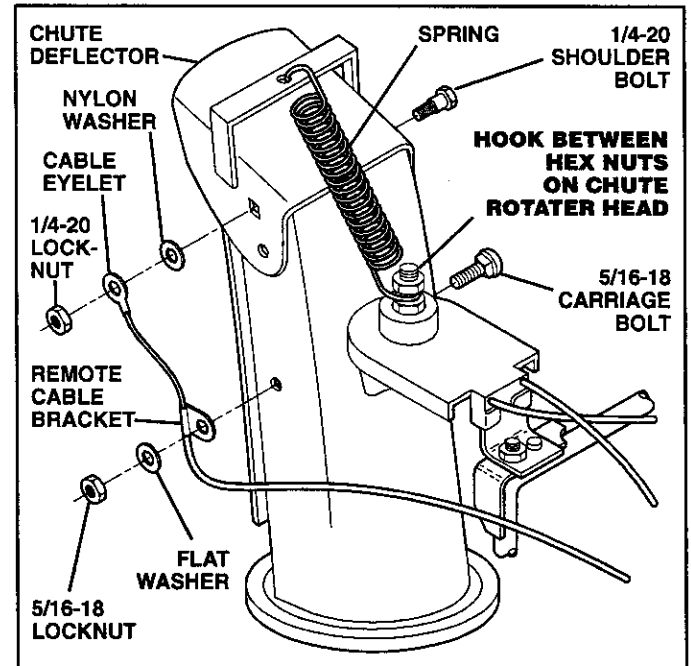

FIG. 8

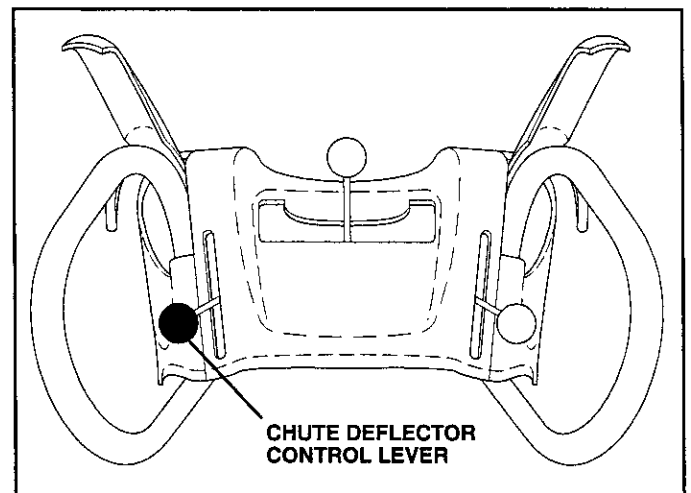

FIG. 9

## CHECK TIRE PRESSURE

The tires on your snow thrower were overinflated at the factory for shipping purposes. Correct and equal tire pressure is important for best snow throwing performance.

- Reduce tire pressure to 14-17 PSI (19-24.5 N-m).



# OPERATION

## KNOW YOUR SNOW THROWER

READ THIS OWNER'S MANUAL AND ALL SAFETY RULES BEFORE OPERATING YOUR SNOW THROWER. Compare the illustrations with your snow thrower to familiarize yourself with the location of various controls and adjustments. Save this manual for future reference.

These symbols may appear on your snow thrower or in literature supplied with the product. Learn and understand their meaning.

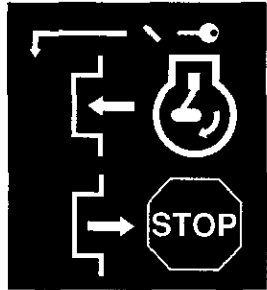
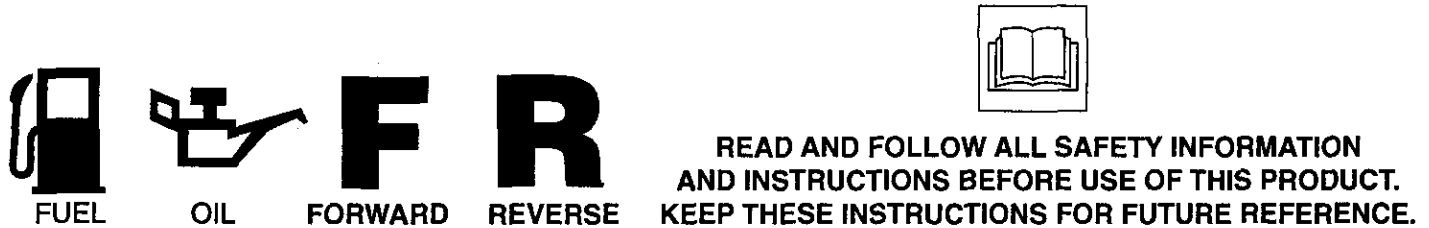

IGNITION KEY.  
INSERT TO START  
AND RUN,  
PULL OUT TO STOP.

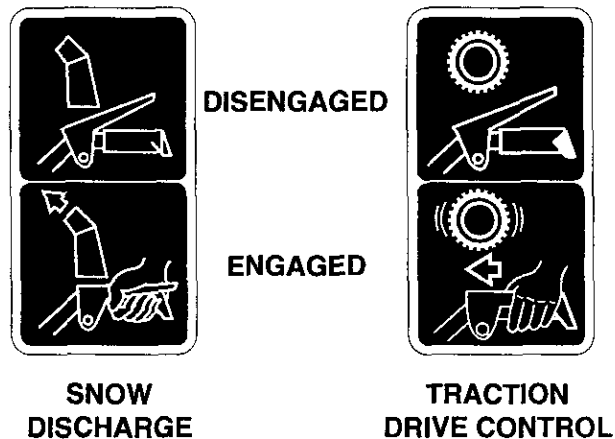

# OPERATION

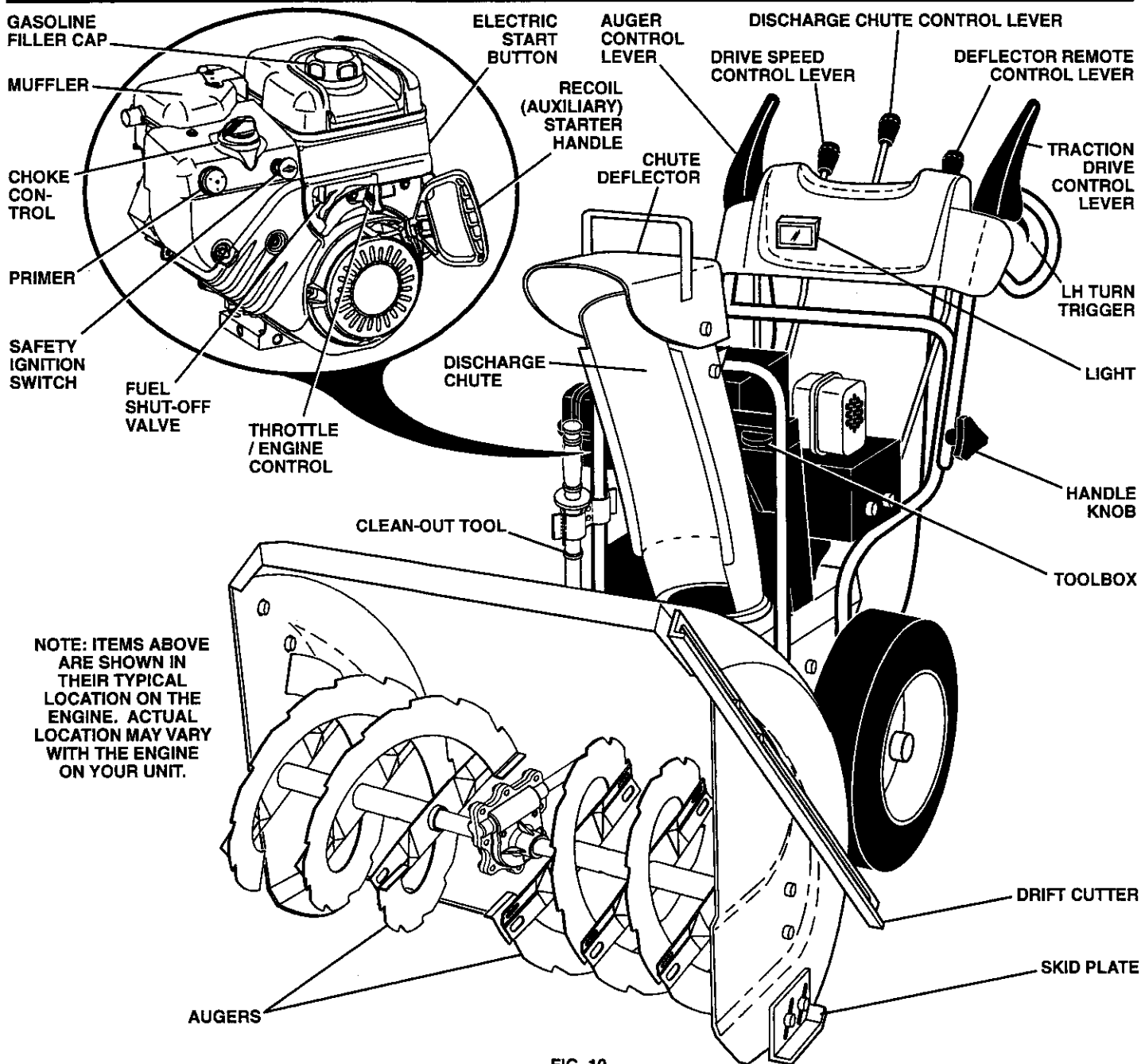

FIG. 10

## MEETS A.N.S.I. SAFETY REQUIREMENTS

Our snow throwers conform to the standards of the American National Standards Institute.

**Toolbox** – used to store spare shear bolts, locknuts and wrench.

**Safety ignition switch** – must be pushed in for the engine to start and run. Pull out when snow thrower is not in use.

**Electric start button** – used for starting the engine.

**Recoil (auxiliary) starter handle** – used for starting engine.

**Primer** – pumps additional fuel from the carburetor to the cylinder for use when starting a cold engine.

**Choke Control** – used for starting a cold engine.

**Throttle / Engine control** – used to select either FAST or SLOW engine speed and to STOP the engine.

**LH and RH turn triggers** – used to steer the snow thrower. 10

**Drive speed control lever** – used to select forward or reverse motion and speed of snow thrower.

**Traction drive control lever** – used to engage power-propelled forward or reverse motion of snow thrower.

**Auger control lever** – used to engage auger motion (throw snow).

**Discharge chute control lever** – used to change the direction the snow is thrown.

**Deflector remote control lever** – used to change the distance the snow is thrown.

**Skid plate** – used to adjust height of scraper bar from ground.

**Drift cutter** – used to cut through deep snowdrifts.

# OPERATION



The operation of any snow thrower can result in foreign objects thrown into the eyes, which can result in severe eye damage. Always wear safety glasses or eye shields while operating your snow thrower or performing any adjustments or repairs. We recommend standard safety glasses or a wide vision safety mask worn over spectacles.

## HOW TO USE YOUR SNOW THROWER

**Know how** to operate all controls before adding fuel or attempting to start the engine.

### STOPPING

#### TRACTION DRIVE

- Release traction drive control lever to stop the forward or reverse movement of the snow thrower.

#### AUGER

- Release the auger control lever to stop throwing snow.

#### ENGINE

1. Move throttle control to "STOP" position.
2. Pull safety ignition switch out to prevent unauthorized use.

**NOTE:** Never use choke to stop engine.

### TO USE FUEL SHUT-OFF VALVE (See Fig. 11)

The fuel shut-off valve is located beneath the fuel tank on the engine. Always operate the snow thrower with the fuel shut-off valve in the OPEN position.

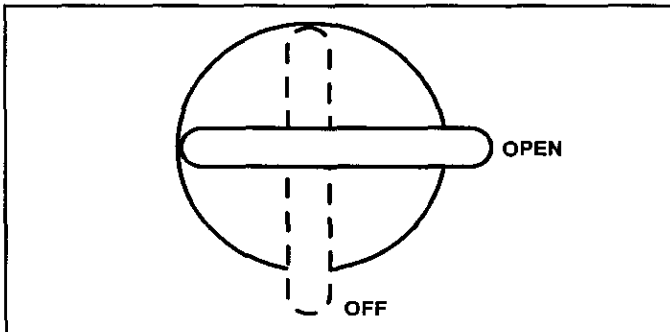

FIG. 11

### TO USE THROTTLE CONTROL (See Fig. 12)

The throttle control is located on the engine. Always operate the snow thrower with the engine at full throttle. Full throttle offers the best snow thrower performance.

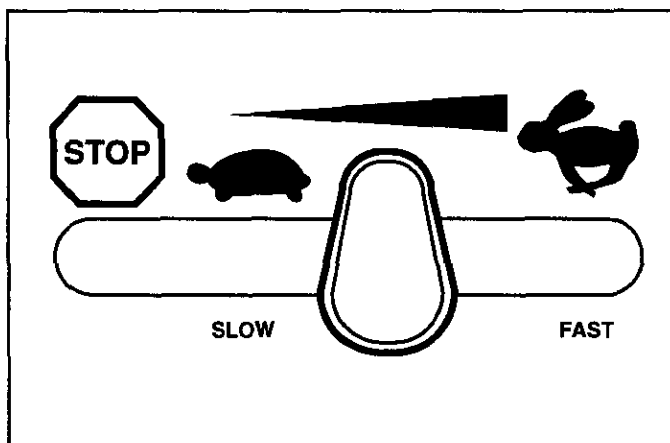

FIG. 12

### TO USE CHOKE CONTROL (See Fig. 13)

The choke control is located on the engine. Use the choke control whenever you are starting a cold engine. Do not use to start a warm engine.

- To engage choke, turn knob clockwise. Slowly turn knob counterclockwise to disengage.

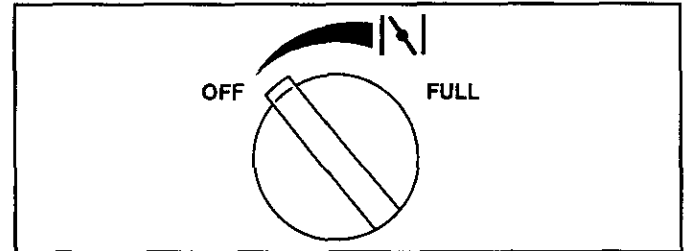

FIG. 13

### TO CONTROL SNOW DISCHARGE (See Fig. 14)



**WARNING:** Snow throwers have exposed rotating parts, which can cause severe injury from contact, or from material thrown from the discharge chute. Keep the area of operation clear of all persons, small children and pets at all times including startup.



**WARNING:** If the discharge chute or auger become clogged, shut-off engine and wait for all moving parts to stop. Use the clean-out tool, NOT YOUR HANDS, to unclog the chute and/or auger.

The **DIRECTION** in which snow is to be thrown is controlled by the discharge chute control lever.

- To change the discharge chute position, press downward on discharge chute control lever and move lever left or right until chute is in desired position. Be sure lever springs back and locks into desired position.

The **DISTANCE** that snow is thrown is controlled by the position of the chute deflector. Set the deflector low to throw snow a short distance; set the deflector higher to throw snow farther.

- Press downward on chute deflector control lever and move lever forward to lower the deflector and decrease the distance. Move lever back to raise the deflector and increase the distance. Be sure lever springs back and locks into desired position.

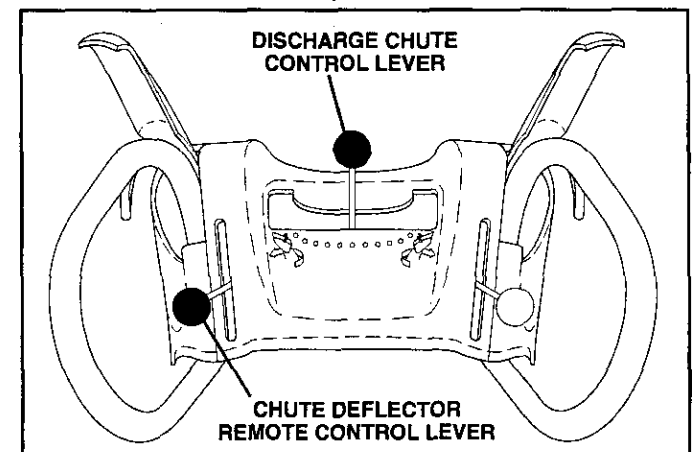

FIG. 14

# OPERATION

## TO THROW SNOW (See Fig. 15)

The auger rotation is controlled by the auger control lever located on the right side handle.

- Squeeze auger control lever to handle to engage the auger and throw snow.
- Release the auger control lever to stop throwing snow.

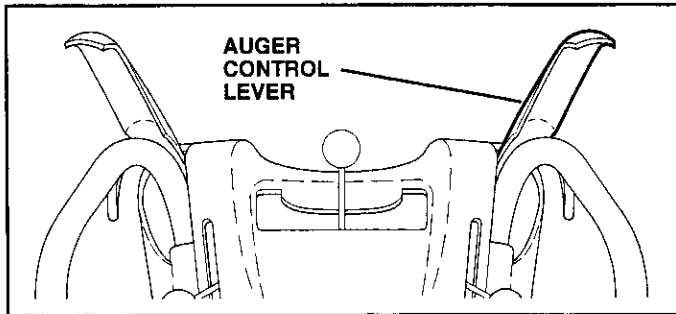

FIG. 15

## USING THE CLEAN-OUT TOOL (See Fig. 16)

In certain snow conditions, the discharge chute may become clogged with ice and snow. Use the clean-out tool to dislodge this blockage.

**When cleaning, repairing, or inspecting, make certain all controls are disengaged and the auger/impeller and all moving parts have stopped. Disconnect the spark plug wire and keep the wire away from the spark plug to prevent accidental starting.**

- Release the auger control lever and shut off the engine.
- Remove the clean-out tool from its mounting clip. Grasp the tool firmly by the handle and push and twist the tool into the discharge chute to dislodge the blockage.

After the packed snow has been dislodged, return the clean-out tool to its mounting clip by pushing it into the clip.

- Make sure the discharge chute is pointed in a safe direction (no vehicles, buildings, people, or other objects are in the direction of discharge) before restarting the engine.
- Restart the engine, then squeeze the auger control lever to the handle to clear snow from the auger housing and the discharge chute.

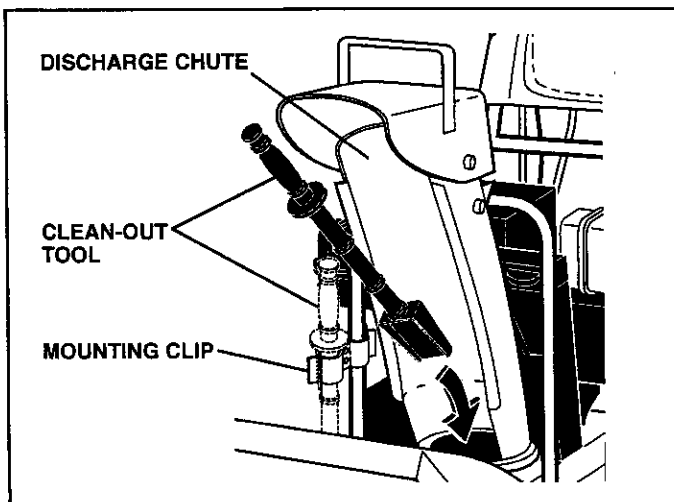

FIG. 16

## TO MOVE FORWARD AND BACKWARD (See Fig. 17)

SELF-PROPELLING, forward and reverse movement of the snow thrower, is controlled by the traction drive control lever located on the left side handle.

- Squeeze traction drive control lever to handle to engage the drive system.
- Release traction drive control lever to stop the forward or reverse movement of the snow thrower.

SPEED and DIRECTION are controlled by the drive speed control lever.

- Press downward on the speed control lever and move lever to desired position BEFORE engaging the traction drive control lever. Be sure lever springs back and locks into desired position.

**CAUTION: Do not move speed control lever when traction drive control lever is engaged. Damage to the snow thrower can result.**

- Slower speeds are for heavier snow and faster speeds are for light snow and transporting the snow thrower. It is recommended that you use a slower speed until you are familiar with the operation of the snow thrower.

**NOTE:** When both traction drive and auger control levers are engaged, the traction drive control lever will lock the auger control lever in the engaged position. This will allow you to release your right hand from the handle and adjust the discharge chute direction without interrupting the snow throwing process.

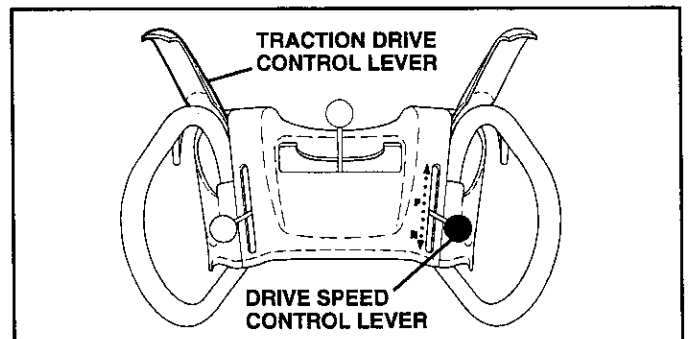

FIG. 17

## POWER STEERING OPERATION (See Fig. 18)

Steering triggers are used to assist in steering your snow thrower. The triggers are located on the underside of each handle. When a trigger is squeezed, it disengages the drive wheel on that side of snow thrower and allows it to turn in that direction.

- To turn left – squeeze left side trigger.
- To turn right – squeeze right side trigger.

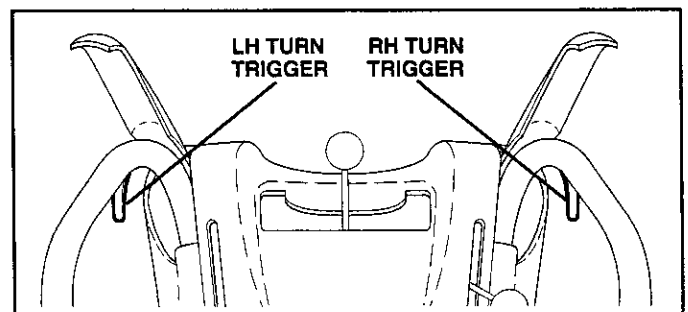

FIG. 18

# OPERATION

## TO ADJUST SKID PLATES (See Fig. 19)

**NOTE:** The wrench provided in your parts bag may be used to adjust the skid plates.

Skid plates are located on each side of the auger housing and adjust the clearance between the scraper bar and the ground surface. Adjust skid plates evenly to proper height for current surface conditions. For removal of snow in normal conditions, such as a paved driveway or sidewalk, place skid plates in the highest position (lowest scraper clearance) to give a 5 mm clearance between the scraper bar and the ground. Use a middle position if the surface to be cleared is uneven.

**NOTE:** It is not recommended to operate the snow thrower over gravel or rocky surfaces. Objects such as gravel, rocks or other debris, can easily be picked up and thrown by the impeller, which can cause serious personal injury, property damage or damage to the snow thrower.

- If snow thrower must be operated over gravel surface, use extra caution and be sure skid plates are adjusted to lowest (highest scraper clearance) position.
1. Shut off engine and wait for all moving parts to stop.
  2. Adjust skid plates by loosening the rear 1/2" hex nut only, then moving skid plate to desired position. Be sure both plates are adjusted evenly. Tighten securely.

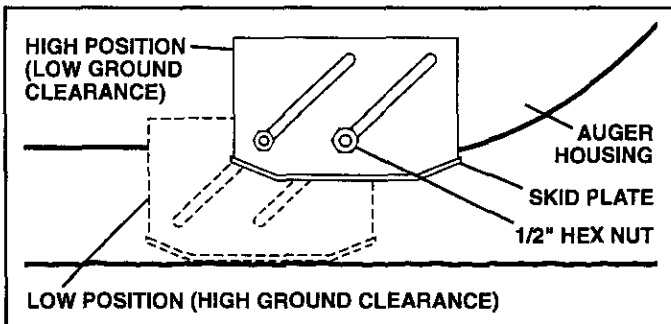

FIG. 19

## SCRAPER BAR

The scraper bar is not adjustable, but is reversible. After considerable use it may become worn. When it has worn almost to the edge of the housing, it can be reversed, providing additional service before requiring replacement. Replace a damaged or worn scraper bar.

## TO USE DRIFT CUTTERS (See Fig. 20)

Use the drift cutters to cut through deep snowdrifts that are higher than the front of the snow thrower.

- Loosen upper adjustment nut enough to allow drift cutter to be raised to highest position and tighten nut securely. Repeat for opposite side of snow thrower.
- When not using drift cutters, loosen adjustment nut, lower to storage position and tighten nut securely.

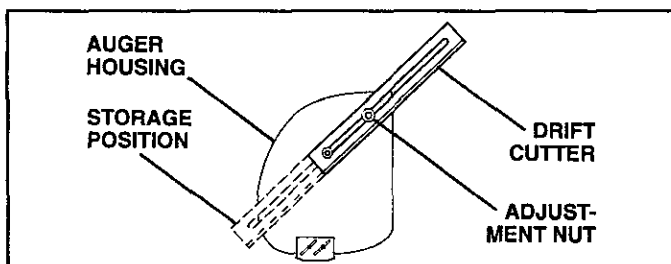

FIG. 20

## BEFORE STARTING THE ENGINE

### CHECK ENGINE OIL LEVEL (See Fig. 21)

The engine on your snow thrower has been shipped, from the factory, already filled with oil.

1. Check engine oil with snow thrower on level ground.
  2. Remove oil fill cap/dipstick and wipe clean, reinsert the dipstick and screw tight, wait for a few seconds, remove and read oil level. If necessary, add oil until "FULL" mark on dipstick is reached. Do not overfill.
- To change engine oil, see "TO CHANGE ENGINE OIL" in the Maintenance section of this manual.

### ADD GASOLINE (See Fig. 21)

- Fill fuel tank to bottom of tank filler neck. Do not overfill. Use fresh, clean, regular unleaded gasoline with a minimum of 87 octane. Do not mix oil with gasoline. Purchase fuel in quantities that can be used within 30 days to assure fuel freshness.



**WARNING:** Wipe off any spilled oil or fuel. Do not store, spill or use gasoline near an open flame.

**CAUTION:** Alcohol blended fuels (called gasohol or using ethanol or methanol) can attract moisture which leads to separation and formation of acids during storage. Acidic gas can damage the fuel system of an engine while in storage. To avoid engine problems, the fuel system should be emptied before storage of 30 days or longer. Empty the gas tank, start the engine and let it run until the fuel lines and carburetor are empty. Use fresh fuel next season. See Storage Instructions for additional information. Never use engine or carburetor cleaner products in the fuel tank or permanent damage may occur.

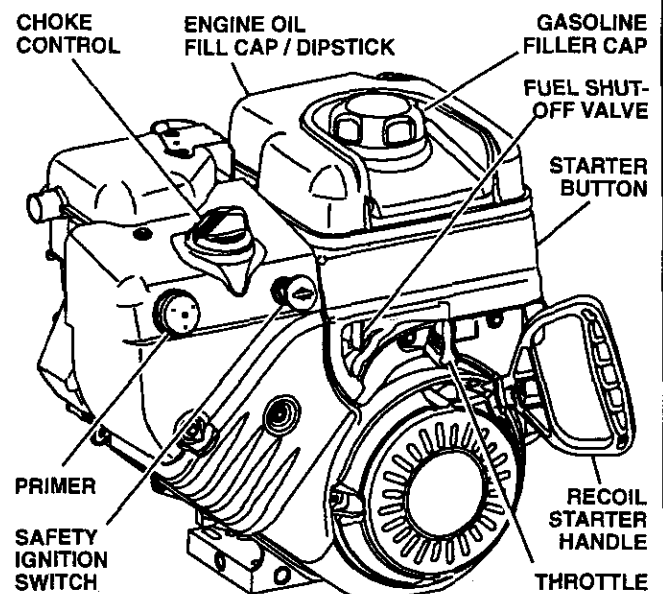

**NOTE:** ALL ITEMS ARE SHOWN IN THEIR TYPICAL LOCATION. ACTUAL LOCATION MAY VARY WITH ENGINE ON YOUR UNIT.

FIG. 21

# OPERATION

## TO START ENGINE

- Be sure fuel shut-off valve is in the OPEN position.

Your snow thrower engine is equipped with both a 120 Volt A.C. electric starter and a recoil starter. The electric starter is equipped with a three-wire power cord and plug and is designed to operate on 120 Volt A.C. household current.

- Be sure your house is a 120 Volt A.C. three-wire grounded system. If you are uncertain, consult a licensed electrician.



**WARNING: Do not use the electric starter if your house is not a 120 Volt A.C. three-wire grounded system. Serious personal injury or damage to your snow thrower could result.**

## COLD START - ELECTRIC STARTER

1. Push safety ignition switch in.
2. Place throttle control in FAST position.
3. Rotate choke control to FULL position.
4. Connect the power cord to the engine.
5. Plug the other end of the power cord into a three-hole grounded 120 Volt A.C. receptacle.

**NOTE:** Do not use primer when starting engine with the electric starter.

6. Push starter button until engine starts.

**IMPORTANT:** Do not crank engine more than five continuous seconds between each time you try to start. Wait 5 to 10 seconds between each attempt.

7. When the engine starts, release the starter button and slowly move the choke control to the OFF position.
8. Disconnect the power cord from the receptacle first, then from the engine.

Allow the engine to warm up for a few minutes. Engine will not develop full power until it has reached normal operating temperature.

## WARM START - ELECTRIC STARTER

Follow the steps above, keeping the choke control in the OFF position.

## COLD START - RECOIL STARTER

1. Push safety ignition switch in.
2. Place throttle control in FAST position.
3. Rotate choke control to FULL position.
4. Push the primer four (4) times if the temperature is below 15°F/-10°C, or two (2) times if temperature is between 15° and 50°F/-10°C and 10°C. If temperature is above 50°F/10°C, priming is not necessary.

**NOTE:** Overpriming may cause flooding, preventing the engine from starting. If you do flood the engine, wait a few minutes before attempting to start and DO NOT push the primer.

5. Pull recoil starter handle quickly. Do not allow starter rope to snap back.
6. When the engine starts, release the recoil starter handle and slowly move the choke control to the OFF position.

Allow the engine to warm up for a few minutes. Engine will not develop full power until it has reached normal operating temperature.

## WARM START - RECOIL STARTER

Follow the steps above, keeping the choke in the OFF position. DO NOT push the primer.

## BEFORE STOPPING

Run the engine for a few minutes to help dry off any moisture on the engine.

To avoid possible freeze-up of the starter, proceed as follows:

## ELECTRIC STARTER

1. Connect the power cord to the engine.
2. Plug the other end of the power cord into a three-hole grounded 120 Volt A.C. receptacle.
3. While the engine is running, push starter button and spin the starter for several seconds.

**NOTE:** The unusual sound made while starter is spinning will not harm the engine or starter.

4. Disconnect the power cord from the receptacle first, then from the engine.

## RECOIL STARTER

1. While the engine is running, pull the recoil starter handle with rapid, full arm strokes three or four times.

**NOTE:** The unusual sound made while pulling the recoil starter handle will not harm the engine or starter.

## IF RECOIL STARTER HAS FROZEN

If the recoil starter has frozen and will not turn the engine, proceed as follows:

1. Grasp the recoil starter handle and slowly pull as much rope out of the starter as possible.
2. Release the recoil starter handle and let it snap back against the starter.

If the engine still fails to start, repeat the above steps or use the electric starter.

## SNOW THROWING TIPS

- Always operate the snow thrower with the engine at full throttle. Full throttle offers the best performance.
- Go slower in deep, freezing or heavy wet snow. Use the drive speed control, NOT the throttle, to adjust speed.
- It is easier and more efficient to remove snow immediately after it falls.
- The best time to remove snow is the early morning. At this time the snow is usually dry and has not been exposed to the direct sun and warming temperatures.
- Slightly overlap each successive path to ensure all snow will be removed.
- Throw snow downwind whenever possible.
- Adjust the skid plates to proper height for current snow conditions. See "TO ADJUST SKID PLATES" in this section of this manual.
- For extremely heavy snow, reduce the width of snow removal by overlapping previous path and moving slowly.
- Keep engine clean and clear of snow during use. This will help air flow and extend engine life.
- After snow-throwing is completed, allow engine to run for a few minutes to melt snow and ice off the engine.
- Clean the entire snow thrower thoroughly after each use and wipe dry so it is ready for next use.



**WARNING:** Do not operate snow thrower if weather conditions impair visibility. Throwing snow during a heavy, windy snowstorm can blind you and be hazardous to the safe operation of the snow thrower.

# MAINTENANCE

## MAINTENANCE SCHEDULE

FILL IN DATES  
AS YOU COMPLETE  
REGULAR SERVICE

BEFORE EACH USE  
AFTER EACH USE  
EVERY 25 HOURS  
OR EVERY SEASON  
EVERY 50 HOURS  
EVERY 100 HOURS  
BEFORE STORAGE

SERVICE  
DATES

	BEFORE EACH USE	AFTER EACH USE	EVERY 25 HOURS OR EVERY SEASON	EVERY 50 HOURS	EVERY 100 HOURS	BEFORE STORAGE	SERVICE DATES
<b>T H R O W E R</b>	Check for Loose Fasteners	✓					
	Clean / Inspect Snow Thrower		✓				
	Check / Replace V-Belts				✓		
	Lubrication Chart			✓		✓	
<b>E N G I N E</b>	Check Engine Oil Level	✓					
	Change Engine Oil			✓			
	Inspect Muffler				✓		
	Check / Replace Spark Plug					✓	
	Empty Fuel Tank						✓

### GENERAL RECOMMENDATIONS

The warranty on this snow thrower does not cover items that have been subjected to operator abuse or negligence. To receive full value from the warranty, operator must maintain snow thrower as instructed in this manual. Some adjustments will need to be made periodically to properly maintain your snow thrower.

At least once a season, check to see if you should make any of the adjustments described in the Service and Adjustments section of this manual.

- At least once a year, you should replace the spark plug and check belts for wear. A new spark plug will help your engine run better and last longer.
- Follow the maintenance schedule in this manual.

**NOTE:** Use only Original Equipment Manufacturer (OEM) parts to service this unit. Failure to do so can cause the unit to malfunction and pose a risk of injury to the operator.

### BEFORE EACH USE

1. Check engine oil level.
2. Check for loose fasteners.
3. Check controls to be sure they are functioning properly.

### LUBRICATION

Keep your snow thrower well lubricated (See "LUBRICATION CHART").

### LUBRICATION CHART

① SAE 5W-30 Motor Oil

② See "ENGINE" in Maintenance section

③ General Purpose Grease

② Engine oil

③ Auger grease fittings

① Pivot points

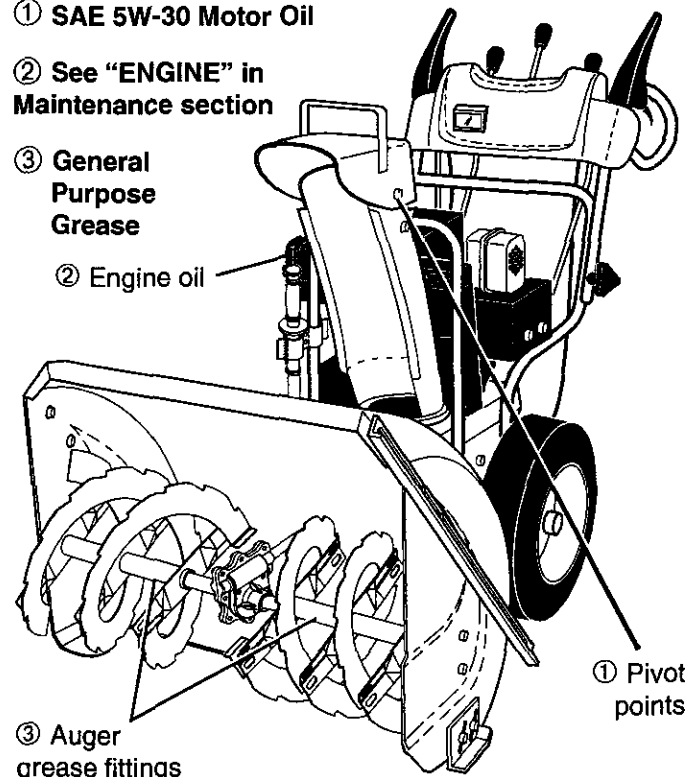

### SNOW THROWER

Always observe the safety rules when performing any maintenance.

### TIRES

- Maintain proper air pressure in both tires (See "PRODUCT SPECIFICATIONS" section in this manual).

- Keep tires free of gasoline and oil, which can harm rubber.

**NOTE:** To seal tire punctures and prevent flat tires due to slow leaks, tire sealant may be purchased from your local parts dealer. Tire sealant also prevents tire dry rot and corrosion.

# MAINTENANCE

## V-BELTS

Check V-belts for deterioration and wear after every 50 hours of operation and replace if necessary. The belts are not adjustable. Replace belts if they begin to slip from wear. (See "TO REMOVE BELT COVER" in the Service and Adjustments section of this manual).

The V-belts on your snow thrower are of special construction and should be replaced by original equipment manufacturer (OEM) belts available from your nearest dealer. Using other than OEM belts can cause personal injury or damage to the snow thrower.

## AUGER GEAR CASE

- The gear case was filled with lubricant to the proper level at the factory. The only time the lubricant needs attention is if service has been performed on the gear case.
- If lubricant is required, use only Ronex ED #1 grease.

## TRACTION DRIVE SYSTEM

DO NOT lubricate the drive components inside the snow thrower. The sprockets, hex shafts, drive disc and friction wheel require no lubrication. The bearings and bushings are lifetime lubricated and require no maintenance.

**CAUTION: Any lubricating of the above components can cause contamination of the friction wheel and damage to the drive system of your snow thrower.**

## ENGINE

### LUBRICATION

Use only high quality detergent oil rated with API service classification SG–SL. Select the oil's SAE viscosity grade according to your expected operating temperature.

SAE VISCOSITY GRADES					
			5W30 or 10W30		
	← Synthetic		5W30 or 10W30		
°F	-20	0	30	32	40
°C	-30	-20	-10	0	10
TEMPERATURE RANGE ANTICIPATED BEFORE NEXT OIL CHANGE					

**NOTE:** Although multi-viscosity oils (5W30, 10W30 etc.) improve starting in cold weather, these multi-viscosity oils will result in increased oil consumption when used above 32°F/0°C. Check your engine oil level more frequently to avoid possible engine damage from running low on oil.

Change the oil after every 25 hours of operation or at least once a year if the snow thrower is not used for 25 hours in one year.

Check the crankcase oil level before starting the engine and after each five (5) hours of continuous use. Tighten oil fill cap / dipstick securely each time you check the oil level.

## TO CHANGE ENGINE OIL

Determine temperature range anticipated before next oil change. All oil must meet API service classification SG–SL.

- Be sure snow thrower is on level surface.
- Oil will drain more freely when warm.
- Catch oil in a suitable container.

**NOTE:** The left side wheel may be removed from snow thrower for easier access to the oil drain plug and placement of a suitable container. The unit tilted, resting on the frame with the left wheel removed, will help drain any oil trapped inside the engine. (See "TO REMOVE WHEELS" in the Service and Adjustments section of this manual).

1. Disconnect spark plug wire from spark plug and place wire where it cannot come in contact with plug.
2. Clean area around drain plug.
3. Remove drain plug and drain oil in a suitable container.
4. Install drain plug and tighten securely.
5. Wipe off any spilled oil from snow thrower and engine.
6. Install left wheel (if removed for draining oil). Be sure to install klick pin into proper hole in wheel axle (See "TO REMOVE WHEELS" in the Service and Adjustments section of this manual).
7. Remove oil fill cap/dipstick. Be careful not to allow dirt to enter the engine.
8. Refill engine with oil through oil dipstick tube. Pour slowly. Do not overfill. For approximate capacity see "PRODUCT SPECIFICATIONS" section of this manual.
9. Use gauge on oil fill cap/dipstick for checking level. Be sure dipstick cap is tightened securely for accurate reading. Keep oil at "FULL" line on dipstick.
10. Wipe off any spilled oil.

## MUFFLER

Inspect and replace corroded muffler as it could create a fire hazard and/or damage.

## SPARK PLUG

Replace spark plug at the beginning of each season or after every 100 hours of operation, whichever occurs first. Spark plug type and gap setting are shown in the "PRODUCT SPECIFICATIONS" section of this manual.

## CLEANING

**IMPORTANT:** For best performance, keep snow thrower housing free of any dirt or trash. Clean the outside of your snow thrower after each use.



**WARNING: Disconnect spark plug wire from spark plug and place wire where it cannot come in contact with plug.**

- Keep finished surfaces/wheels free of gasoline, oil, etc.
- We do not recommend using a garden hose to clean your snow thrower unless the electrical system, muffler and carburetor are covered to keep water out. Water in engine can result in shortened engine life.



# SERVICE AND ADJUSTMENTS

**WARNING:** To avoid serious injury, before performing any service or adjustments:



1. Be sure throttle is in STOP position.
2. Pull safety ignition switch out.
3. Make sure the augers and all moving parts have completely stopped.
4. Disconnect spark plug wire from spark plug and place wire where it cannot come in contact with plug.

## SNOW THROWER

### TO ADJUST SNOW THROWER HEIGHT

See "TO ADJUST SKID PLATES" and "SCRAPER BAR" in the Operation section of this manual.

### CHUTE DEFLECTOR

The chute deflector, attached to the top of the discharge chute, is provided to direct discharging snow away from the operator. If the deflector becomes damaged, it should be replaced.



**WARNING:** To avoid serious injury, never operate your snow thrower with the deflector removed or damaged.

- To change direction and/or distance snow is discharged, see "TO CONTROL SNOW DISCHARGE" in the Operation section of this manual.

### SHEAR BOLTS (See Fig. 22)

#### AUGER SHEAR BOLTS

Both right and left-hand augers are secured to the auger shaft with a shoulder/shear bolt and hex nut. Should a foreign object or ice become lodged in the augers, the shear bolts are designed to break, preventing damage to any other components. If one or both augers do not turn when auger control lever is engaged, check to see if one or both of the bolts have sheared. To replace the shear bolts:

1. Disengage all controls and move throttle control to STOP position. Wait for all moving parts to stop.
2. Disconnect spark plug wire from spark plug and place wire where it cannot come in contact with plug.
3. Align hole in auger hub with hole in auger shaft and install a new 1/4-20 x 2" shoulder/shear bolt. Install 1/4-20 lock nut and tighten securely.

**CAUTION:** Do not substitute. Use only original equipment shear bolts as supplied with your snow thrower.

4. Connect spark plug wire to spark plug.

#### IMPELLER SHEAR BOLTS

The impeller is secured to the impeller shaft with two (2) capscrew/shear bolts and hex nuts. Should a foreign object or ice become lodged in the impeller, the capscrews are designed to break, preventing damage to any other components. If impeller does not turn when auger control lever is engaged, check to see if the capscrews have sheared. To replace the capscrew/shear bolts:

1. Disengage all controls and move throttle control to STOP position. Wait for all moving parts to stop.
2. Disconnect spark plug wire from spark plug and place wire where it cannot come in contact with plug.
3. Align holes in impeller hub with holes in impeller shaft and install two (2) new 1/4-20 x 1-5/8" capscrew/shear bolts. Install 1/4-20 locknuts and tighten securely.

**CAUTION:** Do not substitute. Use only original equipment capscrew/shear bolts as supplied with your snow thrower.

4. Connect spark plug wire to spark plug.

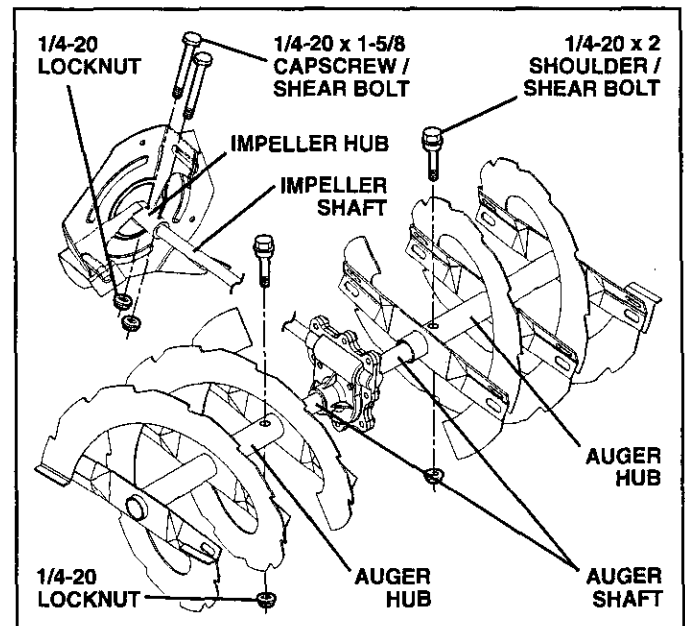

FIG. 22

### TO REMOVE BELT COVER (See Fig. 23)

1. Remove the two (2) screws securing belt cover to frame.
  2. Remove belt cover.
- Replace belt cover by installing cover and screws and tighten securely.

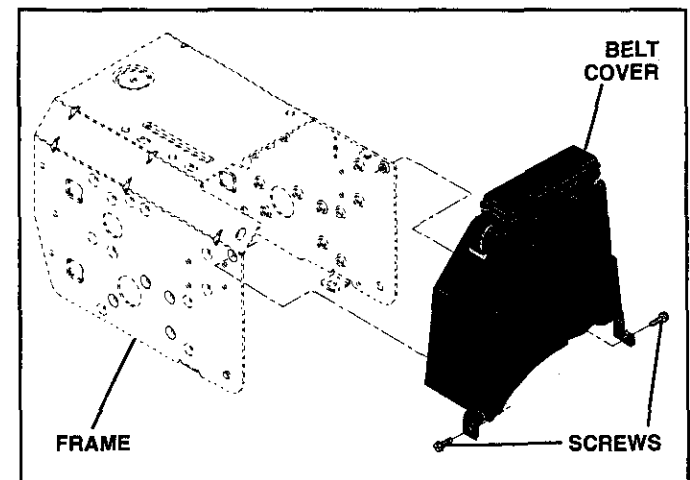

FIG. 23

# SERVICE AND ADJUSTMENTS

## TO REPLACE BELTS (See Fig. 24)

The auger and traction drive belts are not adjustable. If the belts are damaged or begin to slip from wear, they should be replaced. It is recommended that the belt(s) be replaced by a Sears service centre/department.

**NOTE:** It is recommended that both the auger and traction drive belt be replaced at the same time.

The V-belts on your snow thrower are of special construction and should be replaced by original equipment manufacturer (OEM) belts available from your nearest Sears service centre/department. Using other than OEM belts can cause personal injury or damage to the snow thrower.

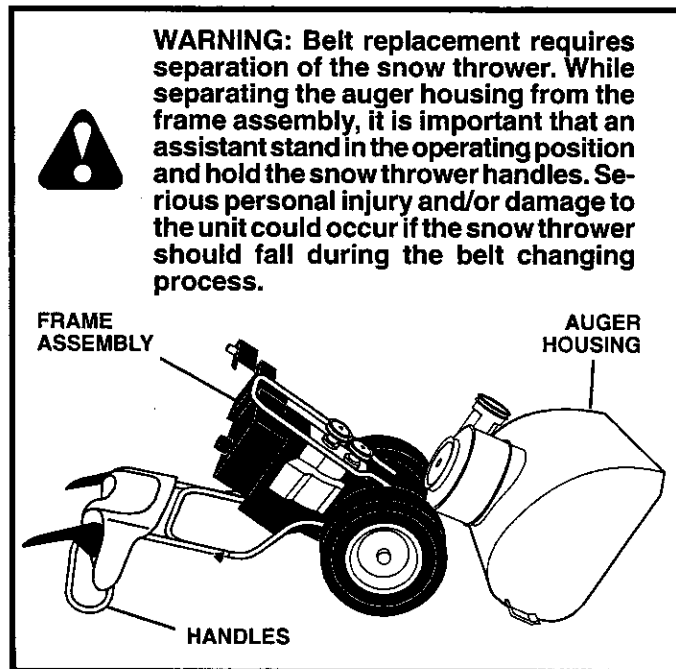

1. REMOVE GASOLINE FROM FUEL TANK - Drain gasoline from fuel tank into a suitable container, outdoors, away from fire or flame. Wipe up any spilled gasoline.
2. REMOVE DISCHARGE CHUTE - Loosen locknut securing chute rotator head to mounting bracket only enough to allow chute rotator head to be raised and discharge chute to be removed from snow thrower.
3. REMOVE BELT COVER - See "TO REMOVE BELT COVER" in this section of this manual.
4. REMOVE ENGINE PULLEY - Remove bolt, lockwasher and flat washer securing pulley to engine crankshaft. Remove outside (auger) pulley only from crankshaft.
5. SEPARATE SNOW THROWER - With your assistant standing in the operating position holding the handles, remove the two (2) bolts and lock washers holding auger housing and frame together.

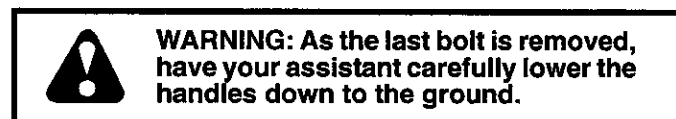

6. REMOVE AUGER BELT from around pulley.
7. RELIEVE TENSION ON TRACTION DRIVE BELT IDLER and remove traction drive belt from around pulleys.

**HINT:** Insert a 3/8" drive ratchet (in the "ON" position) into the square hole in idler arm and rotate ratchet clockwise to relieve tension.

8. With tension relieved on idler, install new traction drive belt around pulleys and inside belt keepers.
9. Place auger belt around and inside the groove of auger pulley only.
10. While your assistant slowly raises handles to rejoin the auger housing and frame assembly, pull up on the auger belt and squeeze sides together above pulley so belt is fully seated in groove of pulley.
11. Bring snow thrower completely together and check carefully for proper routing of belts. If auger belt has become dislodged from the pulley (by catching the idler arm bracket while bringing snow thrower together), separate the snow thrower and repeat step 10. Belt must be fully seated in pulley groove when bringing the snow thrower together.
12. Install the two (2) hex bolts and lock washers and tighten securely.
13. INSTALL ENGINE PULLEY - Place belt in pulley groove and slide pulley on crankshaft. Install flat washer, lockwasher and bolt and tighten securely (41-47 N-m torque). Make sure belt is inside belt keeper.
14. INSTALL BELT COVER and two (2) screws. Tighten securely.
15. INSTALL DISCHARGE CHUTE - See "INSTALL DISCHARGE CHUTE / CHUTE ROTATER HEAD" in the Assembly / Pre-Operation section of this manual.

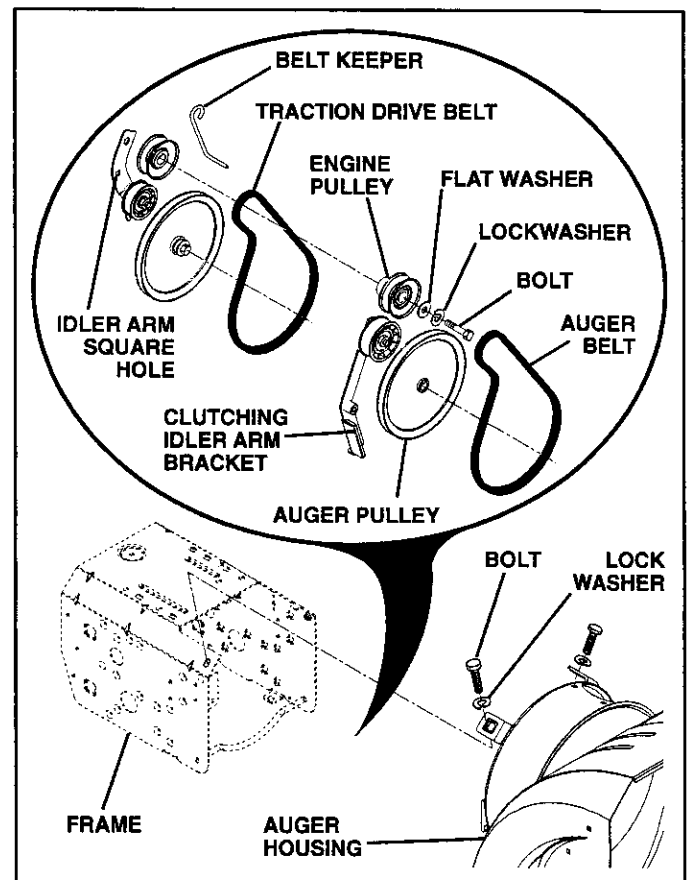

FIG. 24

## TO REMOVE WHEELS (See Fig. 25)

- Remove the klik pin and remove wheel from axle.

**IMPORTANT:** When installing wheel, be sure to use the axle hole closest to the end of the shaft – *do not* use the hole in the wheel hub (if equipped). Inner hole in axle and hole in wheel hub are not used for your model snow thrower.

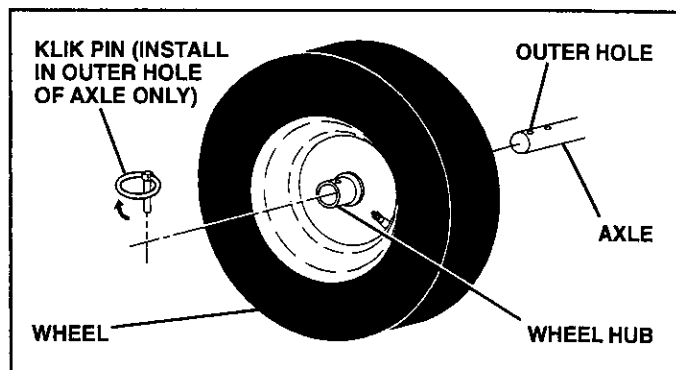

FIG. 25

**NOTE:** To seal punctures or prevent flat tires due to slow leaks, tire sealant may be purchased from your local parts dealer. Tire sealant also prevents tire dry rot and corrosion.

## ENGINE

### CARBURETOR

Your carburetor is not adjustable. Engine performance should not be affected at altitudes up to 2,134 meters. If your engine does not operate properly due to suspected carburetor problems, take your snow thrower to a Sears service centre/department.

### ENGINE SPEED

Never tamper with the engine governor, which is factory set for proper engine speed. Overspeeding the engine above the factory high speed setting can be dangerous and will void the warranty. If you think the engine-governed high speed needs adjusting, contact a Sears service centre/department, which has the proper equipment and experience to make any necessary adjustments.

# STORAGE

Immediately prepare your snow thrower for storage at the end of the season or if the unit will not be used for 30 days or more.



**WARNING:** Never store the snow thrower with gasoline in the tank inside a building where fumes may reach an open flame, spark or pilot light as on a furnace, water heater, clothes dryer or gas appliance. Allow the engine to cool before storing in any enclosure.

## SNOW THROWER

When snow thrower is to be stored for a period of time, clean it thoroughly, remove all dirt, grease, leaves, etc. Store in a clean, dry area.

1. Clean entire snow thrower (See "CLEANING" in the Maintenance section of this manual).
2. Inspect and replace belts, if necessary (See "TO REPLACE BELTS" in the Service and Adjustments section of this manual).
3. Lubricate as shown in the Maintenance section of this manual.
4. Be sure that all nuts, bolts, screws, and pins are securely fastened. Inspect moving parts for damage, breakage and wear. Replace if necessary.
5. Touch up all rusted or chipped paint surfaces; sand lightly before painting.

## ENGINE

### FUEL SYSTEM

**IMPORTANT:** It is important to prevent gum deposits from forming in essential fuel system parts such as carburetor, fuel hose, or tank during storage. Also, alcohol blended fuels (called gasohol or using ethanol or methanol) can attract moisture which leads to separation and formation of acids during storage. Acidic gas can damage the fuel system of an engine while in storage.

- Empty the fuel tank by starting the engine and letting it run until the fuel lines and carburetor are empty.
- Never use engine or carburetor cleaner products in the fuel tank or permanent damage may occur.
- Use fresh fuel next season.

**NOTE:** Fuel stabilizer is an acceptable alternative in minimizing the formation of fuel gum deposits during storage. Add stabilizer to gasoline in fuel tank or storage container. Always follow the mix ratio found on stabilizer container. Run engine at least 10 minutes after adding stabilizer to allow the stabilizer to reach the carburetor. Do not empty the gas tank and carburetor if using fuel stabilizer.

### ENGINE OIL

Drain oil (with engine warm) and replace with clean engine oil. (See "ENGINE" in the Maintenance section of this manual).

### CYLINDER

1. Remove spark plug.
2. Pour approximately one ounce (30 ml) of oil through spark plug hole into cylinder.
3. Pull recoil starter handle slowly a few times to distribute oil.
4. Replace with new spark plug.

### OTHER

- Do not store gasoline from one season to another.
- Replace your gasoline can if your can starts to rust. Rust and/or dirt in your gasoline will cause problems.
- If possible, store your snow thrower indoors and cover it to protect it from dust and dirt.
- Cover your snow thrower with a suitable protective cover that does not retain moisture. Do not use plastic. Plastic cannot breathe, which allows condensation to form and will cause your snow thrower to rust.

**IMPORTANT:** Never cover snow thrower while engine/exhaust area is still warm.

# TROUBLESHOOTING

See appropriate section in manual unless directed to a Sears service centre/department.

PROBLEM	CAUSE	CORRECTION
<b>Does not start</b>	<ol style="list-style-type: none"> <li>1. Fuel shut-off valve (if so equipped) in OFF position.</li> <li>2. Safety ignition switch OUT.</li> <li>3. Out of fuel.</li> <li>4. Throttle in STOP position.</li> <li>5. Choke in OFF position.</li> <li>6. Primer not depressed.</li> <li>7. Engine is flooded.</li> <li>8. Spark plug wire is disconnected.</li> <li>9. Bad spark plug.</li> <li>10. Stale fuel.</li> <li>11. Water in fuel.</li> </ol>	<ol style="list-style-type: none"> <li>1. Turn fuel shut-off valve to OPEN position.</li> <li>2. Push safety ignition switch IN.</li> <li>3. Fill fuel tank with fresh, clean gasoline.</li> <li>4. Move throttle to FAST position.</li> <li>5. Move to FULL position.</li> <li>6. Prime as instructed in the Operation section of this manual.</li> <li>7. Wait a few minutes before restarting, DO NOT prime.</li> <li>8. Connect wire to spark plug.</li> <li>9. Replace spark plug.</li> <li>10. Empty fuel tank &amp; carburetor, refill with fresh, clean gasoline.</li> <li>11. Empty fuel tank &amp; carburetor, refill with fresh, clean gasoline.</li> </ol>
<b>Loss of power</b>	<ol style="list-style-type: none"> <li>1. Spark plug wire loose.</li> <li>2. Throwing too much snow.</li> <li>3. Fuel tank cap is covered with ice or snow.</li> <li>4. Dirty or clogged muffler.</li> </ol>	<ol style="list-style-type: none"> <li>1. Reconnect spark plug wire.</li> <li>2. Reduce speed and width of swath.</li> <li>3. Remove ice and snow on and around fuel tank cap.</li> <li>4. Clean or replace muffler.</li> </ol>
<b>Engine idles or runs roughly</b>	<ol style="list-style-type: none"> <li>1. Choke is in FULL position.</li> <li>2. Blockage in fuel line.</li> <li>3. Stale fuel.</li> <li>4. Water in fuel.</li> <li>5. Carburetor is in need of adjustment or overhaul.</li> </ol>	<ol style="list-style-type: none"> <li>1. Move choke to OFF position.</li> <li>2. Clean fuel line.</li> <li>3. Empty fuel tank &amp; carburetor, refill with fresh, clean gasoline.</li> <li>4. Empty fuel tank &amp; carburetor, refill with fresh, clean gasoline.</li> <li>5. Contact a Sears service centre/department.</li> </ol>
<b>Excessive vibration</b>	<ol style="list-style-type: none"> <li>1. Loose parts or damaged augers or impeller.</li> </ol>	<ol style="list-style-type: none"> <li>1. Tighten all fasteners. Replace damaged parts. If vibration remains, contact a Sears service centre/department.</li> </ol>
<b>Recoil starter is hard to pull</b>	<ol style="list-style-type: none"> <li>1. Frozen recoil starter.</li> </ol>	<ol style="list-style-type: none"> <li>1. See "IF RECOIL STARTER HAS FROZEN" in the Operation section of this manual.</li> </ol>
<b>Loss of traction drive / slowing of drive speed</b>	<ol style="list-style-type: none"> <li>1. Drive belt is worn.</li> <li>2. Drive belt is off of pulley.</li> <li>3. Friction drive wheel is worn.</li> </ol>	<ol style="list-style-type: none"> <li>1. Check / replace drive belt.</li> <li>2. Check / reinstall drive belt.</li> <li>3. Contact a Sears service centre/department.</li> </ol>
<b>Loss of snow discharge or slowing of snow discharge</b>	<ol style="list-style-type: none"> <li>1. Auger belt is off of pulley.</li> <li>2. Auger belt is worn.</li> <li>3. Clogged discharge chute.</li> <li>4. Augers / impeller jammed.</li> </ol>	<ol style="list-style-type: none"> <li>1. Check / reinstall auger belt.</li> <li>2. Check / replace auger belt.</li> <li>3. Clean snow chute.</li> <li>4. Remove debris or foreign object from augers / impeller.</li> </ol>

---

# SERVICE NOTES

---

# REPAIR PARTS

# SNOW THROWER - - MODEL NUMBER 944.524591

## AUGER HOUSING / IMPELLER ASSEMBLY

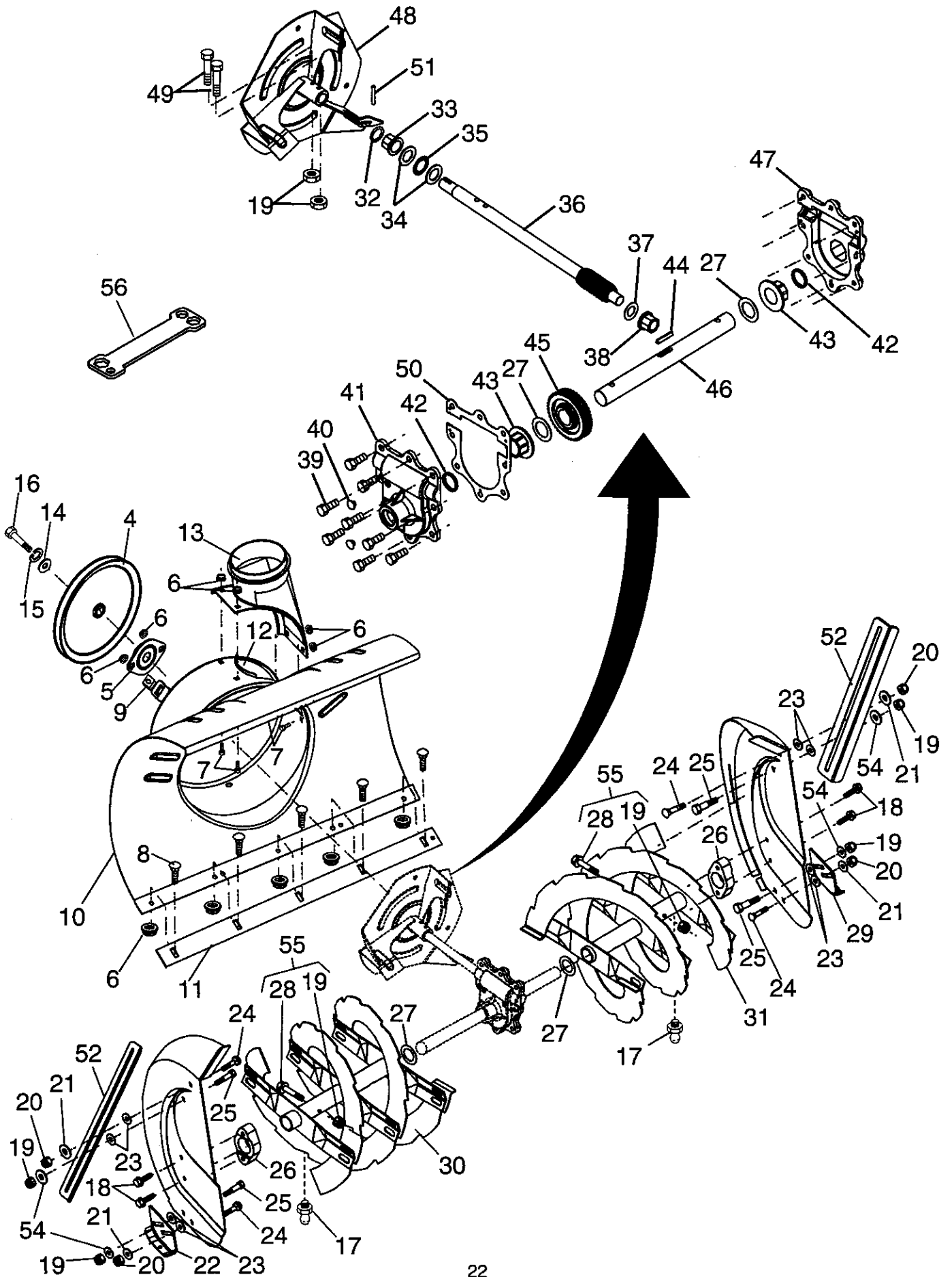

**REPAIR PARTS****SNOW THROWER - - MODEL NUMBER 944.524591****AUGER HOUSING / IMPELLER ASSEMBLY**

KEY NO.	PART NO.	DESCRIPTION
4	191079	Pulley, Impeller
5	188909	Bearing Assembly, Flange
6	155377	Nut, Hex Flange 5/16-18
7	180355	Bolt, Flat Head, Carriage 5/16-18 x 5/8
8	72250505	Bolt, Carriage 5/16-18
9	178820	Nut, Cage 3/8-16
10	178826X615	Housing, Auger
11	178690X479	Bar, Scraper
12	178675X008	Bracket, Corner Discharge
13	175322	Base, Discharge Chute
14	19111507	Washer, Flat
15	10040500	Washer, Lock 5/16
16	74950512	Screw, Hex Head 5/16-18 x 3/4
17	155595	Fitting, Grease
18	179582	Screw, Hex Head 5/16 x 1
19	73800400	Nut, Hex Lock 1/4-20
20	73800500	Nut, Hex Lock 5/16-18
21	155415	Washer, Flat 5/16
22	178777X479	Skid Plate, RH
23	179246	Washer, Nylon, Friction
24	72270506	Bolt, Carriage 5/16-18 x 3/4
25	185600	Bolt, Shoulder 1/4-20
26	174658	Bearing, Auger
27	174697	Washer, Thrust, 1"
28	192090	Bolt, Shear
29	174762X479	Skid Plate, LH
30	198991X479	Auger Assembly, RH
31	198990X479	Auger Assembly, LH
32	174699	O-Ring
33	174700	Bushing, Flange 3/4
34	174681	Washer, Thrust 3/4
35	174684	Bearing, Thrust 3/4
36	174660	Shaft, Impeller
37	174683	Washer, Thrust 5/8
38	174686	Bushing, Flange 5/8
39	150078	Screw, Hex Head 5/16-18 x 3/4
40	86447	Plug, Case
41	174688	Housing, Gearbox, RH
42	174698	Seal, Oil
43	174701	Bushing, Flange, 1"
44	189282	Key, Square 1/4 x 1/4 x 7/8
45	174659	Gear, Worm
46	174657	Shaft, Auger
47	174687	Housing, Gearbox, LH
48	175321X479	Impeller Assembly
49	74780426	Screw, Hex Head 1/4-20 x 1-5/8
50	175311	Gasket, Gearbox
51	7836M	Pin, Roll 3/16 x 1-1/8
52	181160X479	Bar, Drift Cutter
54	53847	Washer, Flat 1/4
55	188243	Kit, Shear (Contains 6 each of Key Numbers 19 and 28)
56	180684	Multi-Wrench

**NOTE:** All component dimensions given in U.S. inches. 1 inch = 25.4 mm  
**IMPORTANT:** Use only Original Equipment Manufacturer (O.E.M.) replacement parts.  
Failure to do so could be hazardous, damage your unit and void your warranty.

# REPAIR PARTS

# SNOW THROWER - - MODEL NUMBER 944.524591

## CONTROL PANEL / DISCHARGE CHUTE

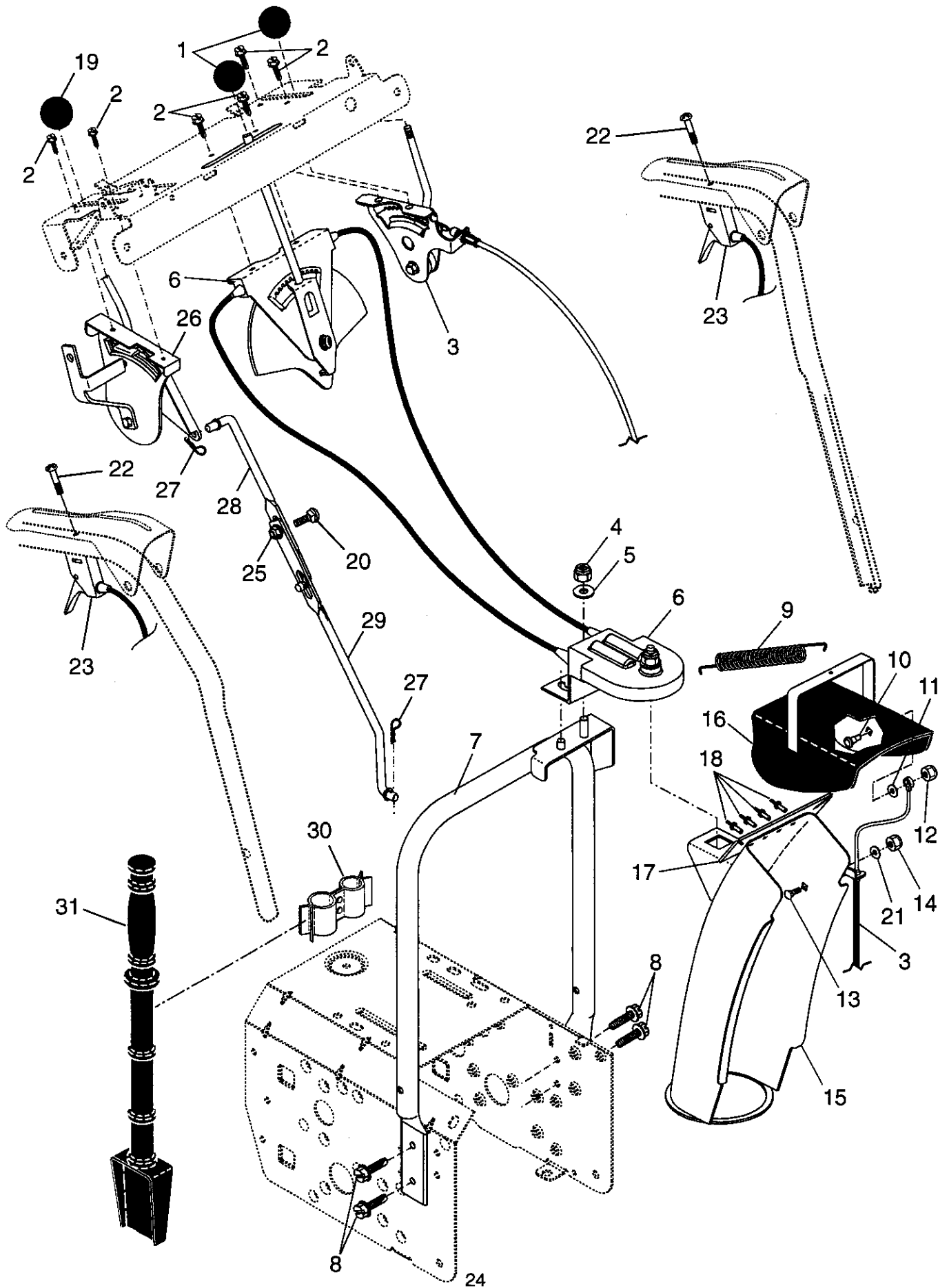



**REPAIR PARTS****SNOW THROWER - - MODEL NUMBER 944.524591****CONTROL PANEL / DISCHARGE CHUTE**

<b>KEY NO.</b>	<b>PART NO.</b>	<b>DESCRIPTION</b>
1	183334	Knob, Lever
2	17501010	Screw #10-24 x 5/8
3	178674	Control Assembly, Deflector
4	73800600	Nut, Lock 3/8-16
5	19131316	Washer, Flat 3/8
6	178659	Control Assembly, Chute Rotater
7	178638X479	Support, Pivot
8	71210616	Screw, Hex Head
9	184505	Spring, Deflector
10	179829	Bolt, Shoulder
11	179246	Washer, Friction, Nylon
12	73800400	Nut, Lock 1/4-20
13	72250505	Bolt, Carriage 5/16-18
14	73800500	Nut, Lock 5/16-18
15	178628X615	Chute Assembly
16	178633X615	Deflector Assembly
17	179145	Seal, Deflector
18	128415	Rivet, Blind
19	183333	Knob, Speed Control Lever
20	72270506	Bolt, Carriage 5/16-18 x 3/4
21	155415	Washer, Flat
22	74041024	Screw #10-24 x 1-1/2
23	188303	Control Assembly, Power Steering
25	155377	Nut, Lock 5/16-18
26	198875	Lever Assembly, Speed Control
27	169675	Retainer, Hairpin
28	180445	Rod, Upper, Speed Control
29	187716	Rod, Lower, Speed Control
30	192710	Clamp, Mounting, Clean-Out Tool
31	192199	Tool, Clean-Out

**NOTE:** All component dimensions given in U.S. inches. 1 inch = 25.4 mm  
**IMPORTANT:** Use only Original Equipment Manufacturer (O.E.M.) replacement parts.  
Failure to do so could be hazardous, damage your unit and void your warranty.

# REPAIR PARTS HANDLES

# SNOW THROWER - - MODEL NUMBER 944.524591

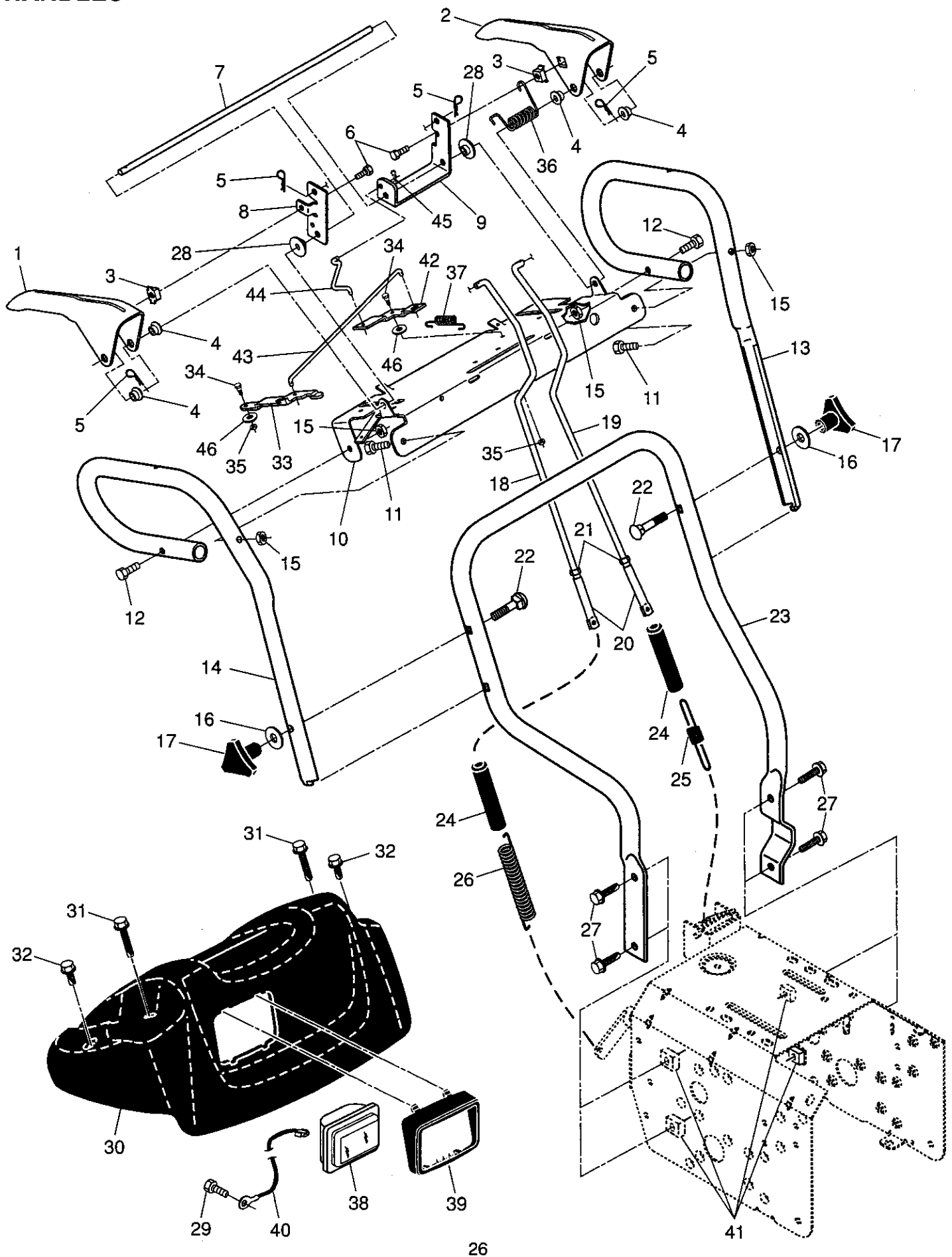

# REPAIR PARTS HANDLES

# SNOW THROWER - - MODEL NUMBER 944.524591

KEY NO.	PART NO.	DESCRIPTION
1	178875X479	Lever, Auger Control, RH
2	178648X479	Lever, Traction Drive Control, LH
3	179439	Nut, Cage 1/4-20
4	178888	Bushing, Flange
5	169675	Retainer, Hairpin
6	180402	Screw, Hex Head 1/4-20 x 3/4
7	178652	Rod, Interlock
8	196333X008	Arm, Impeller Rod
9	196334X008	Arm, Traction Rod
10	196619X479	Panel, Control
11	74780524	Screw, Hex Head 5/16-18 x 1-1/2
12	74780528	Screw, Hex Head 5/16-18 x 1-3/4
13	178646X479	Handle Tube, LH
14	178696X479	Handle Tube, RH
15	73800500	Nut, Lock 5/16-18
16	19131316	Washer, Flat 3/8
17	178899	Knob, Handle
18	184594	Rod, Auger Control
19	193081	Rod, Traction Control
20	180428	End, Control Rod
21	73350500	Nut, Hex, Jam 5/16-18
22	72120618	Bolt, Carriage 3/8-16 x 2-1/4
23	178643X479	Handle Tube, Lower
24	180447	Sleeve, Spring
25	180926	Spring, Traction Drive
26	178669	Spring, Auger Control
27	71210616	Screw, Hex Head 3/8-16 x 1
28	175331	Bushing, Pivot Lever
29	193072	Screw, Headlight Ground Wire to Blower Housing
30	182906	Console, Panel
31	175262	Screw, Hex Head, Tapping #10-24 x 1-1/4
32	184471	Screw, Hex Head, Tapping #10-24 x 1/2
33	196335X008	Latch, Interlock
34	183518	Bolt, Shoulder
35	68038	Nut, Lock 1/4-20
36	178831	Spring, Torsion, Lever
37	193885	Spring, Interlock
38	178666	Headlight, Halogen
39	178668	Bezel, Headlight
40	180964	Harness, Headlight (Halogen)
41	178890	Nut, Cage 3/8-16
42	196336X008	Lever, Interlock
43	196337	Rod, Latch, Interlock
44	196338	Rod, Arm, Interlock
45	700279	Clip
46	179246	Washer, Friction

**NOTE:** All component dimensions given in U.S. inches. 1 inch = 25.4 mm  
**IMPORTANT:** Use only Original Equipment Manufacturer (O.E.M.) replacement parts.  
 Failure to do so could be hazardous, damage your unit and void your warranty.

# REPAIR PARTS

# SNOW THROWER -- MODEL NUMBER 944.524591

## DRIVE

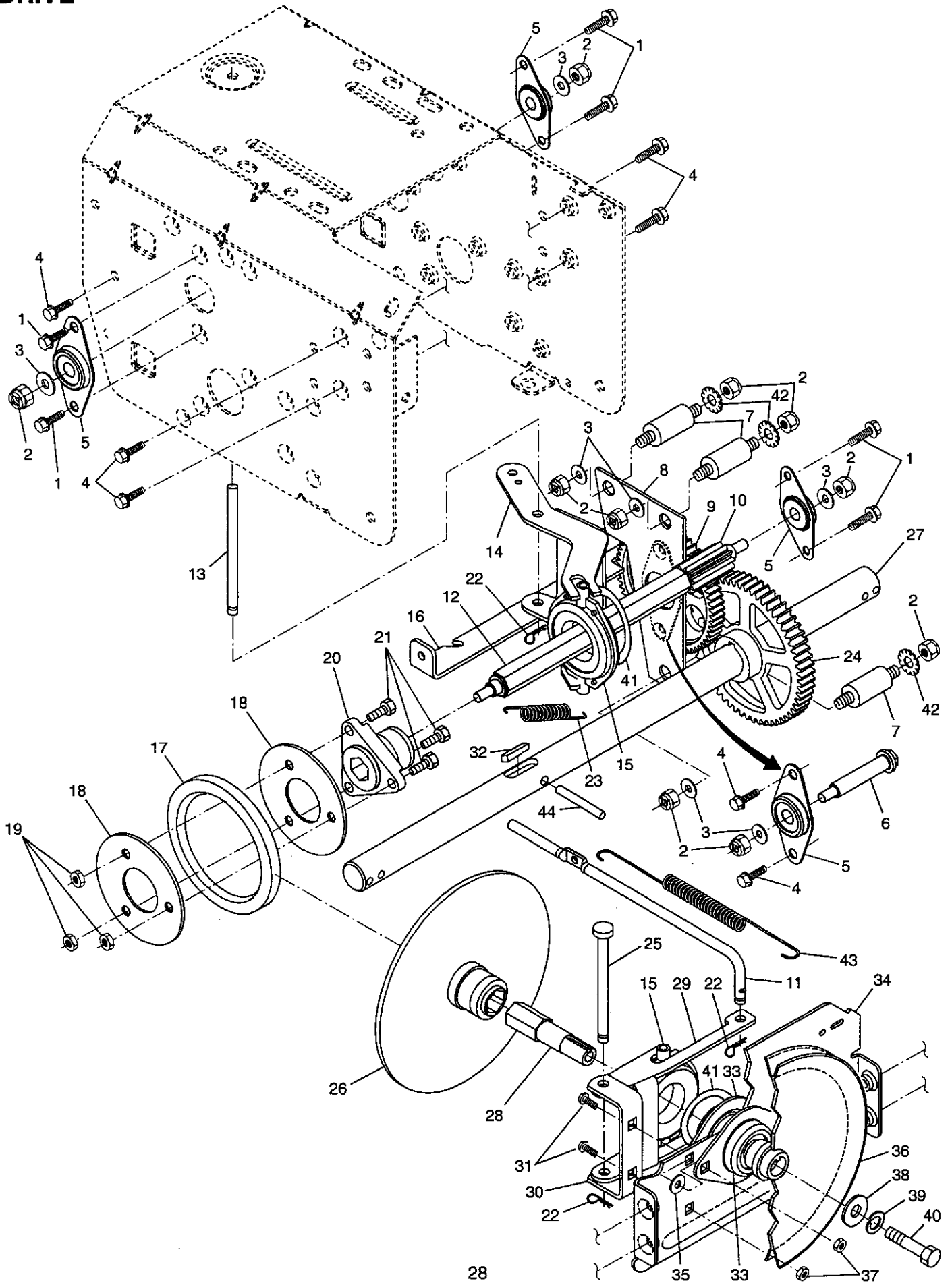

**REPAIR PARTS**  
**DRIVE**

**SNOW THROWER - - MODEL NUMBER 944.524591**

KEY NO.	PART NO.	DESCRIPTION
1	146315	Screw, Hex Head 5/16-18 x 3/4
2	73800500	Nut, Lock 5/16-18
3	155415	Washer, Flat
4	17490508	Screw, Hex Head 5/16-18 x 1/2
5	180017	Bearing, Flange
6	180134	Shaft, Auxiliary
7	179270	Spacer, Plate
8	192616X479	Plate, Auxiliary
9	180082	Gear, Intermediate (12/58)
10	180065	Gear, Pinion
11	187714	Rod, Clutch
12	180066	Shaft, Long, Hex
13	178807	Pin, Pivot
14	178619X479	Lever, Shifter / Wheel
15	175344	Trunnion Bearing Assembly
16	186951X479	Bracket, Pivot, Shifter
17	179831	Ring, Rubber Wheel
18	198176X479	Plate, Rubber Wheel
19	73930500	Nut, Lock 5/16-18
20	178613	Hub, Rubber Wheel
21	74760514	Screw, Hex Head 5/16-18 x 7/8
22	85179	Retainer, Hairpin
23	180135	Spring, Bias
24	180081	Gear, Axle (58 Teeth)
25	178695	Pin, Pivot Lever
26	197763	Plate Assembly, Drive
27	178621	Shaft, Axle
28	197764	Shaft, Short Hex
29	175350X479	Lever, Shifter Plate
30	175349X479	Bracket, Shifter Support
31	72270505	Bolt, Carriage 5/16-18 x 5/8
32	189282	Key, Square 1/4 x 1/4 x 7/8
33	188909	Bearing, Flange
34	175338X479	Plate, Drive Mounting
35	182504	Spacer, Bearing
36	191080	Pulley, Traction Drive
37	155377	Nut, Lock 5/16-18
38	19111507	Washer, Flat
39	10040500	Washer, Lock 5/16
40	74950512	Screw, Hex Head 5/16-18 x 3/4
41	12000012	Ring, Retaining
42	11050500	Washer, Lock, External Tooth 5/16
43	179095	Spring, Return
44	9465M	Pin, Roll

**NOTE:** All component dimensions given in U.S. inches. 1 inch = 25.4 mm  
**IMPORTANT:** Use only Original Equipment Manufacturer (O.E.M.) replacement parts.  
 Failure to do so could be hazardous, damage your unit and void your warranty.

# REPAIR PARTS

# SNOW THROWER - - MODEL NUMBER 944.524591

## CHASSIS / ENGINE / PULLEYS

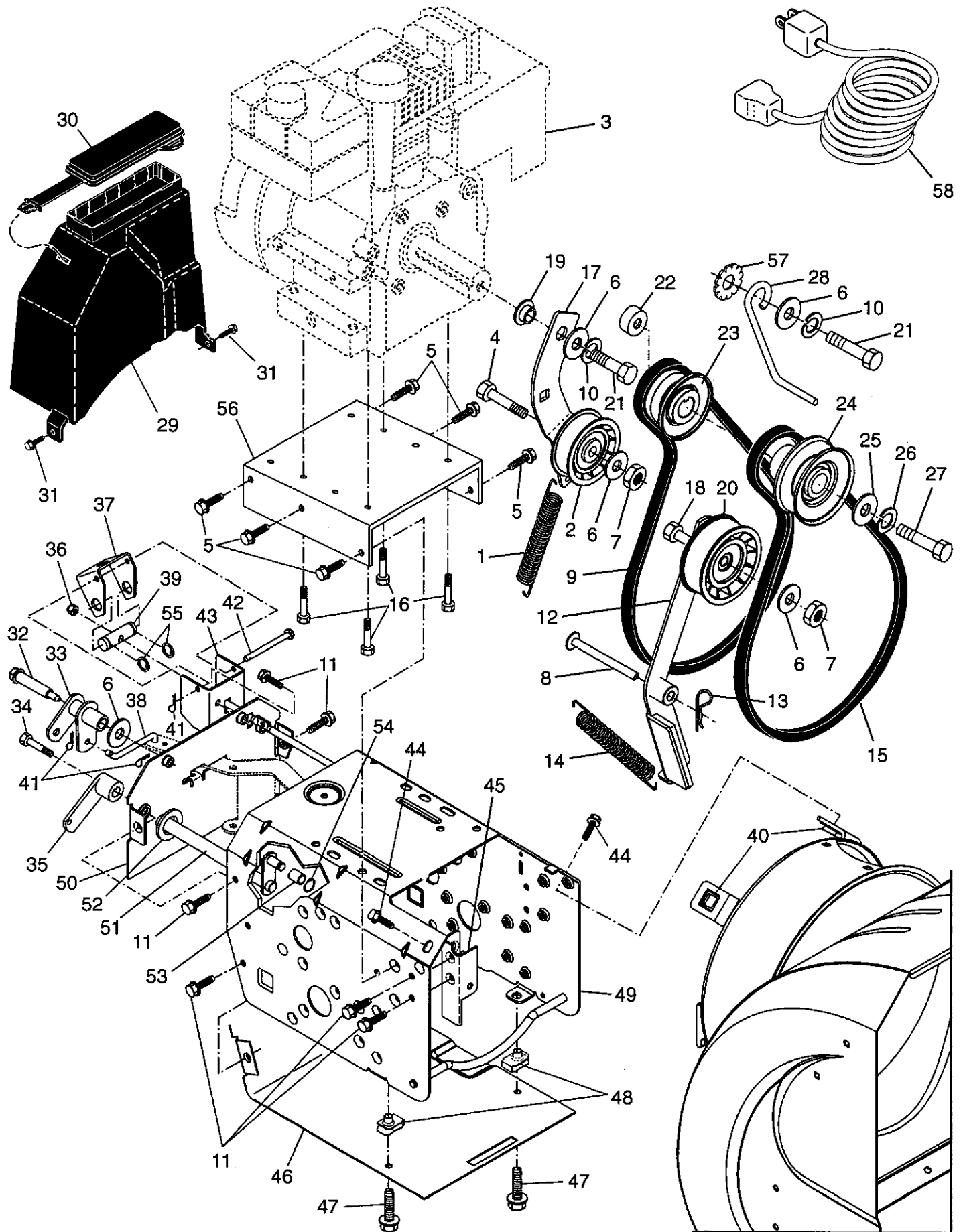

**REPAIR PARTS****SNOW THROWER - - MODEL NUMBER 944.524591****CHASSIS / ENGINE / PULLEYS**

KEY NO.	PART NO.	DESCRIPTION	KEY NO.	PART NO.	DESCRIPTION
1	181044	Spring, Traction Idler	28	155452	Guide, Belt
2	180522	Pulley, Idler (2-1/4)	29	192213	Belt Cover Assembly (Includes Toolbox Cover)
3	---	Engine, Briggs & Stratton, Model Number 20B414-0369-E1 (See Breakdown)	30	178830	Cover, Toolbox
4	74780520	Screw, Hex Head 5/16-18 x 1-1/4	31	17490408	Screw, Hex Head 1/4-20 x 1/2
5	150078	Screw, Hex Washer Head 5/16-18 x 1-1/4	32	179256	Bolt, Shoulder 5/16-18
6	59289	Washer, Flat	33	187853	Bellcrank Shifter
7	73930500	Nut, Jam, Lock 5/16-18	34	180401	Screw, Hex Head 1/4-28 x 3/4
8	175330	Pin, Idler Pivot	35	195767	Arm, Auger Control
9	179092	V-Belt, Traction Drive	36	73800500	Nut, Lock 5/16-18
10	10040500	Washer, Lock 5/16	37	178833X479	Bellcrank
11	17490508	Screw, Hex Washer Head 5/16-18 x 1/2	38	187101	Link, Speed Control
12	179259	Impeller Arm / Pad Assembly	39	192110	Trunnion, Pivot Bracket
13	85179	Retainer, Hairpin	40	178820	Nut, Cage 3/8-16
14	178828	Spring, Brake	41	700279	Clip, Retainer
15	184496	V-Belt, Impeller Drive	42	179065	Pin, Pivot Bracket
16	192306	Screw, Hex Head 3/8-16 x 1-1/4	43	179063X479	Bracket, Bellcrank
17	179354X008	Arm, Idler	44	71210616	Screw, Hex Head 3/8-16
18	74780524	Screw, Hex Head 5/16-18 x 1-1/2	45	175324X479	Bracket, Pivot, Idler
19	175331	Bushing, Idler Pivot	46	178624X479	Pan, Frame Bottom
20	180523	Pulley, Idler (2-3/4)	47	71020512	Screw, Hex Head 5/16-18 x 3/4
21	74610516	Screw, Hex Head 5/16-18 x 1	48	181156	Nut, Speed 5/16-18
22	179371	Spacer, Engine Pulley	49	175336X615	Frame Assembly
23	180478	Pulley, Engine, Traction Drive	50	187715X615	Plate, Frame End
24	179157	Pulley, Engine, Impeller Drive	51	193364X008	Shaft, Auger Control
25	62735	Washer, Flat 3/8	52	57079	Washer, Hardened
26	850263	Washer, Lock 3/8	53	192275	Roller
27	851084	Screw, Hex Head 3/8-24 x 1-3/8	54	192147	Ring, Crescent
			55	12000002	E-Ring
			56	183537X479	Mounting Plate, Engine
			57	11050500	Washer, Lock, External Tooth 5/16
			58	193070	Power Cord

**NOTE:** All component dimensions given in U.S. inches. 1 inch = 25.4 mm  
**IMPORTANT:** Use only Original Equipment Manufacturer (O.E.M.) replacement parts.  
 Failure to do so could be hazardous, damage your unit and void your warranty.

**REPAIR PARTS**  
**WHEELS / DECALS**

**SNOW THROWER - - MODEL NUMBER 944.524591**

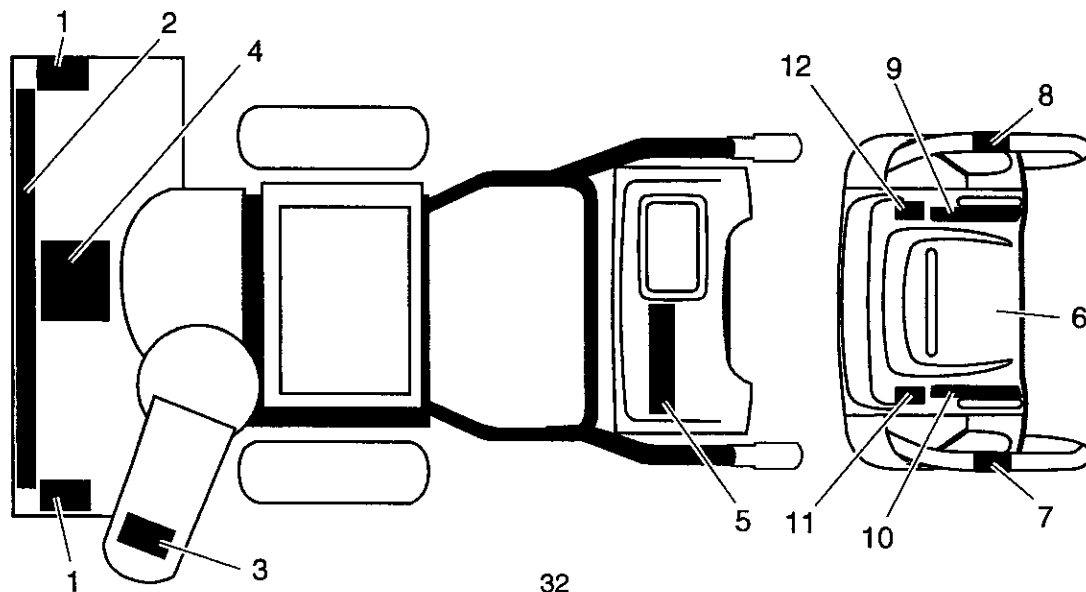
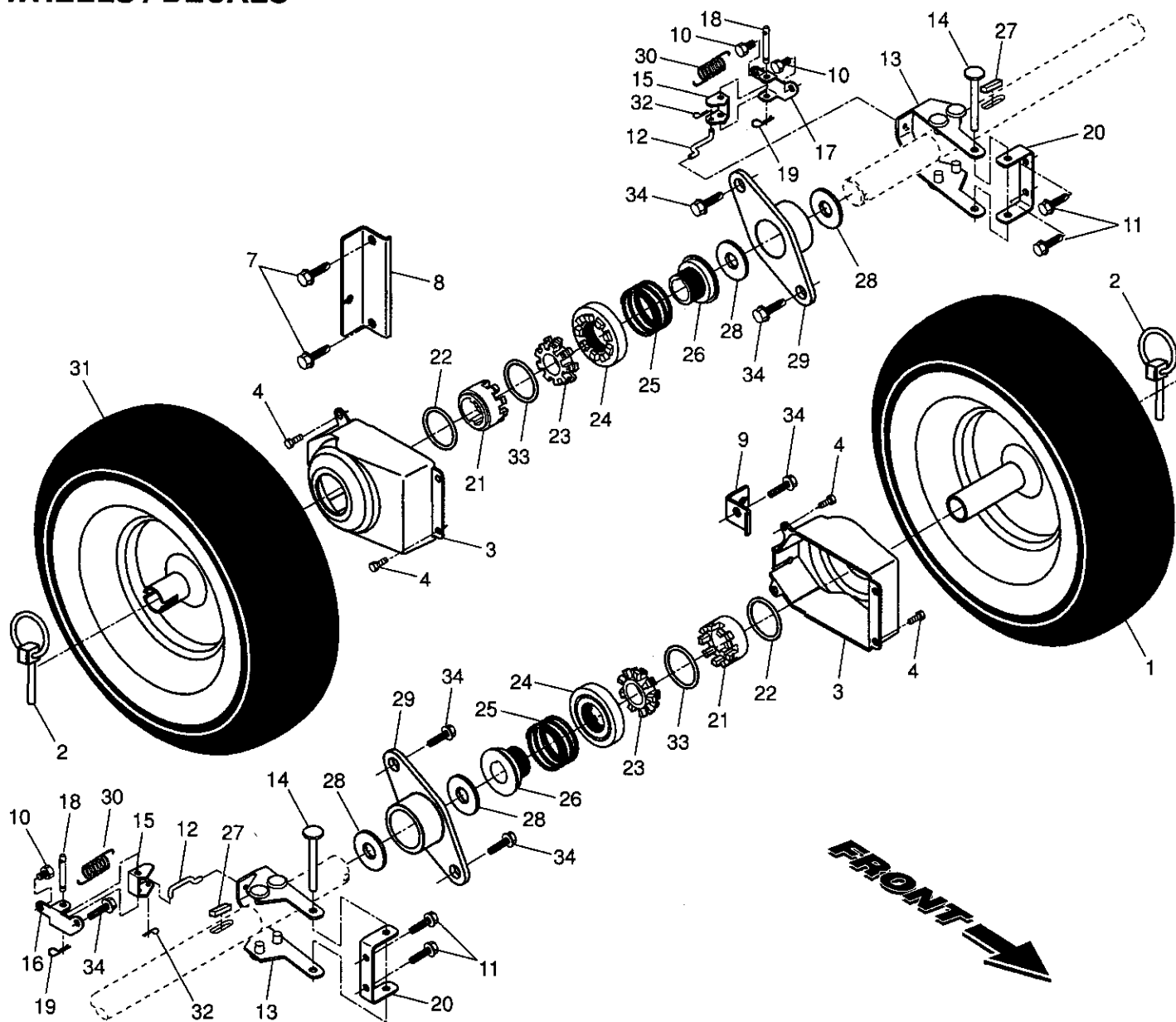



**REPAIR PARTS****SNOW THROWER - - MODEL NUMBER 944.524591****WHEELS / DECALS**

KEY NO.	PART NO.	DESCRIPTION
1	196752X417	Wheel Assembly, 16", Power Steering, LH
2	155443	Pin, Klik 1/4
3	192109	Cover, Power Steering
4	184471	Screw, Hex Head #10-24 x 1/2
7	71210616	Capscrew, Hex Head, Flanged 3/8-16 x 1
8	185603X479	Bracket, Steering Cable, RH
9	185602X479	Bracket, Steering Cable, LH
10	17600406	Screw, Hex Head 1/4-20 x 3/8
11	17490508	Screw, Hex Head 5/16-18 x 1/2
12	195749	Link, Steering Lever
13	193506X498	Yoke, Steering
14	182015	Pin, Steering Lever
15	194944X008	Bellcrank
16	194939X008	Bracket, LH Steering
17	194943X008	Bracket, RH Steering
18	181847	Pin, Steering Bellcrank
19	85179	Retainer, Hairpin
20	179148X479	Bracket, Steering
21	192126	Driver, Wheel
22	182466	Ring, Wire Retainer
23	187622	Lobe, Wheel
24	194941	Slide, Clutch
25	179139	Spring, Clutch Slide
26	194940	Lobe, Axle
27	189282	Key, Square 1/4 x .875
28	174697	Washer, Thrust (1")
29	179830	Bearing, Axle
30	193885	Spring, Return, Steering Latch
31	196753X417	Wheel Assembly, 16", Power Steering, RH
32	700279	Clip, Retainer
33	12000045	Ring, Retaining
34	146315	Screw, Hex Head, Tapping 5/16-18 x 5/8

KEY NO.	PART NO.	DESCRIPTION
1	181037	Decal, Danger
2	192177	Decal, Craftsman, 9.5HP/27"
3	181035	Decal, Danger, Deflector
4	181042	Decal, Danger
5	183876	Decal, Craftsman
6	181033	Decal, Instruction
7	155798	Decal, Traction Lever
8	155800	Decal, Auger Lever
9	181039	Decal, Speed Control
10	183730	Decal, Remote Deflector
11	183907	Decal, LH Trigger
12	183905	Decal, RH Trigger
--	199455	Owner's Manual, English
--	199456	Owner's Manual, French

**NOTE:** All component dimensions given in U.S. inches. 1 inch = 25.4 mm  
**IMPORTANT:** Use only Original Equipment Manufacturer (O.E.M.) replacement parts.  
 Failure to do so could be hazardous, damage your unit and void your warranty.

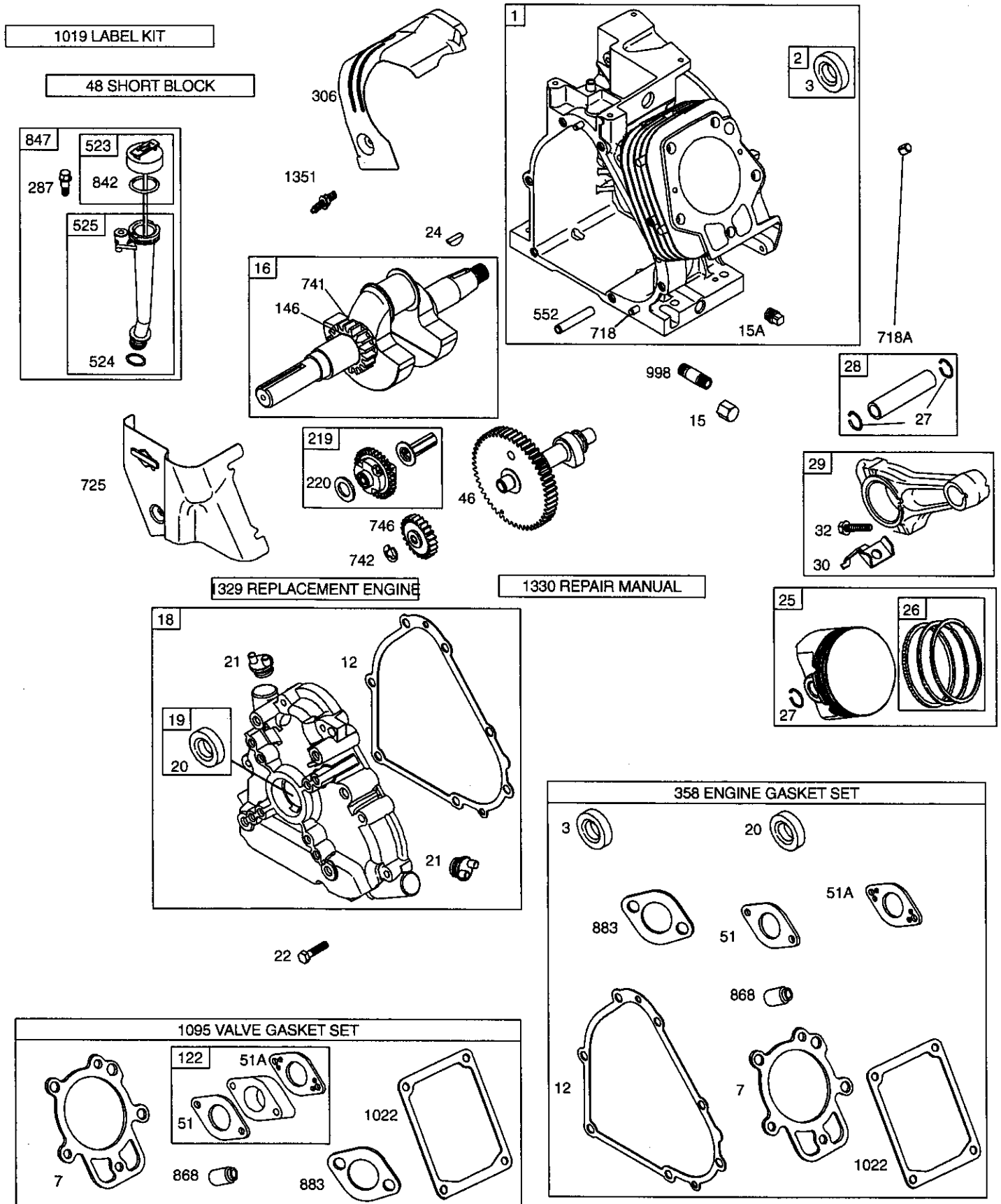

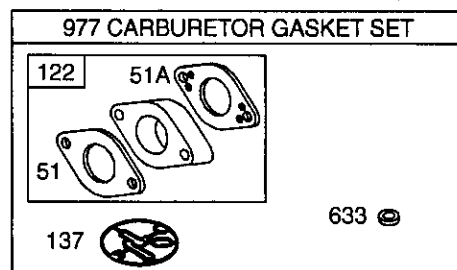
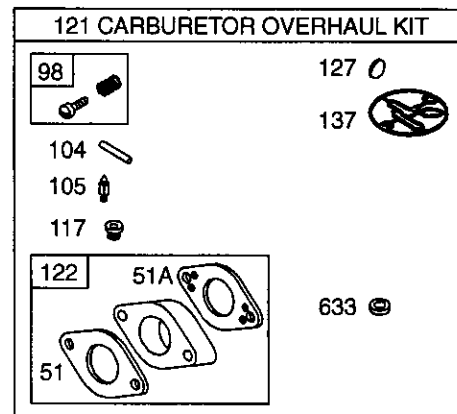
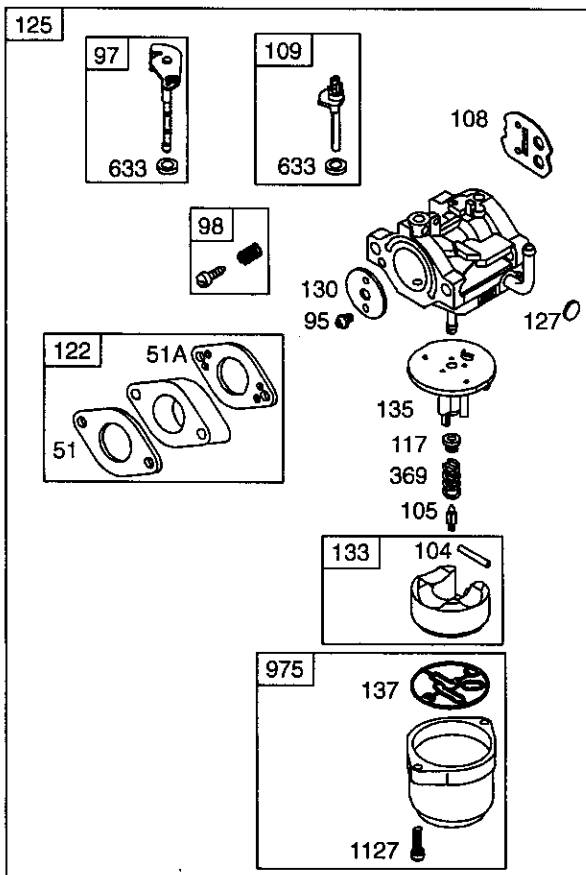
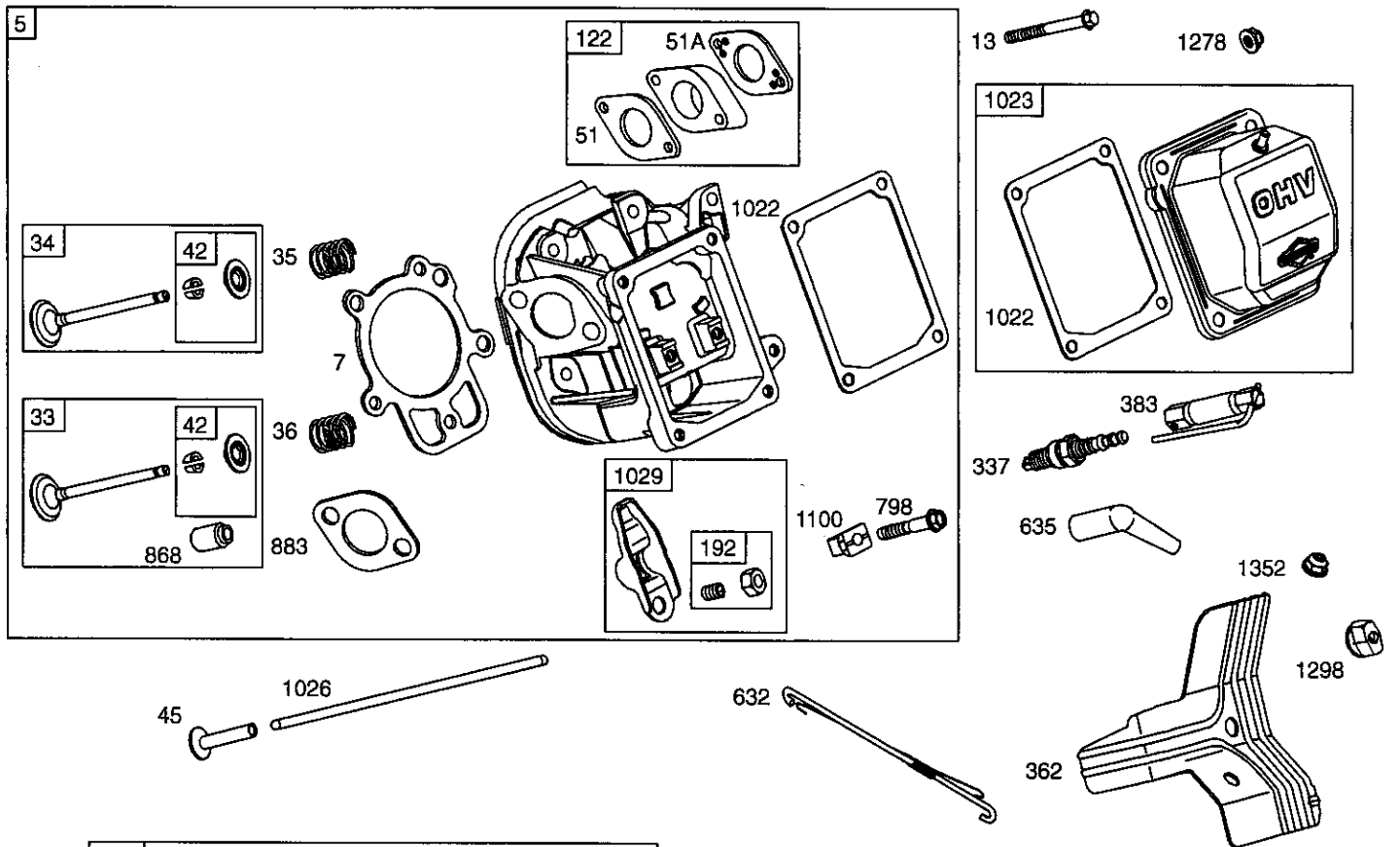

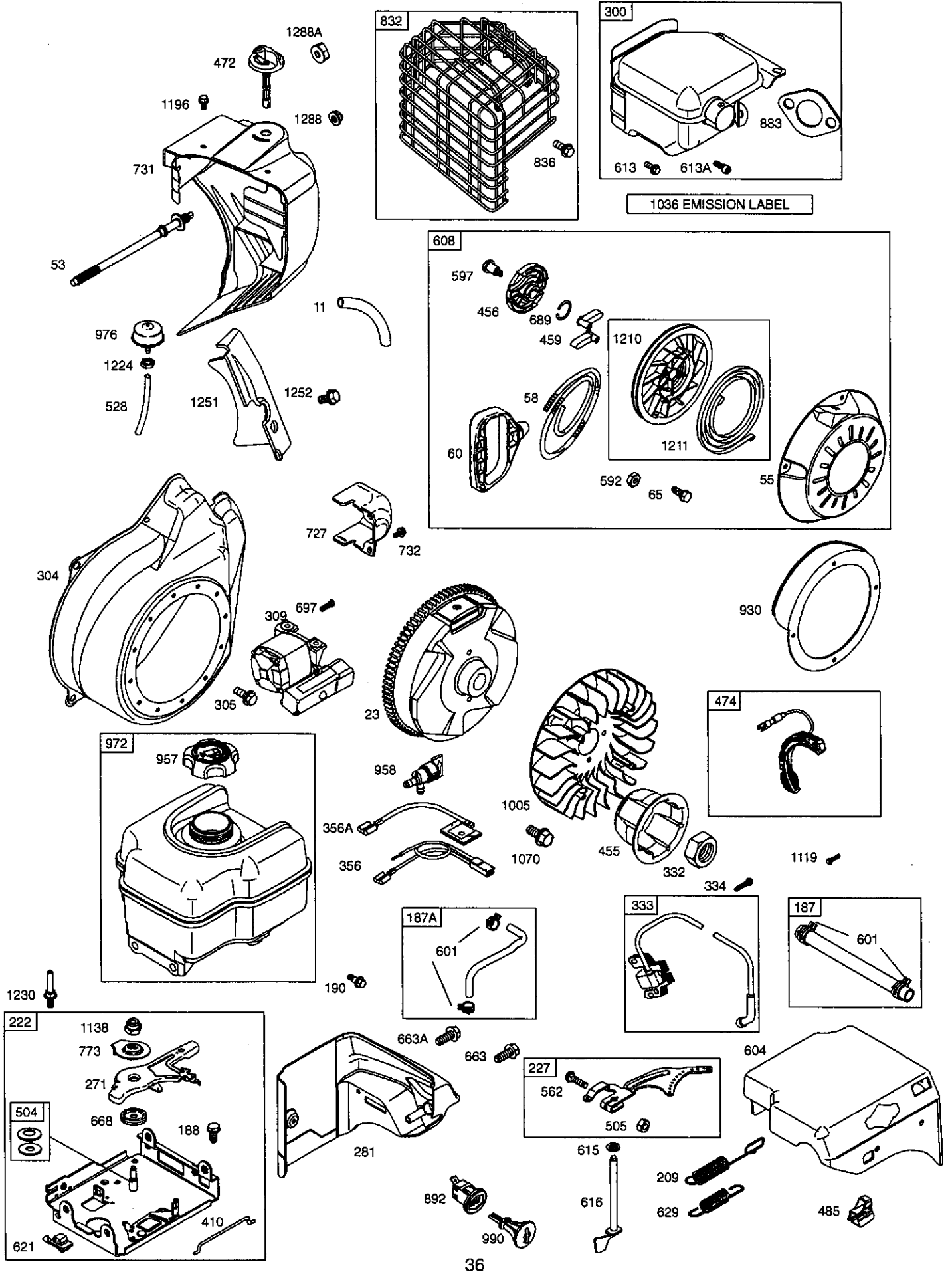

KEY PART NO. NO.	DESCRIPTION	KEY PART NO. NO.	DESCRIPTION
1 696772	Cylinder Assembly	108 696736	Valve-Choke
2 698340	Kit-Bushing/Seal (Magneto Side)	109 696735	Shaft-Choke
3 391086	• Seal-Oil (Magneto Side)	117 696134	Ø Jet-Main (Standard)
5 697233	Head-Cylinder	118 696135	Ø Jet-Main (High Altitude)
7 694872	•+ Gasket-Cylinder Head	121 696146	Kit-Carburetor Overhaul
11 696750	Tube-Breather	122 694876	+ Ø‡ Spacer-Carburetor
12 694953	• Gasket-Crankcase	125 696737	Carburetor
13 690360	Screw (Cylinder Head)	127 690727	Ø Plug-Welch
15 695757	Plug-Oil Drain	130 696139	Valve-Throttle
15A 691686	Plug-Oil Drain	133 694914	Float-Carburetor
16 696412	Crankshaft	135 696142	Tube-Fuel Transfer
18 696914	Cover-Crankcase	137 695426	Ø‡ Gasket-Float Bowl
19 698340	Kit-Bushing/Seal (PTO Side)	146 690979	Key-Timing
20 391086	• Seal-Oil (PTO Side)	187 691050	Line-Fuel (Cut to Required Length)
21 281658	Cap-Oil Fill	187A 695429	Line-Fuel
22 695174	Screw (Crankcase Cover/Sump)	188 690877	Screw (Control Bracket)
23 695485	Flywheel	190 692127	Screw (Fuel Tank)
24 222698	Key-Flywheel	192 690083	Adjuster-Rocker Arm
25 694003	Piston Assembly (Standard)	209 694867	Spring-Governor
694007	Piston Assembly (.020" Oversize)	219 693578	Gear-Governor
26 694004	Ring Set (Standard)	220 691724	Washer (Governor Gear)
694008	Ring Set (.020" Oversize)	222 698034	Bracket-Control
27 690975	Lock-Piston Pin	227 694864	Lever-Governor Control
28 690229	Pin-Piston	271 698035	Lever-Control
29 694691	Rod-Connecting	281 697400	Panel-Control
30 694692	Dipper-Connecting Rod	287 691693	Screw (Dipstick Tube)
32 690976	Screw (Connecting Rod)	300 699222	Muffler
33 499596	Valve-Exhaust	304 697469	Housing-Blower
34 697464	Valve-Intake	305 691108	Screw (Blower Housing)
35 694865	Spring-Valve (Intake)	306 697240	Shield-Cylinder
36 694865	Spring-Valve (Exhaust)	309 698112	Motor-Starter
42 499586	Keeper-Valve	332 694685	Nut (Flywheel)
45 690977	Tappet-Valve	333 715231	Armature-Magneto
46 790496	Camshaft	334 691061	Screw (Magneto Armature)
48 - - -	Short Block	337 491055	Plug-Spark
51 694874	•+Ø‡ Gasket-Intake	356 696700	Wire-Stop
51A 694875	•+Ø‡ Gasket-Intake	356A 696748	Wire-Stop
53 696753	Stud (Carburetor)	358 695438	Gasket Set-Engine
55 696710	Housing-Rewind Starter	362 698041	Shield-Spark Plug
58 693389	Rope-Starter (Cut to Length)	369 695422	Spring-Float Bowl
60 695740	Grip-Starter Rope	383 19374	Wrench-Spark Plug
65 690837	Screw (Rewind Starter)	410 695382	Link-Control
95 690718	Screw (Throttle Valve)	455 697226	Cup-Flywheel
97 696387	Shaft-Throttle	456 692299	Plate-Pawl Friction
98 695408	Ø Kit-Idle Speed	459 281505	Pawl-Ratchet
104 694918	Ø Pin-Float Hinge	472 696752	Knob-Choke Shaft
105 696136	Ø Valve-Float Needle	474 694457	Alternator

KEY PART NO. NO.	DESCRIPTION	KEY PART NO. NO.	DESCRIPTION
485 695755	Knob-Control	957 695737	Cap-Fuel
504 695383	Washer Set-Friction	958 698180	Valve-Fuel Shut Off
505 691251	Nut (Governor Control Lever)	972 695728	Tank-Fuel
523 695344	Dipstick	975 696138	Bowl-Float
524 691876	Seal-O Ring (Dipstick Tube)	976 790221	Primer-Carburetor
525 695343	Tube-Dipstick	977 696147	Gasket Set-Carburetor
528 696751	Hose-Primer	990 695756	Key Set
552 694674	Bushing-Governor Crank	998 696683	Pipe-Oil
562 691119	Bolt (Governor Control Lever)	1005 694684	Fan-Flywheel
592 690800	Nut (Rewind Starter)	1019 790459	Kit-Label
597 691696	Screw (Pawl Friction Plate)	1022 690971	•+ Gasket-Rocker Cover
601 95162	Clamp-Hose	1023 698042	Cover-Rocker
604 696758	Cover-Control	1026 695177	Rod-Push
608 699335	Starter-Rewind	1029 690972	Arm-Rocker
613 695312	Screw (Muffler)	1036 698179	Label-Emissions
613A 696705	Screw (Muffler)	1070 691058	Screw (Flywheel Fan)
615 694676	Retainer-Governor Shaft	1095 695440	Gasket Set-Valve
616 694675	Crank-Governor	1100 690973	Pivot-Rocker Arm
621 692310	Switch-Stop	1119 691183	Screw (Alternator)
629 695307	Spring-Throttle Return	1127 695407	Screw (Float Bowl)
632 695917	Spring/Link-Mechanical Governor	1138 694255	Nut (Control Bracket)
633 690998	Ø‡ Seal-Choke/Throttle Shaft	1171 696754	Stud (Rocker Arm Cover)
635 710901	Boot-Spark Plug	1196 696692	Screw (Snow Hood)
663 696685	Screw (Control Panel)	1210 498144	Pulley / Spring Assembly (Pulley)
663A 696704	Screw (Control Panel)	1211 498144	Pulley / Spring Assembly (Spring)
668 694257	Spacer(Control Bracket)	1224 696824	Nut (Carburetor Primer)
689 691855	Spring-Friction	1230 696747	Stud (Control Bracket)
697 698113	Screw (Starter Motor)	1251 696762	Shield-Snow
718 690959	Pin-Locating	1252 696763	Screw (Snow Shield)
718A 695178	Pin-Locating	1278 696757	Nut (Rocker Cover)
725 696756	Shield-Heat	1288 696757	Nut (Snow Hood)
727 697465	Cover-Starter Drive	1288A 698111	Nut (Snow Hood)
731 790222	Hood-Snow	1298 698111	Knob-Snow Hood
732 691097	Screw (Starter Drive Cover)	1329 20B414-0017	Replacement Engine
741 691288	Gear-Timing	1330 272147	Repair Manual
742 692564	Retainer-E Ring	1351 790017	Stud (Cylinder Shield)
746 694679	Gear-Idler	1352 790026	Nut (Spark Plug Shield)
773 694258	Retainer		
798 697890	Screw (Rocker Cover)		• Included in Engine Gasket Set, Key No. 358
832 699223	Guard-Muffler		Ø Included in Carburetor Overhaul Kit, Key No. 121
836 691003	Screw (Muffler Guard)		‡ Included in Carburetor Gasket Set, Key No. 977
842 691031	Seal-O Ring (Dipstick)		+ Included in Valve Gasket Set, Key No. 1095
847 695342	Dipstick/Tube Assembly		
868 690968	•+ Seal-Valve		
883 695398	•+ Gasket-Exhaust		
892 696749	Switch-Key		
930 696709	Guard-Rewind		

**NOTE:** All component dimensions given in U.S. inches  
1 inch = 25.4 mm

## SERVICE NOTES

# Get it fixed, at your home or ours!

Just Call:

**1-800-4-MY-HOME®**

(1-800-469-4663)

24 hours a day, 7 days a week

For the repair of major brand appliances **in your own home...**  
no matter who made it, no matter who sold it!

For your nearest **Sears Parts and Service** location,  
to bring in products like vacuums, lawn equipment and electronics.

For **Sears Parts & Service**, to order the replacement parts,  
accessories and owner's manuals that you need to do-it-yourself.

[www.sears.ca](http://www.sears.ca)

---

To purchase or inquire about a Sears Maintenance Agreement, call:

**1-800-361-6665**

9 a.m. – 11 p.m. Mon. – Fri., EST, 9 a.m. – 4 p.m. Sat.

---

Pour service en français:

**1-800-LE-FOYER<sup>MC</sup>**

(1-800-533-6937)

[www.sears.ca](http://www.sears.ca)



02488e

® / ™ Trademarks of Sears, Roebuck and Co. used under license by Sears Canada

<sup>MD</sup> Marque déposée / <sup>MC</sup> Marque de commerce de Sears, Roebuck and Co. utilisée en vertu d'une licence de Sears Canada



## Free Manuals Download Website

<http://myh66.com>

<http://usermanuals.us>

<http://www.somanuals.com>

<http://www.4manuals.cc>

<http://www.manual-lib.com>

<http://www.404manual.com>

<http://www.luxmanual.com>

<http://aubethermostatmanual.com>

Golf course search by state

<http://golfingnear.com>

Email search by domain

<http://emailbydomain.com>

Auto manuals search

<http://auto.somanuals.com>

TV manuals search

<http://tv.somanuals.com>