

ASSEMBLY

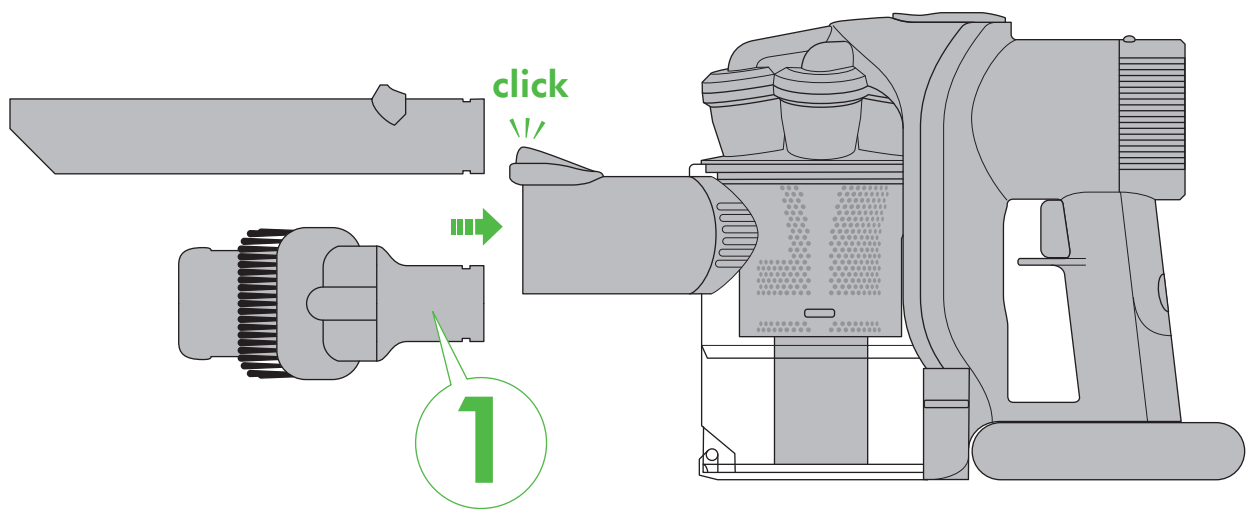

WASH FILTER
Wash your filter with cold water regularly or as required.

12 1 2 3 4 5 6 7 8 9 10 11

3.5 hrs

FULLY CHARGED

**REGISTER
YOUR DYSON
2 YEAR
GUARANTEE
TODAY**

MAX

Your Dyson vacuum cleaner will be covered for parts and labour for 2 years from the date of purchase, as detailed in the terms of the Dyson guarantee on page 9 of this Dyson Operating Manual.

If you have a query about your Dyson vacuum cleaner, call the Dyson Customer Care Helpline with your serial number and details of where and when you bought the vacuum cleaner. Your serial number can be found on the main body of the vacuum cleaner behind the filter.

Most queries can be solved over the phone by one of our Dyson Customer Care Helpline staff (details below).

Visit our website to register your Dyson full parts and labour guarantee online (Australia and New Zealand only).

AU: www.dyson.com.au/register

NZ: www.dyson.co.nz/register

Note your serial number for future reference



This illustration is for example purposes only.

3 EASY WAYS TO REGISTER YOUR DYSON 2 YEAR GUARANTEE



**REGISTER
ONLINE**

Visit our website to register your Dyson full parts and labour guarantee online (Australia and New Zealand only).

AU: www.dyson.com.au/register
NZ: www.dyson.co.nz/register



**REGISTER
BY PHONE**

Call our dedicated Helpline.

AU 1800 239 766
NZ 0800 397 667
SG 7000 435 7546
ID 021 707 39766



**REGISTER
BY MAIL**

Complete and return the form to Dyson in the envelope supplied.

IMPORTANT SAFETY INSTRUCTIONS

BEFORE CHARGING THE BATTERY OR USING THIS APPLIANCE, READ ALL INSTRUCTIONS AND CAUTIONARY MARKINGS IN THIS MANUAL, ON THE CHARGER, ON THE BATTERY AND ON THE DYSON VACUUM CLEANER.

When using an electrical appliance, basic precautions should always be followed, including the following:

WARNING

TO REDUCE THE RISK OF FIRE, ELECTRIC SHOCK, OR INJURY:

1. This Dyson vacuum cleaner and charger are not intended for use by young children or infirm persons with reduced physical, sensory or reasoning capabilities, or lack of experience and knowledge, unless they have been given supervision or instruction by a responsible person concerning use of the Dyson vacuum cleaner or charger to ensure that they can charge and use the Dyson vacuum cleaner safely.
2. Do not allow to be used as a toy. Close attention is necessary when used by or near children. Children should be supervised to ensure that they do not play with the Dyson vacuum cleaner or charger.
3. Do not install, charge or use the Dyson vacuum cleaner outdoors, in a bathroom or within 3.1m of a pool. Do not use the Dyson vacuum cleaner or charger on wet surfaces and do not expose to moisture, rain or snow. Do not use to pick up water.
4. Do not use or charge with damaged cable. If the Dyson vacuum cleaner or charger is not working as it should, has received a sharp blow, has been dropped, damaged, left outdoors, or dropped into water, do not use and contact the Dyson Customer Care Helpline.
5. Do not unplug the charger by pulling on the cable. To unplug, grasp the charger, not the cable.
6. Unplug the charger from the outlet when not in use for extended periods. Make sure the charger cable is located so that it will not be stepped on, tripped over, or otherwise subjected to damage or stress.
7. Do not stretch the charger cable or place the cable under strain. Keep the cable away from heated surfaces.
8. Do not handle the charger, including the charger terminals or Dyson vacuum cleaner with wet hands.
9. Do not put any object into openings. Do not use with any opening blocked; keep free of dust, lint, hair, and anything that may reduce airflow.
10. Keep hair, loose clothing, fingers, and all parts of body away from openings and moving parts.
11. Use extra care when cleaning on stairs.
12. Do not use to pick up flammable or combustible liquids, such as petrol, or use in areas where they may be present.
13. Do not pick up anything that is burning or smoking, such as cigarettes, matches, or hot ashes.
14. Do not use without the clear bin and filter in place.
15. Use only as described in this manual. Use only Dyson recommended accessories and replacement parts. Do not carry out any maintenance other than that shown in this manual, or advised by the Dyson Customer Care Helpline.
16. Contact the Dyson Customer Care Helpline when service or repair is required. Do not disassemble the Dyson vacuum cleaner as incorrect reassembly may result in an electric shock or fire.
17. Use only Dyson chargers for charging this Dyson vacuum cleaner. Use only Dyson batteries, other types of batteries may burst causing injury to persons and damage.
18. Unplug the charger from outlet before cleaning or maintenance.
19. The use of an extension cable is not recommended.
20. Do not incinerate this Dyson vacuum cleaner even if it is severely damaged. The batteries may explode in a fire.
21. Do not press the battery release button during normal operation.

READ AND SAVE THESE INSTRUCTIONS

THIS DYSON VACUUM CLEANER IS INTENDED FOR DOMESTIC HOUSEHOLD AND CAR USE ONLY.



Do not use near naked flame.



Do not store near heat source.



Do not pick up water or liquids.



Do not pick up burning objects.



Do not pull on the cable.

Looking for blockages

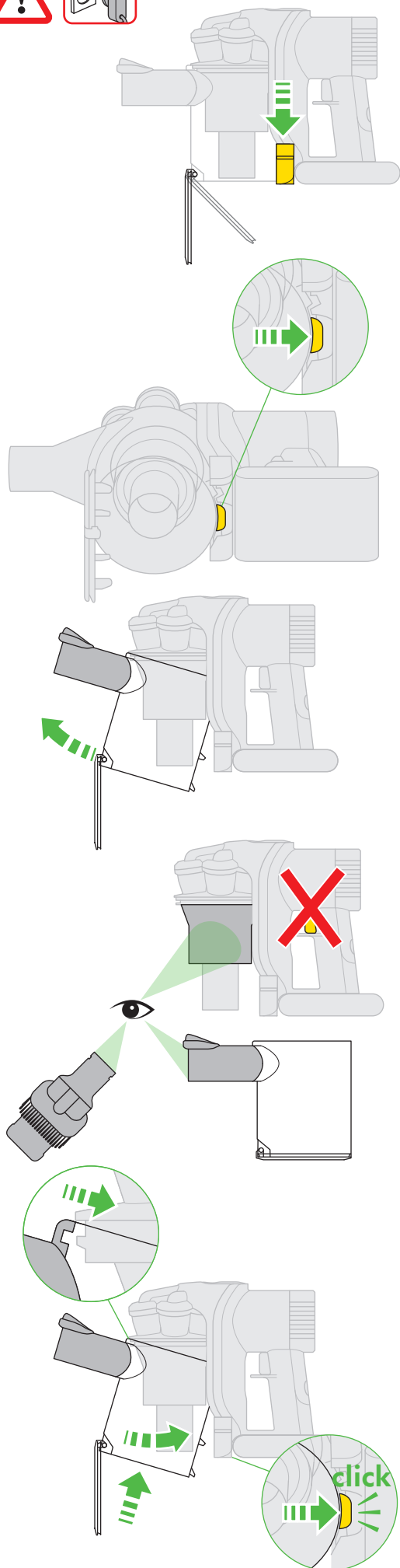

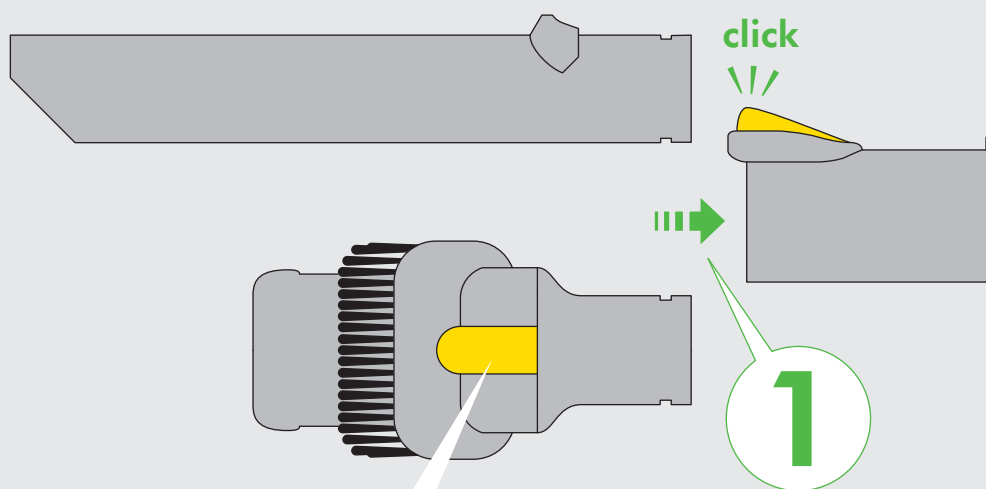
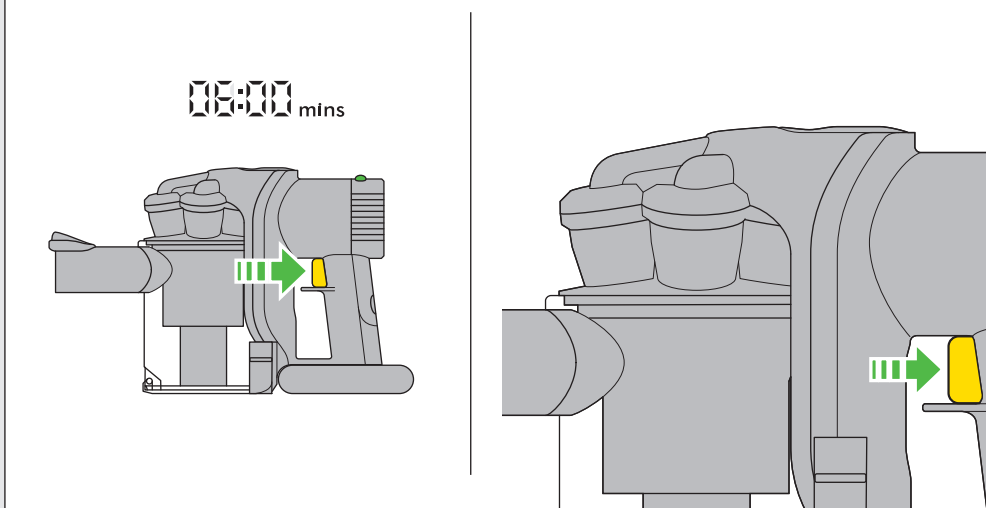

Power



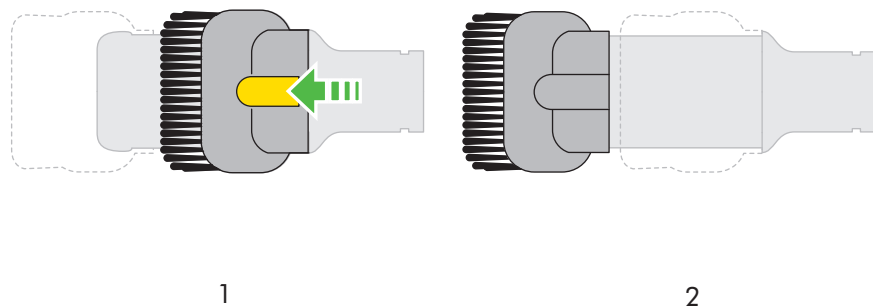

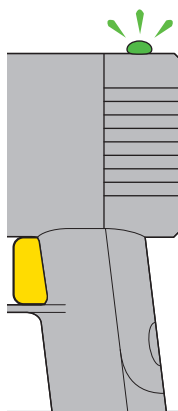
Combination accessory tool





 00:00 min

 Too cold/too hot
 - do not use



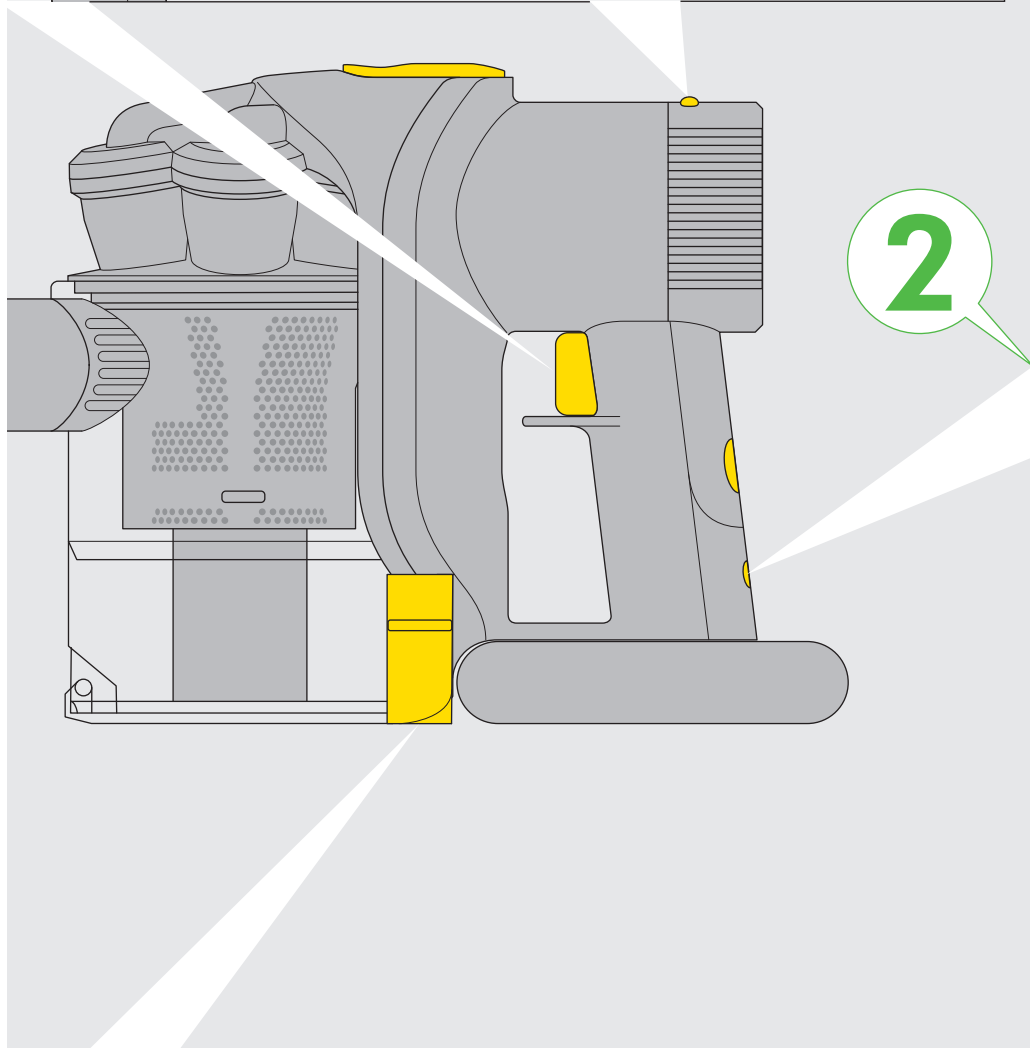

 See page 8

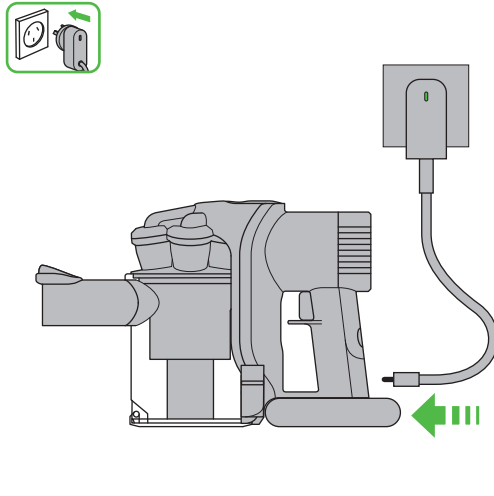
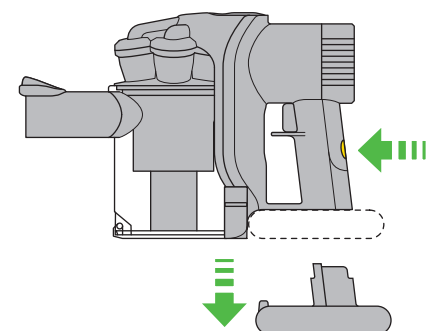
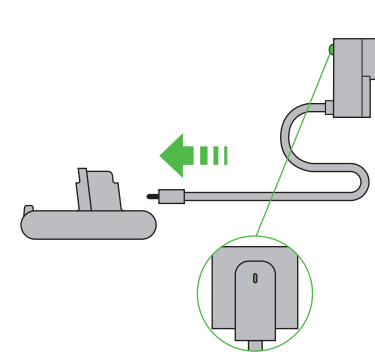

2

Charging

 Charging
 Fully charged
 Not charging, battery fault
 Not charging - too cold/too hot

11 12 1 2 3
 10 3.5 hrs 4
 9
 8
 7 6 5

Emptying the clear bin

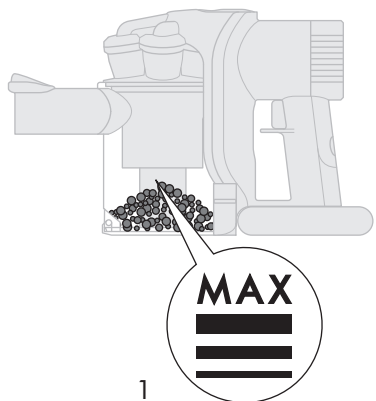

1

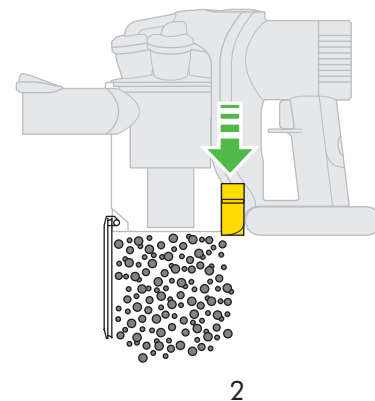

2

IMPORTANT! WASH FILTER



Wash your filter with cold water regularly or as required.

IMPORTANT!

WASH FILTER

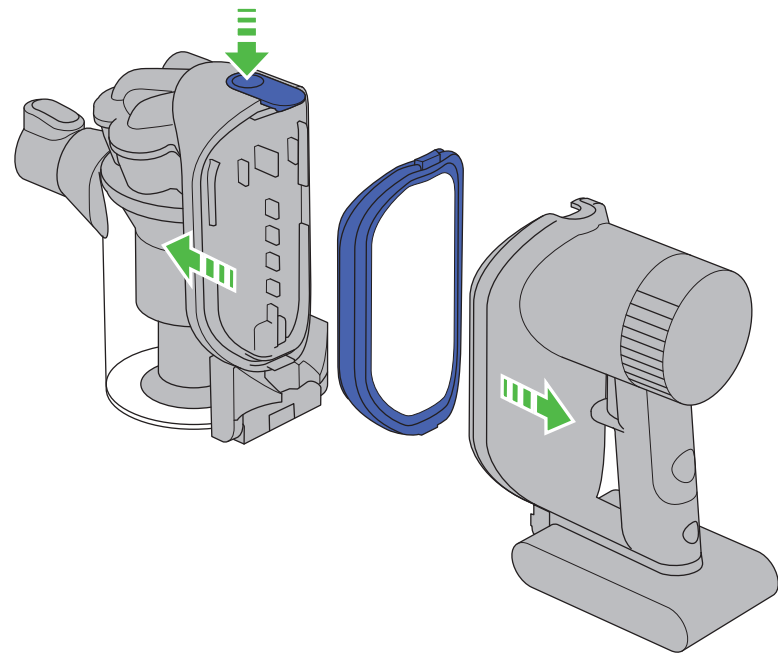
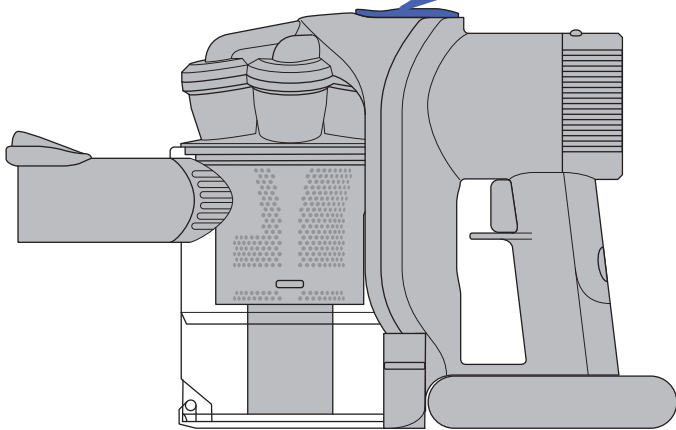
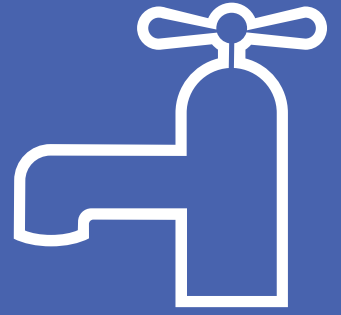

Wash your filter with cold water regularly or as required.

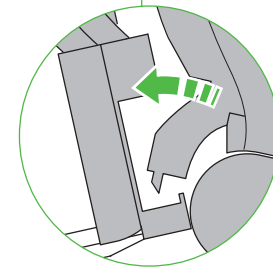
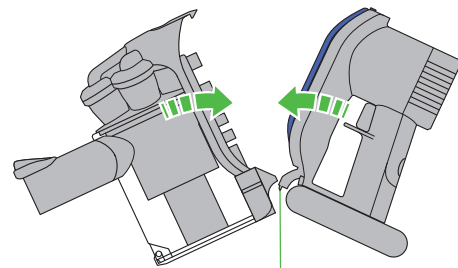
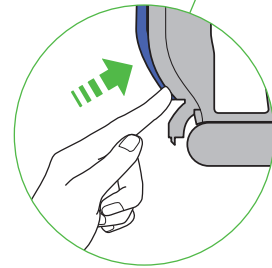
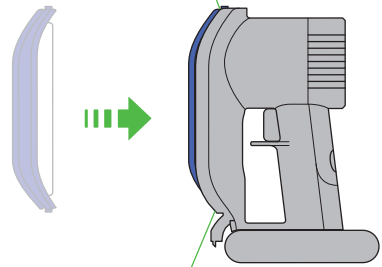
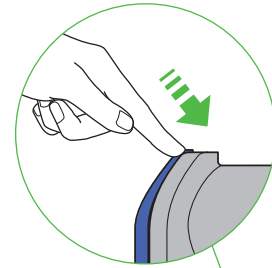
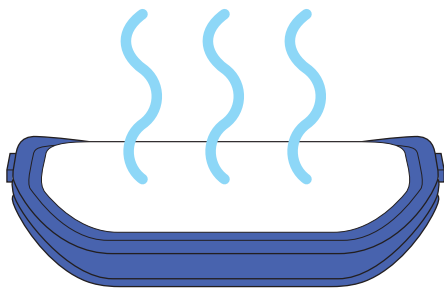
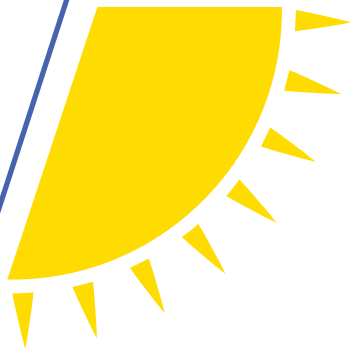

USING THE DYSON VACUUM CLEANER

CAUTION:

- Do not allow the Dyson vacuum cleaner to be used by anyone who may not be able to operate it safely.
- Take care not to engage the silver battery release button during normal operation.
- Dirt and debris may be released from the Dyson vacuum cleaner if it is turned upside down. Ensure the Dyson vacuum cleaner remains upright in use.
- Do not operate the Dyson vacuum cleaner while checking for blockages.
- Do not use outdoors or on wet surfaces or to vacuum water or other liquids – electric shock could occur.
- Do not lubricate any parts, or carry out any maintenance or repair work other than that shown in this Dyson Operating Manual, or advised by the Dyson Customer Care Helpline.

PLEASE NOTE:

- This Dyson vacuum cleaner is designed for domestic indoor and car use only. Do not use it whilst the car is in motion or while driving.
- Do not use the Dyson vacuum cleaner to pick up sharp hard objects, small toys, pins, paper clips, etc. They may damage the Dyson vacuum cleaner.
- Do not press down on the nozzle with excessive force when using the Dyson vacuum cleaner as this may cause damage.
- If the motor overheats, the Dyson vacuum cleaner will cut out automatically. Leave it to cool for at least an hour and check for blockages before restarting.
- Fine dirt such as flour or plaster dust should only be vacuumed in very small amounts.
- Before vacuuming highly polished floors, first check that the underside of the floor tool is free from foreign objects that could cause marking.
- Do not use any lubricants, cleaning agents, polishes or air fresheners on any part of the Dyson vacuum cleaner or charger.
- This Dyson vacuum cleaner is fitted with a thermal cut-out. If any part of the Dyson vacuum cleaner becomes blocked the machine may overheat and automatically shut 'OFF'. If this happens, switch 'OFF' the Dyson vacuum cleaner and allow to cool before attempting to check the filter or for blockages. Clear any blockages before restarting (see pages 4 and 8).
- Store the Dyson vacuum cleaner indoors. Do not use or store this Dyson vacuum cleaner below 3°C. Ensure that the Dyson vacuum cleaner is at room temperature before operating.

TROUBLESHOOTING – DYSON VACUUM CLEANER

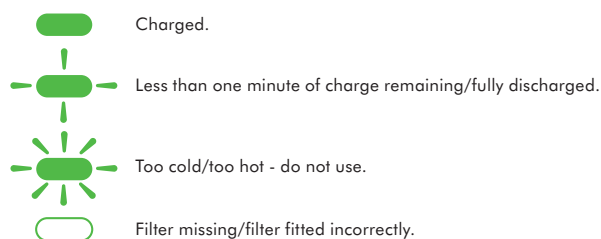

EMPTYING THE CLEAR BIN

CAUTION:

- Switch 'OFF' the Dyson vacuum cleaner and disconnect from charger before emptying the clear bin.
- Empty as soon as the dirt reaches the level of the MAX mark – do not overfill.
- To release the dirt, push the red button at the side of the clear bin as shown on page 5.
- To minimise dust/allergen contact when emptying, encase the clear bin tightly in a plastic bag and empty. Remove the clear bin carefully and seal bag tightly, dispose as normal.

PLEASE NOTE:

- Do not use the Dyson vacuum cleaner without the clear bin in place.

CLEANING THE CLEAR BIN

CAUTION:

- To remove the clear bin, push the red button at the side of the clear bin as you would when emptying the clear bin. Then press the red release button on the underside of the Dyson vacuum cleaner as shown on page 4.
- Clean the clear bin with cold water only.
- Ensure the clear bin is completely dry before replacing.

PLEASE NOTE:

- Do not use detergents, polishes or air fresheners to clean the clear bin.
- Do not put the clear bin in a dishwasher.
- Clean the shroud with a cloth or dry brush to remove lint and dirt.

WASHING THE FILTER

CAUTION:

- Switch 'OFF' and disconnect from charger before removing the filter.
- Wash the filter with cold water only.

PLEASE NOTE:

- This Dyson vacuum cleaner has one filter, located as shown. It is important to check your filter and wash with cold water regularly or as required to maintain performance. The filter may require more frequent washing if vacuuming fine dust or if used mainly in High Constant Suction power mode.

LOOKING FOR BLOCKAGES

CAUTION:

- Switch 'OFF' the Dyson vacuum cleaner before looking for blockages.
 - Beware of sharp objects when clearing blockages.
 - Refit all parts of the Dyson vacuum cleaner securely before using.
- PLEASE NOTE:
- Clearing blockages is not covered by the Dyson vacuum cleaner's guarantee. If any part of the Dyson vacuum cleaner becomes blocked, it may overheat and then automatically shut 'OFF'.
 - Leave the Dyson vacuum cleaner to cool down. Clear blockage before restarting.

CHARGING AND STORING THE DYSON VACUUM CLEANER

- Your Dyson vacuum cleaner will turn 'OFF' if the battery temperature is below 3°C. This is designed to protect the motor and battery of your product. Do not charge the Dyson vacuum cleaner and then move it to an area with a temperature below 3°C for storage purposes.
- To help prolong battery life, avoid recharging immediately after a full discharge. Allow to cool for a few minutes.
- Avoid using the Dyson vacuum cleaner with the battery flush to a surface. This will help it run cooler and prolong battery run time and life.

TROUBLESHOOTING – CHARGER

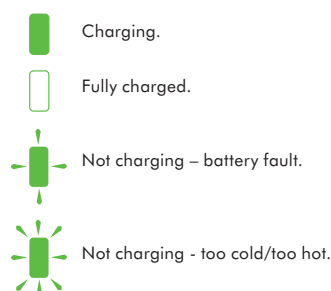

BATTERY SAFETY INSTRUCTIONS

- The Dyson vacuum cleaner must be disconnected from the mains supply when removing the battery.
- Use only Dyson batteries and charging unit for this Dyson vacuum cleaner.
- The battery is a sealed unit and under normal circumstances poses no safety concerns. In the unlikely event that liquid leaks from the battery do not touch the liquid and observe the following precautions:
 - Skin contact – can cause irritation. Wash with soap and water.
 - Inhalation – can cause respiratory irritation. Expose to fresh air and seek medical advice.
 - Eye contact – can cause irritation. Immediately flush eyes thoroughly with water for at least 15 minutes. Seek medical attention.
- Disposal – wear gloves to handle the battery and dispose of immediately following local ordinances or regulations.

CAUTION:

- The battery used in this device may present a risk of fire or chemical burn if mistreated. Do not disassemble, short contacts, heat above 60°C, or incinerate. Replace battery with a Dyson battery only, use of any other battery may present a risk of fire or explosion. Dispose of used battery promptly. Keep away from children. Do not disassemble and do not dispose of in fire.
- The battery must be removed from the Dyson vacuum cleaner before it is disposed of.
 - The battery is to be disposed of safely.
 - The Dyson vacuum cleaner must be disconnected from the supply mains when removing the battery.
 - Battery can be charged on or off the Dyson vacuum cleaner. Take care when removing the battery.

AUSTRALIAN CONSUMER LAW

The details of the Dyson guarantee are set out below. In addition to your rights under the Dyson guarantee, we also provide the following statement as required by the Australian Consumer Law: In Australia, your Dyson vacuum cleaner comes with statutory guarantees that cannot be excluded under the Australian Consumer Law. You are entitled to a replacement or refund for a major failure and for compensation for any other reasonably foreseeable loss or damage. You are also entitled to have your Dyson vacuum cleaner repaired or replaced if it fails to be of acceptable quality and the failure does not amount to a major failure.

DYSON 2 YEAR GUARANTEE TERMS AND CONDITIONS

Terms and conditions of your Dyson 2 year guarantee.

- The Dyson guarantee becomes effective from the date of purchase.
- All work will be carried out by Dyson Appliances (Aust) Pty Ltd., Avery Robinson Ltd. (NZ), Singapore's authorised agent - Service @Home Pte Ltd., Indonesia's authorised agent - PT Higienis Indonesia or their authorised agents.
- Any parts replaced will become the property of Dyson Appliances (Aust) Pty Ltd., Avery Robinson Ltd. (NZ), Dyson Singapore Pte Ltd. or PT Higienis Indonesia.
- The repair and replacement of your Dyson vacuum cleaner under Dyson guarantee will not extend the Dyson guarantee period.
- The Dyson guarantee provides benefits which are additional to and do not affect your statutory rights and remedies as a consumer.
- You must provide proof of (both original and any subsequent) delivery/purchase before any work can be carried out on your Dyson vacuum cleaner. Without this proof, any work carried out pursuant to the Dyson guarantee and any associated delivery charges (both to and from us) will be at your cost, subject to your statutory rights and remedies as a consumer. Please keep your receipt or delivery note.

WHAT IS COVERED

Your Dyson guarantee covers:

- The repair or replacement of your Dyson vacuum cleaner if your Dyson vacuum cleaner is found to be defective due to faulty materials, workmanship or function within 2 years of purchase or delivery (if any part is no longer available or out of manufacture Dyson will replace it with a functional replacement part).
- Use of the Dyson vacuum cleaner in the country of purchase.

WHAT IS NOT COVERED

Under your Dyson guarantee, Dyson shall not be liable for costs of repair or replacement of a product incurred as a result of:

- Normal wear and tear (e.g. fuse, belt, brush bar, batteries etc).
- Reduction in battery discharge time due to battery age or use.
- Industrial use of the Dyson vacuum cleaner such as vacuuming gyprock dust or builders dust. This may void your Dyson guarantee.
- Accidental damage, faults caused by negligent use or care, neglect, careless operation or handling of the Dyson vacuum cleaner which is not in accordance with this Dyson Operating Manual.
- Blockages – please refer to this Dyson Operating Manual for details of how to unblock your Dyson vacuum cleaner.
- Use of the Dyson vacuum cleaner for anything other than normal domestic household purposes in the country of purchase.
- Use of parts not assembled or installed in accordance with the instructions of Dyson.
- Use of parts and accessories other than those produced or recommended by Dyson.
- Damage from external sources such as transit, weather, electrical outages or power surges.
- Failures caused by circumstances outside Dyson's control.
- Repairs or alterations carried out by parties other than Dyson or its authorised agents.

If your Dyson guarantee does not apply, you may have statutory rights and remedies available to you as a consumer.

If you are in any doubt as to what is covered by your Dyson guarantee, please call the Dyson Customer Care Helpline on:

Australia 1800 239 766
New Zealand 0800 397 667
Singapore 7000 435 7546
Indonesia 021 707 39766

Remember: Always disconnect plug from mains before inspecting for problems.

- Sucking up certain items such as stockings, clippings of cloth, sizeable pieces of paper etc may block the hose or ducts. Should a blockage occur, refer to the 'Looking for blockages' section in this Dyson Operating Manual (see pages 4, 6 and 8).
- Never pick up hot cinders or lit cigarette ends.
- Do not attempt to pick up water with your Dyson vacuum cleaner. It has not been designed as a wet pick up cleaner.

REGISTERING YOUR DYSON GUARANTEE

To help us ensure you receive prompt and efficient service, please register as a Dyson vacuum cleaner owner. There are three ways to do this:

- Online (Australia and New Zealand only)
AU: www.dyson.com.au/register
NZ: www.dyson.co.nz/register
 - By calling the Dyson Customer Care Helpline.
 - By completing and returning the enclosed form to us by mail.
- This will confirm ownership of your Dyson vacuum cleaner in the event of an insurance loss, and enable us to contact you if necessary.

DYSON CUSTOMER CARE

THANK YOU FOR CHOOSING TO BUY A DYSON VACUUM CLEANER

- If you have a query about your Dyson vacuum cleaner, call the Dyson Customer Care Helpline and quote your serial number, or contact us via the website. Your serial number can be found on the main body of the Dyson vacuum cleaner behind the filter.
- Most queries can be solved over the phone by one of our Dyson Customer Care Helpline staff.
- If your Dyson vacuum cleaner needs a service, call the Dyson Customer Care Helpline so we can discuss the available options.
- To enable us to carry out work on your Dyson vacuum cleaner please contact the Dyson Customer Care Helpline to obtain a reply paid delivery address in your state (available in Australia only).
- If your vacuum cleaner is under Dyson guarantee and the repair or replacement is covered, it will be repaired or replaced at no cost. If the repair or replacement is found not to be covered under the Dyson guarantee, the repair or replacement of the vacuum cleaner and any associated delivery charges (both to and from us) will be at your cost, subject to your statutory rights and remedies as a consumer.

DYSON CUSTOMER CARE DETAILS

If there are any queries, please call the Dyson Customer Care Helpline.

AU: 1800 239 766

(Mon-Fri 8:00am to 6:00pm EST, Sat-Sun 8:30am to 4:00pm EST)

www.dyson.com.au

NZ: 0800 397 667 (Mon-Fri 8:30am to 5:00pm)

www.dyson.co.nz

SG: 7000 435 7546 (Mon-Fri 9:00am to 6:00pm)

www.dyson.com.sg

ID: 021 707 39766 (Mon-Fri 9:00am to 5:00pm)

www.dyson.co.id

ABOUT YOUR PRIVACY

Dyson may use your information provided for future marketing and research purposes (including sending commercial electronic messages) and may disclose it to third parties for the purposes of providing the services you have requested, or to our business partners or professional advisers. If you wish to access your personal information or see our full privacy policy, please contact us at customercare@dyson.com.au

DISPOSAL INFORMATION

- Dyson products are made from high grade recyclable materials. Please dispose of this product responsibly and recycle where possible.
- The battery should be removed from the product before it is disposed of.
- Dispose of, or recycle the battery in accordance with local ordinances or regulations.

When your Dyson vacuum cleaner reaches the end of its life, we are responsible for its safe disposal. You can send your old Dyson vacuum cleaner back to us (at our cost) and we will organise for it to be recycled.*

*Please note that not all parts are recyclable. Recycling of parts is subject to the capabilities of 3rd party suppliers. Available in Australia only.

Simply:

1. Box up your old Dyson vacuum cleaner
2. Take the package to your local post office and send to the address below:

Dyson We Recycle

Reply Paid 83215

Dyson Service Centre

Unit 6 & 7, 7-11 Parraweena Rd

Taren Point, NSW 2229

PRODUCT INFORMATION

Please note: Small details may vary from those shown.

IMPORTANT!

WASH FILTER



Wash your filter with cold water regularly or as required.

Register for a filter wash reminder by email (Australia only):
customercare@dyson.com.au



Dyson Customer Care

If you have a query about your Dyson vacuum cleaner, call the Dyson Customer Care Helpline with your serial number and details of where and when you bought the Dyson vacuum cleaner, or contact us via the Dyson website. The serial number can be found on the main body of the Dyson vacuum cleaner, behind the filter.

AU Dyson Customer Care
customercare@dyson.com.au
1800 239 766
Dyson Appliances (Aust) Pty Ltd.,
PO Box 2835,
Taren Point, NSW 2229,
Australia
www.dyson.com.au

NZ Dyson Customer Care
dyson@averyrobinson.co.nz
0800 397 667
Avery Robinson Ltd.,
Unit F, 151D Marua Road,
Ellerslie, Auckland 1051,
New Zealand
www.dyson.co.nz

SG Dyson Customer Care
Singapore@dyson.com
7000 435 7546
Service @ Home Pte Limited,
2 Leng Kee Road,
#04-09A Thye Hong Centre,
Singapore 159086
www.dyson.com.sg

ID Dyson Customer Care
Service@higienis.com
021 707 39766
PT. Higienis Indonesia
Permata Plaza Top Floor TF-04,
JI, M. H. Thamrin Kav. 57,
Jakarta 10350,
Indonesia
www.dyson.co.id

Please take a few moments to answer our questions. They will help us develop new products for the future.

1 This handheld is...

- My first handheld (please go to question 3)
- A replacement handheld
- An additional handheld

2 Which brand of handheld are you replacing or adding to?

- Dyson
- Piranha
- Electrolux
- Breville
- Black and Decker
- Other, please specify

3 Why did you choose to buy a Dyson handheld? (Please rank in order, 1-5, 1 being the most important).

	1	2	3	4	5
Dyson reputation	<input type="checkbox"/>	<input type="checkbox"/>	<input type="checkbox"/>	<input type="checkbox"/>	<input type="checkbox"/>
No loss of suction	<input type="checkbox"/>	<input type="checkbox"/>	<input type="checkbox"/>	<input type="checkbox"/>	<input type="checkbox"/>
Features	<input type="checkbox"/>	<input type="checkbox"/>	<input type="checkbox"/>	<input type="checkbox"/>	<input type="checkbox"/>
Price/special offer	<input type="checkbox"/>	<input type="checkbox"/>	<input type="checkbox"/>	<input type="checkbox"/>	<input type="checkbox"/>
Store staff recommendation	<input type="checkbox"/>	<input type="checkbox"/>	<input type="checkbox"/>	<input type="checkbox"/>	<input type="checkbox"/>
Picks up more dust than others	<input type="checkbox"/>	<input type="checkbox"/>	<input type="checkbox"/>	<input type="checkbox"/>	<input type="checkbox"/>
Friend/family recommendation	<input type="checkbox"/>	<input type="checkbox"/>	<input type="checkbox"/>	<input type="checkbox"/>	<input type="checkbox"/>
Other, please specify <input type="text"/>					

4 Where did you first hear about Dyson handhelds?

- From friends and family
- TV or a magazine advert
- Saw it in a store catalogue
- Saw it in a store
- Recommended by salesperson

5 Where did you look for additional information?

- Dyson website
- Online reviews and forums
- Retail staff
- Retail catalogue
- Email from Dyson
- No additional research was done

6 Do you own other Dyson products?

- Vacuum cleaner
- Handheld
- Handstick
- Fan
- No

7 What is your average household income?

- Less than \$45,000
- Between \$45,000 - \$74,000
- Between \$75,000 - \$100,000
- Over \$100,000

8 Do you have any household pets?

- Dog
- Cat
- No
- Other, please specify

9 Does anyone in your household suffer from any of the following?

- Asthma
- Allergies
- No

10 To which age group do you belong?

- 16 - 24
- 25 - 34
- 35 - 44
- 45 - 54
- 55 - 64
- 65+

11 Would you recommend a Dyson handheld to your family?

- Yes
- No

12 Do you have children?

- Pre-school
- Aged 5 - 17 years
- Aged 17+ years
- Children no longer at home
- Pregnant
- No children

13 Which best describes your house?

- (Tick one from each column).
- Own house
 - Rented house
 - Own apartment/villa
 - Rented apartment/villa
 - Live with parents
 - Share accommodation
 - Up to 2 beds
 - 3-4 beds
 - More than 4 beds

THANK YOU FOR YOUR TIME





GUARANTEE FORM

Date of purchase / /

Country of purchase Australia New Zealand
 Singapore Indonesia

Serial number

Title Surname

First name

Address

Postcode

e-mail

Telephone Mobile

Store of purchase

Warranty
Did you purchase an extended warranty? Yes No
If yes, for what additional period? 1 year 2 years 3 years

Privacy Act
Dyson may use this information for future marketing and research purposes (including sending commercial electronic messages) and may disclose it to third parties for the purposes of providing the services you have requested or to our business partners or professional advisers. If you wish to access your personal information or see our full privacy policy, please contact us at customer@dyson.com.au
If you do not wish to receive marketing information by these methods from Dyson please tick this box.

3 EASY WAYS TO REGISTER YOUR DYSON 2 YEAR GUARANTEE

REGISTER ONLINE



Visit our website to register your Dyson full parts and labour guarantee online (Australia and New Zealand only).

AU: www.dyson.com.au/register
NZ: www.dyson.co.nz/register

REGISTER BY PHONE



Call our dedicated Helpline.

AU 1800 239 766
NZ 0800 397 667
SG 7000 435 7546
ID 021 707 39766

REGISTER BY MAIL



Complete and return the form to Dyson in the envelope supplied.



Free Manuals Download Website

<http://myh66.com>

<http://usermanuals.us>

<http://www.somanuals.com>

<http://www.4manuals.cc>

<http://www.manual-lib.com>

<http://www.404manual.com>

<http://www.luxmanual.com>

<http://aubethermostatmanual.com>

Golf course search by state

<http://golfingnear.com>

Email search by domain

<http://emailbydomain.com>

Auto manuals search

<http://auto.somanuals.com>

TV manuals search

<http://tv.somanuals.com>