

EVID Ceiling Speaker Systems

EVID C4.2 | EVID C8.2 | EVID C8.2LP | EVID C8.2HC | EVID C10.1

en | Installation Manual



Table of contents

1	Safety	4
2	Welcome	5
2.1	Important Features	5
3	System overview	6
3.1	Model Summary	6
3.2	Packing List	7
3.3	Product Feature Identification	8
4	Installation and Wiring	10
4.1	Step 1 – Cut the Hole	11
4.2	Step 2 – Install C-Ring and/or Tile Rails	11
4.3	Step 3 – Attach Wiring to the Terminal Connector	12
4.4	Step 4 – Secure the Cable to the Speaker	14
4.5	Step 5 – Mount the Speaker into the Ceiling	15
4.6	Step 6 – Connect an Auxiliary Support Line	15
4.7	Step 7 – Adjust Tap Selector	16
4.8	Step 8 – Attach the Grille	16
5	Troubleshooting	18
6	Technical data	19
7	Appendices	21
7.1	Appendix A – Painting the Speaker	21
7.2	Appendix B – System Design Guide	21
7.2.1	Selecting and Positioning Ceiling Loudspeakers	21
7.2.2	Ceiling Systems: Size vs. Coverage	22
7.2.3	Use of Subwoofers	23

1

Safety



Caution!

The seismic tab (auxiliary support ring) is not intended for primary suspension of the loudspeaker. The seismic tab should only be used as a secondary safety point.



Caution!

Ceiling mount speaker's safety cable
The safety cable should be installed with a minimum of 3-inches (76.2 mm) of slack.



Notice!

ATTENTION: UL SAFETY LISTING

All EVID ceiling speaker models are listed under UL standard UL1480 as a signaling speaker.
All models are also suitable for use in air handling spaces per UL2043.

2 Welcome

Thank you for purchasing EVID Ceiling Series loudspeakers. Read through this manual to familiarize yourself with features, applications, and precautions before you use these products.

EVID Ceiling Series loudspeakers use innovative design and materials to provide premium-level performance in a flush-mount ceiling format. Four models comprise the EVID Ceiling Series: the C4.2 with a 4-inch LF driver and a 0.75-inch, titanium coated tweeter with waveguide; the C8.2 with an 8-inch LF driver and a 1-inch titanium-coated tweeter with waveguide; the C8.2HC with a fully waveguide loaded 8-inch LF driver and a 1-inch titanium coated tweeter; and the EVID C10.1 , a true ceiling-mounted subwoofer designed to augment and extend the full-range model's low-frequency response.

2.1 Important Features

- Matches acoustically to the EVID surface-mount speaker line
- Model for model, has superior performance to competing brands
- Comes with both 70V/100V or 8-ohm operation standard on every model
- Includes all installation accessories commonly needed for most jobs

3 System overview

3.1 Model Summary

EVID C4.2

Perfect for conventional rooms. It has excellent bandwidth in an esthetically very unobtrusive installation profile. Its compact design fits in tight areas. Its 4-inch woofer and waveguide-coupled, titanium-coated dome tweeter give smooth, wide frequency response. The enclosure is ported and tuned to provide surprising bass response in such a compact package. Features an easy 3-point mounting system for quick installations.

EVID C8.2

The C8.2 has a specially tuned enclosure and 8-inch woofer to provide amazing bass response. The 1-inch waveguide-coupled tweeter gives smooth controlled coverage out to 20 kHz. Perfect for installations where a flush-mount design is desired but demand for high-quality audio exists. Features a 4-point mounting system to make installations fast and easy.

EVID C8.2LP

The C8.2LP is the same as the C8.2 but in a low-profile installation package. Ideal for tight ceiling spaces.

EVID C8.2HC

The EVID C8.2HC is ideal for high ceilings and reverberant “problem” rooms. Its exclusive ported, waveguide-coupled, 8-inch driver provides excellent intelligibility and definition. The C8.2HC’s patent pending design provides great coverage control throughout the voice range and above. No other ceiling speaker system provides the combination of excellent pattern control, wide bandwidth, high power handling, and compact design like the C8.2HC.

EVID C10.1

The C10.1 packs a 10-inch subwoofer in a tuned high performance enclosure to give amazing low frequency performance down to 45 Hz! It is one of the few quick-mount ceiling TRUE subwoofers available. Flexible installation and powerful low-end performance make it the ideal mate to any EVID ceiling model.

3.2 Packing List

Item	Quantity	Part
A	2	Speaker system
B	4	Tile rails
C	2	C-ring support
D	2	Grille
E	1	Owner's manual
F	4	Support ring screws
G	2	Terminal connector
H	1	Service center card
I	1	Cutout template
J	2	Paint shield

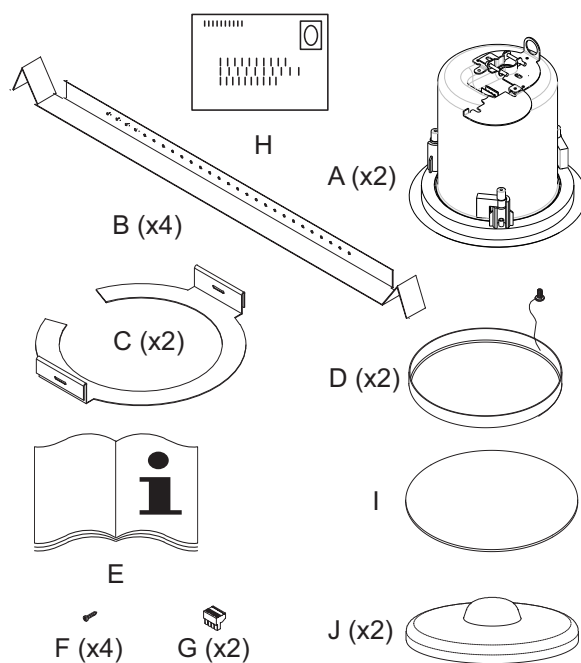

Figure 1: EVID packing list

3.3 Product Feature Identification

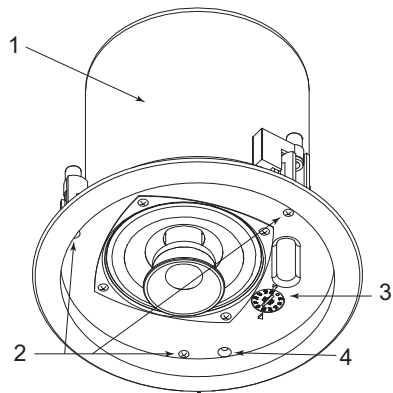

Figure 2: Bottom of speaker

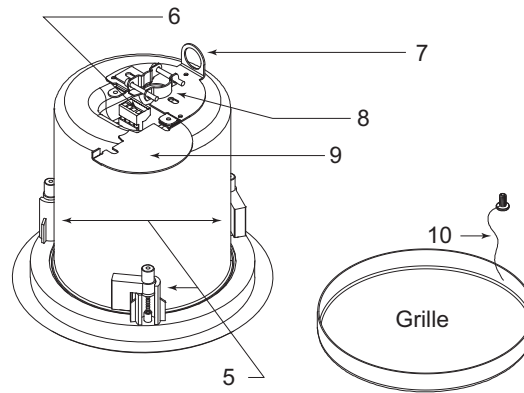

Figure 3: Top of speaker

Item	Description	Item	Description
1	Steel back can	6	Removable input terminal connector
2	Mounting screws	7	Seismic tab (auxiliary support ring)
3	Tap selector	8	Strain relief fitting
4	Grille safety tether hole	9	Terminal cover plate
5	Rotating mounting tabs	10	Grille safety tether

EVID Ceiling Series Systems (sold in pairs)

Model Part No	Description
EVID C4.2	4" coaxial speaker with horn-loaded, Ti-coated tweeter
EVID C8.2	8" coaxial speaker with horn-loaded, Ti-coated tweeter
EVID C8.2LP	Same as C8.2 above except with low-profile backcan
EVID C8.2HC	8" waveguide-coupled coaxial speaker with horn-loaded, Ti-coated tweeter
EVID C10.1	10" High performance subwoofer

EVID Series Ceiling Mount Speaker Accessories

Model Part No.	Description
RR-42-B	Rough-in plate for new construction involving the EVID C4.2 (package of 4)
RR-82	Rough-in plate for new construction involving the EVID C8.2 and C8.2LP (package of 4)
RR-810	Rough-in plate for new construction involving the EVID C8.2HC and C10.1 (package of 4)
RPK-42	Rough-in package for new construction involving the C4.2 speaker only (package of 2)

Model Part No.	Description
RPK-82	Rough-in package for new construction involving the C8.2 and C8.2LP speaker only (package of 2)
RPK-810-B	Rough-in package for new construction involving the C8.2HC and C10.1 speaker only (package of 2)

NOTE: All products are not available in all regions.

4 Installation and Wiring

The EVID mounting system has been designed so that, if necessary, the installation can be done from beneath the ceiling. In some cases with a suspended ceiling grid, however, it may be easier to access from both the top and bottom of the ceiling tile during the installation process. Typical installation hardware needed for either suspended ceilings or sheetrock ceilings is included. The ceiling speaker assembly is held in place by mounting tabs that securely grip the ceiling material. Input wiring is attached to a removable terminal block connector that can be prewired if necessary before speaker installation to speed up the installation process.

INSTALLATION NOTE: USE OF OPTIONAL ROUGH-IN ACCESSORIES

For most installations, no additional hardware is needed. However, a two-step installation procedure that is sometimes used for installation into sheetrock ceilings can be made easier by the use of the optional RR and RPK series of rough-in accessories before the ceiling material is installed. The rough-in accessories provide a cutout guide when many holes are to be made in a production-line style installation and to ensure the speakers are positioned correctly as the holes are cut in the sheetrock. Depending on the requirements, two types of rough-in accessories are available.

RR Series Mounting Plates

RR series plates are made of flat sheet metal with holes to attach to the joists or trusses of a building structure. The holes are drilled for nails or screws at 16 inches (406 mm), 20 inches (508 mm) and 24 inches (610 mm) on-center. The installer can drill other holes as needed up to a maximum of 24-3/4 inches (630 mm) apart. The sheetrock installs over the plate and the plate provides a template for a blind cutout of the hole in the sheet rock. The ceiling material is generally cut with a router-type cutting tool, using the plate ring as a cutout guide.

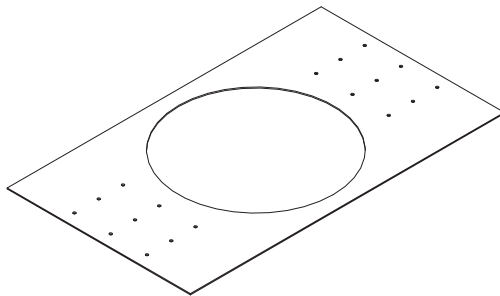

Figure 4: Speaker mounting plate

RPK Series Kits

The RPK series rough-in kit contains a RR series plate with a standard 2 gang electrical box mounted on the top with an attached short length of flexible conduit which connects to the ceiling speaker conduit clamp on the speaker's rear terminal cover. This accessory allows for rigid conduit to be run to the box on the rough-in plate before the speaker or any sheetrock is installed. After the sheetrock is installed the speaker can be wired up and mounted all from below the ceiling.

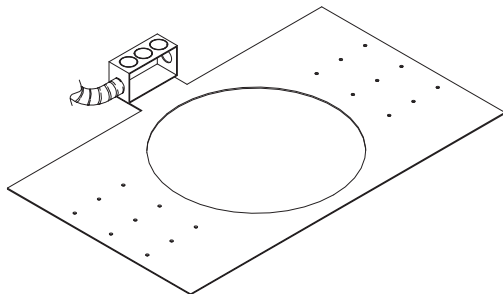

Figure 5: RPK mounting system

INSTALLATION NOTE: CONTROLLING VIBRATION

Because of their high performance, EVID ceiling loudspeakers can generate substantial vibration, which can cause buzzing in loose sections of the ceiling structure. Depending on the character of the ceiling tile and related components, dampening material may need to be used under the tile rails or the edges of the tiles to eliminate rattles.

4.1

Step 1 – Cut the Hole

For suspended tile or sheetrock ceilings, cut out the hole either by tracing the cardboard template or with a circular cutter set to the appropriate cutout size. If the wire has been pre-installed, pull the wiring through the cutout hole.

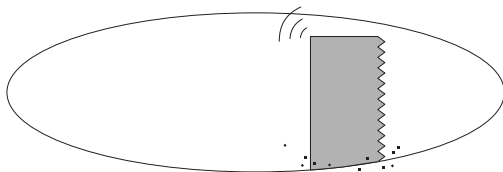

Figure 6: Cut ceiling hole

4.2

Step 2 – Install C-Ring and/or Tile Rails

All EVID speakers come packaged with two types of backing hardware: a C-ring and two tile rails. For suspended ceiling installations, insert the C-ring through the hole cut in the ceiling tile. Place the C-ring around the hole with the tabs located as shown in Figure 7. Insert the tile rails through the cut hole in the ceiling tile. Snap the two rails into the two tabs in the C-ring and align the rails so that the ends extend OVER the T-channel grid on the side of the tile. Secure the rails onto the C-ring tabs by inserting a screw through each tab into the rail, as shown in Figure 7.

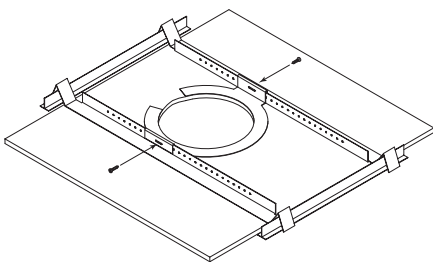

Figure 7: Secure rails to C-Ring

INSTALLATION NOTE: TILE RAILS AND C-RING

Each speaker comes with two tile rails which are designed to fit either standard 24-inch-wide or 600-mm-wide tiles. It is important to note that the tile rail pieces do not actually attach to the T-grid struts. The ends of the rails sit OVER the T-grid strut. Normally, the tile supports the rails. The tile rails are pre-punched at regular intervals with holes along their length. This allows the C-ring to be positioned at any point along the rail. If the tile comes out or falls apart, the ends of the support rails fall onto the T-grid, which prevents the speaker assembly from falling.

Always use all included support hardware when installing into suspended ceiling tiles to make sure the installation is secure.

For sheetrock ceiling installations, the C-ring should be used by itself to reinforce the ceiling material and to spread out the pressure from the speaker hold-down tabs. Guide the C-ring through the cut hole in the ceiling, and place it on the back side of the hole before inserting the speaker.

4.3

Step 3 – Attach Wiring to the Terminal Connector

Insert the bare end of wire into the appropriate connector terminals as described below and screw down the hold-down screw until tight, using a small screwdriver.

INSTALLATION NOTE: CONNECTOR

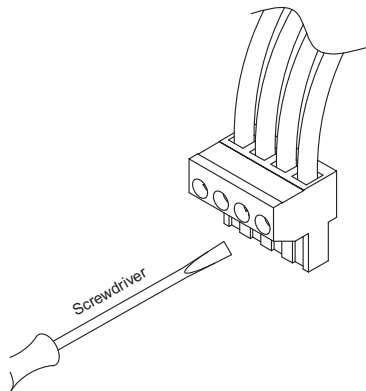

Figure 8: Tighten with screwdriver

WIRING GUIDELINES

The input connector's four (4) terminals are numbered and marked on the connector. Pins 1 and 2 are positive (+); pins 3 and 4 are negative (-).

Note: Pin 1 is connected to Pin 2 and Pin 3 is connected to Pin 4 inside the speaker. Pins 1 and 4 are used as daisy-chain connections to other loudspeakers.

Two possible layouts for wiring a group of speakers are described below.

1. Wiring in parallel. Connect the wire pair of the subsequent speaker to pins 2 and 3. When one input connector is removed, subsequent speakers will remain connected. See Figure 9.
2. Daisy-chaining. Connect the wire pair of the subsequent speaker to pins 1 and 4. When one input connector is removed, subsequent speakers will also be disconnected. See Figure 10.

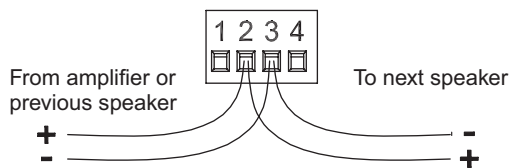

Figure 9: Parallel wiring

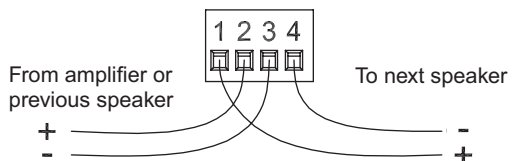

Figure 10: Daisy-chain wiring

INSTALLATION NOTE: SUBWOOFER POLARITY

When adding a subwoofer, be sure to observe the correct polarity. The C10.1 subwoofer has been designed for optimum performance when used with the C4.2. In order to maximize the low frequency output when used with the C8.2, C8.2LP or C8.2HC, the polarity of the C10.1 subwoofer should be reversed. See Figures 11 and 12.

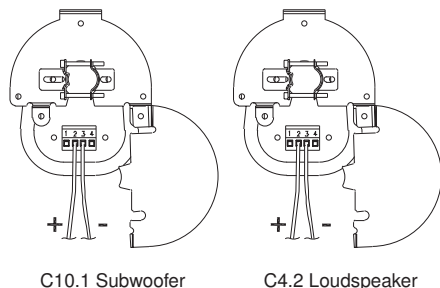

Figure 11: Subwoofer polarity with C4.2

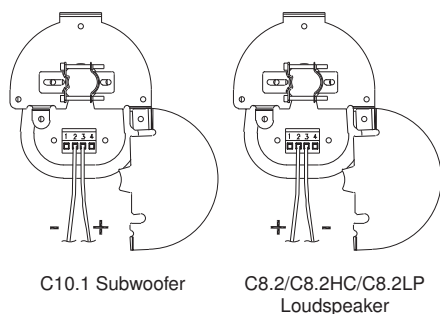

Figure 12: Subwoofer polarity with C8.2/C8.2HC/C8.2LP

When all wiring has been completed to the connector, plug the input connector (A) into the socket in the speaker’s terminal cup (B). See Figure 13. Tighten all screws to eliminate vibration.

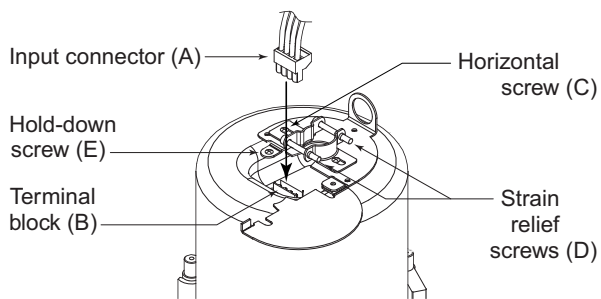

Figure13: Plug connector into socket

4.4

Step 4 – Secure the Cable to the Speaker

Fully loosen the horizontal screw (C) shown in Figure 13, then the strain relief screws (D). Run the wires through the opening in the fitting and plug the input connector (A) into the speaker's terminal block (B). Then tighten the strain relief fitting as follows:

1. If plenum cable is used, slide the wiring through the strain relief fitting on the terminal cover plate (Figure 14). Hold the strain relief fittings tight around the cable. Tighten the strain relief screws first, then the horizontal screw. In the cases of insulated speaker wire and plenum cable, it is often possible to provide acceptable strain relief force by simply tightening the strain relief screws onto the terminal cover plate.
2. If the installation used flexible (BX) or rigid (EMT) conduit, an alternate conduit fitting can be used. See Installation Note and Figure 15.

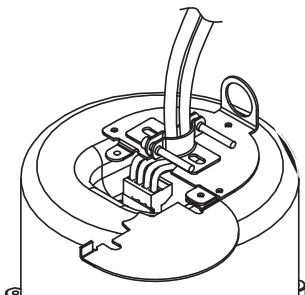

Figure 14: Secure cable through fitting

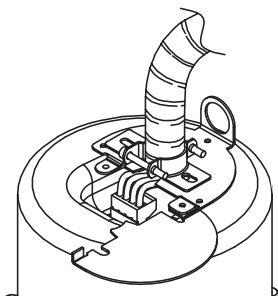

Figure 15: Alternate conduit fitting

INSTALLATION NOTE: ALTERNATE CONDUIT FITTINGS

Some cases require alternate fittings, many of which are available through most electrical suppliers. Simply remove the existing fitting by unscrewing the two hold-down screws, exposing a 7/8-inch (22 mm) knockout hole. Then install the alternate fitting. Make sure to always use a listed fitting in accordance with your area's building codes and regulations.

4.5 Step 5 – Mount the Speaker into the Ceiling

Push the speaker into the ceiling hole until the front baffle rim is flush with the ceiling. Tighten the mounting tabs by turning the screw clockwise until the speaker is secure. Please note that the first clockwise quarter-turn rotates the attachment tabs outward. The remaining turns tighten the tabs down onto the back of the ceiling surface (see Figure 17).

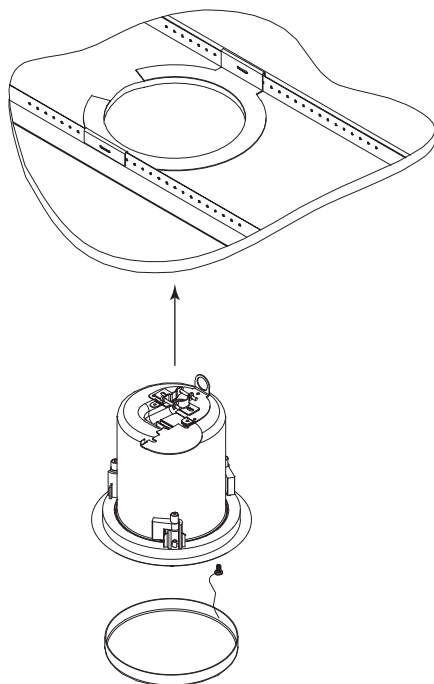

Figure 16: Mount speaker into ceiling

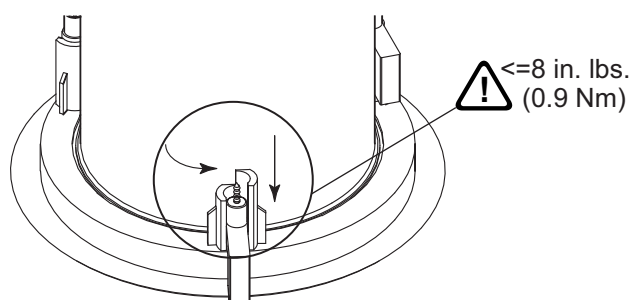

Figure 17: Tighten mounting tabs

INSTALLATION NOTE: MOUNTING TABS

For each attachment screw, first turn one half-turn counterclockwise to release the mounting tab from its guide.

4.6 Step 6 – Connect an Auxiliary Support Line

Note the support ring on the back of the speaker. The ring allows for connection to a independent and secure anchor point. Construction codes often require the use of this secondary support point.



Caution!

Ceiling mount speaker's safety cable

The safety cable should be installed with a minimum of 3-inches (76.2 mm) of slack.

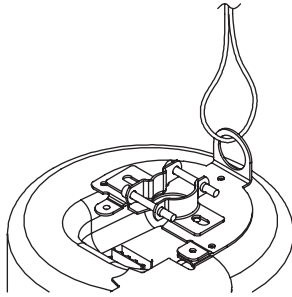

Figure 18: Attach auxillary support line

4.7

Step 7 – Adjust Tap Selector

The tap selector switch is located on the front baffle. Adjust the speaker to the appropriate tap setting before installing the grille. In some 70V/100V constant voltage installations it is advisable to leave the grilles off if final speaker audio level balance adjustments are to be made later. After the levels are adjusted the grilles can then be installed.

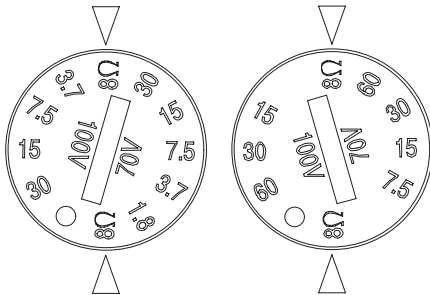

Figure 19: Adjust tap selector (left: C4.2/C8.2/C8.2LP; right: C10.1/C8.2HC)

EVID C4.2, C8.2, and C8.2LP

In addition to the 8-ohm setting, the power taps are 30 W, 15 W, 7.5 W, and 3.7 W at both 70.7V and 100V, with a 1.8 W tap for 70.7V only.

EVID C8.2HC and C10.1

In addition to the 8-ohm setting, the power taps are 60 W, 30 W, and 15 W at both 70.7V and 100V, with a 7.5 W tap for 70.7V only.

4.8

Step 8 – Attach the Grille

INSTALLATION NOTE: GRILLE SAFETY FEATURE

EVID grilles features a unique safety tether to prevent the grille from falling if the grille is removed or comes loose after installation.

First, install the grille's safety tether by pushing the grille fastener into the hole in the front of the baffle (see Figure 20). Second, press the grille into place until the front of the grille is flush with the rim of the baffle. Make sure the grille is securely seated to prevent it from vibrating loose.

If you need to remove the grille, the easiest way is to insert two bent paper clips or other pointed objects into holes in the grille, then apply slow even pressure to pull down on the grille until that section of the grille comes out slightly. Continue the same procedure around the perimeter of the grille, loosening a portion at a time until the grille is removed.

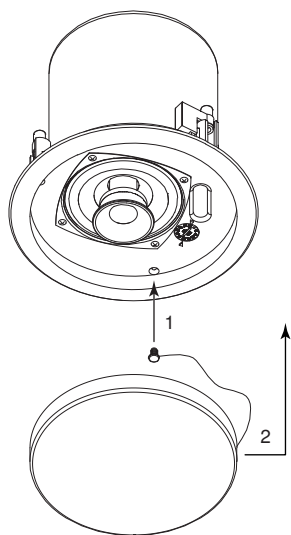

Figure 20: Attach the grille

5 Troubleshooting

Problem	Possible Causes	Action
No output	Amplifier	<p>Ensure the amplifier channel is being fed an input signal (preferably via a signal input indicator on the amplifier).</p> <p>Verify the amplifier channel's volume is turned up.</p> <p>Connect the loudspeaker and cable, which had no output to another amplifier channel, ensuring an input signal is fed to the new amplifier channel. If you then get output, the problem was the amplifier channel. If not, then the problem is either the cable or the loudspeaker.</p>
	Loudspeaker cables(s)	Replace the cable(s) connecting the loudspeaker system and amplifier.
Questionable or intermittent output, such as crackling	Faulty connection	Ensure all cabling for proper connector contact. A bad connection can result in intermittent contact or dramatically increased resistance, which in turn can cause reduces output or noises unrelated to the signal.
	Improper power tap setting	Verify the power tap setting under the loudspeaker grille is appropriate for the installation and amplifier chosen.
Constant noise such as buzzing, hissing, or humming	A faulty electronic device in the signal chain	Loudspeakers cannot generate these sounds by themselves; you may have a faulty electronic device in the signal chain.
	Poor system grounding	Check and correct the system grounding, as required.
Poor low-frequency output	Out-of-polarity hookup between multiple loudspeakers	When two (2) loudspeakers are hooked up out of polarity (out of phase), the low frequencies cancel each other out. Try reversing the polarity of one (1) of the loudspeakers either by turning around a dual-banana plug at the amplifier or by reversing the tip/sleeve leads on the jack. Which ever condition results in greater low-frequency output is the in-polarity condition.

If these suggestions do not solve your problem, contact your nearest Electro-Voice dealer or Electro-Voice distributor.

6 Technical data

EVID C4.2 and EVID C8.2

Specification	EVID C4.2	EVID C8.2
Dimensions (depth x diam.)	6.9 in x 7.1 in (176 mm x 181 mm)	10.0 in x 10.6 in (255 mm x 270 mm)
Bezel diameter	8.3 in (210 mm)	11.8 in (300 mm)
Weight	6 lb (2.7 kg)	11 lb (5.0 kg)
Cabinet construction	Steel enclosure and UL94V-0 rated baffle and bezel	
LF transducer	4 in (100 mm) high-compliance driver (weatherized cone)	8 in (205 mm) high-compliance driver (weatherized cone)
HF transducer	0.75 in (19 mm) Ti-coated dome	1 in (25 mm) Ti-coated dome
Mounting system	Integrated 3-point toggle anchors	Integrated 4-point toggle anchors
Available colors	White (paintable)	
Grille construction	Powder-coated steel	
Acoustic design	Ported cabinet, two-way design, internally damped, w/passive crossover	
Frequency response	65 Hz–20 kHz	50 Hz–20 kHz
Power handling (@ 8Ω)	50 W (with overload protection)	75 W (with overload protection)
Coverage pattern	130° conical	110° conical
Sensitivity (SPL 1 W/1 m)	86 dB	91 dB
Input configuration	8Ω; 70V/100V	
70V/100V power taps	1.8 (70V only)/3.7/7.5/15/30 W	
Included accessories	Tile bridge, mounting ring	

EVID C8.2LP and EVID C8.2HC

Specification	EVID C8.2LP	EVID C8.2HC
Dimensions (depth x diam.)	7.0 in x 10.6 in (190 mm x 255 mm)	11.9 in x 12.6 in (303 mm x 320 mm)
Bezel diameter	11.8 in (300 mm)	13.8 in (350 mm)
Weight	11 lb (5.0 kg)	13.2 lb (6.0 kg)
Cabinet construction	Steel enclosure and UL94V-0 rated baffle and bezel	
LF transducer	8 in (205 mm) high-compliance driver (weatherized cone)	
HF transducer	1 in (25 mm) Ti-coated dome	
Mounting system	Integrated 4-point toggle anchors	
Available colors	White (paintable)	

EVID Ceiling Speaker Systems

Specification	EVID C8.2LP	EVID C8.2HC
Grille construction	Powder-coated steel	
Acoustic design	Ported cabinet, two-way design, internally damped, w/passive crossover	Ported cabinet, waveguide-coupled, two-way design,, internally damped, w/passive crossover
Frequency response	50 Hz–20 kHz	
Power handling (@ 8Ω)	75 W (with overload protection)	
Coverage pattern	110° conical	75° conical
Sensitivity (SPL 1 W/1 m)	91 dB	93 dB
Input configuration	8Ω; 70V/100V	
70V/100V power taps	1.8 (70V only)/3.7/7.5/15/30 W	7.5 (70V only)/15/30/60 W
Included accessories	Tile bridge, mounting ring	

EVID C10.1

Specification	EVID C10.1
Dimensions (depth x diam.)	11.9 in x 12.6 in (303 mm x 320 mm)
Bezel diameter	13.8 in (350 mm)
Weight	15.5 lb (7.0 kg)
Cabinet construction	Steel enclosure and UL94V-0 rated baffle and bezel
LF transducer	10 in (260 mm) high-compliance driver (weatherized cone)
Mounting system	Integrated 4-point toggle anchors
Available colors	White (paintable)
Grille construction	Powder-coated steel
Acoustic design	Ported cabinet, internally damped w/passive crossover
Frequency response	45 Hz–150 kHz
Power handling (@ 8Ω)	100 W (with overload protection)
Sensitivity (SPL 1 W/1 m)	94 dB
Input configuration	8Ω; 70V/100V
70V/100V power taps	7.5 (70V only)/15/30/60 W
Included accessories	Tile bridge, mounting ring

7 Appendices

7.1 Appendix A – Painting the Speaker

If the speaker is installed in an area where the interior design requires a color match, these speakers are simple to paint. The speakers can accommodate almost any type of latex or oil-based paint. The bezel/rim can be painted before installation or after mounting into the ceiling.

Painting Process

Clean the rim and grille with mineral spirits or other light solvent. Do not use harsh solvents such as gasoline, kerosene, acetone, or other chemicals. If you use these cleaners you may permanently damage the enclosure. Also, don't use abrasives products such as sandpaper or steel wool.

Either by rolling or spraying, apply two or more thin coats of paint. If you are spraying, hold the spray can at the angles shown in Figure 21.

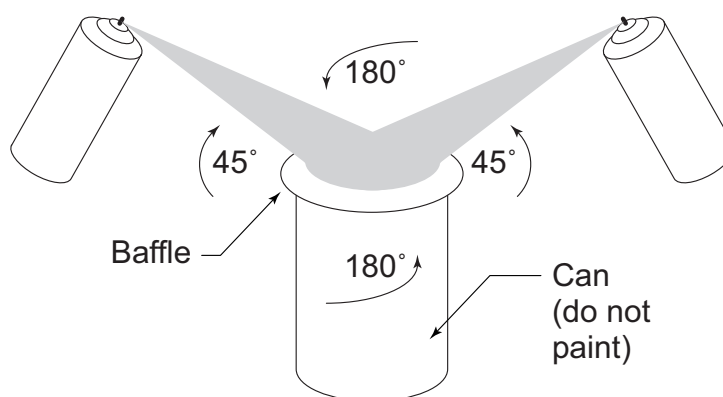

Figure 21: Spray-painting angles

If you are painting the grille also, you must first remove the internal grille cloth. Spray painting is strongly recommended. If the grille is rolled or brush painted, the grille may become clogged with paint and the sound quality will suffer. After the paint has dried, replace the internal grille cloth.

If you wish to paint the speaker along with the ceiling after installation, insert a plastic or cardboard paint shield into the front of the speaker to mask the drivers and internal baffle, paint the speaker, and then remove the shield. Do not paint the steel back can.

7.2 Appendix B – System Design Guide

7.2.1 Selecting and Positioning Ceiling Loudspeakers

Several key criteria determine the type and quantity of ceiling speakers to employ in a job. Specific EVID Ceiling Series models accommodate each job, depending on how these criteria are specified.

- Room size
- Coverage density desired
- Coverage angle specification of the speaker
- Ceiling height
- Audio program material being played

EVID Ceiling Speaker Systems

The information below, and the free design program downloadable from www.electrovoice.com, will help you optimize your EVID design. In the traditional approach to overhead distributed systems, loudspeakers are placed in a grid whose dimensions are dictated by the room height and the directivity of the speaker elements. Two basic placement patterns prevail: square spacing and hexagonal (or crisscross) spacing. See Figure 22.

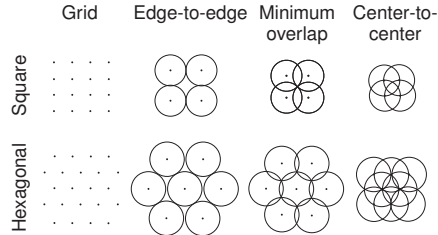

Figure 22: Coverage patterns

In addition to the spacing pattern, the designer must choose between three coverage density types, designated respectively as edge-to-edge, minimum overlap and center-to-center. The greater the overlap, the more uniform the coverage. The illustration below shows these various layout patterns.

7.2.2

Ceiling Systems: Size vs. Coverage

In the past, system designers usually specified 8-inch cone loudspeakers for distributed overhead systems, at least in part because they represented the traditional choice. EVID systems, however, allow for far more flexible options.

In many cases, you can achieve excellent results – at a significant savings – by using 4-inch transducers. This is especially true in jobs that do not require extended low-end response or high SPL levels. Four-inch transducers, such as those used in the C4.2, offer wider dispersion to allow for fewer speakers to be employed in the job. For example, due to its smaller cone diameter, the C4.2 exhibits significantly wider dispersion (130 degrees) than the C8.2 (110 degrees) at the -6 dB points.

The effect of this characteristic on an overhead system is indicated in Figure 23. In replacement applications where existing speaker positions are used, the C4.2 (shown in angle A) offers greater overlap and, thus, more uniform coverage than an older conventional 8-inch unit (shown in angle B). When specifying a new system, you can take advantage of the C4.2’s wider dispersion to decrease the number of speakers required to cover a given area. This will result in even greater savings.

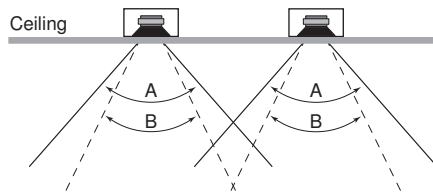

Figure 23: Size vs coverage

Of course, the C4.2 is somewhat less sensitive than the 8-inch C8.2. The difference is – 5 dB. The C4.2 will also have slightly reduced low-frequency capabilities below 65 Hz. However, neither of these factors is a significant problem in many distributed systems. The C4.2 is conservatively rated to handle 80 watts of continuous power equal to or greater than most other brands of 8-inch units, so its continuous SPL output will be more than adequate.

Moreover, its low-frequency output can easily be augmented with the addition of the C10.1 subwoofer. For these reasons, the C4.2 represents a great way for you to provide good audio coverage while maintaining a competitive edge in price quotes in installations that do not need the extended performance of the larger models.

Reverberant Rooms and High Ceilings

Situations arise, however, in which controlled coverage is more desirable than broad dispersion. Very large live spaces such as gymnasiums, convention centers, shopping mall atriums, and the like all benefit from more controlled sound projection. In such installations, the EVID C8.2HC is the best choice. Its 75-degree coverage pattern above 1 kHz provides more intelligibility in large, acoustically live spaces. It also has a high 93 dB sensitivity rating for optimum efficiency.

SPL Requirements: How Loud?

The EVID C8.2 is a great speaker to use when higher SPL is required. The fidelity and bandwidth of the unit is substantial and is ideal for applications requiring high quality foreground music reproduction. The C8.2 has substantial low frequency energy down below 60 Hz. This is more than sufficient for most applications.

Layout: How Many?

The Coverage Diameter by Ceiling Height chart shows the effective coverage diameter of the EVID models assuming a 4-foot listening plane height. Using these figures you can lay out a coverage pattern for the job after deciding the overlap criteria.

Model	8'	12'	20'	24'
C4.2	17'	34'	68'	85'
C8.2	11.5'	23'	45'	57'
C8.2HC	6.5'	12'	24'	30'
C10.1	180° coverage			

Table 7.1: Coverage Diameter by Ceiling Height

7.2.3

Use of Subwoofers

The C10.1 subwoofer can add considerable low frequency performance to any EVID installation. It is important to note that the C10.1 subwoofer depends on the ceiling and walls to properly load itself and to reinforce its bass output. Correct positioning is important to get maximum impact.

In smaller rooms when a single C10.1 is used, a center or near-center position is best. This gives the most even coverage. For larger rooms where more than one C10.1 are employed, the added effect of the room's walls can be used. In such a space, position the subwoofers evenly throughout the room and a few feet from the wall or corners. The added loading of the walls will enhance the response in these larger areas.

Bosch Security Systems, Inc

12000 Portland Avenue South

Burnsville MN 55337

USA

www.electrovoice.com

© Bosch Security Systems, Inc, 2016

Free Manuals Download Website

<http://myh66.com>

<http://usermanuals.us>

<http://www.somanuals.com>

<http://www.4manuals.cc>

<http://www.manual-lib.com>

<http://www.404manual.com>

<http://www.luxmanual.com>

<http://aubethermostatmanual.com>

Golf course search by state

<http://golfingnear.com>

Email search by domain

<http://emailbydomain.com>

Auto manuals search

<http://auto.somanuals.com>

TV manuals search

<http://tv.somanuals.com>