



**Bluetooth®**  
Wireless Headset

**Model EM-253**

**FCC and telephone company information**

**FCC Part 15**

This equipment has been tested and found to comply with the requirements for a Class B digital device under Part 15 of the Federal Communications Commission (FCC) rules. These requirements are intended to provide reasonable protection against harmful interference in a residential installation. This equipment generates, uses and can radiate radio frequency energy and, if not installed and used in accordance with the instructions, may cause harmful interference to radio communications. However, there is no guarantee that interference will not occur in a particular installation. If this equipment does cause harmful interference to radio or television reception, which can be determined by turning the equipment off and on, the user is encouraged to try to correct the interference by one or more of the following measures:

- Re-orient or relocate the receiving antenna.
- Increase the separation between the equipment and receiver.
- Connect the equipment into an outlet on a circuit different from that to which the receiver is connected.

consult the dealer or an experienced radio/TV technician for help.

Changes or modifications to this equipment not expressly approved by the party responsible for compliance could void the user's authority to operate the equipment.

**Drive safe**

Driving while talking on your mobile phone is dangerous, and illegal in many states.

Although this device enables drivers to conduct handsfree conversations, it is still dangerous to drive and use a mobile phone at the same time.

We recommend pulling over before making or answering calls, especially during adverse driving conditions. Please use your mobile phone, and our product responsibly while driving!

**Safety information**

- Check local laws regarding use of a mobile handset and wireless headset while driving. If you use the **Bluetooth Headset** while driving, ensure your attention and focus remains on your driving.
- Observe all signs in the designated areas where some electronic devices or RF radio products are required to be switched off. These could include airplanes, hospitals, blasting areas, and potentially explosive atmospheres.

**Location of controls**

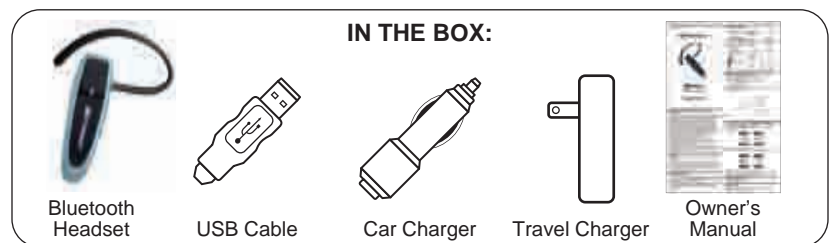
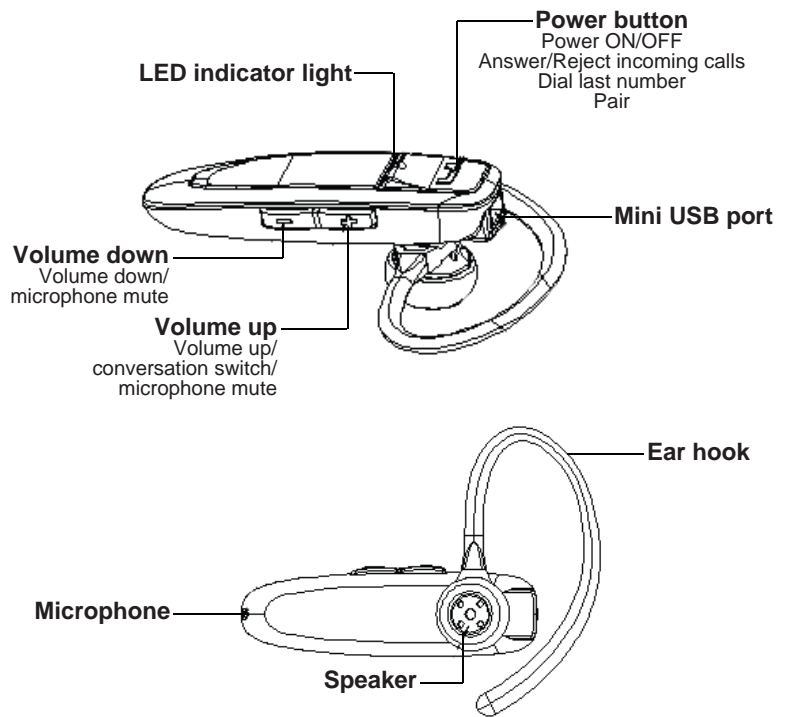

**1 Charging the Bluetooth headset**

1. Connect the USB cable to the charging socket on the handset.
2. Connect the USB cable to:
  - AC Charger, and plug into a wall (A/C) outlet.
  - Computer's USB port.
  - Car Charger.
3. The RED LED indicator light turns on.
4. The RED LED indicator light shuts off when the headset is fully charged. (approximately 2 hours)

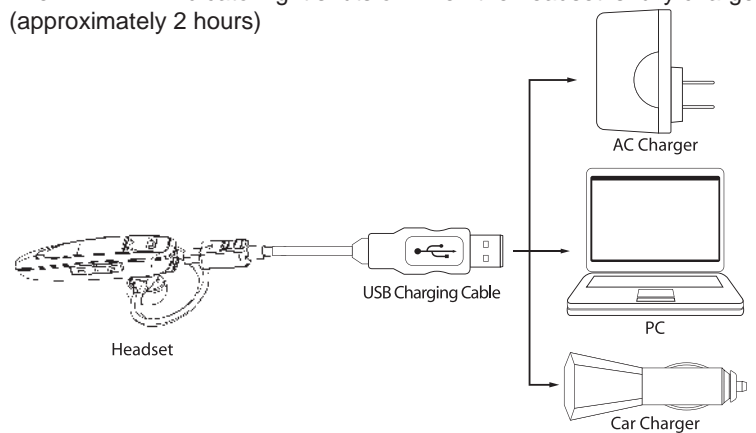

**NOTE:** Make sure you charge your headset for two hours before using it for the first time.

**2 Pairing the headset with a Bluetooth enabled phone**

1. Keep your **Bluetooth Headset** and mobile phone within 3 feet of each other during pairing.
2. Make sure the **Bluetooth Headset** is turned off.
3. Press and hold the **[POWER]** button until the RED and BLUE lights flash alternately.

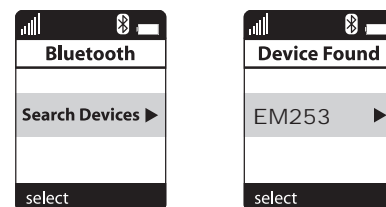

4. Set the phone to search for bluetooth devices.
5. When the phone finds the headset, confirm by selecting EM252 from the list.

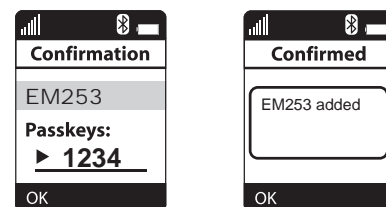

## 2 Pairing the headset with a Bluetooth enabled phone

- Enter passcode "1234" when prompted by the phone.
- If the pairing was successful, the indicator light flashes a low steady blue. You are now ready to make and receive calls.

## 3 Using your Bluetooth headset

### Powering ON/OFF

- To turn ON, press and hold the [POWER] button until the BLUE LED indicator light turns on.
- To turn OFF, press and hold the [POWER] button until the BLUE LED indicator light shuts off.

### Answering/Ending a call

- To answer a call, press the [POWER] button once.
- To end a call, press the [POWER] button once.

### To make a call

Dial the number and press the send button from your phone, the call is automatically transferred to the headset.

### Rejecting an incoming call

To reject an incoming call, press and hold the [POWER] button until you hear the confirmation tone.

### Redialing the last number called (Dependent on your phone supporting this feature)

Press the [POWER] button twice.

### Voice dial (Dependent on your phone supporting this feature)

Press and hold the [VOLUME DOWN] button until you hear the confirmation tone, and then say a name from your phone's contact list.

### Adjusting volume

Press the [VOLUME DOWN] or [VOLUME UP] button to adjust the volume to the desired level.

### Transferring calls

To transfer calls between your **Bluetooth Headset** and phone during a conversation, press and hold the [VOLUME UP] button until you hear the confirmation tone. To transfer the call back to the **Bluetooth Headset** press and hold the [VOLUME UP] button once again, until you hear the confirmation tone.

### Microphone mute

Press and hold the [VOLUME DOWN] and [VOLUME UP] buttons simultaneously until you hear the confirmation tone. The microphone of your **Bluetooth Headset** will be mute. While it is in mute mode, your **Bluetooth Headset** will "beep" every 5 seconds. To cancel mute mode press and hold the [VOLUME DOWN] and [VOLUME UP] buttons once again, until you hear the confirmation tone.

## Wearing your Bluetooth headset

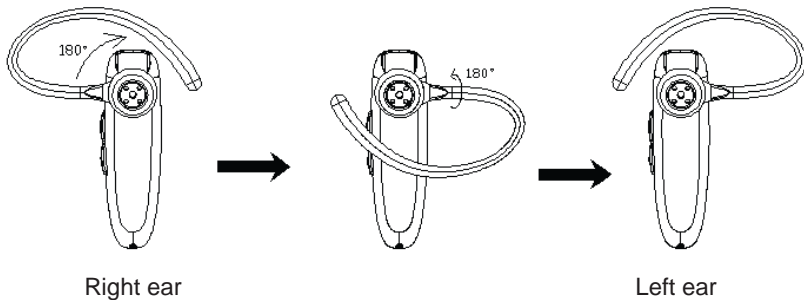

## Product Maintenance

- Power off this product when not in use.
- DO NOT expose this product to water or other liquids.
- DO NOT use abrasive cleaning solvents to clean the **Bluetooth Headset**.
- If you will not use the **Bluetooth Headset** for long periods, be sure to store it in a dry place, free from extreme temperature, humidity and dust.

## Warranty information

### 90 Day Limited Warranty

In the unlikely event that this product is defective, or does not perform properly, you may within ninety (90) days from your original date of purchase return it to the authorized service center for repair or exchange.

#### TO OBTAIN WARRANTY SERVICE:

- Provide proof of the date of purchase within the package (Dated bill of sale).
- Prepay all shipping costs to the authorized service center, and remember to insure your return.
- Include a return shipping address (no P.O. Boxes), a telephone contact number, and the defective unit within the package.
- Describe the defect or reason you are returning the product.

## Warranty information

Your product will be repaired or replaced, at our option, for the same or similar model of equal value if examination by the service center determines this product is defective. Products received damaged as a result of shipping will require you to file a claim with the carrier.

The shipping address of the authorized service center is:

**Southern Telecom Inc.**  
**ATTN: Returns Department**  
**14-C 53rd Street**  
**Brooklyn, NY 11232**

Should you have any questions or problems concerning this product, please contact our customer service department, toll free at:

1-877-768-8483  
Monday - Thursday: 9AM - 5PM (EST)  
Friday: 9AM - 3PM (EST)

or via e-mail at [cs@emersonphones.com](mailto:cs@emersonphones.com). To obtain service after the warranty period, please e-mail [cs@emersonphones.com](mailto:cs@emersonphones.com) with product information, date of purchase and nature of the problem. Customer service will reply to the e-mail with service instructions.

#### Warranty service not provided

This warranty does not cover damage resulting from accident, misuse, abuse, improper installation or operation, lack of reasonable care, and unauthorized modification. This warranty is voided in the event any unauthorized person opens, alters or repairs this product. All products being returned to the authorized service center for repair must be suitably packaged.

#### Limitation of Warranty:

- THE WARRANTY STATED ABOVE IS THE ONLY WARRANTY APPLICABLE TO THIS PRODUCT. ALL OTHER WARRANTIES, EXPRESS OR IMPLIED (INCLUDING ALL IMPLIED WARRANTIES OF MERCHANTABILITY OR FITNESS FOR A PARTICULAR PURPOSE) ARE HEREBY DISCLAIMED. NO VERBAL OR WRITTEN INFORMATION GIVEN BY SOUTHERN TELECOM INC. IT'S AGENTS, EMPLOYEES SHALL CREATE A GUARANTY OR IN ANY WAY INCREASE THE SCOPE OF THIS WARRANTY.
- REPAIR OR REPLACEMENT AS PROVIDED UNDER THIS WARRANTY IS THE EXCLUSIVE REMEDY OF THE CONSUMER. SOUTHERN TELECOM INC. SHALL NOT BE LIABLE FOR INCIDENTAL OR CONSEQUENTIAL DAMAGES RESULTING FROM THE USE OF THIS PRODUCT OR ARISING OUT OF ANY BREACH OF ANY EXPRESS OR IMPLIED WARRANTY ON THIS PRODUCT. THIS DISCLAIMER OF WARRANTIES AND LIMITED WARRANTY ARE GOVERNED BY THE LAWS OF THE STATE OF NEW YORK. EXCEPT TO THE EXTENT PROHIBITED BY APPLICABLE LAW, ANY IMPLIED WARRANTY OF MERCHANTABILITY OR FITNESS FOR A PARTICULAR PURPOSE THIS PRODUCT IS LIMITED TO THE APPLICABLE WARRANTY ON PERIOD SET FORTH ABOVE.

Some states do not allow the exclusion nor limitation of incidental or consequential damages, or limitations on how long an implied warranty lasts so the above limitations or exclusions may not apply to you. This warranty gives you specific legal rights, and you also may have other rights that vary from state to state.

[www.emersonphones.com](http://www.emersonphones.com)

Manufactured by Southern Telecom Inc. Brooklyn NY. 11232  
Emerson and G-Clef logo are registered trademarks of  
Emerson Radio Corp. Parsippany, New Jersey USA.  
© 2009 AIT Inc. All rights reserved.

The Bluetooth® word mark and logos are owned by the Bluetooth SIG, Inc.

## Free Manuals Download Website

<http://myh66.com>

<http://usermanuals.us>

<http://www.somanuals.com>

<http://www.4manuals.cc>

<http://www.manual-lib.com>

<http://www.404manual.com>

<http://www.luxmanual.com>

<http://aubethermostatmanual.com>

Golf course search by state

<http://golfingnear.com>

Email search by domain

<http://emailbydomain.com>

Auto manuals search

<http://auto.somanuals.com>

TV manuals search

<http://tv.somanuals.com>