

July 2019

6350 Series Pilots for Pilot-Operated Pressure Reducing Regulators

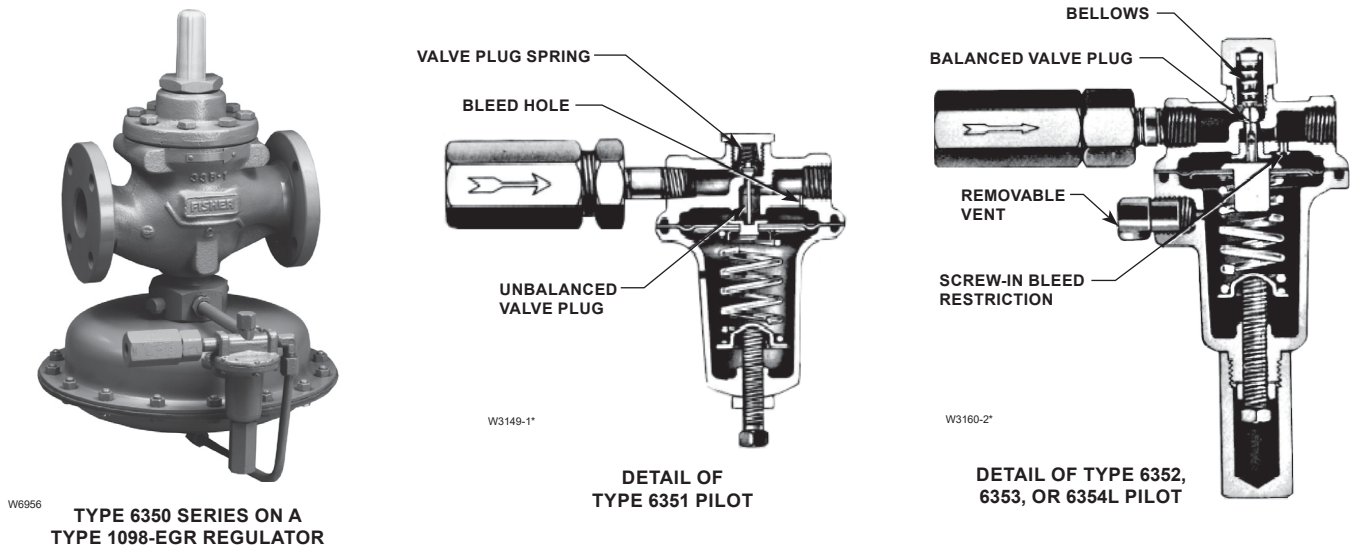

Figure 1. 6350 Series Pressure Reducing Pilot Constructions

Introduction

Scope of the Manual

This manual provides installation, startup, maintenance, and parts ordering information for the 6350 Series pilots used together with Pilot-Operated Pressure Reducing Regulators in low pressure applications.

For information on mounting on Pilot-operated Regulators, refer to full product literature:

Type 1098-EGR: D100339X012

Type EZL: D103091X012

Product Description

The 6350 Series pilots have been designed to ensure maximum pressure control accuracy and fast response in a wide variety of applications: natural gas distribution systems; fuel gas supply to industrial boilers, furnaces, ovens, and mixers; and large commercial/industrial establishments such as shopping centers and schools. They can also be used in plant air and in liquid service.

6350 Series

Specifications

The Specifications section lists pressure limitations and other specifications for various models of 6350 Series pilots. Please note that the pilot control spring range is displayed on the pilot spring case, and the pilot restriction code is stamped on the pilot body (S=standard gain, L=low gain, H=high gain).

<p>Maximum Pilot Supply Pressure⁽¹⁾⁽²⁾ 600 psig / 41.4 bar</p> <p>Outlet Pressure Ranges See Table 1</p> <p>Process Temperature Capabilities⁽¹⁾ Standard Elastomers: -20 to 150°F / -29 to 66°C High-Temperature Elastomers: 0 to 300°F / -18 to 149°C, except 0 to 180°F / -18 to 82°C for water service</p>	<p>Pilot Restriction Code S - Standard gain L - Low Gain H - High gain</p> <p>Connections⁽³⁾ 1/4 NPT internal</p> <p>Approximate Weight 2 pounds / 1 kg</p>
--	--

1. The pressure/temperature limits in this instruction manual or any applicable standard limitation should not be exceeded.
2. For stability or overpressure protection, a reducing regulator may be installed upstream of the pilot according to the Installation section.
3. Connections threaded to various national or international standards can usually be supplied. Contact your local Sales Office.

Table 1. Outlet Pressure Ranges

PILOT TYPE	OUTLET (CONTROL) PRESSURE RANGE		SPRING COLOR	SPRING PART NUMBER
6351	3 to 20 psig 5 to 35 psig 35 to 100 psig	0.21 to 1.4 bar 0.35 to 2.4 bar 2.41 to 6.9 bar	Green Silver Red	1B986027212 1B788327022 1K748527202
6352	14 in. w.c. to 2 psig 2 to 10 psig	35 mbar to 0.14 bar 0.14 to 0.69 bar	Yellow Black	14A9672X012 14A9673X012
6353	3 to 40 psig 35 to 125 psig	0.21 to 2.8 bar 2.4 to 8.6 bar	Yellow Red	1E392527022 1K748527202
6354L ⁽¹⁾ 6354M ⁽²⁾ 6354H	85 to 200 psig ⁽¹⁾ 175 to 220 psig ⁽²⁾ 200 to 300 psig ⁽²⁾	5.9 to 13.8 bar ⁽¹⁾ 12.1 to 15.2 bar ⁽²⁾ 13.8 to 20.7 bar ⁽²⁾	Blue Blue Green	1L346127142 1L346127142 15A9258X012

1. Without diaphragm limiter.
2. With diaphragm limiter.

Principle of Operation

Pilot-operated regulators use inlet pressure as the operating medium, which is reduced through pilot operation to load the actuator diaphragm. Outlet or downstream pressure opposes loading pressure in the actuator and also opposes the pilot control spring.

In operation, assume that outlet pressure is below the pilot control setting. Control spring force on the pilot diaphragm thus opens the pilot valve plug providing additional loading pressure to the actuator diaphragm. This loading pressure forces the actuator stem forward, opening the main valve plug via a bump connection. The upward motion of the plug allows gas to flow through the cage into the downstream system.

When downstream demand has been satisfied, outlet pressure will increase, acting on the pilot and actuator diaphragm. This pressure exceeds the pilot control spring setting, moving the pilot diaphragm away and

letting the valve plug spring (Type 6351) or bellows (Types 6352 through 6354M pilots) close the pilot valve plug (unbalanced in the Type 6351 but balanced in the Types 6352 through 6354M pilots). Excess loading pressure on the actuator diaphragm escapes downstream through the bleed hole (Type 6351 pilot) or restriction (Types 6352 through 6354M pilots).

Reduced actuator loading pressure permits the main valve to close. The combination of main valve spring force and valve plug unbalance provides positive valve plug shutoff against the port and upper seals.

All 6350 Series pilots have an internal check valve that allows loading pressure to bleed downstream at approximately 25 psig / 1.7 bar differential across the actuator diaphragm.

Installation and Startup

1. Use qualified personnel when installing, operating and maintaining pilots. Before installing, inspect pilot and tubing, for any shipment damage or foreign material that may have collected during crating and shipment. Make certain that body is clean and the pipelines are free of foreign material.

WARNING

In hazardous or flammable gas service, vented gas may accumulate, and cause personal injury, death, or property damage due to fire or explosion.

Vent a regulator in hazardous gas service to a remote, safe location away from air intakes or any hazardous location. The vent line or stack opening must be protected against condensation or clogging.

2. To keep the pilot spring case vent from being plugged or the spring case from collecting moisture, corrosive chemicals, or other foreign material, point the vent down or otherwise protect it. To remotely vent the standard pilot, remove the vent and install obstruction-free tubing or piping into the 1/4 NPT vent tapping. Provide protection on a remote vent by installing a screened vent cap into the remote end of the vent pipe.
3. Run a 3/8 in. / 9.5 mm outer diameter or larger pilot supply line from the upstream pipeline to the filter inlet. Do not make the upstream pipeline connection in a turbulent area, such as near a nipple, swage, or elbow. If the maximum pilot inlet pressure could exceed the pilot rating, install a separate reducing regulator in the pilot supply line. Install a hand valve in the pilot supply line, and provide vent valves to properly isolate and relieve the pressure from the regulator.

CAUTION

Introduce pilot supply pressure into the regulator before introducing any downstream pressure, or internal damage may occur due to reverse pressurization of the pilot and main valve components.

4. Pressure setting of pilot control spring: Turning the adjusting screw clockwise into the spring case increases the spring compression and pressure setting. Turning the adjusting screw counterclockwise decreases the spring compression and pressure setting.

Pilot Adjustment

To adjust standard 6350 Series pilots: loosen the locknut and turn the adjusting screw. Then tighten the locknut to maintain the adjustment position. A closing cap must be removed before adjustment and replaced afterward.

WARNING

To avoid possible personal injury from a pressure-loaded pilot, carefully vent the spring case before removing the closing cap. Otherwise, trapped loading pressure could forcefully eject the freed closing cap.

Maintenance

Pilot parts are subject to normal wear and must be inspected and replaced as necessary. The frequency of inspection and replacement of parts depends upon the severity of service conditions or the requirements of local, state, and federal regulations. Due to the care Fisher™ takes in meeting all manufacturing requirements (heat treating, dimensional tolerances, etc.), use only replacement parts manufactured or furnished by Fisher.

All O-rings, gaskets, and seals should be lubricated with a good grade of general purpose grease and installed gently rather than forced into position. Be certain that the nameplates are updated to accurately indicate any field changes in equipment, materials, service conditions, or pressure settings.

WARNING

To avoid personal injury resulting from sudden release of pressure, isolate the regulator from all pressure and cautiously release trapped pressure from the regulator before attempting disassembly.

Type 6351 Pilot

Perform this procedure if changing the control spring for one of a different range, or if inspecting, cleaning, or replacing any other pilot parts. Pilot key numbers are referenced in Figure 2.

Note

The body assembly (key 1) may remain on the pipe nipple (key 22, Figure 2) unless the entire pilot is replaced.

1. To gain access to the diaphragm assembly (key 7), control spring (key 9), or spring seat (key 8), loosen the locknut (key 11), and turn the adjusting screw (key 10) out until compression is removed from the spring. Remove the machine screws (key 12), and separate the body assembly from the spring case.
2. Inspect the removed parts and replace as necessary. Ensure the registration and bleed holes in the pilot body are free of debris. After assembly, make sure of the proper control spring setting according to the Startup section and remark the spring case if necessary.
3. To replace the valve plug (key 4), remove the body plug (key 3) to let the valve spring (key 6) and inner valve assembly (key 4) drop freely from the body (key 1). Inspect the removed parts, replace if necessary. Make sure the plug seating surfaces are free from debris. Inspect body plug O-ring, replace if necessary. Type 6351 pilots manufactured before May 1999 need to have the body plug gasket and the body plug replaced with a new body plug assembly (key 3), which includes the body plug and the body plug O-ring. Install the body plug O-ring over the body plug. Stack the valve spring (key 6) and the inner valve assembly (key 4) on the body plug assembly (key 3), and install the body plug assembly with stacked parts into the body (key 1).

Types 6352 through 6354M Pilots

Perform this procedure if changing the control spring for one of a different range, or if inspecting, cleaning, or replacing any other pilot parts. Pilot part key numbers are referenced in Figure 3.

Note

The body (key 1) may remain on the pipe nipple (key 21, Figure 3) unless the entire pilot is replaced.

1. To gain access to the diaphragm assembly (key 5), diaphragm limiter (key 23) if used, control spring (key 6), restriction (key 22), stem guide (key 8), or spring seat (key 7), remove the closing cap (key 11), loosen the locknut (key 10), and turn the adjusting screw (key 9) counterclockwise until compression is removed from the spring. Remove the machine screws (key 14), and separate the body from the spring case (key 2).
2. Inspect the removed parts, and replace as necessary. Make sure the restriction and the registration hole in the body are free from debris. After assembly, make sure of the proper control spring setting according to the Startup section, and remark the spring case if necessary.
3. To replace the valve plug (key 4) or bellows O-ring (key 17), remove the body plug (key 3) and body plug gasket (key 12). Be careful to keep the bellows assembly (key 16) from falling out and possibly getting lost while removing the valve plug. Inspect the removed parts, and replace as necessary. Make sure the valve plug seating surfaces are free from debris.

Parts Ordering

Each 6350 Series pilot is assigned a serial number or FS number which can be found on the nameplates. Refer to this number when contacting your local Sales Office for assistance, or when ordering replacement parts.

When ordering a replacement part, be sure to include the complete 11-character part number from the following parts list. Some commonly used trim packages can be ordered according to the 11-character assembly number given in the parts kits listed in the Parts List.

Parts List

Type 6351 Pilot (Figure 2)

Key	Description	Part Number	Key	Description	Part Number
	Parts Kit (includes keys 3, 4, 6, 7 and for the P590 Series filter, keys 2 and 7)	R6351X00012	22	Pipe Nipple, Standard and Corrosive service, Galvanized plated steel (use with P590 Series) Steel (NACE)	1C488226232 1C4882X0032
1	Body Assembly Aluminum with brass bushing Aluminum with Stainless steel bushing (NACE) Stainless steel with Stainless steel bushing	1B7971X0092 1B7971X0342 1B7971X0122	24	Filter P590 Series (standard) P590 Series for NACE service	Type P514-1 Type P513-1
2	Bonnet Aluminum with closing cap	25A6220X012	28	Closing Cap Aluminum bonnet (plastic cap)	23B9152X012
3	Body Plug Assembly (includes body plug and O-ring) Aluminum body plug with Nitrile (NBR) O-ring with Fluorocarbon (FKM) O-ring Stainless steel body plug with Nitrile (NBR) O-ring with Fluorocarbon (FKM) O-ring	18B6542X022 18B6542X042 18B6542X052 18B6542X062	35	Vent Assembly	Type Y602-12
4	Inner Valve Assembly Nitrile (NBR) with brass stem Nitrile (NBR) with Stainless steel stem Nitrile (NBR) with Stainless steel stem (NACE) Fluorocarbon (FKM) with Stainless steel stem Fluorocarbon (FKM) with brass stem	20B9389X012 20B9389X022 20B9389X022 20B9389X042 29B9389X032	42	Relief Valve Assembly Aluminum/302 Stainless steel (NACE) Aluminum/Stainless steel (Types S301D and S301F) All other assemblies	16A5929X042 16A5929X012 16A5929X022
6	Valve Spring For brass and Stainless steel stems For Stainless steel stem (NACE)	1B797937022 19A2860X012	43	Closing Cap Gasket Types S301D and S301F NPT TAP	15A6218X012
7*	Diaphragm Assembly (includes plated steel diaphragm plate) Nitrile (NBR) diaphragm and Aluminum pusher post Nitrile (NBR) diaphragm and Stainless steel pusher post Fluorocarbon (FKM) diaphragm and Aluminum pusher post	1B7980000B2 1B7980X00A2 1B7980000C2			
8	Upper Spring Seat	1B798525062			
9	Control Spring, plated steel 2 to 10 psig / 0.14 to 0.69 bar range, (Types S301F and S301D) 2 to 20 psig / 0.14 to 1.4 bar range, (Types S301F and S301D) 3 to 20 psig / 0.21 to 1.4 bar range, Green 5 to 35 psig / 0.35 to 2.4 bar range, Silver 35 to 100 psig / 2.4 to 6.9 bar range, Red	14A9673X012 1B788327022 1B986027212 1B788327022 1K748527202			
10	Adjusting Screw Aluminum bonnet Aluminum bonnet with 2 to 10 psi / 0.14 to 0.69 bar spring range	10B7192X012 1H305028982			
11	Locknut, plated steel (not used with Type 661) Aluminum Aluminum bonnet with 2 to 10 psi / 0.14 to 0.69 bar spring range	1A946324122 1C724018992			
12	Machine Screw, steel (6 required)	T13305T0012			
13	Hex Lock Plate, Aluminum	10B2695X012			
14	Threaded Lock Plate, Aluminum	10B2696X012			

Types 6352, 6353, 6354L, 6354M, and 6354H Pilots (Figure 3)

Key	Description	Part Number
	Parts kit (included are: valve plug, key 4; Diaphragm assembly, key 5; body plug gasket, key 12; Bellows O-ring, key 17; closing cap gasket, key 20; and for the P590 Series filter, filter element, key 2; and gasket, key 7)	
	Type 6352	R6352X00012
	Type 6353	R6353X00012
	Type 6354	R6354X00012
1	Pilot Body Aluminum Aluminum with 50 psig / 3.4 bar Type 1806H Relief Stainless steel Stainless steel with 50 psig / 3.4 bar Type 1806H relief	35A6228X012 17A8075X012 39A5971X012 17A8075X022
2	Spring Case Aluminum Stainless steel	25A6220X012 28A9277X012
3	Body Plug Aluminum 316 Stainless steel	15A6221X012 15A6221X042
4	Valve Plug and Stem Assembly Nitrile (NBR) disk with Stainless steel stem (standard) Nitrile (NBR) disk with 316 Stainless steel stem (NACE) Fluorocarbon (FKM) with Stainless steel stem (for use in Oxygen service) Fluorocarbon (FKM) disk with 316 Stainless steel stem (NACE)	15A6207X012 15A6207X052 15A6207X042 15A6207X112

- continued -

*Recommended spare part.

1. NACE International Standard MR0175.

2. Part included in trim package assembly can be ordered according to the parts kit trim package.

6350 Series

Types 6352, 6353, 6354L, 6354M, and 6354H Pilots (Figure 3) (continued)

Key	Description	Part Number	Key	Description	Part Number
5	Diaphragm Assembly		13	Vent Assembly	Type Y602-12
	Type 6352, Nitrile (NBR)	15A6216X012	14	Machine Screw (6 required)	
	Type 6353, Nitrile (NBR)	15A6216X022		Aluminum	10B6189X022
	Type 6353, Fluorocarbon (FKM)	15A6216X092		Stainless steel	1V4360X0022
	Type 6353, Fluorocarbon (FKM) (for use in Oxygen service)	15A6216X162	15	Relief Valve Assembly	
	Type 6354, Neoprene (CR)	15A6216X032		25 psig / 1.7 bar	16A5929X052
	Type 6354, Fluorocarbon (FKM)	15A6216X152		25 psig / 1.7 bar (NACE)	16A5929X042
	Type 6352 (NACE), Nitrile (NBR)	15A6216X552		25 psig / 1.7 bar (for Oxygen service)	16A5929X032
	Type 6353 (NACE), Nitrile (NBR)	15A6216X542		25 psig / 1.7 bar (Stainless steel)	16A5929X072
	Type 6353 (NACE), Fluorocarbon (FKM)	15A6216X562	16*	Bellows Assembly	
	Type 6354 (NACE), Neoprene (CR)	15A6216X572		Standard for all except in Oxygen service	15A6202X032
	Type 6354 (NACE), Fluorocarbon (FKM)	15A6216X582		For use in Oxygen service	15A6202X022
6	Control Spring		17*	O-ring	
	Type 6352			Standard for all except in Oxygen service	1D682506992
	14 in. w.c. to 2 psig / 35 mbar to 0.14 bar	14A9672X012		For use in Oxygen service, Fluorocarbon (FKM)	1D6825X0012
	2 to 10 psig / 0.14 to 0.69 bar, Black	14A9673X012	19	Filter	
	DVGW 4 to 10 psig / 0.28 to 0.69 bar	14A9673X012		P590 Series (standard)	Type P514-1
	Type 6353			P590 Series for NACE service	Type P513-1
	3 to 40 psig / 0.21 to 2.8 bar	1E392527022	20	Closing Cap Gasket	15A6218X012
	35 to 125 psig / 2.4 to 8.6 bar	1K748527202	21	Pipe Nipple	
	DVGW 10 to 40 psig / 0.69 to 2.8 bar	1E392527022		For standard and corrosive service	1C488226232
	DVGW 40 to 58 psig / 2.8 to 4.0 bar	1K748527022		For NACE service	1C4882X0032
	Type 6354L			For corrosive NACE service	1C488238982
	85 to 200 psig / 5.9 to 13.8 bar	1L346127142	22	Restriction	
	Type 6354M			Standard	17A2030X012
	175 to 220 psig / 12.1 to 15.2 bar	1L346127142		High	17A2029X012
	Type 6354H		23	Diaphragm Limiter	
	200 to 300 psig / 13.8 to 20.7 bar	15A9258X012		Aluminum	15A9259X012
7	Spring Seat			Stainless steel	10B4407X012
	Type 6352 or 6353	1B798525062	26	NACE Tag	19A6034X012
	Type 6354L, 6354M, or 6354H	1K155828982	27	Tag Wire	1U7581X0022
8	Stem Guide				
	416 Stainless steel (standard)	15A6222X012			
	410 Stainless steel (NACE)	15A6222X022			
9	Adjusting Screw				
	Type 6352	10B3692X012			
	Type 6353	10B7192X012			
	Type 6354	10B6190X012			
10	Locknut				
	Type 6352	1C724018992			
	Type 6353 or 6354	1A946324122			
11	Closing Cap				
	Aluminum spring case	23B9152X012			
	Stainless steel spring case	1H2369X0032			
12	Body Plug Gasket / O-ring				
	For Aluminum, composition	1C495704022			
	For Stainless steel body, Nitrile (NBR)	1F113906992			
	For Stainless steel body, Fluorocarbon (FKM)	1N463906382			

The following parts are for Type 6353 only (not shown in Figure 3)

Key	Description	Part Number
28	Packing Bonnet	1L449635072
29	Packing Nut	0P077624102
30	Handwheel	1L217544992
31	Washer	1A329128982
32	Screw	1E985428982
33	Packing Spring	1F125437012
34	Packing Box Gasket	1B487099202
35*	Packing Follower	1K885035072
36*	Male Adaptor	1F124801012
37*	Female Adaptor	1F124401012
38*	Packing Washer	1F125236042
39*	Packing Ring (3 required)	1C752601012
40	Adjusting Screw	21B5621X012

*Recommended spare part.

1. NACE International Standard MR0175.

2. Part included in trim package assembly can be ordered according to the parts kit trim package.

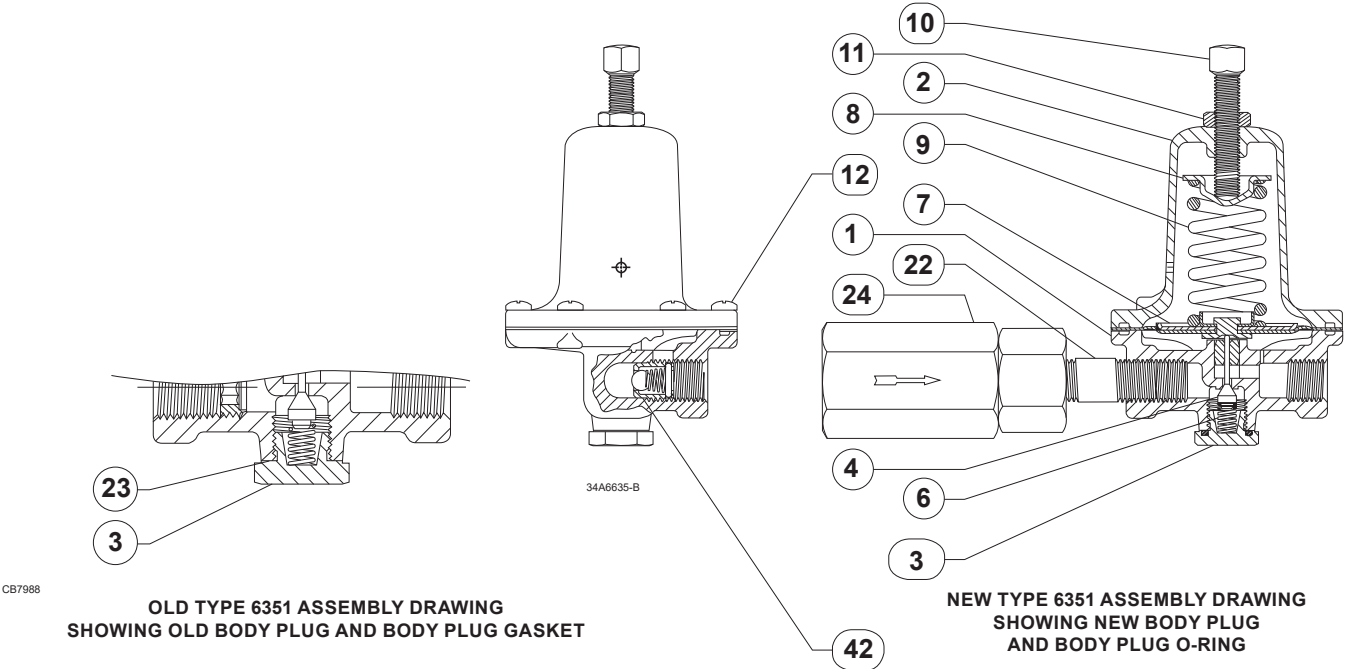

Figure 2. Type 6351 Pilot Assembly

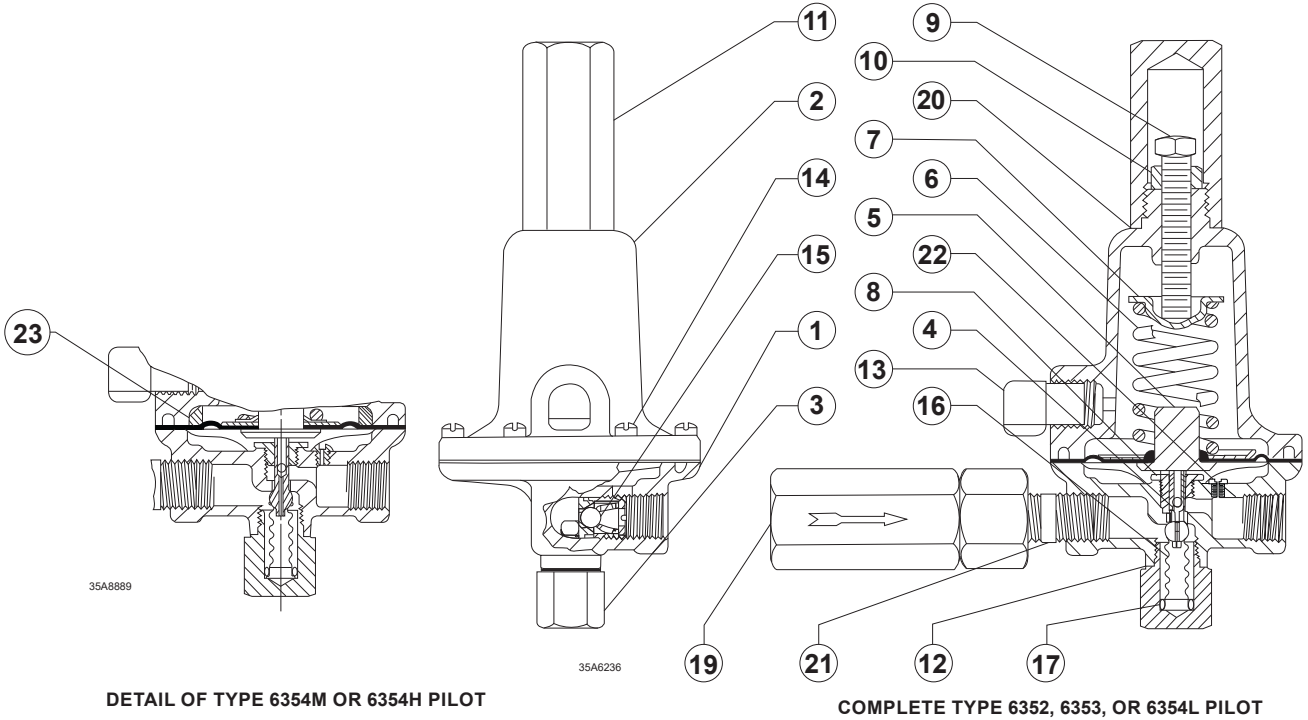

Figure 3. Types 6352 through 6354H Pilot Assemblies

6350 Series

✉ Webadmin.Regulators@emerson.com

🔍 Fisher.com

📘 Facebook.com/EmersonAutomationSolutions

🌐 LinkedIn.com/company/emerson-automation-solutions

🐦 Twitter.com/emr_automation

Emerson Automation Solutions

Americas

McKinney, Texas 75070 USA
T +1 800 558 5853
+1 972 548 3574

Europe

Bologna 40013, Italy
T +39 051 419 0611

Asia Pacific

Singapore 128461, Singapore
T +65 6777 8211

Middle East and Africa

Dubai, United Arab Emirates
T +971 4 811 8100

D103153X012 © 2008, 2019 Emerson Process Management Regulator Technologies, Inc. All rights reserved. 07/19.

The Emerson logo is a trademark and service mark of Emerson Electric Co. All other marks are the property of their prospective owners. Fisher™ is a mark owned by Fisher Controls International LLC, a business of Emerson Automation Solutions.

The contents of this publication are presented for informational purposes only, and while every effort has been made to ensure their accuracy, they are not to be construed as warranties or guarantees, express or implied, regarding the products or services described herein or their use or applicability. All sales are governed by our terms and conditions, which are available upon request. We reserve the right to modify or improve the designs or specifications of such products at any time without notice.

Emerson Process Management Regulator Technologies, Inc does not assume responsibility for the selection, use or maintenance of any product. Responsibility for proper selection, use and maintenance of any Emerson Process Management Regulator Technologies, Inc. product remains solely with the purchaser.



Free Manuals Download Website

<http://myh66.com>

<http://usermanuals.us>

<http://www.somanuals.com>

<http://www.4manuals.cc>

<http://www.manual-lib.com>

<http://www.404manual.com>

<http://www.luxmanual.com>

<http://aubethermostatmanual.com>

Golf course search by state

<http://golfingnear.com>

Email search by domain

<http://emailbydomain.com>

Auto manuals search

<http://auto.somanuals.com>

TV manuals search

<http://tv.somanuals.com>