

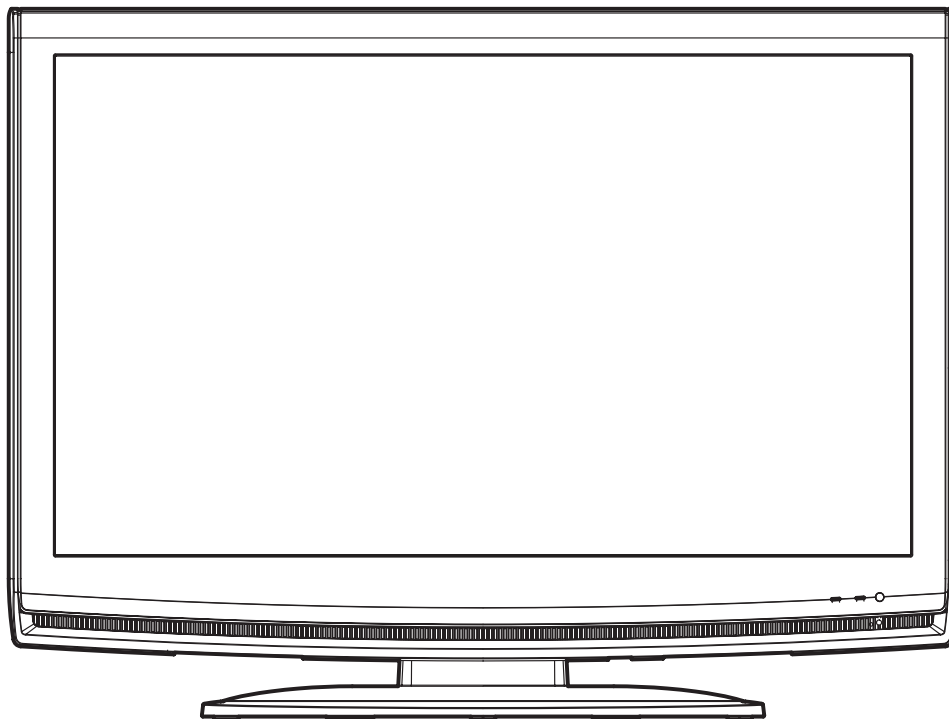

EMERSON AND THE G-CLEF LOGO ARE REGISTERED TRADEMARKS
OF EMERSON RADIO CORP., PARSIPPANY, NEW JERSEY, U.S.A.

SERVICE MANUAL

32" COLOR LCD TELEVISION LC320EM9



IMPORTANT SAFETY NOTICE

Proper service and repair is important to the safe, reliable operation of all Funai Equipment. The service procedures recommended by Funai and described in this service manual are effective methods of performing service operations. Some of these service special tools should be used when and as recommended.

It is important to note that this service manual contains various CAUTIONS and NOTICES which should be carefully read in order to minimize the risk of personal injury to service personnel. The possibility exists that improper service methods may damage the equipment. It also is important to understand that these CAUTIONS and NOTICES ARE NOT EXHAUSTIVE. Funai could not possibly know, evaluate and advice the service trade of all conceivable ways in which service might be done or of the possible hazardous consequences of each way. Consequently, Funai has not undertaken any such broad evaluation. Accordingly, a servicer who uses a service procedure or tool which is not recommended by Funai must first use all precautions thoroughly so that neither his safety nor the safe operation of the equipment will be jeopardized by the service method selected.

TABLE OF CONTENTS

Specifications	1-1
Important Safety Precautions	2-1
Standard Notes for Servicing	3-1
Cabinet Disassembly Instructions	4-1
Electrical Adjustment Instructions	5-1
How to initialize the LCD Television	6-1
Block Diagrams	7-1
Schematic Diagrams / CBA's and Test Points	8-1
Waveforms	9-1
Wiring Diagram	10-1
Exploded Views	11-1
Mechanical Parts List	12-1
Electrical Parts List	13-1

The LCD panel is manufactured to provide many years of useful life. Occasionally a few non active pixels may appear as a tiny spec of color. This is not to be considered a defect in the LCD screen.

SPECIFICATIONS

< TUNER / NTSC >

ANT. Input ----- 75 Ω Unbal., F type

Description	Condition	Unit	Nominal	Limit
1. AFT Pull-in Range	---	MHz	±2.3	±2.1
2. Synchronizing Sens.	TV.ch.4	dBμ	---	20
	CA.ch.31	dBμ	---	20
	CA.ch.87	dBμ	---	23

< TUNER / ATSC >

Description	Condition	Unit	Nominal	Limit
1. Received Freq. Range (-28dBm)	---	kHz	---	±100
2. ATSC Dynamic Range (min / max)	ch.4	dBm	---	-76/0
	ch.10	dBm	---	-76/0
	ch.41	dBm	---	-74/+4

< LCD PANEL >

Description	Condition	Unit	Nominal	Limit
1. Native Pixel Resolution	Horizontal	pixels	1366	---
	Vertical	pixels	768	---
2. Brightness	---	cd/m ²	320	---
3. Viewing Angle	Horizontal	°	-88 to +88	---
	Vertical	°	-88 to +88	---

< VIDEO >

Description	Condition	Unit	Nominal	Limit
1. Over Scan	Horizontal	%	5	5±5
	Vertical	%	5	5±5
2. Color Temperature	---	°K	12000	---
	x	---	0.272	±3%
	y	---	0.278	±3%
3. Resolution (composite video)	Horizontal	line	400	---
	Vertical	line	350	---

< AUDIO >

All items are measured across 8 Ω load at speaker output terminal with L.P.F.

Description	Condition	Unit	Nominal	Limit
1. Audio Output Max Power (ATSC 0dBfs)	Lch/Rch	W	10.0/10.0	9.0/9.0
2. Audio Distortion (NTSC)	500mW: Lch/Rch	%	0.5/0.5	2.0/2.0
3. Audio Freq. Response (NTSC)	-6dB: Lch -6dB: Rch	Hz Hz	70 to 10 k 70 to 10 k	--- ---

Note: Nominal specifications represent the design specifications. All units should be able to approximate these. Some will exceed and some may drop slightly below these specifications. Limit specifications represent the absolute worst condition that still might be considered acceptable. In no case should a unit fail to meet limit specifications.

IMPORTANT SAFETY PRECAUTIONS

Prior to shipment from the factory, our products are strictly inspected for recognized product safety and electrical codes of the countries in which they are to be sold. However, in order to maintain such compliance, it is equally important to implement the following precautions when a set is being serviced.

Safety Precautions for LCD TV Circuit

1. **Before returning an instrument to the customer**, always make a safety check of the entire instrument, including, but not limited to, the following items:

a. Be sure that no built-in protective devices are defective and have been defeated during servicing. (1) Protective shields are provided on this chassis to protect both the technician and the customer. Correctly replace all missing protective shields, including any removed for servicing convenience. (2) When reinstalling the chassis and/or other assembly in the cabinet, be sure to put back in place all protective devices, including but not limited to, nonmetallic control knobs, insulating fishpapers, adjustment and compartment covers/shields, and isolation resistor/capacitor networks. **Do not operate this instrument or permit it to be operated without all protective devices correctly installed and functioning. Servicers who defeat safety features or fail to perform safety checks may be liable for any resulting damage.**

b. Be sure that there are no cabinet openings through which an adult or child might be able to insert their fingers and contact a hazardous voltage. Such openings include, but are not limited to, (1) spacing between the Liquid Crystal Panel and the cabinet mask, (2) excessively wide cabinet ventilation slots, and (3) an improperly fitted and/or incorrectly secured cabinet back cover.

c. **Antenna Cold Check** - With the instrument AC plug removed from any AC source, connect an electrical jumper across the two AC plug prongs. Place the instrument AC switch in the on position. Connect one lead of an ohmmeter to the AC plug prongs tied together and touch the other ohmmeter lead in turn to each tuner antenna input exposed terminal screw and, if applicable, to the coaxial connector. If the measured resistance is less than 1.0 megohm or greater than 5.2 megohm, an abnormality exists that must be corrected before the instrument is returned to the customer. Repeat this test with the instrument AC switch in the off position.

d. **Leakage Current Hot Check** - With the instrument completely reassembled, plug the AC line cord directly into a 120 V AC outlet. (Do not use an isolation transformer during this test.) Use a leakage current tester or a metering system that complies with American National Standards Institute (ANSI) C101.1 Leakage Current for Appliances and Underwriters Laboratories (UL) 1410, (50.7). With the instrument AC switch first in the on position and then in the off position, measure from a known earth ground (metal water pipe, conduit, etc.) to all exposed metal parts of the instrument (antennas, handle brackets, metal cabinet, screw heads, metallic overlays, control shafts, etc.), especially any exposed metal parts that offer an electrical return path to the chassis. Any current measured must not exceed 0.5 milli-ampere. Reverse the instrument power cord plug in the outlet and repeat the test.

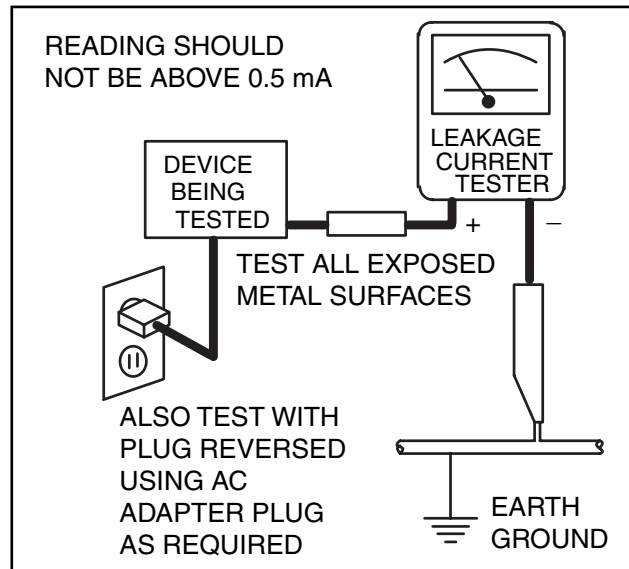

ANY MEASUREMENTS NOT WITHIN THE LIMITS SPECIFIED HEREIN INDICATE A POTENTIAL SHOCK HAZARD THAT MUST BE ELIMINATED BEFORE RETURNING THE INSTRUMENT TO THE CUSTOMER OR BEFORE CONNECTING THE ANTENNA OR ACCESSORIES.

2. Read and comply with all caution and safety-related notes on or inside the receiver cabinet, on the receiver chassis, or on the Liquid Crystal Panel.

3. **Design Alteration Warning** - Do not alter or add to the mechanical or electrical design of this TV receiver. Design alterations and additions, including, but not limited to circuit modifications and the addition of items such as auxiliary audio and/or video output connections, might alter the safety characteristics of this receiver and create a hazard to the user. Any design alterations or additions will void the manufacturer's warranty and may make you, the servicer, responsible for personal injury or property damage resulting therefrom.
4. **Hot Chassis Warning** -
 - a. Some TV receiver chassis are electrically connected directly to one conductor of the AC power cord and maybe safety-serviced without an isolation transformer only if the AC power plug is inserted so that the chassis is connected to the ground side of the AC power source. To confirm that the AC power plug is inserted correctly, with an AC voltmeter, measure between the chassis and a known earth ground. If a voltage reading in excess of 1.0 V is obtained, remove and reinsert the AC power plug in the opposite polarity and again measure the voltage potential between the chassis and a known earth ground.
 - b. Some TV receiver chassis normally have 85V AC(RMS) between chassis and earth ground regardless of the AC plug polarity. This chassis can be safety-serviced only with an isolation transformer inserted in the power line between the receiver and the AC power source, for both personnel and test equipment protection.
 - c. Some TV receiver chassis have a secondary ground system in addition to the main chassis ground. This secondary ground system is not isolated from the AC power line. The two ground systems are electrically separated by insulation material that must not be defeated or altered.
5. Observe original lead dress. Take extra care to assure correct lead dress in the following areas: a. near sharp edges, b. near thermally hot parts-be sure that leads and components do not touch thermally hot parts, c. the AC supply, d. high voltage, and, e. antenna wiring. Always inspect in all areas for pinched, out of place, or frayed wiring. Check AC power cord for damage.
6. Components, parts, and/or wiring that appear to have overheated or are otherwise damaged should be replaced with components, parts, or wiring that meet original specifications. Additionally, determine the cause of overheating and/or damage and, if necessary, take corrective action to remove any potential safety hazard.
7. **Product Safety Notice** - Some electrical and mechanical parts have special safety-related characteristics which are often not evident from visual inspection, nor can the protection they give necessarily be obtained by replacing them with components rated for higher voltage, wattage, etc. Parts that have special safety characteristics are identified by a  on schematics and in parts lists. Use of a substitute replacement that does not have the same safety characteristics as the recommended replacement part might create shock, fire, and/or other hazards. The product's safety is under review continuously and new instructions are issued whenever appropriate. Prior to shipment from the factory, our products are strictly inspected to confirm they comply with the recognized product safety and electrical codes of the countries in which they are to be sold. However, in order to maintain such compliance, it is equally important to implement the following precautions when a set is being serviced.

Precautions during Servicing

- A.** Parts identified by the **▲** symbol are critical for safety.
Replace only with part number specified.
- B.** In addition to safety, other parts and assemblies are specified for conformance with regulations applying to spurious radiation. These must also be replaced only with specified replacements.
Examples: RF converters, RF cables, noise blocking capacitors, and noise blocking filters, etc.
- C.** Use specified internal wiring. Note especially:
 - 1) Wires covered with PVC tubing
 - 2) Double insulated wires
 - 3) High voltage leads
- D.** Use specified insulating materials for hazardous live parts. Note especially:
 - 1) Insulation Tape
 - 2) PVC tubing
 - 3) Spacers
 - 4) Insulators for transistors.
- E.** When replacing AC primary side components (transformers, power cord, etc.), wrap ends of wires securely about the terminals before soldering.
- F.** Observe that the wires do not contact heat producing parts (heat sinks, oxide metal film resistors, fusible resistors, etc.)
- G.** Check that replaced wires do not contact sharp edged or pointed parts.
- H.** When a power cord has been replaced, check that 5~6 kg of force in any direction will not loosen it.
- I.** Also check areas surrounding repaired locations.
- J.** Use care that foreign objects (screws, solder droplets, etc.) do not remain inside the set.
- K.** When connecting or disconnecting the internal connectors, first, disconnect the AC plug from the AC supply outlet.
- L.** When installing parts or assembling the cabinet parts, be sure to use the proper screws and tighten certainly.

Safety Check after Servicing

Examine the area surrounding the repaired location for damage or deterioration. Observe that screws, parts and wires have been returned to original positions. Afterwards, perform the following tests and confirm the specified values in order to verify compliance with safety standards.

1. Clearance Distance

When replacing primary circuit components, confirm specified clearance distance (d) and (d') between soldered terminals, and between terminals and surrounding metallic parts. (See Fig. 1)

Table 1: Ratings for selected area

AC Line Voltage	Region	Clearance Distance (d), (d')
110 to 130 V	U.S.A. or Canada	≥ 3.2 mm (0.126 inches)

Note: This table is unofficial and for reference only. Be sure to confirm the precise values.

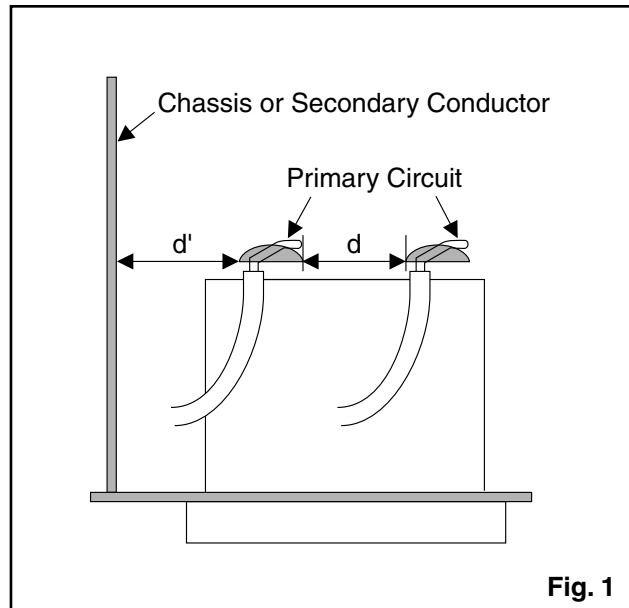

Fig. 1

2. Leakage Current Test

Confirm the specified (or lower) leakage current between B (earth ground, power cord plug prongs) and externally exposed accessible parts (RF terminals, antenna terminals, video and audio input and output terminals, microphone jacks, earphone jacks, etc.) is lower than or equal to the specified value in the table below.

Measuring Method: (Power ON)

Insert load Z between B (earth ground, power cord plug prongs) and exposed accessible parts. Use an AC voltmeter to measure across both terminals of load Z. See Fig. 2 and following table.

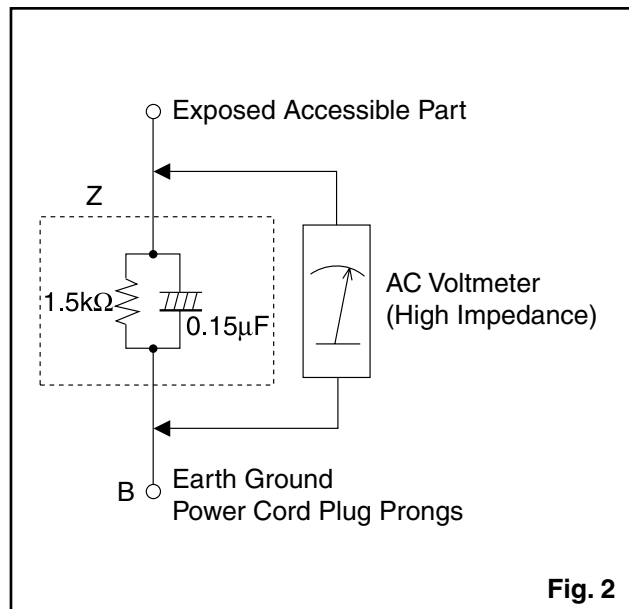

Fig. 2

Table 2: Leakage current ratings for selected areas

AC Line Voltage	Region	Load Z	Leakage Current (i)	Earth Ground (B) to:
110 to 130 V	U.S.A. or Canada	$0.15\mu\text{F}$ CAP. & $1.5\text{k}\Omega$ RES. Connected in parallel	$i \leq 0.5$ mA rms	Exposed accessible parts

Note: This table is unofficial and for reference only. Be sure to confirm the precise values.

STANDARD NOTES FOR SERVICING

Circuit Board Indications

1. The output pin of the 3 pin Regulator ICs is indicated as shown.

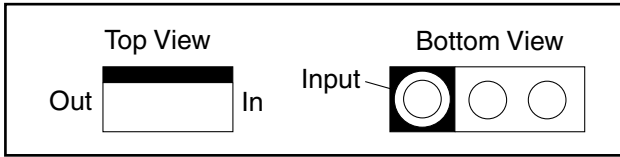

2. For other ICs, pin 1 and every fifth pin are indicated as shown.

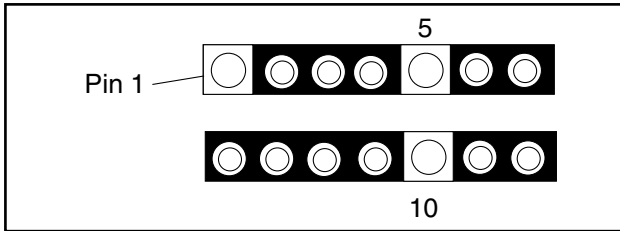

3. The 1st pin of every male connector is indicated as shown.

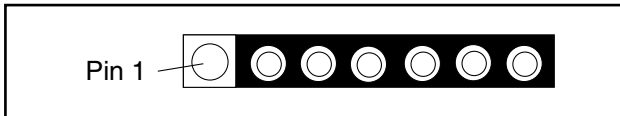

Pb (Lead) Free Solder

Pb free mark will be found on PCBs which use Pb free solder. (Refer to figure.) For PCBs with Pb free mark, be sure to use Pb free solder. For PCBs without Pb free mark, use standard solder.

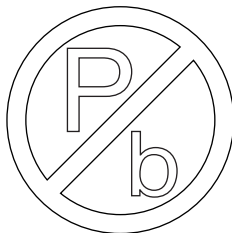

Pb free mark

How to Remove / Install Flat Pack-IC

1. Removal

With Hot-Air Flat Pack-IC Desoldering Machine:

1. Prepare the hot-air flat pack-IC desoldering machine, then apply hot air to the Flat Pack-IC (about 5 to 6 seconds). (Fig. S-1-1)

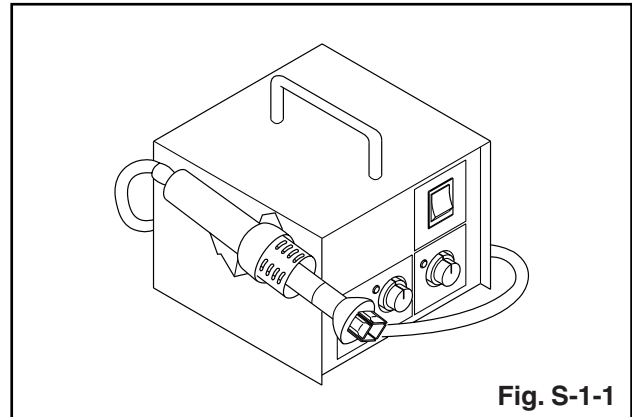

Fig. S-1-1

2. Remove the flat pack-IC with tweezers while applying the hot air.
3. Bottom of the flat pack-IC is fixed with glue to the CBA; when removing entire flat pack-IC, first apply soldering iron to center of the flat pack-IC and heat up. Then remove (glue will be melted). (Fig. S-1-6)
4. Release the flat pack-IC from the CBA using tweezers. (Fig. S-1-6)

CAUTION:

1. The Flat Pack-IC shape may differ by models. Use an appropriate hot-air flat pack-IC desoldering machine, whose shape matches that of the Flat Pack-IC.
2. Do not supply hot air to the chip parts around the flat pack-IC for over 6 seconds because damage to the chip parts may occur. Put masking tape around the flat pack-IC to protect other parts from damage. (Fig. S-1-2)

3. The flat pack-IC on the CBA is affixed with glue, so be careful not to break or damage the foil of each pin or the solder lands under the IC when removing it.

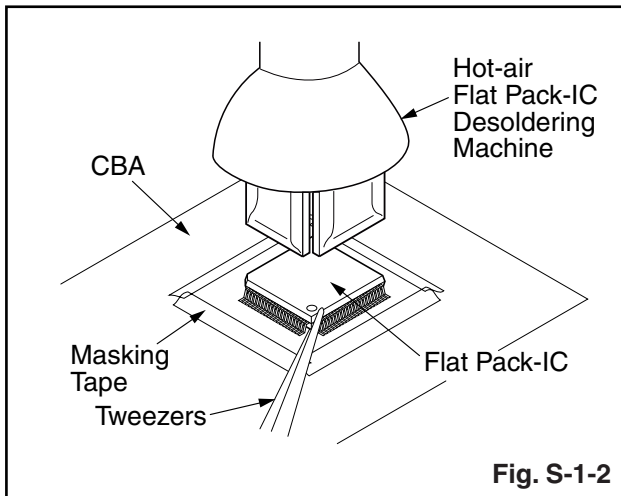

With Soldering Iron:

1. Using desoldering braid, remove the solder from all pins of the flat pack-IC. When you use solder flux which is applied to all pins of the flat pack-IC, you can remove it easily. (Fig. S-1-3)

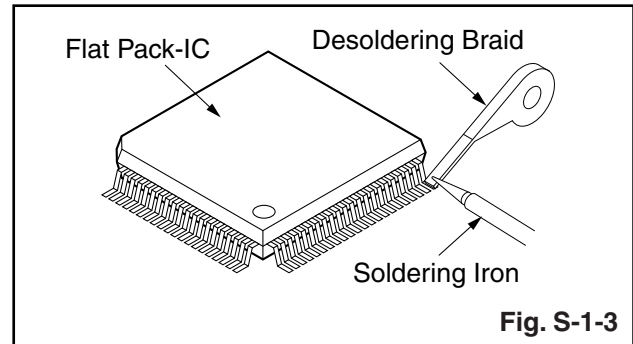

2. Lift each lead of the flat pack-IC upward one by one, using a sharp pin or wire to which solder will not adhere (iron wire). When heating the pins, use a fine tip soldering iron or a hot air desoldering machine. (Fig. S-1-4)

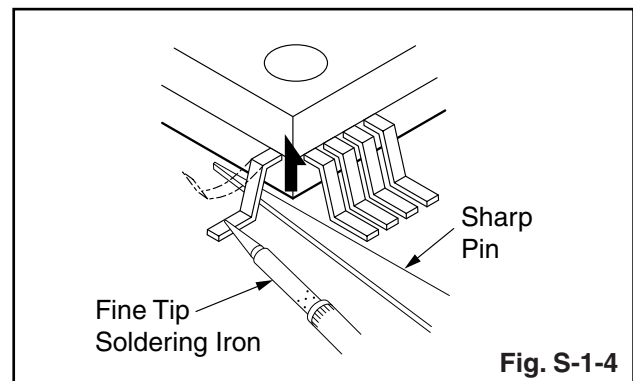

3. Bottom of the flat pack-IC is fixed with glue to the CBA; when removing entire flat pack-IC, first apply soldering iron to center of the flat pack-IC and heat up. Then remove (glue will be melted). (Fig. S-1-6)
4. Release the flat pack-IC from the CBA using tweezers. (Fig. S-1-6)

With Iron Wire:

1. Using desoldering braid, remove the solder from all pins of the flat pack-IC. When you use solder flux which is applied to all pins of the flat pack-IC, you can remove it easily. (Fig. S-1-3)
2. Affix the wire to a workbench or solid mounting point, as shown in Fig. S-1-5.
3. While heating the pins using a fine tip soldering iron or hot air blower, pull up the wire as the solder melts so as to lift the IC leads from the CBA contact pads as shown in Fig. S-1-5.
4. Bottom of the flat pack-IC is fixed with glue to the CBA; when removing entire flat pack-IC, first apply soldering iron to center of the flat pack-IC and heat up. Then remove (glue will be melted). (Fig. S-1-6)
5. Release the flat pack-IC from the CBA using tweezers. (Fig. S-1-6)

Note: When using a soldering iron, care must be taken to ensure that the flat pack-IC is not being held by glue. When the flat pack-IC is removed from the CBA, handle it gently because it may be damaged if force is applied.

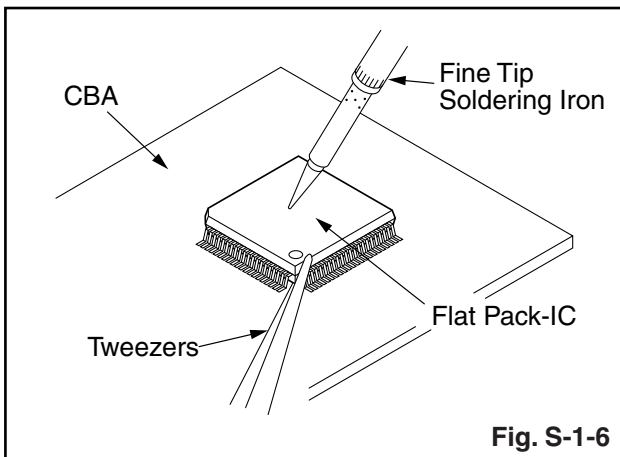
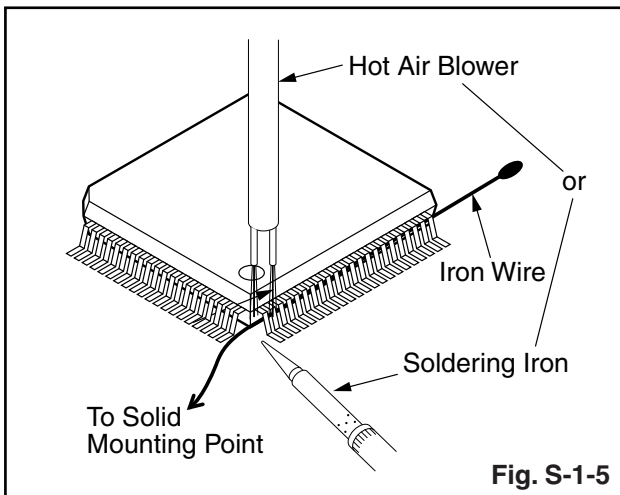

2. Installation

1. Using desoldering braid, remove the solder from the foil of each pin of the flat pack-IC on the CBA so you can install a replacement flat pack-IC more easily.
2. The "●" mark on the flat pack-IC indicates pin 1. (See Fig. S-1-7.) Be sure this mark matches the 1 on the PCB when positioning for installation. Then presolder the four corners of the flat pack-IC. (See Fig. S-1-8.)
3. Solder all pins of the flat pack-IC. Be sure that none of the pins have solder bridges.

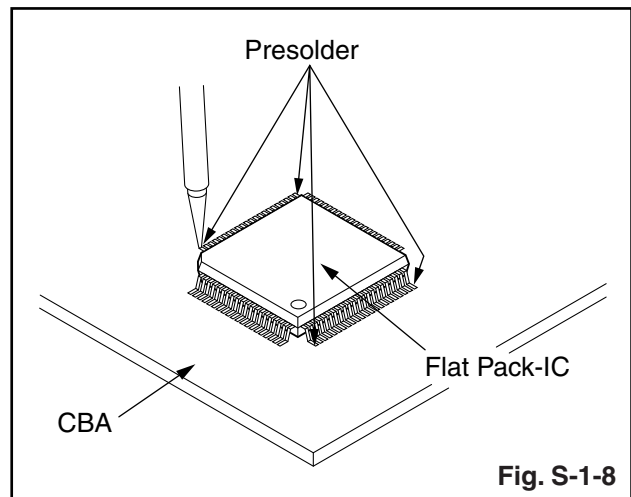
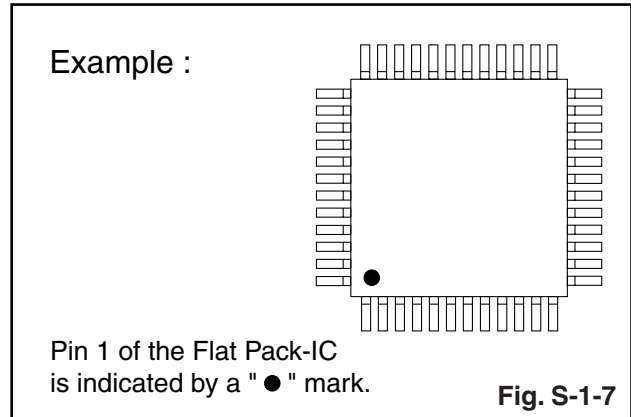

Instructions for Handling Semi-conductors

Electrostatic breakdown of the semi-conductors may occur due to a potential difference caused by electrostatic charge during unpacking or repair work.

1. Ground for Human Body

Be sure to wear a grounding band (1 MΩ) that is properly grounded to remove any static electricity that may be charged on the body.

2. Ground for Workbench

Be sure to place a conductive sheet or copper plate with proper grounding (1 MΩ) on the workbench or other surface, where the semi-conductors are to be placed. Because the static electricity charge on clothing will not escape through the body grounding band, be careful to avoid contacting semi-conductors with your clothing.

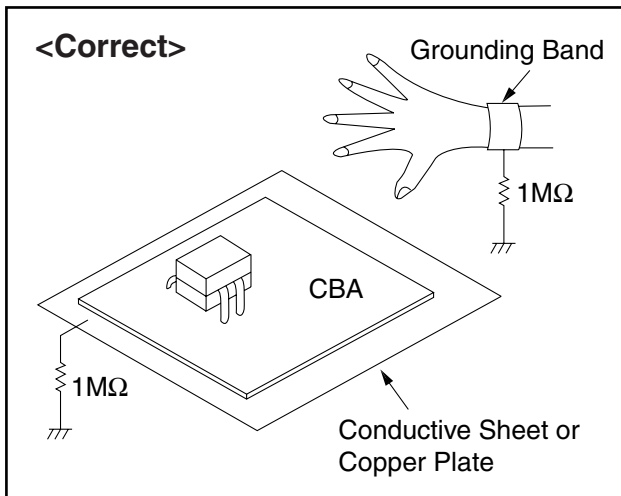
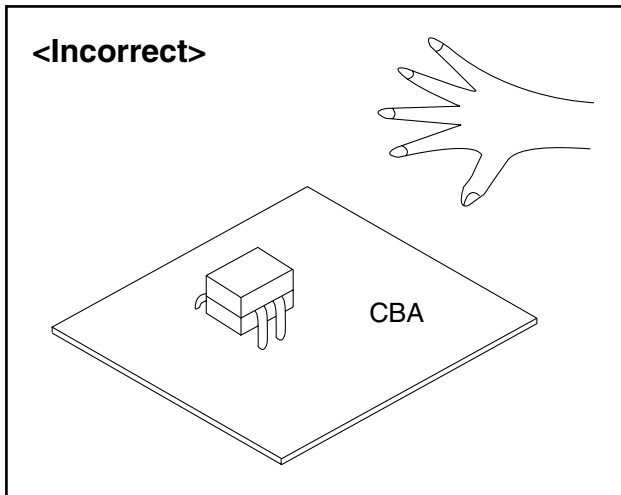

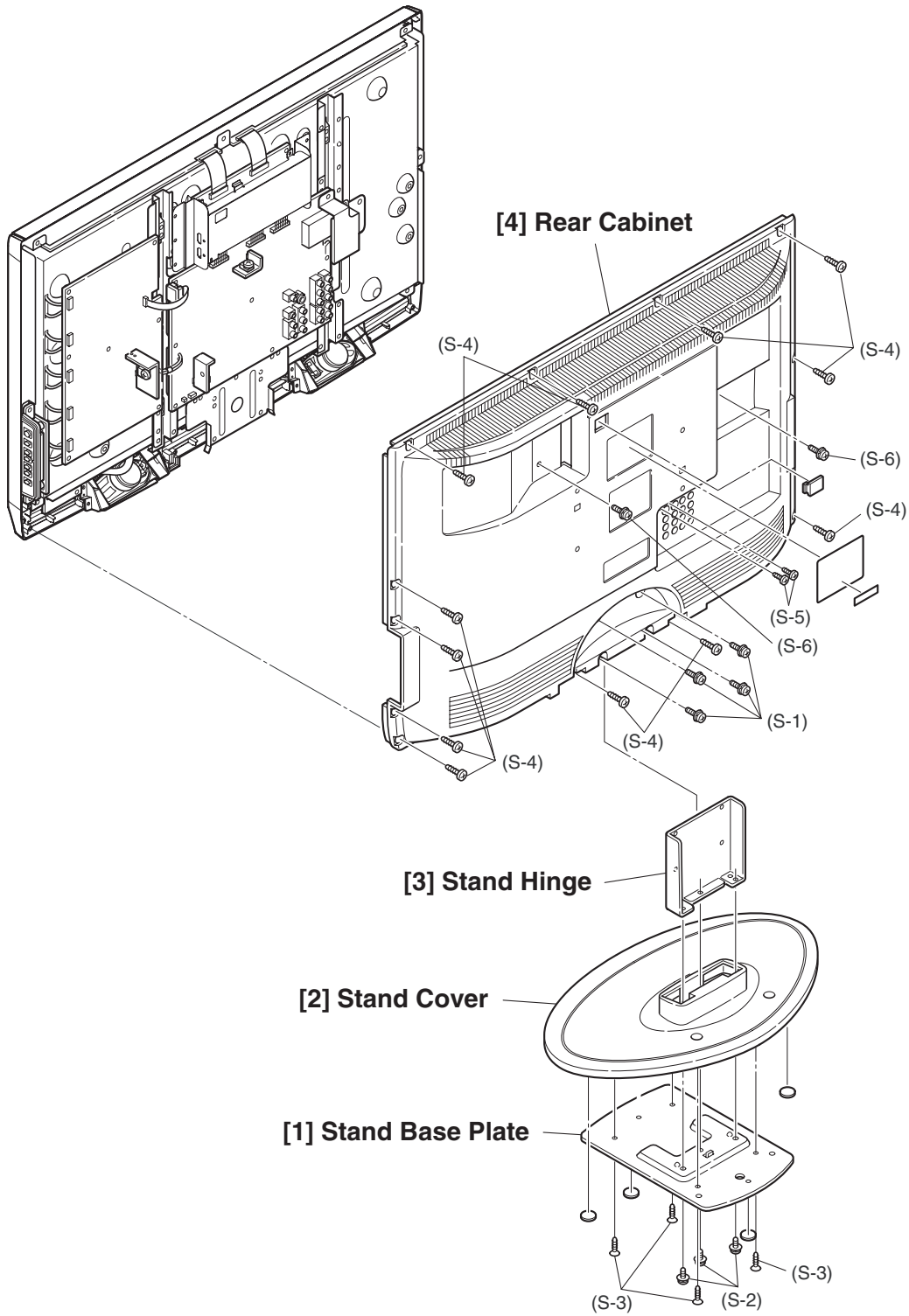
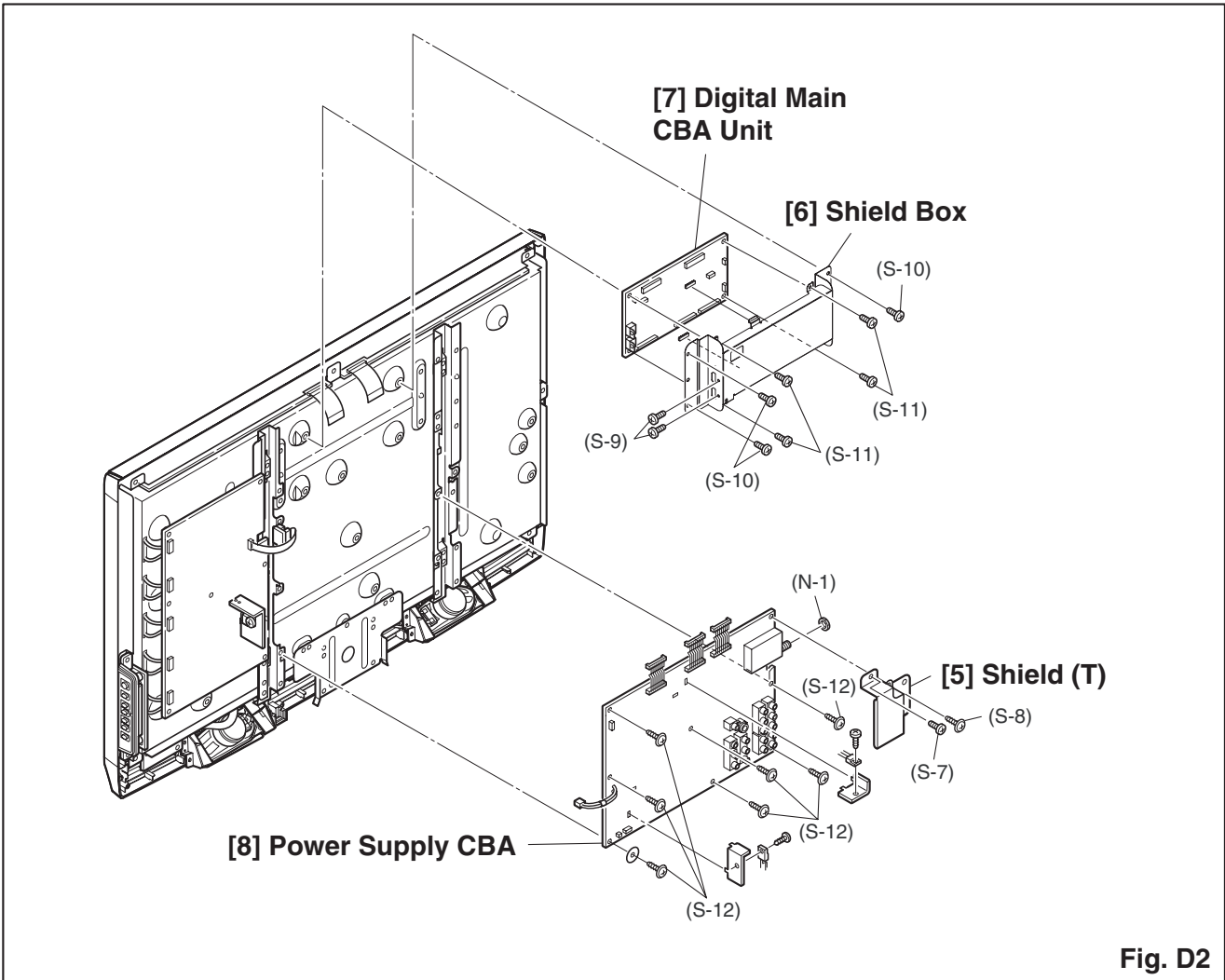
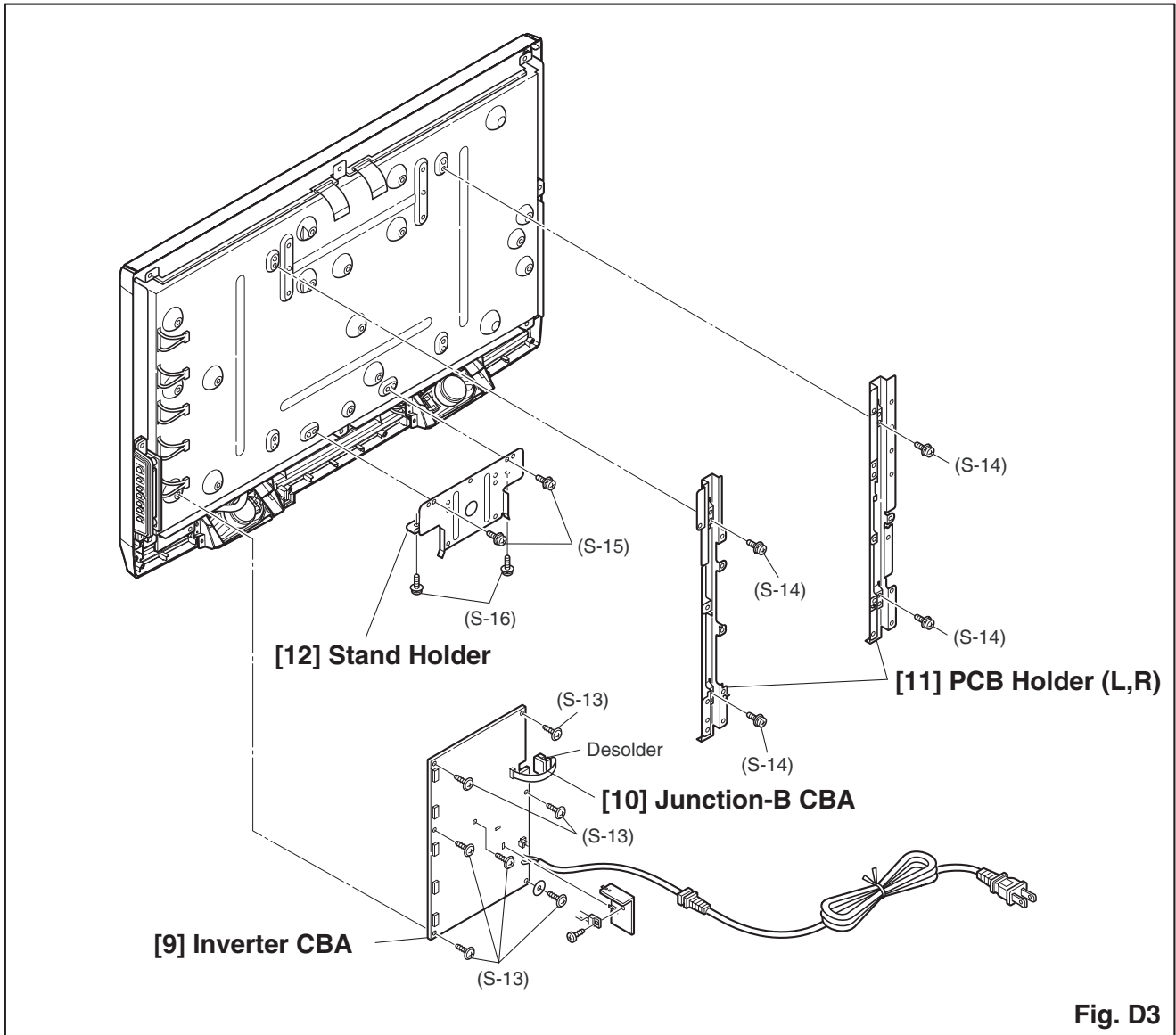

Fig. D1





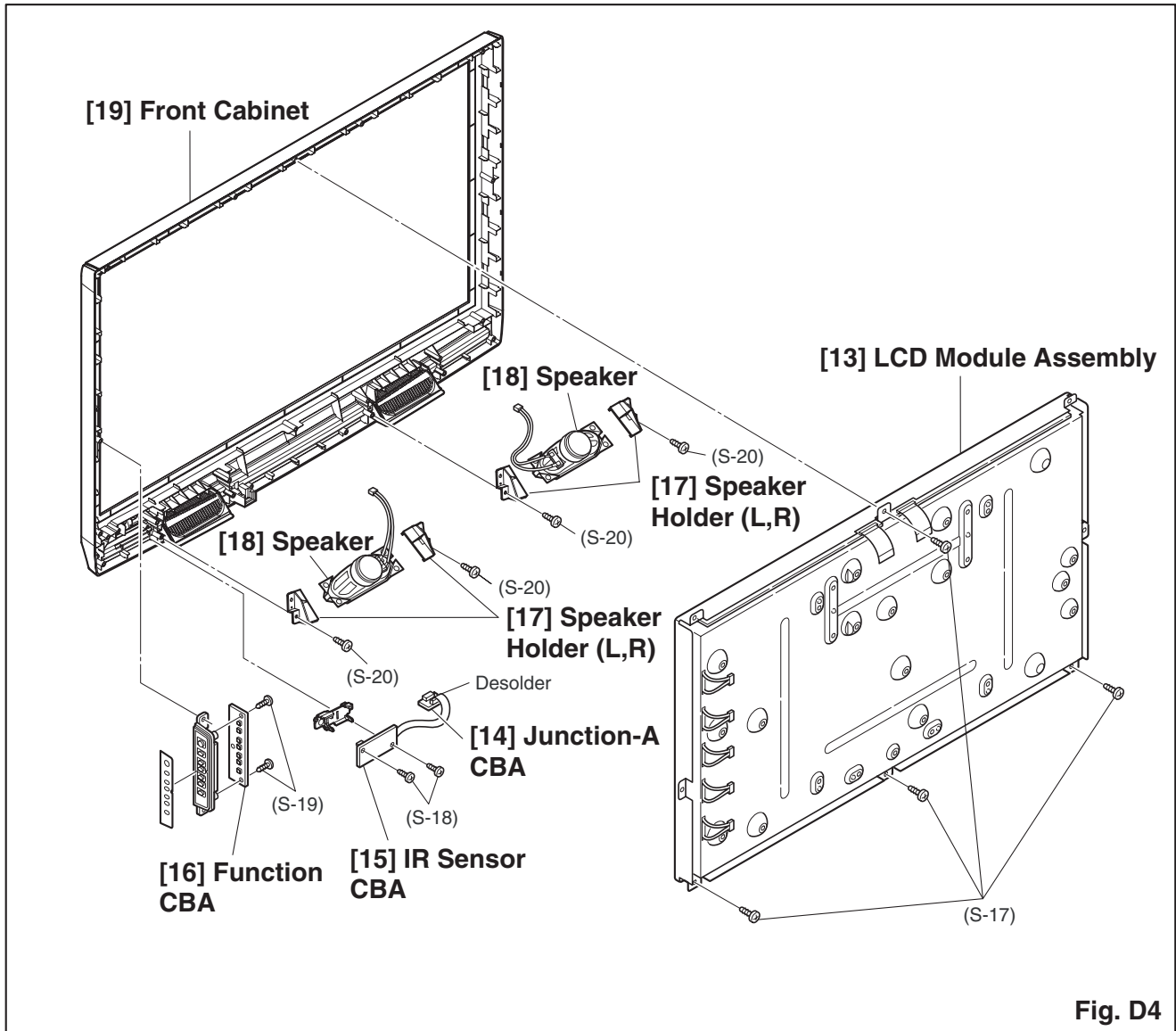

Fig. D4

TV Cable Wiring Diagram

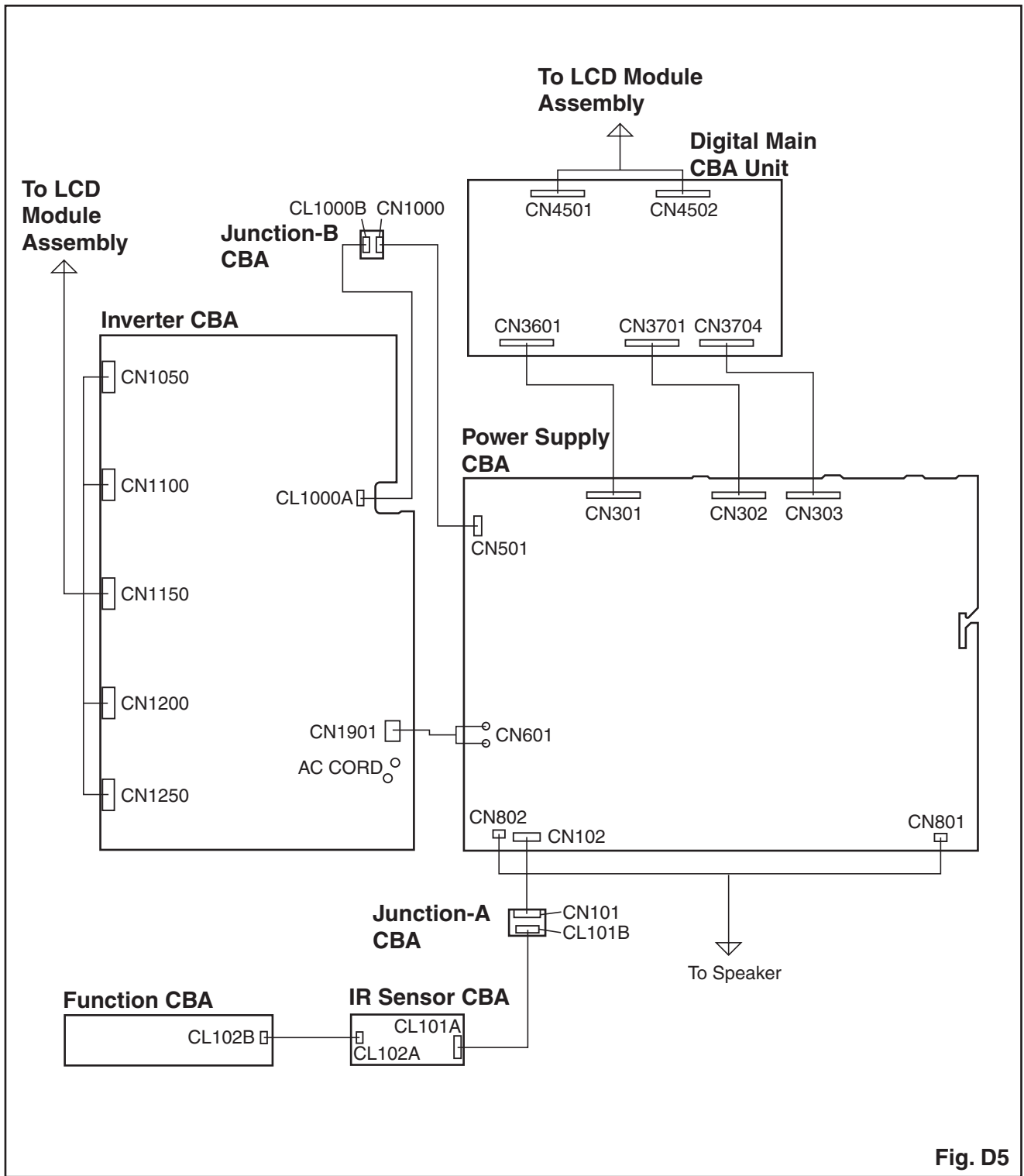

Fig. D5

ELECTRICAL ADJUSTMENT INSTRUCTIONS

General Note: “CBA” is abbreviation for “Circuit Board Assembly.”

Note: Electrical adjustments are required after replacing circuit components and certain mechanical parts. It is important to perform these adjustments only after all repairs and replacements have been completed. Also, do not attempt these adjustments unless the proper equipment is available.

Test Equipment Required

1. DC Voltmeter
2. NTSC Pattern Generator (Color Bar W/White Window, Red Color, Dot Pattern, Gray Scale, Monoscope, Multi-Burst)
3. Remote control unit
4. Color Analyzer

How to make the Service remote control unit:

Cut “A” portion of the attached remote control unit as shown in Fig. 1.

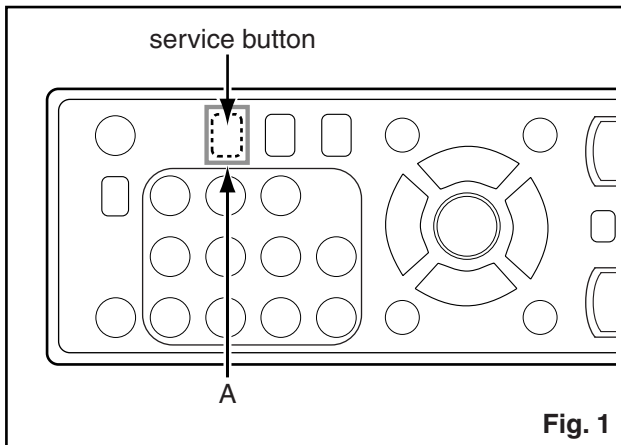

Fig. 1

How to set up the service mode:

Service mode:

1. Use the service remote control unit.
2. Turn the power on.
3. Press the service button on the service remote control unit. The following screen appears.

"*" differs depending on the models.

```
Code : *****_***
Boot : Push 0 key
System : Push 0 key
SubCPU : ****
Pic Code : **_***_**_****_***
Picture : ****

Panel : ***
Other : **
Safety : *****_***
Tuner : *****_*****
HDMI1 Block0 : **
          Block1 : **
HDMI2 Block1 : **
```

1. Purity Check Mode

This mode cycles through full-screen displays of red, green, blue, and white to check for non-active pixels.

1. Enter the Service mode.
2. Each time pressing [7] button on the service remote control unit, the display changes as follows.

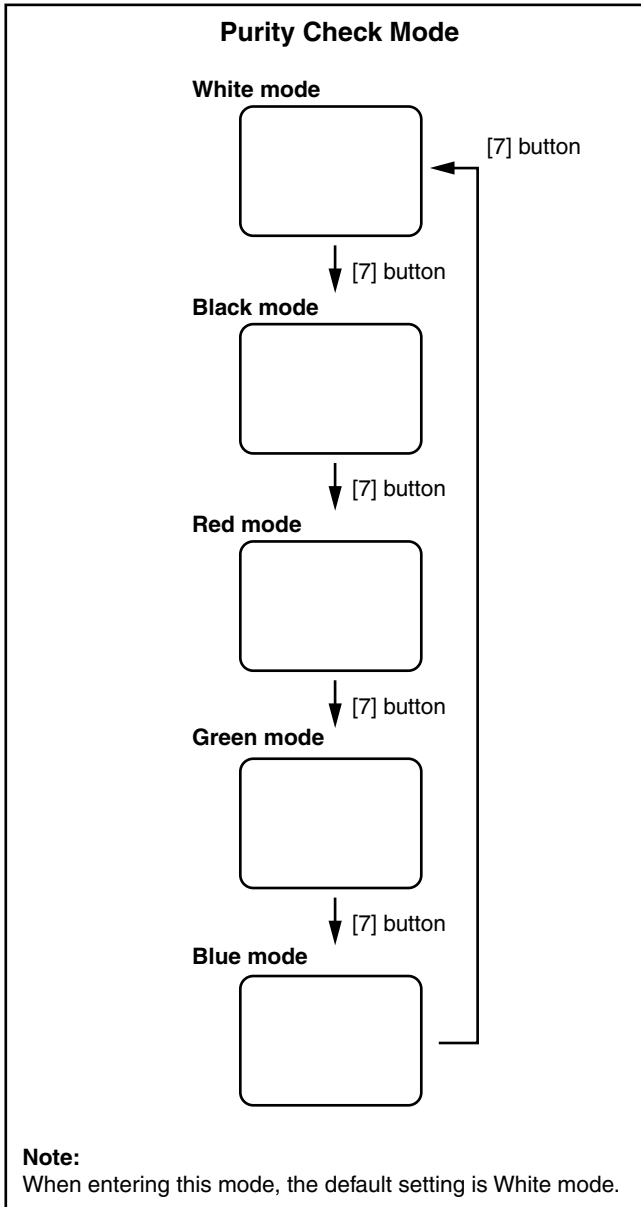

2. VCOM Adjustment.

Test Point	Adj. Point
Screen	[CH ▲/▼] buttons
M. EQ.	Spec.
Color analyzer	See below

Figure

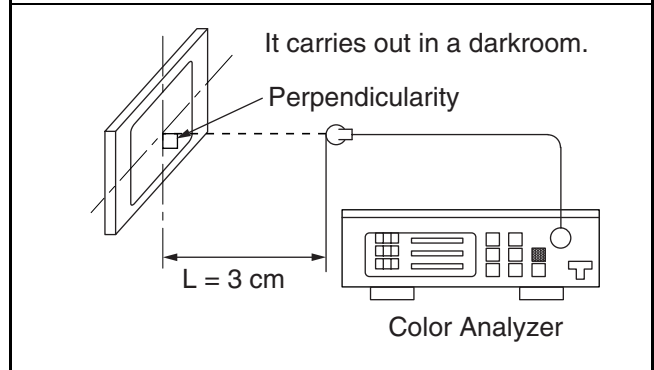

1. Operate the unit for more than 20 minutes.
2. Set the color analyzer and bring the optical receptor to the center on the LCD-Panel surface after zero point calibration as shown above.
Note: The optical receptor must be set perpendicularly to the LCD Panel surface.
3. Enter the Service mode.
4. Press [2] button on the service remote control unit.
5. Press [CH ▲ / ▼] buttons on the service remote control unit so that the color analyzer value becomes minimum.

The following adjustment normally are not attempted in the field. Only when replacing the LCD Panel then adjust as a preparation.

3. White Balance Adjustment

Purpose: To mix red, green and blue beams correctly for pure white.

Symptom of Misadjustment: White becomes bluish or reddish.

Test Point	Adj. Point	Mode	Input
Screen	[CH ▲/▼] buttons	[VIDEO1] C/D	White Raster (APL 70%) or (APL 25%)
M. EQ.		Spec.	
Pattern Generator, Color analyzer		$x = 0.272 \pm 0.005$ $y = 0.278 \pm 0.005$	

Figure

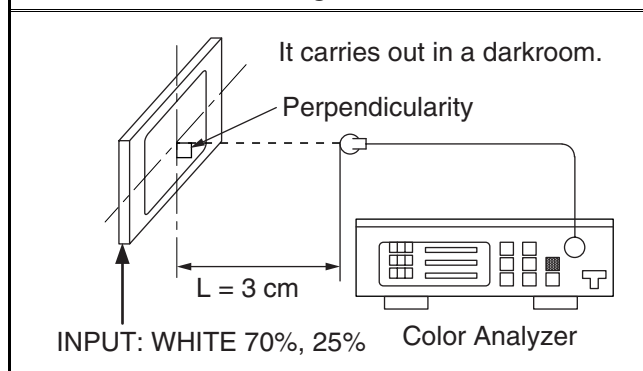

1. Operate the unit for more than 20 minutes.
2. Input the White Raster(70%=70IRE, 25%=25IRE).

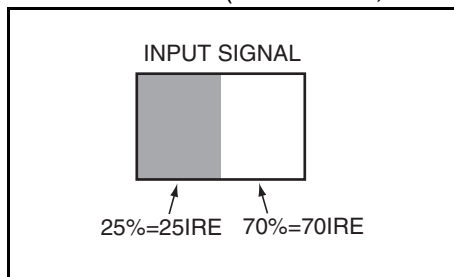

3. Set the color analyzer to the CHROMA mode and bring the optical receptor to the center on the LCD-Panel surface after zero point calibration as shown above.

Note: The optical receptor must be set perpendicularly to the LCD Panel surface.

4. Enter the Service mode. Press [VOL. ▼] button on the service remote control unit and select "C/D" mode.

5. **[CUTOFF]**
Press [3] button to select "COB" for Blue Cutoff adjustment. Press [1] button to select "COR" for Red Cutoff adjustment.

[DRIVE]

Press [6] button to select "DB" for Blue Drive adjustment. Press [4] button to select "DR" for Red Drive adjustment.

6. In each color mode, press [CH ▲ / ▼] buttons to adjust the values of color.
7. Adjust Cutoff and Drive so that the color temperature becomes 12000°K ($x = 0.272 / y = 0.278 \pm 0.005$).

HOW TO INITIALIZE THE LCD TELEVISION

How to initialize the LCD television:

1. Turn the power on.
2. To enter the service mode, press the service button on the service remote control unit. (Refer to page 5-1.)
 - To cancel the service mode, press [POWER] button on the remote control unit.
3. Press [INFO] button on the service remote control unit to initialize the LCD television.
4. "INITIALIZED" will appear in the upper right of the screen. "INITIALIZED" color will change to green from red when initializing is complete.

BLOCK DIAGRAMS

System Control Block Diagram

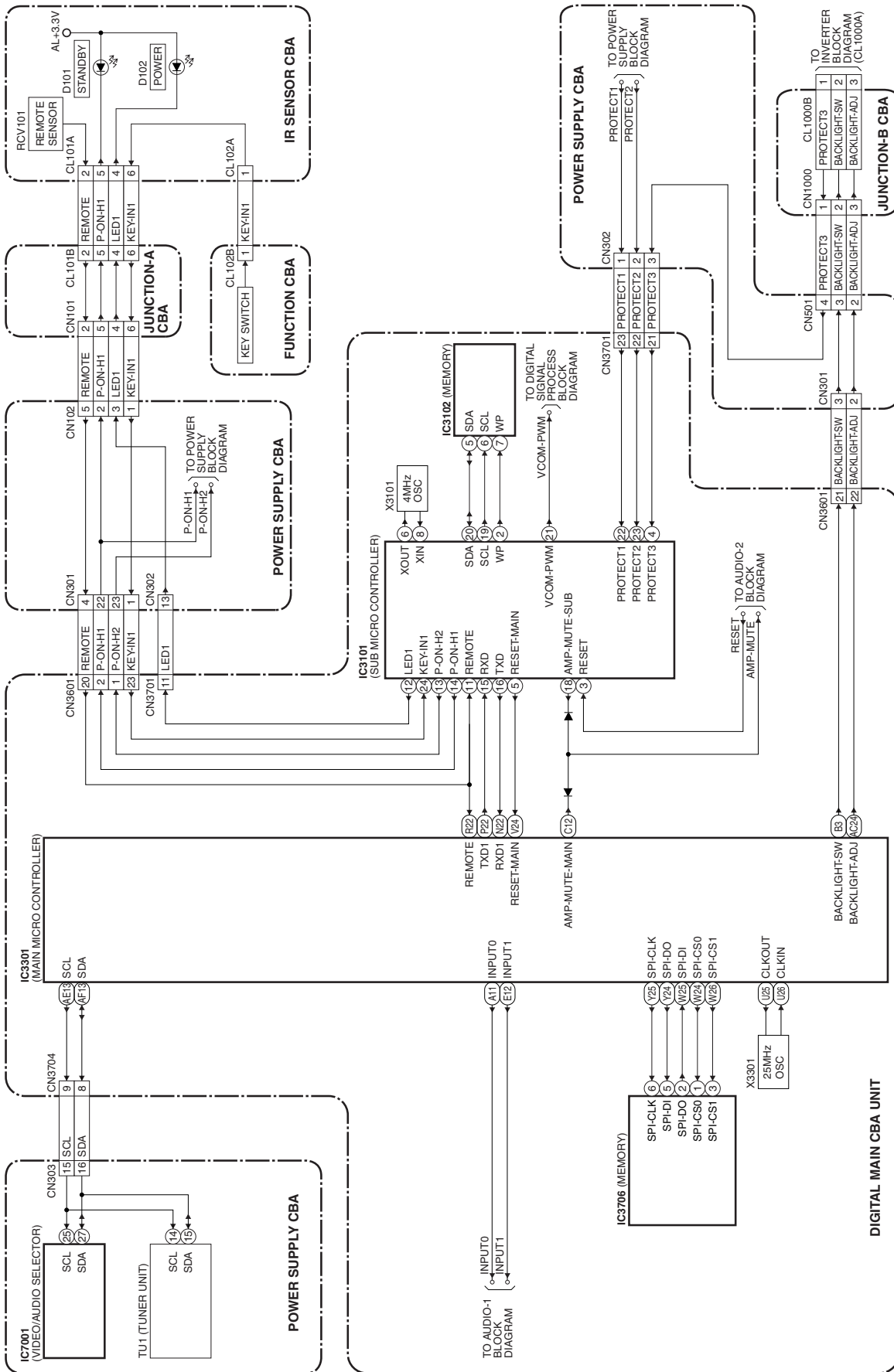

Video Block Diagram

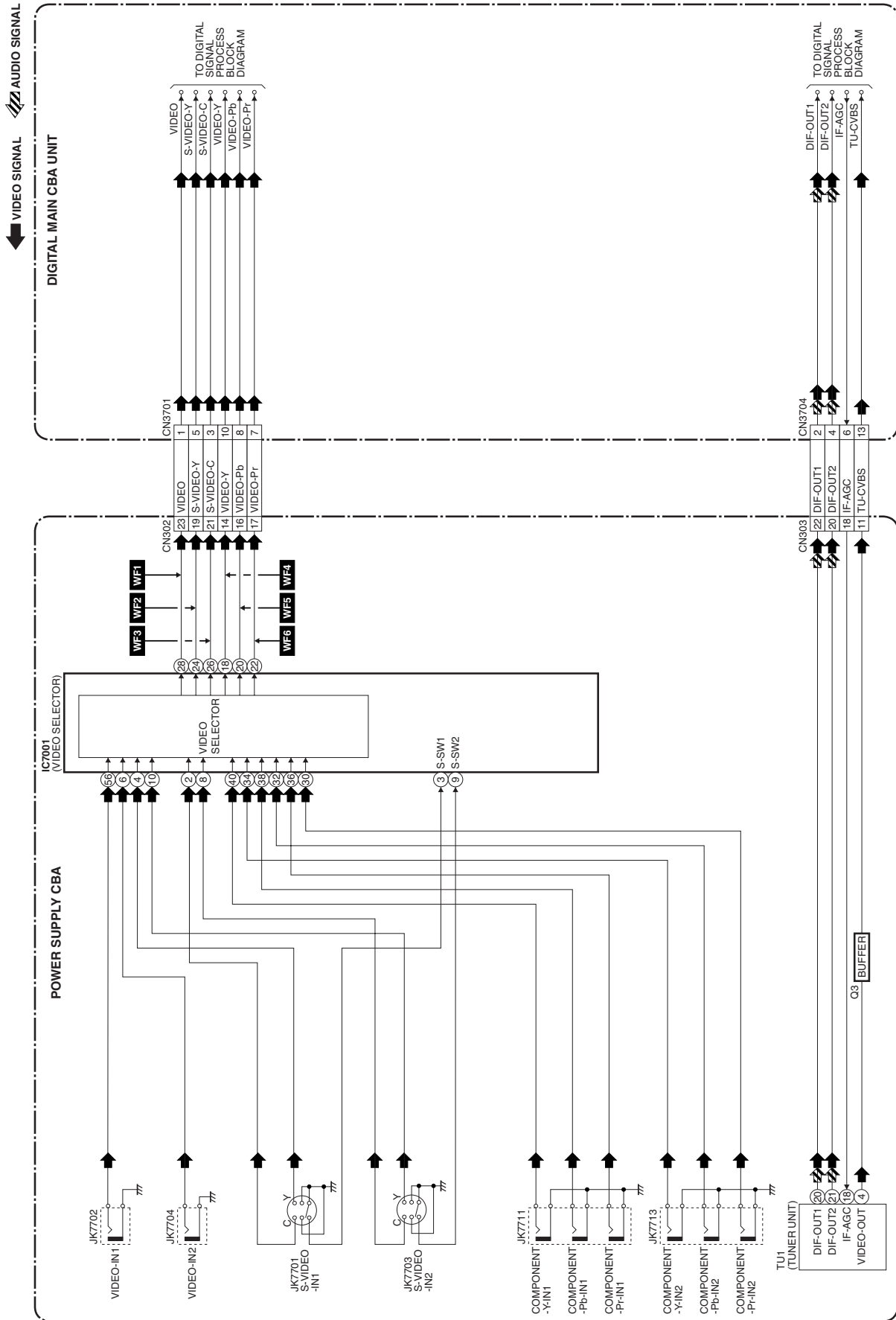

Audio-1 Block Diagram

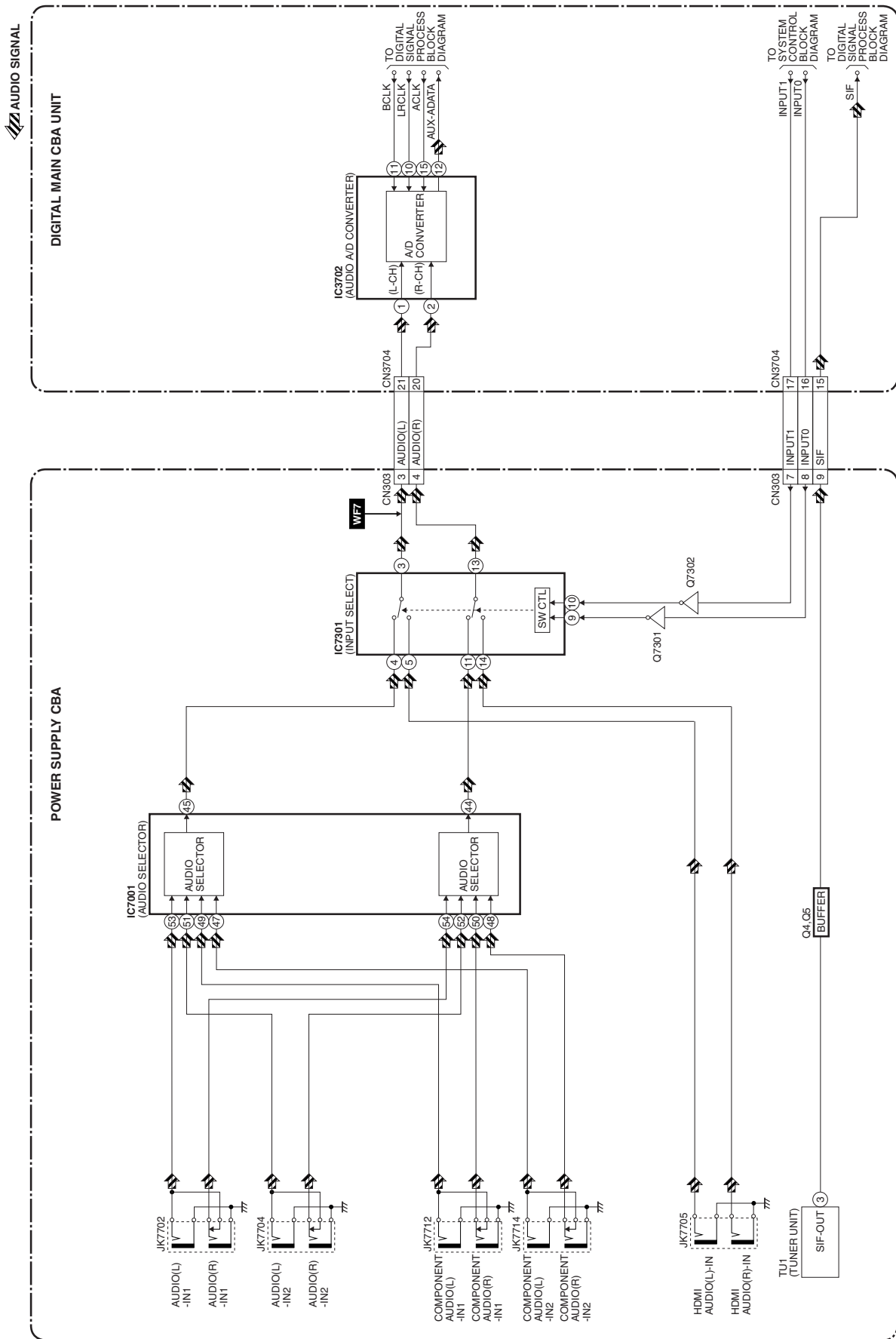

Audio-2 Block Diagram

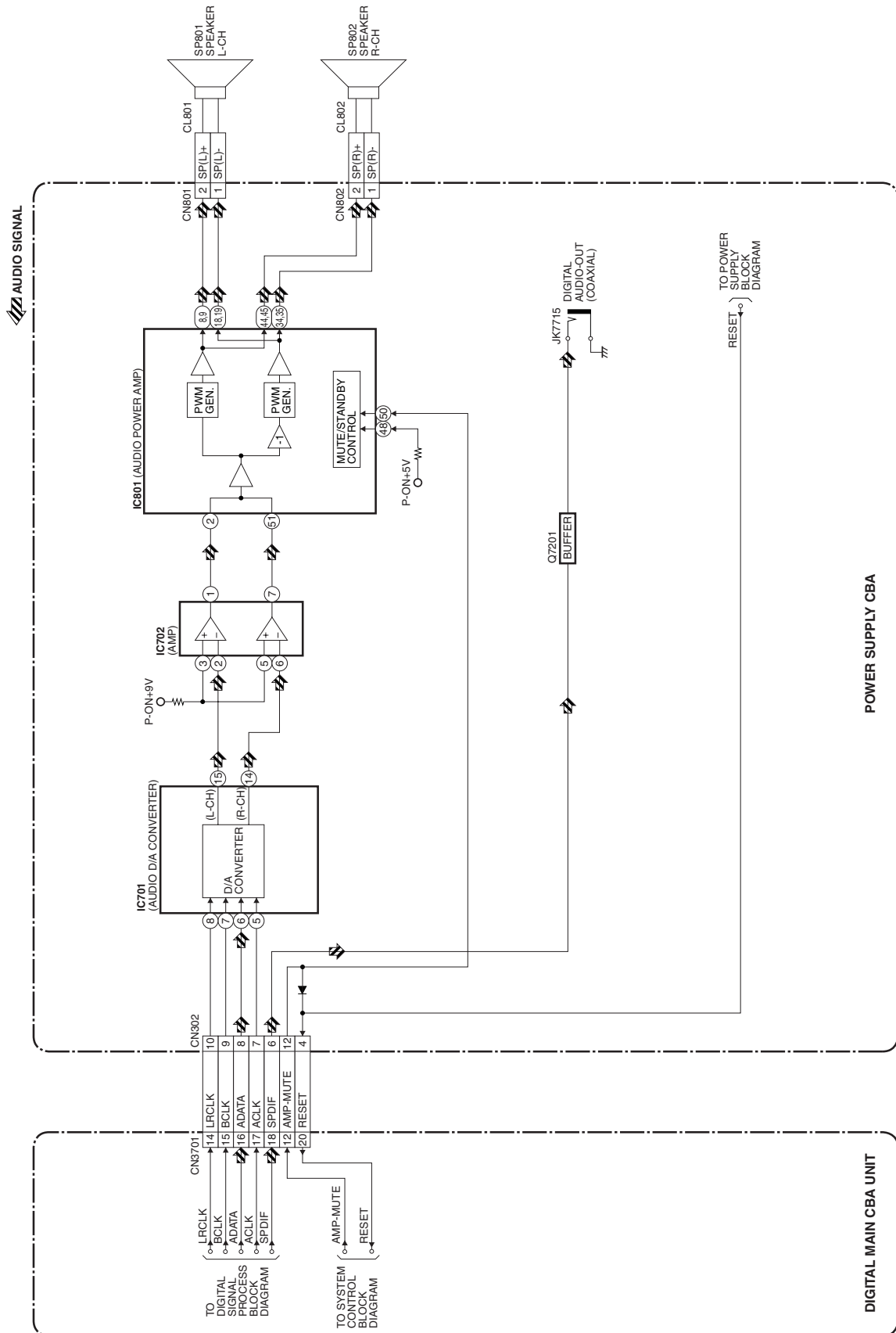

Digital Signal Process Block Diagram

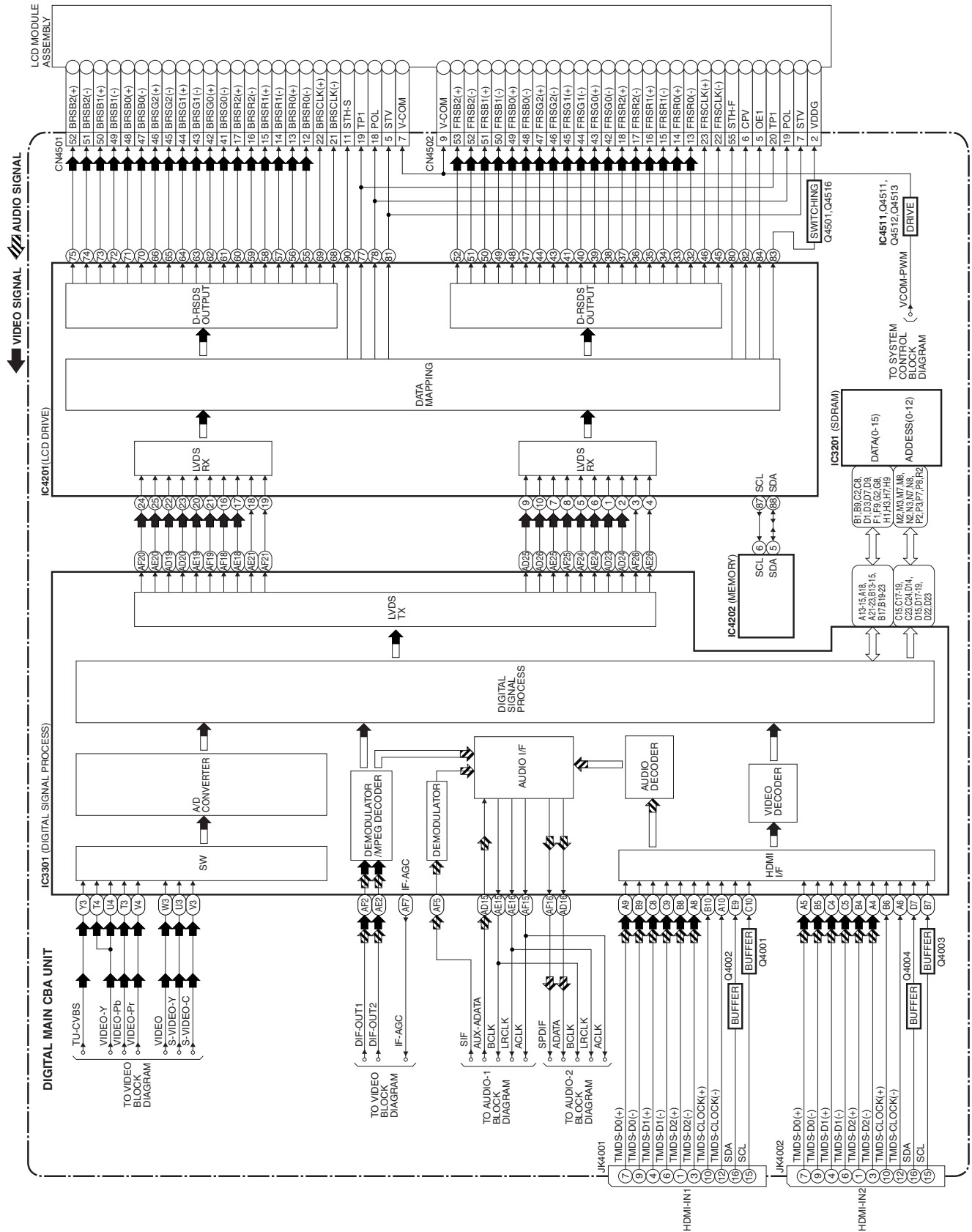

Inverter Block Diagram

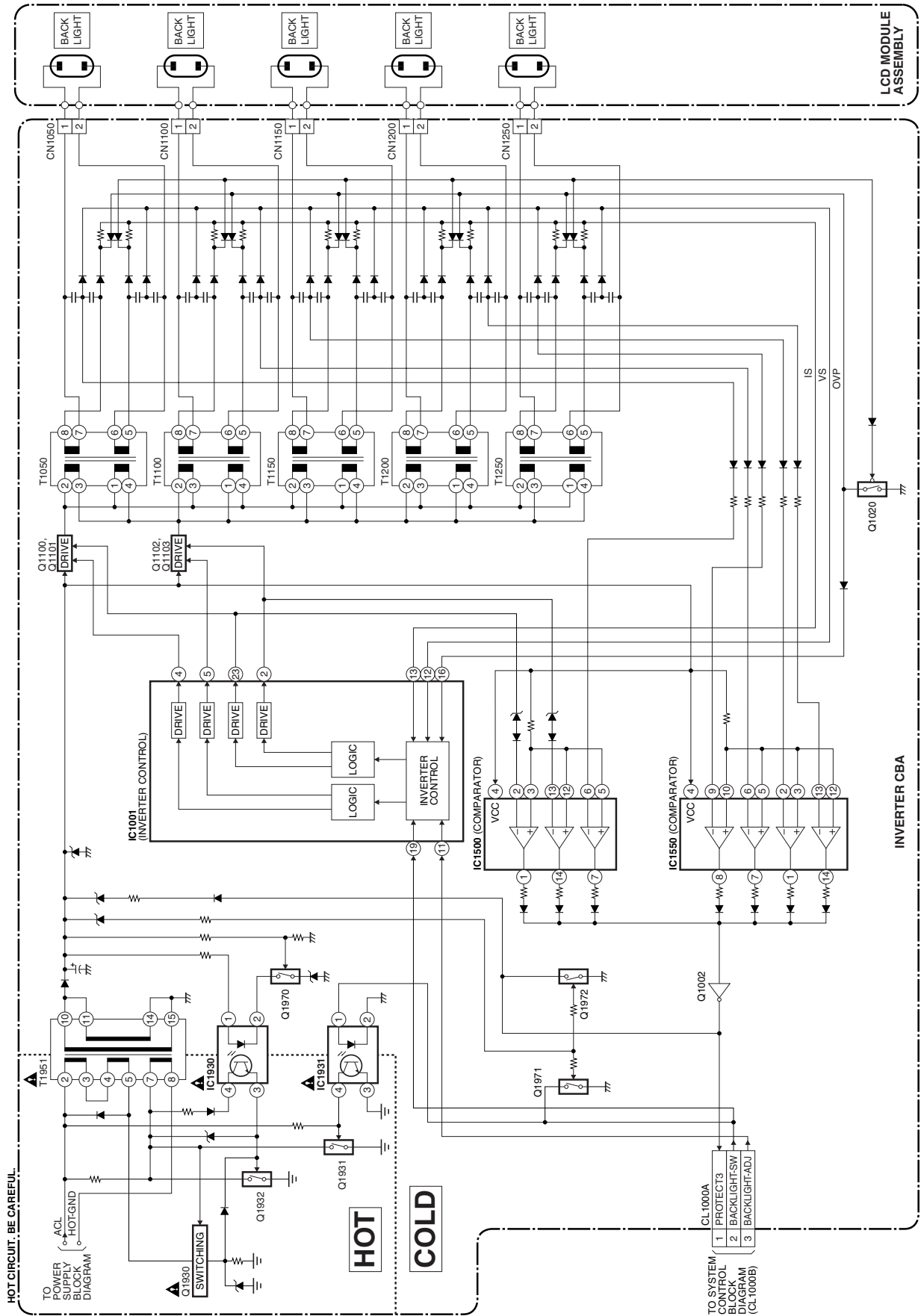

Power Supply Block Diagram

CAUTION !

Fixed voltage (or Auto voltage selectable) power supply circuit is used in this unit.
If Main Fuse (F1901) is blown, check to see that all components in the power supply circuit are not defective before you connect the AC plug to the AC power supply.
Otherwise it may cause some components in the power supply circuit to fail.

CAUTION ! :

For continued protection against risk of fire,
replace only with same type 4 A, 125V fuse.

ATTENTION :

The voltage for parts in hot circuit is measured using
hot GND as a common terminal.

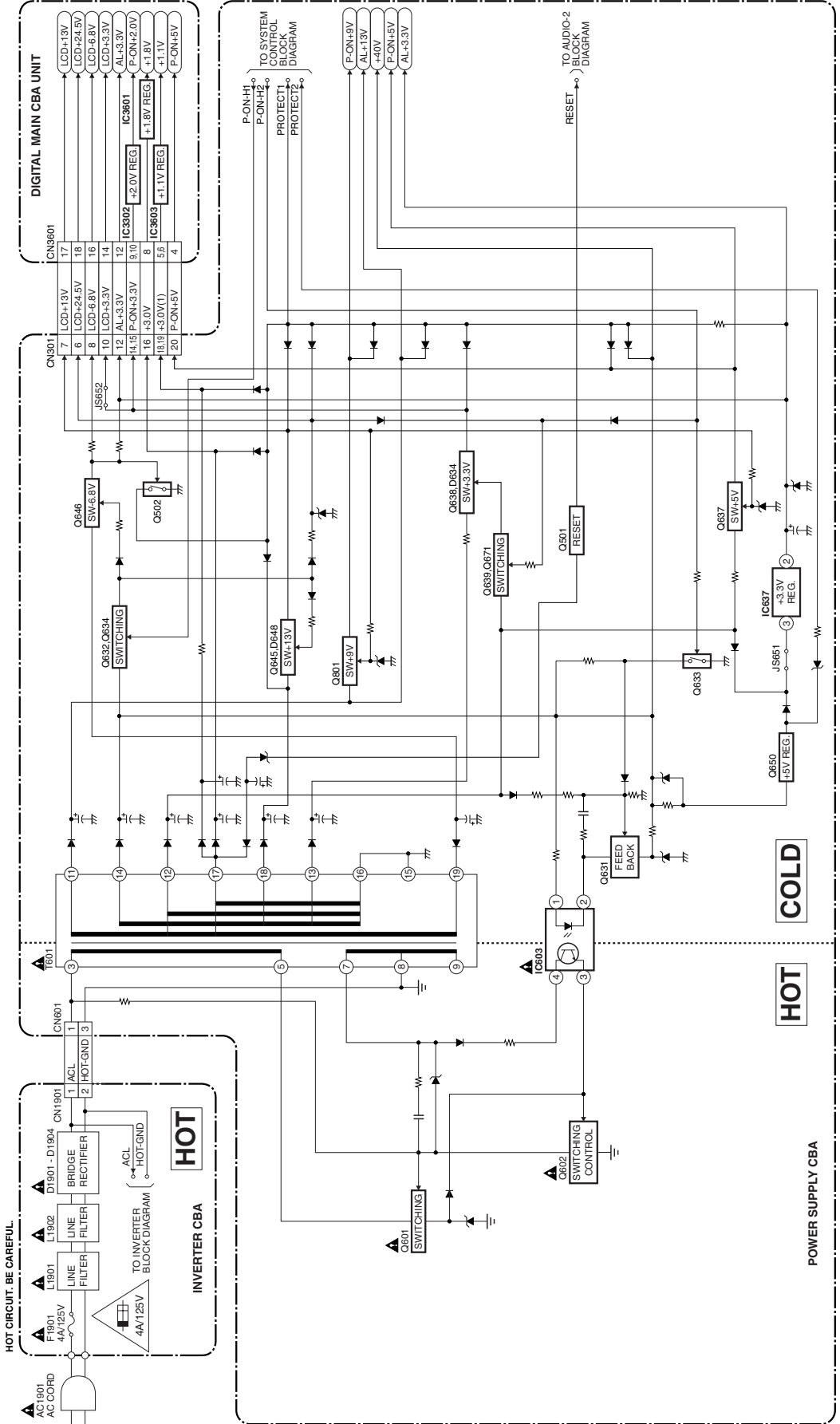

SCHEMATIC DIAGRAMS / CBA'S AND TEST POINTS

Standard Notes

WARNING

Many electrical and mechanical parts in this chassis have special characteristics. These characteristics often pass unnoticed and the protection afforded by them cannot necessarily be obtained by using replacement components rated for higher voltage, wattage, etc. Replacement parts that have these special safety characteristics are identified in this manual and its supplements; electrical components having such features are identified by the mark "▲" in the schematic diagram and the parts list. Before replacing any of these components, read the parts list in this manual carefully. The use of substitute replacement parts that do not have the same safety characteristics as specified in the parts list may create shock, fire, or other hazards.

Notes:

1. Do not use the part number shown on these drawings for ordering. The correct part number is shown in the parts list, and may be slightly different or amended since these drawings were prepared.
2. All resistance values are indicated in ohms (K = 10^3 , M = 10^6).
3. Resistor wattages are 1/4W or 1/6W unless otherwise specified.
4. All capacitance values are indicated in μF (P = 10^{-6} μF).
5. All voltages are DC voltages unless otherwise specified.

LIST OF CAUTION, NOTES, AND SYMBOLS USED IN THE SCHEMATIC DIAGRAMS ON THE FOLLOWING PAGES:

1. CAUTION:

CAUTION: FOR CONTINUED PROTECTION AGAINST RISK OF FIRE, REPLACE ONLY WITH SAME TYPE_A,_V FUSE.

ATTENTION: UTILISER UN FUSIBLE DE RECHANGE DE MÊME TYPE DE_A,_V.

2. CAUTION:

Fixed Voltage (or Auto voltage selectable) power supply circuit is used in this unit.

If Main Fuse (F1901) is blown, first check to see that all components in the power supply circuit are not defective before you connect the AC plug to the AC power supply. Otherwise it may cause some components in the power supply circuit to fail.

3. Note:

- Do not use the part number shown on the drawings for ordering. The correct part number is shown in the parts list, and may be slightly different or amended since the drawings were prepared.
- To maintain original function and reliability of repaired units, use only original replacement parts which are listed with their part numbers in the parts list section of the service manual.

4. Voltage indications on the schematics are as shown below:

Plug the TV power cord into a standard AC outlet.:

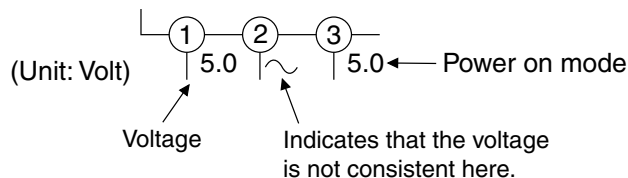

5. How to read converged lines

1-D3
 ↑ Distinction Area
 ↑ Line Number
 (1 to 3 digits)

Examples:

- "1-D3" means that line number "1" goes to the line number "1" of the area "D3".
- "1-B1" means that line number "1" goes to the line number "1" of the area "B1".

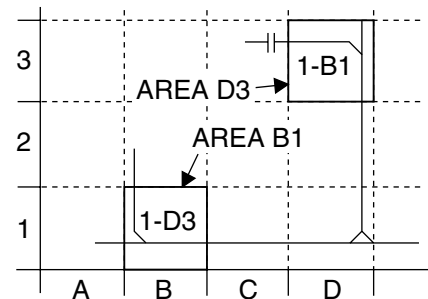

6. Test Point Information

- ⊕ : Indicates a test point with a jumper wire across a hole in the PCB.
- : Used to indicate a test point with a component lead on foil side.
- ⊗ : Used to indicate a test point with no test pin.
- : Used to indicate a test point with a test pin.

Power Supply 1/3 Schematic Diagram

NOTE:
The voltage for parts in hot circuit is measured using hot GND as a common terminal.

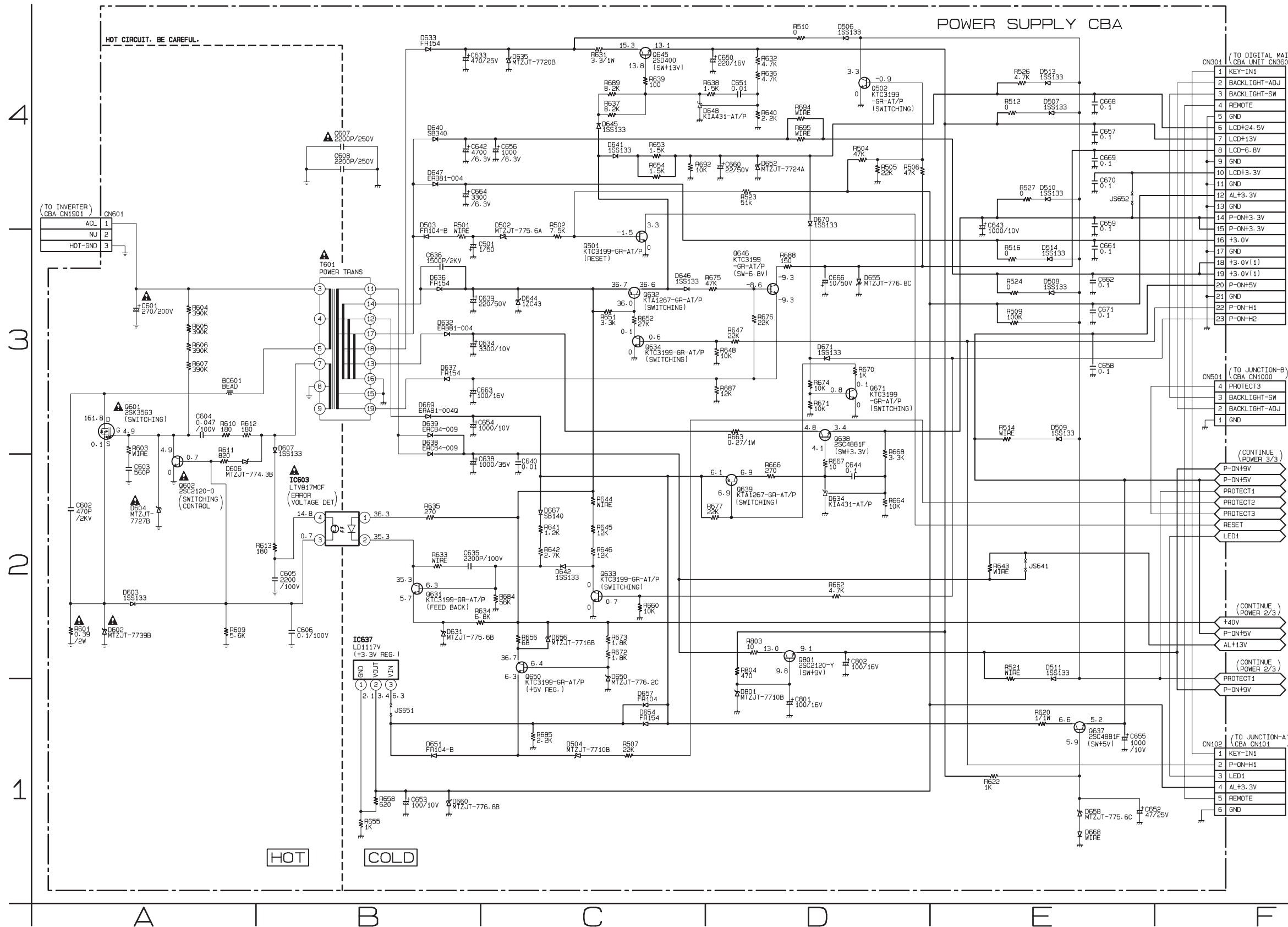

VOLTAGE CHART

Pin No.	Voltage
1	3.3
2	3.2
3	3.2
4	3.3
5	0
6	23.5
7	13.1
8	-6.9
9	0
10	3.4
11	0
12	3.4
13	0
14	3.4
15	3.4
16	3.3
17	0
18	3.4
19	3.4
20	5.2
21	0
22	3.3
23	3.2

Power Supply 2/3 Schematic Diagram

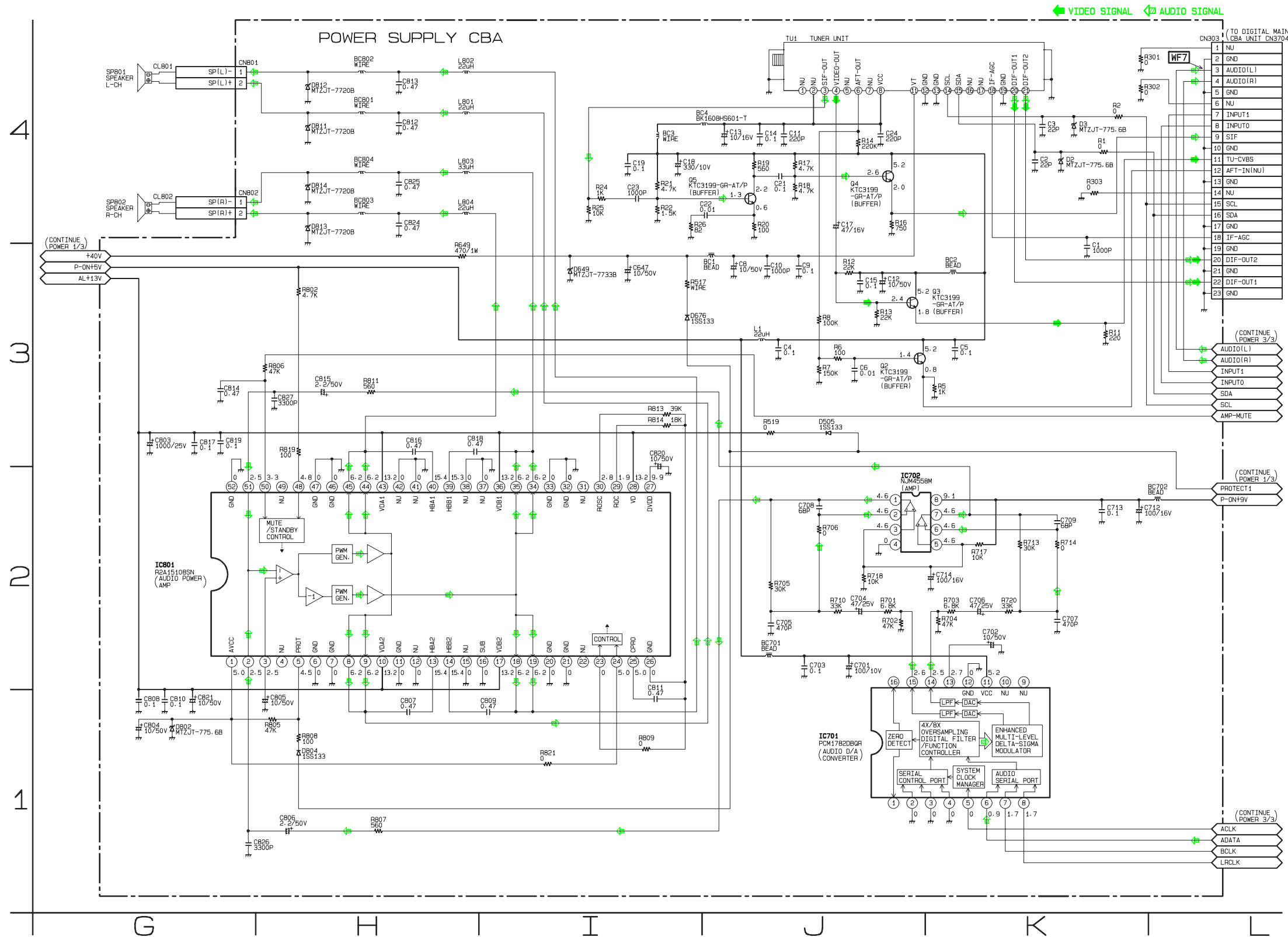

VOLTAGE CHART

CN303	
Pin No.	Voltage
1	---
2	0
3	2.6
4	2.6
5	0
6	---
7	0
8	0
9	2.0
10	0
11	1.7
12	0.8
13	0
14	---
15	4.9
16	4.9
17	0
18	3.3
19	0
20	1.6
21	0
22	1.6
23	0

Power Supply 3/3 Schematic Diagram

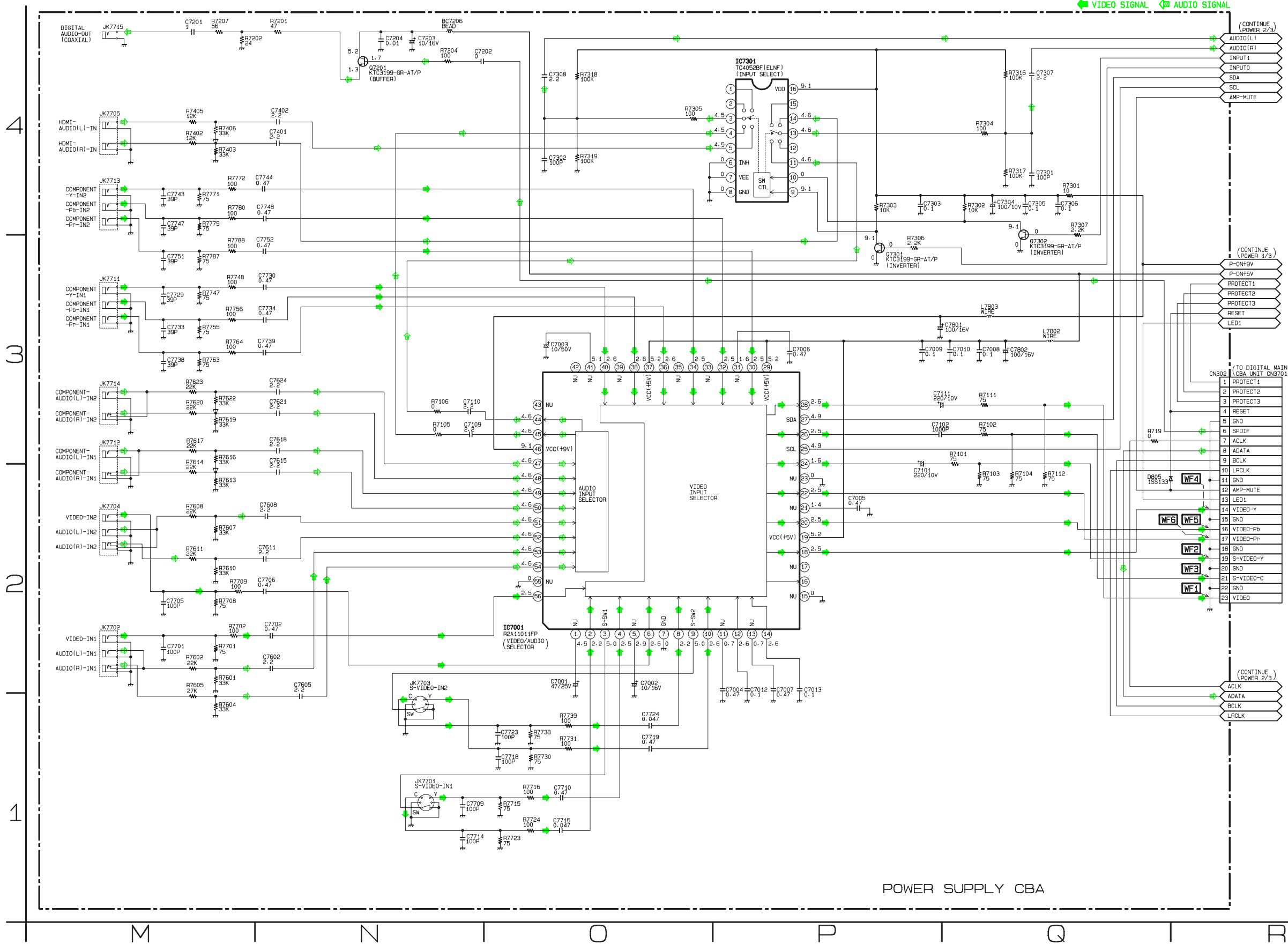

VOLTAGE CHART

CN302

Pin No.	Voltage
1	3.4
2	0
3	3.4
4	3.3
5	0
6	1.7
7	1.6
8	1.3
9	1.7
10	1.7
11	0
12	3.4
13	0.6
14	2.5
15	0
16	2.6
17	2.5
18	0
19	0
20	0
21	0
22	0
23	0

POWER SUPPLY CBA

Inverter & Junction-B Schematic Diagram

CAUTION !

Fixed voltage (or Auto voltage selectable) power supply circuit is used in this unit.
If Main Fuse (F1901) is blown, check to see that all components in the power supply circuit are not defective before you connect the AC plug to the AC power supply.
Otherwise it may cause some components in the power supply circuit to fail.

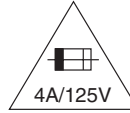

CAUTION ! : For continued protection against risk of fire, replace only with same type 4 A, 125V fuse.
ATTENTION : Utiliser un fusible de rechange de même type de 4A, 125V.

NOTE:

The voltage for parts in hot circuit is measured using hot GND as a common terminal.

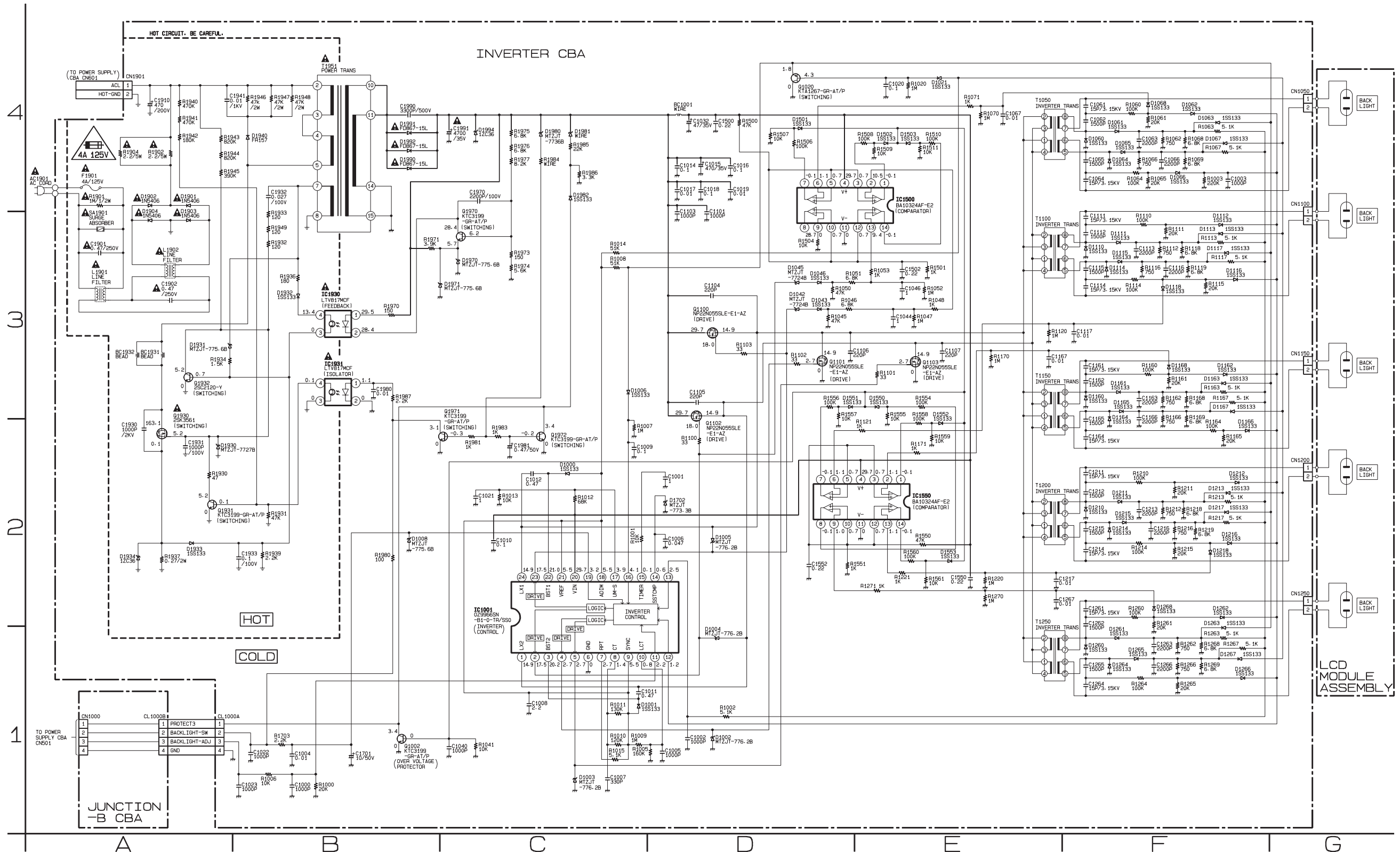

Function Schematic Diagram

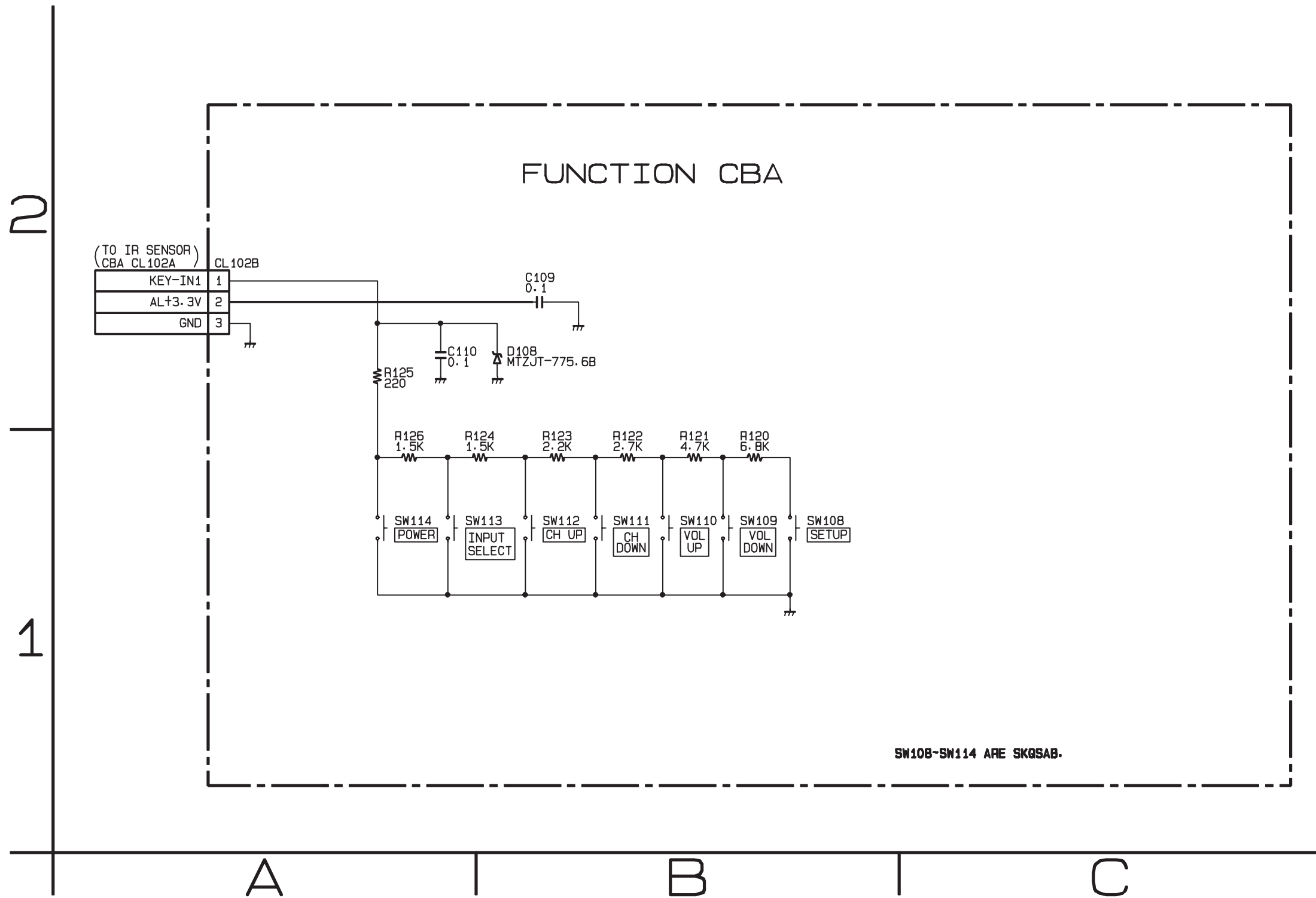

IR Sensor & Junction-A Schematic Diagram

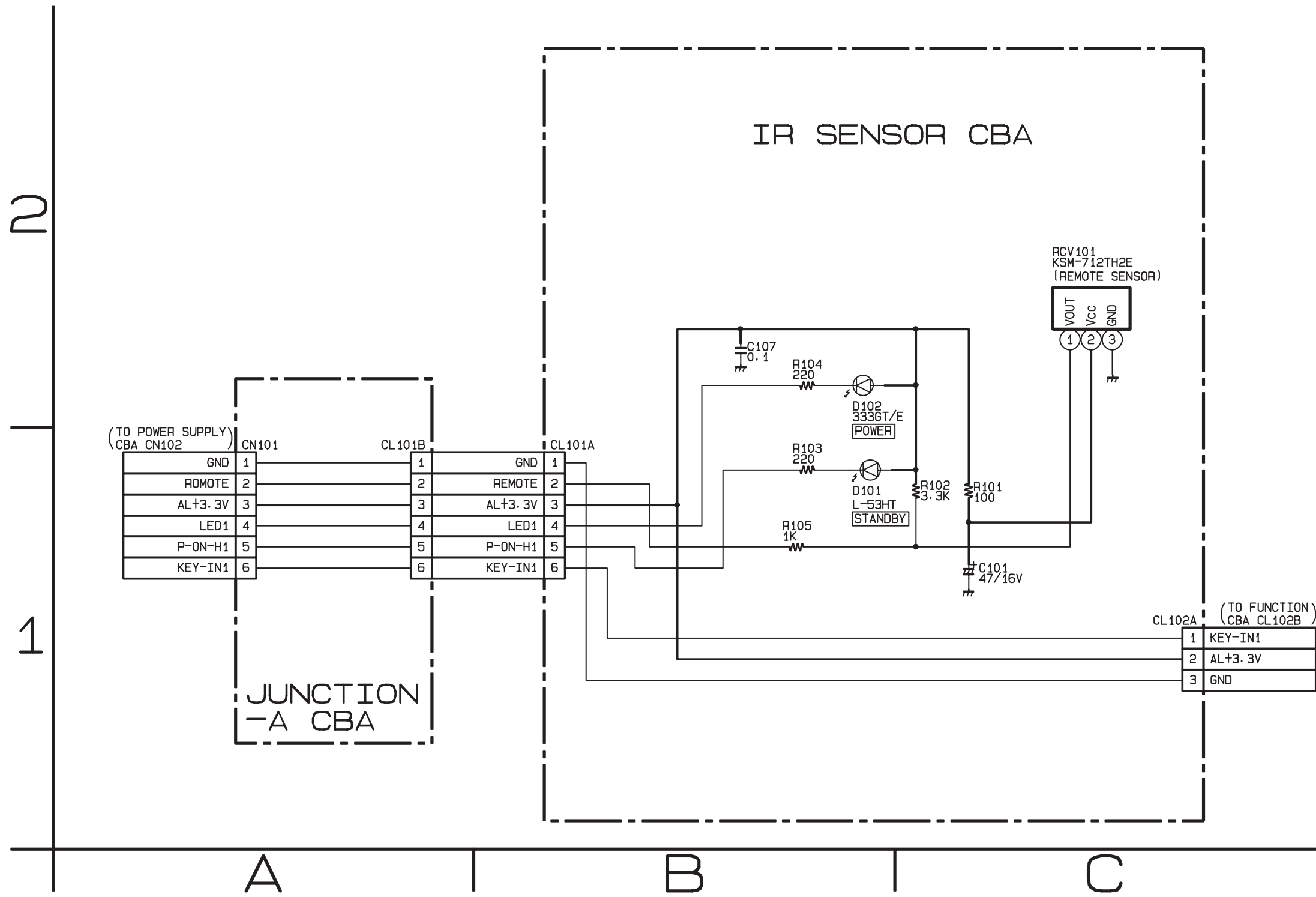

Digital Main 1/4 Schematic Diagram

***1 NOTE:**

The order of pins shown in this diagram is different from that of actual IC3301.
IC3301 is divided into four and shown as IC3301 (1/4) ~ IC3301 (4/4) in this Digital Main Schematic Diagram Section.

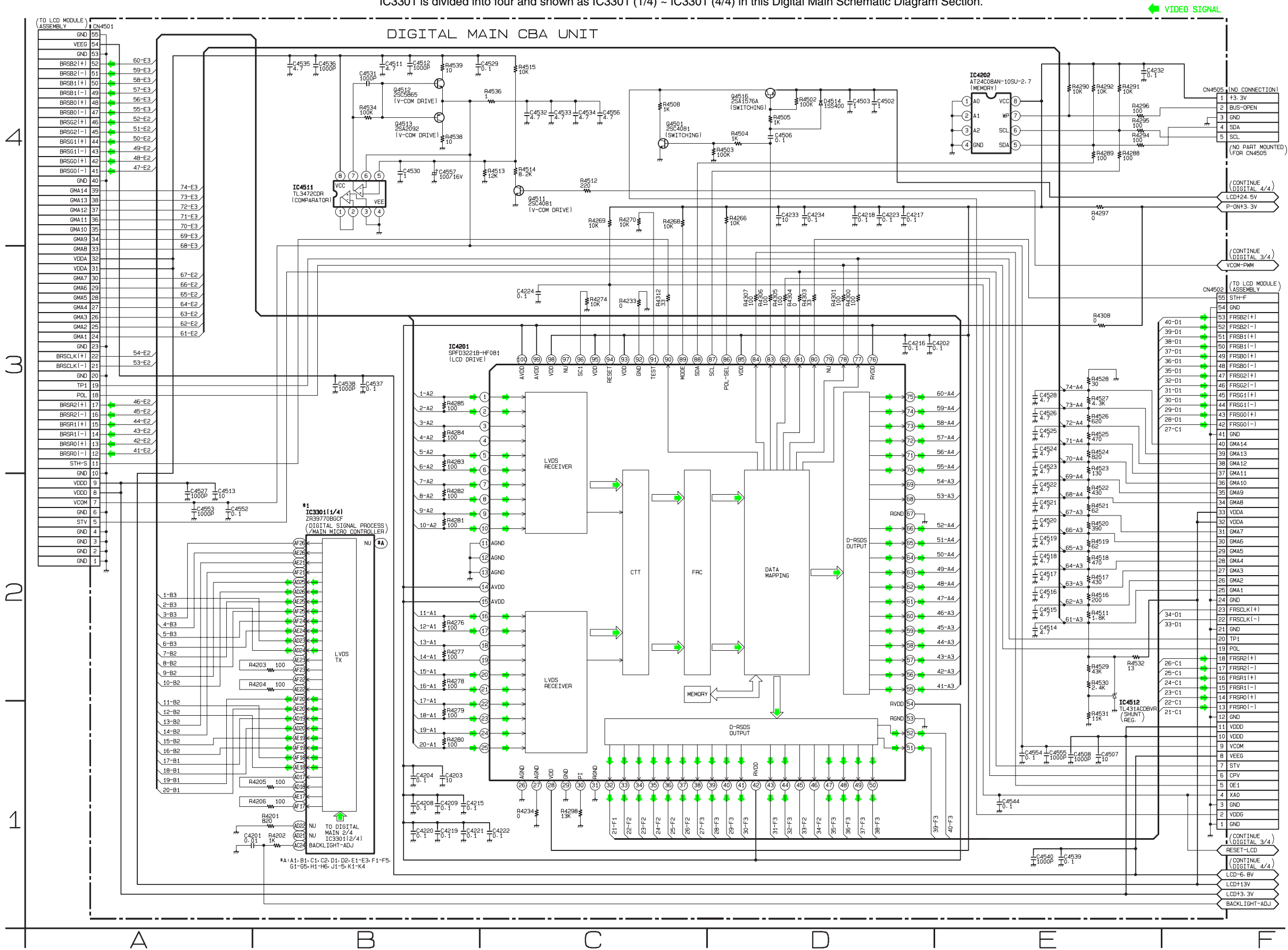

Digital Main 2/4 Schematic Diagram

***1 NOTE:**

The order of pins shown in this diagram is different from that of actual IC3301.
 IC3301 is divided into four and shown as IC3301 (1/4) ~ IC3301 (4/4) in this Digital Main Schematic Diagram Section.

← VIDEO SIGNAL ← AUDIO SIGNAL

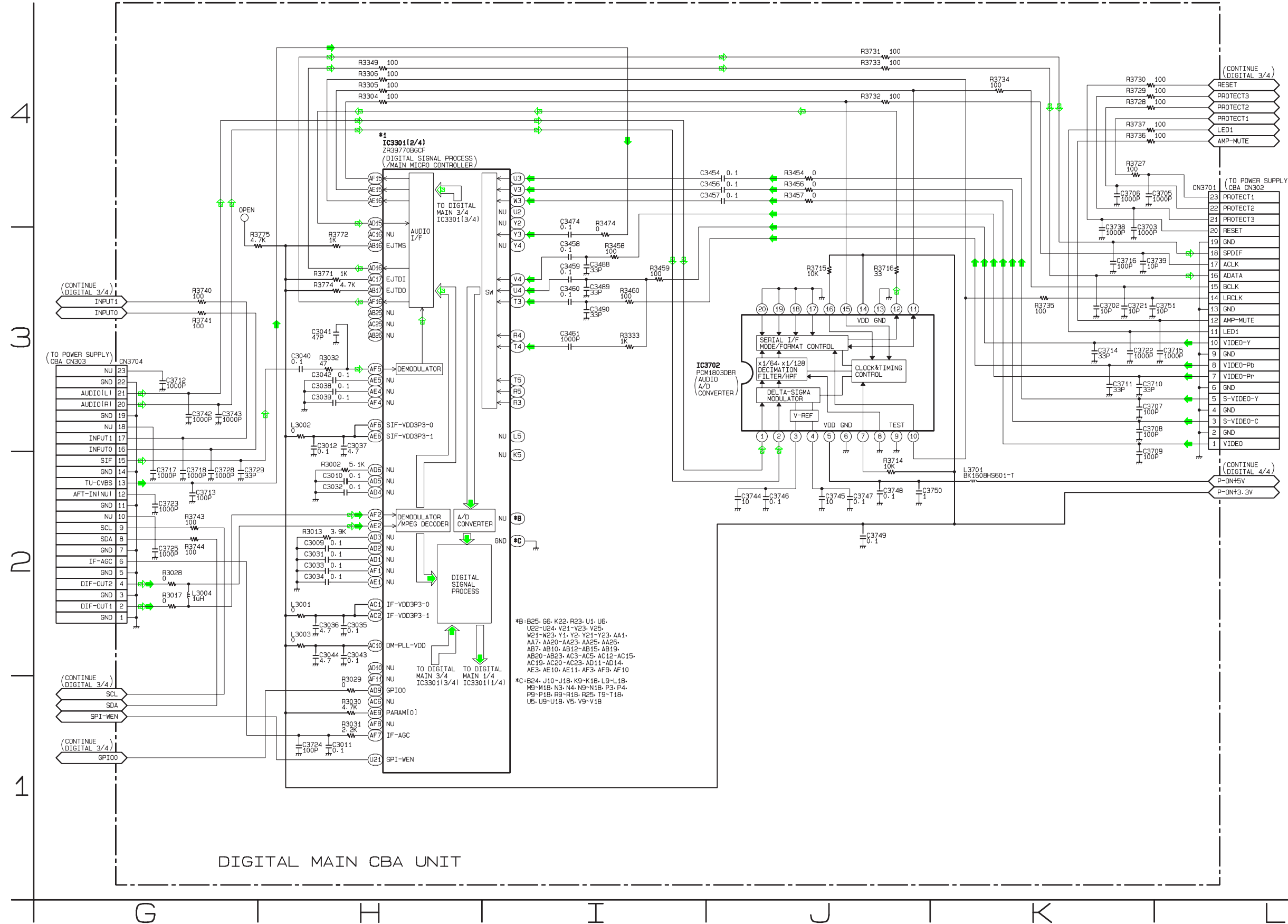

*B: B25, G6, K22, R23, U1, U6, U22, U24, V21, V23, V25, W21, W23, Y1, Y2, Y21, Y23, AA1, AA7, AA20, AA23, AA25, AA26, AB7, AB10, AB12, AB15, AB19, AB20, AB23, AC3, AC5, AC12, AC15, AC19, AC20, AC23, AD11, AD14, AE3, AE10, AE11, AF3, AF9, AF10

*C: B24, J10, J18, K9, K18, L9, L18, M9, M18, N3, N4, N9, N18, P3, P4, P9, P18, R9, R18, R25, T9, T18, U5, U9, U18, V5, V9, V18

Digital Main 3/4 Schematic Diagram

***1 NOTE:**

The order of pins shown in this diagram is different from that of actual IC3301.
IC3301 is divided into four and shown as IC3301 (1/4) ~ IC3301 (4/4) in this Digital Main Schematic Diagram Section.

▶ VIDEO SIGNAL ◀ AUDIO SIGNAL

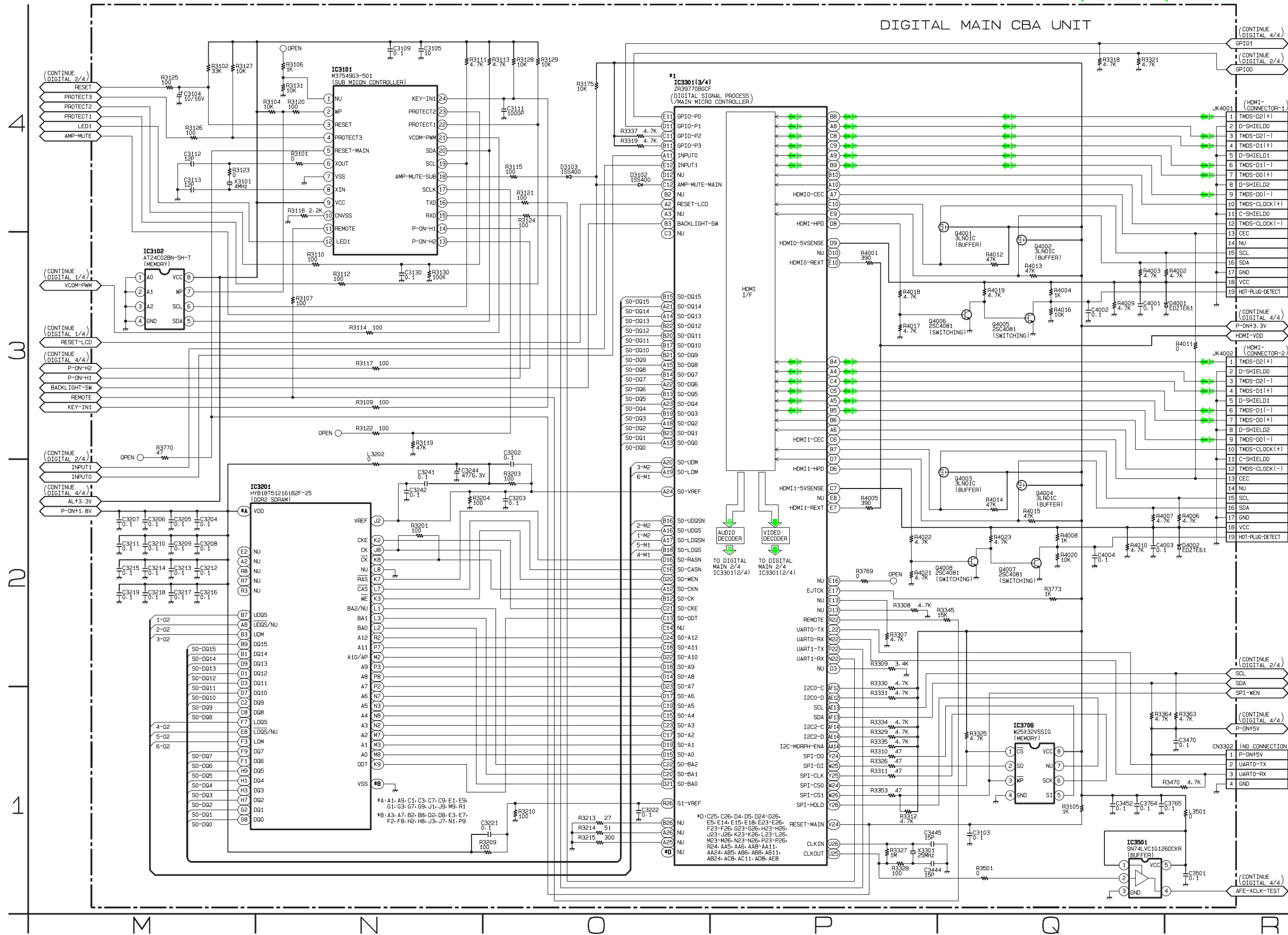

Digital Main 4/4 Schematic Diagram

***1 NOTE:**

The order of pins shown in this diagram is different from that of actual IC3301.
 IC3301 is divided into four and shown as IC3301 (1/4) ~ IC3301 (4/4) in this Digital Main Schematic Diagram Section.

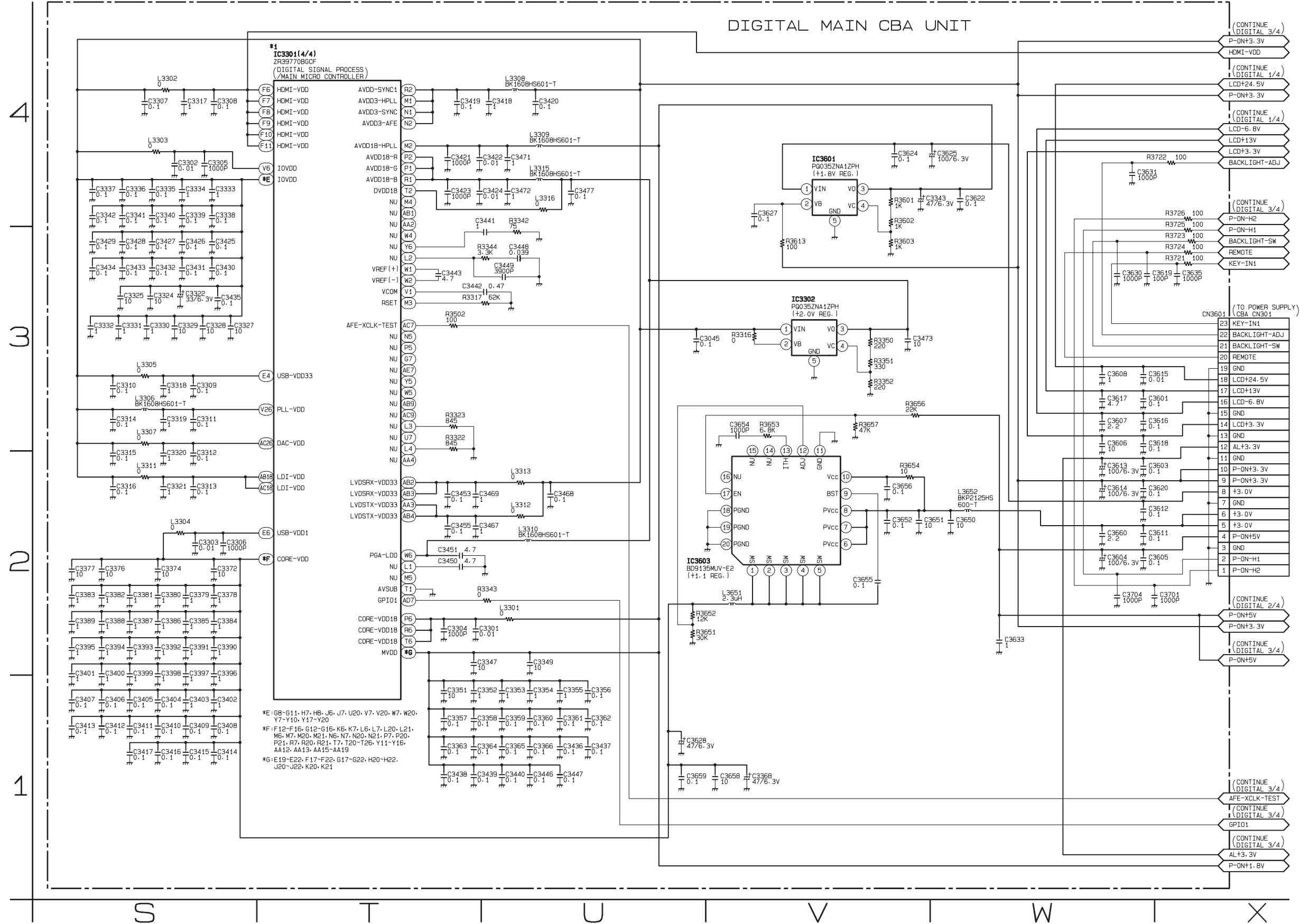

Power Supply CBA Top View

NOTE:
The voltage for parts in hot circuit is measured using hot GND as a common terminal.

Because a hot chassis ground is present in the power supply circuit, an isolation transformer must be used. Also, in order to have the ability to increase the input slowly, when troubleshooting this type power supply circuit, a variable isolation transformer is required.

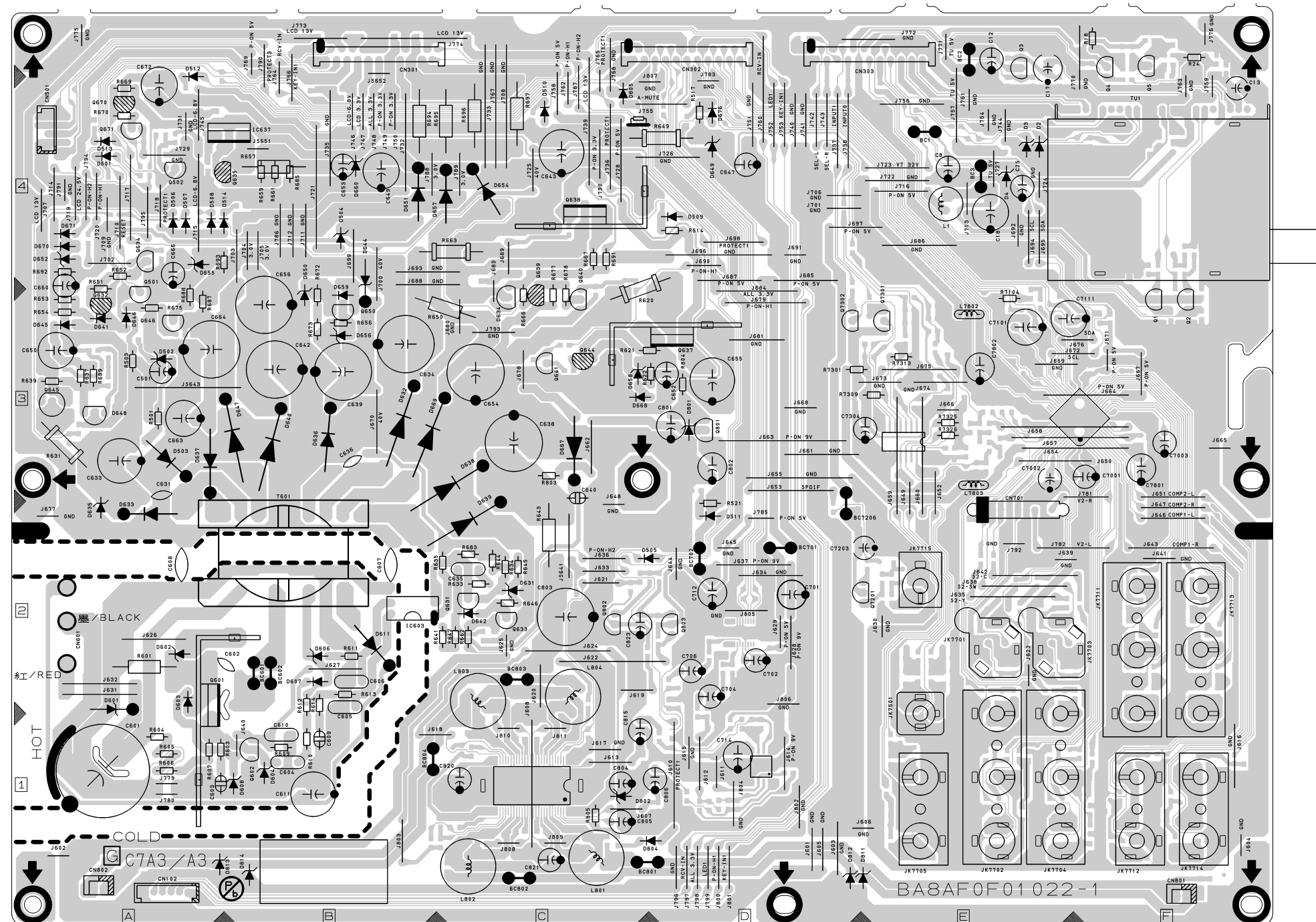

Power Supply CBA Bottom View

NOTE:
The voltage for parts in hot circuit is measured using hot GND as a common terminal.

Because a hot chassis ground is present in the power supply circuit, an isolation transformer must be used. Also, in order to have the ability to increase the input slowly, when troubleshooting this type power supply circuit, a variable isolation transformer is required.

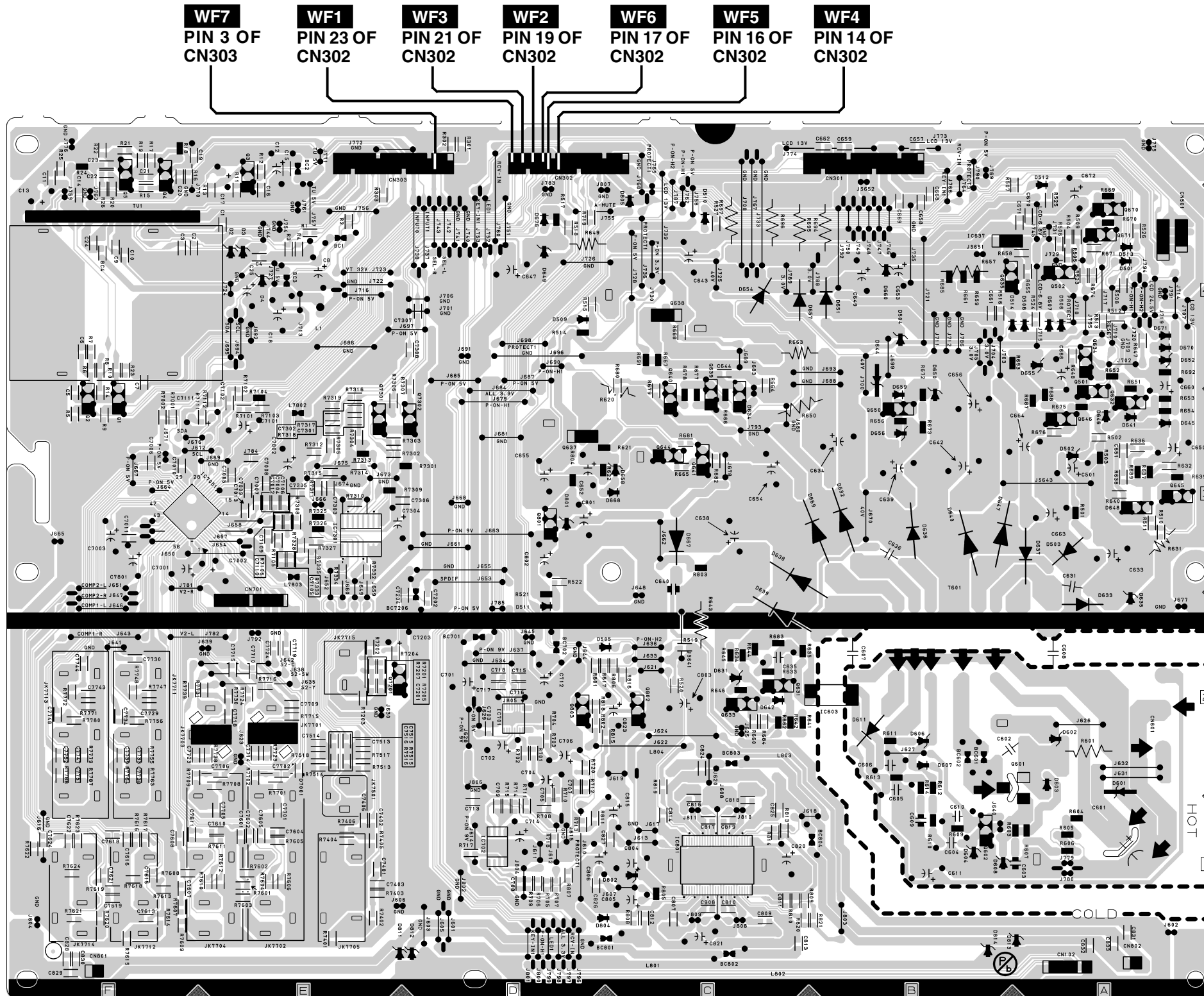

Inverter CBA Top View

CAUTION !

Fixed voltage (or Auto voltage selectable) power supply circuit is used in this unit.
If Main Fuse (F1901) is blown , check to see that all components in the power supply circuit are not defective before you connect the AC plug to the AC power supply.
Otherwise it may cause some components in the power supply circuit to fail.

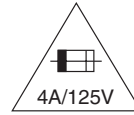

CAUTION ! : For continued protection against risk of fire, replace only with same type 4 A, 125V fuse.
ATTENTION : Utiliser un fusible de rechange de même type de 4A, 125V.

Because a hot chassis ground is present in the power supply circuit, an isolation transformer must be used. Also, in order to have the ability to increase the input slowly, when troubleshooting this type power supply circuit, a variable isolation transformer is required.

NOTE:

The voltage for parts in hot circuit is measured using hot GND as a common terminal.

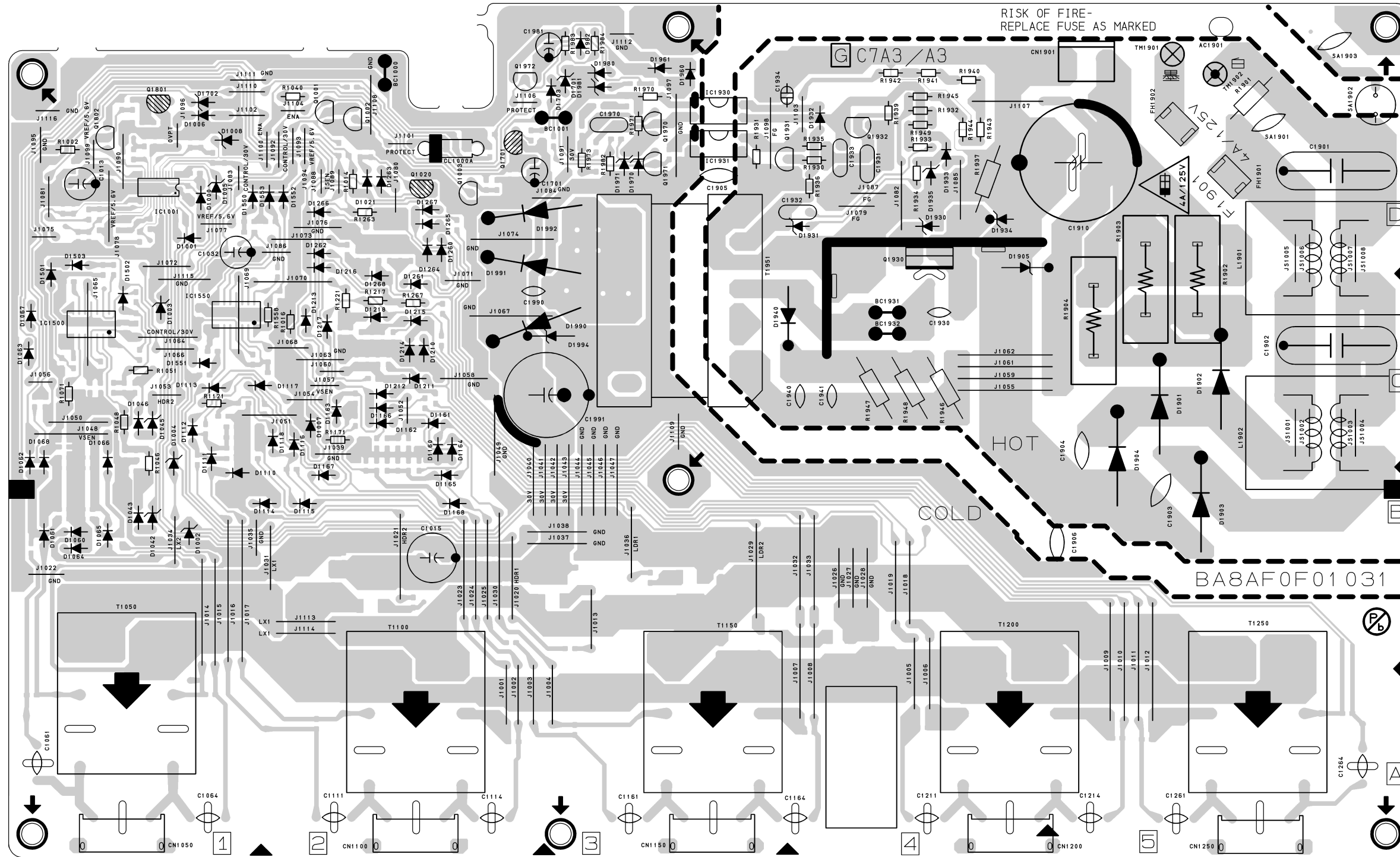

Inverter CBA Bottom View

CAUTION !

Fixed voltage (or Auto voltage selectable) power supply circuit is used in this unit. If Main Fuse (F1901) is blown, check to see that all components in the power supply circuit are not defective before you connect the AC plug to the AC power supply. Otherwise it may cause some components in the power supply circuit to fail.

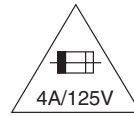

CAUTION ! : For continued protection against risk of fire, replace only with same type 4 A, 125V fuse.
ATTENTION : Utiliser un fusible de rechange de même type de 4A, 125V.

Because a hot chassis ground is present in the power supply circuit, an isolation transformer must be used. Also, in order to have the ability to increase the input slowly, when troubleshooting this type power supply circuit, a variable isolation transformer is required.

NOTE:

The voltage for parts in hot circuit is measured using hot GND as a common terminal.

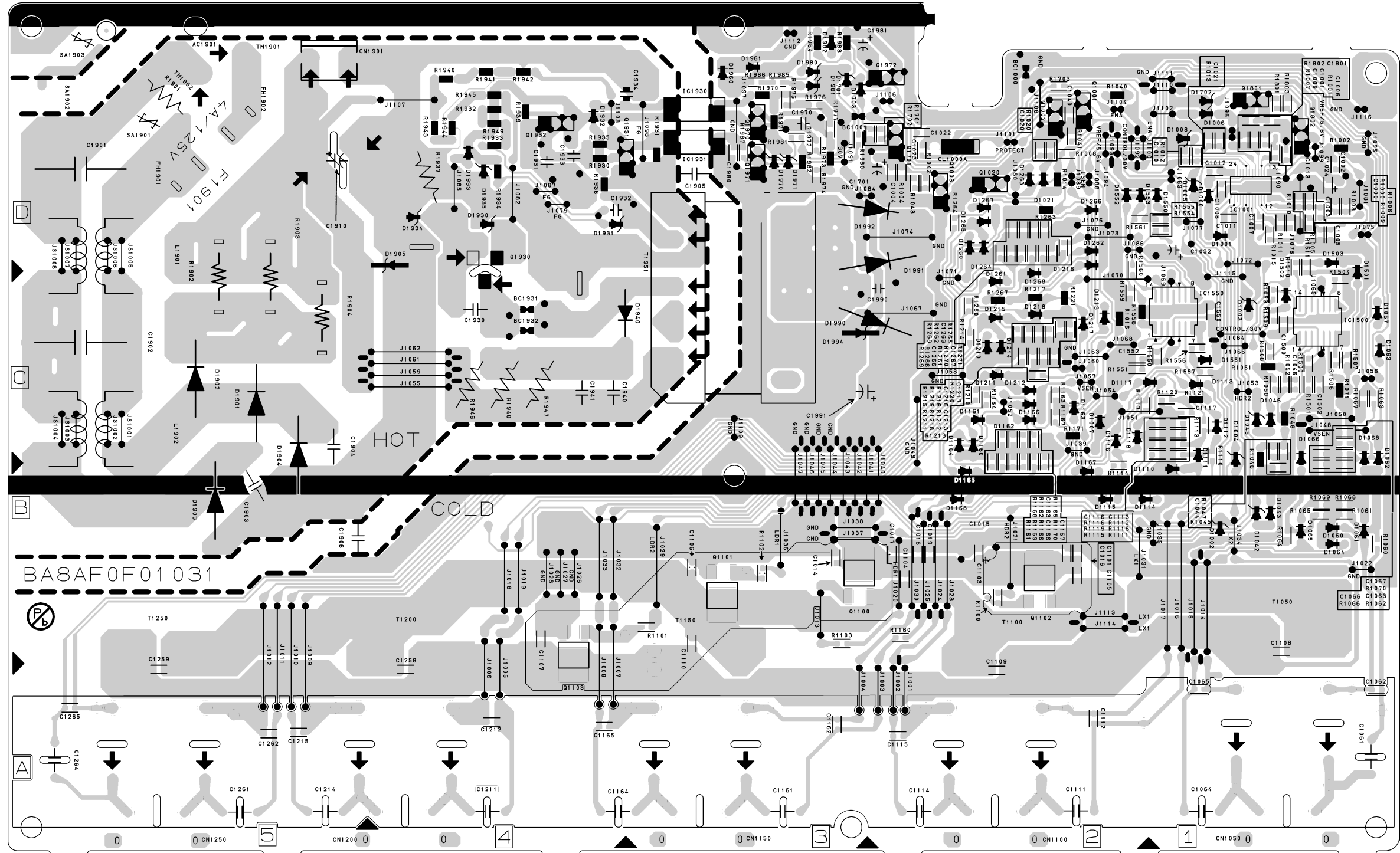

**Junction-A CBA
Top View**

**Junction-A CBA
Bottom View**

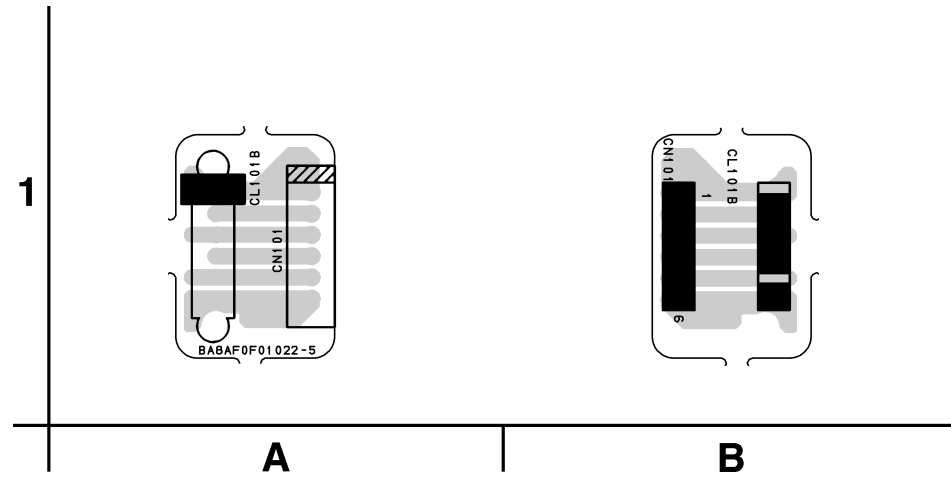

BA8AF0F01022-5

**Junction-B CBA
Top View**

**Junction-B CBA
Bottom View**

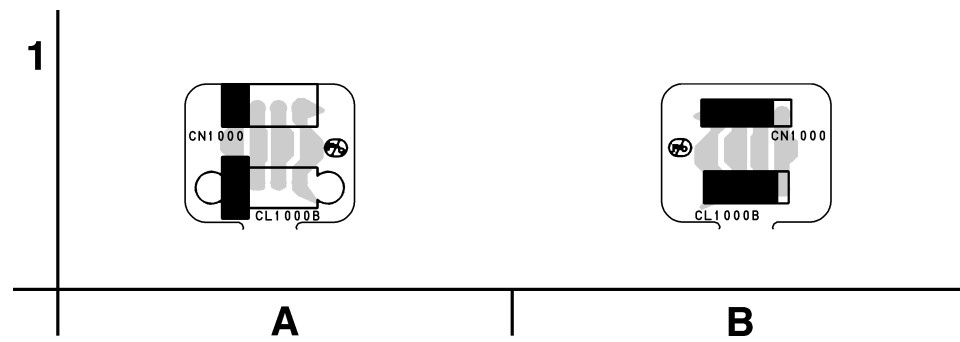

BA8AF0F01031

WAVEFORMS

WF1 ~ WF7 = Waveforms to be observed at
Waveform check points.
(Shown in Schematic Diagram.)

Input: NTSC Color Bar Signal (with 1kHz Audio Signal)

WF1 Pin 23 of CN302

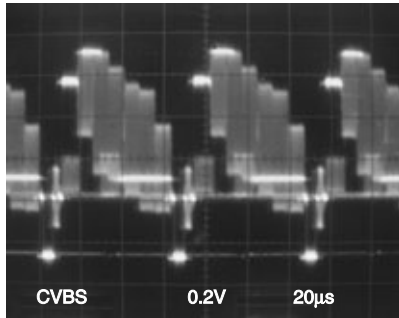

WF5 Pin 16 of CN302

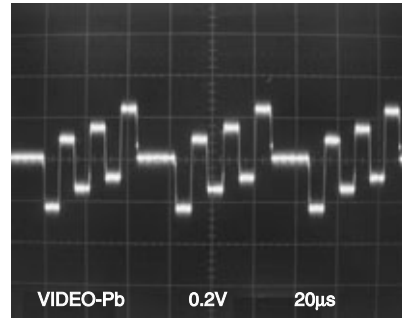

WF2 Pin 19 of CN302

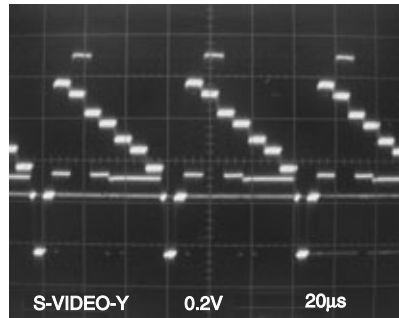

WF6 Pin 17 of CN302

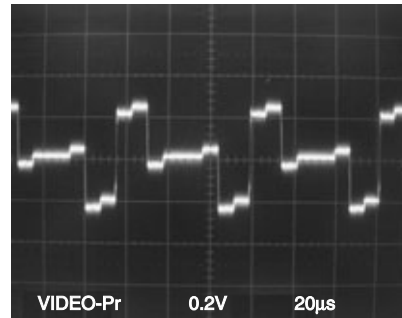

WF3 Pin 21 of CN302

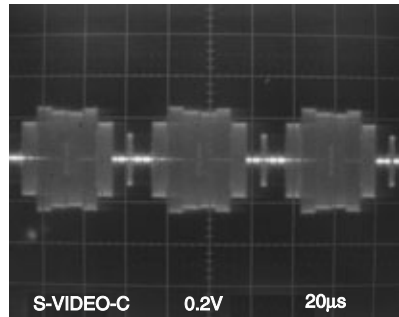

WF7 Pin 3 of CN303

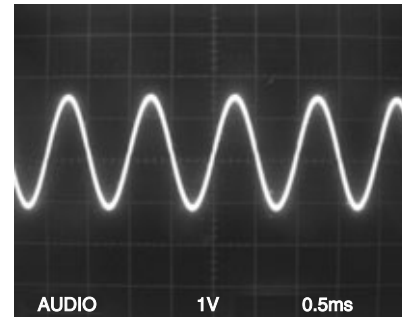

WF4 Pin 14 of CN302

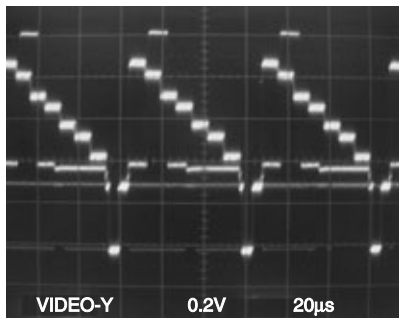

WIRING DIAGRAM

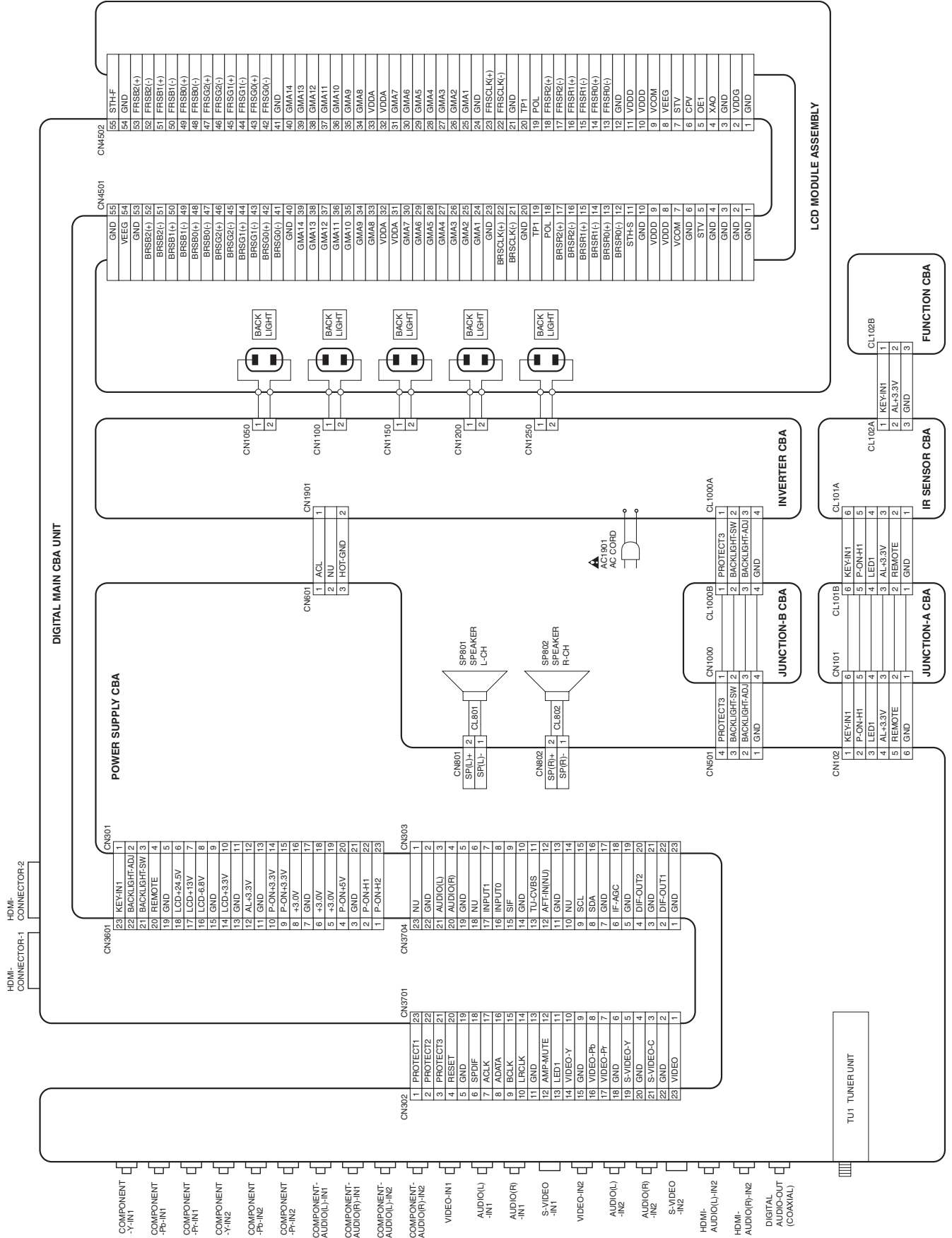

Packing

Some Ref. Numbers are not in sequence.

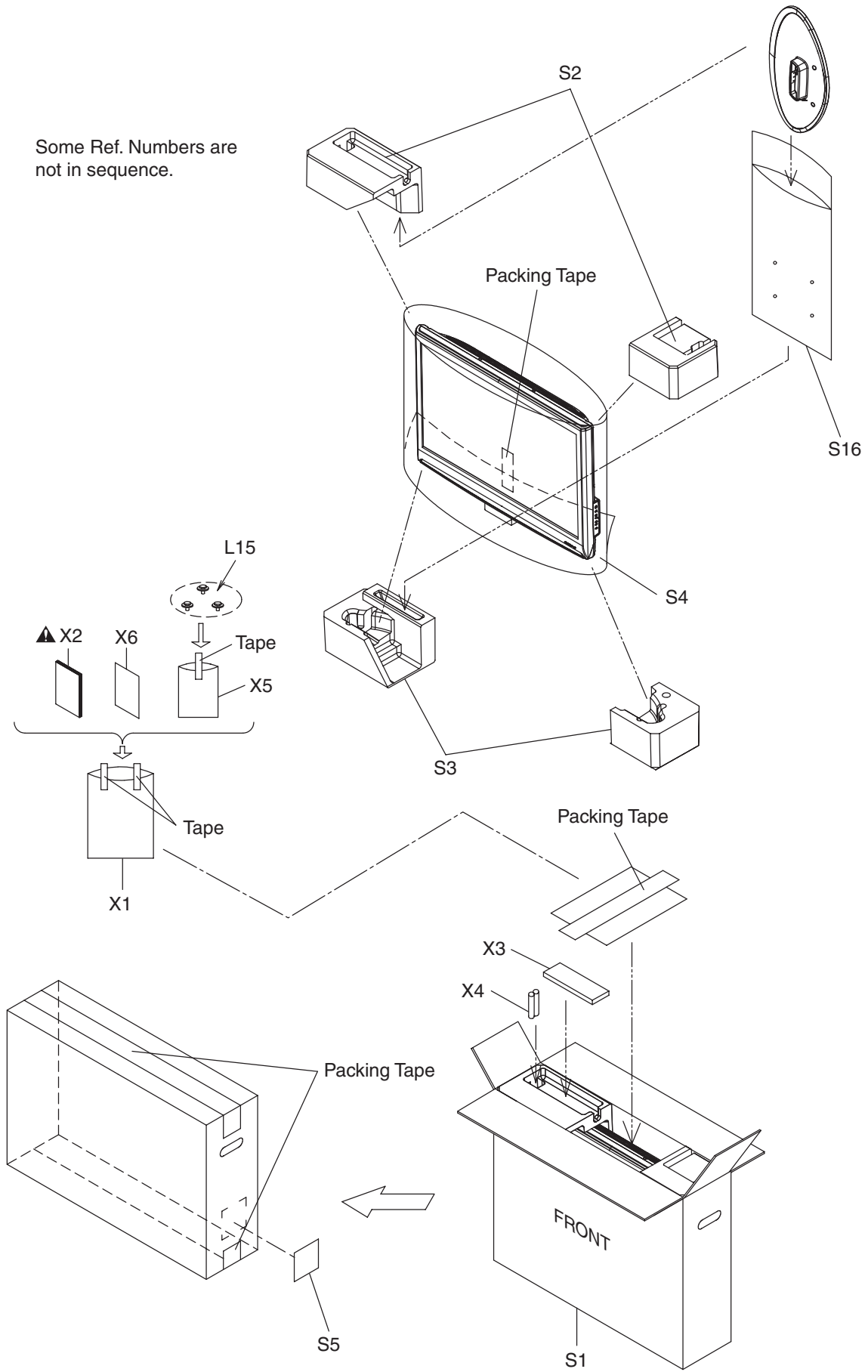

MECHANICAL PARTS LIST

PRODUCT SAFETY NOTE: Products marked with a  have special characteristics important to safety. Before replacing any of these components, read carefully the product safety notice in this service manual. Don't degrade the safety of the product through improper servicing.

NOTE: Parts that are not assigned part numbers (-----) are not available.

Ref. No.	Description	Part No.
X2 	OWNERS MANUAL A8AF1UH	1EMN22959
X3	REMOTE CONTROL NF027UD 170/ ECNLC6.501/NF027	NF027UD
X4	DRY BATTERY(SUNRISE) R6SSE/2S	XB0M451MS002
X5	SCREW BAG A81N0UH	1EM424596A
X6	QUICK SETUP GUIDE A8AF1UH	1EMN22999A

Ref. No.	Description	Part No.
A1	FRONT CABINET A8AF1UH	1EM022265
A3	CONTROL PLATE A8AF0UH	1EM323600
A4	REAR CABINET A8AF1UH	1EM022266
A6 	RATING LABEL A8AF1UH	-----
A7	FUNCTION KNOB A8AF0UH	1EM122273
A9	STAND COVER A8AF1UH	1EM122413
A10	REAR COVER A8AF0UH	1EM323717
A11	LED LENS A8AF1UH	1EM323799
A12	STAND RUBBER FOOT L5001CB	1EM423855
A26	LOGO LABEL A8AF1UH	-----
B1	PCB HOLDER (L) A8AF0UH	1EM122274
B2	PCB HOLDER (R) A8AF0UH	1EM122275
B3	SHIELD BOX A8AF0UH	1EM222004
B4	SHIELD (T) A8AF0UH	1EM323599
B7	STAND BASE PLATE A8AF0UH	1EM122276
B8	STAND HINGE A8AF0UH	1EM323598
B9	STAND HOLDER 32V A8AF0UH	1EM222005
B10	STAND HOLDER A81N0UH	1EM322709
B11	SPEAKER HOLDER (L) A8AF1UH	1EM323480
B12	SPEAKER HOLDER (R) A8AF1UH	1EM323800
B22	CLOTH(10X180XT0.5) L0336JG	0EM408827
B30	GASKET A8AF0UH	1EM425861
B40	WASHER(D17) A73F2FP	1EM425638
CL801	WIRE ASSEMBLY 005 2PIN / 170MM / AWG24	WX1A8AF0-005
CL802	WIRE ASSEMBLY 005 2PIN / 170MM / AWG24	WX1A8AF0-005
CL4501	WIRE ASSEMBLY 010 55PIN / 60MM	WX1A8AF0-010
CL4502	WIRE ASSEMBLY 010 55PIN / 60MM	WX1A8AF0-010
L2	SCREW P-TIGHT M4X14 BIND HEAD+BLK	GBHP4140
L4	SCREW P-TIGHT M3X12 DISH HEAD+	GDJP3120
L6	SCREW P-TIGHT 3X10 BIND HEAD+	GBHP3100
L9	SCREW S-TIGHT M3X4 BIND HEAD+BLK	GBHS3040
L10	SCREW S-TIGHT M3X6 BIND HEAD+	GBJS3060
L13	DOUBLE SEMS SCREW M4X6 M4X6	FPJ34060
L15	DOUBLE SEMS SCREW M4X10 + BLK	FPJ34100
L17	ASSEMBLED SCREW (D9 M3X6) A71F0UH	1EM424392A
L18	NUT 3/8-32UNEF	0EM401451A
LCD1	32INCH LCD MODULE LCD 32INCH	UG320XA
SP801	SPEAKER MAGNETIC S0412F06A	DSD0809XQ006
SP802	SPEAKER MAGNETIC S0412F06A	DSD0809XQ006
PACKING		
S1	CARTON A8AF1UH	1EM425737
S2	STYROFOAM TOP A8AF1UH	1EM022366
S3	STYROFOAM BOTTOM A8AF1UH	1EM022367
S4	SET BAG A71FCUH	1EM323657
S5	RFID LABEL P7100UM	-----
S16	STAND BAG A71FCUH	1EM425338
ACCESSORIES		
X1	BAG POLYETHYLENE 235X365XT0.03	0EM408420A

ELECTRICAL PARTS LIST

PRODUCT SAFETY NOTE: Products marked with a **▲** have special characteristics important to safety. Before replacing any of these components, read carefully the product safety notice in this service manual. Don't degrade the safety of the product through improper servicing.

NOTES:

- Parts that are not assigned part numbers (-----) are not available.
- Tolerance of Capacitors and Resistors are noted with the following symbols.

C.....±0.25% D.....±0.5% F.....±1%
 G.....±2% J.....±5% K.....±10%
 M.....±20% N.....±30% Z.....+80/-20%

DIGITAL MAIN CBA UNIT

Ref. No.	Description	Part No.
	DIGITAL MAIN CBA UNIT	1ESA16685

MPS CBA

Ref. No.	Description	Part No.
	MPS CBA Consists of the following	1ESA16506
	POWER SUPPLY CBA(MPS-1)	-----
	FUNCTION CBA(MPS-3)	-----
	IR SENSOR CBA(MPS-4)	-----
	JUNCTION-A CBA(MPS-5)	-----

POWER SUPPLY CBA

Ref. No.	Description	Part No.
	POWER SUPPLY CBA(MPS-1) Consists of the following:	-----
CAPACITORS		
C1	CHIP CERAMIC CAP.(1608) CH J 1000pF/50V	CHD1JJ3CH102
C2	CHIP CERAMIC CAP.(1608) CH J 22pF/50V	CHD1JJ3CH220
C3	CHIP CERAMIC CAP.(1608) CH J 22pF/50V	CHD1JJ3CH220
C4	CHIP CERAMIC CAP.(1608) F Z 0.1µF/25V	CHD1EZ30F104
C5	CHIP CERAMIC CAP.(1608) F Z 0.1µF/25V	CHD1EZ30F104
C6	CHIP CERAMIC CAP.(1608) B K 0.01µF/50V	CHD1JK30B103
C8	ELECTROLYTIC CAP. 10µF/50V M	CE1JMASDL100
C9	CHIP CERAMIC CAP.(1608) F Z 0.1µF/50V	CHD1JZ30F104
C10	CHIP CERAMIC CAP.(1608) CH J 1000pF/50V	CHD1JJ3CH102
C11	CHIP CERAMIC CAP. CH J 220pF/50V	CHD1JJ3CH221
C12	ELECTROLYTIC CAP. 10µF/50V M	CE1JMASDL100
C13	ELECTROLYTIC CAP. 10µF/16V M H7	CE1CMAVSL100
C14	CHIP CERAMIC CAP.(1608) F Z 0.1µF/25V	CHD1EZ30F104
C15	CHIP CERAMIC CAP.(1608) F Z 0.1µF/25V	CHD1EZ30F104
C17	ELECTROLYTIC CAP. 47µF/16V M H7	CE1CMAVSL470
C18	ELECTROLYTIC CAP. 330µF/10V M	CE1AMASDL331
C19	CHIP CERAMIC CAP.(1608) F Z 0.1µF/25V	CHD1EZ30F104
C21	CHIP CERAMIC CAP.(1608) F Z 0.1µF/25V	CHD1EZ30F104
C22	CHIP CERAMIC CAP.(1608) B K 0.01µF/50V	CHD1JK30B103
C23	CHIP CERAMIC CAP.(1608) CH J 1000pF/50V	CHD1JJ3CH102
C24	CHIP CERAMIC CAP. CH J 220pF/50V	CHD1JJ3CH221
C501	ELECTROLYTIC CAP. 1µF/50V M	CE1JMASDL1R0

Ref. No.	Description	Part No.
C601▲	ELECTROLYTIC CAPACITOR 270µF/200V	CA2D271DYG05
C602	CERAMIC CAP. HR 470pF/2KV	CCD3DKA0R471
C603	CAP CERAMIC (AX) 560pF/50V/B/K	CA1J561TU061
C604	POLYESTER FILM CAP. (PB FREE) 0.047µF/100V J	CA2A473DT018
C605	POLYESTER FILM CAP. (PB FREE) 0.0022µF/100V J	CA2A222DT018
C606	POLYESTER FILM CAP. (PB FREE) 0.1µF/100V J	CA2A104DT018
C607▲	SAFTY CAP. 2200pF/250V KX	CA2E222MR101
C608	SAFTY CAP. 2200pF/250V KX	CA2E222MR101
C633	ELECTROLYTIC CAP. 470µF/25V M	CE1EMASDL471
C634	ELECTROLYTIC CAP. 3300µF/10V	CE1AMZNDL332
C635	POLYESTER FILM CAP. (PB FREE) 0.0022µF/100V J	CA2A222DT018
C636	CERAMIC CAP. R K 1500pF/2KV(HR)	CCD3DKA0R152
C638	ELECTROLYTIC CAP. 1000µF/35V M	CE1GMZADL102
C639	ELECTROLYTIC CAP. 220µF/50V M	CE1JMASDL221
C640	CAP CERAMIC (AX) 0.01µF/50V/B/K	CA1J103TU061
C642	CAP ELE STD-85 4700µF 6.3V SL	CE0KMZNDL472
C643	ELECTROLYTIC CAP. 1000µF/10V M	CE1AMASDL102
C644	CHIP CERAMIC CAP.(1608) B K 0.1µF/50V	CHD1JK30B104
C647	ELECTROLYTIC CAP. 10µF/50V M	CE1JMASDL100
C650	ELECTROLYTIC CAP. 220µF/16V M	CE1CMASDL221
C651	CHIP CERAMIC CAP.(1608) B K 0.01µF/50V	CHD1JK30B103
C652	ELECTROLYTIC CAP. 47µF/25V M	CE1EMASDL470
C653	ELECTROLYTIC CAP. 100µF/10V M	CE1AMASDL101
C654	ELECTROLYTIC CAP. 1000µF/10V M	CE1AMASDL102
C655	ELECTROLYTIC CAP. 1000µF/10V M	CE1AMASDL102
C656	ELECTROLYTIC CAP. 1000µF/6.3V M	CE0KMASDL102
C657	CHIP CERAMIC CAP.(1608) F Z 0.1µF/25V	CHD1EZ30F104
C658	CHIP CERAMIC CAP.(1608) F Z 0.1µF/25V	CHD1EZ30F104
C659	CHIP CERAMIC CAP.(1608) F Z 0.1µF/25V	CHD1EZ30F104
C660	ELECTROLYTIC CAP. 22µF/50V M	CE1JMASDL220
C661	CHIP CERAMIC CAP.(1608) F Z 0.1µF/25V	CHD1EZ30F104
C662	CHIP CERAMIC CAP.(1608) F Z 0.1µF/25V	CHD1EZ30F104
C663	ELECTROLYTIC CAP. 100µF/16V M	CE1CMASDL101
C664	ELECTROLYTIC CAP. 3300µF/6.3V M	CE0KMZNDL332
C666	ELECTROLYTIC CAP. 10µF/50V M	CE1JMASDL100
C668	CHIP CERAMIC CAP.(1608) F Z 0.1µF/50V	CHD1JZ30F104
C669	CHIP CERAMIC CAP.(1608) F Z 0.1µF/25V	CHD1EZ30F104
C670	CHIP CERAMIC CAP.(1608) F Z 0.1µF/25V	CHD1EZ30F104
C671	CHIP CERAMIC CAP.(1608) F Z 0.1µF/25V	CHD1EZ30F104
C701	ELECTROLYTIC CAP. 100µF/10V M	CE1AMASDL101
C702	ELECTROLYTIC CAP. 10µF/50V M	CE1JMASDL100
C703	CHIP CERAMIC CAP.(1608) F Z 0.1µF/25V	CHD1EZ30F104
C704	ELECTROLYTIC CAP. 47µF/25V M	CE1EMASDL470
C705	CHIP CERAMIC CAP. B K 470pF/50V	CHD1JK30B471
C706	ELECTROLYTIC CAP. 47µF/25V M	CE1EMASDL470
C707	CHIP CERAMIC CAP. B K 470pF/50V	CHD1JK30B471
C708	CHIP CERAMIC CAP.(1608) CH J 68pF/50V	CHD1JJ3CH680
C709	CHIP CERAMIC CAP.(1608) CH J 68pF/50V	CHD1JJ3CH680
C712	ELECTROLYTIC CAP. 100µF/16V M	CE1CMASDL101
C713	CHIP CERAMIC CAP.(1608) F Z 0.1µF/25V	CHD1EZ30F104
C714	ELECTROLYTIC CAP. 100µF/16V M	CE1CMASDL101
C801	ELECTROLYTIC CAP. 100µF/16V M	CE1CMASDL101
C802	ELECTROLYTIC CAP. 100µF/16V M	CE1CMASDL101
C803	ELECTROLYTIC CAP. 1000µF/25V M	CE1EMZNDL102
C804	ELECTROLYTIC CAP. 10µF/50V M	CE1JMASDL100
C805	ELECTROLYTIC CAP. 10µF/50V M	CE1JMASDL100
C806	ELECTROLYTIC CAP. 2.2µF/50V M	CE1JMASDL2R2

Ref. No.	Description	Part No.
C807	CHIP CERAMIC CAP.(1608) B K 0.47μF/16V	CHD1CK30B474
C808	CHIP CERAMIC CAP.(1608) B K 0.1μF/50V	CHD1JK30B104
C809	CHIP CERAMIC CAP.(1608) B K 0.47μF/16V	CHD1CK30B474
C810	CHIP CERAMIC CAP.(1608) B K 0.1μF/50V	CHD1JK30B104
C811	CHIP CERAMIC CAP.(1608) B K 0.47μF/10V	CHD1AK30B474
C812	CHIP CERAMIC CAP.(1608) B K 0.47μF/10V	CHD1AK30B474
C813	CHIP CERAMIC CAP.(1608) B K 0.47μF/10V	CHD1AK30B474
C814	CHIP CERAMIC CAP. F Z 0.47μF/16V	CHD1CZ30F474
C815	ELECTROLYTIC CAP. 2.2μF/50V M	CE1JMASDL2R2
C816	CHIP CERAMIC CAP.(1608) B K 0.47μF/16V	CHD1CK30B474
C817	CHIP CERAMIC CAP.(1608) B K 0.1μF/50V	CHD1JK30B104
C818	CHIP CERAMIC CAP.(1608) B K 0.47μF/16V	CHD1CK30B474
C819	CHIP CERAMIC CAP.(1608) B K 0.1μF/50V	CHD1JK30B104
C820	ELECTROLYTIC CAP. 10μF/50V M	CE1JMASDL100
C821	ELECTROLYTIC CAP. 10μF/50V M	CE1JMASDL100
C824	CHIP CERAMIC CAP.(1608) B K 0.47μF/10V	CHD1AK30B474
C825	CHIP CERAMIC CAP.(1608) B K 0.47μF/10V	CHD1AK30B474
C826	CHIP CERAMIC CAP.(1608) B K 3300pF/50V	CHD1JK30B332
C827	CHIP CERAMIC CAP.(1608) B K 3300pF/50V	CHD1JK30B332
C7001	ELECTROLYTIC CAP. 47μF/25V M	CE1EMASDL470
C7002	ELECTROLYTIC CAP. 10μF/16V M H7	CE1CMAVSL100
C7003	ELECTROLYTIC CAP. 10μF/50V M	CE1JMASDL100
C7004	CHIP CERAMIC CAP. F Z 0.47μF/16V	CHD1CZ30F474
C7005	CHIP CERAMIC CAP. F Z 0.47μF/16V	CHD1CZ30F474
C7006	CHIP CERAMIC CAP. F Z 0.47μF/16V	CHD1CZ30F474
C7007	CHIP CERAMIC CAP. F Z 0.47μF/16V	CHD1CZ30F474
C7008	CHIP CERAMIC CAP.(1608) F Z 0.1μF/25V	CHD1EZ30F104
C7009	CHIP CERAMIC CAP.(1608) F Z 0.1μF/25V	CHD1EZ30F104
C7010	CHIP CERAMIC CAP.(1608) F Z 0.1μF/25V	CHD1EZ30F104
C7012	CHIP CERAMIC CAP.(1608) F Z 0.1μF/25V	CHD1EZ30F104
C7013	CHIP CERAMIC CAP.(1608) F Z 0.1μF/25V	CHD1EZ30F104
C7101	ELECTROLYTIC CAP. 220μF/10V M	CE1AMASDL221
C7102	CHIP CERAMIC CAP.(1608) CH J 1000pF/50V	CHD1JJ3CH102
C7109	CHIP CERAMIC CAP. F Z 2.2μF/10V	CHD1AZ30F225
C7110	CHIP CERAMIC CAP. F Z 2.2μF/10V	CHD1AZ30F225
C7111	ELECTROLYTIC CAP. 220μF/10V M	CE1AMASDL221
C7201	CHIP CERAMIC CAP. F Z 1μF/10V	CHD1AZ30F105
C7202	CHIP RES.(1608) 1/10W 0 Ω	RRXAZR5Z0000
C7203	ELECTROLYTIC CAP. 10μF/16V M H7	CE1CMAVSL100
C7204	CHIP CERAMIC CAP.(1608) B K 0.01μF/50V	CHD1JK30B103
C7301	CHIP CERAMIC CAP.(1608) CH J 100pF/50V	CHD1JJ3CH101
C7302	CHIP CERAMIC CAP.(1608) CH J 100pF/50V	CHD1JJ3CH101
C7303	CHIP CERAMIC CAP.(1608) F Z 0.1μF/25V	CHD1EZ30F104
C7304	ELECTROLYTIC CAP. 100μF/10V M	CE1AMASDL101
C7305	CHIP CERAMIC CAP.(1608) F Z 0.1μF/25V	CHD1EZ30F104
C7306	CHIP CERAMIC CAP.(1608) F Z 0.1μF/25V	CHD1EZ30F104
C7307	CHIP CERAMIC CAP. F Z 2.2μF/10V	CHD1AZ30F225
C7308	CHIP CERAMIC CAP. F Z 2.2μF/10V	CHD1AZ30F225
C7401	CHIP CERAMIC CAP. F Z 2.2μF/10V	CHD1AZ30F225
C7402	CHIP CERAMIC CAP. F Z 2.2μF/10V	CHD1AZ30F225
C7602	CHIP CERAMIC CAP. F Z 2.2μF/10V	CHD1AZ30F225
C7605	CHIP CERAMIC CAP. F Z 2.2μF/10V	CHD1AZ30F225
C7608	CHIP CERAMIC CAP. F Z 2.2μF/10V	CHD1AZ30F225
C7611	CHIP CERAMIC CAP. F Z 2.2μF/10V	CHD1AZ30F225
C7615	CHIP CERAMIC CAP. F Z 2.2μF/10V	CHD1AZ30F225
C7618	CHIP CERAMIC CAP. F Z 2.2μF/10V	CHD1AZ30F225
C7621	CHIP CERAMIC CAP. F Z 2.2μF/10V	CHD1AZ30F225
C7624	CHIP CERAMIC CAP. F Z 2.2μF/10V	CHD1AZ30F225
C7701	CHIP CERAMIC CAP.(1608) CH J 100pF/50V	CHD1JJ3CH101
C7702	CHIP CERAMIC CAP. F Z 0.47μF/16V	CHD1CZ30F474
C7705	CHIP CERAMIC CAP.(1608) CH J 100pF/50V	CHD1JJ3CH101
C7706	CHIP CERAMIC CAP. F Z 0.47μF/16V	CHD1CZ30F474
C7709	CHIP CERAMIC CAP.(1608) CH J 100pF/50V	CHD1JJ3CH101

Ref. No.	Description	Part No.
C7710	CHIP CERAMIC CAP. F Z 0.47μF/16V	CHD1CZ30F474
C7714	CHIP CERAMIC CAP.(1608) CH J 100pF/50V	CHD1JJ3CH101
C7715	CHIP CERAMIC CAP.(1608) B K 0.047μF/50V	CHD1JK30B473
C7718	CHIP CERAMIC CAP.(1608) CH J 100pF/50V	CHD1JJ3CH101
C7719	CHIP CERAMIC CAP. F Z 0.47μF/16V	CHD1CZ30F474
C7723	CHIP CERAMIC CAP.(1608) CH J 100pF/50V	CHD1JJ3CH101
C7724	CHIP CERAMIC CAP.(1608) B K 0.047μF/50V	CHD1JK30B473
C7729	CHIP CERAMIC CAP. CH J 39pF/50V	CHD1JJ3CH390
C7730	CHIP CERAMIC CAP. F Z 0.47μF/16V	CHD1CZ30F474
C7733	CHIP CERAMIC CAP. CH J 39pF/50V	CHD1JJ3CH390
C7734	CHIP CERAMIC CAP. F Z 0.47μF/16V	CHD1CZ30F474
C7738	CHIP CERAMIC CAP. CH J 39pF/50V	CHD1JJ3CH390
C7739	CHIP CERAMIC CAP. F Z 0.47μF/16V	CHD1CZ30F474
C7743	CHIP CERAMIC CAP. CH J 39pF/50V	CHD1JJ3CH390
C7744	CHIP CERAMIC CAP. F Z 0.47μF/16V	CHD1CZ30F474
C7747	CHIP CERAMIC CAP. CH J 39pF/50V	CHD1JJ3CH390
C7748	CHIP CERAMIC CAP. F Z 0.47μF/16V	CHD1CZ30F474
C7751	CHIP CERAMIC CAP. CH J 39pF/50V	CHD1JJ3CH390
C7752	CHIP CERAMIC CAP. F Z 0.47μF/16V	CHD1CZ30F474
C7801	ELECTROLYTIC CAP. 100μF/16V M	CE1CMASDL101
C7802	ELECTROLYTIC CAP. 100μF/16V M	CE1CMASDL101
CONNECTORS		
CN102	242 SERIES CONNECTOR 224202106W1	J322C06TG001
CN301	TWG CONNECTOR 23P TWG-P23P-A1	J3TWA23TG001
CN302	TWG CONNECTOR 23P TWG-P23P-A1	J3TWA23TG001
CN303	TWG CONNECTOR 23P TWG-P23P-A1	J3TWA23TG001
CN501	242 SERIES CONNECTOR 224202104W1	J322C04TG001
CN601	WIRE ASSEMBLY 004 2PIN / 100MM / AWG18	WX1A8AF0-004
CN801	PH CONNECTOR TOP 2P B2B-PH-K-S (LF)(SN)	J3PHC02JG029
CN802	PH CONNECTOR TOP 2P B2B-PH-K-S (LF)(SN)	J3PHC02JG029
DIODES		
D2	ZENER DIODE MTZJT-775.6B	QDTB0MTZJ5R6
D3	ZENER DIODE MTZJT-775.6B	QDTB0MTZJ5R6
D502	ZENER DIODE MTZJT-775.6A	QDTA0MTZJ5R6
D503	DIODE FR104-B	NDLZ000FR104
D504	ZENER DIODE MTZJT-7710B	QDTB00MTZJ10
D505	SWITCHING DIODE 1SS133(T-F7)	QDTZ001SS133
D506	SWITCHING DIODE 1SS133(T-F7)	QDTZ001SS133
D507	SWITCHING DIODE 1SS133(T-F7)	QDTZ001SS133
D508	SWITCHING DIODE 1SS133(T-F7)	QDTZ001SS133
D509	SWITCHING DIODE 1SS133(T-F7)	QDTZ001SS133
D510	SWITCHING DIODE 1SS133(T-F7)	QDTZ001SS133
D511	SWITCHING DIODE 1SS133(T-F7)	QDTZ001SS133
D513	SWITCHING DIODE 1SS133(T-F7)	QDTZ001SS133
D514	SWITCHING DIODE 1SS133(T-F7)	QDTZ001SS133
D602▲	ZENER DIODE MTZJT-7739B	QDTB00MTZJ39
D603	SWITCHING DIODE 1SS133(T-F7)	QDTZ001SS133
D604▲	ZENER DIODE MTZJT-7727B	QDTB00MTZJ27
D606	ZENER DIODE MTZJT-774.3B	QDTB0MTZJ4R3
D607	SWITCHING DIODE 1SS133(T-F7)	QDTZ001SS133
D631	ZENER DIODE MTZJT-775.6B	QDTB0MTZJ5R6
D632	SCHOTTKY BARRIER DIODE ERB81-004	AERB81004***
D633	DIODE FR154	NDLZ000FR154
D634	IC SHUNT REGULATOR KIA431-AT/P	NSZBA0TJY036
D635	ZENER DIODE MTZJT-7720B	QDTB00MTZJ20
D636	DIODE FR154	NDLZ000FR154
D637	DIODE FR154	NDLZ000FR154
D638	SCHOTTKY BARRIER DIODE ERC84-009	QDLZERC84009
D639	SCHOTTKY BARRIER DIODE ERC84-009	QDLZERC84009
D640	SCHOTTKY BARRIER DIODE SB340	NDQZ000SB340
D641	SWITCHING DIODE 1SS133(T-F7)	QDTZ001SS133

Ref. No.	Description	Part No.
D642	SWITCHING DIODE 1SS133(T-77)	QDTZ001SS133
D644	DIODE 1ZC43(Q)	QDLZ001ZC43Q
D645	SWITCHING DIODE 1SS133(T-77)	QDTZ001SS133
D646	SWITCHING DIODE 1SS133(T-77)	QDTZ001SS133
D647	SCHOTTKY BARRIER DIODE ERB81-004	AERB81004***
D648	IC SHUNT REGULATOR KIA431-AT/P	NSZBA0TJY036
D649	ZENER DIODE MTZJT-7733B	QDTB00MTZJ33
D650	ZENER DIODE MTZJT-776.2C	QDTC0MTZJ6R2
D651	DIODE FR104-B	NDLZ000FR104
D652	ZENER DIODE MTZJT-7724A	QDTA00MTZJ24
D654	DIODE FR154	NDLZ000FR154
D655	ZENER DIODE MTZJT-776.8C	QDTC0MTZJ6R8
D656	ZENER DIODE MTZJT-7716B	QDTB00MTZJ16
D657	DIODE FR154	NDLZ000FR154
D658	ZENER DIODE MTZJT-775.6C	QDTC0MTZJ5R6
D660	ZENER DIODE MTZJT-776.8B	QDTB0MTZJ6R8
D667	SCHOTTKY BARRIER DIODE SB140	NDWZ000SB140
D668	PCB JUMPER D0.6-P5.0	JW5.0T
D669	SCHOTTKY BARRIER DIODE ERA81-004Q	QDLZRA81004Q
D670	SWITCHING DIODE 1SS133(T-77)	QDTZ001SS133
D671	SWITCHING DIODE 1SS133(T-77)	QDTZ001SS133
D676	SWITCHING DIODE 1SS133(T-77)	QDTZ001SS133
D801	ZENER DIODE MTZJT-7710B	QDTB00MTZJ10
D802	ZENER DIODE MTZJT-775.6B	QDTB0MTZJ5R6
D804	SWITCHING DIODE 1SS133(T-77)	QDTZ001SS133
D805	SWITCHING DIODE 1SS133(T-77)	QDTZ001SS133
D811	ZENER DIODE MTZJT-7720B	QDTB00MTZJ20
D812	ZENER DIODE MTZJT-7720B	QDTB00MTZJ20
D813	ZENER DIODE MTZJT-7720B	QDTB00MTZJ20
D814	ZENER DIODE MTZJT-7720B	QDTB00MTZJ20
ICS		
IC603▲	PHOTO COUPLER LTV817MCF	NPECLTV817MF
IC637	IC LD1117V	NSZBA0SSS046
IC701	IC(AUDIO D/A) PCM1782DBQR	NSZBA0TTY192
IC702	IC OP AMP NJM4558M(Te1)-#ZZZB	QSZBA0TJR089
IC801	IC POWER AMP R2A15108SN	QSZBA0THT074
IC7001	IC VIDEO ANALOG INTERFACE R2A11011FP QFP 56PIN	QSZBA0RHT066
IC7301	IC SWITCHING TC4052BF(ELNF)	QSZBA0TTS162
COILS		
L1	CHOKE COIL 22μH-K	LLBD00PKV021
L801	COIL RADIAL LHLP10NB220M 22μH	LLF2200TU003
L802	COIL RADIAL LHLP10NB220M 22μH	LLF2200TU003
L803	COIL RADIAL LHLP10NB220M 22μH	LLF2200TU003
L804	COIL RADIAL LHLP10NB220M 22μH	LLF2200TU003
L7802	PCB JUMPER D0.6-P5.0	JW5.0T
L7803	PCB JUMPER D0.6-P5.0	JW5.0T
TRANSISTORS		
Q2	TRANSISTOR KTC3199-GR-AT/P	NQS4KTC3199P
Q3	TRANSISTOR KTC3199-GR-AT/P	NQS4KTC3199P
Q4	TRANSISTOR KTC3199-GR-AT/P	NQS4KTC3199P
Q5	TRANSISTOR KTC3199-GR-AT/P	NQS4KTC3199P
Q501	TRANSISTOR KTC3199-GR-AT/P	NQS4KTC3199P
Q502	TRANSISTOR KTC3199-GR-AT/P	NQS4KTC3199P
Q601▲	FET MOS 2SK3563(Q)	QFWZ2SK3563Q
Q602▲	TRANSISTOR 2SC2120-O(Te2 F T)	QQS02SC2120F
Q631	TRANSISTOR KTC3199-GR-AT/P	NQS4KTC3199P
Q632	TRANSISTOR KTA1267-GR-AT/P	NQS1KTA1267P
Q633	TRANSISTOR KTC3199-GR-AT/P	NQS4KTC3199P
Q634	TRANSISTOR KTC3199-GR-AT/P	NQS4KTC3199P
Q637	NPN TRANSISTOR POWER 2SC4881F HFE MAX320	QQWZ2SC4881F

Ref. No.	Description	Part No.
Q638	NPN TRANSISTOR POWER 2SC4881F HFE MAX320	QQWZ2SC4881F
Q639	TRANSISTOR KTA1267-GR-AT/P	NQS1KTA1267P
Q645	TRANSISTOR 2SD400(E)	QQUE002SD400
Q646	TRANSISTOR KTC3199-GR-AT/P	NQS4KTC3199P
Q650	TRANSISTOR KTC3199-GR-AT/P	NQS4KTC3199P
Q671	TRANSISTOR KTC3199-GR-AT/P	NQS4KTC3199P
Q801	TRANSISTOR 2SC2120-Y(Te2 F T)	QQSY2SC2120F
Q7201	TRANSISTOR KTC3199-GR-AT/P	NQS4KTC3199P
Q7301	TRANSISTOR KTC3199-GR-AT/P	NQS4KTC3199P
Q7302	TRANSISTOR KTC3199-GR-AT/P	NQS4KTC3199P
RESISTORS		
R1	CHIP RES.(1608) 1/10W 0 Ω	RRXAZR5Z0000
R2	CHIP RES.(1608) 1/10W 0 Ω	RRXAZR5Z0000
R5	CHIP RES. 1/10W J 1k Ω	RRXAJR5Z0102
R6	CHIP RES. 1/10W J 100 Ω	RRXAJR5Z0101
R7	CHIP RES. 1/10W J 150k Ω	RRXAJR5Z0154
R8	CHIP RES. 1/10W J 100k Ω	RRXAJR5Z0104
R11	CHIP RES. 1/10W J 220 Ω	RRXAJR5Z0221
R12	CHIP RES. 1/10W J 22k Ω	RRXAJR5Z0223
R13	CHIP RES. 1/10W J 22k Ω	RRXAJR5Z0223
R14	CHIP RES. 1/10W J 220k Ω	RRXAJR5Z0224
R16	CHIP RES. 1/10W J 750 Ω	RRXAJR5Z0751
R17	CHIP RES. 1/10W J 4.7k Ω	RRXAJR5Z0472
R18	CARBON RES. 1/4W J 4.7k Ω	RCX4JATZ0472
R19	CHIP RES. 1/10W J 560 Ω	RRXAJR5Z0561
R20	CHIP RES. 1/10W J 100 Ω	RRXAJR5Z0101
R21	CHIP RES. 1/10W J 4.7k Ω	RRXAJR5Z0472
R22	CHIP RES. 1/10W J 1.5k Ω	RRXAJR5Z0152
R24	CARBON RES. 1/4W J 1k Ω	RCX4JATZ0102
R25	CHIP RES. 1/10W J 10k Ω	RRXAJR5Z0103
R26	CHIP RES. 1/10W J 82 Ω	RRXAJR5Z0820
R301	CHIP RES.(1608) 1/10W 0 Ω	RRXAZR5Z0000
R302	CHIP RES.(1608) 1/10W 0 Ω	RRXAZR5Z0000
R303	CHIP RES.(1608) 1/10W 0 Ω	RRXAZR5Z0000
R501	PCB JUMPER D0.6-P5.0	JW5.0T
R502	CHIP RES. 1/10W F 7.50 k Ω	RRXAFR5H7501
R504	CHIP RES. 1/10W J 47k Ω	RRXAJR5Z0473
R505	CHIP RES. 1/10W J 22k Ω	RRXAJR5Z0223
R506	CHIP RES. 1/10W J 47k Ω	RRXAJR5Z0473
R507	CHIP RES. 1/10W J 22k Ω	RRXAJR5Z0223
R509	CHIP RES. 1/10W J 100k Ω	RRXAJR5Z0104
R510	CHIP RES.(1608) 1/10W 0 Ω	RRXAZR5Z0000
R512	CHIP RES.(1608) 1/10W 0 Ω	RRXAZR5Z0000
R514	PCB JUMPER D0.6-P5.0	JW5.0T
R516	CHIP RES.(1608) 1/10W 0 Ω	RRXAZR5Z0000
R517	PCB JUMPER D0.6-P5.0	JW5.0T
R519	CHIP RES.(1608) 1/10W 0 Ω	RRXAZR5Z0000
R521	PCB JUMPER D0.6-P5.0	JW5.0T
R523	CHIP RES. 1/10W J 51k Ω	RRXAJR5Z0513
R524	CHIP RES.(1608) 1/10W 0 Ω	RRXAZR5Z0000
R526	CHIP RES. 1/10W J 4.7k Ω	RRXAJR5Z0472
R527	CHIP RES.(1608) 1/10W 0 Ω	RRXAZR5Z0000
R601▲	METAL RES. 2W J 0.39 Ω	RN02JZPZ0R39
R603	PCB JUMPER D0.6-P5.0	JW5.0T
R604	CARBON RES. 1/4W J 390k Ω	RCX4JATZ0394
R605	CARBON RES. 1/4W J 390k Ω	RCX4JATZ0394
R606	CARBON RES. 1/4W J 390k Ω	RCX4JATZ0394
R607	CARBON RES. 1/4W J 390k Ω	RCX4JATZ0394
R609	CARBON RES. 1/4W J 5.6k Ω	RCX4JATZ0562
R610	CARBON RES. 1/4W J 180 Ω	RCX4JATZ0181
R611	CARBON RES. 1/4W J 820 Ω	RCX4JATZ0821
R612	CARBON RES. 1/4W J 180 Ω	RCX4JATZ0181

Ref. No.	Description	Part No.
R613	CARBON RES. 1/4W J 180 Ω	RCX4JATZ0181
R620	METAL OXIDE FILM RES. 1W J 1 Ω	RN011R0DP003
R622	CARBON RES. 1/4W J 1k Ω	RCX4JATZ0102
R631	METAL OXIDE FILM RES. 1W J 3.3 Ω	RN013R3DP003
R632	CHIP RES. 1/10W F 4.7k Ω	RRXAFR5H4701
R633	PCB JUMPER D0.6-P5.0	JW5.0T
R634	CARBON RES. 1/4W J 6.8k Ω	RCX4JATZ0682
R635	CARBON RES. 1/4W J 270 Ω	RCX4JATZ0271
R636	CHIP RES. 1/10W F 4.7k Ω	RRXAFR5H4701
R637	CARBON RES. 1/4W J 8.2k Ω	RCX4JATZ0822
R638	CHIP RES. 1/10W J 1.5k Ω	RRXAJR5Z0152
R639	CARBON RES. 1/4W J 100 Ω	RCX4JATZ0101
R640	CHIP RES. 1/10W F 2.2k Ω	RRXAFR5H2201
R641	CARBON RES. 1/4W J 1.2k Ω	RCX4JATZ0122
R642	CARBON RES. 1/4W J 2.7k Ω	RCX4JATZ0272
R643	PCB JUMPER D0.6-P15.0	JW15.0T
R644	PCB JUMPER D0.6-P5.0	JW5.0T
R645	CARBON RES. 1/4W J 12k Ω	RCX4JATZ0123
R646	CARBON RES. 1/4W J 12k Ω	RCX4JATZ0123
R647	CHIP RES. 1/10W J 22k Ω	RRXAJR5Z0223
R648	CHIP RES. 1/10W J 10k Ω	RRXAJR5Z0103
R649	METAL OXIDE FILM RES. 1W 470 Ω	RN01471DP003
R651	CARBON RES. 1/4W J 3.3k Ω	RCX4JATZ0332
R652	CARBON RES. 1/4W J 27k Ω	RCX4JATZ0273
R653	CARBON RES. 1/4W J 1.5k Ω	RCX4JATZ0152
R654	CARBON RES. 1/4W J 1.5k Ω	RCX4JATZ0152
R655	CHIP RES. 1/10W F 1.0k Ω	RRXAFR5H1001
R656	CARBON RES. 1/4W J 68 Ω	RCX4JATZ0680
R658	CHIP RES. 1/10W F 620 Ω	RRXAFR5H6200
R660	CHIP RES. 1/10W J 10k Ω	RRXAJR5Z0103
R662	CARBON RES. 1/4W J 4.7k Ω	RCX4JATZ0472
R663	METAL OXIDE FILM RES. 1W J 0.27 Ω	RN01R27DP003
R664	CHIP RES. 1/10W F 10k Ω	RRXAFR5H1002
R666	CARBON RES. 1/4W J 270 Ω	RCX4JATZ0271
R667	CARBON RES. 1/4W J 10 Ω	RCX4JATZ0100
R668	CHIP RES. 1/10W F 3.3k Ω	RRXAFR5H3301
R670	CARBON RES. 1/4W J 1k Ω	RCX4JATZ0102
R671	CHIP RES. 1/10W J 10k Ω	RRXAJR5Z0103
R672	CARBON RES. 1/4W J 1.8k Ω	RCX4JATZ0182
R673	CARBON RES. 1/4W J 1.8k Ω	RCX4JATZ0182
R674	CHIP RES. 1/10W J 10k Ω	RRXAJR5Z0103
R675	CARBON RES. 1/4W J 47k Ω	RCX4JATZ0473
R676	CHIP RES. 1/10W J 22k Ω	RRXAJR5Z0223
R677	CARBON RES. 1/4W J 22k Ω	RCX4JATZ0223
R684	CHIP RES. 1/10W J 56k Ω	RRXAJR5Z0563
R685	CARBON RES. 1/4W J 2.2k Ω	RCX4JATZ0222
R687	CARBON RES. 1/4W J 12k Ω	RCX4JATZ0123
R688	CARBON RES. 1/4W J 150 Ω	RCX4JATZ0151
R689	CARBON RES. 1/4W J 8.2k Ω	RCX4JATZ0822
R692	CARBON RES. 1/4W J 10k Ω	RCX4JATZ0103
R694	PCB JUMPER D0.6-P15.0	JW15.0T
R695	PCB JUMPER D0.6-P15.0	JW15.0T
R701	CHIP RES. 1/10W J 6.8k Ω	RRXAJR5Z0682
R702	CHIP RES. 1/10W J 47k Ω	RRXAJR5Z0473
R703	CHIP RES. 1/10W J 6.8k Ω	RRXAJR5Z0682
R704	CHIP RES. 1/10W J 47k Ω	RRXAJR5Z0473
R705	CHIP RES. 1/10W J 30k Ω	RRXAJR5Z0303
R706	CHIP RES.(1608) 1/10W 0 Ω	RRXAZR5Z0000
R710	CHIP RES. 1/10W J 33k Ω	RRXAJR5Z0333
R713	CHIP RES. 1/10W J 30k Ω	RRXAJR5Z0303
R714	CHIP RES.(1608) 1/10W 0 Ω	RRXAZR5Z0000
R717	CHIP RES. 1/10W J 10k Ω	RRXAJR5Z0103
R718	CHIP RES. 1/10W J 10k Ω	RRXAJR5Z0103

Ref. No.	Description	Part No.
R719	CHIP RES.(1608) 1/10W 0 Ω	RRXAZR5Z0000
R720	CHIP RES. 1/10W J 33k Ω	RRXAJR5Z0333
R802	CHIP RES. 1/10W J 4.7k Ω	RRXAJR5Z0472
R803	CARBON RES. 1/4W J 10 Ω	RCX4JATZ0100
R804	CARBON RES. 1/4W J 470 Ω	RCX4JATZ0471
R805	CARBON RES. 1/4W J 47k Ω	RCX4JATZ0473
R806	CHIP RES. 1/10W J 47k Ω	RRXAJR5Z0473
R807	CHIP RES. 1/10W J 560 Ω	RRXAJR5Z0561
R808	CHIP RES. 1/10W J 100 Ω	RRXAJR5Z0101
R809	CHIP RES.(1608) 1/10W 0 Ω	RRXAZR5Z0000
R811	CHIP RES. 1/10W J 560 Ω	RRXAJR5Z0561
R813	CHIP RES. 1/10W J 39k Ω	RRXAJR5Z0393
R814	CHIP RES. 1/10W J 18k Ω	RRXAJR5Z0183
R819	CHIP RES. 1/10W J 100 Ω	RRXAJR5Z0101
R821	CHIP RES.(1608) 1/10W 0 Ω	RRXAZR5Z0000
R7101	CHIP RES. 1/10W J 75 Ω	RRXAJR5Z0750
R7102	CHIP RES. 1/10W J 75 Ω	RRXAJR5Z0750
R7103	CHIP RES. 1/10W J 75 Ω	RRXAJR5Z0750
R7104	CARBON RES. 1/4W J 75 Ω	RCX4JATZ0750
R7105	CHIP RES.(1608) 1/10W 0 Ω	RRXAZR5Z0000
R7106	CHIP RES.(1608) 1/10W 0 Ω	RRXAZR5Z0000
R7111	CHIP RES. 1/10W J 75 Ω	RRXAJR5Z0750
R7112	CHIP RES. 1/10W J 75 Ω	RRXAJR5Z0750
R7201	CHIP RES. 1/10W J 47 Ω	RRXAJR5Z0470
R7202	CHIP RES. 1/10W J 24 Ω	RRXAJR5Z0240
R7204	CHIP RES. 1/10W J 100 Ω	RRXAJR5Z0101
R7207	CHIP RES. 1/10W J 56 Ω	RRXAJR5Z0560
R7301	CARBON RES. 1/4W J 10 Ω	RCX4JATZ0100
R7302	CHIP RES. 1/10W J 10k Ω	RRXAJR5Z0103
R7303	CHIP RES. 1/10W J 10k Ω	RRXAJR5Z0103
R7304	CHIP RES. 1/10W J 100 Ω	RRXAJR5Z0101
R7305	CHIP RES. 1/10W J 100 Ω	RRXAJR5Z0101
R7306	CHIP RES. 1/10W J 2.2k Ω	RRXAJR5Z0222
R7307	CHIP RES. 1/10W J 2.2k Ω	RRXAJR5Z0222
R7316	CHIP RES. 1/10W J 100k Ω	RRXAJR5Z0104
R7317	CHIP RES. 1/10W J 100k Ω	RRXAJR5Z0104
R7318	CHIP RES. 1/10W J 100k Ω	RRXAJR5Z0104
R7319	CHIP RES. 1/10W J 100k Ω	RRXAJR5Z0104
R7402	CHIP RES. 1/10W J 12k Ω	RRXAJR5Z0123
R7403	CHIP RES. 1/10W J 33k Ω	RRXAJR5Z0333
R7405	CHIP RES. 1/10W J 12k Ω	RRXAJR5Z0123
R7406	CHIP RES. 1/10W J 33k Ω	RRXAJR5Z0333
R7601	CHIP RES. 1/10W J 33k Ω	RRXAJR5Z0333
R7602	CHIP RES. 1/10W J 22k Ω	RRXAJR5Z0223
R7604	CHIP RES. 1/10W J 33k Ω	RRXAJR5Z0333
R7605	CHIP RES. 1/10W J 22k Ω	RRXAJR5Z0223
R7607	CHIP RES. 1/10W J 33k Ω	RRXAJR5Z0333
R7608	CHIP RES. 1/10W J 22k Ω	RRXAJR5Z0223
R7610	CHIP RES. 1/10W J 33k Ω	RRXAJR5Z0333
R7611	CHIP RES. 1/10W J 22k Ω	RRXAJR5Z0223
R7613	CHIP RES. 1/10W J 33k Ω	RRXAJR5Z0333
R7614	CHIP RES. 1/10W J 22k Ω	RRXAJR5Z0223
R7616	CHIP RES. 1/10W J 33k Ω	RRXAJR5Z0333
R7617	CHIP RES. 1/10W J 22k Ω	RRXAJR5Z0223
R7619	CHIP RES. 1/10W J 33k Ω	RRXAJR5Z0333
R7620	CHIP RES. 1/10W J 22k Ω	RRXAJR5Z0223
R7622	CHIP RES. 1/10W J 33k Ω	RRXAJR5Z0333
R7623	CHIP RES. 1/10W J 22k Ω	RRXAJR5Z0223
R7701	CHIP RES. 1/10W J 75 Ω	RRXAJR5Z0750
R7702	CHIP RES. 1/10W J 100 Ω	RRXAJR5Z0101
R7708	CHIP RES. 1/10W J 75 Ω	RRXAJR5Z0750
R7709	CHIP RES. 1/10W J 100 Ω	RRXAJR5Z0101
R7715	CHIP RES. 1/10W J 75 Ω	RRXAJR5Z0750

Ref. No.	Description	Part No.
R7716	CHIP RES. 1/10W J 100 Ω	RRXAJR5Z0101
R7723	CHIP RES. 1/10W J 75 Ω	RRXAJR5Z0750
R7724	CHIP RES. 1/10W J 100 Ω	RRXAJR5Z0101
R7730	CHIP RES. 1/10W J 75 Ω	RRXAJR5Z0750
R7731	CHIP RES. 1/10W J 100 Ω	RRXAJR5Z0101
R7738	CHIP RES. 1/10W J 75 Ω	RRXAJR5Z0750
R7739	CHIP RES. 1/10W J 100 Ω	RRXAJR5Z0101
R7747	CHIP RES. 1/10W J 75 Ω	RRXAJR5Z0750
R7748	CHIP RES. 1/10W J 100 Ω	RRXAJR5Z0101
R7755	CHIP RES. 1/10W J 75 Ω	RRXAJR5Z0750
R7756	CHIP RES. 1/10W J 100 Ω	RRXAJR5Z0101
R7763	CHIP RES. 1/10W J 75 Ω	RRXAJR5Z0750
R7764	CHIP RES. 1/10W J 100 Ω	RRXAJR5Z0101
R7771	CHIP RES. 1/10W J 75 Ω	RRXAJR5Z0750
R7772	CHIP RES. 1/10W J 100 Ω	RRXAJR5Z0101
R7779	CHIP RES. 1/10W J 75 Ω	RRXAJR5Z0750
R7780	CHIP RES. 1/10W J 100 Ω	RRXAJR5Z0101
R7787	CHIP RES. 1/10W J 75 Ω	RRXAJR5Z0750
R7788	CHIP RES. 1/10W J 100 Ω	RRXAJR5Z0101
MISCELLANEOUS		
B16	POW HEAT SINK A7120UH	1EM423993
B17	MODULE HEAT SINK PMC P7150UT	1EM423968
BC1	BEADS INDUCTOR FBR07HA121SB-00	LLBF00STU030
BC2	BEADS INDUCTOR FBR07HA121SB-00	LLBF00STU030
BC3	PCB JUMPER D0.6-P5.0	JW5.0T
BC4	CHIP INDUCTOR BK1608HS601-T	LLC601NTU017
BC601	BEADS INDUCTOR FBR07HA121SB-00	LLBF00STU030
BC701	BEADS INDUCTOR FBR07HA121SB-00	LLBF00STU030
BC702	BEADS INDUCTOR FBR07HA121SB-00	LLBF00STU030
BC801	PCB JUMPER D0.6-P5.0	JW5.0T
BC802	PCB JUMPER D0.6-P5.0	JW5.0T
BC803	PCB JUMPER D0.6-P5.0	JW5.0T
BC804	PCB JUMPER D0.6-P5.0	JW5.0T
BC7206	BEADS INDUCTOR FBR07HA121SB-00	LLBF00STU030
JK7701	Y/C JACK YKF51-5646N	JYEJ040JC001
JK7702	JACK SW RCA PCB S RCA-347HDT-02	JYRJ030YUQ01
JK7703	Y/C JACK YKF51-5646N	JYEJ040JC001
JK7704	JACK SW RCA PCB S RCA-347HDT-02	JYRJ030YUQ01
JK7705	JACK RCA PCB S RCA-228H(NI)-01	JXRJ020YUQ07
JK7711	JACK RCA PCB S 03 RCA-347HT-03	JXRJ030YUQ01
JK7712	JACK SW RCA PCB S RCA-228H(2)NI-01	JYRJ020YUQ02
JK7713	JACK RCA PCB S 03 RCA-347HT-03	JXRJ030YUQ01
JK7714	JACK SW RCA PCB S RCA-228H(2)NI-01	JYRJ020YUQ02
JK7715	JACK RCA PCB S ORANGE 01/RCA-101H(OR)	JXRJ010YUQ06
JS641	PCB JUMPER D0.6-P15.0	JW15.0T
JS651	PCB JUMPER D0.6-P5.0	JW5.0T
JS652	PCB JUMPER D0.6-P5.0	JW5.0T
L7	SCREW B-TIGHT D3X8 BIND HEAD+	GBJB3080
T601▲	TRANS POWER 8709	LTT2PC0KT032
TU1	TUNER UNIT UA023AF	UTUNATSSP006

FUNCTION CBA

Ref. No.	Description	Part No.
	FUNCTION CBA(MPS-3) Consists of the following:	-----
CAPACITORS		
C109	CHIP CERAMIC CAP.(1608) F Z 0.1μF/50V	CHD1JZ30F104
C110	CHIP CERAMIC CAP.(1608) F Z 0.1μF/50V	CHD1JZ30F104
DIODE		
D108	ZENER DIODE MTZJT-775.6B	QDTB0MTZJ5R6
RESISTORS		
R120	CARBON RES. 1/4W G 6.8k Ω	RCX4GATZ0682

Ref. No.	Description	Part No.
R121	CARBON RES. 1/4W G 4.7k Ω	RCX4GATZ0472
R122	CARBON RES. 1/4W G 2.7k Ω	RCX4GATZ0272
R123	CARBON RES. 1/4W G 2.2k Ω	RCX4GATZ0222
R124	CARBON RES. 1/4W G 1.5k Ω	RCX4GATZ0152
R125	CARBON RES. 1/4W J 220 Ω	RCX4JATZ0221
R126	CARBON RES. 1/4W G 1.5k Ω	RCX4GATZ0152
SWITCHES		
SW108	TACT SWITCH SKQSAB	SST0101AL038
SW109	TACT SWITCH SKQSAB	SST0101AL038
SW110	TACT SWITCH SKQSAB	SST0101AL038
SW111	TACT SWITCH SKQSAB	SST0101AL038
SW112	TACT SWITCH SKQSAB	SST0101AL038
SW113	TACT SWITCH SKQSAB	SST0101AL038
SW114	TACT SWITCH SKQSAB	SST0101AL038

IR SENSOR CBA

Ref. No.	Description	Part No.
	IR SENSOR CBA(MPS-4) Consists of the following:	-----
CAPACITORS		
C101	ELECTROLYTIC CAP. 47μF/16V M H7	CE1CMAVSL470
C107	CHIP CERAMIC CAP.(1608) F Z 0.1μF/50V	CHD1JZ30F104
DIODES		
D101	LED L-53HT	NP4Z000L53HT
D102	LED 333GT/E	NPHZ00333GTE
RESISTORS		
R101	CARBON RES. 1/4W J 100 Ω	RCX4JATZ0101
R102	CHIP RES. 1/10W J 3.3k Ω	RRXAJR5Z0332
R103	CHIP RES. 1/10W J 220 Ω	RRXAJR5Z0221
R104	CHIP RES. 1/10W J 220 Ω	RRXAJR5Z0221
R105	CHIP RES. 1/10W J 1k Ω	RRXAJR5Z0102
MISCELLANEOUS		
CL101	WIRE ASSEMBLY 002 6PIN / 350MM / AWG26	WX1A8AF0-002
CL102	WIRE ASSEMBLY 003 3PIN / 140MM / AWG26	WX1A8AF0-003
RCV101	PHOTO LINK MODULE KSM-712TH2E	USESJRSKK044

JUNCTION-A CBA

Ref. No.	Description	Part No.
	JUNCTION-A CBA(MPS-5) Consists of the following:	-----
CONNECTOR		
CN101	242 SERIES CONNECTOR TUC-P06X-B1 WHT ST	JCTUB06TG002

MUT CBA

Ref. No.	Description	Part No.
	MUT CBA Consists of the following	1FSA10452
	INVERTER CBA JUNCTION-B CBA	-----

INVERTER CBA

Ref. No.	Description	Part No.
	INVERTER CBA Consists of the following:	-----
CAPACITORS		
C1000	CHIP CERAMIC CAP.(1608) B K 1000pF/50V	CHD1JK30B102
C1001	CHIP CERAMIC CAP.(1608) B K 1μF/25V	CHD1EK30B105
C1002	CHIP CERAMIC CAP.(1608) B K 1000pF/50V	CHD1JK30B102
C1003	CHIP CERAMIC CAP.(1608) B K 1000pF/50V	CHD1JK30B102

Ref. No.	Description	Part No.
C1004	CHIP CERAMIC CAP.(1608) B K 0.01μF/50V	CHD1JK30B103
C1005	CHIP CERAMIC CAP.(1608) CH J 1000pF/50V	CHD1JJ3CH102
C1006	CHIP CERAMIC CAP.(1608) B K 0.047μF/50V	CHD1JK30B473
C1007	CHIP CERAMIC CAP. CH J 330pF/50V	CHD1JJ3CH331
C1008	CHIP CERAMIC CAP.(1608) B K 2.2μF/10V	CHD1AK30B225
C1009	CHIP CERAMIC CAP.(1608) B K 0.1μF/50V	CHD1JK30B104
C1010	CHIP CERAMIC CAP.(1608) B K 0.1μF/50V	CHD1JK30B104
C1011	CHIP CERAMIC CAP.(1608) B K 0.47μF/10V	CHD1AK30B474
C1012	CHIP CERAMIC CAP.(1608) B K 0.47μF/10V	CHD1AK30B474
C1014	CHIP CERAMIC CAP.(1608) B K 0.1μF/50V	CHD1JK30B104
C1015	ELECTROLYTIC CAP. 470μF/35V M	CE1GMZNDL471
C1016	CHIP CERAMIC CAP.(1608) B K 0.1μF/50V	CHD1JK30B104
C1017	CHIP CERAMIC CAP.(1608) B K 0.01μF/50V	CHD1JK30B103
C1018	CHIP CERAMIC CAP.(1608) B K 0.1μF/50V	CHD1JK30B104
C1019	CHIP CERAMIC CAP.(1608) B K 0.01μF/50V	CHD1JK30B103
C1020	CHIP CERAMIC CAP.(1608) B K 0.1μF/50V	CHD1JK30B104
C1021	CHIP CERAMIC CAP. F Z 1μF/10V	CHD1AZ30F105
C1022	CHIP CERAMIC CAP.(1608) CH J 1000pF/50V	CHD1JJ3CH102
C1023	CHIP CERAMIC CAP.(1608) CH J 1000pF/50V	CHD1JJ3CH102
C1032	ELECTROLYTIC CAP. 47μF/35V M	CE1GMASDL470
C1040	CHIP CERAMIC CAP.(1608) B K 1000pF/50V	CHD1JK30B102
C1044	CHIP CERAMIC CAP.(1608) B K 1μF/25V	CHD1EK30B105
C1046	CHIP CERAMIC CAP.(1608) B K 1μF/25V	CHD1EK30B105
C1061	CAP CERAMIC HV 15pF/3.15KV/SLJ	CCD3FJASL150
C1062	CHIP CERAMIC CAP. B K 1500pF/50V	CHD1JK30B152
C1063	CHIP CERAMIC CAP. B K 2200pF/50V	CHD1JK30B222
C1064	CAP CERAMIC HV 15pF/3.15KV/SLJ	CCD3FJASL150
C1065	CHIP CERAMIC CAP. B K 1500pF/50V	CHD1JK30B152
C1066	CHIP CERAMIC CAP. B K 2200pF/50V	CHD1JK30B222
C1067	CHIP CERAMIC CAP.(1608) B K 0.01μF/50V	CHD1JK30B103
C1101	CHIP CERAMIC CAP.(1608) B K 1000pF/50V	CHD1JK30B102
C1103	CHIP CERAMIC CAP.(1608) B K 1000pF/50V	CHD1JK30B102
C1104	CHIP CERAMIC CAP. CH J 220pF/50V	CHD1JJ3CH221
C1105	CHIP CERAMIC CAP. CH J 220pF/50V	CHD1JJ3CH221
C1106	CHIP CERAMIC CAP. CH J 220pF/50V	CHD1JJ3CH221
C1107	CHIP CERAMIC CAP. CH J 220pF/50V	CHD1JJ3CH221
C1111	CAP CERAMIC HV 15pF/3.15KV/SLJ	CCD3FJASL150
C1112	CHIP CERAMIC CAP. B K 1500pF/50V	CHD1JK30B152
C1113	CHIP CERAMIC CAP. B K 2200pF/50V	CHD1JK30B222
C1114	CAP CERAMIC HV 15pF/3.15KV/SLJ	CCD3FJASL150
C1115	CHIP CERAMIC CAP. B K 1500pF/50V	CHD1JK30B152
C1116	CHIP CERAMIC CAP. B K 2200pF/50V	CHD1JK30B222
C1117	CHIP CERAMIC CAP.(1608) B K 0.01μF/50V	CHD1JK30B103
C1161	CAP CERAMIC HV 15pF/3.15KV/SLJ	CCD3FJASL150
C1162	CHIP CERAMIC CAP. B K 1500pF/50V	CHD1JK30B152
C1163	CHIP CERAMIC CAP. B K 2200pF/50V	CHD1JK30B222
C1164	CAP CERAMIC HV 15pF/3.15KV/SLJ	CCD3FJASL150
C1165	CHIP CERAMIC CAP. B K 1500pF/50V	CHD1JK30B152
C1166	CHIP CERAMIC CAP. B K 2200pF/50V	CHD1JK30B222
C1167	CHIP CERAMIC CAP.(1608) B K 0.01μF/50V	CHD1JK30B103
C1211	CAP CERAMIC HV 15pF/3.15KV/SLJ	CCD3FJASL150
C1212	CHIP CERAMIC CAP. B K 1500pF/50V	CHD1JK30B152
C1213	CHIP CERAMIC CAP. B K 2200pF/50V	CHD1JK30B222
C1214	CAP CERAMIC HV 15pF/3.15KV/SLJ	CCD3FJASL150
C1215	CHIP CERAMIC CAP. B K 1500pF/50V	CHD1JK30B152
C1216	CHIP CERAMIC CAP. B K 2200pF/50V	CHD1JK30B222
C1217	CHIP CERAMIC CAP.(1608) B K 0.01μF/50V	CHD1JK30B103
C1261	CAP CERAMIC HV 15pF/3.15KV/SLJ	CCD3FJASL150
C1262	CHIP CERAMIC CAP. B K 1500pF/50V	CHD1JK30B152
C1263	CHIP CERAMIC CAP. B K 2200pF/50V	CHD1JK30B222
C1264	CAP CERAMIC HV 15pF/3.15KV/SLJ	CCD3FJASL150
C1265	CHIP CERAMIC CAP. B K 1500pF/50V	CHD1JK30B152
C1266	CHIP CERAMIC CAP. B K 2200pF/50V	CHD1JK30B222

Ref. No.	Description	Part No.
C1267	CHIP CERAMIC CAP.(1608) B K 0.01μF/50V	CHD1JK30B103
C1500	CHIP CERAMIC CAP.(1608) F Z 0.22μF/50V	CHD1JZ30F224
C1502	CHIP CERAMIC CAP.(1608) F Z 0.22μF/50V	CHD1JZ30F224
C1550	CHIP CERAMIC CAP.(1608) F Z 0.22μF/50V	CHD1JZ30F224
C1552	CHIP CERAMIC CAP.(1608) F Z 0.22μF/50V	CHD1JZ30F224
C1701	ELECTROLYTIC CAP. 10μF/50V M	CE1JMASDL100
C1901▲	METALIZED FILM CAP. 0.47μF/250V	CT2E474MS037
C1902▲	METALIZED FILM CAP. 0.47μF/250V	CT2E474MS037
C1910	CAP ELE LS 470μF/200V/M/85	CA2D471V8006
C1930	CERAMIC CAP. BN 1000pF/2KV	CCD3DKA0B102
C1931	POLYESTER FILM CAP. (PB FREE) 0.001μF/100V J	CA2A102DT018
C1932	POLYESTER FILM CAP. (PB FREE) 0.027μF/100V J	CA2A273DT018
C1933	POLYESTER FILM CAP. (PB FREE) 0.1μF/100V J	CA2A104DT018
C1941	CERAMIC CAP. B K 0.01μF/1KV	CCD3AKP0B103
C1970	POLYESTER FILM CAP. (PB FREE) 0.0022μF/100V J	CA2A222DT018
C1980	CHIP CERAMIC CAP. F Z 0.01μF/50V	CHD1JZ30F103
C1981	ELECTROLYTIC CAP. 0.47μF/50V M	CE1JMASDLR47
C1990	CERAMIC CAP. B K 3300pF/500V	CCD2JKS0B332
C1991▲	CAP ELE STD-85 4700μF/35V SL	CE1GMZNDL472
CONNECTORS		
CN1050	CONNECTOR PRINT OSU KW05-120-02-00	J30502KET001
CN1100	CONNECTOR PRINT OSU KW05-120-02-00	J30502KET001
CN1150	CONNECTOR PRINT OSU KW05-120-02-00	J30502KET001
CN1200	CONNECTOR PRINT OSU KW05-120-02-00	J30502KET001
CN1250	CONNECTOR PRINT OSU KW05-120-02-00	J30502KET001
CN1901	CONNECTOR B2P3-VH(LF)(SN)	J3VH020JG001
DIODES		
D1000	SWITCHING DIODE 1SS133(T-F7)	QDTZ001SS133
D1001	SWITCHING DIODE 1SS133(T-F7)	QDTZ001SS133
D1002	ZENER DIODE MTZJT-776.2B	QDTB0MTZJ6R2
D1003	ZENER DIODE MTZJT-776.2B	QDTB0MTZJ6R2
D1004	ZENER DIODE MTZJT-776.2B	QDTB0MTZJ6R2
D1005	ZENER DIODE MTZJT-776.2B	QDTB0MTZJ6R2
D1006	SWITCHING DIODE 1SS133(T-F7)	QDTZ001SS133
D1008	ZENER DIODE MTZJT-775.6B	QDTB0MTZJ5R6
D1021	SWITCHING DIODE 1SS133(T-F7)	QDTZ001SS133
D1042	ZENER DIODE MTZJT-7724B	QDTB00MTZJ24
D1043	SWITCHING DIODE 1SS133(T-F7)	QDTZ001SS133
D1045	ZENER DIODE MTZJT-7724B	QDTB00MTZJ24
D1046	SWITCHING DIODE 1SS133(T-F7)	QDTZ001SS133
D1060	SWITCHING DIODE 1SS133(T-F7)	QDTZ001SS133
D1061	SWITCHING DIODE 1SS133(T-F7)	QDTZ001SS133
D1062	SWITCHING DIODE 1SS133(T-F7)	QDTZ001SS133
D1063	SWITCHING DIODE 1SS133(T-F7)	QDTZ001SS133
D1064	SWITCHING DIODE 1SS133(T-F7)	QDTZ001SS133
D1065	SWITCHING DIODE 1SS133(T-F7)	QDTZ001SS133
D1066	SWITCHING DIODE 1SS133(T-F7)	QDTZ001SS133
D1067	SWITCHING DIODE 1SS133(T-F7)	QDTZ001SS133
D1068	SWITCHING DIODE 1SS133(T-F7)	QDTZ001SS133
D1110	SWITCHING DIODE 1SS133(T-F7)	QDTZ001SS133
D1111	SWITCHING DIODE 1SS133(T-F7)	QDTZ001SS133
D1112	SWITCHING DIODE 1SS133(T-F7)	QDTZ001SS133
D1113	SWITCHING DIODE 1SS133(T-F7)	QDTZ001SS133
D1114	SWITCHING DIODE 1SS133(T-F7)	QDTZ001SS133
D1115	SWITCHING DIODE 1SS133(T-F7)	QDTZ001SS133
D1116	SWITCHING DIODE 1SS133(T-F7)	QDTZ001SS133
D1117	SWITCHING DIODE 1SS133(T-F7)	QDTZ001SS133
D1118	SWITCHING DIODE 1SS133(T-F7)	QDTZ001SS133
D1160	SWITCHING DIODE 1SS133(T-F7)	QDTZ001SS133
D1161	SWITCHING DIODE 1SS133(T-F7)	QDTZ001SS133

Ref. No.	Description	Part No.
D1162	SWITCHING DIODE 1SS133(T-77)	QDTZ001SS133
D1163	SWITCHING DIODE 1SS133(T-77)	QDTZ001SS133
D1164	SWITCHING DIODE 1SS133(T-77)	QDTZ001SS133
D1165	SWITCHING DIODE 1SS133(T-77)	QDTZ001SS133
D1166	SWITCHING DIODE 1SS133(T-77)	QDTZ001SS133
D1167	SWITCHING DIODE 1SS133(T-77)	QDTZ001SS133
D1168	SWITCHING DIODE 1SS133(T-77)	QDTZ001SS133
D1210	SWITCHING DIODE 1SS133(T-77)	QDTZ001SS133
D1211	SWITCHING DIODE 1SS133(T-77)	QDTZ001SS133
D1212	SWITCHING DIODE 1SS133(T-77)	QDTZ001SS133
D1213	SWITCHING DIODE 1SS133(T-77)	QDTZ001SS133
D1214	SWITCHING DIODE 1SS133(T-77)	QDTZ001SS133
D1215	SWITCHING DIODE 1SS133(T-77)	QDTZ001SS133
D1216	SWITCHING DIODE 1SS133(T-77)	QDTZ001SS133
D1217	SWITCHING DIODE 1SS133(T-77)	QDTZ001SS133
D1218	SWITCHING DIODE 1SS133(T-77)	QDTZ001SS133
D1260	SWITCHING DIODE 1SS133(T-77)	QDTZ001SS133
D1261	SWITCHING DIODE 1SS133(T-77)	QDTZ001SS133
D1262	SWITCHING DIODE 1SS133(T-77)	QDTZ001SS133
D1263	SWITCHING DIODE 1SS133(T-77)	QDTZ001SS133
D1264	SWITCHING DIODE 1SS133(T-77)	QDTZ001SS133
D1265	SWITCHING DIODE 1SS133(T-77)	QDTZ001SS133
D1266	SWITCHING DIODE 1SS133(T-77)	QDTZ001SS133
D1267	SWITCHING DIODE 1SS133(T-77)	QDTZ001SS133
D1268	SWITCHING DIODE 1SS133(T-77)	QDTZ001SS133
D1501	SWITCHING DIODE 1SS133(T-77)	QDTZ001SS133
D1502	SWITCHING DIODE 1SS133(T-77)	QDTZ001SS133
D1503	SWITCHING DIODE 1SS133(T-77)	QDTZ001SS133
D1550	SWITCHING DIODE 1SS133(T-77)	QDTZ001SS133
D1551	SWITCHING DIODE 1SS133(T-77)	QDTZ001SS133
D1552	SWITCHING DIODE 1SS133(T-77)	QDTZ001SS133
D1553	SWITCHING DIODE 1SS133(T-77)	QDTZ001SS133
D1702	ZENER DIODE MTZJT-773.3B	QDTB0MTZJ3R3
D1901▲	DIODE 1N5406	NDLZ001N5406
D1902▲	DIODE 1N5406	NDLZ001N5406
D1903▲	DIODE 1N5406	NDLZ001N5406
D1904▲	DIODE 1N5406	NDLZ001N5406
D1930	ZENER DIODE MTZJT-7727B	QDTB00MTZJ27
D1931	ZENER DIODE MTZJT-775.6B	QDTB00MTZJ5R6
D1932	SWITCHING DIODE 1SS133(T-77)	QDTZ001SS133
D1933	SWITCHING DIODE 1SS133(T-77)	QDTZ001SS133
D1934	DIODE 1ZC36(Q)	QDLZ001ZC36Q
D1940	DIODE FAST RECOVERY FR157	NDLZ000FR157
D1970	ZENER DIODE MTZJT-775.6B	QDTB0MTZJ5R6
D1971	ZENER DIODE MTZJT-775.6B	QDTB0MTZJ5R6
D1980	ZENER DIODE MTZJT-7736B	QDTB00MTZJ36
D1981	PCB JUMPER D0.6-P5.0	JW5.0T
D1982	SWITCHING DIODE 1SS133(T-77)	QDTZ001SS133
D1990▲	DIODE SCHOTTKY FD867-15L	QDWZFD86715L
D1991▲	DIODE SCHOTTKY FD867-15L	QDWZFD86715L
D1992▲	DIODE SCHOTTKY FD867-15L	QDWZFD86715L
D1994	DIODE 1ZC36(Q)	QDLZ001ZC36Q
ICS		
IC1001	IC INVERTER CONTROLLER OZ9966SN-B1-0-TR/SSO	NSZBA0TTMC06
IC1500	IC BA10324AF-E2	QSZBA0TRM032
IC1550	IC BA10324AF-E2	QSZBA0TRM032
IC1930▲	PHOTO COUPLER LTV817MCF	NPECLTV817MF
IC1931▲	PHOTO COUPLER LTV817MCF	NPECLTV817MF
COILS		
L1901▲	FILTER LLBG00ZY2015	LLBG00ZY2015
L1902▲	FILTER LLBG00ZY2015	LLBG00ZY2015
TRANSISTORS		

Ref. No.	Description	Part No.
Q1002	TRANSISTOR KTC3199-GR-AT/P	NQS4KTC3199P
Q1020	TRANSISTOR KTA1267-GR-AT/P	NQS1KTA1267P
Q1100	FET POWER MOS SMD NP22N055SLE-E1-AZ	QF2ZNP22N055
Q1101	FET POWER MOS SMD NP22N055SLE-E1-AZ	QF2ZNP22N055
Q1102	FET POWER MOS SMD NP22N055SLE-E1-AZ	QF2ZNP22N055
Q1103	FET POWER MOS SMD NP22N055SLE-E1-AZ	QF2ZNP22N055
Q1930▲	FET MOS 2SK3561(Q) IDSS100UA	QFWZ2SK3561Q
Q1931	TRANSISTOR KTC3199-GR-AT/P	NQS4KTC3199P
Q1932	TRANSISTOR 2SC2120-Y(T E2 F T)	QQSY2SC2120F
Q1970	TRANSISTOR KTC3199-GR-AT/P	NQS4KTC3199P
Q1971	TRANSISTOR KTC3199-GR-AT/P	NQS4KTC3199P
Q1972	TRANSISTOR KTC3199-GR-AT/P	NQS4KTC3199P
RESISTORS		
R1000	CHIP RES. 1/10W J 20k Ω	RRXAJR5Z0203
R1001	CHIP RES. 1/10W J 10k Ω	RRXAJR5Z0103
R1002	CARBON RES. 1/4W J 5.1k Ω	RCX4JATZ0512
R1003	CHIP RES. 1/10W J 220k Ω	RRXAJR5Z0224
R1005	CHIP RES. 1/10W F 160 k Ω	RRXAFR5H1603
R1006	CHIP RES. 1/10W J 10k Ω	RRXAJR5Z0103
R1007	CHIP RES. 1/10W J 1M Ω	RRXAJR5Z0105
R1008	CHIP RES. 1/10W J 51k Ω	RRXAJR5Z0513
R1009	CHIP RES. 1/10W F 1M Ω	RRXAFR5H1004
R1010	CHIP RES. 1/10W F 120 k Ω	RRXAFR5H1203
R1011	CHIP RES. 1/10W F 130k Ω	RRXAFR5H1303
R1012	CHIP RES. 1/10W J 68k Ω	RRXAJR5Z0683
R1013	CHIP RES. 1/10W J 10k Ω	RRXAJR5Z0103
R1014	CARBON RES. 1/4W J 51k Ω	RCX4JATZ0513
R1015	CHIP RES.(1608) 1/10W F 5.1k Ω	RRXAFR5H0512
R1020	CHIP RES. 1/10W J 1M Ω	RRXAJR5Z0105
R1041	CHIP RES. 1/10W J 10k Ω	RRXAJR5Z0103
R1045	CHIP RES. 1/10W J 47k Ω	RRXAJR5Z0473
R1046	CARBON RES. 1/4W J 6.8k Ω	RCX4JATZ0682
R1047	CHIP RES. 1/10W J 1M Ω	RRXAJR5Z0105
R1048	CARBON RES. 1/4W J 1k Ω	RCX4JATZ0102
R1050	CHIP RES. 1/10W J 47k Ω	RRXAJR5Z0473
R1051	CARBON RES. 1/4W J 6.8k Ω	RCX4JATZ0682
R1052	CHIP RES. 1/10W J 1M Ω	RRXAJR5Z0105
R1053	CHIP RES. 1/10W J 1k Ω	RRXAJR5Z0102
R1060	CHIP RES. 1/10W J 100k Ω	RRXAJR5Z0104
R1061	CHIP RES. 1/10W J 20k Ω	RRXAJR5Z0203
R1062	CHIP RES. 1/10W F 750 Ω	RRXAFR5H7500
R1063	CHIP RES. 1/10W J 5.1k Ω	RRXAJR5Z0512
R1064	CHIP RES. 1/10W J 100k Ω	RRXAJR5Z0104
R1065	CHIP RES. 1/10W J 20k Ω	RRXAJR5Z0203
R1066	CHIP RES. 1/10W F 750 Ω	RRXAFR5H7500
R1067	CHIP RES. 1/10W J 5.1k Ω	RRXAJR5Z0512
R1068	CHIP RES. 1/10W F 6.8k Ω	RRXAFR5H6801
R1069	CHIP RES. 1/10W F 6.8k Ω	RRXAFR5H6801
R1070	CHIP RES. 1/10W J 1M Ω	RRXAJR5Z0105
R1071	CARBON RES. 1/4W J 1k Ω	RCX4JATZ0102
R1100	CHIP RES. 1/10W J 33 Ω	RRXAJR5Z0330
R1101	CHIP RES. 1/10W J 33 Ω	RRXAJR5Z0330
R1102	CHIP RES. 1/10W J 33 Ω	RRXAJR5Z0330
R1103	CHIP RES. 1/10W J 33 Ω	RRXAJR5Z0330
R1110	CHIP RES. 1/10W J 100k Ω	RRXAJR5Z0104
R1111	CHIP RES. 1/10W J 20k Ω	RRXAJR5Z0203
R1112	CHIP RES. 1/10W F 750 Ω	RRXAFR5H7500
R1113	CHIP RES. 1/10W J 5.1k Ω	RRXAJR5Z0512
R1114	CHIP RES. 1/10W J 100k Ω	RRXAJR5Z0104
R1115	CHIP RES. 1/10W J 20k Ω	RRXAJR5Z0203
R1116	CHIP RES. 1/10W F 750 Ω	RRXAFR5H7500
R1117	CHIP RES. 1/10W J 5.1k Ω	RRXAJR5Z0512

Ref. No.	Description	Part No.
R1118	CHIP RES. 1/10W F 6.8k Ω	RRXAFR5H6801
R1119	CHIP RES. 1/10W F 6.8k Ω	RRXAFR5H6801
R1120	CHIP RES. 1/10W J 1M Ω	RRXAJR5Z0105
R1121	CARBON RES. 1/4W J 1k Ω	RCX4JATZ0102
R1160	CHIP RES. 1/10W J 100k Ω	RRXAJR5Z0104
R1161	CHIP RES. 1/10W J 20k Ω	RRXAJR5Z0203
R1162	CHIP RES. 1/10W F 750 Ω	RRXAFR5H7500
R1163	CHIP RES. 1/10W J 5.1k Ω	RRXAJR5Z0512
R1164	CHIP RES. 1/10W J 100k Ω	RRXAJR5Z0104
R1165	CHIP RES. 1/10W J 20k Ω	RRXAJR5Z0203
R1166	CHIP RES. 1/10W F 750 Ω	RRXAFR5H7500
R1167	CHIP RES. 1/10W J 5.1k Ω	RRXAJR5Z0512
R1168	CHIP RES. 1/10W F 6.8k Ω	RRXAFR5H6801
R1169	CHIP RES. 1/10W F 6.8k Ω	RRXAFR5H6801
R1170	CHIP RES. 1/10W J 1M Ω	RRXAJR5Z0105
R1171	CARBON RES. 1/4W J 1k Ω	RCX4JATZ0102
R1210	CHIP RES. 1/10W J 100k Ω	RRXAJR5Z0104
R1211	CHIP RES. 1/10W J 20k Ω	RRXAJR5Z0203
R1212	CHIP RES. 1/10W F 750 Ω	RRXAFR5H7500
R1213	CHIP RES. 1/10W J 5.1k Ω	RRXAJR5Z0512
R1214	CHIP RES. 1/10W J 100k Ω	RRXAJR5Z0104
R1215	CHIP RES. 1/10W J 20k Ω	RRXAJR5Z0203
R1216	CHIP RES. 1/10W F 750 Ω	RRXAFR5H7500
R1217	CARBON RES. 1/4W J 5.1k Ω	RCX4JATZ0512
R1218	CHIP RES. 1/10W F 6.8k Ω	RRXAFR5H6801
R1219	CHIP RES. 1/10W F 6.8k Ω	RRXAFR5H6801
R1220	CHIP RES. 1/10W J 1M Ω	RRXAJR5Z0105
R1221	CARBON RES. 1/4W J 1k Ω	RCX4JATZ0102
R1260	CHIP RES. 1/10W J 100k Ω	RRXAJR5Z0104
R1261	CHIP RES. 1/10W J 20k Ω	RRXAJR5Z0203
R1262	CHIP RES. 1/10W F 750 Ω	RRXAFR5H7500
R1263	CARBON RES. 1/4W J 5.1k Ω	RCX4JATZ0512
R1264	CHIP RES. 1/10W J 100k Ω	RRXAJR5Z0104
R1265	CHIP RES. 1/10W J 20k Ω	RRXAJR5Z0203
R1266	CHIP RES. 1/10W F 750 Ω	RRXAFR5H7500
R1267	CARBON RES. 1/4W J 5.1k Ω	RCX4JATZ0512
R1268	CHIP RES. 1/10W F 6.8k Ω	RRXAFR5H6801
R1269	CHIP RES. 1/10W F 6.8k Ω	RRXAFR5H6801
R1270	CHIP RES. 1/10W J 1M Ω	RRXAJR5Z0105
R1271	CHIP RES. 1/10W J 1k Ω	RRXAJR5Z0102
R1500	CHIP RES. 1/10W F 47.0 k Ω	RRXAFR5H4702
R1501	CHIP RES. 1/10W F 1.0k Ω	RRXAFR5H1001
R1504	CHIP RES. 1/10W J 10k Ω	RRXAJR5Z0103
R1506	CHIP RES. 1/10W J 100k Ω	RRXAJR5Z0104
R1507	CHIP RES. 1/10W J 10k Ω	RRXAJR5Z0103
R1508	CHIP RES. 1/10W J 100k Ω	RRXAJR5Z0104
R1509	CHIP RES. 1/10W J 10k Ω	RRXAJR5Z0103
R1510	CHIP RES. 1/10W J 100k Ω	RRXAJR5Z0104
R1511	CHIP RES. 1/10W J 10k Ω	RRXAJR5Z0103
R1550	CHIP RES. 1/10W F 47.0 k Ω	RRXAFR5H4702
R1551	CHIP RES. 1/10W F 1.0k Ω	RRXAFR5H1001
R1554	CHIP RES. 1/10W J 100k Ω	RRXAJR5Z0104
R1555	CHIP RES. 1/10W J 10k Ω	RRXAJR5Z0103
R1556	CHIP RES. 1/10W J 100k Ω	RRXAJR5Z0104
R1557	CHIP RES. 1/10W J 10k Ω	RRXAJR5Z0103
R1558	CARBON RES. 1/4W J 100k Ω	RCX4JATZ0104
R1559	CHIP RES. 1/10W J 10k Ω	RRXAJR5Z0103
R1560	CHIP RES. 1/10W J 100k Ω	RRXAJR5Z0104
R1561	CHIP RES. 1/10W J 10k Ω	RRXAJR5Z0103
R1703	CHIP RES. 1/10W J 2.2k Ω	RRXAJR5Z0222
R1901▲	RES CARBON 1/2W J 1M Ω	RCX2105DP006
R1902▲	CEMENT RESISTOR 5W K 2.2 Ω	RW052R2PAK11
R1904▲	CEMENT RESISTOR 5W K 2.2 Ω	RW052R2PAK11

Ref. No.	Description	Part No.
R1930	CARBON RES. 1/4W J 47 Ω	RCX4JATZ0470
R1931	CARBON RES. 1/4W J 47k Ω	RCX4JATZ0473
R1932	CARBON RES. 1/4W J 120 Ω	RCX4JATZ0121
R1933	CARBON RES. 1/4W J 120 Ω	RCX4JATZ0121
R1934	CARBON RES. 1/4W J 1.5k Ω	RCX4JATZ0152
R1936	CARBON RES. 1/4W J 180 Ω	RCX4JATZ0181
R1937	METAL OXIDE FILM RES. 2W J 0.27 Ω	RN02R27ZU001
R1939	CARBON RES. 1/4W J 2.2k Ω	RCX4JATZ0222
R1940	CARBON RES. 1/4W J 470k Ω	RCX4JATZ0474
R1941	CARBON RES. 1/4W J 470k Ω	RCX4JATZ0474
R1942	CARBON RES. 1/4W J 180k Ω	RCX4JATZ0184
R1943	CARBON RES. 1/4W J 820k Ω	RCX4JATZ0824
R1944	CARBON RES. 1/4W J 820k Ω	RCX4JATZ0824
R1945	CARBON RES. 1/4W J 390k Ω	RCX4JATZ0394
R1946	METAL OXIDE FILM RES. 2W J 47k Ω	RN02473ZU001
R1947	METAL OXIDE FILM RES. 2W J 47k Ω	RN02473ZU001
R1948	METAL OXIDE FILM RES. 2W J 47k Ω	RN02473ZU001
R1949	CARBON RES. 1/4W J 120 Ω	RCX4JATZ0121
R1970	CARBON RES. 1/4W J 150 Ω	RCX4JATZ0151
R1971	CARBON RES. 1/4W J 3.9k Ω	RCX4JATZ0392
R1973	CARBON RES. 1/4W G 150 Ω	RCX4GATZ0151
R1974	CHIP RES. 1/10W F 5.6k Ω	RRXAFR5H5601
R1975	CHIP RES. 1/10W F 6.8k Ω	RRXAFR5H6801
R1976	CHIP RES. 1/10W F 6.8k Ω	RRXAFR5H6801
R1977	CHIP RES. 1/10W F 8.2k Ω	RRXAFR5H8201
R1980	CHIP RES. 1/10W J 100 Ω	RRXAJR5Z0101
R1981	CHIP RES. 1/10W J 1k Ω	RRXAJR5Z0102
R1983	CARBON RES. 1/4W J 1k Ω	RCX4JATZ0102
R1984	PCB JUMPER D0.6-P5.0	JW5.0T
R1985	CHIP RES. 1/10W J 22k Ω	RRXAJR5Z0223
R1986	CHIP RES. 1/10W J 3.3k Ω	RRXAJR5Z0332
R1987	CHIP RES. 1/10W J 2.2k Ω	RRXAJR5Z0222
MISCELLANEOUS		
AC1901▲	AC CORD LP-11W&PT218P-K90A&S	WAC0172LW020
B18	HEAT SINK PMP ASSEMBLY A8AF0UH	1EM425500
BC1001	PCB JUMPER D0.6-P5.0	JW5.0T
BC1931	BEADS INDUCTOR FBR07HA121SB-00	LLBF00STU030
BC1932	BEADS INDUCTOR FBR07HA121SB-00	LLBF00STU030
CL1000	WIRE ASSEMBLY 4PIN / 90MM / AWG26	WX1A8AF0-001
F1901▲	FUSE STC4A125V U/CT	PAGE20CW3402
FH1901	FUSE HOLDER MSF-015 LF (B110)	XH01Z00LY002
FH1902	FUSE HOLDER MSF-015 LF (B110)	XH01Z00LY002
L7	SCREW B-TIGHT D3X8 BIND HEAD+	GBJB3080
SA1901▲	SURGE ABSORBER 470V+-10PER	NVQZ10D471KB
T1050	TRANS INVERTER HVT-133	LTZ3PC0XB004
T1100	TRANS INVERTER HVT-133	LTZ3PC0XB004
T1150	TRANS INVERTER HVT-133	LTZ3PC0XB004
T1200	TRANS INVERTER HVT-133	LTZ3PC0XB004
T1250	TRANS INVERTER HVT-133	LTZ3PC0XB004
TM1901	EYELET TYPE D-1	0VM406868
TM1902	EYELET TYPE D-1	0VM406868
T1951▲	TRANS POWER 8708	LTT3PC0KT041

JUNCTION-B CBA

Ref. No.	Description	Part No.
	JUNCTION-B CBA Consists of the following:	-----
CONNECTOR		
CN1000	242 SERIES CONNECTOR TUC-P04X-B1 WHT ST	JCTUB04TG002

© 2008 Funai Electric Co., Ltd.

All rights reserved. No part of this manual may be reproduced, copied, transmitted, disseminated, transcribed, downloaded or stored in any storage medium, in any form or for any purpose without the express prior written consent of Funai. Furthermore, any unauthorized commercial distribution of this manual or any revision hereto is strictly prohibited.

Information in this document is subject to change without notice. Funai reserves the right to change the content herein without the obligation to notify any person or organization of such changes.

FUNAI with the  design is a registered trademark of Funai Electric Co., Ltd and may not be used in any way without the express written consent of Funai. All other trademarks used herein remain the exclusive property of their respective owners. Nothing contained in this manual should be construed as granting, by implication or otherwise, any license or right to use any of the trademarks displayed herein. Misuse of any trademarks or any other content in this manual is strictly prohibited. Funai shall aggressively enforce its intellectual property rights to the fullest extent of the law.

Free Manuals Download Website

<http://myh66.com>

<http://usermanuals.us>

<http://www.somanuals.com>

<http://www.4manuals.cc>

<http://www.manual-lib.com>

<http://www.404manual.com>

<http://www.luxmanual.com>

<http://aubethermostatmanual.com>

Golf course search by state

<http://golfingnear.com>

Email search by domain

<http://emailbydomain.com>

Auto manuals search

<http://auto.somanuals.com>

TV manuals search

<http://tv.somanuals.com>