

AL-M8250DN AL-M8150DN AL-M7150DN

# User's Guide



---

**Printing**

---

**Maintaining the Printer**

---

**Solving Problems**

---

## Contents

### **Guide to This Manual**

Introduction to the Manuals. . . . .	6
Searching for Information. . . . .	6
Printing Only the Pages You Need. . . . .	7
About This Manual. . . . .	7
Marks and Symbols. . . . .	7
Notes on Screenshots and Illustrations. . . . .	8
Operating System References. . . . .	8
Trademarks. . . . .	9
Copyright. . . . .	10

### **Important Instructions**

Important Safety Instructions. . . . .	12
Setting Up the Printer. . . . .	12
Finding the Place for the Printer. . . . .	13
Using the Printer. . . . .	15
Handling the Consumable Products and Maintenance Parts. . . . .	18
Safety Information. . . . .	18
Laser Safety Labels. . . . .	18
Internal Laser Radiation. . . . .	19
Ozone Safety. . . . .	19
Protecting Your Personal Information. . . . .	19

### **Part Names and Functions**

Front. . . . .	21
Inside. . . . .	22
Rear. . . . .	23

### **Guide to the Control Panel**

Control Panel. . . . .	26
Home Screen Configuration. . . . .	27
Guide to the Network Icon. . . . .	27
Menu Screen Configuration. . . . .	28
Entering Characters. . . . .	28
Viewing Animations. . . . .	29

### **Loading Paper**

Paper Handling Precautions. . . . .	31
Paper Size and Type Settings. . . . .	32
Loading Paper. . . . .	32
Loading Envelopes. . . . .	33

Paper Eject Setting. . . . .	33
Selecting Paper Eject Direction. . . . .	34
Ejecting Paper in Portrait or Landscape Alternately. . . . .	34

### **Printing**

Printing Documents. . . . .	36
Printing from a Computer - Windows. . . . .	36
Printing a Document Using the PostScript Printer Driver (Windows). . . . .	62
Printing from a Computer - Mac OS. . . . .	67
Printing from the PostScript Printer Driver on Mac OS. . . . .	80
Printing Documents from Smart Devices (iOS). . . . .	84
Printing Documents from Smart Devices (Android). . . . .	85
Printing on Envelopes. . . . .	86
Printing on Envelopes from a Computer (Windows). . . . .	86
Printing on Envelopes from a Computer (Mac OS). . . . .	87
Printing Web Pages. . . . .	87
Printing Web Pages from Smart Devices. . . . .	87
Printing Using a Cloud Service. . . . .	88
Registering to Epson Connect Service from the Control Panel. . . . .	88

### **Maintaining the Printer**

Checking the Consumables Status. . . . .	91
Cleaning the Paper Path when There are Paper Feeding Problems. . . . .	91
Cleaning the Pickup Rollers for the Paper Tray. . . . .	91
Cleaning the Pickup Rollers for the Paper Cassettes. . . . .	92
Cleaning Inside the Printer. . . . .	92
Cleaning the Printer. . . . .	96
Installing or Uninstalling Applications Separately. . . . .	96
Installing the Applications Separately. . . . .	96
Installing a PostScript Printer Driver. . . . .	99
Adding the Printer (for Mac OS Only). . . . .	100
Uninstalling Applications. . . . .	100
Updating Applications and Firmware. . . . .	102
Moving and Transporting the Printer. . . . .	104
Transporting the Printer for Short Distances. . . . .	104
Transporting the Printer. . . . .	105

Checking the Printer Status (Status Sheet Print). . . 106

## **Solving Problems**

Cannot Print. . . . .	108
Problem Solving. . . . .	108
The Application or Printer Driver do not Work Properly. . . . .	109
Cannot Connect to the Printer. . . . .	112
Paper Does Not Feed or Eject Correctly. . . . .	116
Cannot Operate the Printer as Expected. . . . .	120
Paper Gets Jammed. . . . .	123
Preventing Paper Jams. . . . .	124
A Message is Displayed on the LCD Screen. . . . .	125
It is Time to Replace Consumables. . . . .	126
Precautions when Handling Consumables. . . . .	126
It is Time to Replace the Toner Cartridge and the Waste Toner Collector. . . . .	127
Print Quality is Poor. . . . .	128
Printouts are Light, Dark, Faint, or Dirty. . . . .	128
The Position, Size, or Margins of the Printout Are Incorrect. . . . .	130
Printed Characters Are Incorrect or Garbled. . . . .	131
Cannot Read Barcodes. . . . .	131
Cannot Print Collated Pages. . . . .	132
Last Page is Printed on Opposite Side in 2-sided Printing. . . . .	132
The Font Cannot be Printed. . . . .	132
Printer Does Not Print Correctly While Using PostScript Printer Driver. . . . .	133
Cannot Solve Problem. . . . .	133

## **Adding or Replacing the Computer or Devices**

Connecting to a Printer that has been Connected to the Network. . . . .	135
Using a Network Printer from a Second Computer. . . . .	135
Using a Network Printer from a Smart Device. . . . .	136
Re-setting the Network Connection. . . . .	136
When Replacing the Wireless Router. . . . .	136
When Changing the Computer. . . . .	136
Changing the Connection Method to the Computer. . . . .	137
Checking the Network Connection Status. . . . .	137
Checking the Network Connection Status from the Control Panel. . . . .	138
Printing a Network Connection Report. . . . .	138
Printing a Network Status Sheet. . . . .	142

Checking the Network of the Computer (Windows only). . . . . 142

## **Using Optional Items**

List of Optional Items. . . . .	145
Precautions when Installing Optional Items. . . . .	147
Checking the Installed Optional Items. . . . .	147
Printer Stand. . . . .	148
Installing the Printer Stand to the Paper Cassette Unit. . . . .	148
Moving the Printer While the Printer Stand is Attached. . . . .	151
Printer Stand Specifications. . . . .	151
Paper Cassette Unit. . . . .	152
Installing the Paper Cassette Units to the Printer	152
Setting the Paper Cassette Unit in the Printer Driver. . . . .	155
Problems with the Paper Cassette Unit. . . . .	156
Paper Cassette Unit Specifications. . . . .	157
Face-up Tray. . . . .	157
Installing the Face up Tray. . . . .	157
Output to the Face up Tray Using Setting from the Printer Driver. . . . .	158
Face up Tray Specifications. . . . .	158
HDD (AL-M8250DN/AL-M8150DN Only). . . . .	158
Installing the HDD. . . . .	158
Setting the HDD in the Printer Driver. . . . .	163
Making Settings for Processing Saved Data. . . . .	164
Menu Options for Printing from a Computer (When the HDD is Installed). . . . .	165
Settings Menu List (When the HDD is Installed)	165
Ethernet Board (10/100/1000 Base-T, Ethernet) (AL-M8250DN/AL-M8150DN Only). . . . .	166
Function List when Using an Additional Network. . . . .	166
Installing an Ethernet Board. . . . .	167
Settings when Using an Additional Network. . . . .	169
Solving Problems when Using an Additional Network. . . . .	173
Menu Options for Network Settings (When Using an Additional Network). . . . .	173

## **Product Information**

Paper Information. . . . .	176
Available Paper and Capacities. . . . .	176
Unavailable Paper Types. . . . .	178
Consumable Products Information. . . . .	179
Consumable Products Code. . . . .	179

Software Information. . . . .	179
Software for Printing. . . . .	180
Software for Package Creation. . . . .	185
Software for Updating. . . . .	185
Settings Menu List. . . . .	186
General Settings. . . . .	186
Print Counter. . . . .	194
Replacement Parts. . . . .	194
Language. . . . .	194
Printer Status/Print. . . . .	194
Authentication Device Status. . . . .	195
Epson Open Platform Information. . . . .	195
Product Specifications. . . . .	195
Printing Features. . . . .	195
Using Port for the Printer. . . . .	197
Interface Specifications. . . . .	197
Network Specifications. . . . .	198
Supported Third Party Services. . . . .	199
PostScript Level 3 Compatibility. . . . .	199
Dimensions. . . . .	199
Electrical Specifications. . . . .	199
Environmental Specifications. . . . .	201
System Requirements. . . . .	201
Printer Adjust Menu. . . . .	201
Font Specifications. . . . .	204
Available Fonts for PostScript. . . . .	204
Available Fonts for PCL (URW). . . . .	206
List of Symbol Sets. . . . .	207
Epson BarCode Fonts (Windows Only). . . . .	210
Regulatory Information. . . . .	219
Standards and Approvals. . . . .	219
Restrictions on Copying. . . . .	219

## **Administrator Information**

Software Information for Administrators. . . . .	221
Application for Configuring Printer Operations (Web Config). . . . .	221
Application for Setting up the Device on a Network (EpsonNet Config). . . . .	222
Software for Managing Devices on the Network (Epson Device Admin). . . . .	223
Connecting the Printer to the Network. . . . .	223
Before Making Network Connection. . . . .	223
Connecting to the Network from the Control Panel. . . . .	225
Settings to Use the Printer. . . . .	227
Using the Print Functions. . . . .	227
Setting Up AirPrint. . . . .	235
Configuring a Mail Server. . . . .	235

Making Basic Operation Settings for the Printer	238
Problems when Making Settings. . . . .	241
Managing the Printer. . . . .	243
Introduction of Product Security Features. . . . .	243
Administrator Settings. . . . .	244
Restricting Available Features. . . . .	249
Disabling the External Interface. . . . .	251
Monitoring a Remote Printer. . . . .	252
Backing Up the Settings. . . . .	254
Advanced Security Settings. . . . .	255
Security Settings and Prevention of Danger. . . . .	255
Controlling Using Protocols. . . . .	256
Using a Digital Certificate. . . . .	261
SSL/TLS Communication with the Printer. . . . .	267
Encrypted Communication Using IPsec/IP Filtering. . . . .	268
Connecting the Printer to an IEEE802.1X Network. . . . .	279
Solving Problems for Advanced Security. . . . .	282
Epson Remote Services Information. . . . .	288

## **Where to Get Help**

Technical Support Web Site. . . . .	290
Contacting Epson Support. . . . .	290
Before Contacting Epson. . . . .	290
Help for Users in Taiwan. . . . .	290
Help for Users in Singapore. . . . .	291
Help for Users in Thailand. . . . .	291
Help for Users in Indonesia. . . . .	292
Help for Users in Hong Kong. . . . .	295
Help for Users in Malaysia. . . . .	295
Help for Users in the Philippines. . . . .	296

---

# Guide to This Manual

Introduction to the Manuals. . . . .	6
Searching for Information. . . . .	6
Printing Only the Pages You Need. . . . .	7
About This Manual. . . . .	7
Trademarks. . . . .	9
Copyright. . . . .	10

## Introduction to the Manuals

The following manuals are supplied with your Epson printer. As well as the manuals, check the various types of help information available from the printer itself or from the Epson software applications.

Setup Guide (paper manual)

Provides you with information on setting up the printer and installing the software.

User's Guide (digital manual)

This manual. This manual is available as PDF and Web manuals. Provides overall information and instructions on using the printer, on network settings when using the printer on a network, and on solving problems.

You can obtain the latest versions of the above manuals with the following methods.

Paper manual

Visit the Epson Europe support website at <http://www.epson.eu/support>, or the Epson worldwide support website at <http://support.epson.net/>.

Digital manual

To view the Web manual, visit the following website, enter the product name, and then go to **Support**.  
<http://epson.sn>

## Searching for Information

The PDF manual allows you to search for information you are looking for by keyword, or jump directly to specific sections using the bookmarks. This section explains how to use a PDF manual that has been opened in Adobe Acrobat Reader DC on your computer.

### Searching by keyword

Click **Edit > Advanced Search**. Enter the keyword (text) for information you want to find in the search window, and then click **Search**. Hits are displayed as a list. Click one of the displayed hits to jump to that page.

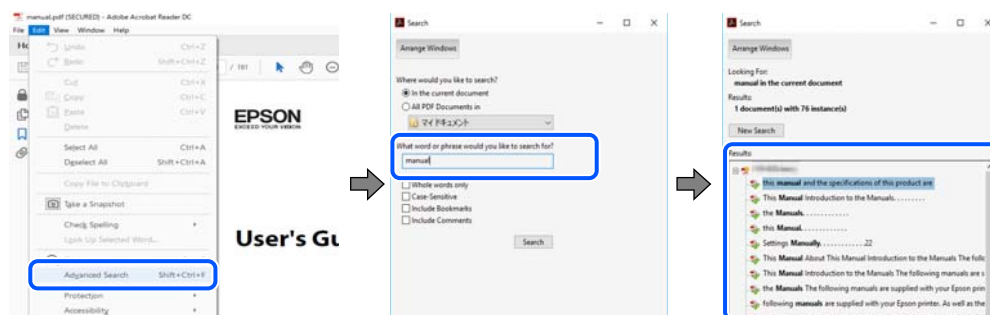

### Jumping directly from bookmarks

Click a title to jump to that page. Click + or > to view the lower level titles in that section. To return to the previous page, perform the following operation on your keyboard.

- Windows: Hold down **Alt.** and then press **←**.

- ❑ Mac OS: Hold down the command key, and then press ←.

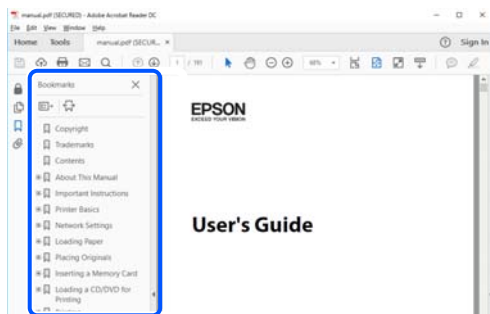

---

## Printing Only the Pages You Need

You can extract and print only the pages you need. Click **Print** in the **File** menu, and then specify the pages you want to print in **Pages in Pages to Print**.

- ❑ To specify a series of pages, enter a hyphen between the start page and the end page.

Example: 20-25

- ❑ To specify pages that are not in series, divide the pages with commas.

Example: 5, 10, 15

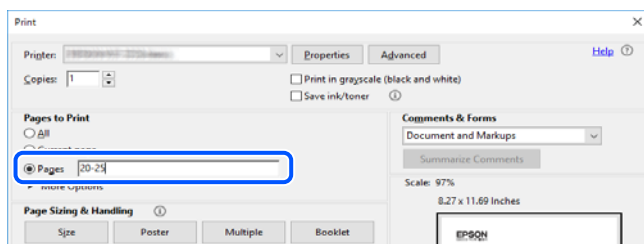

---

## About This Manual

This section explains the meaning of marks and symbols, notes on descriptions, and operating system reference information used in this manual.

### Marks and Symbols



**Warning:**

*Instructions that must be followed carefully to avoid serious bodily injury.*



**Caution:**

*Instructions that must be followed carefully to avoid bodily injury.*



**Important:**

*Instructions that must be observed to avoid damage to your equipment.*

**Note:**

*Provides complementary and reference information.*

**Related Information**

➔ Links to related sections.

## Notes on Screenshots and Illustrations

- Screenshots of the printer driver are from Windows 10 or macOS High Sierra. The content displayed on the screens varies depending on the model and situation.
- Illustrations used in this manual are examples only. Although there may be slight differences depending on the model, the method of operation is the same.
- Some of the menu items on the LCD screen vary depending on the model and settings.
- You can read the QR code using dedicated app.

## Operating System References

### Windows

In this manual, terms such as "Windows 10", "Windows 8.1", "Windows 8", "Windows 7", "Windows Vista", "Windows XP", "Windows Server 2019", "Windows Server 2016", "Windows Server 2012 R2", "Windows Server 2012", "Windows Server 2008 R2", "Windows Server 2008", "Windows Server 2003 R2", and "Windows Server 2003" refer to the following operating systems. Additionally, "Windows" is used to refer to all versions.

- Microsoft® Windows® 10 operating system
- Microsoft® Windows® 8.1 operating system
- Microsoft® Windows® 8 operating system
- Microsoft® Windows® 7 operating system
- Microsoft® Windows Vista® operating system
- Microsoft® Windows® XP operating system
- Microsoft® Windows® XP Professional x64 Edition operating system
- Microsoft® Windows Server® 2019 operating system
- Microsoft® Windows Server® 2016 operating system
- Microsoft® Windows Server® 2012 R2 operating system
- Microsoft® Windows Server® 2012 operating system
- Microsoft® Windows Server® 2008 R2 operating system
- Microsoft® Windows Server® 2008 operating system
- Microsoft® Windows Server® 2003 R2 operating system
- Microsoft® Windows Server® 2003 operating system



## Mac OS

In this manual, "Mac OS" is used to refer to Mac OS X v10.6.8 or later.

---

# Trademarks

- ❑ EPSON® is a registered trademark, and EPSON EXCEED YOUR VISION or EXCEED YOUR VISION is a trademark of Seiko Epson Corporation.
- ❑ EPSON ESC/Page and ESC/P are registered trademarks of Seiko Epson Corporation.
- ❑ QR Code is a registered trademark of DENSO WAVE INCORPORATED in Japan and other countries.
- ❑ The SuperSpeed USB Trident Logo is a registered trademark of USB Implementers Forum, Inc.
- ❑ Microsoft®, Windows®, Windows Server®, and Windows Vista® are registered trademarks of Microsoft Corporation.
- ❑ Apple, Mac, macOS, OS X, Bonjour, ColorSync, Safari, AirPrint, iPad, iPhone, iPod touch, iTunes, and TrueType are trademarks of Apple Inc., registered in the U.S. and other countries.
- ❑ Use of the Works with Apple badge means that an accessory has been designed to work specifically with the technology identified in the badge and has been certified by the developer to meet Apple performance standards.
- ❑ Chrome, Google Play, and Android are trademarks of Google LLC.
- ❑ Adobe, Acrobat, Photoshop, PostScript®3™, and Reader are either registered trademarks or trademarks of Adobe in the United States and/or other countries.
- ❑ Albertus, Arial, Coronet, Gill Sans, Joanna and Times New Roman are trademarks of The Monotype Corporation registered in the United States Patent and Trademark Office and may be registered in certain jurisdictions.
- ❑ ITC Avant Garde Gothic, ITC Bookman, Lubalin Graph, Mona Lisa, ITC Symbol, Zapf Chancery and Zapf Dingbats are trademarks of International Typeface Corporation registered in the U.S. Patent and Trademark Office and may be registered in certain other jurisdictions.
- ❑ Clarendon, Eurostile and New Century Schoolbook are trademarks of Linotype GmbH registered in the U.S. Patent and Trademark Office and may be registered in certain other jurisdictions.
- ❑ Wingdings is a registered trademark of Microsoft Corporation in the United States and other countries.
- ❑ CG Omega, CG Times, Garamond Antiqua, Garamond Halbfett, Garamond Kursiv, Garamond Halbfett Kursiv are trademarks of Monotype Imaging, Inc. and may be registered in certain jurisdictions.
- ❑ Antique Olive is a trademark of M. Olive.
- ❑ Marigold and Oxford are trademarks of AlphaOmega Typography.
- ❑ Helvetica, Optima, Palatino, Times and Univers are trademarks of Linotype Corp. registered in the U.S. Patent and Trademark Office and may be registered in certain other jurisdictions in the name of Linotype Corp. or its licensee Linotype GmbH.
- ❑ ITC Avant Garde Gothic, Bookman, Zapf Chancery and Zapf Dingbats are trademarks of International Typeface Corporation registered in the United States Patent and Trademark Office and may be registered in certain jurisdictions.
- ❑ PCL is the registered trademark of Hewlett-Packard Company.
- ❑ Firefox is a trademark of the Mozilla Foundation in the U.S. and other countries.
- ❑ HP and HP LaserJet are registered trademarks of the Hewlett-Packard Company.

- ❑ Mopria® and the Mopria® Logo are registered and/or unregistered trademarks and service marks of Mopria Alliance, Inc. in the United States and other countries. Unauthorized use is strictly prohibited.
- ❑ General Notice: Other product names used herein are for identification purposes only and may be trademarks of their respective owners. Epson disclaims any and all rights in those marks.

---

## Copyright

No part of this publication may be reproduced, stored in a retrieval system, or transmitted in any form or by any means, electronic, mechanical, photocopying, recording, or otherwise, without the prior written permission of Seiko Epson Corporation. No patent liability is assumed with respect to the use of the information contained herein. Neither is any liability assumed for damages resulting from the use of the information herein. The information contained herein is designed only for use with this Epson product. Epson is not responsible for any use of this information as applied to other products.

Neither Seiko Epson Corporation nor its affiliates shall be liable to the purchaser of this product or third parties for damages, losses, costs, or expenses incurred by the purchaser or third parties as a result of accident, misuse, or abuse of this product or unauthorized modifications, repairs, or alterations to this product, or (excluding the U.S.) failure to strictly comply with Seiko Epson Corporation's operating and maintenance instructions.

Seiko Epson Corporation and its affiliates shall not be liable for any damages or problems arising from the use of any options or any consumable products other than those designated as Original Epson Products or Epson Approved Products by Seiko Epson Corporation.

Seiko Epson Corporation shall not be held liable for any damage resulting from electromagnetic interference that occurs from the use of any interface cables other than those designated as Epson Approved Products by Seiko Epson Corporation.

© 2020 Seiko Epson Corporation

The contents of this manual and the specifications of this product are subject to change without notice.

---

# Important Instructions

Important Safety Instructions. . . . .	12
Safety Information. . . . .	18
Protecting Your Personal Information. . . . .	19

## Important Safety Instructions

### Setting Up the Printer

- ❑ Because the printer is heavy, one person should not lift or carry it. Two people should carry the printer, lifting it by the correct positions as shown below. Do not touch the projections on the bottom of the printer that are for connecting an optional paper cassette.

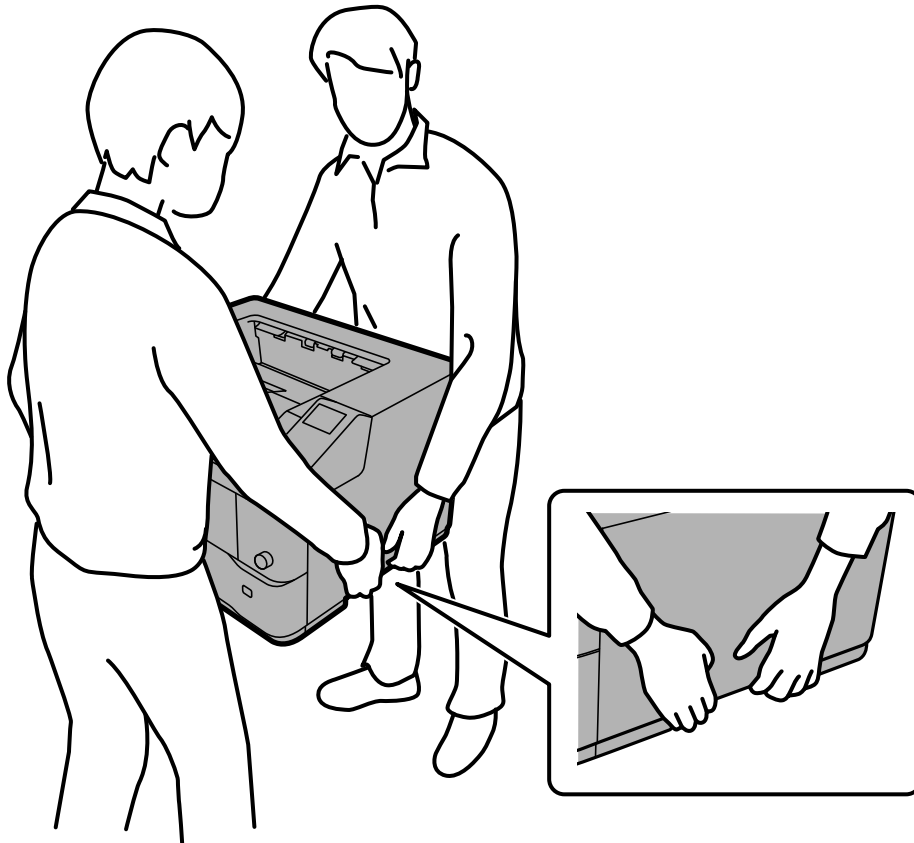

- ❑ When moving the printer, always keep it horizontal.
- ❑ If you are unable to insert the AC plug into the electrical outlet, contact an electrician.
- ❑ Do not connect to an uninterruptible power source. If you connect to one, it may cause malfunctions or damage.
- ❑ Be sure the AC power cord meets the relevant local safety standards. Use only the power cord that comes with this product. Use of another cord may result in fire or electric shock. This product's power cord is for use with this product only. Use with other equipment may result in fire or electric shock.
- ❑ If damage occurs to the plug, replace the cord set or consult a qualified electrician. If there are fuses in the plug, make sure you replace them with fuses of the correct size and rating.
- ❑ Use a grounded outlet that matches the printer's power plug. Do not use an adapter plug.
- ❑ Avoid using an electrical outlet that is controlled by wall switches or automatic timers. Accidental disruption of power can erase valuable information in your computer's and printer's memory.
- ❑ Make sure that there is no dust on the socket.
- ❑ Be sure to insert the plug completely into the electrical outlet.

- Do not handle the plug with wet hands.
- Unplug this printer from the wall outlet and refer servicing to a qualified service representative under the following conditions:

A.	When the power cord or plug is damaged or frayed.
B.	If liquid has been spilled into it.
C.	If it has been exposed to rain or water.
D.	If it does not operate normally when the operating instructions are followed. Adjust only those controls that are covered by the operating instructions since improper adjustment of other controls may result in damage and will often require extensive work by a qualified technician to restore the product to normal operation.
E.	If it has been dropped or the cabinet has been damaged.
F.	If it exhibits a distinct change in performance, indicating a need for service.

- Avoid sharing outlets with other appliances.
- Connect all equipment to properly grounded power outlets. Avoid using outlets on the same circuit as photocopiers or air control systems that regularly switch on and off.
- Connect your printer to an electrical outlet that meets the power requirements of this printer. Your printer's power requirements are indicated on a label attached to the printer. If you are not sure of the power supply specifications in your area, contact your local power company or consult your dealer.
- If you use an extension cord, make sure that the total of the ampere ratings on the products plugged into the extension cord does not exceed the extension cord ampere rating.
- When connecting this product to a computer or other device with a cable, ensure the correct orientation of the connectors. Each connector has only one correct orientation. Inserting a connector in the wrong orientation may damage both devices connected by the cable.
- Use only optional products, such as the paper cassette units and the printer stand, produced specifically for this product. Using options produced for other products may cause the product to fall over and injure someone.
- When lifting the printer onto the optional printer stand, be sure to lock the stand's casters.

## Finding the Place for the Printer

When relocating the printer, always choose a location that has adequate space for easy operation and maintenance. Use the following illustration as a guide for the amount of space required around the printer to ensure smooth operation.

**Note:**

Figures are rounded off to the nearest whole number.

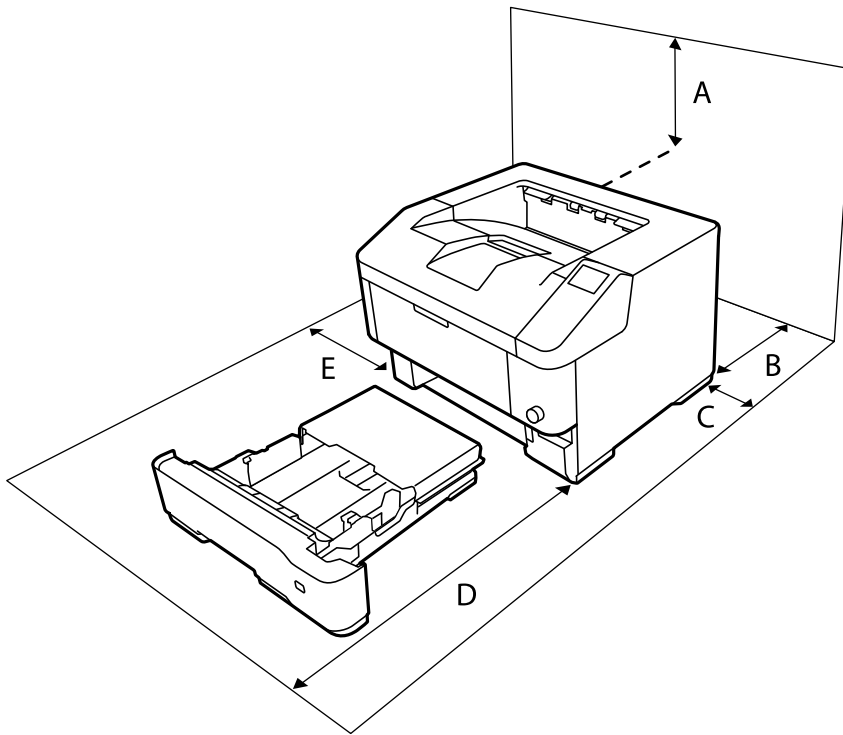

A	400 mm
B	200 mm *
C	100 mm
D	600 mm
E	300 mm

\* 500 mm when face-up tray is installed.

In addition to space considerations, always heed the following precautions when finding a place to locate the printer:

- Place the printer near an electrical outlet where you can easily plug in and unplug the power cord.
- Do not put your printer where the cord will be stepped on.
- Do not use printer in a damp environment.
- Avoid locations that are subject to direct sunlight, excessive heat, moisture, oil vapor, or dust.
- Avoid locations that are subject to the air coming directly from an air conditioner.
- Do not place the printer on an unstable surface.
- Slots and openings in the cabinet and the back or bottom are provided for ventilation. Do not block or cover them. Do not put the printer on a bed, sofa, rug, or other similar surface or in a built-in installation unless proper ventilation is provided.
- Keep the entire computer and printer system away from potential sources of interference, such as loudspeakers or the base units of cordless telephones.

- ❑ Leave adequate room around the printer to allow for sufficient ventilation.

## Using the Printer

- ❑ Some of the symbols used on your printer are to ensure safety and proper use of the printer. Visit the following web site to learn the meaning of the symbols:

<http://support.epson.net/symbols>

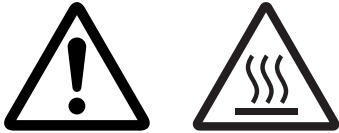

### CAUTION: Hot surface

Be careful not to touch the fuser, which is marked with a caution label, or the surrounding areas. If the printer has been in use, the fuser and the surrounding areas may be very hot. If you must touch one of these areas, wait 40 minutes to allow the heat to subside before doing so.



### Do not touch the Sharp edges

Be careful of the sharp edges. Do not touch the sharp edges. It may hurt your fingers, etc.

- ❑ Be careful not to touch the fuser unit, which is marked with a caution label, or the surrounding areas. If the printer has been in use, the fuser unit and the surrounding areas may be very hot. If you must touch one of these areas, turn off the printer and wait for at least 40 minutes to allow the heat to disperse before doing so.

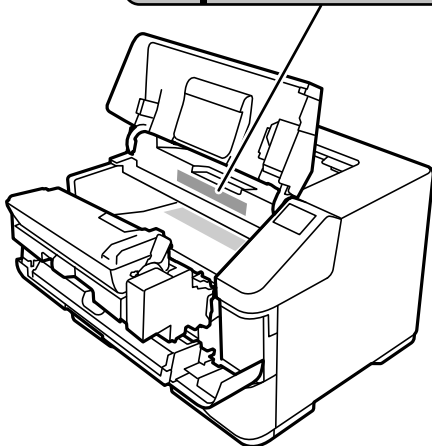

- ❑ Be careful not to touch anywhere near the transfer roller, which is marked with a caution label, or the surrounding areas. There are sharp edges around the transfer roller that could injure your fingers. Be careful not to touch these edges.

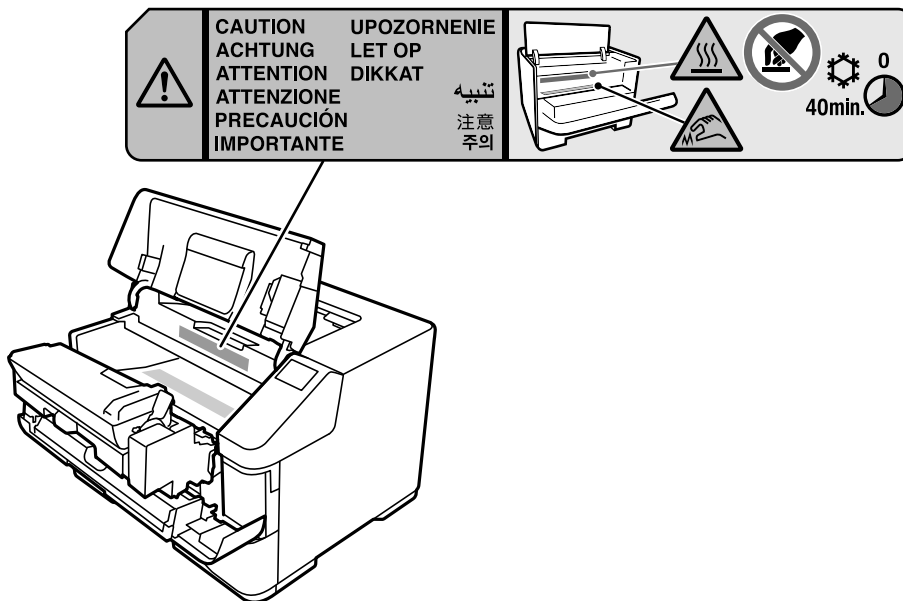

- ❑ Be careful not to touch the fuser unit cover, which is marked with a caution label, or the surrounding areas. If the printer has been in use, the fuser unit cover and the surrounding areas may be very hot. If you must touch one of these areas, turn off the printer and wait for at least 40 minutes to allow the heat to disperse before doing so.

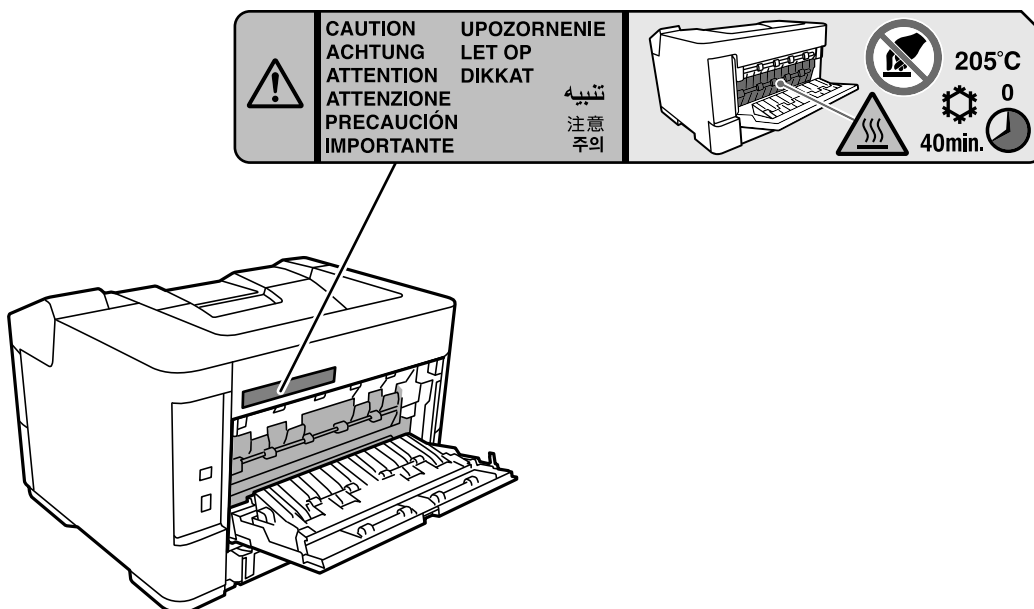



- ❑ The connector at the bottom of the printer has sharp edges that could injure your fingers. Be careful not to touch these edges.

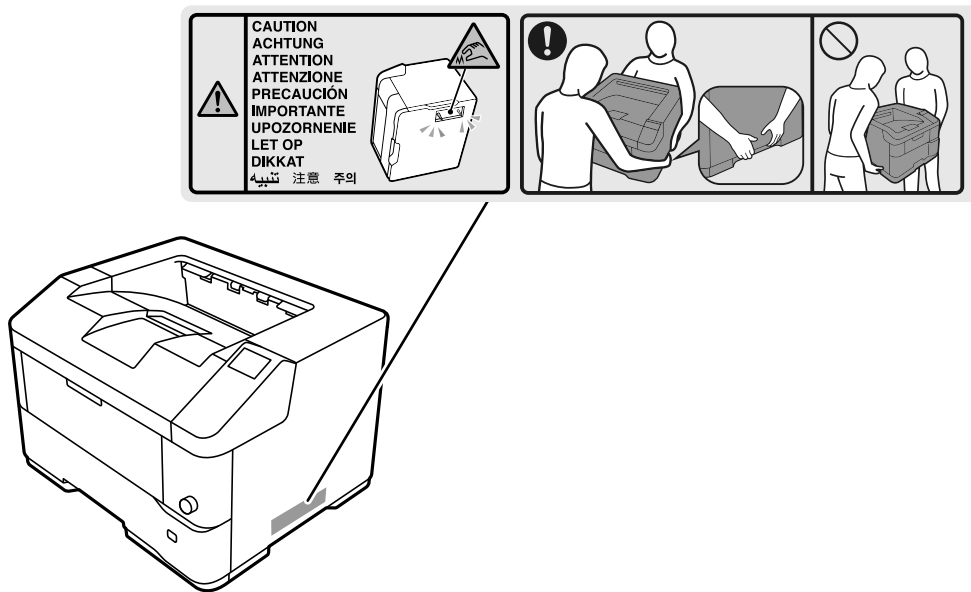

- ❑ Do not insert your hand deep into the fuser unit as some components are sharp and may cause injury.
- ❑ Never push objects of any kind through cabinet slots as they may touch dangerous voltage points or short out parts that could result in a risk of fire or electric shock.
- ❑ Do not sit or lean on the printer. Do not put heavy objects on the printer.
- ❑ When optional paper cassettes are installed, do not open two or more paper cassettes at the same time. The open can unbalance the printer, and if any pressure is placed on the back of it, it may fall over and cause an injury.
- ❑ Do not use any kind of combustible gases in or around the printer.
- ❑ Never force the printer's components into place. Although the printer is designed to be sturdy, rough handling can damage it.
- ❑ Do not leave jammed paper inside the printer. This can cause the printer to overheat.
- ❑ Never spill liquid of any kind on the printer.
- ❑ Adjust only those controls that are covered by the operating instructions. Improper adjustment of other controls may result in damage and may require repair by a qualified service representative.
- ❑ Do not turn off the printer:
  - After turning on the printer, wait until the home screen is displayed on the LCD screen.
  - While the Data light is on or flashing.
  - While printing.
  - While firmware is updating.
- ❑ Avoid touching the components inside the printer unless instructed to do so in this guide.
- ❑ Follow all warnings and instructions marked on the printer.
- ❑ Except as specifically explained in the printer's documentation, do not attempt to service this product yourself.
- ❑ Periodically disconnect the plug from the electrical outlet and clean the blades.
- ❑ Do not disconnect the plug while the printer is on.
- ❑ If the printer will not be used for a long time, disconnect the plug from the electrical outlet.

- Unplug this printer from the wall outlet before cleaning.
- Use a well-wrung cloth for cleaning and do not use liquid or aerosol cleaners.

## Handling the Consumable Products and Maintenance Parts

- Do not burn used consumable products and maintenance parts because they might explode and injure someone. Dispose of them according to local regulations.
- Be sure to keep consumable products and maintenance parts out of the reach of children.
- When handling a toner cartridge, always place it on a clean, smooth surface.
- Do not attempt to modify or take it apart consumable products and maintenance parts.
- Do not touch the toner. Always keep toner away from your eyes. If toner gets on your skin or clothes, wash it off with soap and water immediately.
- If toner is spilled, use a broom and dustpan or a damp cloth with soap and water to clean it up. Because the fine particles can cause a fire or explosion if they come into contact with a spark, do not use a vacuum cleaner.
- Wait at least one hour before using a toner cartridge after moving it from a cool to a warm environment to prevent damage from condensation.
- To get the best print quality, do not store the toner cartridge in an area subject to direct sunlight, dust, salty air, or corrosive gases (such as ammonia). Avoid locations subject to extreme or rapid changes in temperature or humidity.
- Do not touch the transfer roller to avoid damaging it.
- Do not let the paper's edge slide across your skin because the edge of the paper may cut you.

---

## Safety Information

### Laser Safety Labels



**Warning:**

*The performance of procedures and adjustments other than those specified in the printer's documentation may result in hazardous radiation exposure. Your printer is a Class 1 laser product as defined in the IEC60825 specifications. The label similar to the one shown below is attached to the back of the printer in countries where required.*



## Internal Laser Radiation

There is a Class III b Laser Diode Assembly that has an invisible laser beam inside the printer head unit. The printer head unit is NOT A SERVICE ITEM, therefore, the printer head unit should not be opened under any circumstances. An additional laser warning label is affixed to the inside of the printer.

## Ozone Safety

### Ozone Emission

Ozone gas is generated by laser printers as a by-product of the printing process. Ozone is produced only when the printer is printing.

### Ozone Exposure Limit

The Epson laser printer generates less than 1.5 mg/h of continuous printing.

### Minimize the Risk

To minimize the risk of exposure to ozone, you should avoid the following conditions:

- Use of multiple laser printers in a confined area
- Operation in conditions of extremely low humidity
- Poor room ventilation
- Long, continuous printing together with any of the above

### Printer Location

The printer should be located so that the exhaust gases and heat generated are:

- Not blown directly into the user's face
- Vented directly out of the building whenever possible

---

## Protecting Your Personal Information

When you give the printer to someone else or dispose of it, erase all the personal information stored in the printer's memory by selecting **Settings > General Settings > System Administration > Restore Default Settings > All Settings** on the control panel. Also, make sure you delete the printer's internal memory data by selecting **Settings > General Settings > System Administration > Clear Internal Memory Data** on the control panel.

---

# Part Names and Functions

Front. ....	21
Inside. ....	22
Rear. ....	23

## Front

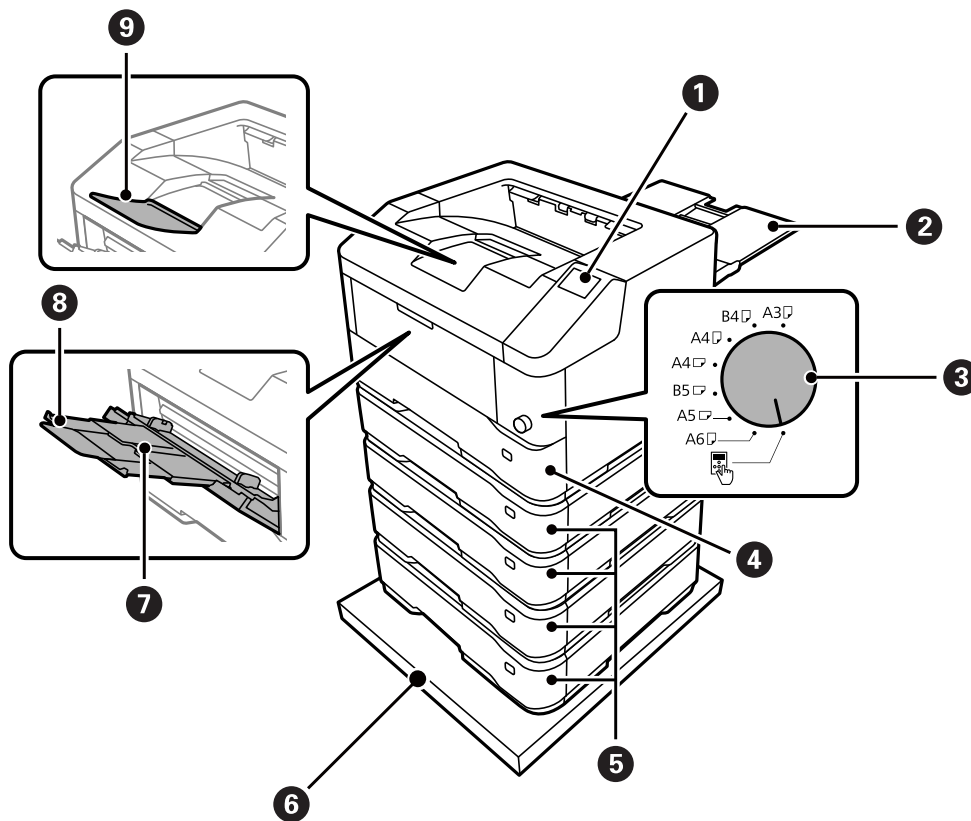

1	Control panel	Allows you to make settings and perform operations on the printer. Also displays the printer's status.
2	Face up tray*	Holds the ejected paper.
3	Paper size setting dial	Selects the paper size to be loaded in the paper tray.
4	Paper cassette 1 (C1)	Loads paper.
5	Paper cassette 2, 3, 4, 5 (C2, C3, C4, C5) *	Optional paper cassette units. Loads paper. Cassette 5 is only available for the AL-M8250DN/AL-M8150DN.
6	Printer stand*	Optional printer stand. The stand has casters allowing you to easily move the printer.
7	Paper tray (MP)	Loads all paper types supported by the printer.
8	Paper support	Supports loaded paper.
9	Output tray	Holds the ejected paper.

\* Optional item. See the Related Information below for details.

### Related Information

➔ [“List of Optional Items” on page 145](#)

# Inside

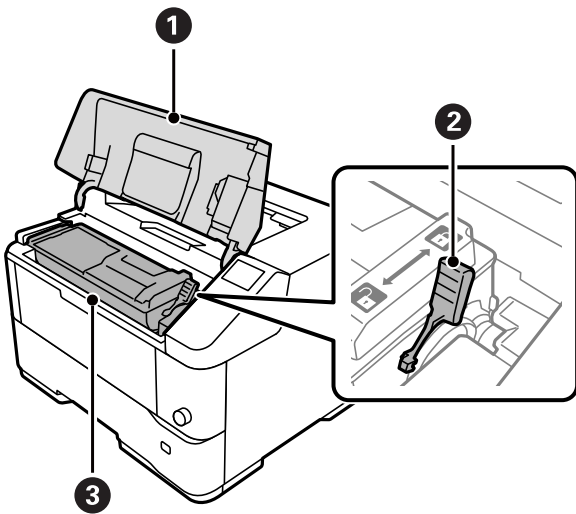

1	Printer cover (A)	Open when replacing toner cartridge.
2	Lever	Pull toward you to replace the toner cartridge.
3	Toner cartridge	Contains the toner for printing.

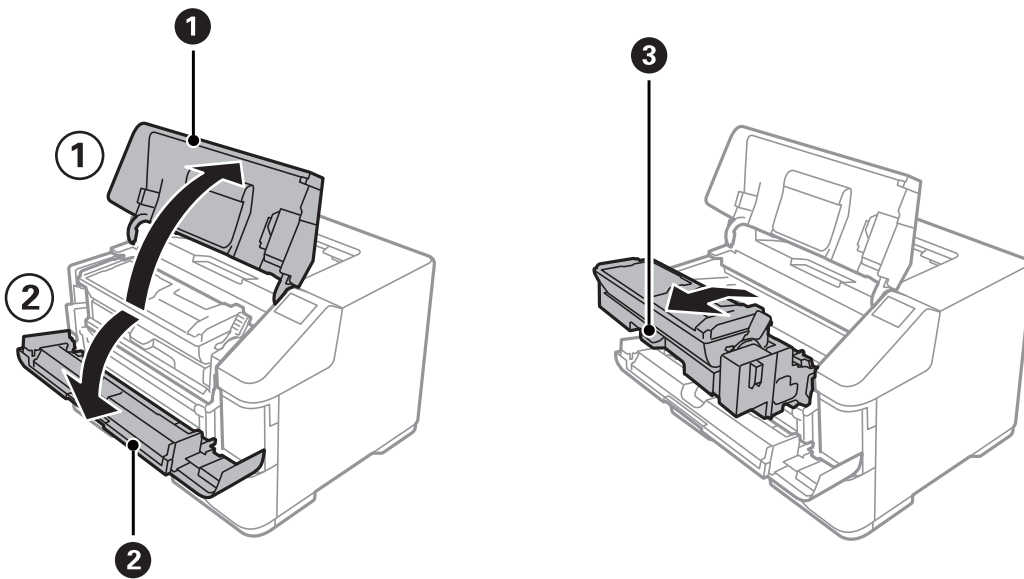

1	Printer cover (A)	Open when replacing toner cartridge.
2	Front cover (F)	Open when pulling out the development unit to remove jammed paper.

3	Development unit	Contains the developer and the toner.
---	------------------	---------------------------------------

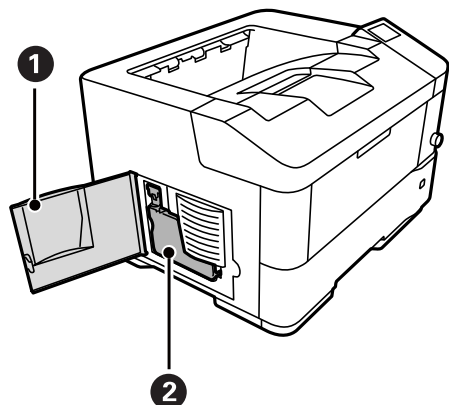

1	Waste toner collector cover (E)	Open when replacing the waste toner collector.
2	Waste toner collector	Collects toner wasted during printing.

## Rear

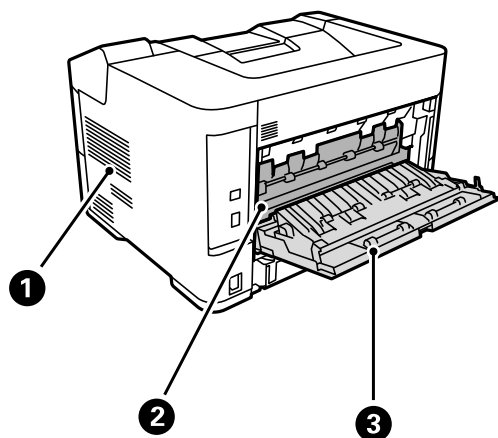

1	Vent	Releases heat from the inside of the printer. There are also vents on the lateral sides of the printer. Do not cover the vents when placing the printer.
---	------	--

<b>2</b>	Fuser unit cover	Open when removing jammed paper inside the printer.
<b>3</b>	Rear cover (B)	

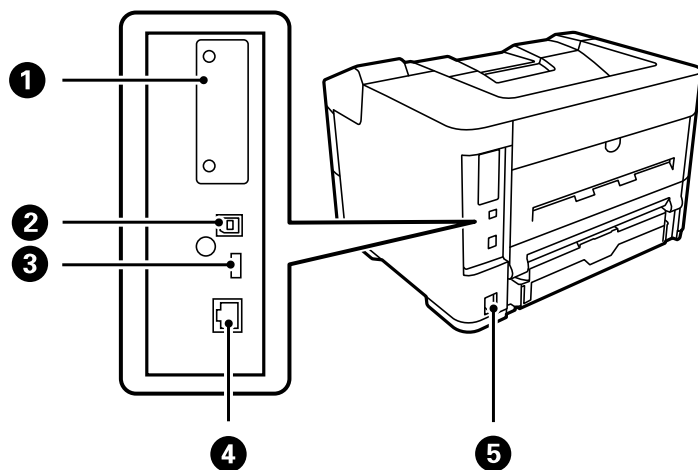

<b>1</b>	Additional interface slot	Insert an optional interface card. Only for the AL-M8250DN/AL-M8150DN.
<b>2</b>	USB port	Connects a USB cable to connect with a computer.
<b>3</b>	Service USB port	USB port for future use. Do not remove the cap.
<b>4</b>	LAN port	Connects a LAN cable.
<b>5</b>	AC inlet	Connects the power cord.



---

# Guide to the Control Panel

Control Panel. . . . .	26
Home Screen Configuration. . . . .	27
Menu Screen Configuration. . . . .	28
Entering Characters. . . . .	28
Viewing Animations. . . . .	29

## Control Panel

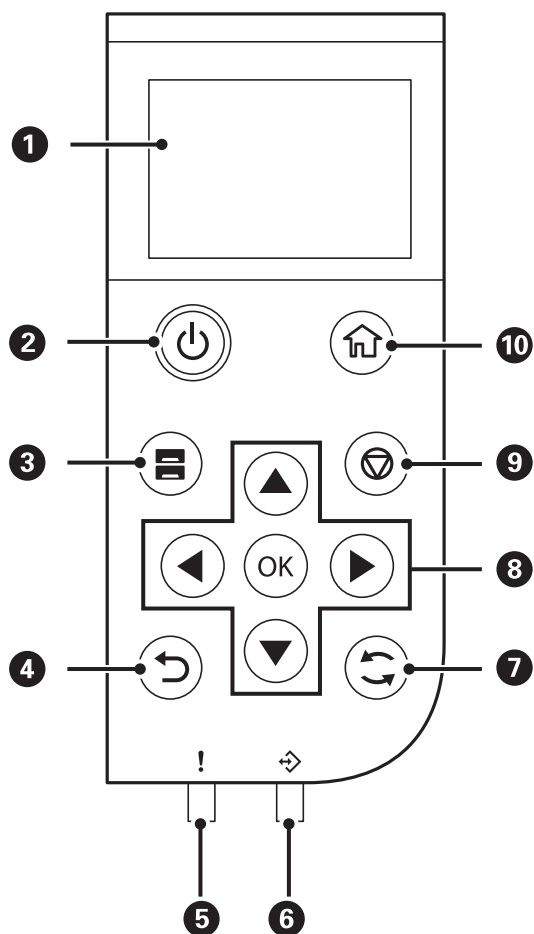

1	Displays menus and messages.
2	Turns the printer on or off. This turns on when you turn on the printer and flashes when the printer enters sleep mode. Press the button to wake the printer from sleep mode. Unplug the power cord when the power light is off.
3	Displays the Paper Setting screen. You can select the paper size and paper type settings for each paper source.
4	Returns to the previous screen.
5	Flashes or turns on when an error occurs.
6	Flashes when the printer is processing data. It turns on when there are queued jobs.
7	Applies to a variety of functions depending on the situation.
8	Move the focus using the ◀▶▶▼ buttons to select the items, and then press the OK button to confirm your selection or run the selected feature.
9	Stops the current operation.
10	Displays the home screen.

## Home Screen Configuration

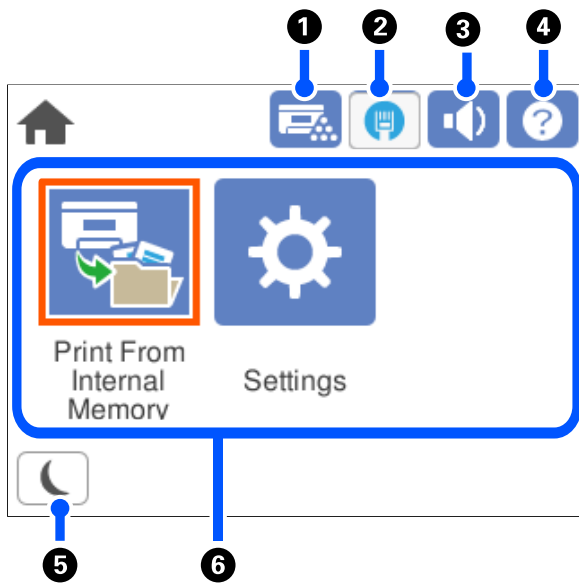



1		You can check the status of the printer and the consumables.
2		Displays the network connection status. See the following for more details. <a href="#">"Guide to the Network Icon" on page 27</a>
3		Displays the Sound screen. You can set <b>Mute</b> and <b>Normal Mode</b> . You can also make this setting from the <b>Settings</b> menu. <b>Settings &gt; General Settings &gt; Basic Settings &gt; Sound</b>
		Indicates that <b>Mute</b> is set for the printer.
4		Displays the Help screen. You can view the operating instructions or the solutions to problems.
5		Enters the printer into sleep mode. When the icon is grayed out, the printer cannot enter sleep mode.
6	Displays each menu. <ul style="list-style-type: none"> <li><input type="checkbox"/> Print From Internal Memory Allows you to temporarily save jobs sent from the printer driver to the printer's memory before printing. You can print a password protected job and test prints when printing multiple copies.</li> <li><input type="checkbox"/> Settings Allows you to make settings related to printer operations.</li> </ul>	

## Guide to the Network Icon

	The printer is not connected to a wired (Ethernet) network or unset it.
	The printer is connected to a wired (Ethernet) network.

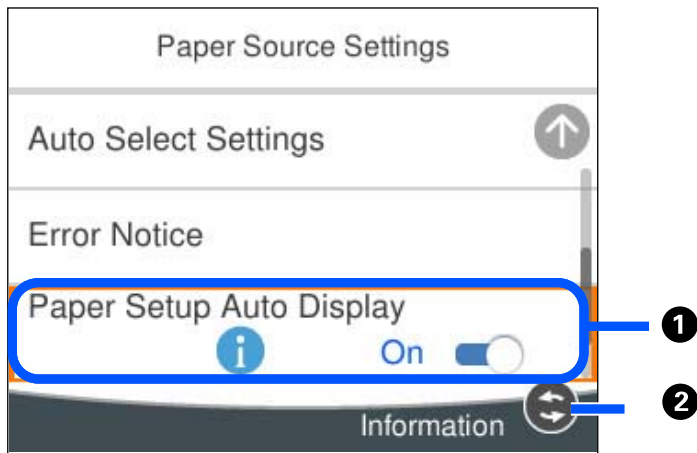
## Menu Screen Configuration



①	When  is displayed, you can view additional information by pressing  button.
②	Available buttons are displayed.

## Entering Characters

You can enter characters and symbols by using on-screen keyboard when you make network settings and so on.

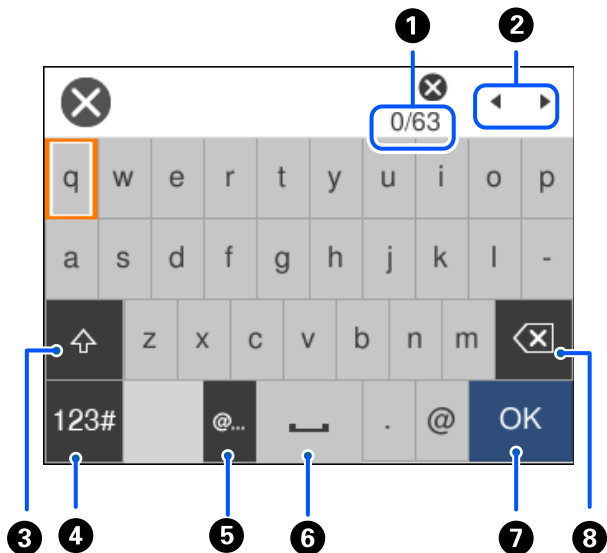

①	Indicates the character count.
②	Moves the cursor to the input position.
③	Switches between upper case and lower case.

4	Switches the character type. ABC: Alphabet 123#: Numbers and symbols
5	Enters frequently used email domain addresses or URLs by simply selecting the item.
6	Enters a space.
7	Enters character.
8	Deletes a character to the left. Deletes a character to the right when the cursor is at the start of the line and there are no characters to the left.

## Viewing Animations

You can view animations of operating instructions such as loading paper or removing jammed paper on the LCD screen.

- Select : Displays the help screen. Select **How To** and select the items that you want to view.

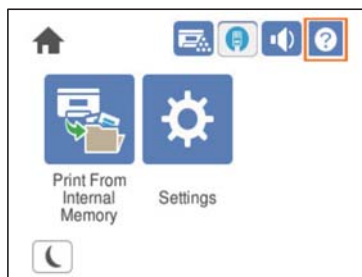

- Select **How To** at the bottom of the operation screen: Displays the context-sensitive animation.

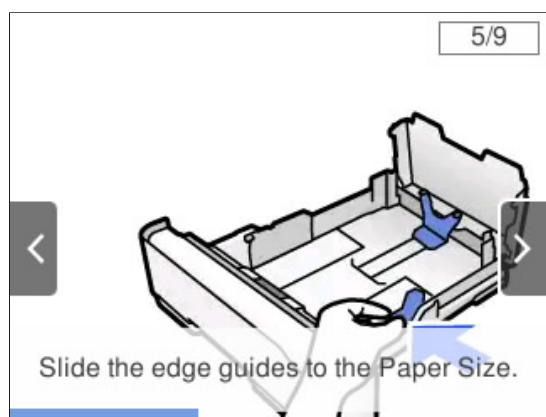

---

# Loading Paper

Paper Handling Precautions. . . . .	31
Paper Size and Type Settings. . . . .	32
Loading Paper. . . . .	32
Paper Eject Setting. . . . .	33

## Paper Handling Precautions

### Paper

- ❑ Check the available paper and capacities.
- ❑ Fan and align the edges of the paper before loading.

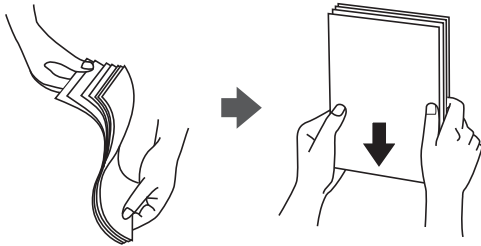

- ❑ If the paper is curled, flatten it or curl it slightly in the opposite direction before loading.



- ❑ If paper feed problems occur, load paper upside down.

### Envelope

- ❑ Depending on the type of envelope, storage and printing environment, and printing method, wrinkles may be noticeable. We recommend performing a test print.
- ❑ If you cannot feed envelopes correctly, try reducing the number of envelopes and you may be able to feed them correctly.
- ❑ If you cannot feed envelopes correctly even if the leading edge of the envelope is firmly inserted into the paper tray, make sure the leading edge of the envelope is not curled down. If it is curled, flatten it and then reload it.

### Related Information

- ➔ [“Unavailable Paper Types” on page 178](#)

## Paper Size and Type Settings

If you register the paper size and type on the screen displayed when you insert the paper cassette, the printer informs you when the registered information and print settings differ. This can help prevent poor toner fusing or paper feed problems when printing due to paper type mismatches, which saves you from wasting paper and toner.

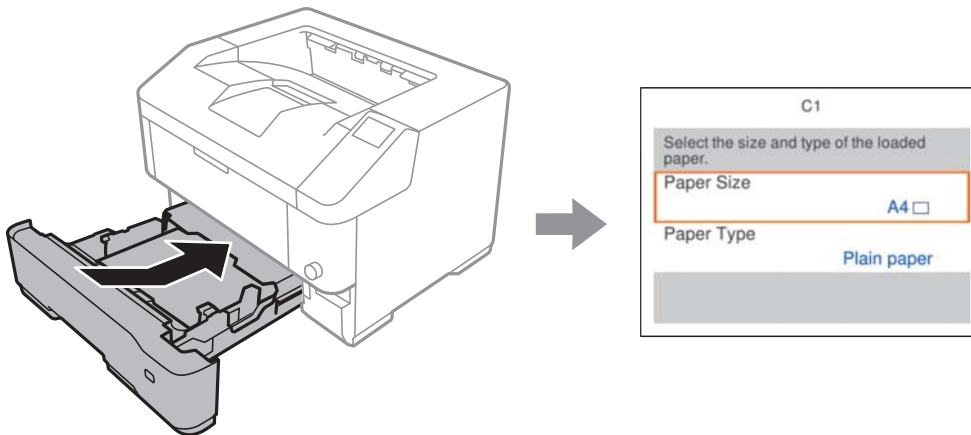

If displayed paper size and type differ from the loaded paper, select the item to change. If the settings match the loaded paper, close the screen.

**Note:**

You can also display the paper size and paper type settings screen by pressing the  button on the control panel.

You cannot select the paper size if the paper size setting dial is not set to Panel.

## Loading Paper

You can load paper by referring to the animations displayed on the printer's LCD screen.

Select  , and then select **How To > Load paper**. Select the paper type and paper source you want to use to display the animations. Select **Finish** to close the animation screen.





**!** **Important:**

- Do not pull out two or more paper cassettes at the same time. Doing so may cause the printer to become unstable and fall down.
- Do not pull out a paper cassette while printing.
- Do not push the paper cassette with too much force. Doing so may cause the paper to become misaligned causing a skewed feed or paper jam.
- Do not load more than the maximum number of sheets specified for envelopes as it may cause paper feed problems.
- Be sure to adjust the edge guide to the size of the paper being loaded. If the paper size is incorrect, it may cause a paper feed problem, paper jam, or error.
- If setting for the paper size setting dial differs from the loaded paper size, paper jams or errors may occur. Make sure these settings match.
- If the paper type is not set correctly, it may cause printing problems.
- When printing on paper other than standard paper, be sure to specify the paper size in **User Defined Size (Windows)** / **Manage Custom Size (Mac OS)** in the printer driver. If you continue to print with a different paper size selected, the fuser inside the printer may be damaged.

**Note:**

If the paper runs out during printing, a buzzer will sound. You can adjust the volume to **High, Medium, Low**, or **Off**. If **Mute** is set on the control panel, the buzzer does not sound.

**Related Information**

➔ [“Available Paper and Capacities” on page 176](#)

## Loading Envelopes

Load envelopes with the printable side facing up in the paper tray.

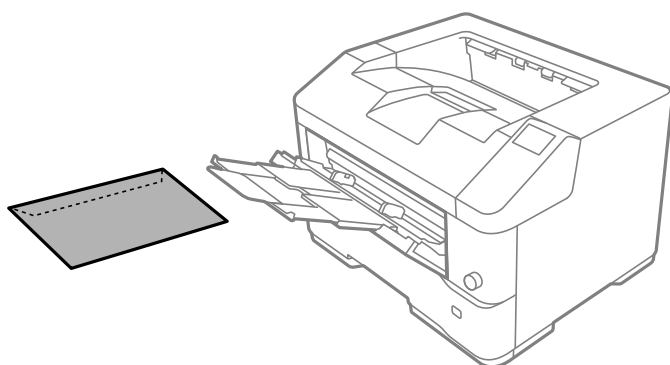

---

## Paper Eject Setting

Eject the paper with the printed side facing down. For A4 size plain paper, you can eject up to 550 sheets at a time. For paper that can be loaded vertically or horizontally (A4/A5), you can change the paper ejection direction. In addition, when printing in sets, the sets can be output alternately vertically and horizontally making them easier to stack.

## Selecting Paper Eject Direction

1. When paper is loaded in the paper tray, set the paper size (direction) on the control panel.

Setting items: Paper Size

Setting values: A4 , A4 , A5 , A5 

2. Specify the paper output direction in the printer driver.

Windows: **Main > Paper Output Settings**



Mac OS: **Print Settings > Output Direction**

When you select **Non-standard**, you can print and eject on a paper source that has been loaded in a different direction from the standard (A4 landscape/A5 portrait).

## Ejecting Paper in Portrait or Landscape Alternately

1. Load A4 size paper horizontally in one of the paper sources and vertically in the other.
2. If paper is loaded in the paper tray, set the paper size (orientation) on the control panel.

Setting items: Paper Size

Setting values: A4 , A4 

3. Select **Collated** in the printer driver, and set the paper source to **Auto Select**.

Windows: **Main > Paper Source**

Mac OS: **Print Settings > Paper Source**

4. Select **Standard and Non-standard Alternately** in the output settings.

Windows: **Main > Paper Output Settings**

Mac OS: **Print Settings > Output Direction**

5. Specify the number of copies, and then print.

---

# Printing

Printing Documents. . . . .	36
Printing on Envelopes. . . . .	86
Printing Web Pages. . . . .	87
Printing Using a Cloud Service. . . . .	88

# Printing Documents

## Printing from a Computer - Windows

If you cannot change some of the printer driver settings, they may have been restricted by the administrator. Contact your printer administrator for assistance.

### Printing Using Easy Settings

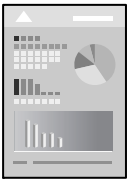

**Note:**

Operations may differ depending on the application. See the application's help for details.

1. Load paper in the printer.  
    [“Loading Paper” on page 32](#)
2. Open the file you want to print.
3. Select **Print** or **Print Setup** from the **File** menu.
4. Select your printer.
5. Select **Preferences** or **Properties** to access the printer driver window.

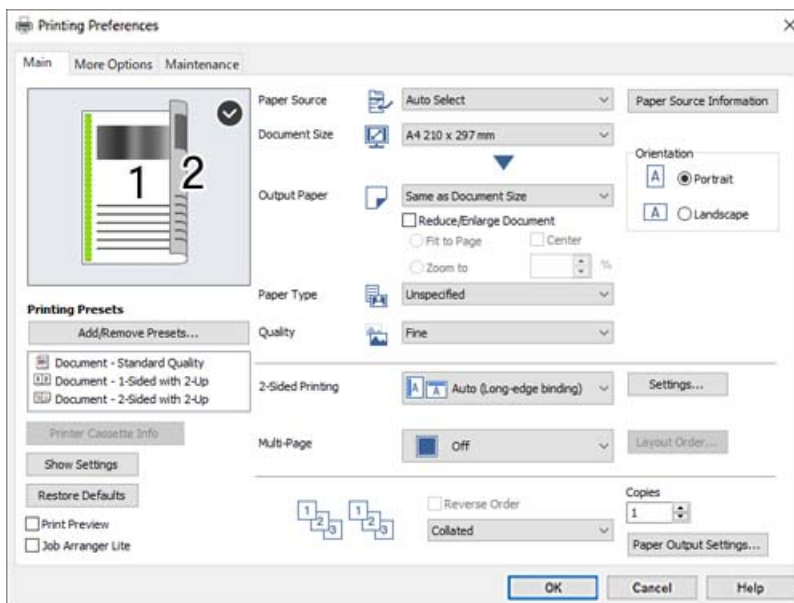

6. Change the settings as necessary.

See the menu options for the printer driver for details.

**Note:**

- You can also see the online help for explanations of the setting items. Right-clicking an item displays **Help**.
- When you only want to print on one side of the paper, set **2-Sided Printing** to **Off**.
- When you select **Print Preview**, you can see a preview of your document before printing.

7. Click **OK** to close the printer driver window.

8. Click **Print**.

**Note:**

If you want to cancel printing, on your computer right-click on your printer in **Devices and Printers**, **Printer**, or in **Printers and Faxes**. Click **See what's printing**, right-click on the job you want to cancel, and then select **Cancel**. However, you cannot cancel a print job from the computer once it has been completely sent to the printer. In this case, cancel the print job by using the printer's control panel.

### Related Information

- ➔ [“Available Paper and Capacities” on page 176](#)
- ➔ [“Menu Options for the Printer Driver” on page 37](#)

### Menu Options for the Printer Driver

Open the print window in an application, select the printer, and then access the printer driver window.

**Note:**

Menus vary depending on the option you selected.

### Main Tab

#### Printing Presets:

##### Add/Remove Presets:

You can add or remove your own presets for frequently used print settings. Select the preset you want to use from the list.

#### Printer Cassette Info:

Click to open the EPSON Status Monitor that can help you check the printer status. You need to install EPSON Status Monitor to enable this feature. You can download it from the Epson website.

<http://www.epson.com>

#### Show Settings/Hide Settings:

Displays a list of items currently set on the **Main** and **More Options** tabs. You can show or hide the current setting list screen.

#### Restore Defaults:

Return all settings to their factory default values. The settings on the **More Options** tab are also reset to their defaults.

**Print Preview:**

Displays a preview of your document before printing.

**Job Arranger Lite:**

Job Arranger Lite allows you to combine several files created by different applications and print them as a single print job.

**Paper Source:**

Select the paper source from which the paper is fed. Select **Auto Select** to automatically select the paper source selected in the print settings on the printer.

**Document Size:**

Select the paper size on which you want to print. If you select **User Defined Size**, enter the paper width and height, and then register the size.

**Output Paper:**

Select the paper size on which you want to print. If the **Document Size** differs from the **Output Paper**, **Reduce/Enlarge Document** is selected automatically. You do not have to select it when printing without reducing or enlarging the size of a document.

**Reduce/Enlarge Document:**

Allows you to reduce or enlarge the size of a document.

**Fit to Page:**

Automatically reduce or enlarge the document to fit to the paper size selected in **Output Paper**.

**Zoom to:**

Prints with a specific percentage.

**Center:**

Prints images in the center of the paper.

**Paper Type:**

Select the type of paper on which you print. If you select **Unspecified**, printing is performed from the paper source for which the paper type is set to the following in the printer's settings.

Plain, Letterhead, Recycled, Color, Preprinted, Semi-Thick, Thick paper1, Thick paper2, Thick paper3, Thin, Transparency, Labels, or Special

However, paper cannot be fed from a paper source for which the paper source is set to off in the printer's **Auto Select Settings**.

**Quality:**

Select the print quality you want to use for printing. Available settings depend on the paper type you select. If you select **More Settings**, you can make additional print quality settings.

**Paper Source Information:**

Displays the paper information set for each paper source.

**Orientation:**

Select the orientation you want to use to print.

**2-Sided Printing:**

Allows you to perform 2-sided printing.

**Settings:**

You can specify the binding edge and the binding margins. When printing multi-page documents, you can select to print starting from either the front or the back side of the page.

**Multi-Page:**

Allows you to print several pages on one sheet or perform poster printing. Click **Layout Order** to specify the order in which pages are printed.

**Reverse Order:**

Allows you to print from the last page so that the pages are stacked in the correct order after printing.

**Collated/Uncollated:**

Select **Collated** to print multi-page documents collated in order and sorted into sets.

**Copies:**

Set the number of copies you want to print.

**Paper Output Settings:**

Selects the paper output orientation for the paper sizes which are supported to be fed in both portrait and landscape orientations. If you select the face up as the output tray, install the optional face up tray.

**More Options Tab**

**Printing Presets:**

**Add/Remove Presets:**

You can add or remove your own presets for frequently used print settings. Select the preset you want to use from the list.

**Show Settings/Hide Settings:**

Displays a list of items currently set on the **Main** and **More Options** tabs. You can show or hide the current setting list screen.

**Restore Defaults:**

Return all settings to their factory default values. The settings on the **Main** tab are also reset to their defaults.

**Job Type:**

Select **Confidential Job** to set a password to protect confidential documents when printing. If you use this feature, the print data is stored in the printer and can only be printed after the password has been entered using the printer's control panel. Click **Confidential Job Settings** to change the settings.

#### Tone Correction:

##### Automatic:

Adjusts the tone of images automatically.

##### Custom:

Allows you to perform manual tone correction. Click **Advanced** for further settings.

##### Image Options:

Sharpens fine letters and lines. If you want to make thick lines thin, select **None**. If you select **Visibility**, colored text, graphs, and images will be decorated and printed so that they are easy to see when printed in black and white.

#### Additional Settings:

##### Watermark Features:

Allows you to make settings for anti-copy patterns, watermarks, or headers and footers.

##### Add/Delete:

Allows you to add or remove any anti-copy patterns or watermarks that you want to use.

##### Settings:

Allows you to set the printing method for anti-copy patterns or watermarks.

##### Header/Footer:

You can print information such as a user name and printing date in headers or footers.

##### Form Overlay:

Allows you to print a standard form or letterhead onto original documents.

##### Rotate 180°:

Rotates pages 180 degrees before printing. Select this item when printing on paper such as envelopes that are loaded in fixed direction in the printer.

## Maintenance Tab

#### Print Status Sheets:

Print a status sheet with printer information, consumables information, and usage history.

#### Job Arranger Lite:

Opens the Job Arranger Lite window. Here you can open and edit previously saved data.

#### EPSON Status Monitor:

Opens the EPSON Status Monitor window. Here you can confirm the status of the printer and the consumables. You need to install EPSON Status Monitor to enable this feature. You can download it from the Epson website.

<http://www.epson.com>



#### Monitoring Preferences:

Set the monitoring conditions for the EPSON Status Monitor. You need to install EPSON Status Monitor to enable this feature. You can download it from the Epson website.

<http://www.epson.com>

#### Extended Settings:

Allows you to make a variety of settings. Right-click each item to view the Help for more details.

#### Print Queue:

Displays the jobs waiting to be printed. You can check, pause, or resume print jobs.

#### Printer and Option Information:

You can check printer settings and optional device settings.

#### Language:

Changes the language to be used on the printer driver window. To apply the settings, close the printer driver, and then open it again.

#### Software Update:

Starts EPSON Software Updater to check for the latest version of applications on the Internet.

#### Technical Support:

If the manual is installed on your computer, the manual is displayed. If it is not installed, you can connect to the Epson Web site to check the manual and available technical support.

## Adding Printing Presets for Easy Printing

If you create your own preset of frequently used print settings on the printer driver, you can print easily by selecting the preset from the list.

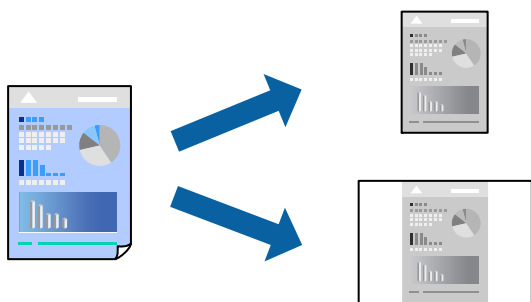

1. On the printer driver's **Main** or **More Options** tab, set each item (such as **Document Size** and **Paper Type**).
2. Click **Add/Remove Presets** in **Printing Presets**.
3. Enter a **Name** and, if necessary, enter a comment.

4. Click **Save**.

**Note:**

To delete an added preset, click **Add/Remove Presets**, select the preset name you want to delete from the list, and then delete it.

[“Main Tab” on page 37](#)

[“More Options Tab” on page 39](#)

5. Click **Print**.

The next time you want to print using the same settings, select the registered setting name from **Printing Presets**, and click **OK**.

### Related Information

- ➔ [“Loading Paper” on page 32](#)
- ➔ [“Printing Using Easy Settings” on page 36](#)

## Printing on 2-Sides

You can print on both sides of the paper.

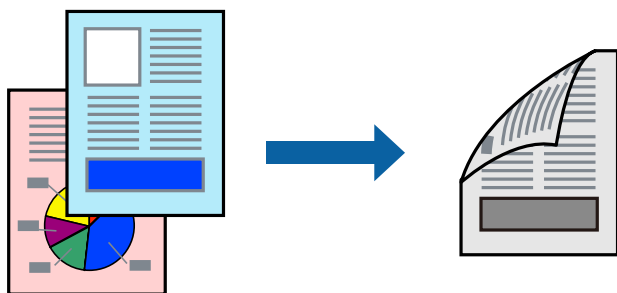

**Note:**

- If you do not use paper that is suitable for 2-sided printing, the print quality may decline and paper jams may occur.  
[“Paper for Automatic 2-Sided Printing” on page 178](#)
- This needs to be installed if you want to check the printing status with **EPSON Status Monitor**. You can download it from the Epson website.  
<http://www.epson.com>

1. On the printer driver's **Main** tab, select 2-Sided Printing.
2. Click **Settings**, make the appropriate settings, and then click **OK**.
3. Set the other items on the **Main** and **More Options** tabs as necessary, and then click **OK**.  
[“Main Tab” on page 37](#)  
[“More Options Tab” on page 39](#)
4. Click **Print**.

## Related Information

- ➔ “Available Paper and Capacities” on page 176
- ➔ “Loading Paper” on page 32
- ➔ “Printing Using Easy Settings” on page 36

## Printing a Booklet

You can also print a booklet that can be created by re-ordering the pages and folding the printout.

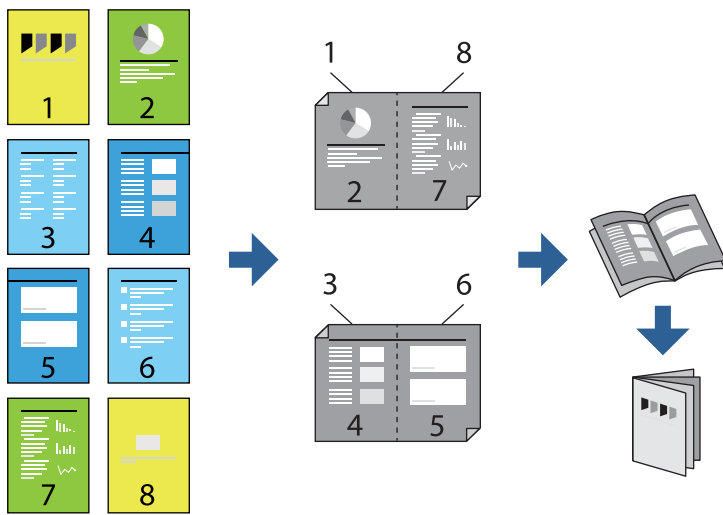

### Note:

- If you do not use paper that is suitable for 2-sided printing, the print quality may decline and paper jams may occur.  
“Paper for Automatic 2-Sided Printing” on page 178

- This needs to be installed if you want to check the printing status with **EPSON Status Monitor**. You can download it from the Epson website.  
<http://www.epson.com>

1. On the printer driver's **Main** tab, select the type of long-edge binding you want to use from **2-Sided Printing**.
2. Click **Settings**, select **Booklet**, and then select **Center Binding** or **Side Binding**.
  - Center Binding: Use this method when printing a small number of pages that can be stacked and easily folded in half.
  - Side Binding. Use this method when printing one sheet (four pages) at a time, folding each in half, and then putting them together in one volume.
3. Click **OK**.
4. Set the other items on the **Main** and **More Options** tabs as necessary, and then click **OK**.  
“Main Tab” on page 37  
“More Options Tab” on page 39
5. Click **Print**.

### Related Information

- ➔ “Available Paper and Capacities” on page 176
- ➔ “Loading Paper” on page 32
- ➔ “Printing Using Easy Settings” on page 36

## Printing Several Pages on One Sheet

You can print several pages of data on a single sheet of paper.

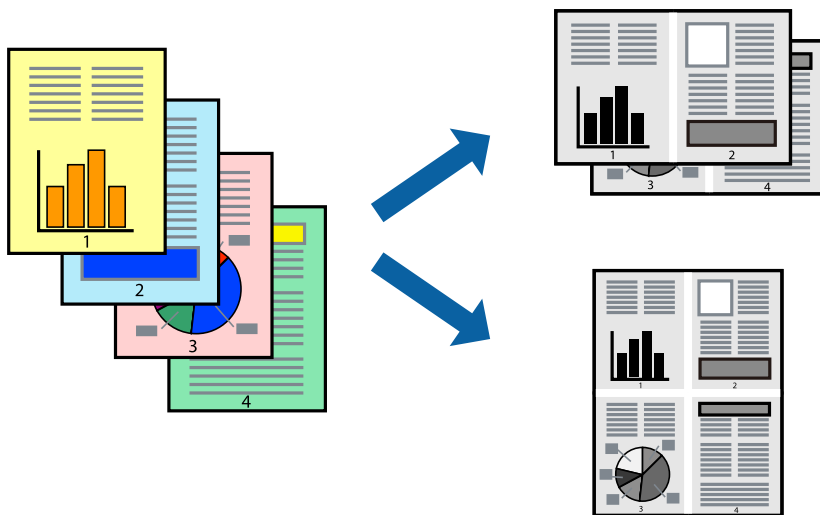

1. On the printer driver's **Main** tab, select **2-Up**, **4-Up**, **6-Up**, **8-Up**, **9-Up**, or **16-Up** as the **Multi-Page** setting.
2. Click **Layout Order**, make the appropriate settings, and then click **OK**.
3. Set the other items on the **Main** and **More Options** tabs as necessary, and then click **OK**.
  - “Main Tab” on page 37
  - “More Options Tab” on page 39
4. Click **Print**.

### Related Information

- ➔ “Loading Paper” on page 32
- ➔ “Printing Using Easy Settings” on page 36

## Printing to Fit the Paper Size

Select the paper size you loaded in the printer as the Destination Paper Size setting.

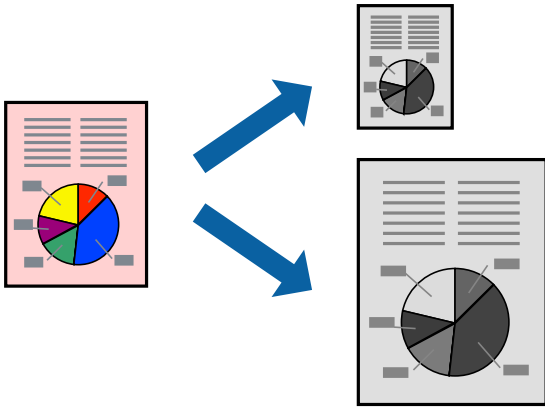

1. On the printer driver's **Main** tab, make the following settings.
  - Document Size: Select the size of the paper you set in the application setting.
  - Output Paper: Select the paper size you loaded in the printer.  
**Fit to Page** is automatically selected.

**Note:**

Click **Center** to print the reduced image in the middle of the paper.

2. Set the other items on the **Main** and **More Options** tabs as necessary, and then click **OK**.
  - [“Main Tab” on page 37](#)
  - [“More Options Tab” on page 39](#)
3. Click **Print**.

### Related Information

- ➔ [“Loading Paper” on page 32](#)
- ➔ [“Printing Using Easy Settings” on page 36](#)

## Printing a Reduced or Enlarged Document at any Magnification

You can reduce or enlarge the size of a document by a specific percentage.



1. On the printer driver's **Main** tab, select the document size from the **Document Size** setting.
2. Select the paper size you want to print on from the **Output Paper** setting.
3. Select **Zoom to**, and then enter a percentage. If you have selected **Same as Document Size** as the **Output Paper**, select **Reduce/Enlarge Document** first.
4. Set the other items on the **Main** and **More Options** tabs as necessary, and then click **OK**.  
[“Main Tab” on page 37](#)  
[“More Options Tab” on page 39](#)
5. Click **Print**.

### Related Information

- ➔ [“Loading Paper” on page 32](#)
- ➔ [“Printing Using Easy Settings” on page 36](#)

## Printing One Image on Multiple Sheets for Enlargement (Creating a Poster)

This feature allows you to print one image on multiple sheets of paper. You can create a larger poster by taping them together.

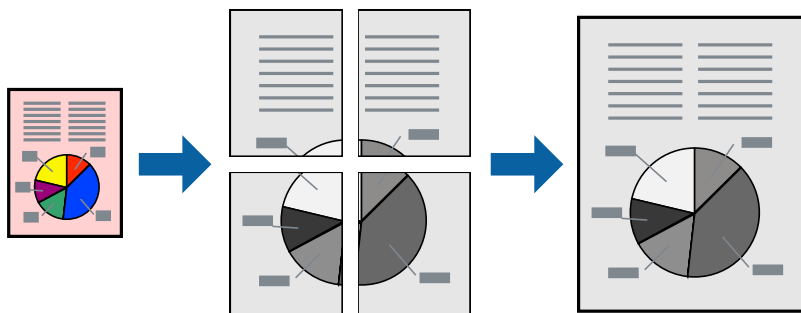

1. On the printer driver's **Main** tab, select **Off** from **2-Sided Printing**.
2. Select **2x1 Poster**, **2x2 Poster**, **3x3 Poster**, or **4x4 Poster** as the **Multi-Page** setting.
3. Click **Settings**, make the appropriate settings, and then click **OK**.

**Note:**

*Print Cutting Guides* allows you to print a cutting guide.

4. Set the other items on the **Main** and **More Options** tabs as necessary, and then click **OK**.  
[“Main Tab” on page 37](#)  
[“More Options Tab” on page 39](#)
5. Click **Print**.

### Related Information

- ➔ [“Loading Paper” on page 32](#)
- ➔ [“Printing Using Easy Settings” on page 36](#)

### ***Making Posters Using Overlapping Alignment Marks***

Here is an example of how to make a poster when **2x2 Poster** is selected, and **Overlapping Alignment Marks** is selected in **Print Cutting Guides**.

The actual guides are printed in monochrome, but for this explanation they are shown as blue and red lines.

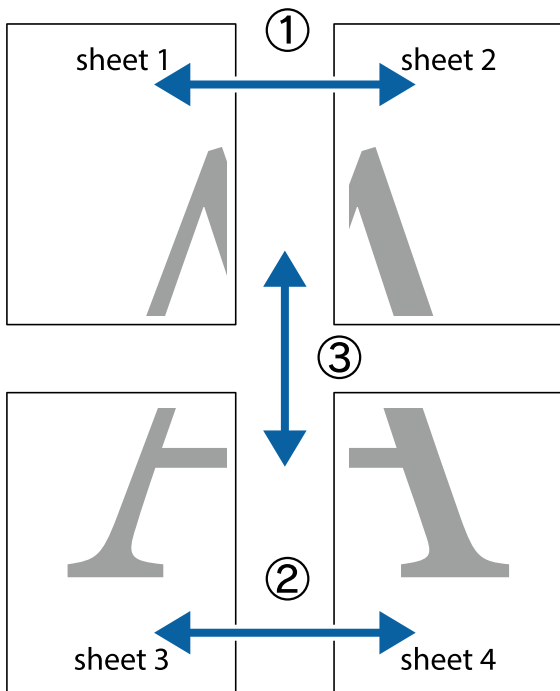

1. Prepare Sheet 1 and Sheet 2. Cut off the margins of Sheet 1 along the vertical blue line through the center of the top and bottom cross marks.

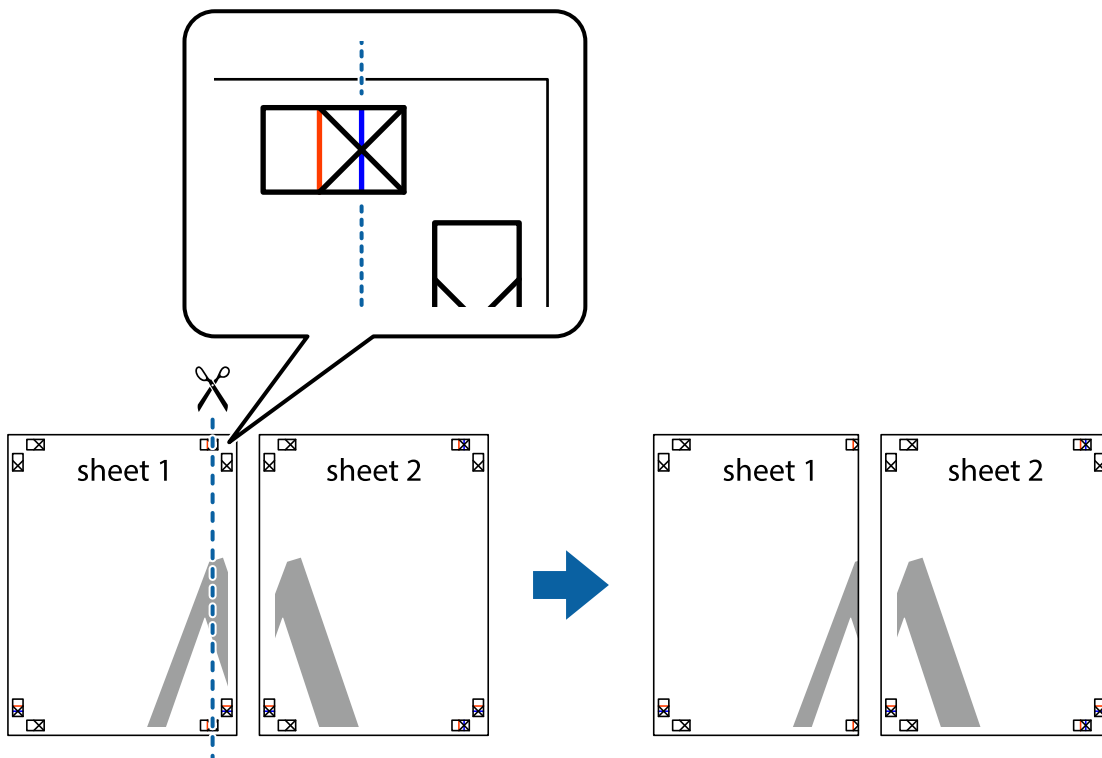



2. Place the edge of Sheet 1 on top of Sheet 2 and align the cross marks, then temporarily tape the two sheets together from the back.

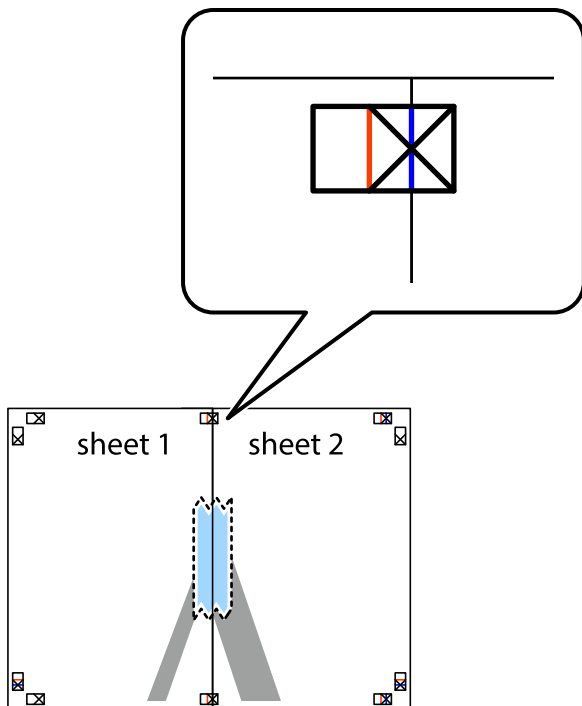

3. Cut the taped sheets in two along the vertical red line through the alignment markers (this time, the line to the left of the cross marks).

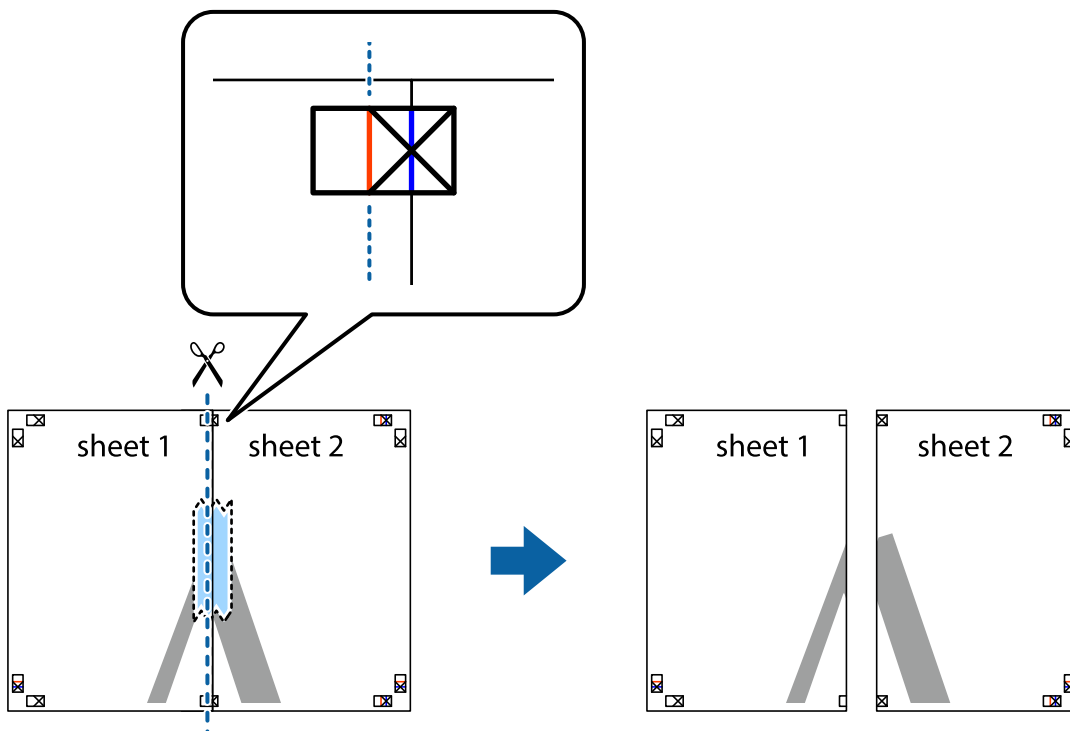

4. Tape the sheets together from the back.

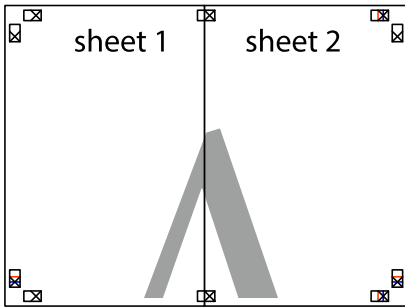

5. Repeat steps 1 to 4 to tape Sheet 3 and Sheet 4 together.
6. Cut off the margins of Sheet 1 and Sheet 2 along the horizontal blue line through the center of the left and right side cross marks.

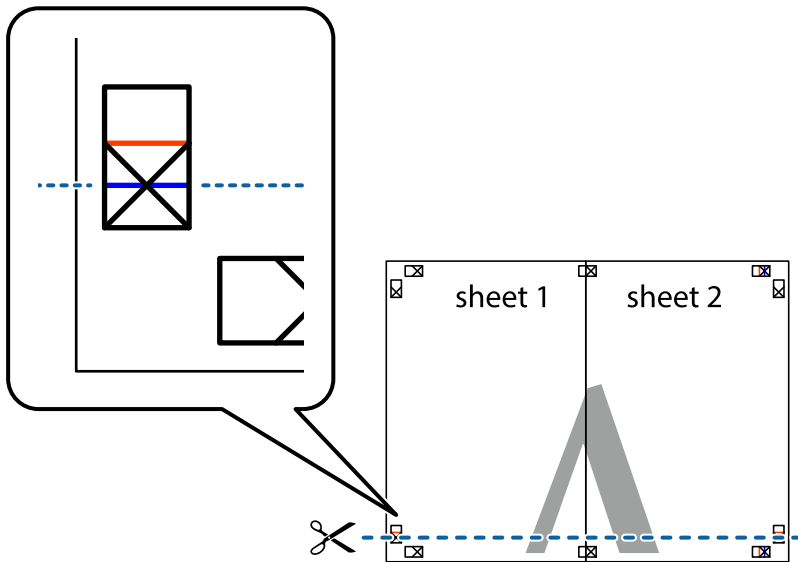

7. Place the edge of Sheet 1 and Sheet 2 on top of Sheet 3 and Sheet 4 and align the cross marks, and then temporarily tape them together from the back.

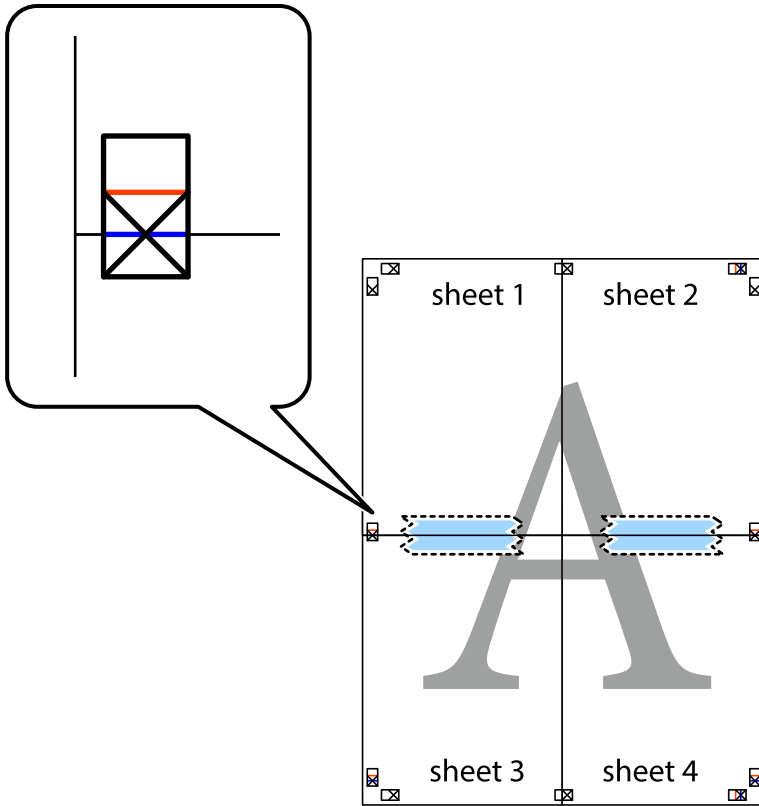

- Cut the taped sheets in two along the horizontal red line through the alignment markers (this time, the line above the cross marks).

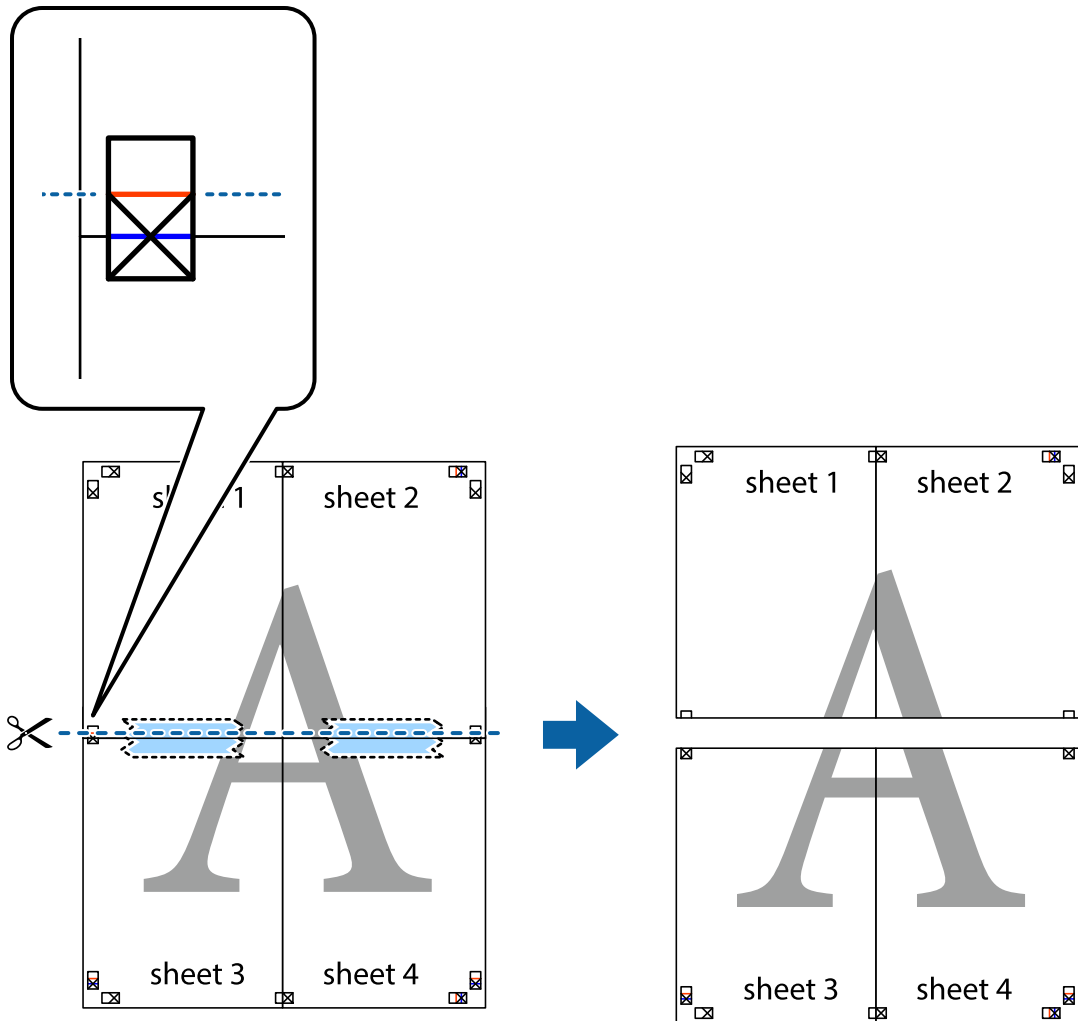

- Tape the sheets together from the back.

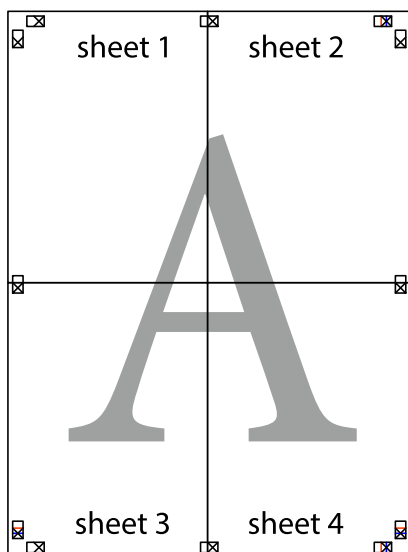

10. Cut off the remaining margins along the outer guide.

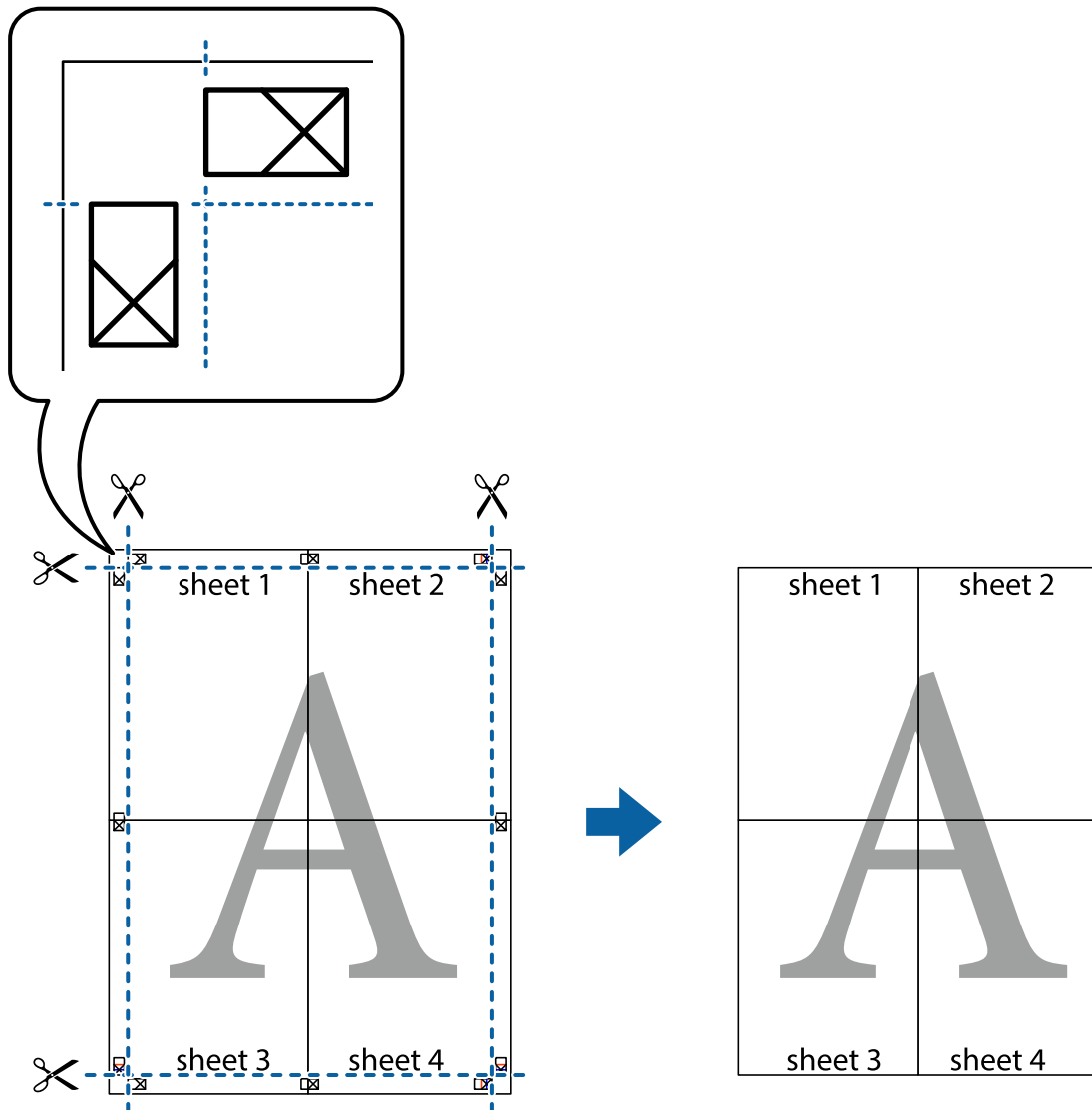

## Printing with a Header and Footer

You can print information such as a user name and printing date in headers or footers.

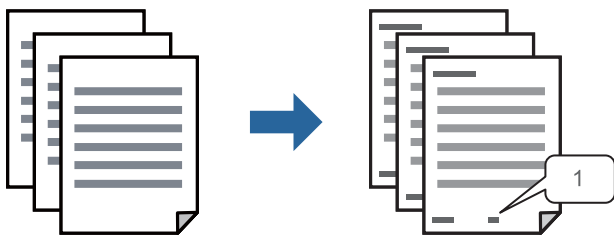

1. On the printer driver's **More Options** tab, click **Watermark Features**, and then select the **Header/Footer** checkbox.

2. Select **Settings**, select the items you want to print, and click OK.

**Note:**

- To specify the first page number, select **Page Number** from the position you want to print in the header or footer, and then select the number in **Starting number**.
- If you want to print text in the header or footer, select the position you want to print, and then select **Text**. Enter the text you want to print in the text input field.

3. Set the other items on the **Main** and **More Options** tabs as necessary, and then click **OK**.

[“Main Tab” on page 37](#)

[“More Options Tab” on page 39](#)

4. Click **Print**.

### Related Information

- ➔ [“Loading Paper” on page 32](#)
- ➔ [“Printing Using Easy Settings” on page 36](#)

## Printing an Anti-Copy Pattern

You can print an anti-copy pattern on your printouts. When printing, the letters themselves are not printed and the entire print is screen-toned lightly. The hidden letters appear when photocopied to easily distinguish the original from the copies.



Anti-Copy Pattern is available under the following conditions:

Quality: Fine

**Note:**

*You can also add your own anti-copy pattern.*

1. On the printer driver's **More Options** tab, click **Watermark Features**, and then select anti-copy pattern.
2. Click **Settings** to change details such as the size or density of the pattern.
3. Set the other items on the **Main** and **More Options** tabs as necessary, and then click **OK**.

[“Main Tab” on page 37](#)

[“More Options Tab” on page 39](#)

4. Click **Print**.

### Related Information

- ➔ [“Loading Paper” on page 32](#)

➔ [“Printing Using Easy Settings” on page 36](#)

## Printing Password-Protected Files

You can set a password for a print job so that it starts printing only after entering the password on the printer's control panel.

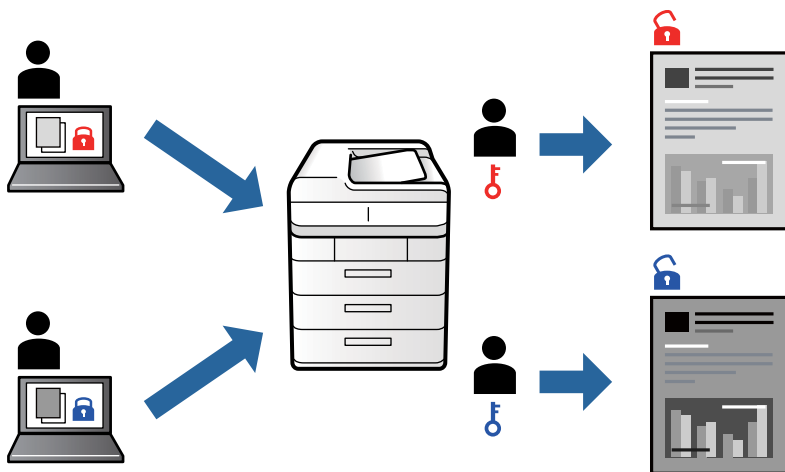

1. On the printer driver's **More Options** tab, select **Confidential Job** in the **Job Type** and then enter a password.
2. Set the other items on the **Main** and **More Options** tabs as necessary, and then click **OK**.  
[“Main Tab” on page 37](#)  
[“More Options Tab” on page 39](#)
3. Click **Print**.
4. To print the job, select **Print From Internal Memory** on the home screen of the printer's control panel. Select the job you want to print, and then enter the password.

### Related Information

- ➔ [“Loading Paper” on page 32](#)
- ➔ [“Printing Using Easy Settings” on page 36](#)

## Printing One Copy Before Printing Additional Copies

When printing a large volume of documents, you can print one copy to check the contents. To print after making the second copy, operate the printer's control panel. This feature is available when an optional HDD is installed.

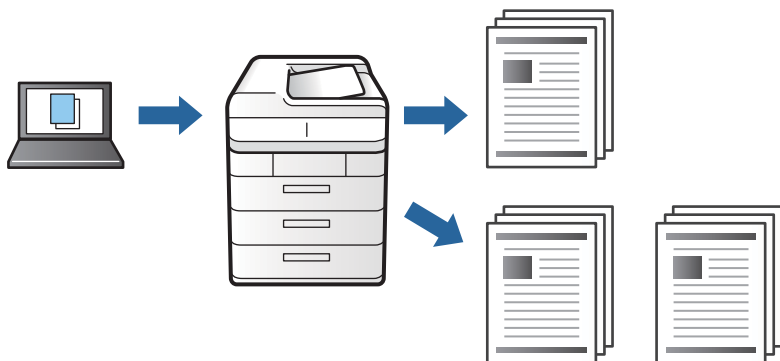

1. On the printer driver's **More Options** tab, select **Verify Job** as the **Job Type** setting.
2. Click **Settings**, enter the **User Name** and **Job Name**, and then click **OK**.  
You can identify the job by using the job name on the printer's control panel.
3. Set the other items on the **Main** and **More Options** tabs as necessary, and then click **OK**.  
[“Main Tab” on page 37](#)  
[“More Options Tab” on page 39](#)
4. Click **Print**.  
Only one copy is printed, and the print job is stored in the printer's memory.  
The stored job is deleted when the printer is turned off.
5. To print the job, select **Print From Internal Memory** on the home screen of the printer's control panel.
6. Select the job you want to print.  
Select the User from the list, and then select the job. If you are asked to enter a password, enter the one you set on the printer driver.
7. If the job details are displayed, close that screen and select **Print**.  
**Note:**  
Select **Delete** to delete the job.

### Related Information

- ➔ [“Loading Paper” on page 32](#)
- ➔ [“Printing Using Easy Settings” on page 36](#)



## Storing Print Jobs in the Printer's Memory and Reprinting

Allows you to store the print job in the printer's memory. You can start printing by operating the printer's control panel. This feature is available when an optional HDD is installed.

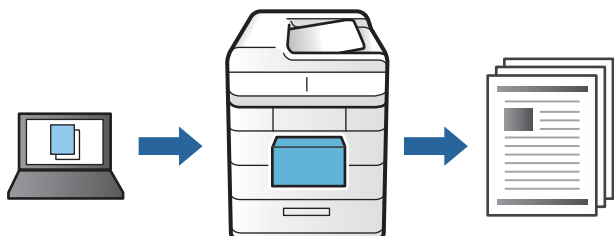

1. On the printer driver's **More Options** tab, select **Re-Print Job** as the **Job Type** setting.
2. Click **Settings**, enter the **User Name** and **Job Name**, and then click **OK**.  
You can identify the job by using the job name on the printer's control panel.
3. Set the other items on the **Main** and **More Options** tabs as necessary, and then click **OK**.  
[“Main Tab” on page 37](#)  
[“More Options Tab” on page 39](#)
4. Click **Print**.
5. To print the job, select **Print From Internal Memory** on the home screen of the printer's control panel.
6. Select the job you want to print.  
Select the User from the list, and then select the job. If you are asked to enter a password, enter the one you set on the printer driver.
7. If the job details are displayed, close that screen and select **Print**.  
**Note:**  
Select **Delete** to delete the job.

### Related Information

- ➔ [“Loading Paper” on page 32](#)
- ➔ [“Printing Using Easy Settings” on page 36](#)

## Printing Multiple Files Together

Job Arranger Lite allows you to combine several files created by different applications and print them as a single print job. You can specify the print settings for combined files, such as multi-page layout, and 2-sided printing.

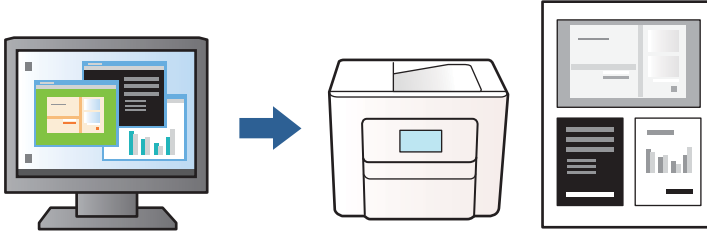

1. On the printer driver's **Main** tab, select **Job Arranger Lite**.  
[“Main Tab” on page 37](#)
2. Click **Print**.  
When you start printing, the Job Arranger Lite window is displayed.
3. With the Job Arranger Lite window opened, open the file that you want to combine with the current file, and then repeat the above steps.
4. When you select a print job added to Print Project Lite in the Job Arranger Lite window, you can edit the page layout.
5. Click **Print** from the **File** menu to start printing.

**Note:**

*If you close the Job Arranger Lite window before adding all the print data to the Print Project, the print job you are currently working on is canceled. Click **Save** from the **File** menu to save the current job. The extension of the saved files is ".ecl".*

*To open a Print Project, click **Job Arranger Lite** on the printer driver's **Maintenance** tab to open the Job Arranger Lite window. Next, select **Open** from the **File** menu to select the file.*

### Related Information

- ➔ [“Loading Paper” on page 32](#)
- ➔ [“Printing Using Easy Settings” on page 36](#)

## Adjusting the Print Tone

You can adjust the tone used in the print job. These adjustments are not applied to the original data.

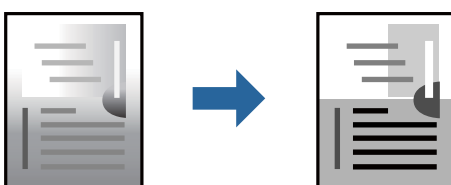

1. On the printer driver's **More Options** tab, select the method of tone correction from the **Tone Correction** setting.
  - Automatic: This setting automatically adjusts the tone to match the paper type and print quality settings.
  - Custom: Click **Advanced**, you can make your own settings.
2. Set the other items on the **Main** and **More Options** tabs as necessary, and then click **OK**.
  - [“Main Tab” on page 37](#)
  - [“More Options Tab” on page 39](#)
3. Click **Print**.

#### Related Information

- ➔ [“Loading Paper” on page 32](#)
- ➔ [“Printing Using Easy Settings” on page 36](#)

## Making Thick Lines Thinner When Printing

If lines are too thick, you can make them thinner when printing.

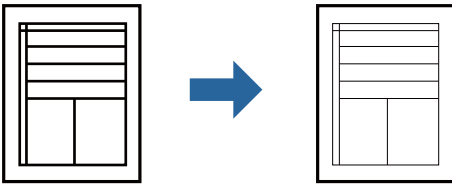

1. On the printer driver's **More Options** tab, click **Image Options** in the **Tone Correction** setting.
2. Select **None** from **Emphasize Thin Lines**, and then click **OK**.
3. Set the other items on the **Main** and **More Options** tabs as necessary, and then click **OK**.
  - [“Main Tab” on page 37](#)
  - [“More Options Tab” on page 39](#)
4. Click **Print**.

#### Related Information

- ➔ [“Loading Paper” on page 32](#)
- ➔ [“Printing Using Easy Settings” on page 36](#)

## Printing to Emphasize Thin Lines

You can thicken thin lines that are too thin to print.

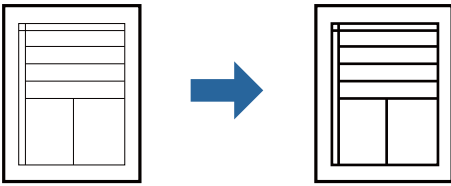

1. On the printer driver's **More Options** tab, click **Image Options** in the **Tone Correction** setting.
2. Select **Emphasize Thin Lines**.
3. Set the other items on the **Main** and **More Options** tabs as necessary, and then click **OK**.  
[“Main Tab” on page 37](#)  
[“More Options Tab” on page 39](#)
4. Click **Print**.

### Related Information

- ➔ [“Loading Paper” on page 32](#)
- ➔ [“Printing Using Easy Settings” on page 36](#)

## Printing Clear Bar Codes

You can print a bar code clearly and make it easy to scan. Only enable this feature if the bar code you printed cannot be scanned.

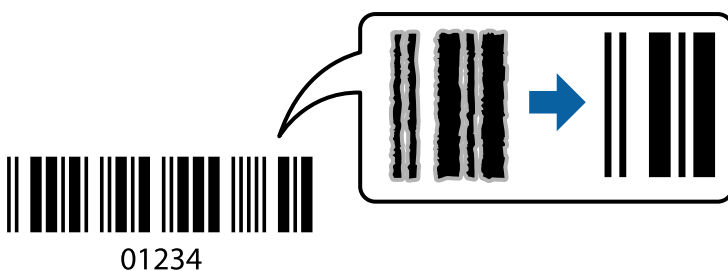

1. On the printer driver's **Maintenance** tab, click **Extended Settings**, and then select **Barcode mode**.
2. Set the other items on the **Main** and **More Options** tabs as necessary, and then click **OK**.  
[“Main Tab” on page 37](#)  
[“More Options Tab” on page 39](#)
3. Click **Print**.

**Note:**

*Deblurring may not always be possible depending on the circumstances.*

### Related Information

- ➔ “Loading Paper” on page 32
- ➔ “Printing Using Easy Settings” on page 36

## Printing with an Overlay

This feature allows you to print documents onto form templates, which you register on your computer in advance.

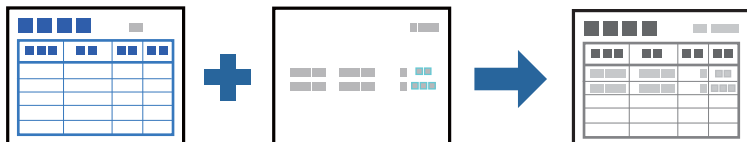

### Note:

The application featured in these instructions is Microsoft WordPad. The actual procedure may differ slightly when printing from other applications.

1. On the printer driver's **More Options** tab, select **Watermark Features** from **Additional Settings**.
2. Select **Form Overlay**, and then click **Settings**.
3. Select one form data in the Form data box, select **Overlay** or **Underlay** in the Layering list, then click **OK**.
4. Click **OK**.
5. Click **Print** to print the document with the form data.

### Related Information

- ➔ “Loading Paper” on page 32
- ➔ “Printing Using Easy Settings” on page 36

## Creating an Overlay

### Note:

- You first need to install EPSON FormOverlayUTL utility to create overlay or underlay data.
- You can download the latest applications from the Epson website.  
<http://www.epson.com>

1. Open the data to be an overlay data using an application.
2. Select **Print** from the File menu, select EPSON FormOverlayUTL, then click **Preferences**.
3. In the **Basic Settings** tab > **Form Overlay** > **Create Overlay Data**, click **More Settings**. The Create Form dialog box appears.

4. Type the form name in the Form data box and its description in the Description box.

**Note:**

*The following 9 characters cannot be used for form names: \ / : \* ? " < > |.*

5. Select **Foreground Document** or **Background Document** to specify whether the overlay will be printed as foreground or background of the document, then click **OK**.

6. Make the appropriate settings for other settings such as paper size, print quality or orientation.

7. Click **OK**.

8. Click **Print** to create the form data.

**Note:**

*To change the settings of the overlay form data you created, after doing steps 1 and 2 and the settings in the **Basic Settings** tab > **Form Overlay** > **Create Overlay Data**, click the **Edit Form**.*

## Printing a Document Using the PostScript Printer Driver (Windows)

A PostScript Printer Driver is a driver that outputs printing commands to a printer using a PostScript Page Description Language.

1. Open the file you want to print.  
Load paper in the printer if it has not already been loaded.
2. Select **Print** or **Print Setup** from the **File** menu
3. Select your printer.

4. Select **Preferences** or **Properties** to access the printer driver window.

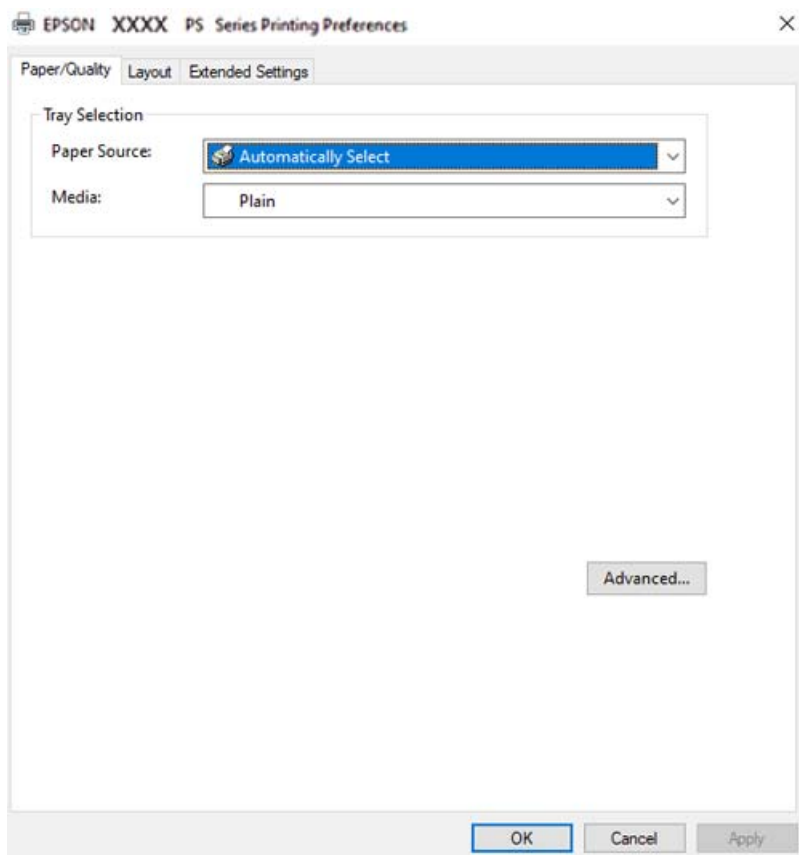

5. Change the settings as necessary.  
See the menu options for the printer driver for details.
6. Click **OK** to close the printer driver for details.
7. Click **Print**.

#### **Related Information**

- ➔ [“Available Paper and Capacities” on page 176](#)
- ➔ [“Loading Paper” on page 32](#)
- ➔ [“Paper/Quality Tab” on page 64](#)
- ➔ [“Layout Tab” on page 65](#)

## **Using an Optional Device with a PostScript Printer Driver**

You need to make settings in the PostScript printer driver to use optional devices.

## Settings

- ❑ Windows 10/Windows Server 2019/Windows Server 2016

Click on the start button, and then select **Windows System > Control Panel > View devices and printers in Hardware and Sound**. Right-click on your printer, or press and hold it and then select **Printer properties**. On the **Device Settings** tab, select the optional device in the **Installable Options** setting.

- ❑ Windows 8.1/Windows 8/Windows Server 2012 R2/Windows Server 2012

Select **Desktop > Settings > Control Panel > View devices and printers in Hardware and Sound**. Right-click on your printer, or press and hold it and then select **Printer properties**. On the **Device Settings** tab, select the optional device in the **Installable Options** setting.

- ❑ Windows 7/Windows Server 2008 R2

Click the start button, and select **Control Panel > View devices and printers in Hardware and Sound**. Right-click on your printer and select **Printer properties**. On the **Device Settings** tab, select the optional device in the **Installable Options** setting.

- ❑ Windows Vista/Windows Server 2008

Click the start button, and select **Control Panel > Printers in Hardware and Sound**. Right-click on your printer and select **Properties**. On the **Device Settings** tab, select the optional device in the **Installable Options** setting.

- ❑ Windows XP/Windows Server 2003 R2/Windows Server 2003

Click the start button, and select **Control Panel > Printers and Other Hardware > Printers and Faxes**. Right-click on your printer and select **Properties**. On the **Device Settings** tab, select the optional device in the **Installable Options** setting.

## Menu Options for the PostScript Printer Driver

Open the print window on an application, select the printer, and then access the printer driver window.

### *Note:*

*Menus vary depending on the option you selected.*

### **Paper/Quality Tab**

#### Tray Selection:

Select the paper source and media.

#### Paper Source:

Select the paper source from which the paper is fed.

Select **Automatically Select** to automatically select the paper source selected in the **Paper Setting** on the printer.

#### Media:

Select the type of paper on which you print. If you select **Unspecified**, printing is performed from the paper source for which the paper type is set to the following in the printer's settings.

Plain, Letterhead, Recycled, Color, Preprinted, Semi-Thick, Thick1, Thick2, Thick3, Labels, Envelope, or Special

However, paper cannot be fed from a paper source for which the paper source is set to off in the printer's **Auto Select Settings**.



### **Layout Tab**

**Orientation:**

Select the orientation you want to use to print.

**Print on Both Sides:**

Allows you to perform 2-sided printing.

**Page Order:**

Select to print from the top or the last page.

**Page Format:**

**Pages per Sheet:**

**Pages per Sheet Layout:**

Allows you to specify the page layout when printing several pages on one sheet.

**Booklet:**

**Booklet Binding Edge:**

Select the binding position for booklet.

**Draw Borders:**

Select this if you want to place a border line for each page when printing several pages on one sheet or when creating a booklet.

### **Extended Settings Tab**

**Job Settings:**

If the printer usage has been restricted by the administrator, printing is available after you register your account on the printer driver. Contact the administrator for your user account.

**Save Access Control settings:**

Allows you to enter a user name and password.

**User Name:**

Enter a user name.

**Password:**

Enter a password.

**Reserve Job Settings:**

Make settings for print jobs stored in the printer's memory.

**Reserve Job Settings:**

Allows you to make settings for **Reserve Job Settings**, **Verify Job**, **Re-Print Job**, or **Confidential Job**.

**Verify Job:**

When printing multiple copies, allows you to print one copy to check the content. To print after the second copy, operate the printer's control panel.

**Re-Print Job:**

Allows you to store the print job in the printer's memory. You can start printing by operating the printer's control panel.

**Confidential Job:**

Select **Confidential Job** and enter the password. The printer will not print until you enter the password on the printer's control panel.

**Password:**

Enter the Confidential Job password.

**User Name:**

Enter a user name.

**Job Name:**

Enter a job name.

### ***Advanced Options***

**Paper/Output:**

Select the paper size and number of copies.

**Paper Size:**

Select the paper size on which you want to print.

**Copy Count:**

Set the number of copies you want to print.

**Graphic:**

Set the following menu items.

**Print Quality:**

Select the print quality you want to use for printing.

**Scaling:**

Allows you to reduce or enlarge the document.

**TrueType Font:**

Sets the font substitute to TrueType Font.

**Document Options:**

**Advanced Printing Features:**

Allows you to make detailed settings for printing features.

#### PostScript Options:

Allows you to make optional settings.

#### Printer Features:

Set the following menu items.

##### Output Tray:

Select which output tray to use for printouts. If you select the face up tray as the output tray, install the optional face up tray.

##### RItech:

You can use the Epson original contour correction (RIT) feature to print jagged lines such as oblique lines and curves smoothly. This is more effective when printing large characters.

##### Toner Save Mode:

You can thin areas other than the outline to save toner. Use this feature when you are not concerned about gradation and print quality, such as when checking the layout.

##### Density:

Set the strength of the density.

##### Output Direction:

Set the paper output direction according to the direction of the paper loaded in the paper feeder.

##### Rotate by 180°:

Rotates the data 180 degrees before printing.

## Printing from a Computer - Mac OS

### Printing Using Easy Settings

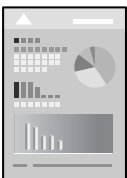

#### **Note:**

*Operations and screens differ depending on the application. See the application's help for details.*

1. Load paper in the printer .  
    [“Loading Paper” on page 32](#)
2. Open the file you want to print.

3. Select **Print** from the **File** menu or another command to access the print dialog.  
If necessary, click **Show Details** or ▼ to expand the print window.
4. Select your printer.
5. Select **Print Settings** from the pop-up menu.

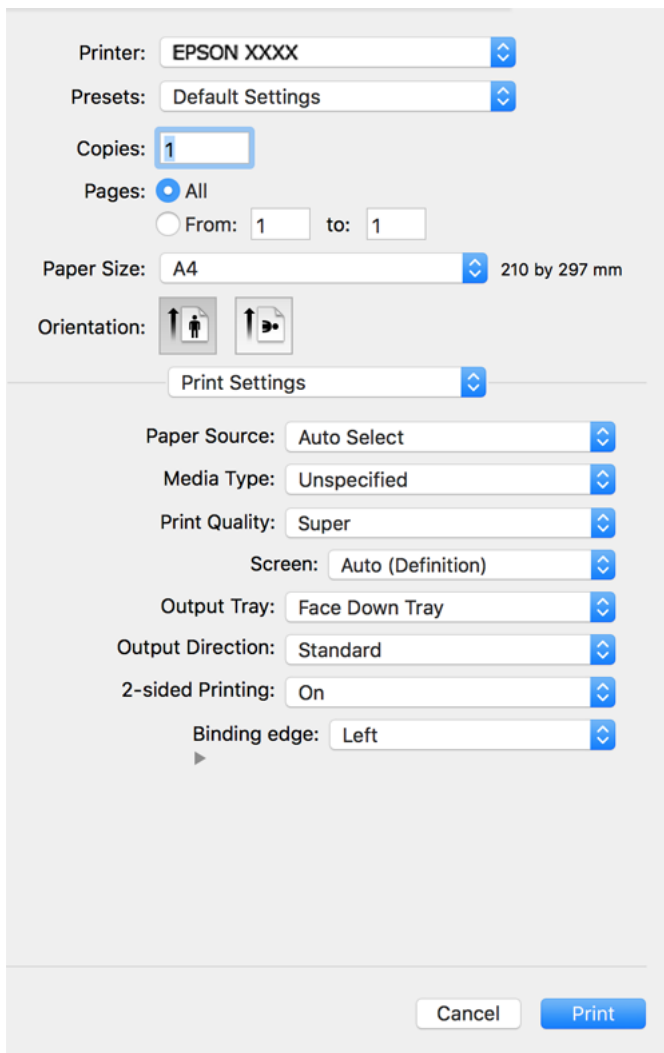

**Note:**

If the **Print Settings** menu is not displayed on macOS Catalina (10.15) or later, macOS High Sierra (10.13), macOS Sierra (10.12), OS X El Capitan (10.11), OS X Yosemite (10.10), OS X Mavericks (10.9), OS X Mountain Lion (10.8), the Epson printer driver has not been installed correctly. Enable it from the following menu.

Select **System Preferences** from the Apple menu > **Printers & Scanners** (or **Print & Scan**, **Print & Fax**), remove the printer, and then add the printer again. See the following to add a printer.

[“Adding the Printer \(for Mac OS Only\)” on page 100](#)

macOS Mojave (10.14) cannot access **Print Settings** in applications made by Apple such as TextEdit.

6. Change the settings as necessary.  
See the menu options for the printer driver for details.

7. Click **Print**.

**Note:**

If you want to cancel printing, on your computer click the printer icon in the **Dock**. Select the job you want to cancel, and then do one of the following. However, you cannot cancel a print job from the computer once it has been completely sent to the printer. In this case, cancel the print job by using the printer's control panel.

- OS X Mountain Lion (10.8) or later

Click  next to the progress meter.

- Mac OS X v10.6.8 to v10.7.x

Click **Delete**.

### Related Information

- ➔ [“Available Paper and Capacities” on page 176](#)
- ➔ [“Menu Options for Print Settings” on page 70](#)

### Menu Options for the Printer Driver

Open the print window in an application, select the printer, and then access the printer driver window.

**Note:**

Menus vary depending on the option you selected.

### Menu Options for Layout

Pages per Sheet:

Select the number of pages to be printed on one sheet.

Layout Direction:

Specify the order in which the pages will be printed.

Border:

Prints a border around the pages.

Reverse page orientation:

Rotates pages 180 degrees before printing. Select this item when printing on paper such as envelopes that are loaded in fixed direction in the printer.

Flip horizontally:

Inverts an image to print as it would appear in a mirror.

### Menu Options for Color Matching

ColorSync/EPSON Color Controls:

Select the method for color adjustment. These options adjust colors between the printer and the computer display to minimize the difference in tone.

### Menu Options for Paper Handling

#### Collate pages:

Prints multi-page documents collated in order and sorted into sets.

#### Pages to Print:

Select to print only odd pages or even pages.

#### Page Order:

Select to print from the top or the last page.

#### Scale to fit paper size:

Prints to fit to the paper size you loaded.

Destination Paper Size:

Select the paper size to print on.

Scale down only:

Select this when you want to reduce the size only if the print data is too large for the paper size loaded in the printer.

### Menu Options for Cover Page

#### Print Cover Page:

Select whether or not to print a cover page. When you want to add a back cover, select **After document**.

#### Cover Page Type:

Select the contents of the cover page.

### Menu Options for Print Settings

#### Paper Source:

Select the paper source from which the paper is fed. Select **Auto Select** to automatically select the paper source selected in the print settings on the printer.

#### Media Type:

Select the type of paper on which you print. If you select **Unspecified**, printing is performed from the paper source for which the paper type is set to the following in the printer's settings.

Plain, Letterhead, Recycled, Color, Preprinted, Semi-thick, Thick paper1, Thick paper2, Thick paper3, Thin Paper, Transparency, Labels, Postcard, Envelope, or Special

However, paper cannot be fed from a paper source for which the paper source is set to off in the printer's **Auto Select Settings**.

#### Print Quality:

Select the print quality you want to use for printing. The options vary depending on the paper type.

#### Screen:

Select whether to prioritize the reproducibility of gradation or increase the resolution.

#### Output Tray:

Select which output tray to use for printouts. If you select the face up tray as the output tray, install the optional face up tray.

#### Output Direction:

Set the paper output direction according to the direction of the paper loaded in the paper feeder.

#### 2-sided Printing:

Prints on both sides of the paper. Select **Booklet** when creating bindings.

#### Binding edge:

You can specify the binding edge.

Click ▼ to set the binding margin. When printing a multi-page document, you can set whether to print from the front or back of the page. When **Booklet** is selected in **2-sided Printing**, you can click ▼ to select the booklet binding method.

### **Menu Options for Color Options**

You can set the gamma and adjust brightness and contrast.

### **Menu Options for Anti-Copy Pattern Settings**

You can print the documents to have hidden letters that appear when photocopied in order to distinguish the original from the copies.

### **Menu Options for Watermark Settings**

You can select a watermark such as the date or label a document as "Confidential", edit the layout and font, and print.

### **Menu Options for Header/Footer Settings**

You can print information such as a user name and printing date in headers or footers.

### **Menu Options for Extension Settings**

You can sharpen printing for thin lines and characters.

### **Menu Options for Confidential Job Settings**

You can set a password for a print job so that it starts printing only after entering the password on the printer's control panel.

## Adding Printing Presets for Easy Printing

If you create your own preset of frequently used print settings on the printer driver, you can print easily by selecting the preset from the list.

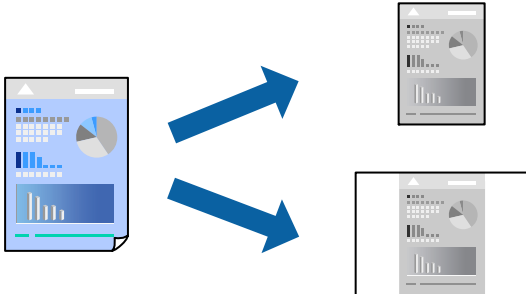

1. Set each item such as **Print Settings** and **Layout (Paper Size, Media Type, and so on)**.
2. Click **Presets** to save the current settings as a preset.
3. Click **OK**.

**Note:**

To delete an added preset, click **Presets > Show Presets**, select the preset name you want to delete from the list, and then delete it.

4. Click **Print**.

The next time you want to print using the same settings, select the registered preset name from the **Presets**.

### Related Information

- ➔ [“Loading Paper” on page 32](#)
- ➔ [“Printing Using Easy Settings” on page 67](#)

## Printing on 2-Sides

You can print on both sides of the paper.

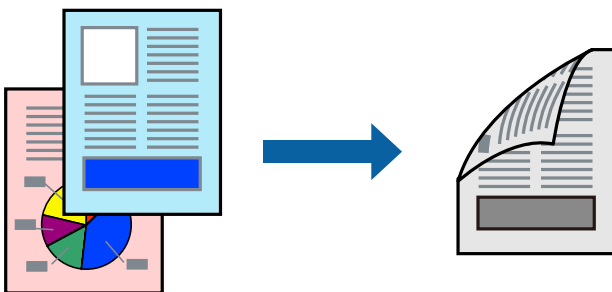

**Note:**

If you do not use paper that is suitable for 2-sided printing, the print quality may decline and paper jams may occur.

[“Paper for Automatic 2-Sided Printing” on page 178](#)

1. Select **Print Settings** from the pop-up menu.



2. Select **On** in **2-sided Printing**.
3. Set the other items as necessary.
4. Click **Print**.

### Related Information

- ➔ [“Available Paper and Capacities” on page 176](#)
- ➔ [“Loading Paper” on page 32](#)
- ➔ [“Printing Using Easy Settings” on page 67](#)

## Printing a Booklet

You can print a booklet that can be created by re-ordering the pages and folding the printout.

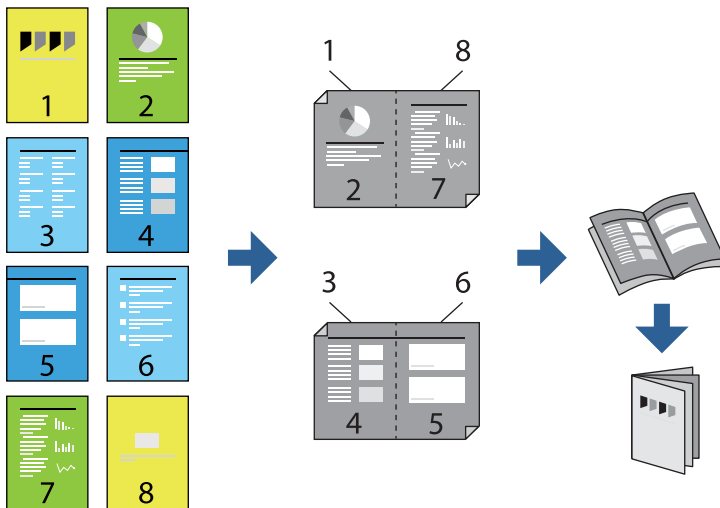

### Note:

*If you do not use paper that is suitable for 2-sided printing, the print quality may decline and paper jams may occur.*

[“Paper for Automatic 2-Sided Printing” on page 178](#)

1. Select **Print Settings** from the pop-up menu.
2. Select **Booklet** in **2-sided Printing**.
3. Set binding edge and click ▼ to set booklet binding.
  - Center Binding:** Use this method when printing a small number of pages that can be stacked and easily folded in half.
  - Side Binding.** Use this method when printing one sheet (four pages) at a time, folding each in half, and then putting them together in one volume.
4. Set the other items as necessary.
5. Click **Print**.

### Related Information

- ➔ [“Available Paper and Capacities” on page 176](#)
- ➔ [“Loading Paper” on page 32](#)
- ➔ [“Printing Using Easy Settings” on page 67](#)

## Printing Several Pages on One Sheet

You can print several pages of data on a single sheet of paper.

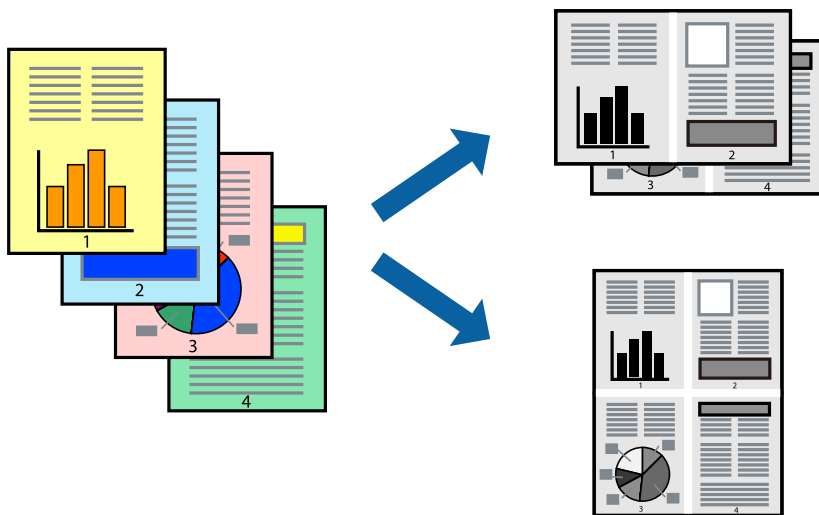

1. Select **Layout** from the pop-up menu.
2. Set the number of pages in **Pages per Sheet**, the **Layout Direction** (page order), and **Border**.  
[“Menu Options for Layout” on page 69](#)
3. Set the other items as necessary.
4. Click **Print**.

### Related Information

- ➔ [“Loading Paper” on page 32](#)
- ➔ [“Printing Using Easy Settings” on page 67](#)

## Printing to Fit the Paper Size

Select the paper size you loaded in the printer as the Destination Paper Size setting.

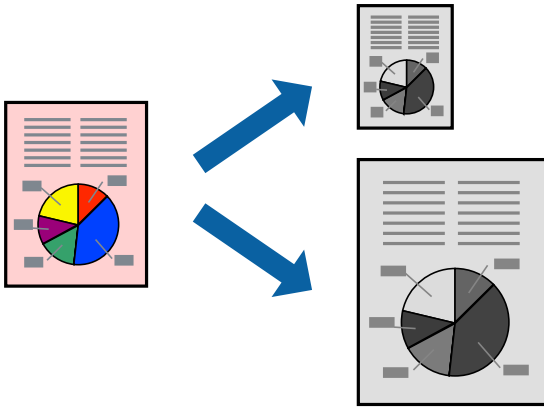

1. Select the size of the paper you set in the application as the **Paper Size** setting.
2. Select **Paper Handling** from the pop-up menu.
3. Select **Scale to fit paper size**.
4. Select the paper size you loaded in the printer as the **Destination Paper Size** setting.
5. Set the other items as necessary.
6. Click **Print**.

### Related Information

- ➔ [“Loading Paper” on page 32](#)
- ➔ [“Printing Using Easy Settings” on page 67](#)

## Printing a Reduced or Enlarged Document at any Magnification

You can reduce or enlarge the size of a document by a specific percentage.



1. Select **Print** from the **File** menu or another command to access the print dialog.
2. Select **Page Setup** from the **File** menu of the application.
3. Select **Printer**, **Paper Size**, enter percentage in **Scale**, and then click **OK**.

**Note:**

Select the paper size you set in the application as the **Paper Size** setting.

4. Set the other items as necessary.
5. Click **Print**.

### Related Information

- ➔ [“Loading Paper” on page 32](#)
- ➔ [“Printing Using Easy Settings” on page 67](#)

## Printing with a Header and Footer

You can print information such as a user name and printing date in headers or footers.

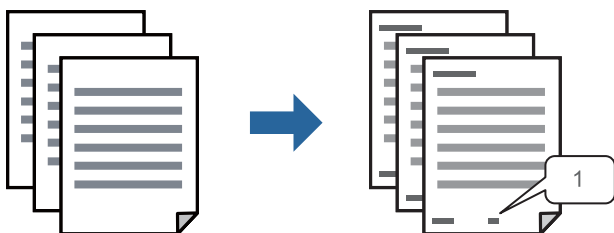

1. Select **Header/Footer Settings** from the pop-up menu.

2. Select an item from the position you want to print.
3. Set the other items as necessary.
4. Click **Print**.

#### Related Information

- ➔ [“Loading Paper” on page 32](#)
- ➔ [“Printing Using Easy Settings” on page 67](#)

## Printing an Anti-Copy Pattern

You can print an anti-copy pattern on your printouts. When printing, the letters themselves are not printed and the entire print is screen-toned lightly. The hidden letters appear when photocopied to easily distinguish the original from the copies.



Anti-Copy Pattern is available under the following conditions:

- Paper Type: Plain, Letterhead, Recycled, Color, Preprinted, Semi-thick, Thick paper1, Thick paper2, Thick paper3, Thin Paper, Transparency, Labels, Postcard, Envelope, or Special
- Quality: Fine

#### **Note:**

*You can also print your own anti-copy pattern.*

1. Select **Anti-Copy Pattern Settings** from the pop-up menu, and then select the type of anti-copy pattern.
2. Edit the layouts and fonts.
3. Set the other items as necessary.
4. Click **Print**.

#### Related Information

- ➔ [“Loading Paper” on page 32](#)
- ➔ [“Printing Using Easy Settings” on page 67](#)

## Printing Password-Protected Files

You can set a password for a print job so that it starts printing only after entering the password on the printer's control panel.

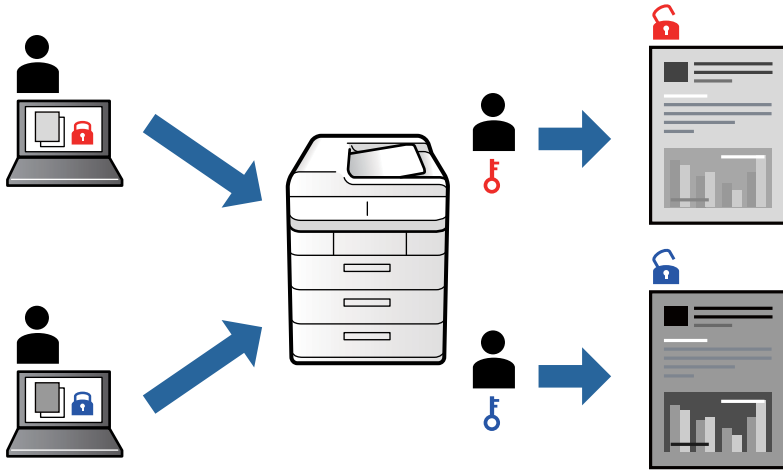

1. Select **Confidential Job Settings** from the pop-up menu.
2. Select **Confidential Job**, and then enter the user name, job name, and password.
3. Set the other items as necessary.
4. Click **Print**.
5. To print the job, select **Print From Internal Memory** on the home screen of the printer's control panel. Select the job you want to print, and then enter the password.

### Related Information

- ➔ [“Loading Paper” on page 32](#)
- ➔ [“Printing Using Easy Settings” on page 67](#)

## Adjusting the Print Tone

You can adjust the tone used in the print job. These adjustments are not applied to the original data.

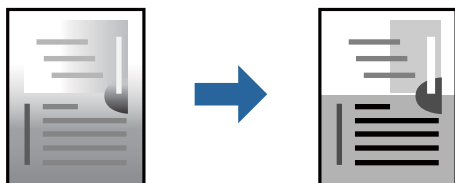

1. Select **Color Options** from the pop-up menu, and then set the gamma, brightness, and contrast.
2. Set the other items as necessary.

3. Click **Print**.

#### Related Information

- ➔ [“Loading Paper” on page 32](#)
- ➔ [“Printing Using Easy Settings” on page 67](#)

## Making Thick Lines Thinner When Printing

If lines are too thick, you can make them thinner when printing.

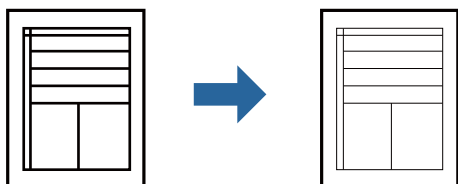

1. Select **Extension Settings** from the pop-up menu.
2. Select **Off** from **Emphasize Thin Lines**.
3. Set the other items as necessary.
4. Click **Print**.

#### Related Information

- ➔ [“Loading Paper” on page 32](#)
- ➔ [“Printing Using Easy Settings” on page 67](#)

## Printing to Emphasize Thin Lines

You can thicken thin lines that are too thin to print.

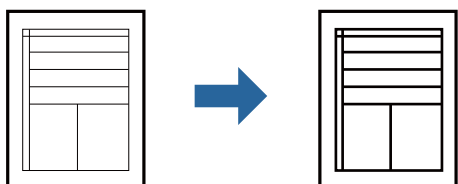

1. Select **Extension Settings** from the pop-up menu.
2. Enable **Emphasize Thin Lines**.
3. Set the other items as necessary.
4. Click **Print**.

## Related Information

- ➔ [“Loading Paper” on page 32](#)
- ➔ [“Printing Using Easy Settings” on page 67](#)

## Printing from the PostScript Printer Driver on Mac OS

A PostScript Printer Driver is a driver that outputs printing commands to a printer using a PostScript Page Description Language.

1. Open the file you want to print.  
Load paper in the printer if it has not already been loaded.
2. Select **Print** or **Print Setup** from the **File** menu.  
If necessary, click **Show Details** or ▼ to expand the print window.
3. Select your printer.
4. Select **Print Features** from the pop-up menu.

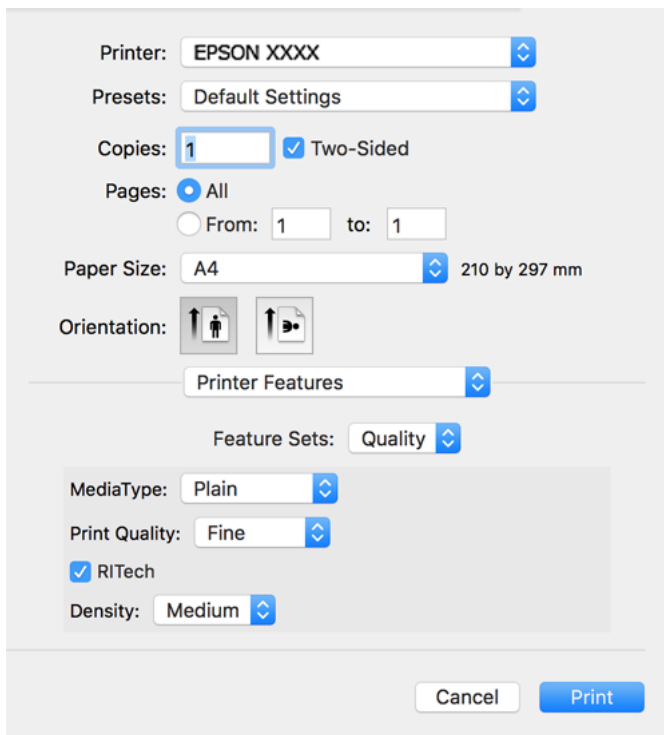

5. Change the settings as necessary.  
See the menu options for the printer driver for details.
6. Click **Print**.



## Related Information

- ➔ [“Available Paper and Capacities” on page 176](#)
- ➔ [“Loading Paper” on page 32](#)
- ➔ [“Menu Options for Printer Features” on page 83](#)

## Using an Optional Device with a PostScript Printer Driver

You need to make settings in the PostScript printer driver to the optional devices.

Select **System Preferences** from the Apple menu > **Printers & Scanners** (or **Print & Scan**, **Print & Fax**), and then select the printer. Click **Options & Supplies** > **Options** (or **Driver**). Makes settings according to the options available.

## Menu Options for the PostScript Printer Driver

Open the print window on an application, select the printer, and then access the printer driver window.

### **Note:**

*Menus vary depending on the option you selected.*

### **Menu Options for Layout**

#### Pages per Sheet:

Select the number of pages to be printed on one sheet.

#### Layout Direction:

Specify the order in which the pages will be printed.

#### Border:

Prints a border around the pages.

#### Two-Sided:

Allows you to perform 2-sided printing.

#### Reverse page orientation:

Rotates pages 180 degrees before printing.

#### Flip horizontally:

Inverts the image so that it prints as it would appear in a mirror.

### **Menu Options for Color Matching**

#### ColorSync/In Printer:

Select the method for color adjustment. These options adjust color between the printer and the computer display to minimize the difference in tone.

### ***Menu Options for Paper Handling***

**Collate pages:**

Prints multi-page documents collated in order and sorted into sets.

**Pages to Print:**

Select to print only odd pages or even pages.

**Page Order:**

Select to print from the top or the last page.

**Scale to fit paper size:**

Prints to fit to the paper size you loaded.

**Destination Paper Size:**

Select the paper size to print on.

**Scale down only:**

Select when reducing the size of the document.

### ***Menu Options for Paper Feed***

Select the paper source from which the paper is fed.

**All Pages From:**

Selecting **Auto Select** selects the paper source that matches the **Paper Setting** on the printer automatically.

**First Page From/Remaining From:**

You can also select the paper source for page.

### ***Menu Options for Cover Page***

**Print Cover Page:**

Select whether or not to print a cover page. When you want to add a back cover, select **After document**.

**Cover Page Type:**

Select the contents of the cover page.

## Menu Options for Printer Features

### Feature Sets:

#### Quality:

##### MediaType:

Select the type of paper on which you print. If you select **Unspecified**, printing is performed from the paper source for which the paper type is set to the following in the printer's settings.

Plain, Letterhead, Recycled, Color, Preprinted, Semi-Thick, Thick1, Thick2, Thick3, Labels, Envelope, Postcard, or Special

However, paper cannot be fed from a paper source for which the paper source is set to off in the printer's **Auto Select Settings**.

##### Print Quality:

Select the print quality you want to use for printing.

##### RTech:

You can use the Epson original contour correction (RIT) feature to print jagged lines such as oblique lines and curves smoothly. This is more effective when printing large characters.

##### Density:

Set the strength of the density.

### Output:

#### Output Tray:

Select which output tray to use for printouts. If you select the face up tray as the output tray, install the optional face up tray.

#### Output Direction:

Set the paper output direction according to the direction of the paper loaded in the paper feeder.

### Others:

#### Toner Save Mode:

You can thin areas other than the outline to save toner. Use this feature when you are not concerned about gradation and print quality, such as when checking the layout.

## Printing Documents from Smart Devices (iOS)

When the wireless router is connected to the same network as the printer, you can print documents from a smart device such as a smartphone or tablet.

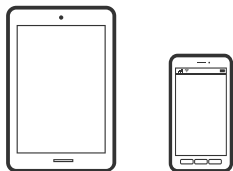

## Printing Documents Using Epson iPrint

**Note:**

*Operations may differ depending on the device.*

1. If Epson iPrint is not installed, install it.  
[“Installing Epson iPrint” on page 184](#)
2. Connect your smart device to the same wireless network as your printer.
3. Start Epson iPrint.
4. Tap **Print Documents** on the home screen.
5. Tap the location of the document you want to print.
6. Select the document, and then tap **Next**.
7. Tap **Print**.

## Printing Documents Using AirPrint

AirPrint enables instant wireless printing from iPhone, iPad, iPod touch, and Mac without the need to install drivers or download software.



**Note:**

*If you disabled paper configuration messages on your printer control panel, you cannot use AirPrint. See the link below to enable the messages, if necessary.*

1. Set up your printer for wireless printing. See the link below.  
<http://epson.sn>
2. Connect your Apple device to the same wireless network that your printer is using.

3. Print from your device to your printer.

**Note:**

For details, see the *AirPrint* page on the Apple website.

### Related Information

➔ [“Cannot Print Even Though a Connection has been Established \(iOS\)” on page 112](#)

## Printing Documents from Smart Devices (Android)

When the wireless router is connected to the same network as the printer, you can print documents from a smart device such as a smartphone or tablet.

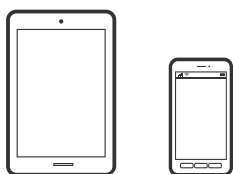

### Printing Documents Using Epson iPrint

**Note:**

Operations may differ depending on the device.

1. If Epson iPrint is not installed, install it.  
[“Installing Epson iPrint” on page 184](#)
2. Connect your smart device to the same wireless network as your printer.
3. Start Epson iPrint.
4. Tap **Print Documents** on the home screen.
5. Tap the location of the document you want to print.
6. Select the document, and then tap **Next**.
7. Tap **Print**.

### Printing Documents Using Epson Print Enabler

You can wirelessly print your documents, emails, photos, and web pages right from your Android phone or tablet (Android v4.4 or later). With a few taps, your Android device will discover an Epson printer that is connected to the same network.

**Note:**

Operations may differ depending on the device.

1. On your Android device, install the Epson Print Enabler plug-in from Google Play.

2. Connect your Android device to the wireless router.
3. Go to **Settings** on your Android device, select **Printing**, and then enable Epson Print Enabler.
4. From an Android application such as Chrome, tap the menu icon and print whatever is on the screen.

**Note:**

If you do not see your printer, tap **All Printers** and select your printer.

## Printing Using Mopria Print Service

Mopria Print Service enables instant wireless printing from Android smart phones or tablets.



1. Install Mopria Print Service from Google Play.
2. Load paper in the printer.
3. Connect your Android device to the same wireless network that your printer is using.
4. Print from your device to your printer.

**Note:**

For more details, access the Mopria Web site at <https://mopria.org>.

### Related Information

➔ [“Loading Paper” on page 32](#)

---

# Printing on Envelopes

## Printing on Envelopes from a Computer (Windows)

1. Load envelopes in the printer.  
[“Loading Envelopes” on page 33](#)
2. Open the file you want to print.
3. Access the printer driver window.
4. Select the envelope size from **Document Size** on the **Main** tab, and then select **Envelope** from **Paper Type**.
5. Set the other items on the **Main** and **More Options** tabs as necessary, and then click **OK**.

6. Click **Print**.

## Printing on Envelopes from a Computer (Mac OS)

1. Load envelopes in the printer.  
[“Loading Envelopes” on page 33](#)
2. Open the file you want to print.
3. Select **Print** from the **File** menu or another command to access the print dialog.
4. Select the size as the **Paper Size** setting.
5. Select **Print Settings** from the pop-up menu.
6. Select **Envelope** as the **Media Type** setting.
7. Set the other items as necessary.
8. Click **Print**.

---

## Printing Web Pages

### Printing Web Pages from Smart Devices

When the wireless router is connected to the same network as the printer, you can operate the printer via the wireless router from your smart device.

**Note:**

*Operations may differ depending on the device.*

1. If Epson iPrint is not installed, install it.  
[“Installing Epson iPrint” on page 184](#)
2. Connect your smart device to the same wireless network as your printer.
3. Open the web page you want to print in your web browser app.
4. Tap **Share** from the menu of the web browser application.
5. Select **iPrint**.
6. Tap **Print**.

## Printing Using a Cloud Service

By using Epson Connect service available on the Internet, you can print from your smartphone, tablet PC, or laptop, anytime and practically anywhere. To use this service, you need to register the user and the printer in Epson Connect.

When the wireless router is connected to the same network as the printer, you can operate the printer via the wireless router from your smart device.

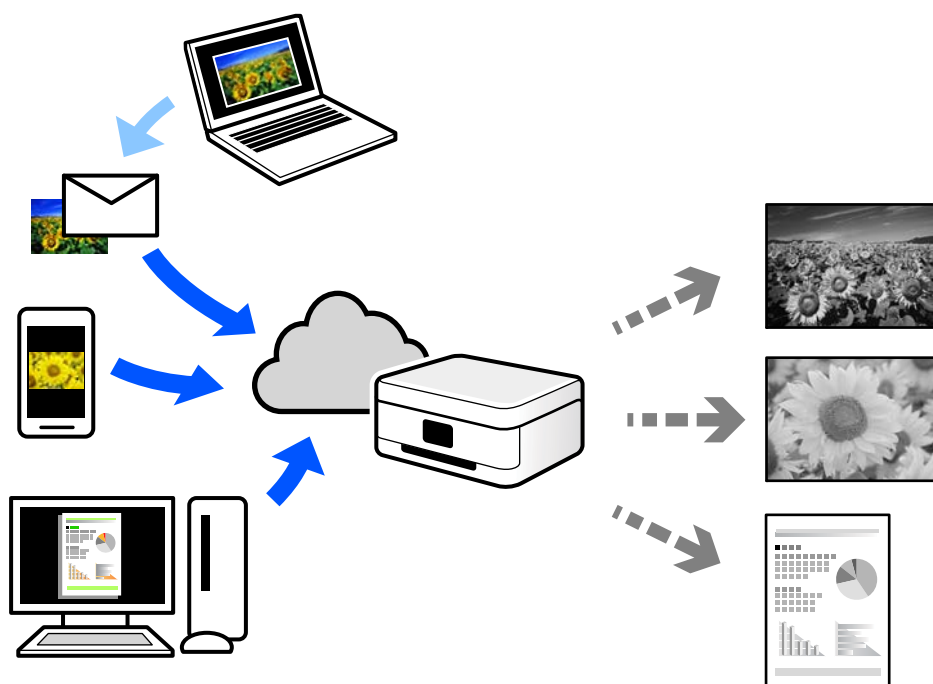

The features available on the Internet are as follows.

Email Print

When you send an email with attachments such as documents or images to an email address assigned to the printer, you can print that email and the attachments from remote locations such as your home or office printer.

Epson iPrint

This Application is for iOS and Android, and allows you to print or scan from a smartphone or tablet. You can print documents, images, and web sites by sending them directly to a printer on the same network.

Remote Print Driver

This is a shared driver supported by Remote Print Driver. When printing using a printer in a remote location, you can print by changing the printer on the usual applications window.

See the Epson Connect web portal for details on how to setup or print.

<https://www.epsonconnect.com/>

<http://www.epsonconnect.eu> (Europe only)

## Registering to Epson Connect Service from the Control Panel

Follow the steps below to register the printer.



1. Select **Settings** on the control panel.
2. Select **General Settings** > **Web Service Settings** > **Epson Connect Services** > **Unregister** to print the registration sheet.
3. Follow the instructions on the registration sheet to register the printer.

---

# Maintaining the Printer

Checking the Consumables Status. . . . .	91
Cleaning the Paper Path when There are Paper Feeding Problems. . . . .	91
Cleaning Inside the Printer. . . . .	92
Cleaning the Printer. . . . .	96
Installing or Uninstalling Applications Separately. . . . .	96
Moving and Transporting the Printer. . . . .	104
Checking the Printer Status (Status Sheet Print). . . . .	106

## Checking the Consumables Status

You can check the status of consumables from the printer's control panel. Select  on the home screen, and then select **Replacement Parts**.

To select an item, use the ▲ ▼ ◀ ▶ buttons, and then press the OK button.

**Note:**

- You can also check the status of consumables on the Epson Status Monitor if it is installed.
-  is displayed on the LCD screen when the consumable is nearing the end of its service life. You can continue to print but prepare a new consumable item before it reaches the end of its service life.

## Cleaning the Paper Path when There are Paper Feeding Problems

The printer needs only minimal cleaning to keep it in good condition.

 **Caution:**

- Do not touch inside the printer except when instructed to do so in the printer's documentation. Otherwise, it may result in fire or electric shock.
- Do not use any kind of combustible gases such as air dusters or dust sprays inside or around this product the printer. Otherwise it may result in fire or explosion.

 **Important:**

- Do not use volatile chemicals such as benzene, thinner, or alcohol to clean the printer. Otherwise, the chemicals may damage the printer's components and the case.
- Do not get the printer wet.
- Do not clean the printer with a hard brush or a hard cloth. Otherwise, the printer may be damaged.

## Cleaning the Pickup Rollers for the Paper Tray

See the animations displayed on the printer's LCD screen to clean the pickup rollers for the paper tray.

Select , and then select **Troubleshooting > Paper feeding problem > Paper Tray**.

Select **Finish** to close the animation screen.

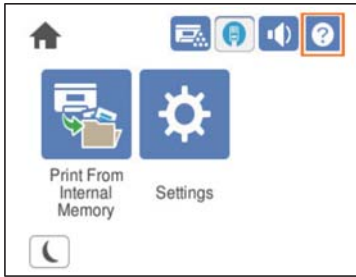

## Cleaning the Pickup Rollers for the Paper Cassettes

See the animations displayed on the printer's LCD screen to clean the pickup rollers for the paper cassettes.

Select , and then select **Troubleshooting** > **Paper feeding problem** > **Paper Cassette**.

Select **Finish** to close the animation screen.

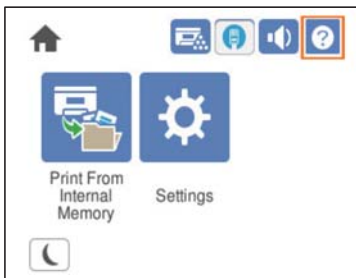

---

## Cleaning Inside the Printer

The printer needs only minimal cleaning to keep it in good condition.



**Caution:**

- Do not touch inside the printer except when instructed to do so in the printer's documentation. Otherwise, it may result in fire or electric shock.
- Do not use any kind of combustible gases such as air dusters or dust sprays inside or around this product the printer. Otherwise it may result in fire or explosion.

**⚠ Caution:**

- ❑ Never touch the areas inside the printer that are marked with caution labels. The inside is very hot and high temperature may cause burns.

There are sharp edges around the transfer roller that could injure your fingers.

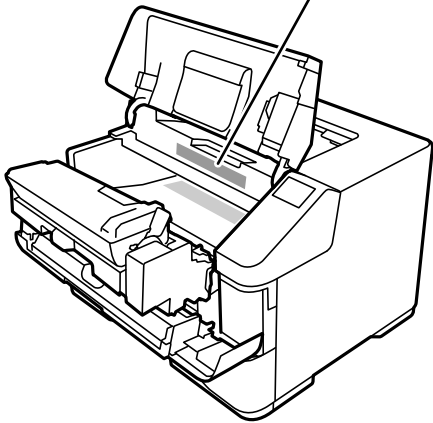

**! Important:**

- ❑ Do not use volatile chemicals such as benzene, thinner, or alcohol to clean the printer. Otherwise, the chemicals may damage the printer's components and the case.
- ❑ Do not get the printer wet.
- ❑ Do not clean the printer with a hard brush or a hard cloth. Otherwise, the printer may be damaged.

1. Turn the printer off and unplug the power cord.
2. Open the printer cover (A), then the front cover (F).

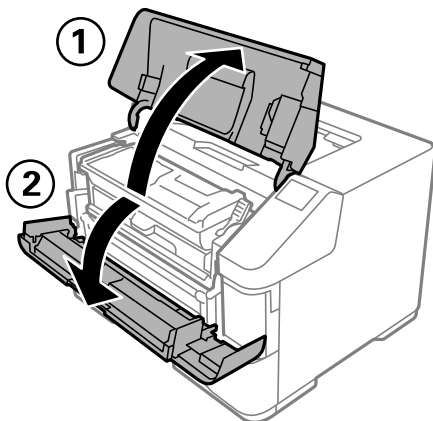

3. Lift the handle D to unlock the developer unit. Pull the handle D obliquely up to draw out the developer unit.

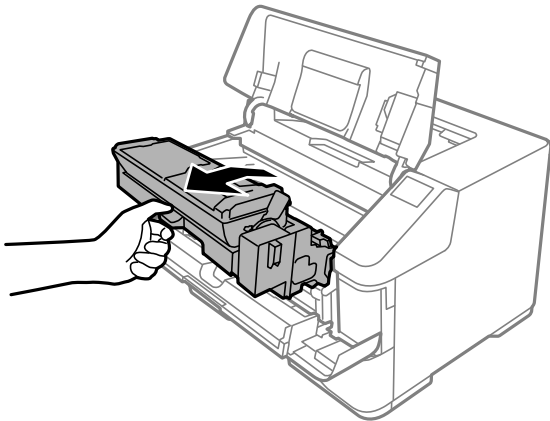

4. Gently wipe the metallic roller inside with a soft and dry cloth to remove the grime and paper particles.



**Important:**

*Do not touch the transfer roller, which is black, to avoid damaging it.*

5. Push the handle D until the developer unit locks.

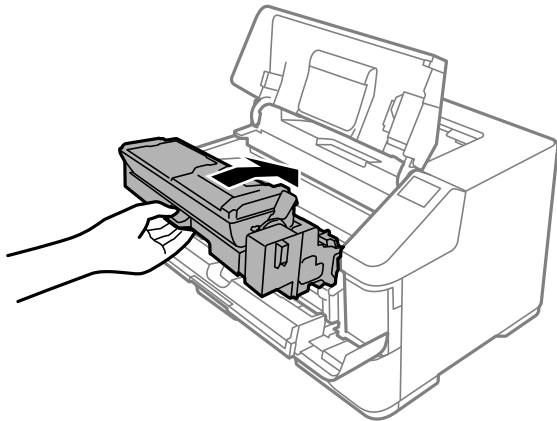

6. Close the front cover (F), then the printer cover (A).

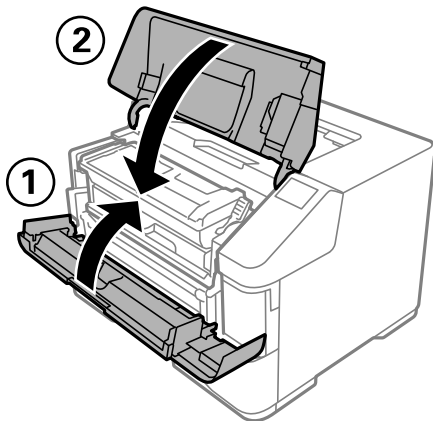

7. Open the waste toner collector cover (E), and wipe the vent holes with a soft, dry cloth to remove dust and dirt.

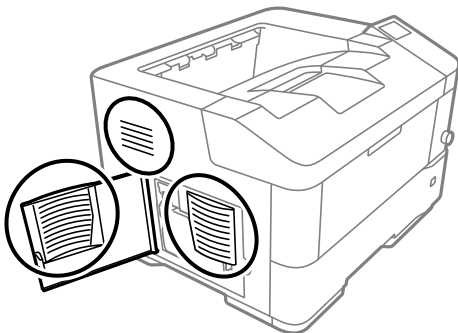

8. Close the waste toner collector cover (E).

9. Wipe the vent holes on the right side of the printer with a soft, dry cloth to remove dust and dirt.

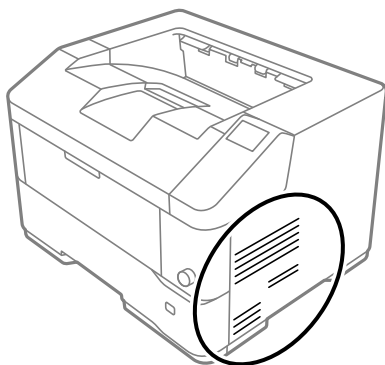

---

## Cleaning the Printer

If the printer's outer case is dirty or dusty, turn off the printer and clean it with a soft, clean, and moist cloth. If you cannot remove the dirt, try cleaning with a soft, clean, and moist cloth moistened with a mild detergent.

**!** *Important:*

- Do not use volatile chemicals such as benzine, thinner, or alcohol to clean the printer. Otherwise, the chemicals may damage the printer's components and the case.*
- Do not get the printer wet.*
- Do not clean the printer with a hard brush or a hard cloth. Otherwise, the printer may be damaged.*

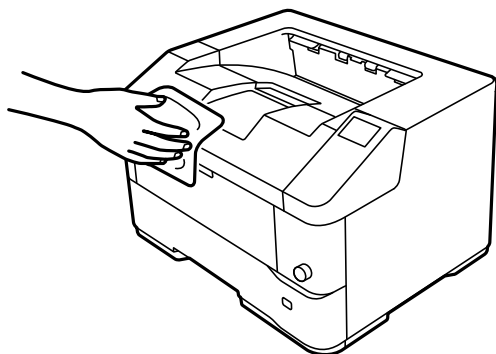

---

## Installing or Uninstalling Applications Separately

Connect your computer to the network and install the latest version of applications from the website. Log in to your computer as an administrator. Enter the administrator password if the computer prompts you.

### Installing the Applications Separately

**Note:**

*When reinstalling an application, you need to uninstall it first.*



1. Make sure the printer and the computer are available for communication, and the printer is connected to the Internet.
2. Start EPSON Software Updater.

The screenshot is an example on Windows.

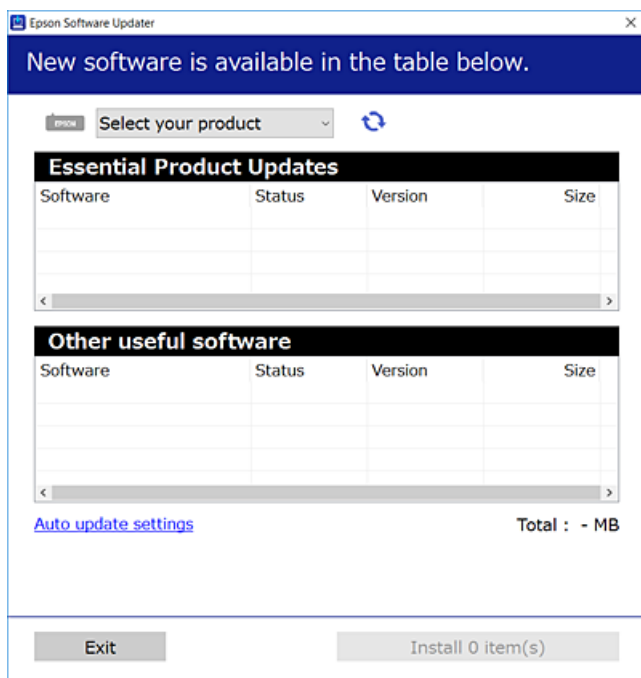

3. For Windows, select your printer, and then click  to check for the latest available applications.
4. Select the items you want to install or update, and then click the install button.



**Important:**

*Do not turn off or unplug the printer until the update is complete. Doing so may result in malfunction of the printer.*

**Note:**

- You can download the latest applications from the Epson website.  
<http://www.epson.com>
- If you use Windows Server operating systems, you cannot use Epson Software Updater. Download the latest applications from the Epson website.

**Related Information**

- ➔ “Application for Updating Software and Firmware (EPSON Software Updater)” on page 185
- ➔ “Uninstalling Applications” on page 100

**Checking if a genuine Epson printer driver is installed - Windows**

You can check if a genuine Epson printer driver is installed on your computer by using one of the following methods.

Select **Control Panel > View devices and printers (Printers, Printers and Faxes)**, and then do the following to open the print server properties window.

- ❑ Windows 10/Windows 8.1/Windows 8/Windows 7/Windows Server 2019/Windows Server 2016/Windows Server 2012 R2/Windows Server 2012/Windows Server 2008 R2

Click the printer icon, and then click **Print server properties** at the top of the window.

- ❑ Windows Vista/Windows Server 2008

Right-click on the **Printers** folder, and then click **Run as administrator > Server Properties**.

- ❑ Windows XP/Windows Server 2003 R2/Windows Server 2003

From the **File** menu, select **Server Properties**.

Click the **Driver** tab. If your printer name is displayed in the list, a genuine Epson printer driver is installed on your computer.

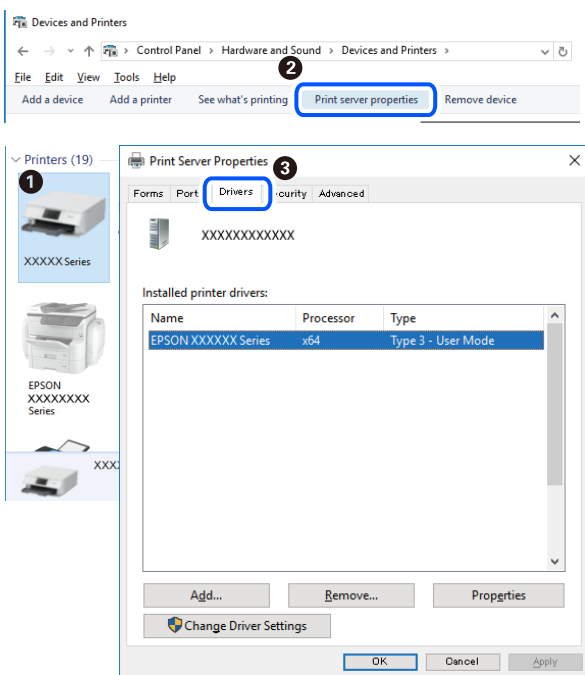

## Related Information

➔ [“Installing the Applications Separately” on page 96](#)

## Checking if a genuine Epson printer driver is installed - Mac OS

You can check if a genuine Epson printer driver is installed on your computer by using one of the following methods.

Select **System Preferences** from the Apple menu > **Printers & Scanners** (or **Print & Scan, Print & Fax**), and then select the printer. Click **Options & Supplies**, and if the **Options** tab and **Utility** tab are displayed on the window, a genuine Epson printer driver is installed on your computer.



#### Related Information

➔ [“Installing the Applications Separately”](#) on page 96

## Installing a PostScript Printer Driver

### Installing a PostScript Printer Driver - Windows

1. Start the installation process from one of the following options.
  - Use the software disc supplied with the printer.**  
Insert the software disc into the computer, access the following folder path, and then run SETUP64.EXE (or SETUP.EXE).  
Driver\PostScript\WINX64 (or WINX86)\SETUP\SETUP64.EXE ( or SETUP.EXE)
  - Download from the website.**  
Access your printer page from the following website, download the PostScript printer driver, and then run the execution file.  
<http://www.epson.eu/Support> (Europe)  
<http://support.epson.net/> (outside Europe)
2. Select your printer.
3. Follow the on-screen instructions.

4. Select the connection method from the network connection or USB connection.
  - For network connection.**  
A list of available printers in the same network is displayed.  
Select the printer you want to use.
  - For USB connection.**  
Follow the on-screen instructions to connect the printer to the computer.
5. Follow the on-screen instructions to install the PostScript printer driver.

## Installing a PostScript Printer Driver - Mac OS

Download the printer driver from the Epson Support website, and then install it.

<http://www.epson.eu/Support> (Europe)

<http://support.epson.net/> (outside Europe)

You need the IP address of the printer while installing the printer driver.

Select the network icon on the printer's home screen, and then select the active connection method to confirm the printer's IP address.

## Adding the Printer (for Mac OS Only)

1. Select **System Preferences** from the Apple menu > **Printers & Scanners** (or **Print & Scan, Print & Fax**).
2. Click **+**, and then select **Add Other Printer or Scanner**.
3. Select your printer, and then select your printer from the **Use**.
4. Click **Add**.
  - Note:**
  - If your printer is not listed, check that it is correctly connected to the computer and that the printer is on.*
  - For a USB, IP, or Bonjour connection, set the optional paper cassette unit manually after adding the printer.*

## Uninstalling Applications

Log in to your computer as an administrator. Enter the administrator password if the computer prompts you.

## Uninstalling Applications - Windows

1. Press the  button to turn off the printer.
2. Quit all running applications.

3. Open **Control Panel**:

- Windows 10/Windows Server 2019/Windows Server 2016

Click on the start button, and then select **Windows System > Control Panel**.

- Windows 8.1/Windows 8/Windows Server 2012 R2/Windows Server 2012

Select **Desktop > Settings > Control Panel**.

- Windows 7/Windows Vista/Windows XP/Windows Server 2008 R2/Windows Server 2008/Windows Server 2003 R2/Windows Server 2003

Click the start button and select **Control Panel**.

4. Open **Uninstall a program** (or **Add or Remove Programs**):

- Windows 10/Windows 8.1/Windows 8/Windows 7/Windows Vista/Windows Server 2019/Windows Server 2016/Windows Server 2012 R2/Windows Server 2012/Windows Server 2008 R2/Windows Server 2008

Select **Uninstall a program** in **Programs**.

- Windows XP/Windows Server 2003 R2/Windows Server 2003

Click **Add or Remove Programs**.

5. Select the application you want to uninstall.

You cannot uninstall the printer driver if there is any print jobs. Delete or wait to be printed the jobs before uninstalling.

6. Uninstall the applications:

- Windows 10/Windows 8.1/Windows 8/Windows 7/Windows Vista/Windows Server 2019/Windows Server 2016/Windows Server 2012 R2/Windows Server 2012/Windows Server 2008 R2/Windows Server 2008

Click **Uninstall/Change** or **Uninstall**.

- Windows XP/Windows Server 2003 R2/Windows Server 2003

Click **Change/Remove** or **Remove**.

**Note:**

*If the **User Account Control** window is displayed, click **Continue**.*

7. Follow the on-screen instructions.

## Uninstalling Applications - Mac OS

1. Download the Uninstaller using EPSON Software Updater.

Once you have downloaded the Uninstaller, you do not need to download it again each time you uninstall the application.

2. Press the  button to turn off the printer.

3. To uninstall the printer driver, select **System Preferences** from the Apple menu > **Printers & Scanners** (or **Print & Scan, Print & Fax**), and then remove the printer from the enabled printers list.

4. Quit all running applications.

5. Select **Go > Applications > Epson Software > Uninstaller**.
6. Select the application you want to uninstall, and then click **Uninstall**.



**Important:**

*The Uninstaller removes all drivers for Epson printers on the computer. If you use multiple Epson printers and you only want to delete some drivers, delete all of them first, and then install the necessary printer driver again.*

**Note:**

*If you cannot find the application you want to uninstall in the application list, you cannot uninstall using the Uninstaller. In this situation, select **Go > Applications > Epson Software**, select the application you want to uninstall, and then drag it to the trash icon.*

**Related Information**

➔ “Application for Updating Software and Firmware (EPSON Software Updater)” on page 185

## Updating Applications and Firmware

You may be able to clear certain problems and improve or add functions by updating the applications and the firmware. Make sure you use the latest version of the applications and firmware.

1. Make sure that the printer and the computer are connected, and the computer is connected to the internet.
2. Start EPSON Software Updater, and update the applications or the firmware.



**Important:**

*Do not turn off the computer or the printer until the update is complete; otherwise, the printer may malfunction.*

**Note:**

*If you cannot find the application you want to update in the list, you cannot update using the EPSON Software Updater. Check for the latest versions of the applications from your local Epson website.*

<http://www.epson.com>

**Related Information**

➔ “Application for Updating Software and Firmware (EPSON Software Updater)” on page 185

## Updating the Printer's Firmware using the Control Panel

If the printer can be connected to the Internet, you can update the printer's firmware using the control panel. You can also set the printer to regularly check for firmware updates and notify you if any are available.

You cannot change settings that have been locked by your administrator.

1. Select **Settings** on the home screen.

To select an item, use the ▲ ▼ ◀ ▶ buttons, and then press the OK button.

2. Select **General Settings > System Administration > Firmware Update > Update**.

**Note:**

Select **Notification > On** to set the printer to regularly check for available firmware updates.

3. Select **Start Checking**.

The printer starts searching for available updates.

4. If a message is displayed on the LCD screen informing you that a firmware update is available, follow the on-screen instructions to start the update.



**Important:**

- ❑ Do not turn off or unplug the printer until the update is complete; otherwise, the printer may malfunction.
- ❑ If the firmware update is not completed or is unsuccessful, the printer does not start up normally and "Recovery Mode" is displayed on the LCD screen the next time the printer is turned on. In this situation, you need to update the firmware again using a computer. Connect the printer to the computer with a USB cable. While "Recovery Mode" is displayed on the printer, you cannot update the firmware over a network connection. On the computer, access your local Epson website, and then download the latest printer firmware. See the instructions on the website for the next steps.

## Updating Firmware Using Web Config

When the printer can connect to the Internet, you can update the firmware from Web Config.

1. Access Web Config and select the **Device Management** tab > **Firmware Update**.
2. Click **Start**, and then follow the on-screen instructions.

The firmware confirmation starts, and the firmware information is displayed if the updated firmware exists.

**Note:**

You can also update the firmware using *Epson Device Admin*. You can visually confirm the firmware information on the device list. It is useful when you want to update multiple devices' firmware. See the *Epson Device Admin* guide or help for more details.

### Related Information

➔ ["Application for Configuring Printer Operations \(Web Config\)" on page 221](#)

## Updating Firmware without Connecting to the Internet

You can download the device's firmware from Epson website on the computer, and then connect the device and the computer by USB cable to update the firmware. If you cannot update over the network, try this method.

1. Access Epson website and download the firmware.
2. Connect the computer that contains the downloaded firmware to the printer by USB cable.
3. Double-click the downloaded .exe file.  
Epson Firmware Updater starts.

4. Follow the on-screen instructions.

## Moving and Transporting the Printer

 **Caution:**

- When carrying the printer, lift it using a stable position. Lifting the printer using an unstable position may result in injury.
- Because this printer is heavy, it should always be carried by two or more people when unpacking and transporting.
- When lifting the printer, place your hands in the positions shown below. If you lift the printer holding other positions, the printer may fall or you may trap your fingers when placing the printer.

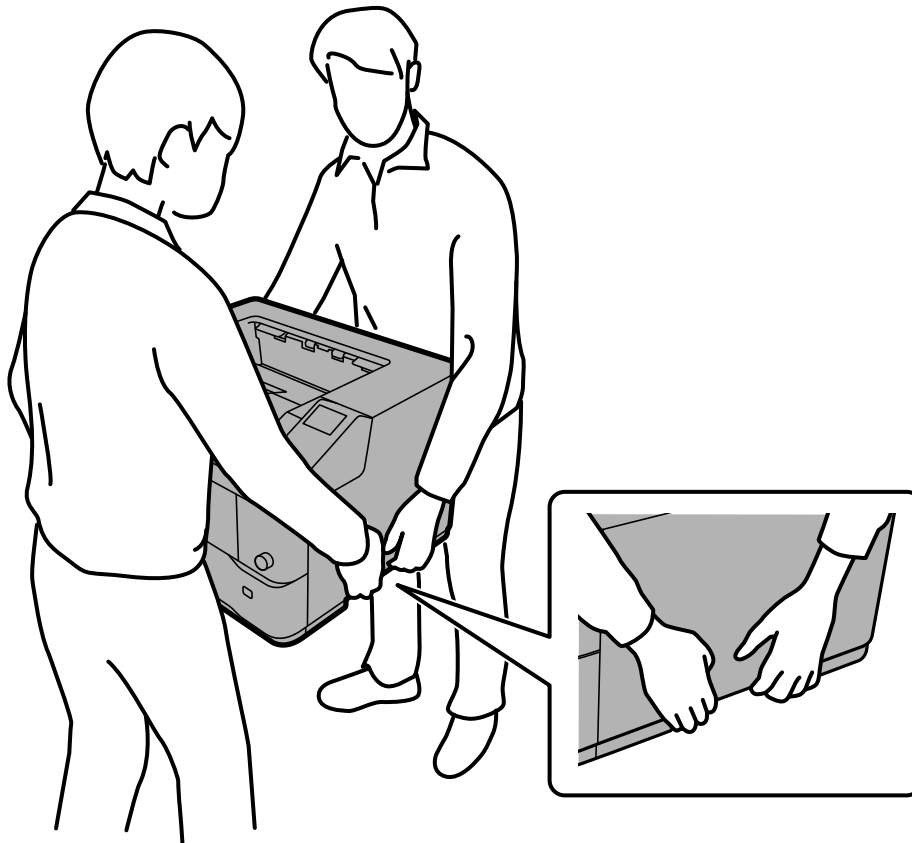

- Do not touch the projections on the bottom of the printer that are for connecting an optional paper cassette.
- When carrying the printer, do not tilt it more than 10 degrees; otherwise the printer may fall.
- When you put the printer on a stand with casters, make sure you lock the casters. Otherwise, the stand may move unexpectedly and cause an injury.

## Transporting the Printer for Short Distances

Make sure the printer is turned off and the operation panel is unlit, and then unplug the power plug from the outlet and remove the following items from the printer.



- Power cord
- Interface cables
- Loaded paper
- Installed optional paper cassette units

 **Important:**

*When moving the printer, always keep it horizontal and avoid subjecting it to shocks.*

### When lifting the printer to move it

Separate the printer and the optional paper cassette unit.

 **Important:**

*Unlock the fixture on the back of the printer to separate the printer and the optional paper cassette unit. If you lift the printer without unlocking the fixture, the fixture may be damaged and the optional paper cassette unit may fall.*

### When moving the printer on casters

Unlock the stopper for the casters. Avoid steps when moving the printer to prevent it from being subjected to shocks.

### Related Information

- ➔ [“Installing the Paper Cassette Units to the Printer” on page 152](#)
- ➔ [“Installing the Face up Tray” on page 157](#)

## Transporting the Printer

When you need to transport the printer, follow the steps below to pack it. The printer should be packed in the same status as when it was purchased to prevent it from being subjected to vibrations or shocks.

1. Turn off the printer by pressing the  button and then unplug the power cord.
2. Remove all of the paper from the printer.
3. Disconnect all cables such as USB cables and remove installed options such as paper cassette units.  
See the steps for installing options and remove them in reverse order.
4. Pack the printer in its box, using the protective materials.

 **Important:**

*To avoid condensation after transporting the printer from a cool to a warm environment, allow the printer to warm up to room temperature before use.*

### Related Information

- ➔ [“Installing the Paper Cassette Units to the Printer” on page 152](#)

- ➔ [“Installing the Printer Stand to the Paper Cassette Unit” on page 148](#)
- ➔ [“Installing the Face up Tray” on page 157](#)

---

## Checking the Printer Status (Status Sheet Print)

You can check the settings and the status of the printer.

1. Select **Settings** on the home screen.  
To select an item, use the ▲ ▼ ◀▶ buttons, and then press the OK button.
2. Select **Printer Status/Print** > **Print Status Sheet** > **Configuration Status Sheet**.
3. Check the message, and then print the status sheet.

---

# Solving Problems

Cannot Print. . . . .	108
Paper Gets Jammed. . . . .	123
A Message is Displayed on the LCD Screen. . . . .	125
It is Time to Replace Consumables. . . . .	126
Print Quality is Poor. . . . .	128
Cannot Solve Problem. . . . .	133

# Cannot Print

---

## Problem Solving

Read this section if you cannot print as expected or if there are problems when printing. See the following for solutions to some common problems.

### ■ Is the printer turned on?

#### Solutions

- Make sure that the printer is turned on.
- Make sure that the power cord is correctly connected.
- ➔ [“The Printer Does Not Turn On or Off” on page 120](#)
- ➔ [“Cannot Solve Problem” on page 133](#)

### ■ Is the printer itself working properly?

#### Solutions

- If an error message is displayed on the LCD screen, check the error.
- Print a status sheet and use it to check if the printer itself can print properly.
- ➔ [“A Message is Displayed on the LCD Screen” on page 125](#)
- ➔ [“Checking the Printer Status \(Status Sheet Print\)” on page 106](#)

### ■ Is any paper jammed in the printer?

#### Solutions

- If paper is jammed in the printer, it cannot start printing. Remove the jammed paper from the printer.
- ➔ [“Paper Gets Jammed” on page 123](#)

### ■ Has print data been sent correctly?

#### Solutions

- Make sure there is no print data standing by from a previous job.
- Check the printer driver to make sure the printer is not offline.
- ➔ [“The printer is pending or offline.” on page 109](#)
- ➔ [“There is a problem with the software or data.” on page 109](#)
- ➔ [“Cannot Print Even Though a Connection has been Established \(Windows\)” on page 109](#)
- ➔ [“Cannot Print Even Though a Connection has been Established \(Mac OS\)” on page 111](#)

### ■ Are you having problems connecting to the computer?

#### Solutions

- Make sure that the cables are properly connected for all connections.
- Make sure that the network device and USB hub are operating normally.

- ❑ If you have a Wi-Fi connection, make sure that the Wi-Fi connection settings are correct.
- ➔ [“Cannot Print Using a USB Connection” on page 112](#)
- ➔ [“There is a problem with the USB hub.” on page 113](#)
- ➔ [“Something is wrong with the network devices for Wi-Fi connection.” on page 113](#)
- ➔ [“Cannot Print Using a Network Connection” on page 113](#)

## The Application or Printer Driver do not Work Properly

The following causes can be considered.

### Cannot Print Even Though a Connection has been Established (Windows)

The following causes can be considered.

#### ■ The printer is pending or offline.

##### Solutions

Click **Print Queue** on the printer driver's **Maintenance** tab.

If the printer is offline or pending, clear the offline or pending setting from the **Printer** menu.

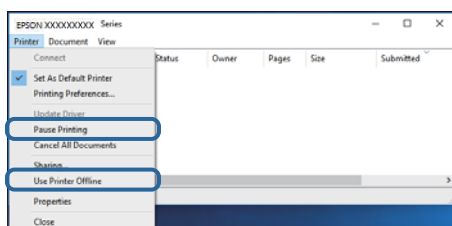

#### ■ There is a problem with the software or data.

##### Solutions

- ❑ Make sure that a genuine Epson printer driver (EPSON XXXXX) is installed. If a genuine Epson printer driver is not installed, the available functions are limited. We recommend using a genuine Epson printer driver.
  - ❑ If you are printing a large data size image, the computer may run out of memory. Print the image at a lower resolution or a smaller size.
  - ❑ If you are printing a large data size image, the data may not be processed depending on the CPU or memory of the computer. Try the following solutions.
    - ❑ Install more memory in your computer if you can.
    - ❑ Set the printer driver's **Quality** setting to **Fast** (300dpi).
    - ❑ Set interfaces that you are not using to disabled.
  - ❑ If you have tried all of the solutions and have not solved the problem, try uninstalling and then reinstalling the printer driver
- ➔ [“Checking if a genuine Epson printer driver is installed - Windows” on page 97](#)
  - ➔ [“Checking if a genuine Epson printer driver is installed - Mac OS” on page 98](#)
  - ➔ [“Installing or Uninstalling Applications Separately” on page 96](#)

**There is a problem with the printer's status.**

**Solutions**

Click **EPSON Status Monitor** on the printer driver's **Maintenance** tab, and then check the printer status. You need to install EPSON Status Monitor to enable this feature. You can download it from the Epson website.

**There is still a job waiting to be printed.**

**Solutions**

Click **Print Queue** on the printer driver's **Maintenance** tab. If unnecessary data remains, select **Cancel all documents** from the **Printer** menu.

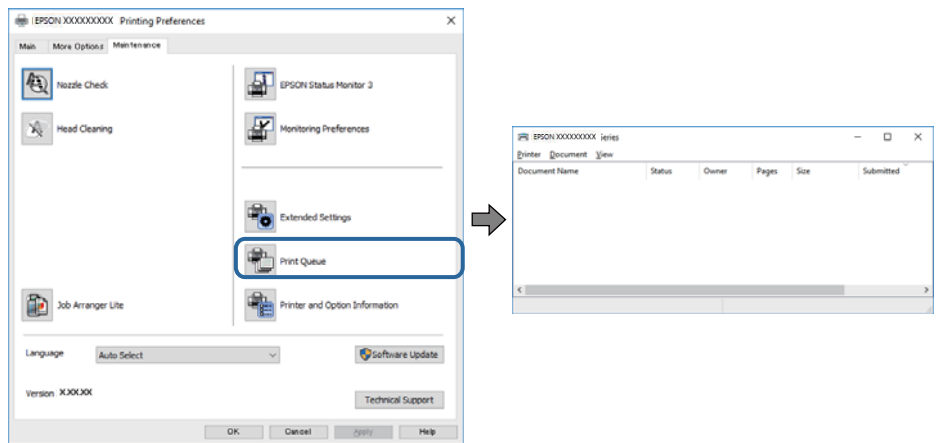

**The printer is not selected as the default printer.**

**Solutions**

Right-click the printer icon in **Control Panel > View devices and printers** (or **Printers, Printers and Faxes**) and click **Set as default printer**.

**Note:**

*If there are multiple printer icons, see the following to select the correct printer.*

Example)

USB connection: EPSON XXXX Series

Network connection: EPSON XXXX Series (network)

If you install the printer driver multiple times, copies of the printer driver may be created. If copies such as "EPSON XXXX Series (copy 1)" are created, right-click the copied driver icon, and then click **Remove Device**.

**The printer port is not set correctly.**

**Solutions**

Click **Print Queue** on the printer driver's **Maintenance** tab.

Make sure the printer port is set correctly as shown below in **Property > Port** from the **Printer** menu.

USB connection: **USBXXX**, Network connection: **EpsonNet Print Port**

If you cannot change the port, select **Run as administrator** on the **Printer** menu. If **Run as administrator** is not displayed, contact your system administrator.

### ■ The selected printer is wrong.

#### Solutions

The printer name may have been changed. Contact the system administrator for the correct printer name, and then select the printer with that name.

### Printer Does Not Print While Using PostScript Printer Driver (Windows)

The following causes can be considered.

### ■ The Printing Language setting needs to be changed.

#### Solutions

Set the **Printing Language** setting to **Auto** or **PS** on the control panel.

### ■ A large number of jobs have been sent.

#### Solutions

In Windows, if a large number of jobs are sent, the printer may not print. Select **Print directly to the printer** on the **Advanced** tab in the printer properties.

### Cannot Print Even Though a Connection has been Established (Mac OS)

The following causes can be considered.

### ■ There is a problem with the software or data.

#### Solutions

- Make sure that a genuine Epson printer driver (EPSON XXXXX) is installed. If a genuine Epson printer driver is not installed, the available functions are limited. We recommend using a genuine Epson printer driver.
  - If you are printing a large data size image, the computer may run out of memory. Print the image at a lower resolution or a smaller size.
  - If you are printing a large data size image, the data may not be processed depending on the CPU or memory of the computer. Try the following solutions.
    - Install more memory in your computer if you can.
    - Set the printer driver's **Quality** setting to **Fast** (300dpi).
    - Set interfaces that you are not using to disabled.
  - If you have tried all of the solutions and have not solved the problem, try uninstalling and then reinstalling the printer driver
- ➔ [“Checking if a genuine Epson printer driver is installed - Windows” on page 97](#)
- ➔ [“Checking if a genuine Epson printer driver is installed - Mac OS” on page 98](#)
- ➔ [“Installing or Uninstalling Applications Separately” on page 96](#)

### ■ There is a problem with the status of the printer.

#### Solutions

Make sure the printer status is not **Pause**.

Select **System Preferences** from the **Apple** menu > **Printers & Scanners** (or **Print & Scan, Print & Fax**), and then double-click the printer. If the printer is paused, click **Resume**.

■ **User feature restrictions are enabled for the printer.**

**Solutions**

The printer may not print when the user feature restriction is enabled. Contact your printer administrator.

■ **The selected printer is wrong.**

**Solutions**

The printer name may have been changed. Contact the system administrator for the correct printer name, and then select the printer with that name.

## **Printer Does Not Print While Using PostScript Printer Driver (Mac OS)**

■ **The Printing Language setting needs to be changed.**

**Solutions**

Set the **Printing Language** setting to **Auto** or **PS** on the control panel.

## **Cannot Print Even Though a Connection has been Established (iOS)**

The following causes can be considered.

■ **Paper Setup Auto Display is disabled.**

**Solutions**

Enable **Paper Setup Auto Display** in the following menu.

**Settings > General Settings > Printer Settings > Paper Source Settings > Paper Setup Auto Display**

■ **AirPrint is disabled.**

**Solutions**

Enable the AirPrint setting on Web Config.

➔ [“Application for Configuring Printer Operations \(Web Config\)”](#) on page 221

## **Cannot Connect to the Printer**

The following issues could be causing the problem.

## **Cannot Print Using a USB Connection**

The following causes can be considered.



### ■ The USB cable is not plugged into the electrical outlet correctly.

#### Solutions

Connect the USB cable securely to the printer and the computer.

### ■ There is a problem with the USB hub.

#### Solutions

If you are using a USB hub, try to connect the printer directly to the computer.

### ■ There is a problem with the USB cable or the USB inlet.

#### Solutions

If the USB cable cannot be recognized, change the port, or change the USB cable.

### ■ The printer is connected to a SuperSpeed USB port.

#### Solutions

If you connect the printer to a SuperSpeed USB port using a USB 2.0 cable, a communication error may occur on some computers. In this case, re-connect the printer using one of the following methods.

- Use a USB 3.0 cable.
- Connect to a Hi-Speed USB port on the computer.
- Connect to a SuperSpeed USB port other than the port that generated the communication error.

## Cannot Print Using a Network Connection

The following issues could be causing the problem.

#### Note:

*Even if your printer is only using a wired connection, check the Wi-Fi environment if your computer or smart device is connected to the network by Wi-Fi.*

### ■ The IP address is incorrectly assigned.

#### Solutions

If the IP address assigned to the printer is 169.254.XXX.XXX, and the subnet mask is 255.255.0.0, the IP address may not be assigned correctly.

Select **Settings > General Settings > Network Settings > Advanced** on the printer's control panel, and then check the IP address and the subnet mask assigned to the printer.

Restart the wireless router or reset the network settings for the printer.

➔ [“Re-setting the Network Connection” on page 136](#)

### ■ Something is wrong with the network devices for Wi-Fi connection.

#### Solutions

Turn off the devices you want to connect to the network. Wait for about 10 seconds, and then turn on the devices in the following order; wireless router, computer or smart device, and then printer. Move the

printer and computer or smart device closer to the wireless router to help with radio wave communication, and then try to make network settings again.

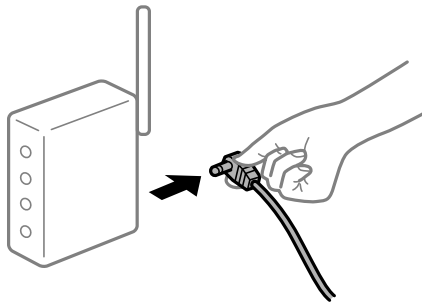

■ **The printer is not connected to the network.**

**Solutions**

Select **Settings > General Settings > Network Settings > Connection Check**, and then print the network connection report. If the report shows that the network connection failed, check the network connection report and then follow the printed solutions.

➔ [“Printing a Network Connection Report” on page 138](#)

■ **When changing the wireless router, the settings do not match the new router.**

**Solutions**

Make the connection settings again so that they match the new wireless router.

➔ [“When Replacing the Wireless Router” on page 136](#)

■ **Devices cannot receive signals from the wireless router because they are too far apart.**

**Solutions**

After moving the computer or the smart device closer to the wireless router, turn off the wireless router, and then turn it back on.

■ **A privacy separator on the wireless router is available.**

**Solutions**

Most wireless routers have a separator function that blocks communication between devices within the same SSID. If you cannot communicate between the printer and the computer or smart device even if they are connected to the same network, disable the separator function on the wireless router. See the manual provided with the wireless router for details.

■ **There is a problem with the network settings on the computer.**

**Solutions**

Try accessing any website from your computer to make sure that your computer's network settings are correct. If you cannot access any website, there is a problem on the computer.

Check the network connection of the computer. See the documentation provided with the computer for details.

## The printer has been connected by Ethernet using devices that support IEEE802.3az (Energy Efficient Ethernet).

### Solutions

When you connect the printer by Ethernet using devices that support IEEE802.3az (Energy Efficient Ethernet), the following problems may occur depending on the hub or router that you are using.

- Connection becomes unstable, the printer is connected and disconnected again and again.
- Cannot connect to the printer.
- The communication speed becomes slow.

Follow the steps below to disable IEEE802.3az for the printer and then connect.

1. Remove the Ethernet cable connected to the computer and the printer.
  2. When IEEE802.3az for the computer is enabled, disable it.  
See the documentation provided with the computer for details.
  3. Connect the computer and the printer with an Ethernet cable directly.
  4. On the printer, print a network connection report.  
[“Printing a Network Connection Report” on page 138](#)
  5. Check the printer's IP address on the network connection report.
  6. On the computer, access Web Config.  
Launch a Web browser, and then enter the printer's IP address.  
[“Running Web Config on a Web Browser” on page 221](#)
  7. Select the **Network** tab > **Wired LAN**.
  8. Select **OFF** for **IEEE 802.3az**.
  9. Click **Next**.
  10. Click **OK**.
  11. Remove the Ethernet cable connected to the computer and the printer.
  12. If you disabled IEEE802.3az for the computer in step 2, enable it.
  13. Connect the Ethernet cables that you removed in step 1 to the computer and the printer.
- If the problem still occurs, devices other than the printer may be causing the problem.

## Paper Does Not Feed or Eject Correctly

### No Paper Feeds

The following causes can be considered.

#### ■ Unsupported paper is being used.

##### Solutions

Use paper supported by this printer.

➔ [“Available Paper and Capacities” on page 176](#)

➔ [“Unavailable Paper Types” on page 178](#)

#### ■ Paper handling is inappropriate.

##### Solutions

Follow paper handling precautions.

➔ [“Paper Handling Precautions” on page 31](#)

#### ■ Too many sheets are loaded in the printer.

##### Solutions

Do not load more than the maximum number of sheets specified for the paper.

➔ [“Available Paper and Capacities” on page 176](#)

#### ■ Paper cassette is not inserted correctly.

##### Solutions

Insert the standard paper cassette and optional paper cassette correctly. Make sure that the edge guide is in the correct position. After inserting the paper cassette, select **Settings > Printer Status/Print > Print Status Sheet > Configuration Status Sheet** to print the configuration status sheet, and then make sure that the paper cassette and paper size are recognized correctly.

#### ■ The paper settings on the printer are incorrect.

##### Solutions

Make sure the paper size and paper type settings match the actual paper size and paper type loaded in the printer.

➔ [“Paper Size and Type Settings” on page 32](#)

#### ■ The size of paper in the cassette does not match the setting on the paper size setting dial.

##### Solutions

Match size of paper in the cassette to the setting on the paper size setting dial.

■ **The paper source setting is not correct.**

**Solutions**

Select the correct paper source in the printer driver.

■ **Paper slips when paper dust adheres to the roller.**

**Solutions**

Clean the roller.

➔ [“Cleaning the Paper Path when There are Paper Feeding Problems” on page 91](#)

## **Paper Feeds at a Slant**

The following causes can be considered.

■ **Unsupported paper is being used.**

**Solutions**

Use paper supported by this printer.

➔ [“Available Paper and Capacities” on page 176](#)

➔ [“Unavailable Paper Types” on page 178](#)

■ **Paper handling is inappropriate.**

**Solutions**

Follow paper handling precautions.

➔ [“Paper Handling Precautions” on page 31](#)

■ **The paper is loaded incorrectly.**

**Solutions**

Load paper in the correct direction, and slide the edge guide against the edge of the paper.

➔ [“Loading Paper” on page 32](#)

■ **Too many sheets are loaded in the printer.**

**Solutions**

Do not load more than the maximum number of sheets specified for the paper.

➔ [“Available Paper and Capacities” on page 176](#)

■ **Paper cassette is not inserted correctly.**

**Solutions**

Insert the standard paper cassette and optional paper cassette correctly. Make sure that the edge guide is in the correct position. After inserting the paper cassette, select **Settings > Printer Status/Print > Print Status Sheet > Configuration Status Sheet** to print the configuration status sheet, and then make sure that the paper cassette and paper size are recognized correctly.

■ **The paper settings on the printer are incorrect.**

**Solutions**

Make sure the paper size and paper type settings match the actual paper size and paper type loaded in the printer.

➔ [“Paper Size and Type Settings” on page 32](#)

■ **The size of paper in the cassette does not match the setting on the paper size setting dial.**

**Solutions**

Match size of paper in the cassette to the setting on the paper size setting dial.

■ **The paper source setting is not correct.**

**Solutions**

Select the correct paper source in the printer driver.

■ **Paper slips when paper dust adheres to the roller.**

**Solutions**

Clean the roller.

➔ [“Cleaning the Paper Path when There are Paper Feeding Problems” on page 91](#)

## **Several Sheets of Paper are Fed at a Time**

The following causes can be considered.

■ **Unsupported paper is being used.**

**Solutions**

Use paper supported by this printer.

➔ [“Available Paper and Capacities” on page 176](#)

➔ [“Unavailable Paper Types” on page 178](#)

■ **Paper handling is inappropriate.**

**Solutions**

Follow paper handling precautions.

➔ [“Paper Handling Precautions” on page 31](#)

■ **The paper is loaded incorrectly.**

**Solutions**

Load paper in the correct direction, and slide the edge guide against the edge of the paper.

➔ [“Loading Paper” on page 32](#)

■ **The paper is curled.**

**Solutions**

Load the paper upside down.

■ **The paper is moist or damp.**

**Solutions**

Load new paper.

■ **Static electricity is causing sheets of paper to stick to each other.**

**Solutions**

Fan the paper before loading. For special paper, load one sheet of paper at a time.

■ **Too many sheets are loaded in the printer.**

**Solutions**

Do not load more than the maximum number of sheets specified for the paper.

➔ [“Available Paper and Capacities” on page 176](#)

■ **Paper cassette is not inserted correctly.**

**Solutions**

Insert the standard paper cassette and optional paper cassette correctly. Make sure that the edge guide is in the correct position. After inserting the paper cassette, select **Settings > Printer Status/Print > Print Status Sheet > Configuration Status Sheet** to print the configuration status sheet, and then make sure that the paper cassette and paper size are recognized correctly.

■ **The paper settings on the printer are incorrect.**

**Solutions**

Make sure the paper size and paper type settings match the actual paper size and paper type loaded in the printer.

➔ [“Paper Size and Type Settings” on page 32](#)

■ **The size of paper in the cassette does not match the setting on the paper size setting dial.**

**Solutions**

Match size of paper in the cassette to the setting on the paper size setting dial.

■ **The paper source setting is not correct.**

**Solutions**

Select the correct paper source in the printer driver.

## Cannot Eject Paper Alternately in Portrait and Landscape Orientation

### ■ Paper loading or paper setting is wrong.

#### Solutions

To eject paper alternately, the printer prints on paper fed alternately from two paper sources. Therefore, this feature is only available for A4 paper that can be loaded in horizontal and landscape orientations. Select the paper size and direction on the control panel, and then select the setting for ejecting alternately in the printer driver.

➔ [“Ejecting Paper in Portrait or Landscape Alternately” on page 34](#)

## Cannot Operate the Printer as Expected

### The Printer Does Not Turn On or Off

#### Power Does Not Turn On

The following causes can be considered.

### ■ The power cord is not plugged in properly to the electrical outlet.

#### Solutions

Make sure the power cord is securely plugged in.

### ■ The button was not pressed for long enough.

#### Solutions

Hold down the  button for longer than five seconds.

#### Power Does Not Turn Off

### ■ The button was not pressed for long enough.

#### Solutions

Hold down the  button for a little longer. If you still cannot turn off the printer, unplug the power cord.

### Power Turns Off Automatically

### ■ Power Off If Disconnected feature is enabled.

#### Solutions

Select **Settings > General Settings > Basic Settings**, and then disable the **Power Off If Disconnected** setting.

#### Note:

*This feature may not be available depending on your region.*



## Operations are Slow

### Printing Is Too Slow

The following causes can be considered.

#### ■ Unnecessary applications are running.

##### Solutions

Close any unnecessary applications on your computer or smart device.

#### ■ The printer is in sleep mode.

##### Solutions

When the printer is in sleep mode it needs to warm up before you can start printing; therefore it may take some time before paper is ejected.

#### ■ The printer is performing adjustments.

##### Solutions

To maintain optimum print quality, the printer may stop printing to automatically adjust some internal features. The printer automatically restarts printing when adjusting is complete.

#### ■ A setting that takes some time to process is selected such as thick paper.

##### Solutions

When printing on plain paper, set the paper type setting to **Plain paper**.

#### ■ The printer is cooling the fuser unit.

##### Solutions

When continuously printing on narrow paper, the printer needs to cool the fuser unit to prevent it from overheating which may slow down printing. Wait until printing is complete.

#### ■ The print data size is too large.

##### Solutions

If you are printing a large data size image, the data may not be processed depending on the CPU or memory of the computer. Try the following solutions.

- Install more memory in your computer if you can.
- Set the printer driver's **Quality** setting to **Fast** (300dpi).
- Set interfaces that you are not using to disabled.

#### ■ The printer is refreshing the drum.

##### Solutions

Wait until the printer has finished. If you set **Drum Heater** to **On** in **Settings >General Settings > System Administration > Printer Adjust Menu**, it reduces the frequency of drum refresh.

## ■ Reducing printing time.

### Solutions

If you make the following settings, it may reduce the printing time.

- ❑ Select **Settings > General Settings > Basic Settings**, and then set **Quick Sleep to Off**.
- ❑ Select **Settings > General Settings > Basic Settings**, and then set **Sleep Timer** to maximum value.
- ❑ Select **Settings > General Settings > System Administration > Printer Adjust Menu**, and then set **Fuser Temperature** to **Keep**.

## Printing Is Too Slow While Using PostScript Printer Driver

### ■ The Print quality setting is high.

#### Solutions

Set the **Print Quality** setting to **Fast** in the printer driver.

## LCD Screen Gets Dark

### ■ The printer is in sleep mode.

#### Solutions

Press the  button on the control panel to return the LCD screen to its former state.

## The Root Certificate Needs to be Updated

### ■ The root certificate has expired.

#### Solutions

Run Web Config, and then update the root certificate.

## Cannot Cancel Printing from a Computer Running Mac OS X v10.6.8

### ■ There is a problem with your AirPrint setup.

#### Solutions

Run Web Config, and then select **Port9100** as the **Top Priority Protocol** setting in **AirPrint Setup**. Select **System Preferences** from the Apple menu > **Printers & Scanners** (or **Print & Scan, Print & Fax**), remove the printer, and then add the printer again.

➔ [“Application for Configuring Printer Operations \(Web Config\)” on page 221](#)

## Forgot Your Password

### ■ You need help from service personnel.

#### Solutions

If you forget the administrator's password, contact Epson support.

## Communication error occurs while using Epson Status Monitor.

The following causes can be considered.

### ■ IPP is used for communication protocols.

#### Solutions

Since IPP cannot monitor network printers, a communication error may occur, but printing finishes normally. To prevent this error from being displayed, clear **Monitor the printing status** on the **Notice Settings** screen.

### ■ Redirect printing is performed using the remote desktop feature. (Windows XP/Windows Vista)

#### Solutions

A communication error is displayed, but printing finishes normally.

---

## Paper Gets Jammed

Check the error displayed on the control panel and follow the instructions to remove the jammed paper including any torn pieces. The LCD screen displays an animation that shows you how to remove jammed paper. Next, select **OK** to clear the error.

**Caution:**

Never touch the areas inside the printer that are marked with caution labels. The inside is very hot and high temperature may cause burns. There are sharp edges around the transfer roller that could injure your fingers.

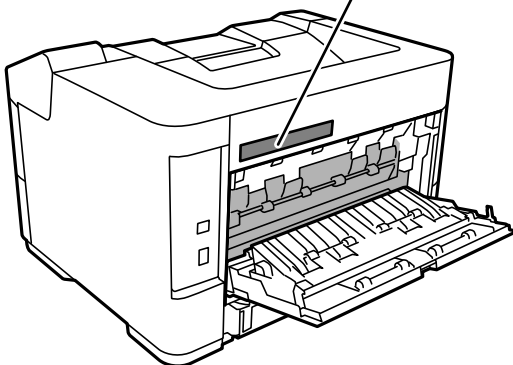
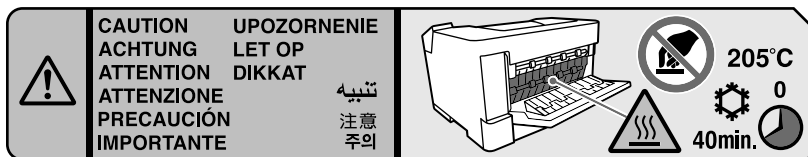
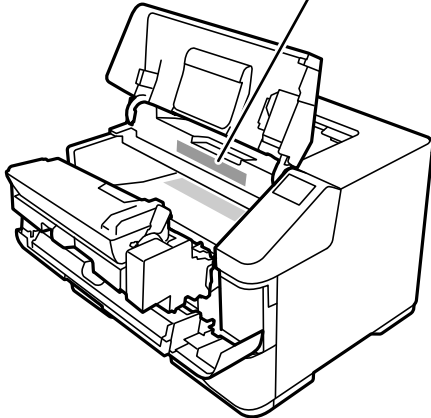
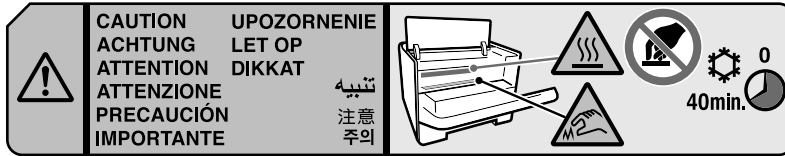

Note the following when removing jammed paper.

- Remove the jammed paper carefully with both hands to prevent the paper from tearing. Removing the paper with too much force may tear the paper making it difficult to remove which may cause another paper jam.
- If the paper does tear, remove all of the paper including any torn pieces.
- If you cannot remove the torn paper or cannot remove paper that is jammed in a part of the printer not explained in this manual, contact Epson support.

## Preventing Paper Jams

Check the following if paper jams occur frequently.

- ❑ Use the paper supported by this printer.  
“Available Paper and Capacities” on page 176
- ❑ Follow paper handling precautions.  
“Paper Handling Precautions” on page 31
- ❑ Load paper in the correct direction, and slide the edge guide against the edge of the paper.  
“Loading Paper” on page 32
- ❑ Do not load more than the maximum number of sheets specified for paper.
- ❑ Load one sheet of paper at a time if you have loaded several sheets of paper.
- ❑ For A4 or A5 size paper, change the loading direction to portrait or horizontal. If you load paper in the portrait direction, print speed may be slower.
- ❑ Make sure the paper size and paper type settings match the actual paper size and paper type loaded in the printer.

## A Message is Displayed on the LCD Screen

If an error message is displayed on the LCD screen, follow the on-screen instructions or the solutions below to solve the problem.

Error Messages	Solutions
The combination of the IP address and the subnet mask is invalid. See your documentation for more details.	Enter the correct IP address or default gateway. Contact your network administrator for assistance.
To use cloud services, update the root certificate from the Epson Web Config utility.	Run Web Config, and then update the root certificate.
Check that the printer driver is installed on the computer and that the port settings for the printer are correct.	Make sure the printer port is selected correctly in <b>Property &gt; Port</b> from the <b>Printer</b> menu as follows. Select " <b>USBXXX</b> " for a USB connection, or " <b>EpsonNet Print Port</b> " for a network connection.
Check that the printer driver is installed on the computer and that the USB port settings for the printer are correct.	
Paper Setup Auto Display is set to Off. Some features may not be available. For details, see your documentation.	If <b>Paper Setup Auto Display</b> is disabled, you cannot use AirPrint.
Printer Error Turn on the printer again. See your documentation for more details.	Turn off the power, wait for a few minutes, and then turn it on again. If the error message is still displayed, contact Epson support.
Printer error. Contact Epson Support. Non-printing features are available.	The printer may be damaged. Contact Epson support or an authorised Epson service provider to request repairs. However, non-printing features are available.
Paper out in XX.	Load paper, and then insert the paper cassette all the way.
Cannot print because XX is out of order. You can print from another cassette.	Turn the power off and on again, and then reinsert the paper cassette. If the error message is still displayed, contact Epson support or an authorised Epson service provider to request repairs.

Error Messages	Solutions
Maintenance Roller in XX is nearing the end of its service life.	The maintenance rollers need to be replaced periodically. Paper is not fed correctly from the paper cassette when it is time for replacement. Contact Epson support or an authorized Epson service provider to request replacement of the maintenance rollers.
Maintenance roller in the XX is at the end of its service life. For details, see your documentation.	Contact Epson support or an authorized Epson service provider to request replacement of the maintenance rollers for the paper cassette.
Toner Cartridge is at the end of its service life. Replace Waste Toner Collector first, then Toner Cartridge.	Replace with a new toner cartridge and waste toner collector. If the error message is still displayed, make sure that the waste toner collector is inserted until it locks into place.
Recovery Mode Update Firmware	The printer has started in recovery mode because the firmware update failed. Follow the steps below to try to update the firmware again.  1. Connect the computer and the printer with a USB cable. (During recovery mode, you cannot update the firmware over a network connection.)  2. Visit your local Epson website for further instructions.

## It is Time to Replace Consumables

### Precautions when Handling Consumables

Always observe the following handling precautions when replacing consumables or maintenance parts.



**Warning:**

Be sure to read the handling precautions linked below as well as the following precautions.

[“Handling the Consumable Products and Maintenance Parts” on page 18](#)



**Caution:**

When replacing consumables, make sure you protect your surroundings by laying down sheets of paper to prevent toner from getting on your surroundings or clothes.



**Important:**

This product is designed to provide the best print quality when using genuine toner. Other products not manufactured by Epson may cause damage or reduce print quality that is not covered by Epson’s warranties, and under certain circumstances, may cause erratic printer behavior. Epson shall not be liable for any damages or problems arising from the use of consumable products not manufactured or approved by Epson.

**Note:**

Store consumables under the following conditions.

- Store consumables out of direct sunlight. Store them as they were packed at the time of purchase in a location that is not subject to condensation and within a temperature of 0 to 35°C and a humidity of 15 to 80%.
- Do not store consumables standing on their ends or tilting.

## Related Information

➔ [“Consumable Products Information” on page 179](#)

# It is Time to Replace the Toner Cartridge and the Waste Toner Collector

## Handling Precautions when Replacing the Toner Cartridge

Note the following points when replacing the toner cartridges.



### **Important:**

- Do not refill the toner cartridge. Normal printing may not be possible.
- If toner gets on your skin or clothes, wash it off with soap and water immediately.
- Although the toner is harmless to humans, it can be difficult to remove if it is left on your skin or clothes.
- After moving the toner cartridges from a cool to a warm environment, leave it unopened to warm up at room temperature for at least one hour before using it.

## Handling Precautions when Replacing the Waste Toner Collector

Note the following points when replacing the waste toner collector.

- Do not reuse the toner in the waste toner collector.
- Be careful not to spill any toner. Although the toner is harmless to humans, if toner gets on your skin or clothes, wash it off with soap and water immediately. If toner is spilled inside the printer, wipe it clean.

## Replacing Toner Cartridges and the Waste Toner Collector

When a message is displayed prompting you to replace the toner cartridges and the waste toner collector, select **Next** or **How To** and then view the animations displayed on the printer's control panel to learn how to replace the toner cartridges and the waste toner collector.

### **Note:**

*A waste toner collector is supplied with the toner cartridge.*

## Related Information

- ➔ [“Precautions when Handling Consumables” on page 126](#)
- ➔ [“Handling Precautions when Replacing the Toner Cartridge” on page 127](#)
- ➔ [“Consumable Products Code” on page 179](#)

## Print Quality is Poor

### Printouts are Light, Dark, Faint, or Dirty

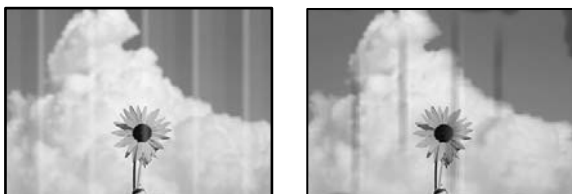

The following causes can be considered.

#### ■ Unsupported paper is being used.

##### Solutions

Use paper supported by this printer.

➔ [“Available Paper and Capacities” on page 176](#)

➔ [“Unavailable Paper Types” on page 178](#)

#### ■ Paper is moist or too dry.

##### Solutions

Replace the paper.

#### ■ The paper settings on the printer are incorrect.

##### Solutions

Make sure the paper size and paper type settings match the actual paper size and paper type loaded in the printer.

➔ [“Paper Size and Type Settings” on page 32](#)

#### ■ The toner save mode is on.

##### Solutions

The toner save feature saves toner while printing, so the print quality is lower than for normal printing. This is useful for printing when you are not concerned about the print quality, such as a test print. Turn off the toner save mode using the printer driver or the printer's control panel menus.

##### Control panel

Select **Settings** > **General Settings** > **Printer Settings** > **PDL Print Configuration** > **Common Settings**, and then set **Toner Save Mode** to **Off**.

##### Windows

Select the printer driver's **More Options** tab, **Image Options**, and then clear **Toner Save**.

##### Mac OS

Select **System Preferences** from the Apple menu > **Printers & Scanners** (or **Print & Scan**, **Print & Fax**), and then select the printer. Click **Options & Supplies** > **Options** (or **Driver**). Select **Off** as the **Toner Save** setting.



### ■ Quality is set to Fast (300 dpi) in the printer driver.

#### Solutions

If you want to print using good quality, set **Quality** to **Fine** (600 dpi). If you want to make line drawings more precise, set **Quality** to **More Settings**, and then move the slider to the **Quality** side. Note that you may not be able to print complicated data if there is insufficient memory. In this case, return **Quality** to **Fast** (300 dpi).

If you want to make line drawings more precise, select the **More Options** tab > **Image Options**, and then disable **Emphasize Thin Lines**.

### ■ The paper path is smeared.

#### Solutions

See the animations displayed on the printer's LCD screen to clean the paper path. Select , and then select **Troubleshooting** > **Poor Print Quality** > **Toner smudges on paper**.

### ■ The printer is being used at high altitude.

#### Solutions

If you are using the printer at a high altitude, select **Settings** > **General Settings** > **System Administration** > **Printer Adjust Menu**, and then change the **Highland** setting.

The printer provides other adjustment features in the **Printer Adjust Menu**. See the related information below for details.

➔ [“Printer Adjust Menu” on page 201](#)

### ■ Non-genuine consumables are used.

#### Solutions

This product is designed to provide the best print quality when using genuine toner. Other products not manufactured by Epson may cause damage or reduce print quality that is not covered by Epson's warranties, and under certain circumstances, may cause erratic printer behavior. Epson recommends the use of genuine Epson toner cartridges. Make sure that the cartridge code matches the product.

### ■ Condensation occurs inside the printer.

#### Solutions

Condensation occurs due to temperature differences in the printer and the surrounding air. If you use a heater in low temperature conditions in winter, the warmed air touches the printer and the water vapor causes condensation. Select **Settings** > **General Settings** > **System Administration** > **Printer Adjust Menu**, and then set **Drum Heater** to **On**, leave the printer turned on, and then if the printer is warm enough, try printing.

### ■ The toner cartridge has deteriorated, is damaged or is nearing the end of its service life.

#### Solutions

If you cannot improve the problem after printing several pages, replace the toner cartridge with a new one.

■ **The printer driver settings need to be changed (Windows).**

**Solutions**

Select the **Maintenance** tab > **Extended Settings**, and then set **Printer Control Language** to **ESC/Page (-Color)**.

Select the **More Options** tab, select **Custom** from the **Tone Correction**, and then select **Advanced**. Select **Enh.MG**, and then move the slider to the **Light** side.

■ **The density setting has been changed in the printer driver (Windows).**

**Solutions**

Select the **More Options** tab > **Extended Settings**, and then adjust the **Density** setting.

■ **The Charging Roller Voltage setting has been changed on the printer.**

**Solutions**

Select **Settings** > **General Settings** > **System Administration** > **Printer Adjust Menu**, and then change the **Charging Roller Voltage** setting.

■ **Drum Refresh with paper needs to be performed.**

**Solutions**

Select **Settings** > **General Settings** > **System Administration** > **Printer Adjust Menu**, and then select **Drum Refresh with paper**.

## The Position, Size, or Margins of the Printout Are Incorrect



The following causes can be considered.

■ **The paper is loaded incorrectly.**

**Solutions**

Load paper in the correct direction, and slide the edge guide against the edge of the paper.

➔ [“Loading Paper” on page 32](#)

■ **The size of the paper is set incorrectly.**

**Solutions**

Select the appropriate paper size setting.

**The margin setting in the application software is not within the print area.**

**Solutions**

Adjust the margin setting in the application so that it falls within the printable area.

➔ [“Printing Features” on page 195](#)

**The print start position settings on the printer have been changed.**

**Solutions**

You need to set the print start position (offset) for some applications. See the following to make settings.

➔ [“Printer Adjust Menu” on page 201](#)

**Printed Characters Are Incorrect or Garbled**

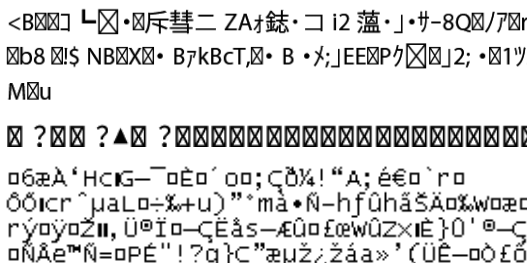

The following causes can be considered.

**There is a problem with the usage environment.**

**Solutions**

If you can perform test printing or status printing correctly, there may be a problem in the usage environment. Check the following points.

- The printer is connected correctly with the correct cable.
- The computers specifications support the printer's system requirements.

**You are using the printer driver for a different printer.**

**Solutions**

Make sure that the printer driver you are using is for this printer. Check the printer name on the top of the printer driver window.

**Cannot Read Barcodes**



01234

### The printer driver settings do not match the barcodes. (Windows)

#### Solutions

- ❑ For the **Quality** setting, select **Fine** (600 dpi) or select **More Settings**, and then move the slider to the **Quality** side.
- ❑ Select the **Maintenance** tab, **Extended Settings**, and then select **Barcode mode**.
- ❑ Select the **More Options** tab > **Image Options**, and then disable **Emphasize Thin Lines**.

### Cannot Print Collated Pages

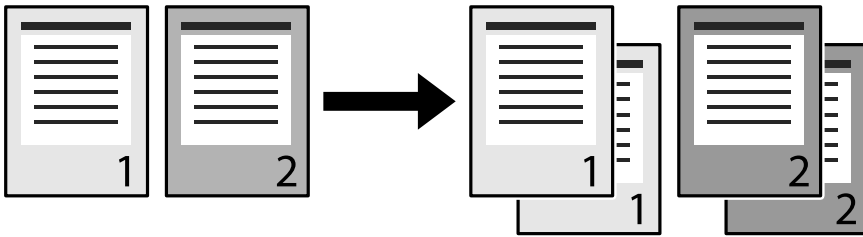

### The collated setting is selected in the printer driver and application (Windows).

#### Solutions

If you make collated settings in the printer driver and the application from which you are printing, you may not be able to perform collated printing correctly. When you have made collated settings in the application, do not make settings in the printer driver.

### Last Page is Printed on Opposite Side in 2-sided Printing

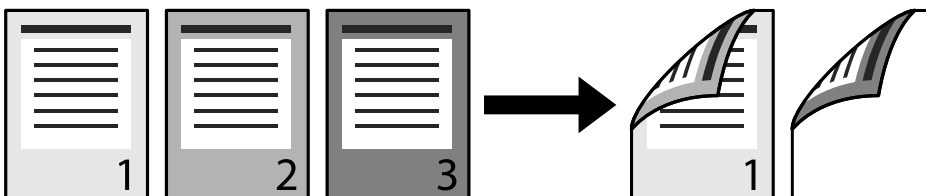

### The One-side 2-sides conversion setting is wrong.

#### Solutions

Select **Settings** > **General Settings** > **Printer Settings** > **PDL Print Configuration** > **Common Settings**, and then set **Convert to Simplex** to **Off**.

### The Font Cannot be Printed.

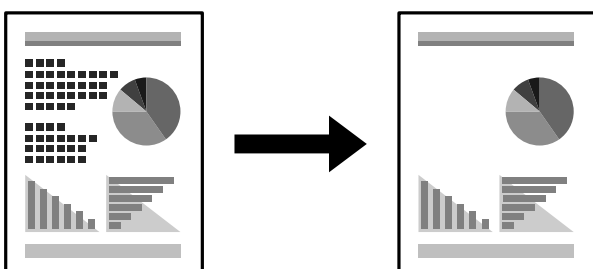

The following causes can be considered.

### ■ For Windows users, you may use the printer fonts substituted for specified TrueType fonts.

#### Solutions

In the printer driver's **Maintenance** tab, select **Extended Settings**, and then clear **Print TrueType fonts with substitution**.

### ■ The selected font is not supported by your printer.

#### Solutions

Select a font that is supported by the printer in the application, and then print.

## Printer Does Not Print Correctly While Using PostScript Printer Driver

The following causes can be considered.

### ■ There is a problem with the data.

#### Solutions

- If the file is created in an application that allows you to change the data format, such as Adobe Photoshop, make sure that the settings in the application match the settings in the printer driver.
- EPS files made in binary format may not be printed correctly. Set the format to ASCII when making EPS files in an application.
- For Windows, the printer cannot print binary data when it is connected to the computer using a USB interface. Set the **Output Protocol** setting on the **Device Settings** tab in the printer properties to **ASCII** or **TBCP**.
- For Windows, select the appropriate substitution fonts on the **Device Settings** tab in the printer properties.

---

## Cannot Solve Problem

If you cannot solve the problem after trying all of the solutions, contact Epson support.

---

# **Adding or Replacing the Computer or Devices**

Connecting to a Printer that has been Connected to the Network. . . . .	135
Re-setting the Network Connection. . . . .	136
Checking the Network Connection Status. . . . .	137

## Connecting to a Printer that has been Connected to the Network

When the printer has already been connected to the network, you can connect a computer or a smart device to the printer over the network.

### Using a Network Printer from a Second Computer

We recommend using the installer to connect the printer to a computer. You can run the installer using one of the following methods.

- ❑ Setting up from the website

Access the following website, and then enter the product name. Go to **Setup**, and then start setting up.

<http://epson.sn>

- ❑ Setting up using the software disc (only for the models that come with a software disc and users with Windows computers with disc drives.)

Insert the software disc into the computer, and then follow the on-screen instructions.

### Selecting the Printer

Follow the on-screen instructions until the following screen is displayed, select the printer name you want to connect to, and then click **Next**.

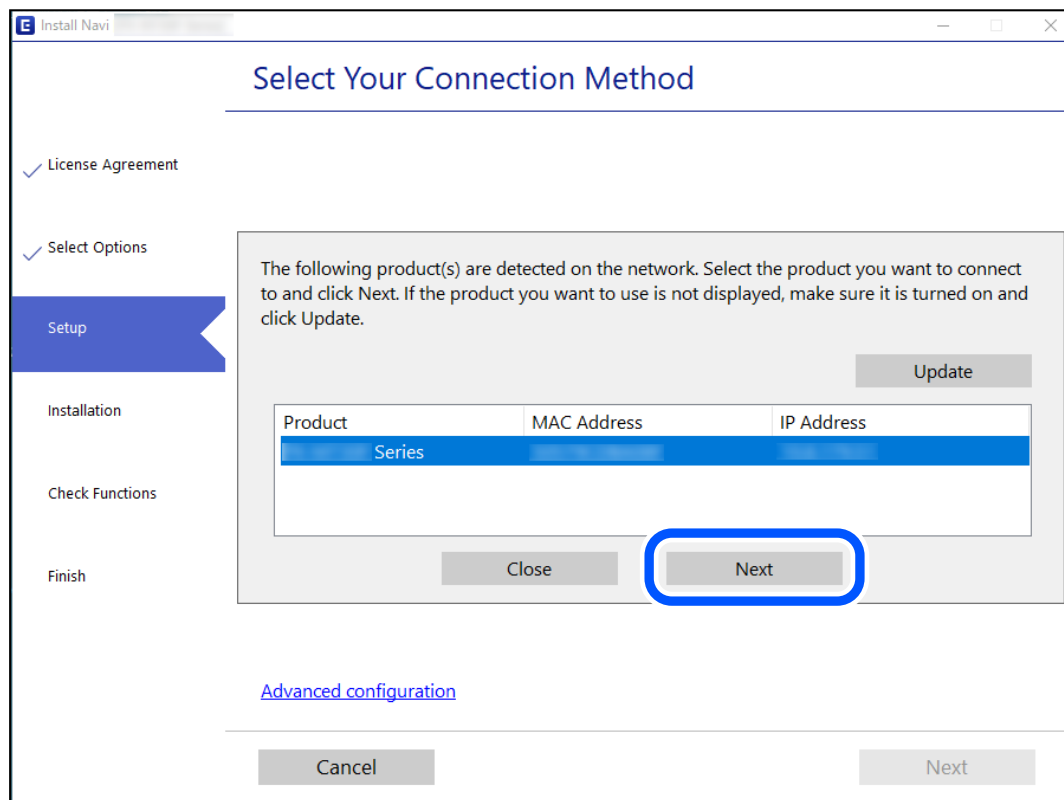

Follow the on-screen instructions.

## Using a Network Printer from a Smart Device

When the wireless router is connected to the same network as the printer, you can operate the printer via the wireless router from your smart device.

See the following for more details.

[“Making Settings for Connecting to the Smart Device” on page 136](#)

---

## Re-setting the Network Connection

This section explains how to make the network connection settings and change the connection method when replacing the wireless router or the computer.

### When Replacing the Wireless Router

When the wireless router is connected to the same network as the printer, you can operate the printer via the wireless router from your computer or the smart device.

When you replace the wireless router, make settings for the connection between the computer or the smart device and the printer.

You need to make these settings if you change your Internet service provider and so on.

### Making Settings for Connecting to the Computer

We recommend using the installer to connect the printer to a computer. You can run the installer using one of the following methods.

- Setting up from the website

Access the following website, and then enter the product name. Go to **Setup**, and then start setting up.

<http://epson.sn>

- Setting up using the software disc (only for the models that come with a software disc and users with Windows computers with disc drives.)

Insert the software disc into the computer, and then follow the on-screen instructions.

### Making Settings for Connecting to the Smart Device

You can operate the printer via the wireless router from your smart device when you connect the printer to the same network as the wireless router. To use the printer from a smart device, set up from the following website. Access to the website from the smart device that you want to connect to the printer.

<http://epson.sn> > **Setup**

### When Changing the Computer

When changing the computer, make connection settings between the computer and the printer.



## Making Settings for Connecting to the Computer

We recommend using the installer to connect the printer to a computer. You can run the installer using one of the following methods.

- Setting up from the website

Access the following website, and then enter the product name. Go to **Setup**, and then start setting up.

<http://epson.sn>

- Setting up using the software disc (only for the models that come with a software disc and users with Windows computers with disc drives.)

Insert the software disc into the computer, and then follow the on-screen instructions.

Follow the on-screen instructions.

## Changing the Connection Method to the Computer

This section explains how to change the connection method when the computer and the printer have been connected.

### Changing from USB to a Network Connection

Using the installer and re-set up in a different connection method.

- Setting up from the website

Access the following website, and then enter the product name. Go to **Setup**, and then start setting up.

<http://epson.sn>

- Setting up using the software disc (only for the models that come with a software disc and users with Windows computers with disc drives.)

Insert the software disc into the computer, and then follow the on-screen instructions.

### Selecting Change the Connection Methods

Follow the on-screen instructions until the following screen is displayed.

Select the network connection that you want to use, **Connect via wireless network (Wi-Fi)** or **Connect via wired LAN (Ethernet)**, and then click **Next**.

**Note:**

*The displayed connection method differs depending on the model.*

Follow the on-screen instructions.

---

## Checking the Network Connection Status

You can check the network connection status in the following way.

### Related Information

- ➔ [“Checking the Network Connection Status from the Control Panel” on page 138](#)
- ➔ [“Printing a Network Connection Report” on page 138](#)

## Checking the Network Connection Status from the Control Panel

You can check the network connection status using the network icon or the network information on the printer's control panel.

### Checking the Network Connection Status using the Network Icon

You can check the network connection status using the network icon on the printer's home screen.

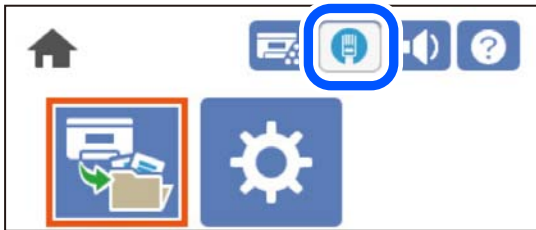

#### Related Information

➔ [“Guide to the Network Icon” on page 27](#)

## Displaying Detailed Network Information on the Control Panel

When your printer is connected to the network, you can also view other network-related information by selecting the network menus you want to check.

1. Select **Settings** on the home screen.
2. Select **General Settings** > **Network Settings** > **Network Status**.
3. To check the information, select the menus that you want to check.
  - Wired LAN Status**  
Displays the network information for Ethernet.
  - Print Status Sheet**  
Prints a network status sheet. The information for Ethernet is printed on two or more pages.

## Printing a Network Connection Report

You can print a network connection report to check the network status for the printer.

1. Select **Settings** on the home screen.  
To select an item, use the ▲ ▼ ◀▶ buttons, and then press the OK button.
2. Select **General Settings** > **Network Settings** > **Connection Check**.  
The connection check starts.

3. Select **Print Check Report**.

4. Print the network connection report.

If an error has occurred, check the network connection report, and then follow the printed solutions.

### Related Information

➔ [“Messages and Solutions on the Network Connection Report” on page 139](#)

## Messages and Solutions on the Network Connection Report

Check the messages and error codes on the network connection report, and then follow the solutions.

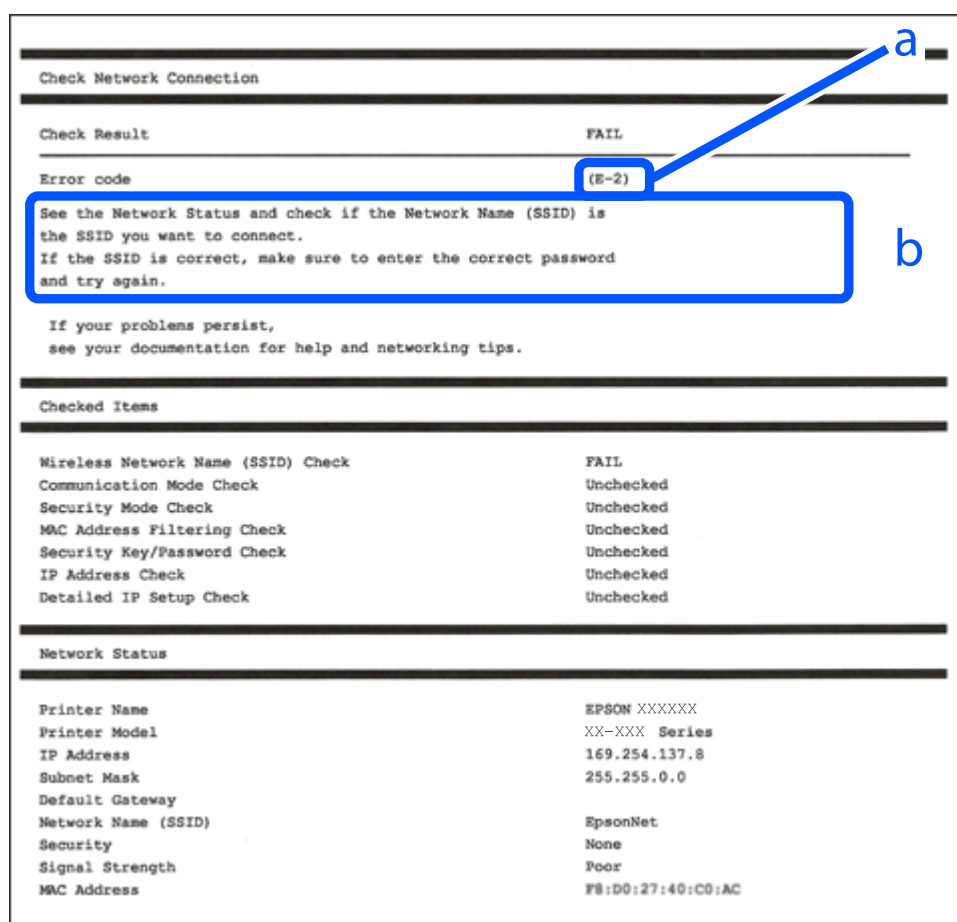

a. Error code

b. Messages on the Network Environment

### Related Information

➔ [“E-1” on page 140](#)

➔ [“E-8” on page 140](#)

➔ [“E-9” on page 140](#)

➔ [“E-10” on page 140](#)

- ➔ [“E-11” on page 141](#)
- ➔ [“E-12” on page 141](#)
- ➔ [“E-13” on page 142](#)

## **E-1**

### **Solutions:**

- Make sure the Ethernet cable is securely connected to your printer and to your hub or other network device.
- Make sure your hub or other network device is turned on.

## **E-8**

### **Solutions:**

- Enable DHCP on the router if the printer's Obtain IP Address setting is set to Auto.
- If the printer's Obtain IP Address setting is set to Manual, the IP address you manually set is invalid due to out of range (for example: 0.0.0.0). Set a valid IP address from the printer's control panel.

### **Related Information**

- ➔ [“Network Settings” on page 191](#)

## **E-9**

### **Solutions:**

Check the following.

- Devices are turned on.
- You can access the Internet and other computers or network devices on the same network from the devices you want to connect to the printer.

If still does not connect your printer and network devices after confirming the above, turn off the router. Wait for about 10 seconds, and then turn it on. Then reset your network settings by downloading and running the installer from the following website.

<http://epson.sn> > **Setup**

### **Related Information**

- ➔ [“Making Settings for Connecting to the Computer” on page 137](#)

## **E-10**

### **Solutions:**

Check the following.

- Other devices on the network are turned on.
- Network addresses (IP address, subnet mask, and default gateway) are correct if you have set the printer's Obtain IP Address to Manual.

Reset the network address if they are incorrect. You can check the IP address, subnet mask, and default gateway from the **Network Status** part on the network connection report.

#### **Related Information**

➔ [“Network Settings” on page 191](#)

## **E-11**

#### **Solutions:**

Check the following.

- The default gateway address is correct if you set the printer's TCP/IP Setup setting to Manual.
- The device that is set as the default gateway is turned on.

Set the correct default gateway address. You can check the default gateway address from the **Network Status** part on the network connection report.

#### **Related Information**

➔ [“Network Settings” on page 191](#)

## **E-12**

#### **Solutions:**

Check the following.

- Other devices on the network are turned on.
- The network addresses (IP address, subnet mask, and default gateway) are correct if you are entering them manually.
- The network addresses for other devices (subnet mask and default gateway) are the same.
- The IP address does not conflict with other devices.

If still does not connect your printer and network devices after confirming the above, try the following.

- Turn off the router. Wait for about 10 seconds, and then turn it on.
- Make network settings again using the installer. You can run it from the following website.

<http://epson.sn> > **Setup**

#### **Related Information**

➔ [“Network Settings” on page 191](#)

➔ [“Making Settings for Connecting to the Computer” on page 137](#)

## E-13

### Solutions:

Check the following.

- Network devices such as a wireless router, hub, and router are turned on.
- The TCP/IP Setup for network devices has not been set up manually. (If the printer's TCP/IP Setup is set automatically while the TCP/IP Setup for other network devices is performed manually, the printer's network may differ from the network for other devices.)

If it still does not work after checking the above, try the following.

- Turn off the router. Wait for about 10 seconds, and then turn it on.
- Make network settings on the computer that is on the same network as the printer using the installer. You can run it from the following website.

<http://epson.sn> > Setup

### Related Information

- ➔ “Network Settings” on page 191
- ➔ “Making Settings for Connecting to the Computer” on page 137

## Printing a Network Status Sheet

You can check the detailed network information by printing it.

1. Select **Settings** on the home screen.  
To select an item, use the ▲ ▼ ◀ ▶ buttons, and then press the OK button.
2. Select **Printer Status/Print >Network** .
3. Select **Print Status Sheet**.
4. Check the message, and then print the network status sheet.

## Checking the Network of the Computer (Windows only)

By using the command prompt, check the connection status of the computer and the connection path to the printer. This will lead you to solve the problems.

ipconfig command

Display the connection status of the network interface that is currently used by the computer.

By comparing the setting information with actual communication, you can check whether the connection is correct. In case there are multiple DHCP servers on the same network, you can find out the actual address assigned to the computer, the referred DNS server, etc.

Format : ipconfig /all

Examples :

```

Administrator: Command Prompt
c:\>ipconfig /all
Windows IP Configuration

Host Name . . . . . : WIN2012R2
Primary Dns Suffix . . . . . : pubs.net
Node Type . . . . . : Hybrid
IP Routing Enabled. . . . . : No
WINS Proxy Enabled. . . . . : No
DNS Suffix Search List. . . . . : pubs.net

Ethernet adapter Ethernet:

Connection-specific DNS Suffix . . : 
Description . . . . . : Gigabit Network Connection
Physical Address. . . . . : XX-XX-XX-XX-XX-XX
DHCP Enabled. . . . . : No
Autoconfiguration Enabled . . . . : Yes
Link-local IPv6 Address . . . . . : fe80::38fb:7546:18a8:d20e%14(Preferred)
IPv4 Address. . . . . : 192.168.111.10(Preferred)
Subnet Mask . . . . . : 255.255.255.0
Default Gateway . . . . . : 192.168.111.1
DHCPv6 IAID . . . . . : 283142549
DHCPv6 Client DUID. . . . . : 00-01-00-01-20-40-2F-45-00-1D-73-6A-44-08
DNS Servers . . . . . : 192.168.111.2
NetBIOS over Tcpip. . . . . : Enabled

Tunnel adapter isatap.{00000000-ABCD-EFGH-IJK-LMNOPQRSTUUV}>:

Media State . . . . . : Media disconnected
Connection-specific DNS Suffix . . : 
Description . . . . . : Microsoft ISATAP Adapter #2
Physical Address. . . . . : 00-00-00-00-00-00-E0
DHCP Enabled. . . . . : No
Autoconfiguration Enabled . . . . : Yes

c:\>_
    
```

pathping command

You can confirm the list of routers passing through the destination host and the routing of communication.

Format : pathping xxx.xxx.xxx.xxx

Examples : pathping 192.0.2.222

```

Administrator: Command Prompt
c:\>pathping 192.168.111.20
Tracing route to EPSONAB12AB [192.168.111.20]
over a maximum of 30 hops:
 0  WIN2012R2.pubs.net [192.168.111.10]
 1  EPSONAB12AB [192.168.111.20]

Computing statistics for 25 seconds..
Hop  RTT      Source to Here   This Node/Link   Address
 0      0/ 100 = 0%      0/ 100 = 0%      WIN2012R2.pubs.net [192.168.111.10]
 1  38ms     0/ 100 = 0%      0/ 100 = 0%      EPSONAB12AB [192.168.111.20]

Trace complete.

c:\>_
    
```

---

# Using Optional Items

List of Optional Items. . . . .	145
Precautions when Installing Optional Items. . . . .	147
Checking the Installed Optional Items. . . . .	147
Printer Stand. . . . .	148
Paper Cassette Unit. . . . .	152
Face-up Tray. . . . .	157
HDD (AL-M8250DN/AL-M8150DN Only). . . . .	158
Ethernet Board (10/100/1000 Base-T, Ethernet) (AL-M8250DN/AL-M8150DN Only). . . . .	166



## List of Optional Items

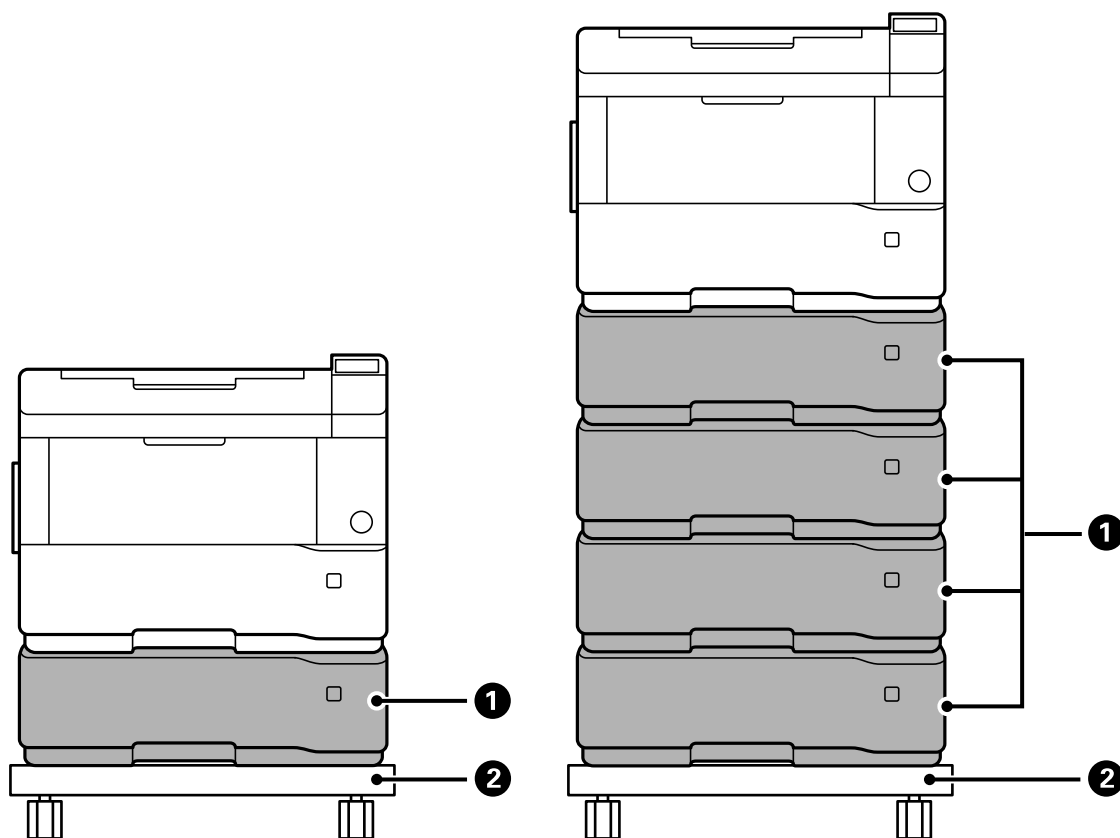

No.	Optional Item	Code	Overview
①	500-Sheet Paper Cassette Unit	C12C802811	<p>Allows you to load up to 500 sheets of plain paper (80 g/m<sup>2</sup>).</p> <p>You can install up to 4 paper cassette units for the AL-M8250DN/AL-M8150DN, and 3 paper cassette units for the AL-M7150DN .</p> <p><a href="#">"Paper Cassette Unit" on page 152</a></p>
②	Printer Stand	C12C932091	<p>With casters.</p> <p><a href="#">"Printer Stand" on page 148</a></p>

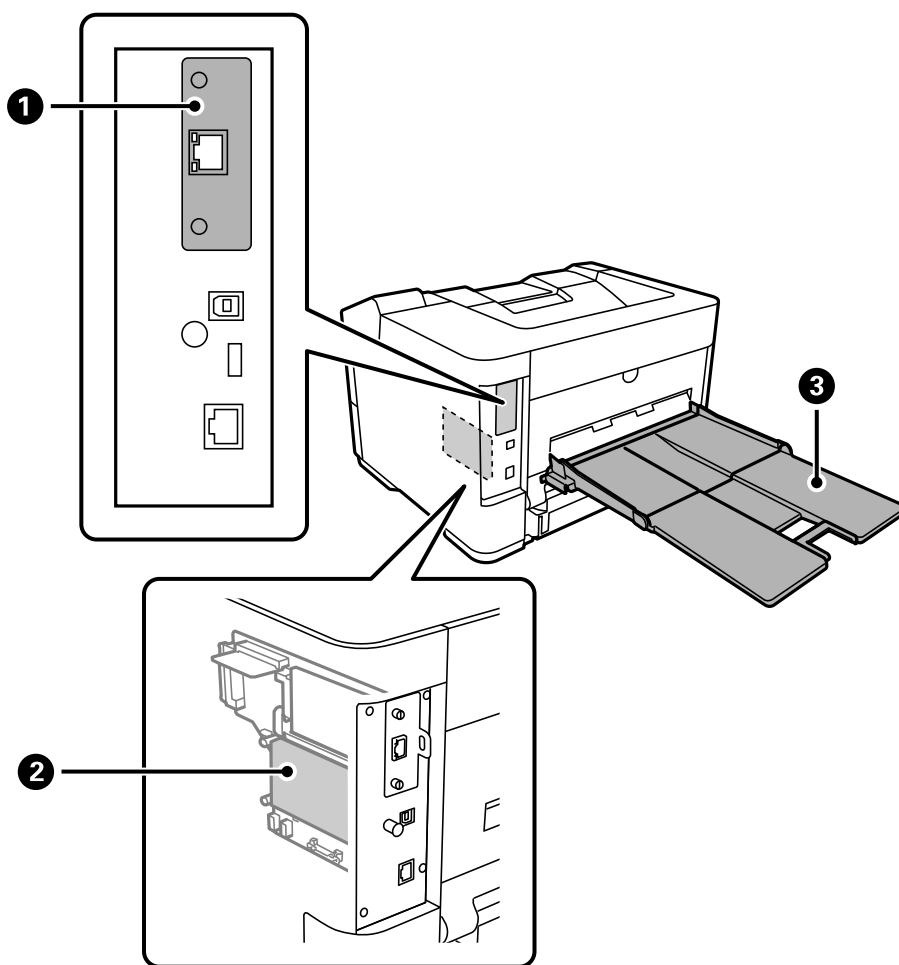

No.	Optional Item	Code	Overview
1	10/100/1000 Base-T, Ethernet	C12C935771	<p>Two wired LAN networks are available. The communication speed is a high-speed interface that supports 1 Gbit/s.</p> <p>Only available for the AL-M8250DN/AL-M8150DN.</p> <p><a href="#">"Ethernet Board (10/100/1000 Base-T, Ethernet) (AL-M8250DN/AL-M8150DN Only)" on page 166</a></p>
2	HDD	C12C934441	<p>You can install an HDD. Use the designated HDD (model number: C12C934441). Operation cannot be guaranteed if other HDDs are connected.</p> <p>Only available for the AL-M8250DN/AL-M8150DN .</p> <p><a href="#">"HDD (AL-M8250DN/AL-M8150DN Only)" on page 158</a></p>
3	Face-Up Tray	C12C817071	<p>Hold up to 250 sheets of plain paper (80 g/m<sup>2</sup>).</p> <p><a href="#">"Face-up Tray" on page 157</a></p>

## Precautions when Installing Optional Items

Prepare a coin or a screwdriver in advance.

Make sure that there is no damage to the optional items and that nothing is missing. If you notice any damage or missing items, contact the dealer where you purchased your product.

 **Warning:**

*Do not attempt to take apart this product yourself except as specifically instructed in the printer's documentation. Otherwise, safety devices could be damaged and accidents such as laser light leakage, abnormal heating of the the fuser unit or electric shock in high voltage sections may occur.*

 **Caution:**

- When carrying the printer, lift it using a stable position. Lifting the printer using an unstable position may result in injury.
- Because this printer is heavy, it should always be carried by two or more people when unpacking and transporting.
- When you inserting cables and optional items, make sure you insert them in the correct direction and by following the correct steps according to the manual. Otherwise, there is a risk of fire or injury.

 **Important:**

*Turn off the printer by pressing the  button and then unplug the power cord. Do not unplug the power code before the printer turns off. Otherwise, the printer may be damaged.*

## Checking the Installed Optional Items

You can use the Configuration Status Sheet to check if optional items are installed correctly.

1. Select Settings on the printer's control panel.

Press     button to select menus and then press the OK button.



2. Select **Printer Status/Print > Print Status Sheet > Configuration Status Sheet.**

3. Select **Print.**

If you want to print on both sides, select **2-Sided Printing.**

## Printer Stand

### Installing the Printer Stand to the Paper Cassette Unit

You can install the printer stand on the paper cassette unit or the printer directly.

The instructions below describe installing on the paper cassette unit as an example. We recommend using the printer stand if you install the paper cassette units.

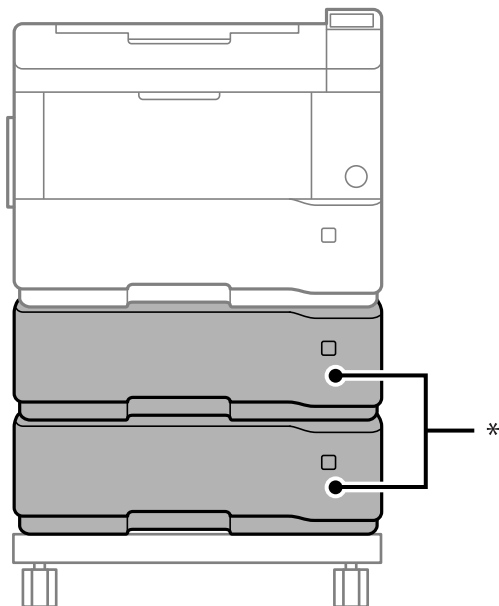

\*: You can install up to 4 paper cassette units for the AL-M8250DN/AL-M8150DN, and 3 paper cassette units for the AL-M7150DN .

1. Place the printer stand on a flat surface and lock the front casters.  
Keep the casters locked to prevent the printer from moving.

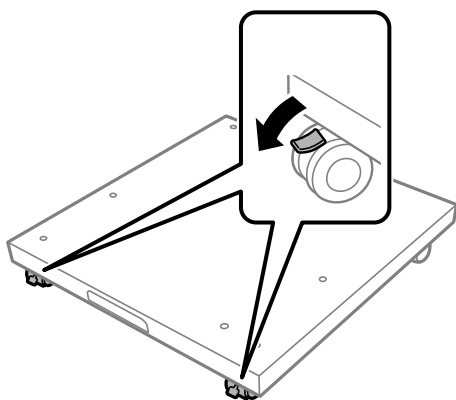

2. Install two guide pins on the printer stand.

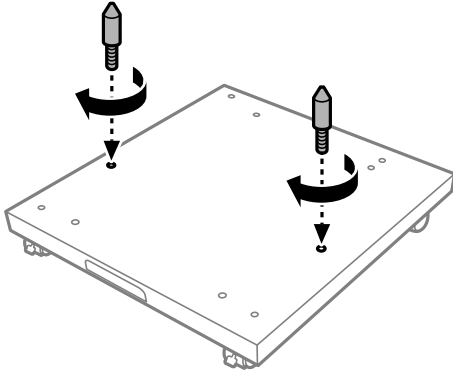

3. Pull out the upper paper cassette.

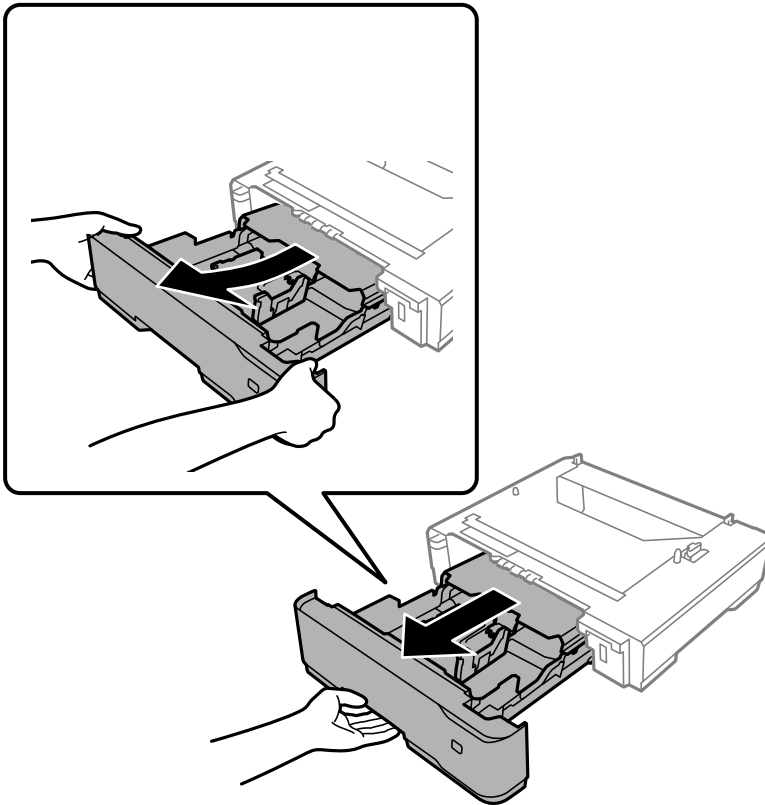

4. Set the lowest paper cassette unit on the printer stand. Align each of the holes on the bottom with the guide pins.

Install the printer after you have installed all of the paper cassette units on the printer stand.

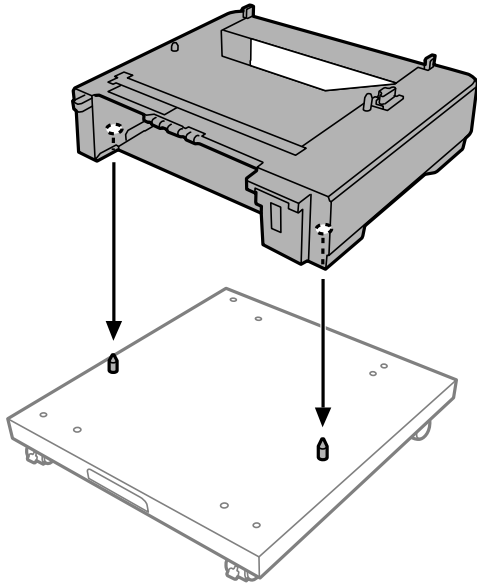

5. Reinsert the paper cassette into the paper cassette unit.

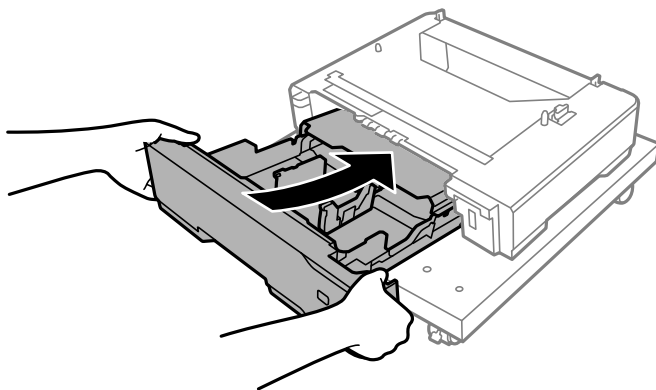

6. Use screws to secure the two metal hooks to the back of the printer as shown below.

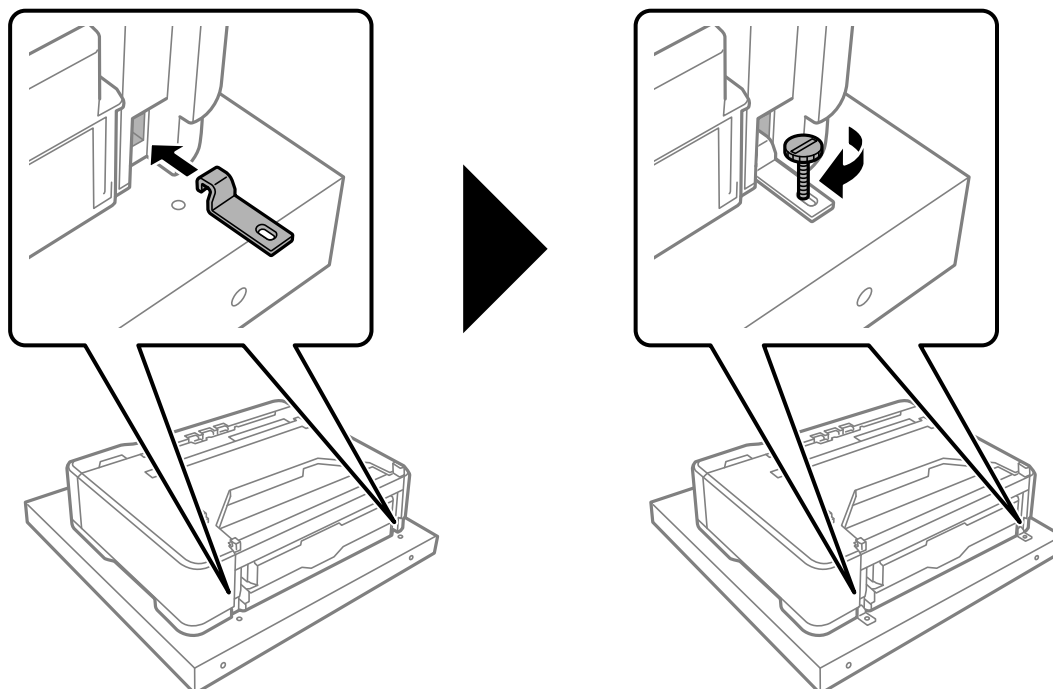

See the Related Information when installing the printer on the paper cassette unit or the printer stand.

**Related Information**

➔ [“Installing the Paper Cassette Units to the Printer” on page 152](#)

## Moving the Printer While the Printer Stand is Attached

Unlock the stopper for the casters. Avoid steps when moving the printer to prevent it from being subjected to shocks.

**Related Information**

➔ [“Moving and Transporting the Printer” on page 104](#)

## Printer Stand Specifications

Dimensions*	<ul style="list-style-type: none"> <li>❑ Width: 512 mm (20.2 in.)</li> <li>❑ Depth: 518 mm (20.4 in.)</li> <li>❑ Height: 109 mm (4.3 in.)</li> </ul>
Weight	Approx. 5.1 kg (11.3 lb)

\*:Including the 20 mm protruding pin.

## Paper Cassette Unit

### Installing the Paper Cassette Units to the Printer

 **Caution:**

- ❑ *Make sure you turn off the printer, unplug the power cord from the printer, and disconnect any cables before starting installation. Otherwise, the power cord may be damaged resulting in fire or electric shock.*
- ❑ *When lifting the printer, place your hands in the positions shown below. If you lift the printer holding other positions, the printer may fall or you may trap your fingers when placing the printer.*

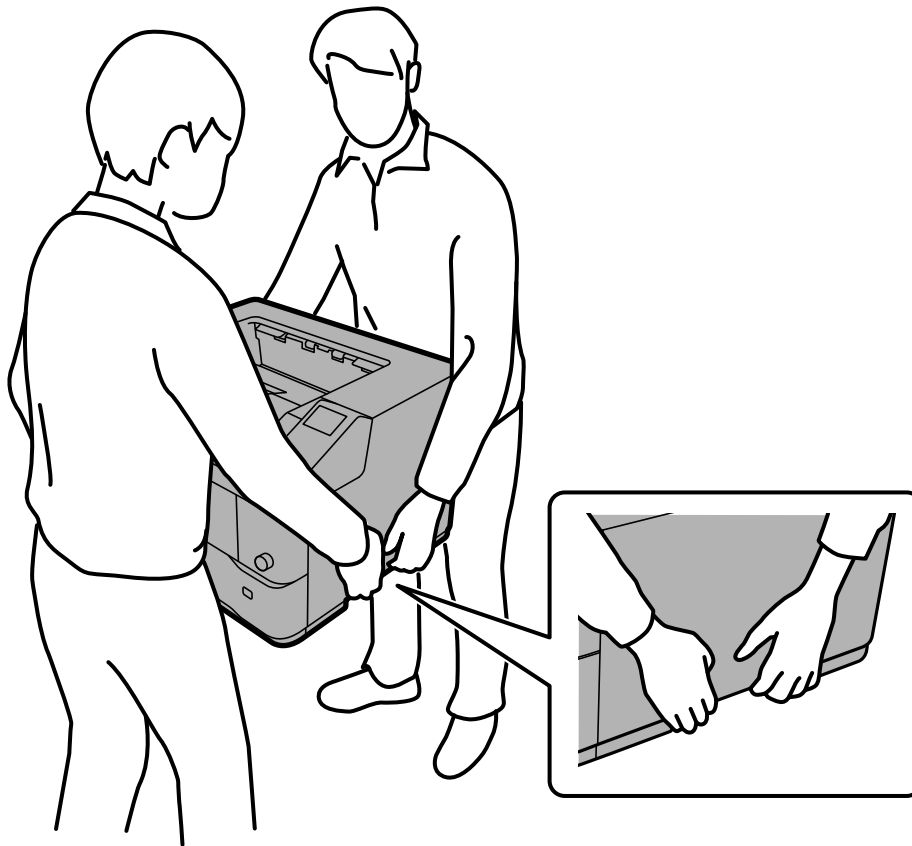

- ❑ *Do not touch the projections on the bottom of the printer that are for connecting an optional paper cassette.*

 **Important:**

*If you are using the printer stand, install it onto the lowest paper cassette unit in advance.*

*When installing the printer stand, make sure you lock the casters. Otherwise, the printer may move and cause an accident.*



1. Unlock the fixture on the back as shown below.

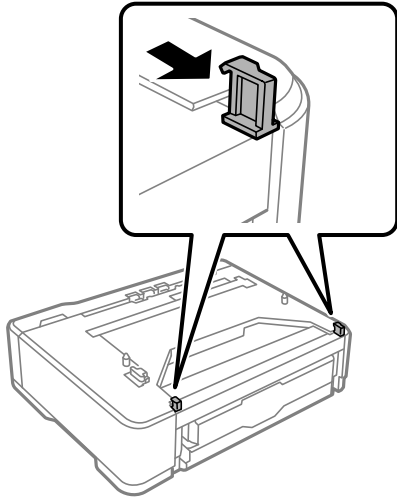

2. Place the paper cassette unit or the printer on the lower paper cassette unit.

Align each of the holes with the guide pins of the paper cassette unit, and then lower the paper cassette unit or the printer until it resets securely on the unit.

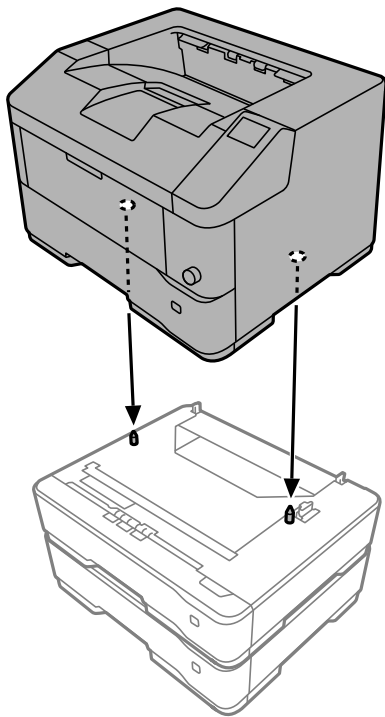
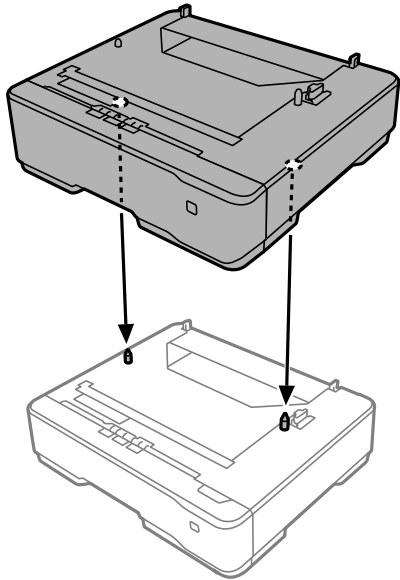

- Lock the fixtures to secure the paper cassette units.

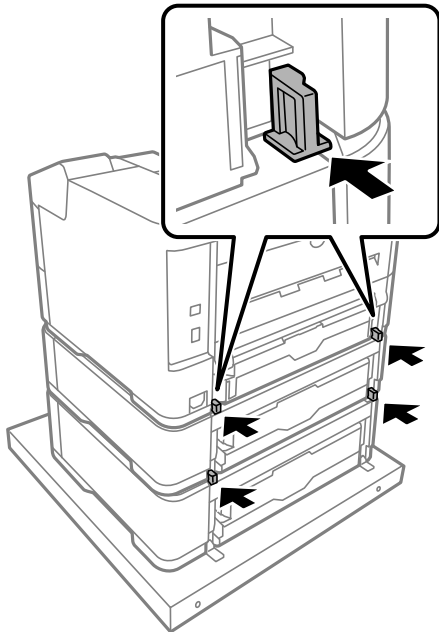

- Reconnect the USB cable and power cord, and then turn on the printer.
- After installing the paper cassette units, print a Configuration Status Sheet to check if the optional items are installed correctly.

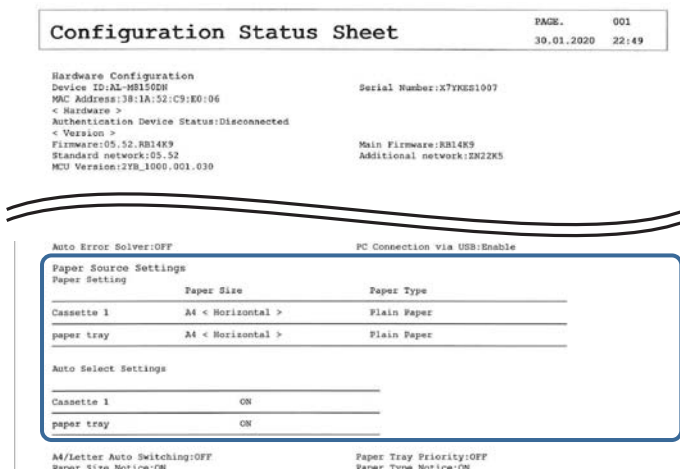

### Related Information

- ➔ [“Installing the Printer Stand to the Paper Cassette Unit” on page 148](#)
- ➔ [“Checking the Installed Optional Items” on page 147](#)

## Setting the Paper Cassette Unit in the Printer Driver

To use the installed paper cassette unit, the printer driver needs to acquire the necessary information.

## Setting the Paper Cassette Unit in the Printer Driver - Windows

**Note:**

Log on to your computer as an administrator.

1. Open the printer list on the computer.
  - Windows 10/Windows Server 2016  
Click on the start button, and then select **Windows System > Control Panel > View devices and printers** in **Hardware and Sound**.
  - Windows 8.1/Windows 8/Windows Server 2012 R2/Windows Server 2012  
Select **Desktop > Settings > Control Panel > View devices and printers** in **Hardware and Sound**.
  - Windows 7/Windows Server 2008 R2  
Click the start button, and select **Control Panel > View devices and printers** in **Hardware and Sound**.
  - Windows Vista/Windows Server 2008  
Click the start button, and then select **Control Panel > Printers** in **Hardware and Sound**.
  - Windows XP/Windows Server 2003 R2/Windows Server 2003  
Click the start button, and select **Control Panel > Printers and Other Hardware > Printers and Faxes**.
2. Right-click on your printer, or press and hold it, select **Printer properties** or **Property**, and then click the **Optional Settings** tab.
3. Select **Acquire from Printer**, and then click **Get**.  
**Optional Paper Sources** information is displayed in **Current Printer Information**.
4. Click **OK**.

## Setting the Paper Cassette Unit in the Printer Driver - Mac OS

1. Select **System Preferences** from the Apple menu > **Printers & Scanners** (or **Print & Scan, Print & Fax**), and then select the printer. Click **Options & Supplies > Options** (or **Driver**).
2. Set **Lower Cassette** according to the number of paper cassettes.
3. Click **OK**.

## Problems with the Paper Cassette Unit

### Paper Does Not Feed from the Paper Cassette Units

If you have added paper cassette units, you need to make settings in the printer driver.

## Paper Cassette Unit Specifications

Supported Paper	Type	Plain paper, Recycled paper, High quality plain paper
	Size	A3, B4, A4, A5 (Portrait), B5, Letter, Half Letter (Portrait), Legal, Government Letter, Government Legal, Executive, F4, 11×17 in
	Weight of Paper	60 to 120g/m <sup>2</sup>
Capacity	Maximum 500 Sheets (80 g/m <sup>2</sup> )	
Dimensions*	<input type="checkbox"/> Width: 490 mm (19.3 in.) <input type="checkbox"/> Depth: 410 mm (16.2 in.) <input type="checkbox"/> Height: 121 mm (4.8in.)	
Weight	Approx. 5 kg (11.1 lb)	

\* : Without the protruding pins.

## Face-up Tray

### Installing the Face up Tray

Install the face up tray on the back of the printer.

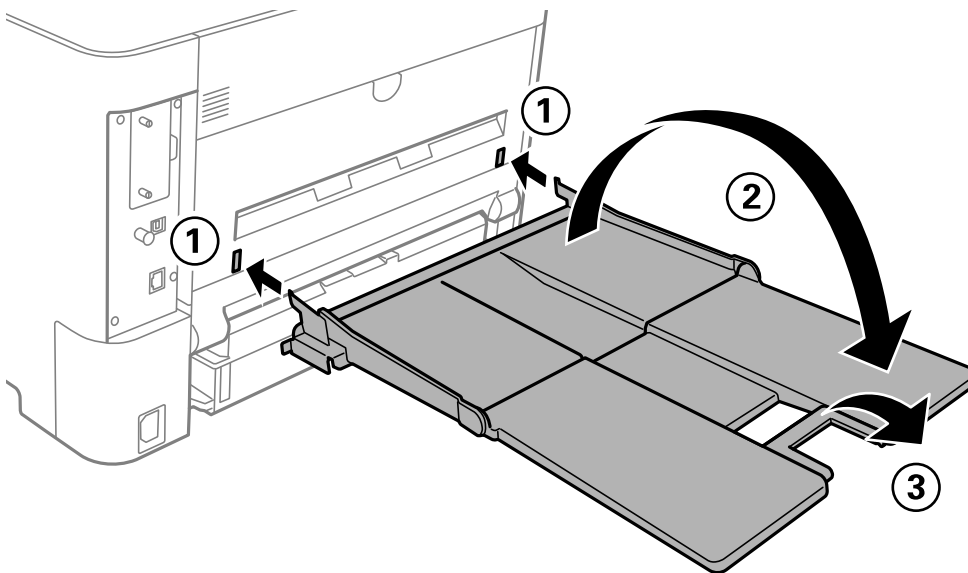

**Note:**

- Holds up to 250 sheets (plain paper 80 g/m<sup>2</sup>).
- Make sure you open the face up tray when you use the printer.
- If you use both the printer stand and the face up tray, you can install up to 3 paper cassette units.

## Output to the Face up Tray Using Setting from the Printer Driver

Select the face up tray in the printer driver as shown below. The printer driver settings override settings made using the control panel.

Windows: **Main > Paper Output Settings > Output Tray > Face-up**

Mac OS: **Print Settings > Output Tray > Face Up Tray**

## Face up Tray Specifications

Dimensions	<ul style="list-style-type: none"> <li><input type="checkbox"/> Width: 365 mm (14.4 in.)</li> <li><input type="checkbox"/> Depth: 464 mm (18.3 in.)</li> <li><input type="checkbox"/> Height: 69 mm (2.7 in.)</li> </ul>
Weight	Approx. 1 kg (2.2 lb)

## HDD (AL-M8250DN/AL-M8150DN Only)

### Installing the HDD

Prepare a screwdriver when you install the HDD.



**Caution:**

*Make sure you turn off the power, unplug the power cord, and check that all wiring has been disconnected. The cord may be damaged, resulting in electric shock or fire.*



**Important:**

- Install the designated HDD (model number: C12C934441). Operation cannot be guaranteed if other HDDs are installed.
- Electrostatic discharge can damage printer parts. Make sure you discharge static electricity from your body by touching grounding yourself before installing the HDD.
- Handle the HDD with care. Excessive force may damage the components.

1. Turn off the printer by pressing the  button.
2. Disconnect all cables such as the power cord and USB cable.

3. Loosen the four screws of the additional interface slot on the back of the printer.

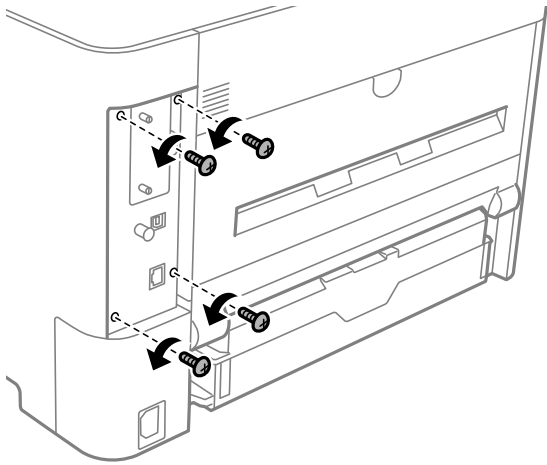

4. Pull out the additional interface slot. Pull the black parts of the slot straight out and avoid tilting.

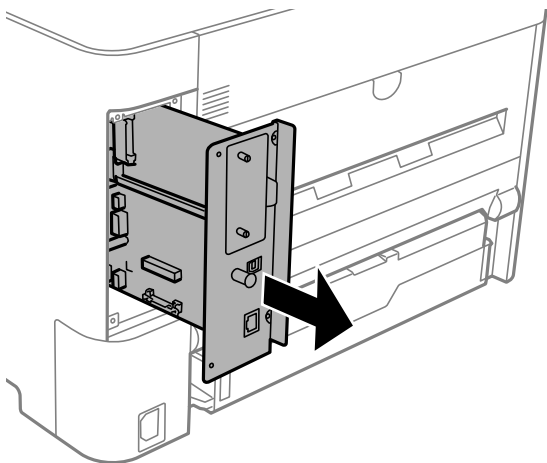

5. See the following to identify where to place the HDD.

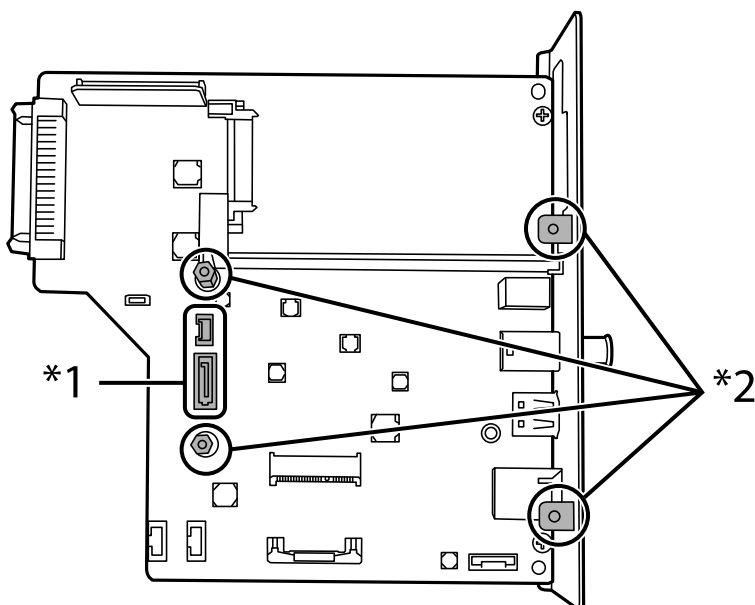

\*1: Cable outlet

\*2: Screw positions

6. Confirm the bundled items.

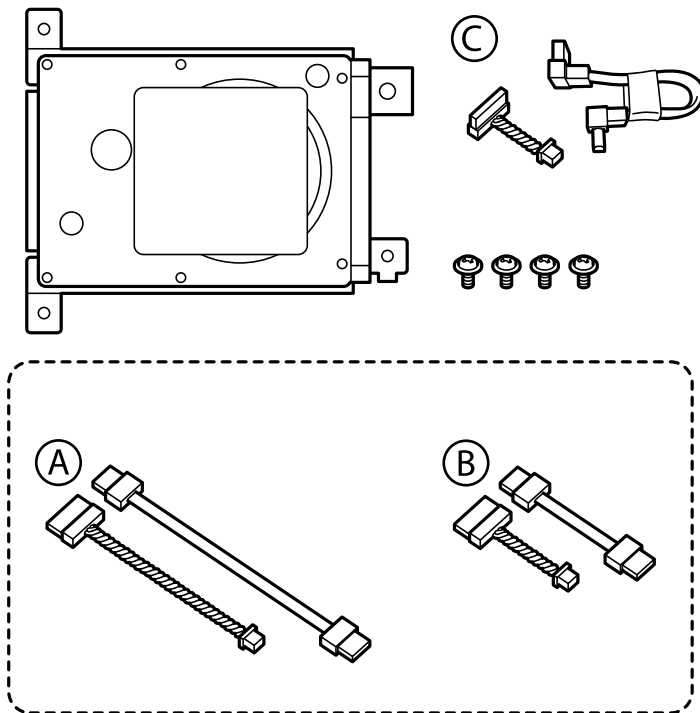

**Note:**

Cable sets A and B are not used.

7. Connect the two cables to the HDD.

Make sure you connect the cables in the correct direction as shown below.

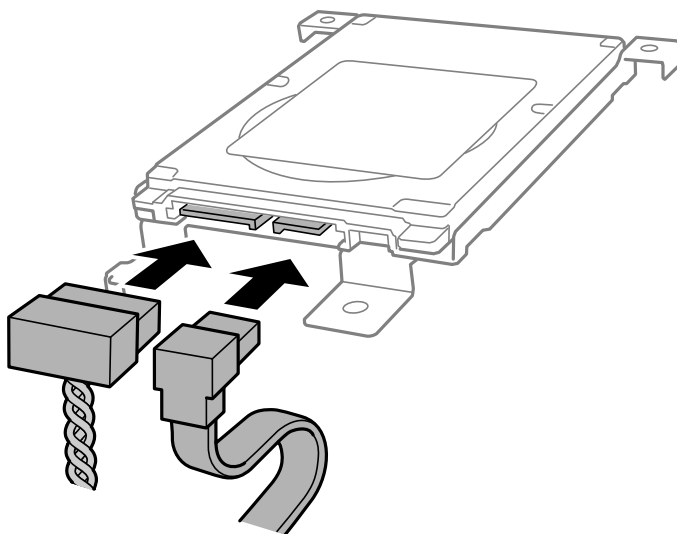



8. Connect the two cables to the circuit board.

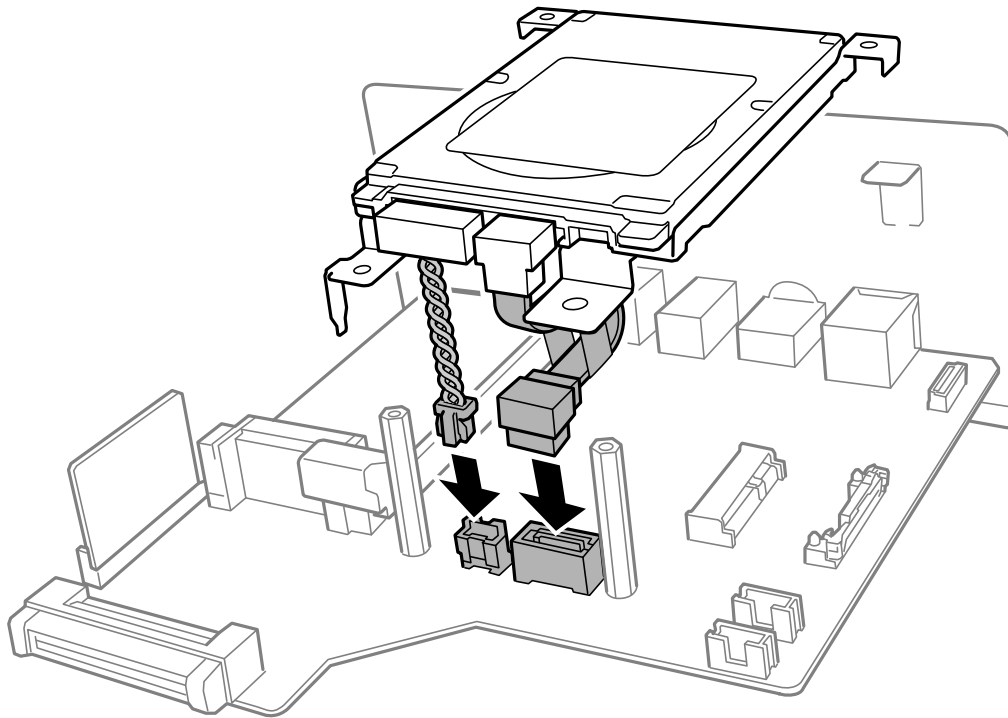

Place the cable under the HDD as shown below.

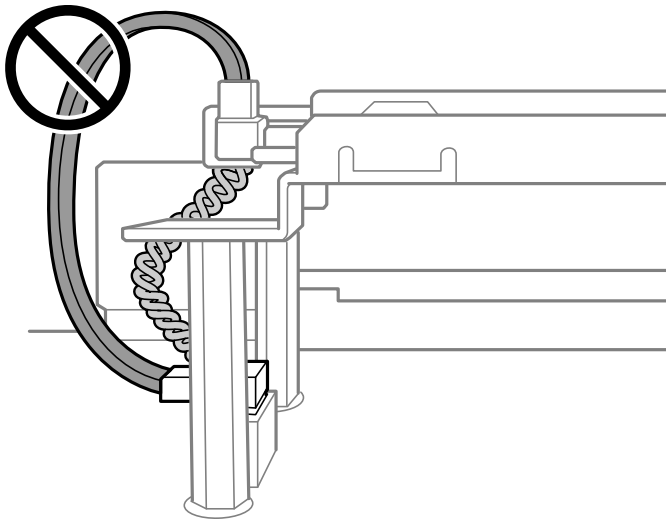
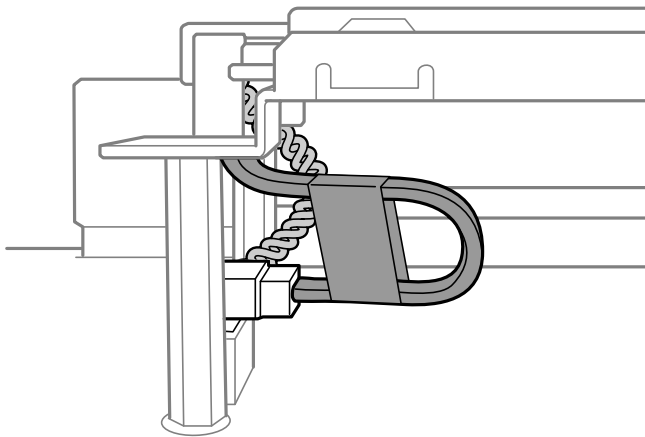

9. Place the HDD by aligning each of the holes with the screw holes on the printer, and then secure the HDD in place with four screws.

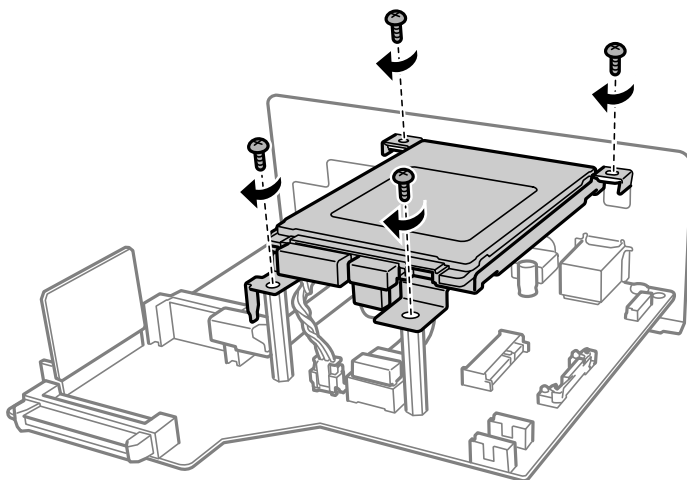

10. Reinsert the additional interface slot and secure it with the four screws.

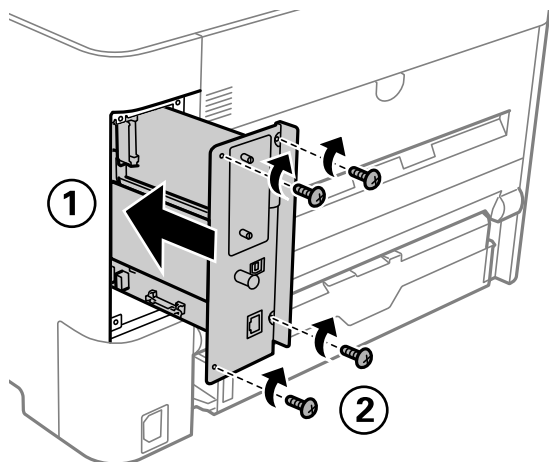

11. Connect the removed power cord and USB cable.
12. After installing the HDD, print a Configuration Status Sheet to check if the HDD is installed correctly.

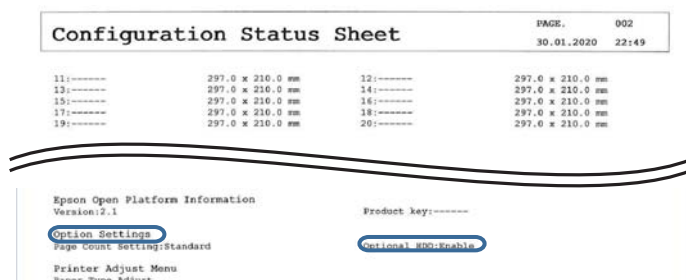

**! Important:**

- Do not remove the installed HDD. If you reinstall it, the data stored in the HDD cannot be guaranteed and may be deleted.
- If you remove the HDD to perform repairs or transport the printer, data could be lost. Make sure you select Option HDD invalid, and then remove the HDD in the reverse order to the installation procedure.

**Related Information**

➔ [“Checking the Installed Optional Items” on page 147](#)

## Setting the HDD in the Printer Driver

The process is the same as for the paper cassette unit.

**Related Information**

➔ [“Setting the Paper Cassette Unit in the Printer Driver” on page 155](#)

## Making Settings for Processing Saved Data

You can make settings for processing data stored in the internal hard disc.

Jobs for printing are temporarily saved to the hard disc in order to handle the data for authenticated printing and the large amount of printing, etc. Make settings to safely erase this data.

### Sequential Deletion from Hard Disk

When enabled, the target data is erased sequentially when it becomes unnecessary, such as when printing is completed. The target to be deleted is data written while this function is enabled.

Because access to the hard disc is necessary, the time to enter power saving mode will be delayed.

### Erase All Memory

Erases all data on the hard disc. You cannot perform other operations or turn off the device during formatting.

- High Speed: Erases all data with a dedicated erase command.
- Overwrite: Erases all data with a dedicated erase command, and overwrites other data in all areas to erase all data.
- Triple Overwrite: Erases all data with a dedicated erase command, and overwrites other data in all areas three times to erase all data.

## Making Settings for Sequential Deletion

### Note:

You can also make settings from the device's control panel.

1. Access Web Config and select the **Device Management > Stored Data**.
2. Select **ON** for **Sequential Deletion from Hard Disk**.
3. Click **OK**.

## Formatting the Internal Hard Disc

1. Select **Settings** on the home screen on the printer's control panel.
2. Select **General Settings > System Administration > HDD Erase Settings**.
3. Select **Erase All Memory**.
4. Select **High Speed**, **Overwrite**, or **Triple Overwrite** according to the purpose.
5. Select **Yes** on the confirmation screen.

## Menu Options for Printing from a Computer (When the HDD is Installed)

If you want to use the HDD, select **Printer Properties > Optional Settings > Printer Information > Manual Settings > Settings > Hard Disk Unit** in the printer driver.

### More Options Tab Windows (When the HDD is Installed)

Job Type:

- Verify Job:** When printing multiple copies, allows you to print one copy to check the content. To print after making the second copy, operate the printer's control panel.

Click **Settings** to set **User Name** and **Job Name**.

- Re-Print Job:** Allows you to store the print job in the printer's memory. You can start printing by operating the printer's control panel.

Click **Settings** to set **User Name** and **Job Name**.

#### Related Information

- ➔ [“More Options Tab” on page 39](#)
- ➔ [“Printing One Copy Before Printing Additional Copies” on page 56](#)
- ➔ [“Storing Print Jobs in the Printer's Memory and Reprinting” on page 57](#)

## Settings Menu List (When the HDD is Installed)

When the HDD is installed, the menu below is displayed on the printer's control panel.

**Settings > General Settings > System Administration**

### HDD Erase Settings:

Make settings for processing data stored in the internal hard disc.

Jobs for printing are temporarily saved to the hard disc in order to handle the data for authenticated printing and the large amount of printing, etc. Make settings to safely erase this data.

Auto Erase Memory Setting:

When enabled, the target data is erased sequentially when it becomes unnecessary, such as when printing is completed. The target to be deleted is data written while this function is enabled.

Because access to the hard disc is necessary, the time to enter power saving mode will be delayed.

Erase All Memory:

Erases all data on the hard disc. You cannot perform other operations or turn off the device during formatting.

- High Speed:**

Erases all data with a dedicated erase command.

Overwrite:

Erases all data with a dedicated erase command, and overwrites other data in all areas to erase all data.

Triple Overwrite:

Erases all data with a dedicated erase command, and overwrites three times other data in all areas to erase all data.

### Option HDD invalid:

Select this setting if you remove the HDD when repairing or transferring the printer.



**Important:**

*Do not remove the installed HDD. If you reinstall it, the data stored in the HDD cannot be guaranteed and may be deleted.*

## Ethernet Board (10/100/1000 Base-T, Ethernet) (AL-M8250DN/AL-M8150DN Only)

### Function List when Using an Additional Network

Functions		Standard	Additional	Related information
Printing	Printing from a computer	✓	✓	
Epson Connect		✓	-	<a href="#">"Printing Using a Cloud Service" on page 88</a>
EPSON Software Updater		✓	-	<a href="#">"Application for Updating Software and Firmware (EPSON Software Updater)" on page 185</a>
Updating firmware		✓	-	<a href="#">"Application for Updating Software and Firmware (EPSON Software Updater)" on page 185</a>
Network settings	Setting an IP address	✓*1	✓*1	<a href="#">"Assigning the IP Address (When Using an Additional Network)" on page 170</a>
	Setting a proxy server	✓	-	<a href="#">"Setting the Proxy Server (When Using an Additional Network)" on page 171</a>
Setting from Web Config		✓*1	✓*1	<a href="#">"Application for Configuring Printer Operations (Web Config)" on page 221</a>
Email notification		✓*2	✓*2	<a href="#">"Configuring a Mail Server" on page 235</a> <a href="#">"Configuring Email Notification (When Using an Additional Network)" on page 172</a>

Functions		Standard	Additional	Related information
Configuring the administrator password		✓*1	✓*1	<a href="#">"Configuring the Administrator Password from the Control Panel" on page 244</a> <a href="#">"Configuring the Administrator Password from a Computer" on page 244</a> <a href="#">"Configuring the Administrator Password for the Additional Network" on page 169</a>
Advanced security settings	IPsec/IP Filtering	✓*1	✓*1	<a href="#">"Encrypted Communication Using IPsec/IP Filtering" on page 268</a>
	IEEE802.1X	✓*1	✓*1	<a href="#">"Connecting the Printer to an IEEE802.1X Network" on page 279</a>

✓ = Available.

- = Not available.

\*1 : You need to make settings for each network.

\*2 : You can use the standard or the additional network to send to recipients for each destination.

## Installing an Ethernet Board



### Caution:

*Make sure you turn off the power, unplug the power cord, and check that all wiring has been disconnected. The cord may be damaged, resulting in electric shock or fire.*



### Important:

- Electrostatic discharge can damage printer parts. Make sure you discharge static electricity from your body by touching grounding yourself before installing the ethernet board.*
- When installing the ethernet board, make sure that the additional interface slot is installed in the printer.*

1. Turn off the printer by pressing the  button.
2. Disconnect all cables such as the power cord and USB cable.

3. Loosen the two screws and then remove the cover.  
Keep the cover in a safe place as you will need it if you remove the ethernet board.

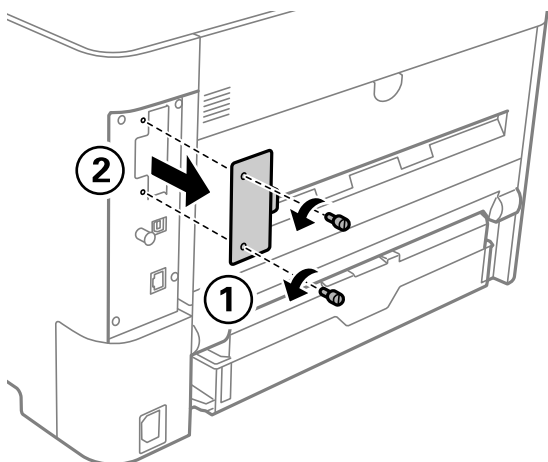

4. Install the ethernet board straight into the additional interface slot for the ethernet board.  
Insert the ethernet board firmly into the slot.

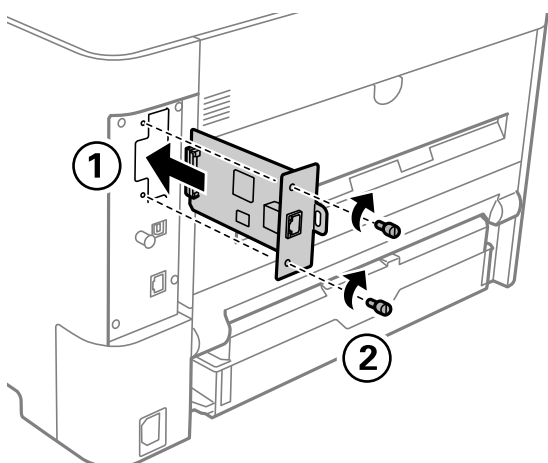

**Important:**

- Do not remove the cover of the ethernet board.
- Do not touch the terminals of the ethernet board.

5. Secure the ethernet board with the two screws.
6. Connect the removed power cord and USB cable.



- After installing the ethernet board, print a Configuration Status Sheet to check if the board is installed correctly.

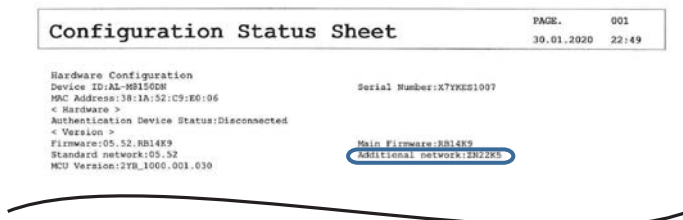

### Related Information

- ➔ [“Checking the Installed Optional Items” on page 147](#)

## Settings when Using an Additional Network

### Administrator Password Setting for Additional Network

When you set an administrator password for the additional network, you can prevent users from changing additional network settings. You can set and change the administrator password for the additional network using Web Config from a computer on the additional network. The administrator password for the additional network and for the printer are different.

The initial password for the additional network is the last eight digits of the MAC address. To check this, select **Wired LAN Status** for the additional network on the printer's control panel to display the details. You can also confirm the MAC address on the label stuck to the Ethernet board.

We recommend that you change the initial password as soon as possible to prevent unauthorized access. If you reset the additional network to the default settings, the initial password will be restored.

### Related Information

- ➔ [“Menu Options for Network Settings \(When Using an Additional Network\)” on page 173](#)

### Configuring the Administrator Password for the Additional Network

You can set the administrator password using Web Config from a computer on the additional network.

- Enter the printer's IP address for the additional network into a browser to access Web Config.
- Select the **Product Security** tab > **Change Administrator Password**.
- Enter a password to **New Password** and **Confirm New Password**. Enter the user name, if necessary.  
If you want to change the password to new one, enter a current password.
- Select **OK**.

**Note:**

To set or change the locked menu items, click **Administrator Login**, and then enter the administrator password.

## Related Information

➔ [“Application for Configuring Printer Operations \(Web Config\)” on page 221](#)

## Connecting to the Network from the Control Panel (When Using an Additional Network)

Connect the printer to the network by using the printer's control panel.

### **Assigning the IP Address (When Using an Additional Network)**

Set up the basic items such as Host Address, Subnet Mask, Default Gateway.

Make settings for the standard and the additional network.

This section explains the procedure for setting a static IP address.

1. Turn on the printer.
2. Select **Settings** on the home screen on the printer's control panel.
3. Select **General Settings > Network Settings**.
4. Select **Standard** or **Additional** for the network that you want to set up.
5. Select **Advanced > TCP/IP**.

**Note:**

*When you select **Advanced**, you need to enter the administrator password for the additional network.*

6. Select **Manual** for **Obtain IP Address**.

When you set the IP address automatically by using the DHCP function of router, select **Auto**. In that case, the **IP Address**, **Subnet Mask**, and **Default Gateway** on step 7 to 8 are also set automatically, so go to step 9.

7. Enter the IP address.

Focus moves to the forward segment or the back segment separated by a period if you select ◀ and ▶.

Confirm the value reflected on the previous screen.

8. Set up the **Subnet Mask** and **Default Gateway**.

Confirm the value reflected on the previous screen.



**Important:**

*If the combination of the IP Address, Subnet Mask and Default Gateway is incorrect, **Start Setup** is inactive and cannot proceed with the settings. Confirm that there is no error in the entry.*

9. Enter the IP address for the primary DNS server.

Confirm the value reflected on the previous screen.

**Note:**

When you select **Auto** for the IP address assignment settings, you can select the DNS server settings from **Manual** or **Auto**. If you cannot obtain the DNS server address automatically, select **Manual** and enter the DNS server address. Then, enter the secondary DNS server address directly. If you select **Auto**, go to step 11.

10. Enter the IP address for the secondary DNS server.  
Confirm the value reflected on the previous screen.
11. Select **Start Setup**.

### Setting the Proxy Server (When Using an Additional Network)

Set up the proxy server if both of the following are true.

- The proxy server is built for Internet connection.
- When using a function in which a printer directly connects to the Internet, such as Epson Connect service or another company's cloud services.

The proxy server is only available on the standard network.

1. Select **Settings** on the home screen.  
When making settings after IP address setting, the **Advanced** screen is displayed. Go to step 3.
2. Select **General Settings** > **Network Settings** > **Standard** > **Advanced**.
3. Select **Proxy Server**.
4. Select **Use** for **Proxy Server Settings**.
5. Enter the address for the proxy server by IPv4 or FQDN format.  
Confirm the value reflected on the previous screen.
6. Enter the port number for the proxy server.  
Confirm the value reflected on the previous screen.
7. Select **Start Setup**.

### Connecting to Ethernet (When Using an Additional Network)

#### Connecting to Ethernet on the Standard Network

Connect the printer to the standard network by using an Ethernet cable, and then check the connection.

1. Connect the printer and hub (LAN switch) by Ethernet cable.
2. Select **Settings** on the home screen.

3. Select **General Settings > Network Settings > Standard > Connection Check**.

The connection diagnosis result is displayed. Confirm the connection is correct.

4. Select **Dismiss** to finish.

When you select **Print Check Report**, you can print the diagnosis result. Follow the on-screen instructions to print it.

### **Connecting to Ethernet on an Additional Network**

Connect the printer to the additional network by using an Ethernet cable, and then check the connection.

1. Connect the printer and hub (LAN switch) by Ethernet cable.
2. Check that the lights for the LAN port for the additional network are flashing.

## **Receiving Email Notifications When Events Occur (When Using an Additional Network)**

### **About Email Notifications (When Using an Additional Network)**

This is the notification function that, when events such as printing stop and printer error occur, send the email to the specified address.

You can register up to five destinations and set the notification settings for each destination.

To use this function, you need to set up the mail server before setting up notifications. Set up the email server on the network (standard or additional) to which you want to send the email.

### **Related Information**

➔ [“Configuring a Mail Server” on page 235](#)

### **Configuring Email Notification (When Using an Additional Network)**

Configure email notification by using Web Config from a computer on the standard network.

1. Enter the printer's IP address for the standard network into a browser to access Web Config.

2. Select the **Device Management** tab > **Email Notification**.

3. Set the subject of email notification.

Select the contents displayed on the subject from the two pull-down menus.

The selected contents are displayed next to **Subject**.

The same contents cannot be set on left and right.

When the number of characters in **Location** exceeds 32 bytes, characters exceeding 32 bytes are omitted.

4. Enter the email address for sending the notification email.  
Use A-Z a-z 0-9 ! # \$ % & ' \* + - . / = ? ^ \_ { | } ~ @, and enter between 1 and 255 characters.
5. Select **Standard** or **Additional** for the network used to send to recipients.
6. Select the language for the email notifications.
7. Select the check box on the event for which you want to receive a notification.  
The number of **Notification Settings** is linked to the destination number of **Email Address Settings**.  
Example :  
If you want a notification sent to the email address set for number 1 in **Email Address Settings** when the printer is out of paper, select the check box column **1** in line **Paper out**.
8. Click **OK**.  
Confirm that an email notification will be sent by causing an event.  
Example : Print by specifying the Paper Source where paper is not set.

#### Related Information

- ➔ [“Application for Configuring Printer Operations \(Web Config\)” on page 221](#)
- ➔ [“Configuring a Mail Server” on page 235](#)
- ➔ [“Items for Email Notification” on page 253](#)

## Solving Problems when Using an Additional Network

### Cannot Print from a Computer

**The standard or additional network settings are incorrect.**

You need to set up the standard network and the additional network. Check the settings for both networks.

#### Related Information

- ➔ [“Connecting to the Network from the Control Panel \(When Using an Additional Network\)” on page 170](#)

## Menu Options for Network Settings (When Using an Additional Network)

This section explains the Network Settings menu when using the additional network.

Select the menus on the control panel as described below.

**Settings > General Settings > Network Settings**

## Standard:

Set up the standard network. See Related Information below.

### Related Information

➔ [“Network Settings” on page 191](#)

## Additional:

Set up the additional network.

### Network Status:

Displays or prints the current network settings.

- Wired LAN Status
- Print Status Sheet

### Advanced:

Make the following detailed settings.

- TCP/IP
- IPv6 Address
- Link Speed & Duplex
- Redirect HTTP to HTTPS
- Disable IPsec/IP Filtering
- Disable IEEE802.1X

You need to enter the administrator password for the additional network.

### Restore Default Settings:

Reset the settings for the additional network to their defaults.

You need to enter the administrator password for the additional network.

## Network Transmission Route:

This menu is unavailable.

## LDAP Server:

This menu is unavailable.

---

# Product Information

Paper Information. . . . .	176
Consumable Products Information. . . . .	179
Software Information. . . . .	179
Settings Menu List. . . . .	186
Product Specifications. . . . .	195
Font Specifications. . . . .	204
Regulatory Information. . . . .	219

# Paper Information

## Available Paper and Capacities

### Available Paper and Capacities

Using paper other than the paper below may cause paper jams or damage to the printer. Make sure you perform a test print before using paper with large variations in quality such as recycled paper or envelopes.

Even if the paper thickness is available, print quality may decline or paper jams may occur depending on the paper quality (paper grain, hardness, and so on).

**Note:**

See the following for information on available paper types for 2-sided printing.

[“Paper for Automatic 2-Sided Printing” on page 178](#)

**Note:**

- Paper cassette 5 is only for AL-M8250DN and AL-M8150DN.
- Envelopes are printed at a slower speed than plain paper, to get better print quality.
- If you select **Auto Select** in **Paper Source** in the printer driver, the printer will search for a paper source containing the paper size specified in **Document Size**, and prints from the paper source until there is no more paper, then it prints from the next paper source automatically. Using this auto select function, for plain paper (80g/m<sup>2</sup>), the printer can continuously print up to 2600 sheets (for AL-M8250DN and AL-M8150DN), or up to 2100 sheets (for AL-M7150DN).
- The output tray capacity for plain paper is as follows:  
 up to 550 sheets for face-down tray (standard output tray)  
 up to 250 sheets for face-up tray (optional output tray)
- Select the size of the paper that is loaded on the paper size setting dial on the paper cassette. If the paper size is not on the dial, select **Panel** on the dial, and set the paper size on the control panel.

### Plain papers (60 to 80g/m<sup>2</sup>)\*1, Semi-thick paper (75 to 120g/m<sup>2</sup>), Special paper

Plain paper includes preprinted paper (60 to 75g/m<sup>2</sup>)\*2, letterhead (90 to 120g/m<sup>2</sup>), color paper (90 to 120g/m<sup>2</sup>), recycled paper (60 to 80g/m<sup>2</sup>)\*3.

- \*1 For paper less than 64g/m<sup>2</sup> set the paper type to **Thin** on the control panel and in the printer driver.
- \*2 Paper on which various forms are pre-printed such as slips.
- \*3 Use only at normal temperature (15 to 25°C) and humidity (40 to 60%). Poor quality paper may reduce print quality, or cause paper jams and other problems.

Size	Loading Capacity (Sheets)		
	Paper Cassette 1	Paper Cassette 2 to 5	Paper Tray
A3, B4, US B (11×17 in.)	500	500	50
A4, A5 Portrait, B5, Half Letter, Executive, 8×10.5 in., 8.27×13 in., Letter, 8.5×13 in., Legal, SP1 (210×270 mm)	500	500	100*1



Size	Loading Capacity (Sheets)		
	Paper Cassette 1	Paper Cassette 2 to 5	Paper Tray
A5 Landscape, A6, SP2 (210×149 mm)	300*2	-	100
SP3 (100×170mm)	-	-	100
SP4 (130×182 mm)	500	-	100
User Defined Width: 148 to 297mm Length: 182 to 431.8mm	-	500	-
User Defined Width: 105 to 297mm Length: 148 to 431.8mm	500	-	-
User Defined Width: 70 to 297mm Length: 148 to 450mm	-	-	100*3

\*1 The loading capacity for A4 size paper (60g/m<sup>2</sup> to 64g/m<sup>2</sup>) is 120 sheets.

\*2 The loading capacity for paper smaller than A5 landscape and A6 size is 300 sheets.

\*3 The loading capacity for paper longer than B4 (364 mm) is 50 sheets.

### Thick paper (120 to 220g/m<sup>2</sup>)

Select **Thick paper1** for thick paper (120 to 135g/m<sup>2</sup>), **Thick paper2** for thick paper (135 to 170g/m<sup>2</sup>), or **Thick paper3** for thick paper (170 to 220g/m<sup>2</sup>) as the paper type setting.

Size	Loading Capacity (Thickness)		
	Paper Cassette 1	Paper Cassette 2 to 5	Paper Tray
A3, A4, A5, A6, B5, B4, Half Letter, Executive, 8×10.5 in., 8.27×13 in., Letter, 8.5×13 in., Legal, US B (11×17 in.)  User Defined Width: 70 to 297mm Length: 148 to 450mm	-	-	5.5mm

### Labels

Size	Loading Capacity (Sheets)		
	Paper Cassette 1	Paper Cassette 2 to 5	Paper Tray
A4, Letter	-	-	30

## Transparencies

Size	Loading Capacity (Sheets)		
	Paper Cassette 1	Paper Cassette 2 to 5	Paper Tray
A4, Letter	-	-	5

## Envelope

Size	Loading Capacity (Sheets)		
	Paper Cassette 1	Paper Cassette 2 to 5	Paper Tray
Monarch Envelope #10 Envelope DL Envelope C6 Envelope C5 Envelope B5	-	-	5

## Paper for Automatic 2-Sided Printing

Plain paper, Semi-thick paper\*

\* Except A5 landscape, A6, SP2, SP3, and SP4 size.

For automatic 2-sided printing with User Defined paper sizes, you can use 148 to 297 x 182 to 431.8 mm paper sizes.

## Related Information

➔ [“Available Paper and Capacities” on page 176](#)

## Unavailable Paper Types

Do not use the following papers. Using these types of paper causes paper jams and smears on the printout.

- Media meant for other color laser printers, black-and-white laser printers, color copiers, black-and-white copiers, or ink jet printers
- Previously printed paper by any other color laser printers, black-and-white laser printers, color copiers, black-and-white copiers, ink jet printers, or thermal transfer printers
- Paper that has already been printed on with special ink
- Very thin paper (59g/m<sup>2</sup> or less), or very thick paper (221g/m<sup>2</sup> or more)
- Carbon paper, carbonless paper, thermal-sensitive paper, pressure-sensitive paper, acid paper, or paper that uses high-temperature-sensitive ink (around 175 °C)
- Labels that peel easily or labels that do not cover the backing sheet completely
- Special surface-coated paper or special surface-colored paper
- Paper that has binder holes or is perforated
- Paper that has glue, staples, paper clips, or tape on it

- Paper that attracts static electricity
- Moist or damp paper
- Paper of uneven thickness
- Overly thick or thin paper
- Paper that is too smooth or too rough
- Paper that is different on the front and back
- Paper that is folded, curled, wavy, or torn
- Paper of irregular shape, or paper that does not have right angle corners

Do not use the following envelopes. Using these types of envelope causes paper jams and smears on the printout.

- Envelopes that have glue or tape
- Envelopes that have plastic windows

## Consumable Products Information

### Consumable Products Code

A waste toner collector is supplied with the toner cartridge. Replace the waste toner collector when replacing the toner cartridge.

#### For AL-M8250DN and AL-M8150DN

Product name	Part number	Remark
STANDARD CAPACITY TONER CARTRIDGE BLACK *	10141	<input type="checkbox"/> Storage temperature: 0 to 35°C (32 to 95°F) <input type="checkbox"/> Storage humidity: 15 to 80% RH
HIGH CAPACITY TONER CARTRIDGE BLACK	10142	

\* Support only for AL-M8250DN

#### For AL-M7150DN

Product name	Part number	Remark
STANDARD CAPACITY TONER CARTRIDGE BLACK	10141	<input type="checkbox"/> Storage temperature: 0 to 35°C (32 to 95°F) <input type="checkbox"/> Storage humidity: 15 to 80% RH

## Software Information

This section introduces the network services and software products available for your printer from the Epson website.

## Software for Printing

### Application for Printing from a Computer (Windows Printer Driver)

The printer driver controls the printer according to the commands from an application. Making settings on the printer driver provides the best printing results. You can check the status of the printer using the printer driver utility.

**Note:**

You can change the language of the printer driver. Select the language you want to use from the **Language** setting on the **Maintenance** tab.

#### Accessing the printer driver from applications

To make settings that apply only to the application you are using, access from that application.

Select **Print** or **Print Setup** from the **File** menu. Select your printer, and then click **Preferences** or **Properties**.

**Note:**

Operations differ depending on the application. See the application's help for details.

#### Accessing the printer driver from the control panel

To make settings that apply to all of the applications, access from the control panel.

Windows 10/Windows Server 2019/Windows Server 2016

Click on the start button, and then select **Windows System > Control Panel > View devices and printers in Hardware and Sound**. Right-click on your printer, or press and hold it and then select **Printing preferences**

Windows 8.1/Windows 8/Windows Server 2012 R2/Windows Server 2012

Select **Desktop > Settings > Control Panel > View devices and printers in Hardware and Sound**. Right-click on your printer, or press and hold it and then select **Printing preferences**

Windows 7/Windows Server 2008 R2

Click the start button, and select **Control Panel > View devices and printers in Hardware and Sound**. Right-click on your printer and select **Printing preferences**.

Windows Vista/Windows Server 2008

Click the start button, and select **Control Panel > Printers in Hardware and Sound**. Right-click on your printer and select **Printing preferences**.

Windows XP/Windows Server 2003 R2/Windows Server 2003

Click the start button, and select **Control Panel > Printers and Other Hardware > Printers and Faxes**. Right-click on your printer and select **Printing preferences**.

#### Accessing the printer driver from the printer icon on the task bar

The printer icon on the desktop task bar is a shortcut icon allowing you to quickly access the printer driver.

If you click the printer icon and select **Printer Settings**, you can access the same printer settings window as the one displayed from the control panel. If you double-click this icon, you can check the status of the printer.

**Note:**

If the printer icon is not displayed on the task bar, access the printer driver window, click **Monitoring Preferences** on the **Maintenance** tab, and then select **Register the shortcut icon to the taskbar**.

### Starting the utility

Access the printer driver window. Click the **Maintenance** tab.

### Related Information

➔ [“Menu Options for the Printer Driver” on page 37](#)

## Guide to Windows Printer Driver

### EPSON Status Monitor

You can use this utility to monitor the status of your printer and display error messages and more. You can also check the status of consumables and the progress of printing. You need to install this software to use it.

### Related Information

➔ [“Installing the Applications Separately” on page 96](#)

## Application for Printing from a Computer (Mac OS Printer Driver)

The printer driver controls the printer according to the commands from an application. Making settings on the printer driver provides the best printing results. You can check the status of the printer using the printer driver utility.

### Accessing the printer driver from applications

Click **Page Setup** or **Print** on the **File** menu of your application. If necessary, click **Show Details** (or ▼) to expand the print window.

**Note:**

*Depending on the application being used, **Page Setup** may not be displayed in the **File** menu, and the operations for displaying the print screen may differ. See the application's help for details.*

### Starting the utility

Select **System Preferences** from the Apple menu > **Printers & Scanners** (or **Print & Scan**, **Print & Fax**), and then select the printer. Click **Options & Supplies** > **Utility** > **Open Printer Utility**.

### Related Information

➔ [“Menu Options for the Printer Driver” on page 69](#)

## Guide to Mac OS Printer Driver

### Epson Printer Utility

You can start **EPSON Status Monitor** and check the printer status and error information.

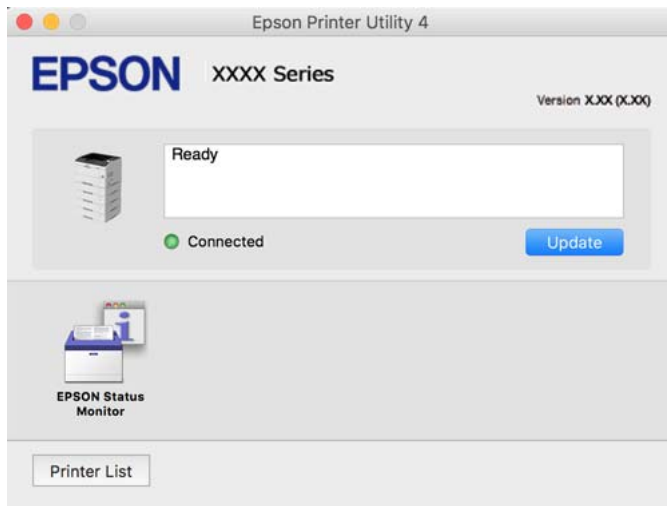

## Application that can print PostScript Fonts (Windows PostScript Printer Driver)

The PostScript printer driver allows the printer to receive and interpret print instructions in the page description language sent from the computer and print properly. This is suitable for printing from PostScript compliant applications used for DTP.

### Accessing the printer driver from applications

To make settings that apply only to the application you are using, access from that application.

Select **Print** or **Print Setup** from the **File** menu. Select your printer, and then click **Preferences** or **Properties**.

#### Note:

*Operations differ depending on the application. See the application's help for details.*

### Accessing the printer driver from the control panel

To make settings that apply to all of the applications, access from the control panel.

#### Windows 10/Windows Server 2019/Windows Server 2016

Click on the start button, and then select **Windows System > Control Panel > View devices and printers in Hardware and Sound**. Right-click on your printer, or press and hold it and then select **Printing preferences**

#### Windows 8.1/Windows 8/Windows Server 2012 R2/Windows Server 2012

Select **Desktop > Settings > Control Panel > View devices and printers in Hardware and Sound**. Right-click on your printer, or press and hold it and then select **Printing preferences**

#### Windows 7/Windows Server 2008 R2

Click the start button, and select **Control Panel > View devices and printers in Hardware and Sound**. Right-click on your printer and select **Printing preferences**.

❑ Windows Vista/Windows Server 2008

Click the start button, and select **Control Panel > Printers** in **Hardware and Sound**. Right-click on your printer and select **Printing preferences**.

❑ Windows XP/Windows Server 2003 R2/Windows Server 2003

Click the start button, and select **Control Panel > Printers and Other Hardware > Printers and Faxes**. Right-click on your printer and select **Printing preferences**.

### Accessing the printer driver from the printer icon on the task bar

The printer icon on the desktop task bar is a shortcut icon allowing you to quickly access the printer driver.

If you click the printer icon and select **Printer Settings**, you can access the same printer settings window as the one displayed from the control panel. If you double-click this icon, you can check the status of the printer.

### Related Information

➔ [“Menu Options for the PostScript Printer Driver” on page 64](#)

## Application that can print PostScript Fonts (Mac OS PostScript Printer Driver)

The PostScript printer driver allows the printer to receive and interpret print instructions in the page description language sent from the computer and print properly. This is suitable for printing from PostScript compliant applications used for DTP.

### Accessing the printer driver from applications

Click **Page Setup** or **Print** on the **File** menu of your application. If necessary, click **Show Details** (or ▼) to expand the print window.

**Note:**

*Depending on the application being used, **Page Setup** may not be displayed in the **File** menu, and the operations for displaying the print screen may differ. See the application's help for details.*

### Starting the utility

Select **System Preferences** from the Apple menu > **Printers & Scanners** (or **Print & Scan, Print & Fax**), and then select the printer. Click **Options & Supplies > Utility > Open Printer Utility**.

### Related Information

➔ [“Menu Options for the PostScript Printer Driver” on page 81](#)

## Application that can print PCL Language (PCL Printer Driver)

The PCL Printer Driver allows the printer to receive and interpret print instructions in the page description language sent from the computer and print properly. This is suitable for printing from general applications such as Microsoft Office.

**Note:**

*Mac OS is not supported.*

Connect the printer to the same network as the computer, and then follow the procedure below to install the printer driver.

1. Download the executable file of the driver from the Epson support website.

<http://www.epson.eu/Support> (Europe only)

<http://support.epson.net/>

2. Double-click the executable file.
3. Follow the on-screen instructions for the rest of the installation.

**Note:**

*If you are using a Windows computer and you cannot download the driver from the website, install it from the software disc that came with the printer. Access "Driver\PCL Universal".*

## Application that Prints Using a Method that is not Standard on Windows (EpsonNet Print)

EpsonNet Print is a software to print on the TCP/IP network. This is installed from the installer together with the printer driver. To perform network printing, create an EpsonNet Print port. There are features and restrictions listed below.

- The printer's status is displayed on the spooler screen.
- If the printer's IP address is changed by DHCP, the printer is still detected.
- You can use a printer located on a different network segment.
- You can print using one of the various protocols.
- IPv6 address is not supported.

## Application for Printing Easily from a Smart Device (Epson iPrint)

Epson iPrint is an application that allows you to print photos, documents, and web pages from a smart device such as a smartphone or tablet. You can use local print, printing from a smart device that is connected to the same network as the wireless router, or remote print, printing from a remote location over the Internet. To use remote print, register your printer in the Epson Connect service.

When the wireless router is connected to the same network as the printer, you can operate the printer via the wireless router from your smart device.



### Installing Epson iPrint

You can install Epson iPrint on your smart device from the following URL or QR code.



<http://ipr.to/c>



## Application for Printing Easily from an Android Application (Epson Print Enabler)

Epson Print Enabler is an application that allows you to wirelessly print your documents, emails, photos, and web pages right from your Android phone or tablet (Android v4.4 or later). With a few taps, your Android device will discover an Epson printer that is connected to the same wireless network.

When the wireless router is connected to the same network as the printer, you can operate the printer via the wireless router from your smart device.

Search for and install Epson Print Enabler from Google Play.

## Software for Package Creation

### Application for Creating Driver Packages (EpsonNet SetupManager)

EpsonNet SetupManager is a software to create a package for a simple printer installation, such as installing the printer driver, installing EPSON Status Monitor and creating a printer port. This software allows the administrator to create unique software packages and distribute them among groups.

For more information, visit your regional Epson website.

<http://www.epson.com>

## Software for Updating

### Application for Updating Software and Firmware (EPSON Software Updater)

EPSON Software Updater is an application that installs new software, and updates firmware over the Internet. If you want to check for update information regularly, you can set the interval for checking for updates in EPSON Software Updater's Auto Update Settings.

**Note:**

*Windows Server operating systems are not supported.*

#### Starting on Windows

Windows 10

Click the start button, and then select **Epson Software > EPSON Software Updater**.

Windows 8.1/Windows 8

Enter the application name in the search charm, and then select the displayed icon.

- Windows 7/Windows Vista/Windows XP

Click the start button, and then select **All Programs** (or **Programs**) > **Epson Software** > **EPSON Software Updater**.

**Note:**

*You can also start EPSON Software Updater by clicking the printer icon on the task bar on the desktop, and then selecting Software Update.*

### Starting on Mac OS

Select **Go** > **Applications** > **Epson Software** > **EPSON Software Updater**.

### Related Information

➔ [“Installing the Applications Separately” on page 96](#)

---

## Settings Menu List

Select **Settings** on the home screen of the printer to make various settings.

### General Settings

Select the menus on the control panel as described below.

**Settings** > **General Settings**

### Basic Settings

Select the menus on the control panel as described below.

**Settings** > **General Settings** > **Basic Settings**

You cannot change settings that have been locked by your administrator.

#### LCD Brightness:

Adjust the brightness of the LCD screen.

#### Sound:

Adjust the volume.

- Mute

Select **On** to mute sounds such as those emitted by **Button Press**.

- Normal Mode

Select the volume such as **Button Press**.

#### Sleep Timer:

Adjust the time period to enter a sleep mode (energy saving mode) when the printer has not performed any operations. The LCD screen turns black when the setting time passes.

#### Quick Sleep:

You can save more power by switching to the energy saving state immediately after printing. Select Off to turn it off.

#### Power Off If Disconnected:

Select this setting to turn the printer off after 30 minutes when all ports including the USB port are disconnected. This feature may not be available depending on your region.

#### Date/Time Settings:

Date/Time

Enter the current date and time.

Daylight Saving Time

Select the summer time setting that applies to your area.

Time Difference

Enter the time difference between your local time and UTC (Coordinated Universal Time).

#### Language:

Select the language used on the LCD screen.

#### Operation Time Out:

Select **On** to return to the initial screen when no operations have been performed for the specified time.

#### Keyboard:

Change the layout of the keyboard on the LCD screen.

#### Related Information

➔ [“Entering Characters” on page 28](#)

## Printer Settings

Select the menus on the control panel as described below.

### Settings > General Settings > Printer Settings

You cannot change settings that have been locked by your administrator.

#### Paper Source Settings:

##### Paper Setting:

Select the paper size and paper type you loaded in the paper source.

##### Paper Tray Priority:

Select **On** to give printing priority to paper loaded in the paper tray.

#### A4/Letter Auto Switching:

Select **On** to feed paper from the paper source set as A4 size when there is no paper source set as Letter, or feed from the paper source set as Letter size when there is no paper source set as A4.

#### Auto Select Settings:

Select **On** for settings to automatically print on paper from any sources containing paper that matches your paper settings.

#### Error Tone:

Select **On** to display an error message with an error sound when the selected paper size or type does not match the loaded paper.

#### Paper Setup Auto Display:

Select **On** to display the **Paper Setting** screen when loading paper in the paper cassette. If you disable this feature, you cannot print from an iPhone, iPad, or iPod touch using AirPrint.

#### User-Defined Paper Size List:

You can change the user defined size setting. This is useful when you print frequently on irregularly sized paper.

#### Output Tray:

Select which output tray to use to catch paper when it is ejected after printing. If you select **Face Up Tray** as the output tray, install the optional face up tray.

#### Printing Language:

Select the printing language for the USB interface or the network interface.

#### Universal Print Settings:

These print settings are applied when you print by an external device without using the printer driver. The offset settings are applied when you print using the printer driver.

#### Top Offset:

Adjust the top margin of the paper.

#### Left Offset:

Adjust the left margin of the paper.

#### Top Offset in Back:

Adjust the top margin for the back of the page when performing 2-sided printing.

#### Left Offset in Back:

Adjust the left margin for the back of the page when performing 2-sided printing.

#### Skip Blank Page:

Skips blank pages in the print data automatically to save paper.

#### PDL Print Configuration:

Select the options you want to use for printing.

### Common Settings:

- Paper Size  
Select the default paper size for printing.
- Paper Type  
Select the default paper type for printing.
- Orientation  
Select the default orientation for printing.
- Quality  
Select the print quality for printing.
- Toner Save Mode  
Select **On** to save toner by reducing the print density.
- Print Order  
Last Page on Top  
Starts printing from the first page of a file.  
First Page on Top  
Starts printing from the last page of a file.
- Number of Copies  
Set the number of copies to print.
- Binding Margin  
Select the binding position.
- Auto Paper Ejection  
Select **On** to eject paper automatically when printing is stopped during a print job.
- 2-Sided Printing  
Select **On** to perform 2-sided printing.
- Convert to Simplex  
In the duplex printing mode, specifies whether to print the last page of a job in one side printing mode. Select **Off** to print the final page on the appropriate side.
  - Odd Page: 1-page jobs or the last page of a job with an odd number of pages are printed in one side printing mode.
  - 1 Page: 1-page jobs are printed in one side printing mode.
  - Off: The last page of all jobs (including 1-page jobs or jobs with an odd number of pages) is printed in duplex printing mode.
- RITech  
Select **On** to produce smoother and crisper lines, text, and graphics.
- Wide A4  
Select **On** to decrease the left and right margins to 3.4 mm.
- Extend Print Area  
Makes the maximum print area larger according to the printed data.
- Density  
Adjust the printing density.

#### PCL Menu:

- Font Source
  - Resident  
Select to use a font preinstalled on the printer.
  - Download  
Select to use a font you have downloaded.
- Font Number  
Select the default font number for the default Font Source. The available number varies depending on the settings you made.
- Pitch  
Set the default font pitch if the font is scalable and of fixed-pitch. You can select from 0.44 to 99.99 cpi (characters per inch), in 0.01 increments.  
This item may not appear depending on the Font Source or Font Number settings.
- Height  
Set the default font height if the font is scalable and proportional. You can select from 4.00 to 999.75 points, in 0.25 increments.  
This item may not appear depending on the Font Source or Font Number settings.
- Symbol Set  
Select the default symbol set. If the font that you selected in the Font Source and the Font Source setting is not available in the new symbol set setting, the Font Source and the Font Number settings are automatically replaced with the default value, IBM-US.
- Form  
Set the number of lines for the selected paper size and orientation. This also causes a line spacing (VMI) change, and the new VMI value is stored in the printer. This means that later changes in the page size or orientation settings cause changes in the Form value based on the stored VMI.
- CR Function  
Select the line feed command when printing with a driver from a specific operating system.
- LF Function  
Select the line feed command when printing with a driver from a specific operating system.
- Paper Source Assign  
Set the assignment for the paper source select command. When **4** is selected, the commands are set as compatible with the HP LaserJet 4. When **4K** is selected, the commands are set as compatible with the HP LaserJet 4000, 5000, and 8000. When **5S** is selected, the commands are set as compatible with the HP LaserJet 5S.

#### PS Menu:

- Error Sheet  
Select **On** to print a sheet showing the status when an error occurs during PostScript or PDF printing.
- Binary  
Select **On** when printing data that contains binary images. The application may send the binary data even if the printer driver setting is set to ASCII, but you can print the data when this feature is enabled.

PDF Page Size

Select the paper size when printing a PDF file. If **Auto** is selected, the paper size is determined based on the size of the first page.

Auto Error Solver:

Select an action to perform when a 2-sided printing error or a memory full error occurs.

On

Displays a warning and prints in single-sided mode when a 2-sided printing error occurs, or prints only what the printer could process when a memory full error occurs.

Off

Displays an error message and cancels printing.

PC Connection via USB:

Select **Enable** to allow a computer to access the printer when connected by USB. When **Disable** is selected, printing that is not sent over a network connection is restricted.

USB I/F Timeout Setting:

Specify the length of time in seconds that must elapse before ending USB communication with a computer after the printer receives a print job from a PostScript printer driver or PCL printer driver. If the job ending is not clearly defined from a PostScript printer driver or PCL printer driver, it can cause endless USB communication. When this occurs, the printer ends communication after the specified time has elapsed. Enter 0 (zero) if you do not want to end communication.

Printer Swapping:

If you select On, the USB device ID is fixed and the plug and play screen will not be displayed when the printer is replaced.

## Network Settings

Select the menus on the control panel as described below.

### Settings > General Settings > Network Settings

Network Status:

Displays or prints the current network settings.

Wired LAN Status

Print Status Sheet

Connection Check:

Checks the current network connection and prints a report. If there are any problems with the connection, see the report to solve the problem.

Advanced:

Make the following detailed settings.

Device Name

TCP/IP

Proxy Server

- IPv6 Address
- Link Speed & Duplex
- Redirect HTTP to HTTPS
- Disable IPsec/IP Filtering
- Disable IEEE802.1X

### Related Information

- ➔ [“Printing a Network Connection Report” on page 138](#)
- ➔ [“Checking the Network Connection Status” on page 137](#)

## Web Service Settings

Select the menus on the control panel as described below.

**Settings > General Settings > Web Service Settings**

You cannot change settings that have been locked by your administrator.

### Epson Connect Services:

Displays whether the printer is registered and connected to Epson Connect.

You can register to the service by selecting **Register** and follow the instructions.

When you have registered, you can change the following settings.

- Suspend/Resume
- Unregister

For details, see the following web site.

<https://www.epsonconnect.com/>

<http://www.epsonconnect.eu> (Europe only)

## System Administration

By using this menu, you can maintain the product as a system administrator. It also allows you to restrict product features for individual users to suite your work or office style.

Select the menus on the control panel as described below.

**Settings > General Settings > System Administration**

### Reset number of consumed toner:

This feature is only available on AL-M8250DN/AL-M8150DN.

You can reset the amount of consumed toner to the default.

### Clear Internal Memory Data:

This item is displayed on PCL or PostScript compatible printer.

Delete the printer's internal memory data, such as a downloaded font and macro for PCL printing.



### Security Settings:

You can make the following security settings.

#### Delete All Internal Memory Jobs:

Delete all internal memory jobs.

#### Admin Settings:

Admin Password

Set, change, and clear an administrator password.

Lock Setting

Select whether or not to lock the control panel using the password registered in **Admin Password**.

#### Password Encryption:

Select **On** to encrypt your password. If you turn off the power while the restart is in progress, data may be corrupted and the printer settings will be restored to their defaults. If this occurs, set the password information again.

#### Audit Log:

Select **On** to record an audit log.

#### Customer Research:

Select **Approve** to provide product usage information such as the number of prints to Seiko Epson Corporation.

#### Printer Adjust Menu:

You can make special settings for the printer.

#### Restore Default Settings:

Reset the settings in the following menus to their defaults.

Network Settings

All Except Network Settings

All Settings

#### Firmware Update:

You can get firmware information such as your current version and information on available updates.

#### Update:

Check if the latest version of the firmware has been uploaded to the network server. If an update is available, you can select whether or not to start updating.

#### Notification:

Select **On** to receive a notification if a firmware update is available.

### Related Information

➔ [“Printer Adjust Menu” on page 201](#)

## Print Counter

Select the menus on the control panel as described below.

### Settings > Print Counter

Displays the total number of prints including items such as the status sheet from the time you purchased the printer.

## Replacement Parts

Select the menus on the control panel as described below.

### Settings > Replacement Parts

You can check the status and code of consumables and replacement parts.

## Language

Select the menus on the control panel as described below.

### Settings > Language

Select the language used on the LCD screen.

## Printer Status/Print

Select the menus on the control panel as described below.

### Settings > Printer Status/Print

Print Status Sheet:

Configuration Status Sheet:

Print information sheets showing the current printer status and settings.

Supply Status Sheet:

Print information sheets showing the status of consumables.

Usage History Sheet:

Print information sheets showing the usage history of the printer.

PS Font List:

Print a list of fonts that are available for a PostScript printer.

PCL Font List:

Print a list of fonts that are available for a PCL print.

Network:

Displays the current network settings. You can also print the status sheet.

## Authentication Device Status

Select the menus on the control panel as described below.

**Settings > Authentication Device Status**

Displays the status of the authentication device.

## Epson Open Platform Information

Select the menus on the control panel as described below.

**Settings > Epson Open Platform Information**

Displays the status of the Epson Open Platform.

---

# Product Specifications

## Printing Features

Printing Method	Laser beam scanning and dry electrophotographic process	
Resolution	600×600 dpi, 1200×1200dpi	
Continuous Printing Speed on A4 Size Paper* <sup>1</sup>	AL-M8250DN	45 PPM
	AL-M8150DN	40 PPM
	AL-M7150DN	35 PPM
Time for Printing A4 Size Paper	AL-M8250DN	From ready mode in monochrome: 6.3 s From sleep mode in monochrome: 23 s
	AL-M8150DN	From ready mode in monochrome: 6.3 s From sleep mode in monochrome: 26 s
	AL-M7150DN	From ready mode in monochrome: 6.3 s From sleep mode in monochrome: 24 s

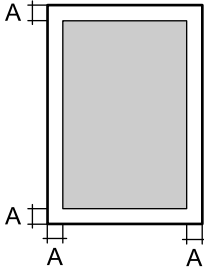
Warm Up Time	AL-M8250DN	110 V from power off: Less than 20 s 110 V from sleep mode: Less than 21 s
	AL-M8150DN	110 V from power off: Less than 18 s 110 V from sleep mode: Less than 19 s
	AL-M7150DN	110 V from power off: Less than 15 s 110 V from sleep mode: Less than 16 s
Automatic 2-sided Printing Function	Supported	
Printer Language	ESC/PageS Printing system, ESC/Page PCL6/PCL5 emulation (PCL mode) PostScript compatible with PostScript Level 3 (PS mode) PDF 1.7	
Resident Fonts	16 scalable fonts for ESC/Page 95 scalable fonts for PCL5 80 scalable fonts for PCL6 80 scalable fonts for PostScript3 compatible with PostScript Level 3	
Bitmap Fonts	7 bitmap fonts for ESC/Page 5 bitmap for PCL5 1 bitmap for PCL6	
Memory (RAM)	2GB	
Supported Protocols	TCP/IPv4, TCP/IPv6 LPD, IPP, PORT9100, WSD SNMP, HTTP, DHCP, BOOTP, APIPA, PING, DDNS, mDNS, SNTP, SLP, WSD, LLTD	
Printable Area *2	<p>The assured printable area is an area 4 mm from all sides.</p>  <p>A: 4 mm</p>	

\*1: Depending on the paper type or size, such as printing on paper smaller than A4, the print speed may become slower. The abbreviation "ppm" means "pages per minute".

\*2: The printable area may be smaller depending on the application.

## Using Port for the Printer

The printer uses the following port. These ports should be allowed to become available by the network administrator as necessary.

### When the Sender (Client) is the Printer

Use	Destination (Server)	Protocol	Port Number
Email sending (When email notification is used from the printer)	SMTP server	SMTP (TCP)	25
		SMTP SSL/TLS (TCP)	465
		SMTP STARTTLS (TCP)	587
POP before SMTP connection (When email notification is used from the printer)	POP server	POP3 (TCP)	110
When Epson Connect is used	Epson Connect Server	HTTPS	443
		XMPP	5222
Control WSD	Client computer	WSD (TCP)	5357

### When the Sender (Client) is the Client Computer

Use	Destination (Server)	Protocol	Port Number
File Sending (When FTP printing is used from the printer)	Printer	FTP (TCP)	20
			21
Discover the printer from an application such as EpsonNet Config, printer driver.	Printer	ENPC (UDP)	3289
Collect and set up the MIB information from an application such as EpsonNet Config, printer driver.	Printer	SNMP (UDP)	161
Forwarding LPR data	Printer	LPR (TCP)	515
Forwarding RAW data	Printer	RAW (Port9100) (TCP)	9100
Forwarding AirPrint (IPP/IPPS printing) data	Printer	IPP/IPPS (TCP)	631
Searching WSD printer	Printer	WS-Discovery (UDP)	3702
Web Config	Printer	HTTP(TCP)	80
		HTTPS(TCP)	443

## Interface Specifications

For Computer	SuperSpeed USB
--------------	----------------

## Network Specifications

### Ethernet Specifications

Standards	IEEE802.3i (10BASE-T)* <sup>1</sup> IEEE802.3u (100BASE-TX) IEEE802.3ab (1000BASE-T)* <sup>1</sup> IEEE802.3az (Energy Efficient Ethernet)* <sup>2</sup>
Communication Mode	Auto, 10 Mbps Full duplex, 10 Mbps Half duplex, 100 Mbps Full duplex, 100 Mbps Half duplex
Connector	RJ-45

\*1 Use a category 5e or higher STP (Shielded twisted pair) cable to prevent risk of radio interference.

\*2 The connected device should comply with IEEE802.3az standards.

### Network Functions and IPv4/IPv6

Functions			Supported	Remarks
Network Printing	EpsonNet Print (Windows)	IPv4	✓	-
	Standard TCP/IP (Windows)	IPv4, IPv6	✓	-
	WSD Printing (Windows)	IPv4, IPv6	✓	Windows Vista or later
	BonjourPrinting (Mac OS)	IPv4, IPv6	✓	-
	IPPPrinting (Windows, Mac OS)	IPv4, IPv6	✓	-
	PictBridgePrinting (Wi-Fi)	IPv4	-	Digital camera
	Epson Connect (Email Print, Remote Print)	IPv4	✓	-
	AirPrint (iOS, Mac OS)	IPv4, IPv6	✓	iOS 5 or later, Mac OS X v10.7 or later
Network Scanning	Epson Scan 2	IPv4, IPv6	-	-
	Event Manager	IPv4	-	-
	Epson Connect (Scan to Cloud)	IPv4	-	-
	AirPrint (Scan)	IPv4, IPv6	-	-
Fax	Send a fax	IPv4	-	-
	Receive a fax	IPv4	-	-
	AirPrint (Faxout)	IPv4, IPv6	-	-

## Security Protocol

IEEE802.1X*	
IPsec/IP Filtering	
SSL/TLS	HTTPS Server/Client
	IPPS
SMTPS (STARTTLS, SSL/TLS)	
SNMPv3	

\* You need to use a device for connection that complies with IEEE802.1X.

## Supported Third Party Services

AirPrint	iOS 5 or later/Mac OS X v10.7.x or later
----------	--

## PostScript Level 3 Compatibility

The PostScript used on this printer is compatible with PostScript Level 3.

## Dimensions

Dimensions* <sup>1</sup>	<input type="checkbox"/> Width: 490 mm (19.3 in.) <input type="checkbox"/> Depth* <sup>2</sup> : 410 mm (16.2 in.) <input type="checkbox"/> Height: 335 mm (13.2 in.)
Weight* <sup>3</sup>	Approx. 21 kg (46.3 lb)

\*1: With the paper tray closed and without any protruding sections.

\*2: 420 mm including the paper size setting dial.

\*3: With consumable products.

## Electrical Specifications

AL-M8250DN

Power Supply Rating	AC 110 V
Rated Frequency Range	60 Hz
Rated Current	12.8 A

Power Consumption (without USB Connection)	Printing in monochrome: Approx. 672 W Ready mode (Fuser Temperature-Keep)*1: Approx. 54 W Ready mode (Fuser Temperature-Don't Keep)*2: Approx. 6.3 W Sleep mode*3: Approx. 4.0 W Power off: Approx. 3.4 W Maximum Power Consumption: Approx. 1290 W
--	--

AL-M8150DN

Power Supply Rating	AC 220-240 V
Rated Frequency Range	50/60 Hz
Rated Current	6.0 A
Power Consumption (without USB Connection)	Printing in monochrome: Approx. 660 W Ready mode (Fuser Temperature-Keep)*1: Approx. 54 W Ready mode (Fuser Temperature-Don't Keep)*2: Approx. 3.2 W Sleep mode*3: Approx. 0.51 W Power off: Approx. 0.07 W Maximum Power Consumption: Approx. 1230 W

AL-M7150DN

Power Supply Rating	AC 110 V
Rated Frequency Range	60 Hz
Rated Current	12.8 A
Power Consumption (without USB Connection)	Printing in monochrome: Approx. 575 W Ready mode (Fuser Temperature-Keep)*1: Approx. 55 W Ready mode (Fuser Temperature-Don't Keep)*2: Approx. 6.3 W Sleep mode*3: Approx. 4.0 W Power off: Approx. 3.4 W Maximum Power Consumption: Approx. 1280 W

\*1: When **Quick Sleep** is set to Off and **Fuser Temperature > Keep** is selected.

\*2: When **Quick Sleep** is set to On, the printer is connected to a network, and after printing has been performed.

\*3: There are various states of sleep mode. It is necessary to meet a variety of conditions to achieve the stated power consumption.

- There is no print data in sleep mode.
- Network settings such as Wi-Fi and Epson Connect are disabled.
- Optional items such as the Ethernet Board is disconnected.

The stated power consumption may not be achieved depending on your network environment.



## Environmental Specifications

Operation	<p>Temperature: 10 to 32°C (50 to 90°F)</p> <p>Humidity: 15 to 85% RH (without condensation)</p> <p>Altitude (Air pressure)*: 0 to 2500 meters</p>
Storage	<p>Temperature: 0 to 35°C (32 to 95°F)</p> <p>Humidity: 15 to 80% RH (without condensation)</p> <p>Altitude (Air pressure)*: 0 to 2500 meters (0 to 15000 meters in transport)</p>

\*: For high altitude locations, the printer's Highland setting in the Printer Adjust Menu must be adjusted according to the altitude at which the printer is located. See "Printer Adjust Menu" for details.

### Related Information

➔ ["Printer Adjust Menu" on page 201](#)

## System Requirements

### Windows

Windows Vista, Windows 7, Windows 8/8.1, Windows 10 or later (32-bit, 64-bit)

Windows XP SP3 (32-bit)

Windows XP Professional x64 Edition SP2

Windows Server 2003 (SP2) or later

### Mac OS

Mac OS X v10.6.8 or later

### **Note:**

*Mac OS may not support some applications and features.*

*The UNIX File System (UFS) for Mac OS is not supported.*

## Printer Adjust Menu

You can make special settings on the printer's control panel. Normally you do not need to change the settings.

The settings in this menu may affect the remaining service lives of consumable products or maintenance.

Select the menus on the control panel as described below.

**Settings > General Settings > System Administration > Printer Adjust Menu**

Paper Type Adjust:

Plain paper

Adjusts the print quality for plain paper according to the paper type.

1: Plain paper1

2: Plain paper2 (default)

## Special

Adjusts the print quality for special paper according to the paper type.

- 1: Plain paper1
- 2: Plain paper2 (default)
- 5: Plain paper3
- 6: Thin paper
- 7: Thick paper1
- 8: Thick paper2
- 9: Thick paper3
- 10: Plain paper3 (Improve thin lines)
- 11: Thick paper (Improve fixing)

## Printer Offset:

### Feed Offset

Adjusts the start position for printing in the vertical direction. You need to adjust Feed Reg1 from Each Tray Offset before making this adjustment. The start position shifts down as the value increases. This setting is available for single-sided printing and for the back of duplex printing.

-3.5 to 3.5 mm (0.0 mm default)

### Scan Offset

Adjusts the start position for printing in the horizontal direction. You need to adjust Scan Reg1 from Each Tray Offset before this adjustment. The start position shifts to the right as the value increases. This setting is available for single-sided printing and for the back of duplex printing.

-3.5 to 3.5 mm (0.0 mm default)

### Feed Offset Back

Adjusts the start position for printing in the vertical direction. You need to adjust Feed Reg2 from Each Tray Offset before making this adjustment. The start position shifts down as the value increases. This setting is available for the front of duplex printing.

-3.5 to 3.5 mm (0.0 mm default)

### Scan Offset Back

Adjusts the start position for printing in the horizontal direction. You need to adjust Scan Reg2 from Each Tray Offset before this adjustment. The start position shifts to the right as the value increases. This setting is available for the front of duplex printing.

-3.5 to 3.5 mm (0.0 mm default)

## Each Tray Offset:

Adjusts the start position for printing for each paper source.

### Feed Reg1

Adjusts the start position for printing in the vertical direction. The start position shifts down as the value increases. This setting is available for single-sided printing and for the back of duplex printing.

-3.5 to 3.5 mm (0.0 mm default)

#### Scan Reg1

Adjusts the start position for printing in the horizontal direction. The start position shifts to the right as the value increases. This setting is available for single-sided printing and for the back of duplex printing.

-3.5 to 3.5 mm (0.0 mm default)

#### Feed Reg2

Adjusts the start position for printing in the vertical direction. The start position shifts down as the value increases. This setting is available for the front of duplex printing.

-3.5 to 3.5 mm (0.0 mm default)

#### Scan Reg2

Adjusts the start position for printing in the horizontal direction. The start position shifts to the right as the value increases. This setting is available for the front of duplex printing.

-3.5 to 3.5 mm (0.0 mm default)

#### Highland:

Adjusts the print quality when using the printer at high altitudes. Increasing the value makes the printer more suitable for high altitudes.

0 to 3 (0 default)

#### Charging Roller Voltage:

Adjusts the print density by correcting for the voltage of the charging roller. The printout becomes lighter as the value increases.

1 (dense) to 5 (light) (3 default)

#### Drum Refresh:

Refreshes the drum. This may help to reduce smears on the print outs. Note that before refreshing the drum, make sure no paper is loaded in the paper tray.

#### Drum Refresh with paper:

This may help to reduce smears on the print outs. Select this menu if Drum Refresh does not reduce smears on the print outs sufficiently. Make sure you load A4 or A3 size plain paper in the paper tray.

#### Automatic Drum Refresh Length:

Specifies the length of time at which the printer refreshes the drum automatically.

(4 min default)

#### Drum Refresh Counter:

Displays the number of times that Drum Refresh has been done.

#### Drum Heater:

Controls the drum heater. Selecting **On** prevents image quality from degrading while the printer is not used for a long time if it is located in a very humid environment. This increases power consumptions, but inhibits the printer's automatic drum refreshes. Drum heater control is enabled as long as power is being supplied.

(Off default for 220 - 240 V models)

(On default for 110 V models)

**Forced Stirring Toner:**

Mixes toner in the developer to spread it evenly.

**Fuser Temperature:**

Saves power by not adjusting the temperature of the fuser while in ready mode. Selecting **Keep** increases the power consumption but shortens the time until printing starts from the ready mode. If **Quick Sleep** is set to **On**, the temperature will not be adjusted after printing even if it is set to **Keep**.

(Don't Keep default)

**Fuser Control:**

Select Reduce Flicker if the fluorescent light flickers when printing.

(Normal default)

**Noise Level:**

Adjusts the image gradation. Image gradation gets better as the value increases, but image granularity gets worse.

0 to 7 (3 default)

**Print Pattern:**

Prints a halftone or full pattern that allows you to check for unevenness in the density or pitch on the printout.

**Screen 25**

Prints the pattern in a 25% density halftone.

**Screen 50**

Prints the pattern in a 50% density halftone.

**Screen 100**

Prints the pattern at 100% density.

---

## Font Specifications

The following fonts are available on the Internet.

- Epson Barcode Font

## Available Fonts for PostScript

Font Name	Family	HP Equivalent
Nimbus Mono	Medium, Bold, Italic, Bold Italic	Courier

<b>Font Name</b>	<b>Family</b>	<b>HP Equivalent</b>
Letter Gothic	Medium, Bold, Italic	Letter Gothic
Nimbus Mono PS	Regular, Bold, Oblique, Bold Oblique	CourierPS
Nimbus Roman No4	Medium, Bold, Italic, Bold Italic	CG Times
URW Classico	Medium, Bold, Italic, Bold Italic	CG Omega
URW Coronet	-	Coronet
URW Clarendon Condensed	-	Clarendon Condensed
URW Classic Sans	Medium, Bold, Italic, Bold Italic	Univers
URW Classic Sans Condensed	Medium, Bold, Italic, Bold Italic	Univers Condensed
Antique Olive	Medium, Bold, Italic	Antique Olive
Garamond	Antiqua, Halbfett, Kursiv, Kursiv Halbfett	Garamond
Mauritius	-	Marigold
Algiers	Medium, Extra Bold	Albertus
NimbusSansNo2	Medium, Bold, Italic, Bold Italic	Arial
Nimbus Roman No9	Medium, Bold, Italic, Bold Italic	Times New Roman
Nimbus Sans	Medium, Bold, Oblique, Bold Oblique	Helvetica
Nimbus Sans Narrow	Medium, Bold, Oblique, Bold Oblique	Helvetica Narrow
Palladio	Roman, Bold, Italic, Bold Italic	Palatino
URW Gothic	Book, Demi, Book Oblique, Demi Oblique	ITC Avant Garde
URW Bookman	Light, Demi, Light Italic, Demi Italic	ITC Bookman
URW Century Schoolbook	Roman, Bold, Italic, Bold Italic	New Century Schoolbook
Nimbus Roman	Medium, Bold, Italic, Bold Italic	Times
URW Chancery Medium Italic	-	ITC Zapf Chancery Italic
Symbol	-	Symbol
URW Dingbats	-	Wingdings
Dingbats	-	ITC Zapf Dingbats
Standard Symbol	-	SymbolIPS

## Available Fonts for PCL (URW)

### Scalable Font

Font Name	Family	HP Equivalent	Symbol Set for PCL5
Nimbus Mono	Medium, Bold, Italic, Bold Italic	Courier	1
Letter Gothic	Medium, Bold, Italic	Letter Gothic	1
Nimbus Mono PS	Regular, Bold, Oblique, Bold Oblique	CourierPS	3
Nimbus Roman No4	Medium, Bold, Italic, Bold Italic	CG Times	2
URW Classico	Medium, Bold, Italic, Bold Italic	CG Omega	3
URW Coronet	-	Coronet	3
URW Clarendon Condensed	-	Clarendon Condensed	3
URW Classic Sans	Medium, Bold, Italic, Bold Italic	Univers	2
URW Classic Sans Condensed	Medium, Bold, Italic, Bold Italic	Univers Condensed	3
Antique Olive	Medium, Bold, Italic	Antique Olive	3
Garamond	Antiqua, Halbfett, Kursiv, Kursiv Halbfett	Garamond	3
Mauritius	-	Marigold	3
Algiers	Medium, Extra Bold	Albertus	3
NimbusSansNo2	Medium, Bold, Italic, Bold Italic	Arial	3
Nimbus Roman No9	Medium, Bold, Italic, Bold Italic	Times New	3
Nimbus Sans	Medium, Bold, Oblique, Bold Oblique	Helvetica	3
Nimbus Sans Narrow	Medium, Bold, Oblique, Bold Oblique	Helvetica Narrow	3
Palladio	Roman, Bold, Italic, Bold Italic	Palatino	3
URW Gothic	Book, Demi, Book Oblique, Demi Oblique	ITC Avant Garde Gothic	3
URW Bookman	Light, Demi, Light Italic, Demi Italic	ITC Bookman	3
URW Century Schoolbook	Roman, Bold, Italic, Bold Italic	New Century Schoolbook	3
Nimbus Roman	Medium, Bold, Italic, Bold Italic	Times	3
URW Chancery Medium Italic	-	ITC Zapf Chancery Medium Italic	3
Symbol	-	Symbol	4
URW Dingbats	-	Wingdings	5
Dingbats	-	ITC Zapf Dingbats	6
Standard Symbol	-	SymbolPS	4

Font Name	Family	HP Equivalent	Symbol Set for PCL5
URW David	Medium, Bold	HP David	7
URW Narkis	Medium, Bold	HP Narkis	7
URW Miryam	Medium, Bold, Italic	HP Miryam	7
URW Koufi	Medium, Bold	Koufi	8
URW Naskh	Medium, Bold	Naskh	8
URW Ryadh	Medium, Bold	Ryadh	8

### Bitmap Font

Font Name	Symbol Set
Line Printer	9

### OCR/Barcode Bitmap Font (for PCL5 only)

Font Name	Family	Symbol Set
OCR A	-	10
OCR B	-	11
Code39	9.37cpi, 4.68cpi	12
EAN/UPC	Medium, Bold	13

**Note:**

Depending on the print density, or on the quality or color of the paper, OCR A, OCR B, Code39, and EAN/UPC fonts may not be readable. Print a sample and make sure the fonts can be read before printing large quantities.

## List of Symbol Sets

Your printer can access a variety of symbol sets. Many of these symbol sets differ only in the international characters specific to each language.

When you are considering which font to use, you should also consider which symbol set to combine with the font.

**Note:**

Since most software handles fonts and symbols automatically, you will probably never need to adjust the printer's settings. However, if you are writing your own printer control programs, or if you are using older software that cannot control fonts, refer to the following sections for symbol set details.

## List of Symbol Sets for PCL 5

Symbol Set Name	Attribute	Font Classification												
		1	2	3	4	5	6	7	8	9	10	11	12	13
Norweg1	0D	✓	✓	✓	-	-	-	-	-	-	-	-	-	-
Roman Extension	0E	-	-	-	-	-	-	-	-	✓	-	-	-	-
Italian	0I	✓	✓	✓	-	-	-	-	-	-	-	-	-	-
ECM94-1	0N	✓	✓	✓	-	-	-	-	-	✓	-	-	-	-
Swedis2	0S	✓	✓	✓	-	-	-	-	-	-	-	-	-	-
ANSI ASCII	0U	✓	✓	✓	-	-	-	✓	✓	-	-	-	-	-
UK	1E	✓	✓	✓	-	-	-	-	-	-	-	-	-	-
French2	1F	✓	✓	✓	-	-	-	-	-	-	-	-	-	-
German	1G	✓	✓	✓	-	-	-	-	-	-	-	-	-	-
Legal	1U	✓	✓	✓	-	-	-	-	-	✓	-	-	-	-
8859-2 ISO	2N	✓	✓	✓	-	-	-	-	-	✓	-	-	-	-
Spanish	2S	✓	✓	✓	-	-	-	-	-	-	-	-	-	-
ISO 8859/4 Latin 4	4N	✓	✓	✓	-	-	-	-	-	-	-	-	-	-
Roman-9	4U	✓	✓	✓	-	-	-	-	-	-	-	-	-	-
PsMath	5M	✓	✓	✓	-	-	-	✓	✓	-	-	-	-	-
8859-9 ISO	5N	✓	✓	✓	-	-	-	-	-	✓	-	-	-	-
WiTurkish	5T	✓	✓	✓	-	-	-	-	-	-	-	-	-	-
MsPublishin	6J	✓	✓	✓	-	-	-	-	-	-	-	-	-	-
VeMath	6M	✓	✓	✓	-	-	-	-	-	-	-	-	-	-
8859-10ISO	6N	✓	✓	✓	-	-	-	-	-	✓	-	-	-	-
DeskTop	7J	✓	✓	✓	-	-	-	-	-	-	-	-	-	-
Math-8	8M	✓	✓	✓	-	-	-	✓	✓	-	-	-	-	-
Roman-8	8U	✓	✓	✓	-	-	-	-	-	✓	-	-	-	-
WiE.Europe	9E	✓	✓	✓	-	-	-	-	-	-	-	-	-	-
Pc1004	9J	✓	✓	✓	-	-	-	-	-	-	-	-	-	-
8859-15ISO	9N	✓	✓	✓	-	-	-	-	-	✓	-	-	-	-
PcTk437	9T	✓	✓	✓	-	-	-	-	-	-	-	-	-	-
Windows	9U	✓	✓	✓	-	-	-	-	-	-	-	-	-	-



Symbol Set Name	Attribute	Font Classification												
		1	2	3	4	5	6	7	8	9	10	11	12	13
PsText	10J	✓	✓	✓	-	-	-	-	-	-	-	-	-	-
IBM-US	10U	✓	✓	✓	-	-	-	-	-	✓	-	-	-	-
IBM-DN	11U	✓	✓	✓	-	-	-	-	-	✓	-	-	-	-
McText	12J	✓	✓	✓	-	-	-	-	-	-	-	-	-	-
PcMultiling	12U	✓	✓	✓	-	-	-	-	-	✓	-	-	-	-
VeInternati	13J	✓	✓	✓	-	-	-	-	-	-	-	-	-	-
PcEur858	13U	✓	✓	✓	-	-	-	-	-	-	-	-	-	-
VeUS	14J	✓	✓	✓	-	-	-	-	-	-	-	-	-	-
PiFont	15U	✓	✓	✓	-	-	-	-	-	-	-	-	-	-
PcE.Europe	17U	✓	✓	✓	-	-	-	-	-	-	-	-	-	-
Unicode 3.0	18N	✓	✓	✓	-	-	-	✓	✓	-	-	-	-	-
WiBALT	19L	✓	✓	✓	-	-	-	-	-	-	-	-	-	-
WiAnsi	19U	✓	✓	✓	-	-	-	-	-	-	-	-	-	-
PcBlit775	26U	✓	✓	✓	-	-	-	-	-	-	-	-	-	-
Pc866Cyr	3R	✓	✓	-	-	-	-	-	-	-	-	-	-	-
Greek8	8G	✓	✓	-	-	-	-	-	-	-	-	-	-	-
WinGrk	9G	✓	✓	-	-	-	-	-	-	-	-	-	-	-
WinCyr	9R	✓	✓	-	-	-	-	-	-	-	-	-	-	-
Pc851Grk	10G	✓	✓	-	-	-	-	-	-	-	-	-	-	-
ISOCyr	10N	✓	✓	-	-	-	-	-	-	✓	-	-	-	-
Pc8Grk	12G	✓	✓	-	-	-	-	-	-	-	-	-	-	-
ISOGrk	12N	✓	✓	-	-	-	-	-	-	-	-	-	-	-
Pc866Ukr	14R	✓	✓	-	-	-	-	-	-	-	-	-	-	-
Hebrew7	0H	✓	-	-	-	-	-	✓	-	-	-	-	-	-
8859-8 ISO	7H	✓	-	-	-	-	-	✓	-	-	-	-	-	-
Hebrew8	8H	✓	-	-	-	-	-	✓	-	-	-	-	-	-
Pc862Heb	15H	✓	-	-	-	-	-	✓	-	-	-	-	-	-
PC-862, Hebrew	15Q	✓	-	-	-	-	-	✓	-	-	-	-	-	-
Arabic8	8V	-	-	-	-	-	-	-	✓	-	-	-	-	-
HPWARA	9V	-	-	-	-	-	-	-	✓	-	-	-	-	-

Symbol Set Name	Attribute	Font Classification												
		1	2	3	4	5	6	7	8	9	10	11	12	13
Pc864Ara	10V	-	-	-	-	-	-	-	✓	-	-	-	-	-
Symbol	19M	-	-	-	✓	-	-	-	-	-	-	-	-	-
Wingdings	579L	-	-	-	-	✓	-	-	-	-	-	-	-	-
ZapfDigrbats	14L	-	-	-	-	-	✓	-	-	-	-	-	-	-
OCR A	00	-	-	-	-	-	-	-	-	-	✓	-	-	-
OCR B	10	-	-	-	-	-	-	-	-	-	-	✓	-	-
OCR B Extension	3Q	-	-	-	-	-	-	-	-	-	-	✓	-	-
Code3-9	0Y	-	-	-	-	-	-	-	-	-	-	-	✓	-
EAN/UPC	8Y	-	-	-	-	-	-	-	-	-	-	-	-	✓

## Epson BarCode Fonts (Windows Only)

Epson BarCode Fonts let you easily create and print many types of bar codes.

Normally, bar code creation is a laborious process requiring you to specify various command codes, such as Start bar, Stop bar and OCR-B, in addition to the bar code characters themselves. However, Epson BarCode Fonts are designed to add such codes automatically, allowing you to easily print bar codes that conform to a variety of bar code standards.

### Printing with Epson BarCode Fonts

Follow the steps below to create and print bar codes using Epson BarCode Fonts. The application featured in these instructions is Microsoft WordPad in Windows 10. The actual procedure may differ slightly when printing from other applications.

1. Open a document in your application and enter the characters you want to convert into a bar code.



2. Select the characters, then select the Epson BarCode font you want to use, and the font size.

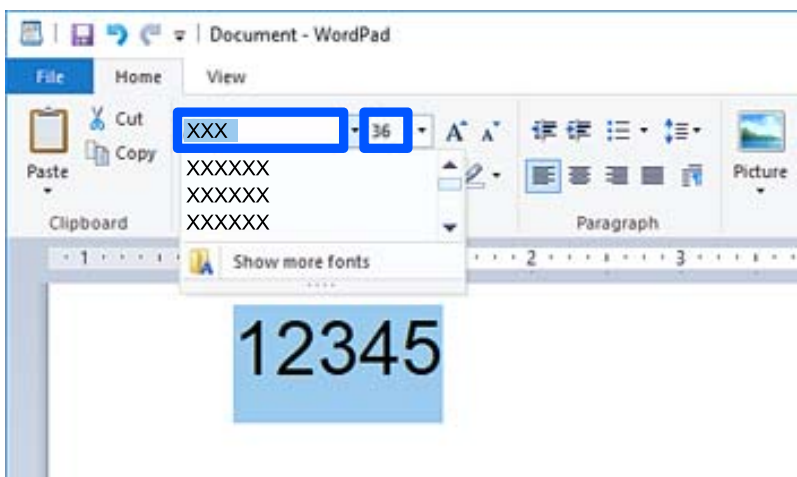

**Note:**

*You cannot use font sizes larger than 96 points when printing bar codes.*

- The characters you selected appear as bar code characters similar to those shown below.

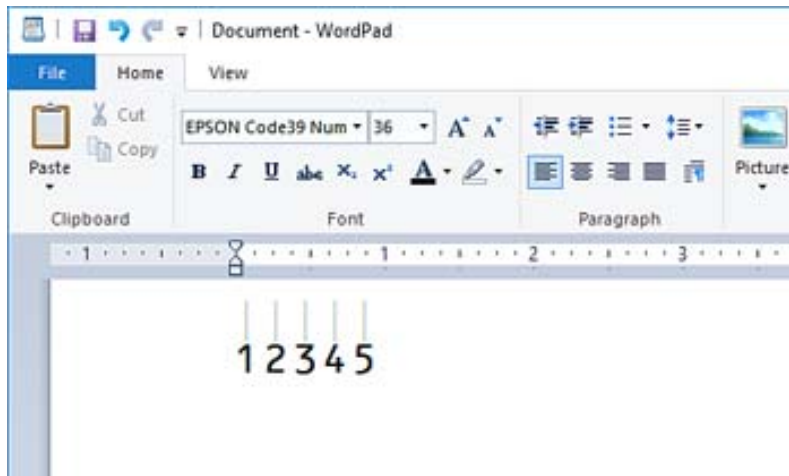

- Select **Print** from the File menu, select your Epson printer, click **Preferences**, and then make the printer driver settings.
- Click **Print** to print the bar code.

**Note:**

*If there is an error in the bar code character string, such as inappropriate data, the bar code will be printed as it appears on the screen, but it cannot be read by a bar code reader.*

## Notes on inputting and formatting bar codes

Please note the following when inputting and formatting bar code characters:

- Do not apply shading or special character formatting, such as bold, italic, or underline.
- Print bar codes in black and white only.
- When rotating characters, only specify rotation angles of 90°, 180°, and 270°.
- Turn off all automatic character and word spacing settings in your application.
- Do not use features in your application that enlarge or reduce the size of characters in only the vertical or horizontal direction.
- Turn off your application's auto-correct features for spelling, grammar, spacing, etc.
- To more easily distinguish bar codes from other text in your document, set your application to show text symbols, such as paragraph marks, tabs, etc.
- Because special characters such as Start bar and Stop bar are added when an Epson BarCode Font is selected, the resulting bar code may have more characters than were originally input.
- For best results, use only the font sizes recommended in "Epson BarCode Font Specifications" for the Epson BarCode Font you are using. Bar codes in other sizes may not be readable with all bar code readers.
- Select **Grayscale** in the **Print Settings** and **High** in the **Quality**.

**Note:**

*Depending on the print density, or on the quality or color of the paper, bar codes may not be readable with all bar code readers. Print a sample and make sure the bar code can be read before printing large quantities.*

## Epson BarCode Fonts specifications

This section contains details on the character input specifications for each Epson BarCode Font.

### EPSON EAN-8

- EAN-8 is an eight-digit abbreviated version of the EAN bar code standard.
- Because the check digit is added automatically, only 7 characters can be input.

Character type	Numbers (0 to 9)
Number of characters	7 characters
Font size	52 pt to 96 pt. Recommended sizes are 52 pt and 65 pt (standard).

The following codes are inserted automatically and need not be input by hand:

- Left/Right margin
- Left/Right guard bar
- Center bar
- Check digit
- OCR-B

Print sample

EPSON EAN-8

### EPSON EAN-13

- EAN-13 is the standard 13-digit EAN bar code.
- Because the check digit is added automatically, only 12 characters can be input.

Character type	Numbers (0 to 9)
Number of characters	12 characters
Font size	60 pt to 96 pt. Recommended sizes are 60 pt and 75 pt (standard).

The following codes are inserted automatically and need not be input by hand:

- Left/Right margin
- Left/Right guard bar
- Center bar

Check digit

OCR-B

Print sample



## EPSON UPC-A

UPC-A is the standard bar code specified by the American Universal Product Code (UPC Symbol Specification Manual).

Only regular UPC codes are supported. Supplementary codes are not supported.

Character type	Numbers (0 to 9)
Number of characters	11 characters
Font size	60 pt to 96 pt. Recommended sizes are 60 pt and 75 pt (standard).

The following codes are inserted automatically and need not be input by hand:

Left/Right margin

Left/Right guard bar

Center bar

Check digit

OCR-B

Print sample



## EPSON UPC-E

UPC-E is the UPC-A zero-suppression (deletes extra zeros) bar code specified by the American Universal Product Code (UPC Symbol Specification Manual).

Character type	Numbers (0 to 9)
Number of characters	6 characters

Font size	60 pt to 96 pt. Recommended sizes are 60 pt and 75 pt (standard).
-----------	---

The following codes are inserted automatically and need not be input by hand:

- Left/Right margin
- Left/Right guard bar
- Check digit
- OCR-B
- The numeral “0”

Print sample

EPSON UPC-E

## EPSON Code39

- Four Code39 fonts are available, allowing you to enable and disable the automatic insertion of check digits and OCR-B.
- The height of the bar code is automatically adjusted to 15% or more of its total length, in conformance to the Code39 standard. For this reason, it is important to keep at least one space between the bar code and the surrounding text to prevent overlapping.
- Spaces in Code39 bar codes should be input as “\_” underbars.
- When printing two or more bar codes on one line, separate the bar codes with a tab, or select a font other than a BarCode Font and input the space. If a space is input while a Code39 font is selected, the bar code will not be correct.





Character type	Alphanumeric characters (A to Z, 0 to 9) Symbols (- . space \$ / + %)
Number of characters	No limit
Font size	When OCR-B is not used: 26 pt to 96 pt. Recommended sizes are 26 pt, 52 pt and 78 pt. When OCR-B is used: 36 pt to 96 pt. Recommended sizes are 36 pt and 72 pt.

The following codes are inserted automatically and need not be input by hand:

- Left/Right quiet zone
- Check digit
- Start/Stop character

Print sample

EPSON Code39	EPSON Code39 CD
--------------	-----------------

	
EPSON Code39 Num	EPSON Code39 CD Num
 1 2 3 4 5 6 7	 1 2 3 4 5 6 7 5

## EPSON Code128

- Code128 fonts support code sets A, B, and C. When the code set of a line of characters is changed in the middle of the line, a conversion code is automatically inserted.
- The height of the bar code is automatically adjusted to 15% or more of its total length, in conformance to the Code128 standard. For this reason, it is important to keep at least one space between the bar code and the surrounding text to prevent overlapping.
- Some applications automatically delete the spaces at the end of lines or change multiple spaces into tabs. Bar codes containing spaces may not be correctly printed from applications that automatically delete spaces from the ends of lines or change multiple spaces into tabs.
- When printing two or more bar codes on one line, separate the bar codes with a tab, or select a font other than a BarCode Font and input the space. If a space is input while a Code128 font is selected, the bar code will not be correct.

Character type	All ASCII characters (95 in total)
Number of characters	No limit
Font size	26 pt to 96 pt. Recommended sizes are 26 pt, 52 pt and 78 pt.

The following codes are inserted automatically and need not be input by hand:

- Left/Right quiet zone
- Start/Stop character
- Check digit
- Change code set character

Print sample

EPSON Code128

## EPSON ITF

- The EPSON ITF fonts conform to the USSInterleaved 2-of-5 standard (American).
- Four EPSON ITF fonts are available, allowing you to enable and disable the automatic insertion of check digits and OCR-B.
- The height of the bar code is automatically adjusted to 15% or more of its total length, in conformance to the Interleaved 2-of-5 standard. For this reason, it is important to keep at least one space between the bar code and the surrounding text to prevent overlapping.







- Interleaved 2-of-5 treats every two characters as one set. When there are an odd number of characters, EPSON ITF fonts automatically add a zero to the beginning of the character string.

Character type	Numbers (0 to 9)
Number of characters	No limit
Font size	When OCR-B is not used: 26 pt to 96 pt. Recommended sizes are 26 pt, 52 pt and 78 pt. When OCR-B is used: 36 pt to 96 pt. Recommended sizes are 36 pt and 72 pt.

The following codes are inserted automatically and need not be input by hand:

- Left/Right quiet zone
- Start/Stop character
- Check digit
- The numeral “0” (added to the beginning of character strings as needed)

Print sample

EPSON ITF	EPSON ITF CD
	
EPSON ITF Num	EPSON ITF CD Num
	

## EPSON Codabar

- Four EPSON Codabar are available, allowing you to enable and disable the automatic insertion of check digits and OCR-B.
- The height of the bar code is automatically adjusted to 15% or more of its total length, in conformance to the Codabar standard. For this reason, it is important to keep at least one space between the bar code and the surrounding text to prevent overlapping.
- When either a Start or a Stop character is input, Codabar fonts automatically insert the complementary character.
- If neither a Start nor a Stop character is input, these characters are automatically input as the letter “A”.





Character type	Numbers (0 to 9) Symbols (- \$ : / . +)
Number of characters	No limit
Font size	When OCR-B is not used: 26 pt to 96 pt. Recommended sizes are 26 pt, 52 pt and 78 pt. When OCR-B is used: 36 pt to 96 pt. Recommended sizes are 36 pt and 72 pt.

The following codes are inserted automatically and need not be input by hand:

- Left/Right quiet zone

- Start/Stop character (when not input)
- Check digit

Print sample

EPSON Codabar	EPSON Codabar CD
	
EPSON Codabar Num	EPSON Codabar CD Num
	

## EPSON EAN128

- GS1-128(EAN128) fonts support code sets A, B, and C. When the code set of a line of characters is changed in the middle of the line, a conversion code is automatically inserted.
- The following 4 kinds of the properties are supported as the Application Identifier (AI).
  - 01: Global traded item number
  - 10: Batch / Lot number
  - 17: Expiry date
  - 30: Quantity
- The height of the bar code is automatically adjusted to 15% or more of its total length, in conformance to the Code128 standard. For this reason, it is important to keep at least one space between the bar code and the surrounding text to prevent overlapping.
- Some applications automatically delete the spaces at the end of lines or change multiple spaces into tabs. Bar codes containing spaces may not be correctly printed from applications that automatically delete spaces from the ends of lines or change multiple spaces into tabs.
- When printing two or more bar codes on one line, separate the bar codes with a tab, or select a font other than a BarCode Font and input the space. If a space is input while a GS1-128(EAN128) font is selected, the bar code will not be correct.

Character type	Alphanumeric characters (A to Z, 0 to 9) Parenthesis are only for identification of the Application Identifier (AI) Only the capital letters are supported by the small letter key input.
Number of characters	It changes with the Application Identifier (AI). 01: 4 characters "(01)" and 13 numbers 17: 4 characters "(17)" and 6 numbers 10: 4 characters "(10)" and maximum of 20 alphanumeric characters 30: 4 characters "(30)" and maximum of 8 numbers
Font size	36 pt or more Recommended sizes are 36 pt, 72 pt

The following codes are inserted automatically and need not be input by hand:

Left/Right quiet zone

Start/Stop character

FNC1 character

It inserts for discernment from Code128 and for a pause of the variable length application identifier.

Check digit

Change code set character

Print sample



---

## Regulatory Information

### Standards and Approvals

### Restrictions on Copying

Observe the following restrictions to ensure the responsible and legal use of the printer.

Copying of the following items is prohibited by law:

- Bank bills, coins, government-issued marketable securities, government bond securities, and municipal securities
- Unused postage stamps, pre-stamped postcards, and other official postal items bearing valid postage
- Government-issued revenue stamps, and securities issued according to legal procedure

Exercise caution when copying the following items:

- Private marketable securities (stock certificates, negotiable notes, checks, etc.), monthly passes, concession tickets, etc.
- Passports, driver's licenses, warrants of fitness, road passes, food stamps, tickets, etc.

**Note:**

*Copying these items may also be prohibited by law.*

Responsible use of copyrighted materials:

Printers can be misused by improperly copying copyrighted materials. Unless acting on the advice of a knowledgeable attorney, be responsible and respectful by obtaining the permission of the copyright holder before copying published material.

---

# Administrator Information

Software Information for Administrators. . . . .	221
Connecting the Printer to the Network. . . . .	223
Settings to Use the Printer. . . . .	227
Managing the Printer. . . . .	243
Advanced Security Settings. . . . .	255
Epson Remote Services Information. . . . .	288

## Software Information for Administrators

The following describes the software that configures and manages devices.

### Application for Configuring Printer Operations (Web Config)

Web Config is an application that runs in a web browser, such as Internet Explorer and Safari, on a computer or smart device. You can confirm the printer status or change the network service and printer settings. To use the Web Config, connect the printer and the computer or device to the same network.

When the wireless router is connected to the same network as the printer, you can operate the printer via the wireless router from your smart device.

The following browsers are supported.

Microsoft Edge, Internet Explorer 8 or later, Firefox\*, Chrome\*, Safari\*

\* Use the latest version.

**Note:**

*If the administrator password has not been set when accessing Web Config, the password must be set on the administrator password setting page.*

*Do not forget the user name and the password. If you forget them, you will need to contact Epson service support.*

### Running Web Config on a Web Browser

1. Check the printer's IP address.

Select the network icon on the printer's home screen, and then select the active connection method to confirm the printer's IP address.

To select an item, use the ▲ ▼ ◀ ▶ buttons, and then press the OK button.

**Note:**

*You can also check the IP address by printing the network connection report.*

2. Launch a Web browser from a computer or smart device, and then enter the printer's IP address.

Format:

IPv4: http://the printer's IP address/

IPv6: http://[the printer's IP address]/

Examples:

IPv4: http://192.168.100.201/

IPv6: http://[2001:db8::1000:1]/

**Note:**

*Using the smart device, you can also run Web Config from the maintenance screen of Epson iPrint.*

Since the printer uses a self-signed certificate when accessing HTTPS, a warning is displayed on the browser when you start Web Config; this does not indicate a problem and can be safely ignored.

## Related Information

- ➔ [“Application for Printing Easily from a Smart Device \(Epson iPrint\)” on page 184](#)
- ➔ [“Printing a Network Connection Report” on page 138](#)

## Running Web Config on Windows

When connecting a computer to the printer using WSD, follow the steps below to run Web Config.

1. Open the printer list on the computer.
  - Windows 10  
Click on the start button, and then select **Windows System > Control Panel > View devices and printers in Hardware and Sound**.
  - Windows 8.1/Windows 8  
Select **Desktop > Settings > Control Panel > View devices and printers in Hardware and Sound (or Hardware)**.
  - Windows 7  
Click the start button, and select **Control Panel > View devices and printers in Hardware and Sound**.
  - Windows Vista  
Click the start button, and select **Control Panel > Printers in Hardware and Sound**.
2. Right-click on your printer and select **Properties**.
3. Select the **Web Service** tab and click the URL.

Since the printer uses a self-signed certificate when accessing HTTPS, a warning is displayed on the browser when you start Web Config; this does not indicate a problem and can be safely ignored.

## Running Web Config on Mac OS

1. Select **System Preferences** from the Apple menu > **Printers & Scanners** (or **Print & Scan, Print & Fax**), and then select the printer.
2. Click **Options & Supplies > Show Printer Webpage**.

Since the printer uses a self-signed certificate when accessing HTTPS, a warning is displayed on the browser when you start Web Config; this does not indicate a problem and can be safely ignored.

## Application for Setting up the Device on a Network (EpsonNet Config)

EpsonNet Config is an application that allows you to set the network interface addresses and protocols. See the operations guide for EpsonNet Config or the application's help for more details.

### Starting on Windows

- Windows 10/Windows Server 2019/Windows Server 2016  
Click the start button, and then select **EpsonNet > EpsonNet Config**.
- Windows 8.1/Windows 8/Windows Server 2012 R2/Windows Server 2012  
Enter the application name in the search charm, and then select the displayed icon.
- Windows 7/Windows Vista/Windows XP/Windows Server 2008 R2/Windows Server 2008/Windows Server 2003 R2/Windows Server 2003  
Click the start button, and select **All Programs** or **Programs > EpsonNet > EpsonNet Config SE > EpsonNet Config**.

### Starting on Mac OS

Go > Applications > Epson Software > EpsonNet > EpsonNet Config SE > EpsonNet Config.

### Related Information

➔ [“Installing the Applications Separately” on page 96](#)

## Software for Managing Devices on the Network (Epson Device Admin)

Epson Device Admin is a multifunctional application software that manages the device on the network.

The following functions are available.

- Monitor or manage up to 2,000 printers over the segment
- Make a detailed report, such as for the consumable or product status
- Update the firmware of the product
- Introduce the device to the network
- Apply the unified settings to multiple devices.

You can download Epson Device Admin from Epson support website. For more information, see the documentation or help of Epson Device Admin.

---

## Connecting the Printer to the Network

You can connect the printer to the network in several ways.

- Connect by using advanced settings on the control panel.
- Connect by using the installer on the website or on the software disc.

This section explains the procedure to connect the printer to the network using the printer's control panel.

### Before Making Network Connection

To connect to the network, check the connection method and setting information for connection in advance.

## Gathering Information on the Connection Setting

Prepare the necessary setting information to connect. Check the following information in advance.

Divisions	Items	Note
LAN connection information	<input type="checkbox"/> IP address <input type="checkbox"/> Subnet mask <input type="checkbox"/> Default gateway	Decide the IP address to assign to the printer.  When you assign the IP address statically, all values are required.  When you assign the IP address dynamically using the DHCP function, this information is not required because it is set automatically.
DNS server information	<input type="checkbox"/> IP address for primary DNS <input type="checkbox"/> IP address for secondary DNS	These are required when specifying DNS servers. The secondary DNS is set when the system has a redundant configuration and there is a secondary DNS server.  If you are in a small organization and do not set the DNS server, set the IP address of the router.
Proxy server information	<input type="checkbox"/> Proxy server name	Set this when your network environment uses the proxy server to access the internet from the intranet, and you use the function that the printer directly accesses to the internet.  For the following functions, the printer directly connects to the internet . <ul style="list-style-type: none"> <li><input type="checkbox"/> Epson Connect Services</li> <li><input type="checkbox"/> Cloud services of other companies</li> <li><input type="checkbox"/> Firmware updating</li> </ul>
Port number information	<input type="checkbox"/> Port number to release	Check the port number used by the printer and computer, then release the port that is blocked by a firewall, if necessary.  See the following for the port number used by the printer.  <a href="#">"Using Port for the Printer" on page 197</a>

## IP Address Assignment

These are the following types of IP address assignment.

### Static IP address:

Assign the predetermined IP address to the printer (host) manually.

The information to connect to the network (subnet mask, default gateway, DNS server and so on) need to be set manually.

The IP address does not change even when the device is turned off, so this is useful when you want to manage devices with an environment where you cannot change the IP address or you want to manage devices using the IP address. We recommend settings to the printer, server, etc. that many computers access. Also, when using security features such as IPsec / IP filtering, assign a fixed IP address so that the IP address does not change.

### Automatic assignment by using DHCP function (dynamic IP address):

Assign the IP address automatically to the printer (host) by using the DHCP function of the DHCP server or router.

The information to connect to the network (subnet mask, default gateway, DNS server and so on) is set automatically, so you can easily connect the device to the network.



If the device or the router is turned off, or depending on the DHCP server settings, IP address may change when re-connecting.

We recommend managing devices other than the IP address and communicating with protocols that can follow the IP address.

**Note:**

*When you use the IP address reservation function of the DHCP, you can assign the same IP address to the devices at any time.*

## DNS Server and Proxy Server

The DNS server has a host name, domain name of the email address, etc. in association with the IP address information.

Communication is impossible if the other party is described by host name, domain name, etc. when the computer or the printer performs IP communication.

Queries the DNS server for that information and gets the IP address of the other party. This process is called name resolution.

Therefore, the devices such as computers and printers can communicate using the IP address.

Name resolution is necessary for the printer to communicate using the email function or Internet connection function.

When you use those functions, make the DNS server settings.

When you assign the printer's IP address by using the DHCP function of the DHCP server or router, it is automatically set.

The proxy server is placed at the gateway between the network and the Internet, and it communicates to the computer, printer, and Internet (opposite server) on behalf of each of them. The opposite server communicates only to the proxy server. Therefore, printer information such as the IP address and port number cannot be read and increased security is expected.

When you connect to the Internet via a proxy server, configure the proxy server on the printer.

## Connecting to the Network from the Control Panel

Connect the printer to the network by using the printer's control panel.

### Assigning the IP Address

Set up the basic items such as Host Address, Subnet Mask, Default Gateway.

This section explains the procedure for setting a static IP address.

1. Turn on the printer.
2. Select **Settings** on the home screen on the printer's control panel.
3. Select **General Settings** > **Network Settings** > **Advanced** > **TCP/IP**.

4. Select **Manual** for **Obtain IP Address**.

When you set the IP address automatically by using the DHCP function of router, select **Auto**. In that case, the **IP Address**, **Subnet Mask**, and **Default Gateway** on step 5 to 6 are also set automatically, so go to step 7.

5. Enter the IP address.

Focus moves to the forward segment or the back segment separated by a period if you select ◀ and ▶.

Confirm the value reflected on the previous screen.

6. Set up the **Subnet Mask** and **Default Gateway**.

Confirm the value reflected on the previous screen.



**Important:**

If the combination of the IP Address, Subnet Mask and Default Gateway is incorrect, **Start Setup** is inactive and cannot proceed with the settings. Confirm that there is no error in the entry.

7. Enter the IP address for the primary DNS server.

Confirm the value reflected on the previous screen.

**Note:**

When you select **Auto** for the IP address assignment settings, you can select the DNS server settings from **Manual** or **Auto**. If you cannot obtain the DNS server address automatically, select **Manual** and enter the DNS server address. Then, enter the secondary DNS server address directly. If you select **Auto**, go to step 9.

8. Enter the IP address for the secondary DNS server.

Confirm the value reflected on the previous screen.

9. Select **Start Setup**.

### Setting the Proxy Server

Set up the proxy server if both of the following are true.

- The proxy server is built for Internet connection.
- When using a function in which a printer directly connects to the Internet, such as Epson Connect service or another company's cloud services.

1. Select **Settings** on the home screen.

When making settings after IP address setting, the **Advanced** screen is displayed. Go to step 3.

2. Select **General Settings** > **Network Settings** > **Advanced**.

3. Select **Proxy Server**.

4. Select **Use** for **Proxy Server Settings**.

5. Enter the address for the proxy server by IPv4 or FQDN format.

Confirm the value reflected on the previous screen.

6. Enter the port number for the proxy server.  
Confirm the value reflected on the previous screen.
7. Select **Start Setup**.

## Connecting to Ethernet

Connect the printer to the network by using the Ethernet cable, and check the connection.

1. Connect the printer and hub (LAN switch) by Ethernet cable.
2. Select **Settings** on the home screen.
3. Select **General Settings** > **Network Settings** > **Connection Check**.  
The connection diagnosis result is displayed. Confirm the connection is correct.
4. Select **Dismiss** to finish.  
When you select **Print Check Report**, you can print the diagnosis result. Follow the on-screen instructions to print it.

---

# Settings to Use the Printer

## Using the Print Functions

Enable to use the print function through the network.

To use the printer on the network, you need to set the port for network connection on the computer as well as the printer's network connection.

## Printer Connection Types

The following two methods are available for the printer's network connection.

- Peer to peer connection (direct printing)
- Server / client connection (printer sharing using the Windows server)

### ***Peer to Peer Connection Settings***

This is the connection to connect the printer on the network and the computer directly. Only a network-capable model can be connected.

#### **Connection method:**

Connect the printer to the network directly via hub or access point.

**Printer driver:**

Install the printer driver on each client computer.

When using EpsonNet SetupManager, you can provide the driver's package that includes the printer settings.

**Features:**

- The print job starts immediately because the print job is sent to the printer directly.
- You can print as long as the printer runs.

**Server / Client Connection Settings**

This is the connection that the server computer shares with the printer. To prohibit the connection without going through the server computer, you can enhance the security.

When using USB, the printer without the network function can be also shared.

**Connection method:**

Connect the printer to the network via LAN switch or access point.

You can also connect the printer to the server directly by USB cable.

**Printer driver:**

Install the printer driver on the Windows server depending on the OS of the client computers.

By accessing the Windows server and linking the printer, the printer driver is installed on the client computer and can be used.

**Features:**

- Manage the printer and the printer driver in batch.
- Depending on the server spec, it may take time to start the print job because all print jobs go through the print server.
- You cannot print when the Windows server is turned off.

**Print Settings for Peer to Peer Connection**

For peer to peer connection (direct printing), a printer and a client computer have a one-to-one relationship.

The printer driver must be installed on each client computer.

**Print Settings for Server / Client Connection**

Enable to print from the printer that is connected as the server / client connection.

For the server / client connection, set up the print server first, and then share the printer on the network.

When using the USB cable to connect to the server, also set the print server first, and then share the printer on the network.

### Setting Up the Network Ports

Create the print queue for network printing on the print server by using standard TCP/IP, and then set the network port.

This example is when using Windows 2012 R2.

1. Open the devices and printers screen.  
**Desktop > Settings > Control Panel > Hardware and Sound or Hardware > Devices and Printers.**
2. Add a printer.  
Click **Add printer**, and then select **The printer that I want isn't listed**.
3. Add a local printer.  
Select **Add a local printer or network printer with manual settings**, and then click **Next**.
4. Select **Create a new port**, select **Standard TCP/IP Port** as the Port Type, and then click **Next**.

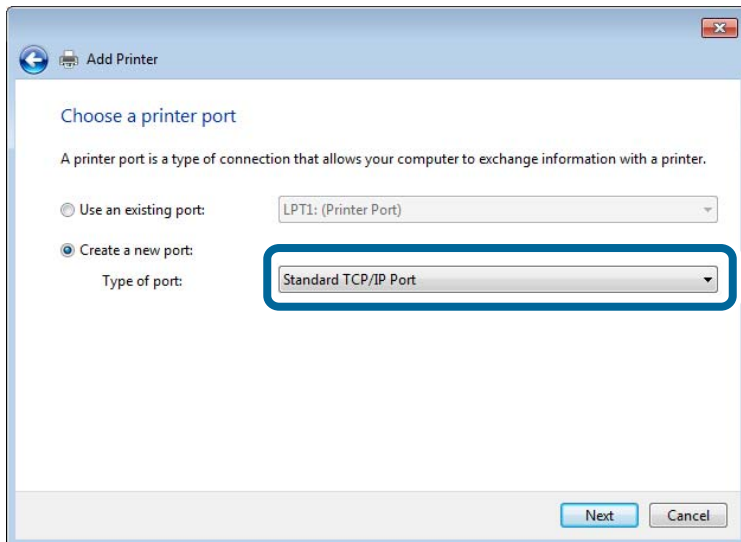

5. Enter the printer's IP address or printer name in **Host Name or IP Address** or **Printer Name or IP Address**, and then click **Next**.

Example:

- Printer name : EPSONA1A2B3C
- IP address : 192.0.2.111

Do not change **Port name**.

Click **Continue** when the **User Account Control** screen is displayed.

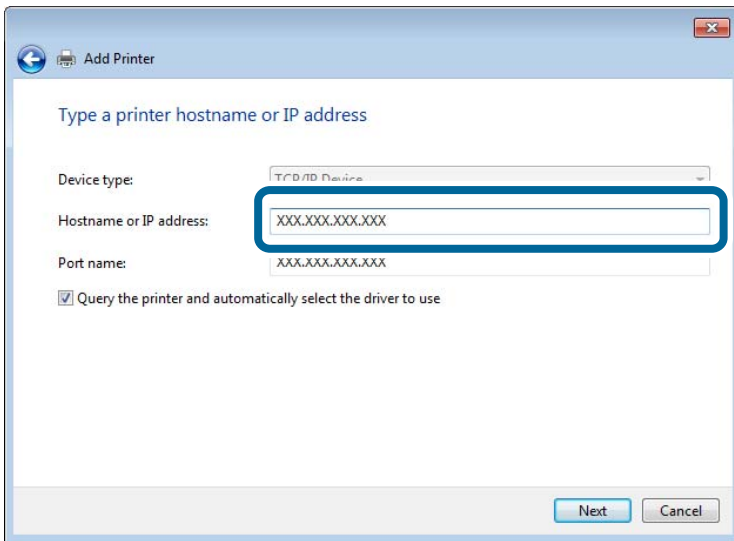

**Note:**

*If you specify the printer name on the network where the name resolution is available, the IP address is tracked even if printer's IP address has been changed by DHCP. You can confirm the printer name from the network status screen on the printer's control panel or network status sheet.*

6. Set the printer driver.
  - If the printer driver is already installed:  
Select **Manufacturer** and **Printers**. Click **Next**.

7. Follow the on-screen instructions.

When using the printer under the server / client connection (printer sharing using the Windows server), make the sharing settings hereafter.

### Checking the Port Configuration - Windows

Check if the correct port is set for the print queue.

1. Open the devices and printers screen.  
**Desktop > Settings > Control Panel > Hardware and Sound** or **Hardware > Devices and Printers**.
2. Open the printer properties screen.  
Right-click the printer icon, and then click **Printer properties**.
3. Click the **Ports** tab, select **Standard TCP/IP Port**, and then click **Configure Port**.
4. Check the port configuration.
  - For RAW  
Check that **Raw** is selected in **Protocol**, and then click **OK**.

For LPR

Check that **LPR** is selected in **Protocol**. Enter "PASSTHRU" in **Queue name** from **LPR Settings**. Select **LPR Byte Counting Enabled**, and then click **OK**.

### ***Sharing the Printer (Windows only)***

When using the printer under the server / client connection (printer sharing using the Windows server), set up the printer sharing from the print server.

1. Select **Control Panel > View devices and printers** on the print server.
2. Right-click the printer icon (print queue) that you want to share with, and then select **Printer Properties > Sharing** tab.
3. Select **Share this printer** and then enter to **Share name**.  
For Windows Server 2012, click **Change Sharing Options** and then configure the settings.

### ***Installing Additional Drivers (Windows only)***

If the Windows versions for a server and clients are different, it is recommended to install additional drivers to the print server.

1. Select **Control Panel > View devices and printers** on the print server.
2. Right-click the printer icon that you want to share with the clients, and then click **Printer Properties > Sharing** tab.
3. Click **Additional Drivers**.  
For Windows Server 2012, click **Change Sharing Options** and then configure the settings.
4. Select versions of Windows for clients, and then click **OK**.
5. Select the information file for the printer driver (\*.inf) and then install the driver.

### ***Using the Shared Printer – Windows***

The administrator needs to inform the clients of the computer name assigned to the print server and how to add it to their computers. If the additional driver(s) have not been configured yet, inform the clients how to use **Devices and Printers** to add the shared printer.

If additional driver(s) have already been configured on the print server, follow these steps:

1. Select the name assigned to the print server in **Windows Explorer**.
2. Double-click the printer that you want to use.

## **Basic Settings for Printing**

Set the print settings, such as paper size or printing error.

### Setting the Paper Source

Set the size and type of paper to be loaded in each paper source.

1. Access Web Config and select the **Print** tab > **Paper Source Settings**.

2. Set each item.

The displayed items may vary by the situation.

- Paper source name

Display the target paper source name, such as **paper tray**, **Cassette 1**.

- Paper Size

Select the paper size you want to set from the pull-down menu.

- Unit

Select the unit of the user-defined size. You can select it when **User defined** is selected on **Paper Size**.

- Width

Set the horizontal length of the user-defined size.

The range you can enter here depends on the paper source, which is indicated on the side of **Width**.

When you select **mm** in **Unit**, you can enter up to one decimal place.

When you select **inch** in **Unit**, you can enter up to two decimal places.

- Height

Set the vertical length of the user-defined size.

The range you can enter here depends on the paper source, which is indicated on the side of **Height**.

When you select **mm** in **Unit**, you can enter up to one decimal place.

When you select **inch** in **Unit**, you can enter up to two decimal places.

- Paper Type

Select the paper type you want to set from the pull-down menu.

3. Check the settings, and then click **OK**.

### Setting the Interface

Set the timeout of the print jobs or printing language assigned to each interface.

This item is displayed on the PCL or PostScript compatible printer.

1. Access Web Config and select the **Print** tab > **Interface Settings**.

2. Set each item.

- Timeout Settings

Set the timeout of the print jobs sent directly via USB.

You can set between 5 and 300 seconds by the second.

When you do not want to timeout, enter 0.

- Printing Language

Select the printing language for each USB interface and network interface.

When you select **Auto**, the printing language is automatically detected by the print jobs being sent.



3. Check the settings, and then click **OK**.

### **Setting Errors**

Set the displaying error for the device.

1. Access Web Config and select the **Print** tab > **Error Settings**.
2. Set each item.
  - Paper Size Notice  
Set whether to display an error on the control panel when the paper size of the specified paper source is different from the paper size of the print data.
  - Paper Type Notice  
Set whether to display an error on the control panel when the paper type of the specified paper source is different from the paper type of the print data.
  - Auto Error Solver  
Set whether to automatically cancel the error if there is no operation on the control panel for 5 seconds after displaying the error.
3. Check the settings, and then click **OK**.

### **Setting Universal Print**

Set when you print from external devices without using the printer driver.

Some items are not displayed depending on the printing language of your printer.

1. Access Web Config and select the **Print** tab > **Universal Print Settings**.
2. Set each item.
3. Check the settings, and then click **OK**.

### **Basic**

<b>Items</b>	<b>Explanation</b>
Top Offset(-30.0-30.0mm)	Sets the vertical position of the paper on which printing starts.
Left Offset(-30.0-30.0mm)	Sets the horizontal position of the paper on which printing starts.
Top Offset in Back(-30.0-30.0mm)	Sets the vertical position of the paper on which the printing of the back side of the paper starts in duplex printing.
Left Offset in Back(-30.0-30.0mm)	Sets the horizontal position of the paper on which the printing of the back side of the paper starts in duplex printing.
Skip Blank Page	If there is a blank page in the print data, set not to print a blank page.

## PDL Print Configuration

You can specify settings for PCL or PostScript printing.

### Common Settings

Items	Explanation
Paper Size	Select the paper size on which you want to print.
Paper Type	Select the type of paper on which you print.
Orientation	Select the orientation you want to use to print.
Quality	Select the print quality you want to use for printing.
Toner Save Mode	Set whether to print with reduced toner consumption.
Print Order	Select to print from the top or the last page.
Number of Copies(1-999)	Set the number of copies you want to print.
Binding Margin	Select the binding position.
Auto Paper Ejection	Select whether to eject paper automatically when timeout is occurred during receiving a print job.
2-Sided Printing	Set whether printing 2-sided.

### PCL Menu

Items	Explanation
Font Source	Select whether to use the font installed on the printer or download it.
Font Number	Specify the font number you want to use.
Pitch(0.44-99.99cpi)	If the font to use is scalable and fixed-pitch font, specify the font size in pitch.
Height(4.00-999.75pt)	If the font to use is scalable and proportional font, specify the font size in points.
Symbol Set	Select the symbol set of the font you want to use.
Form(5-128lines)	Specify the number of lines per page.
CR Function	Select the operation for the CR code (return).
LF Function	Select the operation for the LF code (new line), FF code (new page).
Paper Source Assign	Specify paper feeder assignment for PCL paper feed command.

### PS Menu

Items	Explanation
Error Sheet	Set whether to print an error sheet when PS3 printing error occurs.
Coloration	Set as color printing or monochrome printing. You can only select monochrome for this printer.

Items	Explanation
Binary	Set whether to accept the binary data or not.
PDF Page Size	Set the paper size for PDF printing.

## Setting Up AirPrint

Set when using AirPrint printing.

Access Web Config and select the **Network** tab > **AirPrint Setup**.

Items	Explanation
Bonjour Service Name	Enter the Bonjour service name between 1 and 41 characters in ASCII (0x20-0x7E).
Bonjour Location	Enter location information such as the printer's placement within 127 bytes or less in Unicode (UTF-8).
Geolocation Latitude and Longitude (WGS84)	Enter the printer's location information. This entry is optional. Enter values by using WGS-84 datum, which separates latitude and longitude with a comma. You can enter -90 to +90 for the latitude value, and -180 to +180 for the longitude value. You can enter less than a decimal to the sixth place, and you can omit "+".
Top Priority Protocol	Select top priority protocol from IPP and Port9100.
Wide-Area Bonjour	Set whether or not to use Wide-Area Bonjour. If you use it, the printers must be registered on the DNS server to be able to search the printer over the segment.
Require PIN Code when using IPP printing	Select whether or not to require a PIN code when using IPP printing. If you select <b>Yes</b> , IPP print jobs without PIN codes are not saved in the printer.
Enable AirPrint	IPP, Bonjour, AirPrint are enabled, and IPP is established only with secure communication.

## Configuring a Mail Server

Set the mail server from Web Config.

When the printer can send the email, receiving the email notification from the printer is enabled.

Check below before setting up.

- The printer is connected to the network that can access the mail server.
- Email setting information of the computer that uses the same mail server as the printer.

**Note:**

*When you use the mail server on the Internet, confirm the setting information from the provider or website.*

1. Access Web Config and select the **Network** tab > **Email Server** > **Basic**.
2. Enter a value for each item.

3. Select **OK**.

The settings you have selected are displayed.

When the setup completes, perform the connection check.

## Mail Server Setting Items

Items	Settings and Explanation	
Authentication Method	Specify the authentication method for the printer to access the mail server.	
	Off	Set when the mail server does not need authentication.
	SMTP AUTH	Authenticates on the SMTP server (outgoing mail server) when sending the email. The mail server needs to support SMTP authentication.
	POP before SMTP	Authenticates on the POP3 server (receiving mail server) before sending the email. When you select this item, set the POP3 server.
Authenticated Account	<p>If you select <b>SMTP AUTH</b> or <b>POP before SMTP</b> as the <b>Authentication Method</b>, enter the authenticated account name between 0 and 255 characters in ASCII (0x20-0x7E).</p> <p>When you select <b>SMTP AUTH</b>, enter the SMTP server account. When you select <b>POP before SMTP</b>, enter the POP3 server account.</p>	
Authenticated Password	<p>If you select <b>SMTP AUTH</b> or <b>POP before SMTP</b> as the <b>Authentication Method</b>, enter the authenticated password between 0 and 20 characters in ASCII (0x20-0x7E).</p> <p>When you select <b>SMTP AUTH</b>, enter the authenticated account for the SMTP server. When you select <b>POP before SMTP</b>, enter the authenticated account for the POP3 server.</p>	
Sender's Email Address	<p>Enter the sender's email address such as the email address of the system administrator. This is used when authenticating, so enter a valid email address that is registered to the mail server.</p> <p>Enter between 0 and 255 characters in ASCII (0x20-0x7E) except for : ( ) &lt; &gt; [ ] ; ¥. A period "." cannot be the first character.</p>	
SMTP Server Address	Enter between 0 and 255 characters using A-Z a-z 0-9 . - . You can use IPv4 or FQDN format.	
SMTP Server Port Number	Enter a number between 1 and 65535.	
Secure Connection	Select the encryption method of the communication to the mail server.	
	None	If you select <b>POP before SMTP</b> in <b>Authentication Method</b> , the connection is not encrypted.
	SSL/TLS	This is available when <b>Authentication Method</b> is set to <b>Off</b> or <b>SMTP AUTH</b> . Communication is encrypted from the start.
STARTTLS	This is available when <b>Authentication Method</b> is set to <b>Off</b> or <b>SMTP AUTH</b> . Communication is not encrypted from the start, but depending on the network environment, whether the communication is encrypted or not is changed.	
Certificate Validation	The certificate is validated when this is enabled. We recommend this is set to <b>Enable</b> . To set up, you need to import the CA Certificate to the printer.	

Items	Settings and Explanation
POP3 Server Address	If you select <b>POP before SMTP</b> as the <b>Authentication Method</b> , enter the POP3 server address between 0 and 255 characters using A-Z a-z 0-9 . - . You can use IPv4 or FQDN format.
POP3 Server Port Number	If you select <b>POP before SMTP</b> as the <b>Authentication Method</b> , enter a number between 1 and 65535.

## Checking a Mail Server Connection

You can check the connection to the mail server by performing the connection check.

1. Access Web Config and select the **Network** tab > **Email Server** > **Connection Test**.
2. Select **Start**.

The connection test to the mail server is started. After the test, the check report is displayed.

### Mail Server Connection Test References

Messages	Cause
Connection test was successful.	This message appears when the connection with the server is successful.
SMTP server communication error. Check the following. - Network Settings	This message appears when <ul style="list-style-type: none"> <li><input type="checkbox"/> The printer is not connected to a network</li> <li><input type="checkbox"/> SMTP server is down</li> <li><input type="checkbox"/> Network connection is disconnected while communicating</li> <li><input type="checkbox"/> Received incomplete data</li> </ul>
POP3 server communication error. Check the following. - Network Settings	This message appears when <ul style="list-style-type: none"> <li><input type="checkbox"/> The printer is not connected to a network</li> <li><input type="checkbox"/> POP3 server is down</li> <li><input type="checkbox"/> Network connection is disconnected while communicating</li> <li><input type="checkbox"/> Received incomplete data</li> </ul>
An error occurred while connecting to SMTP server. Check the followings. - SMTP Server Address - DNS Server	This message appears when <ul style="list-style-type: none"> <li><input type="checkbox"/> Connecting to a DNS server failed</li> <li><input type="checkbox"/> Name resolution for an SMTP server failed</li> </ul>
An error occurred while connecting to POP3 server. Check the followings. - POP3 Server Address - DNS Server	This message appears when <ul style="list-style-type: none"> <li><input type="checkbox"/> Connecting to a DNS server failed</li> <li><input type="checkbox"/> Name resolution for an POP3 server failed</li> </ul>
SMTP server authentication error. Check the followings. - Authentication Method - Authenticated Account - Authenticated Password	This message appears when SMTP server authentication failed.

Messages	Cause
POP3 server authentication error. Check the followings. - Authentication Method - Authenticated Account - Authenticated Password	This message appears when POP3 server authentication failed.
Unsupported communication method. Check the followings. - SMTP Server Address - SMTP Server Port Number	This message appears when you try to communicate with unsupported protocols.
Connection to SMTP server failed. Change Secure Connection to None.	This message appears when an SMTP mismatch occurs between a server and a client, or when the server does not support SMTP secure connection (SSL connection).
Connection to SMTP server failed. Change Secure Connection to SSL/TLS.	This message appears when an SMTP mismatch occurs between a server and a client, or when the server requests to use an SSL/TLS connection for an SMTP secure connection.
Connection to SMTP server failed. Change Secure Connection to STARTTLS.	This message appears when an SMTP mismatch occurs between a server and a client, or when the server requests to use an STARTTLS connection for an SMTP secure connection.
The connection is untrusted. Check the following. - Date and Time	This message appears when the printer's date and time setting is incorrect or the certificate has expired.
The connection is untrusted. Check the following. - CA Certificate	This message appears when the printer does not have a root certificate corresponding to the server or a CA Certificate has not been imported.
The connection is not secured.	This message appears when the obtained certificate is damaged.
SMTP server authentication failed. Change Authentication Method to SMTP-AUTH.	This message appears when an authentication method mismatch occurs between a server and a client. The server supports SMTP AUTH.
SMTP server authentication failed. Change Authentication Method to POP before SMTP.	This message appears when an authentication method mismatch occurs between a server and a client. The server does not support SMTP AUTH.
Sender's Email Address is incorrect. Change to the email address for your email service.	This message appears when the specified sender's Email address is wrong.
Cannot access the printer until processing is complete.	This message appears when the printer is busy.

## Making Basic Operation Settings for the Printer

### Setting the Control Panel

Setup for the printer's control panel. You can set up as follows.

1. Access Web Config and select the **Device Management** tab > **Control Panel**.
2. Set up the following items as necessary.
  - Language  
Select the displayed language on the control panel.

Panel Lock

If you select **ON**, the administrator password is required when you perform an operation that requires the administrator's authority. If the administrator password is not set, panel lock is disabled.

Operation Timeout

If you select **ON**, when you log in as the access control user or administrator, you are automatically logged out and go to the initial screen if there is no activity for a certain period of time.

You can set between 10 seconds and 240 minutes by the second.

**Note:**

*You can also set up from the printer's control panel.*

*Language : Settings > General Settings > Basic Settings > Language*

*Panel Lock : Settings > General Settings > System Administration > Security Settings > Admin Settings > Lock Setting*

*Operation Timeout : Settings > General Settings > Basic Settings > Operation Time Out (You can specify On or Off.)*

3. Click **OK**.

## Power Saving Settings

You can set up the time to shift to the power saving mode or to turn the power off when the printer's control panel is not operated for a certain period of time. Set the time depending on your usage environment.

### Setting the Sleep Timer

You can set up the time to switch to power saving mode when inactivity occurs.

1. Access Web Config and select the **Device Management** tab > **Power Saving**.
2. Enter the time to switch to power saving mode for the **Sleep Timer** when inactivity occurs.  
You can set up to 120 minutes by the minute.
3. Click **OK**.

**Note:**

*You can also set up from the printer's control panel.*

**Settings > General Settings > Basic Settings > Sleep Timer**

### Setting Quick Sleep

You can switch to power saving mode immediately after printing.

1. Access Web Config and select the **Device Management** tab > **Power Saving**.
2. Set **Quick Sleep** to **ON**(default).
3. Click **OK**.

**Note:**

You can also set up from the printer's control panel.

Settings > General Settings > Basic Settings > Quick Sleep

**Making a Weekly Sleep Schedule**

You can set a sleep pattern according to the usage activity. Use Web Config to make this setting.

1. Access Web Config and select the **Device Management** tab > **Power Saving** > **Sleep Schedule**.
2. Set the **Start Time** and **Power Saving Mode** for each of the five time periods.

You can select the following **Power Saving Mode** options.

**On**

Enters sleep mode according to the **Sleep Timer** settings.

**Quick**

Enters sleep mode immediately when inactivity occurs.

For example, if you want the printer to sleep on Monday as shown in the following figure, make settings as shown in the Sleep Schedule screenshot below.

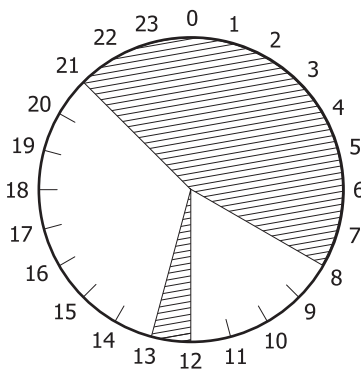

During this time period, it enters sleep mode immediately.

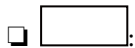

During this time period, it enters sleep mode according to the **Sleep Timer** settings.

Pattern	Time1		Time2		Time3		Time4		Time5	
	Start Time	Power Saving Mode	Start Time	Power Saving Mode	Start Time	Power Saving Mode	Start Time	Power Saving Mode	Start Time	Power Saving Mode
Monday	00:00	Quick	08:00	On	12:00	Quick	13:00	On	21:00	Quick
Tuesday	00:00	On	24:00	On	24:00	On	24:00	On	24:00	On
Wednesday	00:00	On	24:00	On	24:00	On	24:00	On	24:00	On
Thursday	00:00	On	24:00	On	24:00	On	24:00	On	24:00	On
Friday	00:00	On	24:00	On	24:00	On	24:00	On	24:00	On
Saturday	00:00	On	24:00	On	24:00	On	24:00	On	24:00	On
Sunday	00:00	On	24:00	On	24:00	On	24:00	On	24:00	On

3. Click OK.



### **Making Settings to Power Off when All Ports are Disconnected**

Set the printer to turn off automatically after 30 minutes when all ports including the USB port are disconnected.

This feature may not be available depending on your region.

1. Access Web Config and select the **Device Management** tab > **Power Saving**.
2. Set **Power Off If Disconnected** to **On**.
3. Click **OK**.

**Note:**

*You can also set up from the printer's control panel.*

**Settings > General Settings > Basic Settings > Power Off If Disconnected**

### **Synchronizing the Date and Time with Time Server**

When synchronizing with the time server (NTP server), you can synchronize the time of the printer and the computer on the network. The time server may be operated within the organization or published on the Internet.

When using the CA certificate or Kerberos authentication, time-related trouble can be prevented by synchronizing with the time server.

1. Access Web Config and select the **Device Management** tab > **Date and Time** > **Time Server**.
2. Select **Use** for **Use Time Server**.
3. Enter the time server address for **Time Server Address**.  
You can use IPv4, IPv6 or FQDN format. Enter 252 characters or less. If you do not specify this, leave it blank.
4. Enter **Update Interval (min)**.  
You can set up to 10,080 minutes by the minute.
5. Click **OK**.

**Note:**

*You can confirm the connection status with the time server on **Time Server Status**.*

## **Problems when Making Settings**

### **Hints to Solving Problems**

- Checking the error message

When trouble has occurred, first check whether there are any messages on the printer's control panel or driver screen. If you have the notification email set when the events occur, you can promptly learn the status.

- Network connection report

Diagnose the network and the printer status, and then print the result.

You can find the diagnosed error from the printer side.

Checking the communication status

Check the communication status of server computer or client computer by using the command such as ping and ipconfig.

Connection test

For checking the connection between the printer to the mail server, perform the connection test from the printer. Also, check the connection from the client computer to the server to check the communication status.

Initializing the settings

If the settings and communication status show no problem, the problems may be solved by disabling or initializing the network settings of the printer, and then setting up again.

## Cannot Access Web Config

The IP address is not assigned to the printer.

A valid IP address may not be assigned to the printer. Configure the IP address using the printer's control panel. You can confirm the current setting information with a network status sheet or from the printer's control panel.

Web browser does not support the Encryption Strength for SSL/TLS.

SSL/TLS has the Encryption Strength. You can open Web Config by using a web browser that supports bulk encryptions as indicated below. Check you are using the a supported browser.

- 80bit: AES256/AES128/3DES
- 112bit: AES256/AES128/3DES
- 128bit: AES256/AES128
- 192bit: AES256
- 256bit: AES256

CA-signed Certificate is expired.

If there is a problem with the expiration date of the certificate, "The certificate has expired" is displayed when connecting to Web Config with SSL/TLS communication (https). If the message appears before its expiration date, make sure that the printer's date is configured correctly.

The common name of the certificate and the printer do not match.

If the common name of the certificate and the printer do not match, the message "The name of the security certificate does not match..." is displayed when accessing Web Config using SSL/TLS communication (https). This happens because the following IP addresses do not match.

- The printer's IP address entered to common name for creating a Self-signed Certificate or CSR
- IP address entered to web browser when running Web Config

For Self-signed Certificate, update the certificate.

For CA-signed Certificate, take the certificate again for the printer.

The proxy server setting of local address is not set to web browser.

When the printer is set to use a proxy server, configure the web browser not to connect to the local address via the proxy server.

❑ Windows:

Select **Control Panel > Network and Internet > Internet Options > Connections > LAN settings > Proxy server**, and then configure not to use the proxy server for LAN (local addresses).

❑ Mac OS:

Select **System Preferences > Network > Advanced > Proxies**, and then register the local address for **Bypass proxy settings for these Hosts & Domains**.

Example:

192.168.1.\*: Local address 192.168.1.XXX, subnet mask 255.255.255.0

192.168.\*.\*: Local address 192.168.XXX.XXX, subnet mask 255.255.0.0

## Managing the Printer

### Introduction of Product Security Features

This section introduces the security function of the Epson Devices.

Feature name	Feature type	What to set	What to prevent
Setup for the administrator password	Locks the system settings, such as connection setup for network or USB.	An administrator sets a password to the device.  You can set or change from both Web Config and the printer's control panel.	Prevent from illegally reading and changing the information stored in the device such as ID, password, network settings, and so on. Also, reduce a wide range of security risks such as leakage of information for the network environment or security policy.
Setup for access control	If you log on with a user account registered in advance, you are allowed to use the printer.  Protects from illegal access by any system other than the authentication system when using it.	Register any user account.  You can register up to 10 user accounts.	The risk of leakage and unauthorized viewing of data can be reduced by minimizing the numbers of functions in accordance with the business content and the role of the user.
Setup for external interface	Controls the interface that connects to the device.	Enable or disable USB connection with the computer.	❑ USB connection of computer: Prevents unauthorized use of the device by prohibiting printing without going through the network.

#### Related Information

- ➔ [“Application for Configuring Printer Operations \(Web Config\)” on page 221](#)
- ➔ [“Configuring the Administrator Password” on page 244](#)
- ➔ [“Restricting Available Features” on page 249](#)
- ➔ [“Disabling the External Interface” on page 251](#)

## Administrator Settings

### Configuring the Administrator Password

When you set the administrator password, you can prevent the users from changing system management settings. You can set and change the administrator password using either Web Config, the printer's control panel, or Epson Device Admin. When using Epson Device Admin, see the Epson Device Admin guide or help.

#### Related Information

- ➔ [“Application for Configuring Printer Operations \(Web Config\)” on page 221](#)
- ➔ [“Software for Managing Devices on the Network \(Epson Device Admin\)” on page 223](#)

### Configuring the Administrator Password from the Control Panel

You can set the administrator password from the printer's control panel.

1. Select **Settings** on the printer's control panel.
2. Select **General Settings > System Administration > Security Settings > Admin Settings**.
3. Select **Admin Password > Register**.
4. Enter the new password.
5. Enter the password again.

#### Note:

*You can change or delete the administrator password when you select **Change** or **Restore Default Settings** on the **Admin Password** screen and enter the administrator password.*

### Configuring the Administrator Password from a Computer

You can set the administrator password using Web Config.

1. Access Web Config and select the **Product Security** tab > **Change Administrator Password**.
2. Enter a password to **New Password** and **Confirm New Password**. Enter the user name, if necessary.  
If you want to change the password to new one, enter a current password.
3. Select **OK**.

#### Note:

- To set or change the locked menu items, click **Administrator Login**, and then enter the administrator password.
- To delete the administrator password, click **Product Security** tab > **Delete Administrator Password**, and then enter the administrator password.

#### Related Information

- ➔ [“Application for Configuring Printer Operations \(Web Config\)” on page 221](#)

## Controlling the Panel Operation

If you set the administrator password and enable the Lock Setting, you can lock the items related to the printer's system settings so that users cannot change them.

### Enabling the Lock Setting

Enable the Lock Setting for the printer where the password is set.

Specify an administrator's password first.

### Enabling the Lock Setting from the Control Panel

1. Select **Settings** on the printer's control panel.
2. Select **General Settings > System Administration > Security Settings > Admin Settings**.
3. Select **On** on **Lock Setting**.

Select **Settings > General Settings > Network Settings**, and then check that the password is required.

### Enabling the Lock Setting from a Computer

1. Access Web Config and click the **Administrator Login**.
2. Enter the user name and password, and then click **OK**.
3. Select the **Device Management** tab > **Control Panel**.
4. On the **Panel Lock**, select **ON**.
5. Click **OK**.
6. Select **Settings > General Settings > Network Settings** on the printer's control panel, and then check that the password is required.

### Related Information

➔ [“Application for Configuring Printer Operations \(Web Config\)” on page 221](#)

### Lock Setting Items for General Settings Menu

This is a list of the Lock Setting items in **Settings > General Settings** on the control panel.

Some items are only displayed when optional items are installed.

General Settings menu	Panel Lock
Basic Settings	-

General Settings menu		Panel Lock
	LCD Brightness	-
	Sound	-
	Sleep Timer	✓
	Quick Sleep	✓
	Power Off If Disconnected	✓
	Date/Time Settings	✓
	Language	✓
	Operation Time Out	✓
	Keyboard	-

General Settings menu		Panel Lock
Printer Settings		-
	Paper Source Settings	-
	Output Tray	-
	Printing Language	✓
	Universal Print Settings	✓
	PDL Print Configuration	✓
	Auto Error Solver	✓
	PC Connection via USB	✓
	USB I/F Timeout Setting	✓
	Printer Swapping	-

General Settings menu		Panel Lock
Network Settings		✓

General Settings menu		Panel Lock
	Network Status	✓
	Wired LAN Status	✓ <sup>*1</sup>
	Print Status Sheet	✓ <sup>*1</sup>
	Connection Check	✓
	Advanced	✓
	Device Name	✓
	TCP/IP	✓
	Proxy Server	✓
	IPv6 Address	✓
	Link Speed & Duplex	✓
	Redirect HTTP to HTTPS	✓
	Disable IPsec/IP Filtering	✓
	Disable IEEE802.1X	✓

General Settings menu		Panel Lock
	Web Service Settings	✓
	Epson Connect Services	✓

General Settings menu		Panel Lock
	System Administration	✓

General Settings menu		Panel Lock
Reset number of consumed toner Compatible models: AL-M8250DN, AL-M8150DN		✓
Clear Internal Memory Data		✓
HDD Erase Settings* <sup>2</sup>		✓
Option HDD invalid* <sup>2</sup>		✓
Security Settings		✓
Delete All Internal Memory Jobs		✓
Admin Settings		✓
	Admin Password	✓
	Lock Setting	✓
Password Encryption		✓
Audit Log		✓
Customer Research		✓
Printer Adjust Menu		✓
Restore Default Settings		✓
Firmware Update		✓

✓ = To be locked.

- = Not to be locked.

\*1 : Even though items on the upper level can be locked by administrator lock, you can still access them from the same name menu of **Settings > Printer Status/Print > Network**.

\*2 : This item is displayed when the optional hard disk unit is installed.

### Related Information

➔ [“HDD \(AL-M8250DN/AL-M8150DN Only\)” on page 158](#)

## Logging on to the Printer as an Administrator

If the administrator password is set to the printer, you need to log on as an administrator to operate the locked menu items on Web Config.

Enter the password to operate the locked menu items on the control panel.

### Logging on to the Printer from a Computer

When you log in to Web Config as an administrator, you can operate items that are set in the Lock Setting.

1. Enter the printer's IP address into a browser to run Web Config.



2. Click **Administrator Login**.
3. Enter the user name and administrator password in **User Name** and **Current password**.
4. Click **OK**.

The locked items and **Administrator Logout** are displayed when being authenticated.

Click **Administrator Logout** to log off.

**Note:**

When you select **ON** for the **Device Management** tab > **Control Panel** > **Operation Timeout**, you log off automatically after a specific length of time if there is no activity on the control panel.

**Related Information**

➔ [“Application for Configuring Printer Operations \(Web Config\)” on page 221](#)

## Restricting Available Features

You can register user accounts on the printer, link them with functions, and control functions that users can use.

When you register the authentication information to the printer driver, you will be able to print from the computer. For details of the driver settings, see the driver's help or manual.

## Creating the User Account

Create the user account for access control.

1. Access Web Config and select the **Product Security** tab > **Access Control Settings** > **User Settings**.
2. Click **Add** for the number you want to register.



**Important:**

When using the printer with the authentication system of Epson or other companies, register the user name of the restriction setting in number 2 to number 10.

Application software such as the authentication system uses number one, so that the user name is not displayed on the printer's control panel.

3. Set each item.
  - User Name :**  
Enter the name displayed on the user name list between 1 and 14 characters long using alphanumeric characters.
  - Password :**  
Enter a password between 0 and 20 characters long in ASCII (0x20-0x7E). When initializing the password, leave it blank.
  - Select the check box to enable or disable each function.  
Select the function that you permit to use.

4. Click **Apply**.

Return to the user setting list after a specific length of time.

Check that the user name you registered on **User Name** is displayed and changed **Add** to **Edit**.

#### **Related Information**

➔ [“Application for Configuring Printer Operations \(Web Config\)” on page 221](#)

### ***Editing the User Account***

Edit the account registered to access control.

1. Access Web Config and select the **Product Security** tab > **Access Control Settings** > **User Settings**.
2. Click **Edit** for the number you want to edit.
3. Change each item.
4. Click **Apply**.  
Return to the user setting list after a specific length of time.

#### **Related Information**

➔ [“Application for Configuring Printer Operations \(Web Config\)” on page 221](#)

### ***Deleting the User Account***

Delete the account registered to access control.

1. Access Web Config and select the **Product Security** tab > **Access Control Settings** > **User Settings**.
2. Click **Edit** for the number you want to delete.
3. Click **Delete**.



***Important:***

*When clicking **Delete**, the user account will be deleted without a confirmation message. Take care when deleting the account.*

Return to the user setting list after a specific length of time.

#### **Related Information**

➔ [“Application for Configuring Printer Operations \(Web Config\)” on page 221](#)

### **Enabling Access Control**

When enabling access control, only the registered user will be able to use the printer.

1. Access Web Config and select the **Product Security** tab > **Access Control Settings** > **Basic**.

2. Select **Enables Access Control**.

If you select **Allow printing and scanning without authentication information from a computer**, you can print from the drivers that are not set with the authentication information.

3. Click **OK**.

### Related Information

➔ [“Application for Configuring Printer Operations \(Web Config\)” on page 221](#)

## Disabling the External Interface

You can disable the interface that is used to connect the device to the printer. Make the restriction settings to restrict printing other than via network.

### Note:

*You can also make the restriction settings on the printer's control panel.*

*PC Connection via USB : **Settings** > **General Settings** > **Printer Settings** > **PC Connection via USB***

1. Access Web Config and select the **Product Security** tab > **External Interface**.

2. Select **Disable** on the functions you want to set.

Select **Enable** when you want to cancel controlling.

PC Connection via USB

You can restrict the usage of the USB connection from the computer. If you want to restrict it, select **Disable**.

3. Click **OK**.

4. Check that the disabled port cannot be used.

PC Connection via USB

If the driver was installed on the computer

Connect the printer to the computer using a USB cable, and then confirm that the printer does not print.

If the driver was not installed on the computer

Windows:

Open the device manager and keep it, connect the printer to the computer using a USB cable, and then confirm that the device manager's display contents stays unchanged.

Mac OS:

Connect the printer to the computer using a USB cable, and then confirm that the printer is not listed if you want to add the printer from **Printers & Scanners**.

### Related Information

➔ [“Application for Configuring Printer Operations \(Web Config\)” on page 221](#)

## Monitoring a Remote Printer

### Checking Information for a Remote Printer

You can check the following information of the operating printer from **Status** by using Web Config.

Product Status

Check the status, cloud service, product number, MAC address, etc.

Network Status

Check the information of the network connection status, IP address, DNS server, etc.

Usage Status

Check the first day of printings, printed pages, printing count for each language, etc.

Hardware Status

Check the status of each function of the printer.

Panel Snapshot

Display a screen image snapshot that is displayed on the control panel of the device.

#### Related Information

➔ [“Application for Configuring Printer Operations \(Web Config\)” on page 221](#)

## Receiving Email Notifications When Events Occur

### About Email Notifications

This is the notification function that, when events such as printing stop and printer error occur, send the email to the specified address.

You can register up to five destinations and set the notification settings for each destination.

To use this function, you need to set up the mail server before setting up notifications.

#### Related Information

➔ [“Configuring a Mail Server” on page 235](#)

### Configuring Email Notification

Configure email notification by using Web Config.

1. Access Web Config and select the **Device Management** tab > **Email Notification**.
2. Set the subject of email notification.  
Select the contents displayed on the subject from the two pull-down menus.
  - The selected contents are displayed next to **Subject**.
  - The same contents cannot be set on left and right.

- ❑ When the number of characters in **Location** exceeds 32 bytes, characters exceeding 32 bytes are omitted.
- 3. Enter the email address for sending the notification email.  
Use A-Z a-z 0-9 ! # \$ % & ' \* + - . / = ? ^ \_ { | } ~ @, and enter between 1 and 255 characters.
- 4. Select the language for the email notifications.
- 5. Select the check box on the event for which you want to receive a notification.  
The number of **Notification Settings** is linked to the destination number of **Email Address Settings**.  
Example :  
If you want a notification sent to the email address set for number 1 in **Email Address Settings** when the printer is out of paper, select the check box column **1** in line **Paper out**.
- 6. Click **OK**.  
Confirm that an email notification will be sent by causing an event.  
Example : Print by specifying the Paper Source where paper is not set.

**Related Information**

- ➔ [“Application for Configuring Printer Operations \(Web Config\)” on page 221](#)
- ➔ [“Configuring a Mail Server” on page 235](#)

**Items for Email Notification**

Items	Settings and Explanation
Replacing toner cartridge is required	Notification displayed when the toner is expended.
Toner low	Notification displayed when the toner is nearly expended.
Administrator password changed	Notification displayed when administrator password has been changed.
Paper out	Notification displayed when the paper-out error has occurred in the specified paper source.
Printing stopped	Notification displayed when the printing is stopped due to paper jam or paper cassette not set.
Printer error	Notification displayed when the printer error has occurred.
hard disk unit error	Notification displayed when the error of the internal hard disk. This item is displayed when the optional hard disk unit is installed.
Additional Network failure	Notification displayed when an error in the additional network interface card has occurred. This item is displayed when the additional network interface card is installed.

**Related Information**

- ➔ [“Configuring Email Notification” on page 252](#)

## Backing Up the Settings

You can export the setting value set from Web Config to the file. You can use it for backing up the setting values, replacing the printer, etc.

The exported file cannot be edited because it is exported as a binary file.

### Export the settings

Export the setting for the printer.

1. Access Web Config, and then select the **Device Management** tab > **Export and Import Setting Value** > **Export**.

2. Select the settings that you want to export.

Select the settings you want to export. If you select the parent category, subcategories are also selected.

However, subcategories that cause errors by duplicating within the same network (such as IP addresses and so on) cannot be selected.

3. Enter a password to encrypt the exported file.

You need the password to import the file. Leave this blank if you do not want to encrypt the file.

4. Click **Export**.

 **Important:**

*If you want to export the printer's network settings such as the device name and IPv6 address, select **Enable to select the individual settings of device** and select more items. Only use the selected values for the replacement printer.*

### Related Information

➔ [“Application for Configuring Printer Operations \(Web Config\)” on page 221](#)

### Import the settings

Import the exported Web Config file to the printer.

 **Important:**

*When importing values that include individual information such as a printer name or IP address, make sure the same IP address does not exist on the same network.*

1. Access Web Config, and then select the **Device Management** tab > **Export and Import Setting Value** > **Import**.

2. Select the exported file, and then enter the encrypted password.

3. Click **Next**.

4. Select the settings that you want to import, and then click **Next**.
5. Click **OK**.

The settings are applied to the printer.

#### Related Information

➔ [“Application for Configuring Printer Operations \(Web Config\)” on page 221](#)

---

## Advanced Security Settings

This section explains advanced security features.

### Security Settings and Prevention of Danger

When a printer is connected to a network, you can access it from a remote location. In addition, many people can share the printer, which is helpful in improving operational efficiency and convenience. However, risks such as illegal access, illegal use, and tampering with data are increased. If you use the printer in an environment where you can access the Internet, the risks are even higher.

For printers that do not have access protection from the outside, it will be possible to read the print job logs that are stored in the printer from the Internet.

In order to avoid this risk, Epson printers have a variety of security technologies.

Set the printer as necessary according to the environmental conditions that have been built with the customer's environment information.

Name	Feature type	What to set	What to prevent
Control of protocol	Controls the protocols and services to be used for communication between printers and computers, and it enables and disables features.	A protocol or service that is applied to features allowed or prohibited separately.	Reducing security risks that may occur through unintended use by preventing users from using unnecessary functions.
SSL/TLS communications	The communication content is encrypted with SSL/TLS communications when accessing to the Epson server on the Internet from the printer, such as communicating to the computer via web browser, using Epson Connect, and updating firmware.	Obtain a CA-signed certificate, and then import it to the printer.	Clearing an identification of the printer by the CA-signed certification prevents impersonation and unauthorized access. In addition, communication contents of SSL/TLS are protected, and it prevents the leakage of contents for printing data and setup information.

Name	Feature type	What to set	What to prevent
IPsec/IP filtering	You can set to allow severing and cutting off of data that is from a certain client or is a particular type. Since IPsec protects the data by IP packet unit (encryption and authentication), you can safely communicate unsecured protocol.	Create a basic policy and individual policy to set the client or type of data that can access the printer.	Protect unauthorized access, and tampering and interception of communication data to the printer.
IEEE802.1X	Only allows authenticated users to connect to the network. Allows only a permitted user to use the printer.	Authentication setting to the RADIUS server (authentication sever).	Protect unauthorized access and use to the printer.

### Related Information

- ➔ [“Controlling Using Protocols” on page 256](#)
- ➔ [“SSL/TLS Communication with the Printer” on page 267](#)
- ➔ [“Encrypted Communication Using IPsec/IP Filtering” on page 268](#)
- ➔ [“Connecting the Printer to an IEEE802.1X Network” on page 279](#)

## Security Feature Settings

When setting IPsec/IP filtering or IEEE802.1X, it is recommended that you access Web Config using SSL/TLS to communicate settings information in order to reduce security risks such as tampering or interception.

Make sure you configure the administrator password before setting IPsec/IP filtering or IEEE802.1X.

Also, you can use Web Config by connecting the printer directly to the computer using an Ethernet cable, and then entering the IP address into a web browser. The printer can be connected in a secure environment after the security settings have been completed.

## Controlling Using Protocols

You can print using a variety of pathways and protocols.

You can lower unintended security risks by restricting printing from specific pathways or by controlling the available functions.

### Controlling protocols

Configure the protocol settings.

1. Access Web Config and then select the **Network Security** tab > **Protocol**.
2. Configure each item.
3. Click **Next**.



4. Click **OK**.

The settings are applied to the printer.

**Related Information**

- ➔ [“Application for Configuring Printer Operations \(Web Config\)” on page 221](#)
- ➔ [“Protocols you can Enable or Disable” on page 257](#)
- ➔ [“Protocol Setting Items” on page 258](#)

**Protocols you can Enable or Disable**

Protocol	Description
Bonjour Settings	You can specify whether to use Bonjour. Bonjour is used to search for devices, print, and so on.
SLP Settings	You can enable or disable the SLP function. SLP is used for push scanning and network searching in EpsonNet Config.
WSD Settings	You can enable or disable the WSD function. When this is enabled, you can add WSD devices, and print from the WSD port.
LLTD Settings	You can enable or disable the LLTD function. When this is enabled, it is displayed on the Windows network map.
LLMNR Settings	You can enable or disable the LLMNR function. When this is enabled, you can use name resolution without NetBIOS even if you cannot use DNS.
LPR Settings	You can specify whether or not to allow LPR printing. When this is enabled, you can print from the LPR port.
RAW(Port9100) Settings	You can specify whether or not to allow printing from the RAW port (Port 9100). When this is enabled, you can print from the RAW port (Port 9100).
RAW(Custom Port) Settings	You can specify whether or not to allow printing from the RAW port (custom port). When this is enabled, you can print from the RAW port (custom port).
IPP Settings	You can specify whether or not to allow printing from IPP. When this is enabled, you can print over the Internet.
FTP Settings	You can specify whether or not to allow FTP printing. When this is enabled, you can print over an FTP server.
SNMPv1/v2c Settings	You can specify whether or not to enable SNMPv1/v2c. This is used to set up devices, monitoring, and so on.
SNMPv3 Settings	You can specify whether or not to enable SNMPv3. This is used to set up encrypted devices, monitoring, etc.

**Related Information**

- ➔ [“Controlling protocols” on page 256](#)
- ➔ [“Protocol Setting Items” on page 258](#)

## Protocol Setting Items

### Bonjour Settings

Items	Setting value and Description
Use Bonjour	Select this to search for or use devices through Bonjour. Default : Enable
Bonjour Name	Displays the Bonjour name.
Bonjour Service Name	Displays the Bonjour service name.
Location	Displays the Bonjour location name.
Top Priority Protocol	Select the top priority protocol for Bonjour print. Default : IPP
Wide-Area Bonjour	Set whether to use Wide-Area Bonjour. Default : Do Not Use

### SLP Settings

Items	Setting value and Description
Enable SLP	Select this to enable the SLP function. This is used such as network searching in EpsonNet Config. Default : Enable

### WSD Settings

Items	Setting value and Description
Enable WSD	Select this to enable adding devices using WSD, and print from the WSD port. Default : Enable
Printing Timeout (sec)	Enter the communication timeout value for WSD printing between 3 to 3,600 seconds. Default : 300
Device Name	Displays the WSD device name.
Location	Displays the WSD location name.

### LLTD Settings

Items	Setting value and Description
Enable LLTD	Select this to enable LLTD. The printer is displayed in the Windows network map. Default : Enable
Device Name	Displays the LLTD device name.

LLMNR Settings

Items	Setting value and Description
Enable LLMNR	Select this to enable LLMNR. You can use name resolution without NetBIOS even if you cannot use DNS. Default : Enable

LPR Settings

Items	Setting value and Description
Allow LPR Port Printing	Select to allow printing from the LPR port. Default : Enable
Printing Timeout (sec)	Enter the timeout value for LPR printing between 0 to 3,600 seconds. If you do not want to timeout, enter 0. Default : 300

RAW(Port9100) Settings

Items	Setting value and Description
Allow RAW(Port9100) Printing	Select to allow printing from the RAW port (Port 9100). Default : Enable
Printing Timeout (sec)	Enter the timeout value for RAW (Port 9100) printing between 0 to 3,600 seconds. If you do not want to timeout, enter 0. Default : 300

RAW(Custom Port) Settings

Items	Setting value and Description
Allow RAW(Custom Port) Printing	Select to allow printing from the RAW port (custom port). Default : Enable
Port Number	Enter the port number for RAW printing between 1024 and 65535 (except for 9100, 1865, 2968). Default : 2501
Printing Timeout (sec)	Enter the timeout value for RAW (custom port) printing between 0 to 3,600 seconds. If you do not want to timeout, enter 0. Default : 300

IPP Settings

Items	Setting value and Description
Enable IPP	Select to enable IPP communication. Only printers that support IPP are displayed. Default : Enable
Allow Non-secure Communication	Select <b>Allowed</b> to allow the printer to communicate without any security measures (IPP). Default : Not Allowed
Communication Timeout (sec)	Enter the timeout value for IPP printing between 0 to 3,600 seconds. Default : 300
Require PIN Code when using IPP printing	Select whether or not to require a PIN code when using IPP printing. If you select <b>Yes</b> , IPP print jobs without PIN codes are not saved in the printer. Default : No
URL(Network)	Displays IPP URLs (http and https) when the printer is connected to the network. The URL is a combined value of the printer's IP address, Port number, and IPP printer name.
Printer Name	Displays the IPP printer name. Default : ipp/print
Location	Displays the IPP location.

#### FTP Settings

Items	Setting value and Description
Enable FTP Server	Select to enable FTP printing. Only printers that support FTP printing are displayed. Default : Disable
Communication Timeout (sec)	Enter the timeout value for FTP communication between 0 to 3,600 seconds. If you do not want to timeout, enter 0. Default : 120

#### SNMPv1/v2c Settings

Items	Setting value and Description
Enable SNMPv1/v2c	Select to enable SNMPv1/v2c. Default : Enable
Access Authority	Set the access authority when SNMPv1/v2c is enabled. Select <b>Read Only</b> or <b>Read/Write</b> . Default : Read/Write
Community Name (Read Only)	Enter 0 to 32 ASCII (0x20 to 0x7E) characters. Default : public
Community Name (Read/Write)	Enter 0 to 32 ASCII (0x20 to 0x7E) characters.

## SNMPv3 Settings

Items	Setting value and Description
Enable SNMPv3	SNMPv3 is enabled when the box is checked. Default : Disable
User Name	Enter between 1 and 32 characters using 1 byte characters. Default : admin
Authentication Settings	
Algorithm	Select an algorithm for an authentication for SNMPv3. Default : MD5
Password	Enter the password for an authentication for SNMPv3. Enter between 8 and 32 characters in ASCII (0x20-0x7E). If you do not specify this, leave it blank.
Confirm Password	Enter the password you configured for confirmation.
Encryption Settings	
Algorithm	Select an algorithm for an encryption for SNMPv3. Default : DES
Password	Enter the password for an encryption for SNMPv3. Enter between 8 and 32 characters in ASCII (0x20-0x7E). If you do not specify this, leave it blank.
Confirm Password	Enter the password you configured for confirmation.
Context Name	Enter within 32 characters or less in Unicode (UTF-8). If you do not specify this, leave it blank. The number of characters that can be entered varies depending on the language. Default : EPSON

### Related Information

- ➔ [“Controlling protocols” on page 256](#)
- ➔ [“Protocols you can Enable or Disable” on page 257](#)

## Using a Digital Certificate

### About Digital Certification

#### CA-signed Certificate

This is a certificate signed by the CA (Certificate Authority.) You can obtain it to apply to the Certificate Authority. This certificate certifies the existence of the printer is and used for SSL/TLS communication so that you can ensure the safety of data communication.

When it is used for SSL/TLS communication, it is used as a server certificate.

When it is set to IPsec/IP Filtering or IEEE802.1x communication, it is used as a client certificate.

❑ CA Certificate

This is a certificate that is in chain of the CA-signed Certificate, also called the intermediate CA certificate. It is used by the web browser to validate the path of the printer's certificate when accessing the server of the other party or Web Config.

For the CA Certificate, set when to validate the path of server certificate accessing from the printer. For the printer, set to certify the path of the CA-signed Certificate for SSL/TLS connection.

You can obtain the CA certificate of the printer from the Certification Authority where the CA certificate is issued.

Also, you can obtain the CA certificate used to validate the server of the other party from the Certification Authority that issued the CA-signed Certificate of the other server.

❑ Self-signed Certificate

This is a certificate that the printer signs and issues itself. It is also called the root certificate. Because the issuer certifies itself, it is not reliable and cannot prevent impersonation.

Use it when making the security setting and performing simple SSL/TLS communication without the CA-signed Certificate.

If you use this certificate for an SSL/TLS communication, a security alert may be displayed on a web browser because the certificate is not registered on a web browser. You can use the Self-signed Certificate only for an SSL/TLS communication.

### Related Information

- ➔ [“Configuring a CA-signed Certificate” on page 262](#)
- ➔ [“Updating a Self-signed Certificate” on page 265](#)
- ➔ [“Configuring a CA Certificate” on page 266](#)

## Configuring a CA-signed Certificate

### Obtaining a CA-signed Certificate

To obtain a CA-signed certificate, create a CSR (Certificate Signing Request) and apply it to certificate authority. You can create a CSR using Web Config and a computer.

Follow the steps to create a CSR and obtain a CA-signed certificate using Web Config. When creating a CSR using Web Config, a certificate is the PEM/DER format.

1. Access Web Config, and then select the **Network Security** tab. Next, select **SSL/TLS > Certificate** or **IPsec/IP Filtering > Client Certificate** or **IEEE802.1X > Client Certificate**.

Whatever you choose, you can obtain the same certificate and use it in common.

2. Click **Generate** of **CSR**.

A CSR creating page is opened.

3. Enter a value for each item.

**Note:**

*Available key length and abbreviations vary by a certificate authority. Create a request according to rules of each certificate authority.*

4. Click **OK**.  
A completion message is displayed.
5. Select the **Network Security** tab. Next, select **SSL/TLS > Certificate**, or **IPsec/IP Filtering > Client Certificate** or **IEEE802.1X > Client Certificate**.
6. Click one of the download buttons of **CSR** according to a specified format by each certificate authority to download a CSR to a computer.



**Important:**

*Do not generate a CSR again. If you do so, you may not be able to import an issued CA-signed Certificate.*

7. Send the CSR to a certificate authority and obtain a CA-signed Certificate.  
Follow the rules of each certificate authority on sending method and form.
8. Save the issued CA-signed Certificate to a computer connected to the printer.  
Obtaining a CA-signed Certificate is complete when you save a certificate to a destination.

**Related Information**

➔ [“Application for Configuring Printer Operations \(Web Config\)” on page 221](#)

**CSR Setting Items**

Items	Settings and Explanation
Key Length	Select a key length for a CSR.
Common Name	<p>You can enter between 1 and 128 characters. If this is an IP address, it should be a static IP address. You can enter 1 to 5 IPv4 addresses, IPv6 addresses, host names, FQDNs by separating them with commas.</p> <p>The first element is stored to the common name, and other elements are stored to the alias field of the certificate subject.</p> <p>Example: Printer's IP address : 192.0.2.123, Printer name : EPSONA1B2C3 Common Name : EPSONA1B2C3,EPSONA1B2C3.local,192.0.2.123</p>
Organization/ Organizational Unit/ Locality/ State/Province	You can enter between 0 and 64 characters in ASCII (0x20-0x7E). You can divide distinguished names with commas.
Country	Enter a country code in two-digit number specified by ISO-3166.
Sender's Email Address	You can enter the sender's email address for the mail server setting. Enter the same email address as the <b>Sender's Email Address</b> for the <b>Network</b> tab > <b>Email Server &gt; Basic</b> .

**Related Information**

➔ [“Obtaining a CA-signed Certificate” on page 262](#)

### Importing a CA-signed Certificate

Import the obtained CA-signed Certificate to the printer.



**Important:**

- Make sure that the printer's date and time is set correctly. Certificate may be invalid.
- If you obtain a certificate using a CSR created from Web Config, you can import a certificate one time.

1. Access Web Config and then select the **Network Security** tab. Next, select **SSL/TLS > Certificate**, or **IPsec/IP Filtering > Client Certificate** or **IEEE802.1X > Client Certificate**.

2. Click **Import**

A certificate importing page is opened.

3. Enter a value for each item. Set **CA Certificate 1** and **CA Certificate 2** when verifying the path of the certificate on the web browser that accesses the printer.

Depending on where you create a CSR and the file format of the certificate, required settings may vary. Enter values to required items according to the following.

- A certificate of the PEM/DER format obtained from Web Config
  - Private Key:** Do not configure because the printer contains a private key.
  - Password:** Do not configure.
  - CA Certificate 1/CA Certificate 2:** Optional
- A certificate of the PEM/DER format obtained from a computer
  - Private Key:** You need to set.
  - Password:** Do not configure.
  - CA Certificate 1/CA Certificate 2:** Optional
- A certificate of the PKCS#12 format obtained from a computer
  - Private Key:** Do not configure.
  - Password:** Optional
  - CA Certificate 1/CA Certificate 2:** Do not configure.

4. Click **OK**.

A completion message is displayed.

**Note:**

Click **Confirm** to verify the certificate information.

### Related Information

➔ [“Application for Configuring Printer Operations \(Web Config\)” on page 221](#)



### CA-signed Certificate Importing Setting Items

Items	Settings and Explanation
Server Certificate or Client Certificate	Select a certificate's format. For SSL/TLS connection, the Server Certificate is displayed. For IPsec/IP Filtering or IEEE802.1x, the Client Certificate is displayed.
Private Key	If you obtain a certificate of the PEM/DER format by using a CSR created from a computer, specify a private key file that is match a certificate.
Password	If the file format is <b>Certificate with Private Key (PKCS#12)</b> , enter the password for encrypting the private key that is set when you obtain the certificate.
CA Certificate 1	If your certificate's format is <b>Certificate (PEM/DER)</b> , import a certificate of a certificate authority that issues a CA-signed Certificate used as server certificate. Specify a file if you need.
CA Certificate 2	If your certificate's format is <b>Certificate (PEM/DER)</b> , import a certificate of a certificate authority that issues CA Certificate 1. Specify a file if you need.

#### Related Information

➔ [“Importing a CA-signed Certificate” on page 264](#)

### Deleting a CA-signed Certificate

You can delete an imported certificate when the certificate has expired or when an encrypted connection is no longer necessary.



**Important:**

*If you obtain a certificate using a CSR created from Web Config, you cannot import a deleted certificate again. In this case, create a CSR and obtain a certificate again.*

1. Access Web Config, and then select the **Network Security** tab. Next, select **SSL/TLS > Certificate** or **IPsec/IP Filtering > Client Certificate** or **IEEE802.1X > Client Certificate**.
2. Click **Delete**.
3. Confirm that you want to delete the certificate in the message displayed.

#### Related Information

➔ [“Application for Configuring Printer Operations \(Web Config\)” on page 221](#)

### Updating a Self-signed Certificate

Because the Self-signed Certificate is issued by the printer, you can update it when it has expired or when the content described changes.

1. Access Web Config and select the **Network Security** tab > **SSL/TLS > Certificate**.

2. Click **Update**.

3. Enter **Common Name**.

You can enter up to 5 IPv4 addresses, IPv6 addresses, host names, FQDNs between 1 to 128 characters and separating them with commas. The first parameter is stored to the common name, and the others are stored to the alias field for the subject of the certificate.

Example:

Printer's IP address : 192.0.2.123, Printer name : EPSONA1B2C3

Common name : EPSONA1B2C3,EPSONA1B2C3.local,192.0.2.123

4. Specify a validity period for the certificate.

5. Click **Next**.

A confirmation message is displayed.

6. Click **OK**.

The printer is updated.

**Note:**

You can check the certificate information from *Network Security tab > SSL/TLS > Certificate > Self-signed Certificate* and click **Confirm**.

### **Related Information**

➔ [“Application for Configuring Printer Operations \(Web Config\)” on page 221](#)

## **Configuring a CA Certificate**

When you set the CA Certificate, you can validate the path to the CA certificate of the server that the printer accesses. This can prevent impersonation.

You can obtain the CA Certificate from the Certification Authority where the CA-signed Certificate is issued.

### **Importing a CA Certificate**

Import the CA Certificate to the printer.

1. Access Web Config and then select the **Network Security tab > CA Certificate**.

2. Click **Import**.

3. Specify the CA Certificate you want to import.

4. Click **OK**.

When importing is complete, you are returned to the **CA Certificate** screen, and the imported CA Certificate is displayed.

### Related Information

➔ [“Application for Configuring Printer Operations \(Web Config\)” on page 221](#)

### *Deleting a CA Certificate*

You can delete the imported CA Certificate.

1. Access Web Config and then select the **Network Security** tab > **CA Certificate**.
2. Click **Delete** next to the CA Certificate that you want to delete.
3. Confirm that you want to delete the certificate in the message displayed.
4. Click **Reboot Network**, and then check that the deleted CA Certificate is not listed on the updated screen.

### Related Information

➔ [“Application for Configuring Printer Operations \(Web Config\)” on page 221](#)

## SSL/TLS Communication with the Printer

When the server certificate is set using SSL/TLS (Secure Sockets Layer/Transport Layer Security) communication to the printer, you can encrypt the communication path between computers. Do this if you want to prevent remote and unauthorized access.

### Configuring Basic SSL/TLS Settings

If the printer supports the HTTPS server feature, you can use an SSL/TLS communication to encrypt communications. You can configure and manage the printer using Web Config while ensuring security.

Configure encryption strength and redirect feature.

1. Access Web Config and select the **Network Security** tab > **SSL/TLS** > **Basic**.
2. Select a value for each item.
  - Encryption Strength  
Select the level of encryption strength.
  - Redirect HTTP to HTTPS  
Redirect to HTTPS when HTTP is accessed.
3. Click **Next**.  
A confirmation message is displayed.
4. Click **OK**.  
The printer is updated.

### Related Information

➔ [“Application for Configuring Printer Operations \(Web Config\)” on page 221](#)

## Configuring a Server Certificate for the Printer

1. Access Web Config and select the **Network Security** tab > **SSL/TLS** > **Certificate**.
2. Specify a certificate to use on **Server Certificate**.
  - Self-signed Certificate  
A self-signed certificate has been generated by the printer. If you do not obtain a CA-signed certificate, select this.
  - CA-signed Certificate  
If you obtain and import a CA-signed certificate in advance, you can specify this.
3. Click **Next**.  
A confirmation message is displayed.
4. Click **OK**.  
The printer is updated.

### Related Information

- ➔ [“Application for Configuring Printer Operations \(Web Config\)” on page 221](#)
- ➔ [“Configuring a CA-signed Certificate” on page 262](#)
- ➔ [“Updating a Self-signed Certificate” on page 265](#)

## Encrypted Communication Using IPsec/IP Filtering

### About IPsec/IP Filtering

You can filter traffic based on IP addresses, services, and port by using IPsec/IP Filtering function. By combining of the filtering, you can configure the printer to accept or block specified clients and specified data. Additionally, you can improve security level by using an IPsec.

**Note:**

*Computers that run Windows Vista or later or Windows Server 2008 or later support IPsec.*

### Configuring Default Policy

To filter traffic, configure the default policy. The default policy applies to every user or group connecting to the printer. For more fine-grained control over users and groups of users, configure group policies.

1. Access Web Config and then select the **Network Security** tab > **IPsec/IP Filtering** > **Basic**.
2. Enter a value for each item.

3. Click **Next**.  
A confirmation message is displayed.
4. Click **OK**.  
The printer is updated.

**Related Information**

➔ [“Application for Configuring Printer Operations \(Web Config\)” on page 221](#)

**Default Policy Setting Items**

**Default Policy**

Items	Settings and Explanation
IPsec/IP Filtering	You can enable or disable an IPsec/IP Filtering feature.

**Access Control**

Configure a control method for traffic of IP packets.

Items	Settings and Explanation
Permit Access	Select this to permit configured IP packets to pass through.
Refuse Access	Select this to refuse configured IP packets to pass through.
IPsec	Select this to permit configured IPsec packets to pass through.

**IKE Version**

Select **IKEv1** or **IKEv2** for **IKE Version**. Select one of them according to the device that the printer is connected to.

**IKEv1**

The following items are displayed when you select **IKEv1** for **IKE Version**.

Items	Settings and Explanation
Authentication Method	To select <b>Certificate</b> , you need to obtain and import a CA-signed certificate in advance.
Pre-Shared Key	If you select <b>Pre-Shared Key</b> for <b>Authentication Method</b> , enter a pre-shared key between 1 and 127 characters.
Confirm Pre-Shared Key	Enter the key you configured for confirmation.

**IKEv2**

The following items are displayed when you select **IKEv2** for **IKE Version**.

Items	Settings and Explanation	
Local	Authentication Method	To select <b>Certificate</b> , you need to obtain and import a CA-signed certificate in advance.
	ID Type	If you select <b>Pre-Shared Key</b> for <b>Authentication Method</b> , select the type of ID for the printer.
	ID	Enter the printer's ID that matches the type of ID. You cannot use "@", "#", and "=" for the first character. <b>Distinguished Name</b> : Enter 1 to 255 1-byte ASCII (0x20 to 0x7E) characters. You need to include "=". <b>IP Address</b> : Enter IPv4 or IPv6 format. <b>FQDN</b> : Enter a combination of between 1 and 255 characters using A-Z, a-z, 0-9, "-", and period (.). <b>Email Address</b> : Enter 1 to 255 1-byte ASCII (0x20 to 0x7E) characters. You need to include "@". <b>Key ID</b> : Enter 1 to 255 1-byte ASCII (0x20 to 0x7E) characters.
	Pre-Shared Key	If you select <b>Pre-Shared Key</b> for <b>Authentication Method</b> , enter a pre-shared key between 1 and 127 characters.
	Confirm Pre-Shared Key	Enter the key you configured for confirmation.

Items		Settings and Explanation
Remote	Authentication Method	To select <b>Certificate</b> , you need to obtain and import a CA-signed certificate in advance.
	ID Type	If you select <b>Pre-Shared Key</b> for <b>Authentication Method</b> , select the type of ID for the device that you want to authenticate.
	ID	Enter the printer's ID that matches to the type of ID. You cannot use "@", "#", and "=" for the first character. <b>Distinguished Name</b> : Enter 1 to 255 1-byte ASCII (0x20 to 0x7E) characters. You need to include "=". <b>IP Address</b> : Enter IPv4 or IPv6 format. <b>FQDN</b> : Enter a combination of between 1 and 255 characters using A-Z, a-z, 0-9, "-", and period (.). <b>Email Address</b> : Enter 1 to 255 1-byte ASCII (0x20 to 0x7E) characters. You need to include "@". <b>Key ID</b> : Enter 1 to 255 1-byte ASCII (0x20 to 0x7E) characters.
	Pre-Shared Key	If you select <b>Pre-Shared Key</b> for <b>Authentication Method</b> , enter a pre-shared key between 1 and 127 characters.
	Confirm Pre-Shared Key	Enter the key you configured for confirmation.

**Encapsulation**

If you select **IPsec** for **Access Control**, you need to configure an encapsulation mode.

Items	Settings and Explanation
Transport Mode	If you only use the printer on the same LAN, select this. IP packets of layer 4 or later are encrypted.
Tunnel Mode	If you use the printer on the Internet-capable network such as IPsec-VPN, select this option. The header and data of the IP packets are encrypted. <b>Remote Gateway(Tunnel Mode)</b> : If you select <b>Tunnel Mode</b> for <b>Encapsulation</b> , enter a gateway address between 1 and 39 characters.

**Security Protocol**

If you select **IPsec** for **Access Control**, select an option.

Items	Settings and Explanation
ESP	Select this to ensure the integrity of an authentication and data, and encrypt data.
AH	Select this to ensure the integrity of an authentication and data. Even if encrypting data is prohibited, you can use IPsec.

**❑ Algorithm Settings**

It is recommended that you select **Any** for all settings or select an item other than **Any** for each setting. If you select **Any** for some of the settings and select an item other than **Any** for the other settings, the device may not communicate depending on the other device that you want to authenticate.

Items		Settings and Explanation
IKE	Encryption	Select the encryption algorithm for IKE. The items vary depending on the version of IKE.
	Authentication	Select the authentication algorithm for IKE.
	Key Exchange	Select the key exchange algorithm for IKE. The items vary depending on the version of IKE.
ESP	Encryption	Select the encryption algorithm for ESP. This is available when <b>ESP</b> is selected for <b>Security Protocol</b> .
	Authentication	Select the authentication algorithm for ESP. This is available when <b>ESP</b> is selected for <b>Security Protocol</b> .
AH	Authentication	Select the encryption algorithm for AH. This is available when <b>AH</b> is selected for <b>Security Protocol</b> .

**Related Information**

➔ [“Configuring Default Policy” on page 268](#)

**Configuring Group Policy**

A group policy is one or more rules applied to a user or user group. The printer controls IP packets that match with configured policies. IP packets are authenticated in the order of a group policy 1 to 10 then a default policy.

1. Access Web Config and then select the **Network Security** tab > **IPsec/IP Filtering** > **Basic**.
2. Click a numbered tab you want to configure.
3. Enter a value for each item.
4. Click **Next**.  
A confirmation message is displayed.
5. Click **OK**.  
The printer is updated.

**Related Information**

➔ [“Application for Configuring Printer Operations \(Web Config\)” on page 221](#)



### Group Policy Setting Items

Items	Settings and Explanation
Enable this Group Policy	You can enable or disable a group policy.

### Access Control

Configure a control method for traffic of IP packets.

Items	Settings and Explanation
Permit Access	Select this to permit configured IP packets to pass through.
Refuse Access	Select this to refuse configured IP packets to pass through.
IPsec	Select this to permit configured IPsec packets to pass through.

### Local Address(Printer)

Select an IPv4 address or IPv6 address that matches your network environment. If an IP address is assigned automatically, you can select **Use auto-obtained IPv4 address**.

**Note:**

*If an IPv6 address is assigned automatically, the connection may be unavailable. Configure a static IPv6 address.*

### Remote Address(Host)

Enter a device's IP address to control access. The IP address must be 43 characters or less. If you do not enter an IP address, all addresses are controlled.

**Note:**

*If an IP address is assigned automatically (e.g. assigned by DHCP), the connection may be unavailable. Configure a static IP address.*

### Method of Choosing Port

Select a method to specify ports.

- Service Name

If you select **Service Name** for **Method of Choosing Port**, select an option.

- Transport Protocol

If you select **Port Number** for **Method of Choosing Port**, you need to configure an encapsulation mode.

Items	Settings and Explanation
Any Protocol	Select this to control all protocol types.
TCP	Select this to control data for unicast.
UDP	Select this to control data for broadcast and multicast.
ICMPv4	Select this to control ping command.

Local Port

If you select **Port Number** for **Method of Choosing Port** and if you select **TCP** or **UDP** for **Transport Protocol**, enter port numbers to control receiving packets, separating them with commas. You can enter 10 port numbers at the maximum.

Example: 20,80,119,5220

If you do not enter a port number, all ports are controlled.

Remote Port

If you select **Port Number** for **Method of Choosing Port** and if you select **TCP** or **UDP** for **Transport Protocol**, enter port numbers to control sending packets, separating them with commas. You can enter 10 port numbers at the maximum.

Example: 25,80,143,5220

If you do not enter a port number, all ports are controlled.

**IKE Version**

Select **IKEv1** or **IKEv2** for **IKE Version**. Select one of them according to the device that the printer is connected to.

IKEv1

The following items are displayed when you select **IKEv1** for **IKE Version**.

Items	Settings and Explanation
Authentication Method	If you select <b>IPsec</b> for <b>Access Control</b> , select an option. Used certificate is common with a default policy.
Pre-Shared Key	If you select <b>Pre-Shared Key</b> for <b>Authentication Method</b> , enter a pre-shared key between 1 and 127 characters.
Confirm Pre-Shared Key	Enter the key you configured for confirmation.

❑ IKEv2

The following items are displayed when you select **IKEv2** for **IKE Version**.

Items		Settings and Explanation
Local	Authentication Method	If you select <b>IPsec</b> for <b>Access Control</b> , select an option. Used certificate is common with a default policy.
	ID Type	If you select <b>Pre-Shared Key</b> for <b>Authentication Method</b> , select the type of ID for the printer.
	ID	Enter the printer's ID that matches the type of ID. You cannot use "@", "#", and "=" for the first character. <b>Distinguished Name</b> : Enter 1 to 255 1-byte ASCII (0x20 to 0x7E) characters. You need to include "=". <b>IP Address</b> : Enter IPv4 or IPv6 format. <b>FQDN</b> : Enter a combination of between 1 and 255 characters using A-Z, a-z, 0-9, "-", and period (.). <b>Email Address</b> : Enter 1 to 255 1-byte ASCII (0x20 to 0x7E) characters. You need to include "@". <b>Key ID</b> : Enter 1 to 255 1-byte ASCII (0x20 to 0x7E) characters.
	Pre-Shared Key	If you select <b>Pre-Shared Key</b> for <b>Authentication Method</b> , enter a pre-shared key between 1 and 127 characters.
	Confirm Pre-Shared Key	Enter the key you configured for confirmation.
Remote	Authentication Method	If you select <b>IPsec</b> for <b>Access Control</b> , select an option. Used certificate is common with a default policy.
	ID Type	If you select <b>Pre-Shared Key</b> for <b>Authentication Method</b> , select the type of ID for the device that you want to authenticate.
	ID	Enter the printer's ID that matches to the type of ID. You cannot use "@", "#", and "=" for the first character. <b>Distinguished Name</b> : Enter 1 to 255 1-byte ASCII (0x20 to 0x7E) characters. You need to include "=". <b>IP Address</b> : Enter IPv4 or IPv6 format. <b>FQDN</b> : Enter a combination of between 1 and 255 characters using A-Z, a-z, 0-9, "-", and period (.). <b>Email Address</b> : Enter 1 to 255 1-byte ASCII (0x20 to 0x7E) characters. You need to include "@". <b>Key ID</b> : Enter 1 to 255 1-byte ASCII (0x20 to 0x7E) characters.
	Pre-Shared Key	If you select <b>Pre-Shared Key</b> for <b>Authentication Method</b> , enter a pre-shared key between 1 and 127 characters.
	Confirm Pre-Shared Key	Enter the key you configured for confirmation.

**Encapsulation**

If you select **IPsec** for **Access Control**, you need to configure an encapsulation mode.

Items	Settings and Explanation
Transport Mode	If you only use the printer on the same LAN, select this. IP packets of layer 4 or later are encrypted.
Tunnel Mode	If you use the printer on the Internet-capable network such as IPsec-VPN, select this option. The header and data of the IP packets are encrypted.  <b>Remote Gateway(Tunnel Mode):</b> If you select <b>Tunnel Mode</b> for <b>Encapsulation</b> , enter a gateway address between 1 and 39 characters.

### Security Protocol

If you select **IPsec** for **Access Control**, select an option.

Items	Settings and Explanation
ESP	Select this to ensure the integrity of an authentication and data, and encrypt data.
AH	Select this to ensure the integrity of an authentication and data. Even if encrypting data is prohibited, you can use IPsec.

### Algorithm Settings

It is recommended that you select **Any** for all settings or select an item other than **Any** for each setting. If you select **Any** for some of the settings and select an item other than **Any** for the other settings, the device may not communicate depending on the other device that you want to authenticate.

Items	Settings and Explanation
IKE	Encryption Select the encryption algorithm for IKE. The items vary depending on the version of IKE.
	Authentication Select the authentication algorithm for IKE.
	Key Exchange Select the key exchange algorithm for IKE. The items vary depending on the version of IKE.
ESP	Encryption Select the encryption algorithm for ESP. This is available when <b>ESP</b> is selected for <b>Security Protocol</b> .
	Authentication Select the authentication algorithm for ESP. This is available when <b>ESP</b> is selected for <b>Security Protocol</b> .
AH	Authentication Select the encryption algorithm for AH. This is available when <b>AH</b> is selected for <b>Security Protocol</b> .

### Related Information

- ➔ [“Configuring Group Policy” on page 272](#)
- ➔ [“Combination of Local Address\(Printer\) and Remote Address\(Host\) on Group Policy” on page 277](#)
- ➔ [“References of Service Name on Group Policy” on page 277](#)

### Combination of Local Address(Printer) and Remote Address(Host) on Group Policy

		Setting of Local Address(Printer)		
		IPv4	IPv6*2	Any addresses*3
Setting of Remote Address(Host)	IPv4*1	✓	–	✓
	IPv6*1*2	–	✓	✓
	Blank	✓	✓	✓

\*1 : If IPsec is selected for **Access Control**, you cannot specify in a prefix length.

\*2 : If IPsec is selected for **Access Control**, you can select a link-local address (fe80::) but group policy will be disabled.

\*3 : Except IPv6 link local addresses.

### References of Service Name on Group Policy

**Note:**

Unavailable services are displayed but cannot be selected.

Service Name	Protocol type	Local port number	Remote port number	Features controlled
Any	–	–	–	All services
ENPC	UDP	3289	Any port	Searching for a printer from applications such as Epson Device Admin, and the printer driver
SNMP	UDP	161	Any port	Acquiring and configuring of MIB from applications such as Epson Device Admin, and the printer driver
LPR	TCP	515	Any port	Forwarding LPR data
RAW (Port9100)	TCP	9100	Any port	Forwarding RAW data
IPP/IPPS	TCP	631	Any port	Forwarding data of IPP/IPPS printing
WSD	TCP	Any port	5357	Controlling WSD
WS-Discovery	UDP	3702	Any port	Searching for a printer from WSD
FTP Data (Local)	TCP	20	Any port	FTP server (forwarding data of FTP printing)
FTP Control (Local)	TCP	21	Any port	FTP server (controlling FTP printing)
HTTP (Local)	TCP	80	Any port	HTTP(S) server (forwarding data of Web Config and WSD)
HTTPS (Local)	TCP	443	Any port	
HTTP (Remote)	TCP	Any port	80	HTTP(S) client (communicating between Epson Connect, firmware updating and root certificate updating)
HTTPS (Remote)	TCP	Any port	443	

## Configuration Examples of IPsec/IP Filtering

### Receiving IPsec packets only

This example is to configure a default policy only.

#### Default Policy:

- IPsec/IP Filtering: Enable**
- Access Control: IPsec**
- Authentication Method: Pre-Shared Key**
- Pre-Shared Key:** Enter up to 127 characters.

**Group Policy:** Do not configure.

### Receiving printing data and printer settings

This example allows communications of printing data and printer configuration from specified services.

#### Default Policy:

- IPsec/IP Filtering: Enable**
- Access Control: Refuse Access**

#### Group Policy:

- Enable this Group Policy:** Check the box.
- Access Control: Permit Access**
- Remote Address(Host):** IP address of a client
- Method of Choosing Port: Service Name**
- Service Name:** Check the box of ENPC, SNMP, HTTP (Local), HTTPS (Local) and RAW (Port9100).

#### **Note:**

To avoid receiving HTTP (Local) and HTTPS (Local), clear their checkboxes in **Group Policy**. When doing so, disable IPsec/IP filtering from the printer's control panel temporarily to change the printer settings.

### Receiving access from a specified IP address only

This example allows a specified IP address to access the printer.

#### Default Policy:

- IPsec/IP Filtering: Enable**
- Access Control: Refuse Access**

#### Group Policy:

- Enable this Group Policy:** Check the box.
- Access Control: Permit Access**
- Remote Address(Host):** IP address of an administrator's client

#### **Note:**

Regardless of policy configuration, the client will be able to access and configure the printer.

## Configuring a Certificate for IPsec/IP Filtering

Configure the Client Certificate for IPsec/IP Filtering. When you set it, you can use the certificate as an authentication method for IPsec/IP Filtering. If you want to configure the certification authority, go to **CA Certificate**.

1. Access Web Config and then select the **Network Security** tab > **IPsec/IP Filtering** > **Client Certificate**.
2. Import the certificate in **Client Certificate**.

If you have already imported a certificate published by a Certification Authority, you can copy the certificate and use it in IPsec/IP Filtering. To copy, select the certificate from **Copy From**, and then click **Copy**.

### Related Information

- ➔ [“Application for Configuring Printer Operations \(Web Config\)” on page 221](#)
- ➔ [“Configuring a CA-signed Certificate” on page 262](#)
- ➔ [“Configuring a CA Certificate” on page 266](#)

## Connecting the Printer to an IEEE802.1X Network

### Configuring an IEEE802.1X Network

When you set IEEE802.1X to the printer, you can use it on the network connected to a RADIUS server, a LAN switch with authentication function, or an access point.

1. Access Web Config and then select the **Network Security** tab > **IEEE802.1X** > **Basic**.
2. Enter a value for each item.
3. Click **Next**.  
A confirmation message is displayed.
4. Click **OK**.  
The printer is updated.

### Related Information

- ➔ [“Application for Configuring Printer Operations \(Web Config\)” on page 221](#)

### IEEE802.1X Network Setting Items

Items	Settings and Explanation
IEEE802.1X (Wired LAN)	You can enable or disable settings of the page ( <b>IEEE802.1X</b> > <b>Basic</b> ) for IEEE802.1X (Wired LAN).

Items	Settings and Explanation	
EAP Type	Select an option for an authentication method between the printer and a RADIUS server.	
	EAP-TLS	You need to obtain and import a CA-signed certificate.
	PEAP-TLS	
	EAP-TTLS	You need to configure a password.
	PEAP/MSCHAPv2	
User ID	Configure an ID to use for an authentication of a RADIUS server. Enter 1 to 128 1-byte ASCII (0x20 to 0x7E) characters.	
Password	Configure a password to authenticate the printer. Enter 1 to 128 1-byte ASCII (0x20 to 0x7E) characters. If you are using a Windows server as a RADIUS server, you can enter up to 127 characters.	
Confirm Password	Enter the password you configured for confirmation.	
Server ID	You can configure a server ID to authenticate with a specified RADIUS server. Authenticator verifies whether a server ID is contained in the subject/subjectAltName field of a server certificate that is sent from a RADIUS server or not. Enter 0 to 128 1-byte ASCII (0x20 to 0x7E) characters.	
Certificate Validation	You can set certificate validation regardless of the authentication method. Import the certificate in <b>CA Certificate</b> .	
Anonymous Name	If you select <b>PEAP-TLS</b> , <b>EAP-TTLS</b> or <b>PEAP/MSCHAPv2</b> for <b>EAP Type</b> , you can configure an anonymous name instead of a user ID for a phase 1 of a PEAP authentication. Enter 0 to 128 1-byte ASCII (0x20 to 0x7E) characters.	
Encryption Strength	You can select one of the followings.	
	High	AES256/3DES
	Middle	AES256/3DES/AES128/RC4

### Related Information

➔ [“Configuring an IEEE802.1X Network” on page 279](#)

## Configuring a Certificate for IEEE802.1X

Configure the Client Certificate for IEEE802.1X. When you set it, you can use **EAP-TLS** and **PEAP-TLS** as an authentication method of IEEE802.1x. If you want to configure the certification authority certificate, go to **CA Certificate**.

1. Access Web Config and then select the **Network Security** tab > **IEEE802.1X** > **Client Certificate**.
2. Enter a certificate in the **Client Certificate**.

If you have already imported a certificate published by a Certification Authority, you can copy the certificate and use it in IEEE802.1X. To copy, select the certificate from **Copy From**, and then click **Copy**.



### Related Information

- ➔ [“Application for Configuring Printer Operations \(Web Config\)” on page 221](#)
- ➔ [“Configuring a CA-signed Certificate” on page 262](#)
- ➔ [“Configuring a CA Certificate” on page 266](#)

## Checking IEEE802.1X Network Status

You can check the IEEE802.1X status by printing a network status sheet.

Status ID	IEEE802.1X Status
Disable	IEEE802.1X feature is disable.
EAP Success	IEEE802.1X authentication has succeeded and network connection is available.
Authenticating	IEEE802.1X authentication has not been completed.
Config Error	Authentication has failed since the user ID has not been set.
Client Certificate Error	Authentication has failed since the client certificate is out of date.
Timeout Error	Authentication has failed since there is no answer from the RADIUS server and/or authenticator.
User ID Error	Authentication has failed since the printer's user ID and/or certificate protocol is incorrect.
Server ID Error	Authentication has failed since the server ID of the server certificate and the server's ID do not match.
Server Certificate Error	Authentication has failed since there are the following errors in the server certificate. <ul style="list-style-type: none"> <li><input type="checkbox"/> The server certificate is out of date.</li> <li><input type="checkbox"/> The chain of the server certificate is incorrect.</li> </ul>
CA Certificate Error	Authentication has failed since there are the following errors in a CA certificate. <ul style="list-style-type: none"> <li><input type="checkbox"/> Specified CA certificate is incorrect.</li> <li><input type="checkbox"/> The correct CA certificate is not imported.</li> <li><input type="checkbox"/> CA certificate is out of date.</li> </ul>
EAP Failure	Authentication has failed since there are the following errors in the printer settings. <ul style="list-style-type: none"> <li><input type="checkbox"/> If <b>EAP Type</b> is <b>EAP-TLS</b> or <b>PEAP-TLS</b>, client certificate is incorrect or has certain problems.</li> <li><input type="checkbox"/> If <b>EAP Type</b> is <b>EAP-TTLS</b> or <b>PEAP/MSCHAPv2</b>, user ID or password is not correct.</li> </ul>

### Related Information

- ➔ [“Printing a Network Status Sheet” on page 142](#)

## Solving Problems for Advanced Security

### Restoring the Security Settings

When you establish a highly secure environment such as IPsec/IP Filtering or IEEE802.1X, you may not be able to communicate with devices because of incorrect settings or trouble with the device or server. In this case, restore the security settings in order to make settings for the device again or to allow you temporary use.

#### ***Disabling the Security Function Using the Control Panel***

You can disable IPsec/IP Filtering or IEEE802.1X using the printer's control panel.

1. Select **Settings > General Settings > Network Settings**.
2. Select **Advanced**.
3. Select from the following items that you want to disable.
  - Disable IPsec/IP Filtering**
  - Disable IEEE802.1X**
4. Select **Proceed** on the confirmation screen.

### Problems Using Network Security Features

#### ***Forgot a Pre-shared Key***

##### **Re-configure a pre-shared key.**

To change the key, access Web Config and select the **Network Security** tab > **IPsec/IP Filtering** > **Basic** > **Default Policy** or **Group Policy**.

When you change the pre-shared key, configure the pre-shared key for computers.

#### **Related Information**

- ➔ [“Application for Configuring Printer Operations \(Web Config\)” on page 221](#)
- ➔ [“Encrypted Communication Using IPsec/IP Filtering” on page 268](#)

#### ***Cannot Communicate with IPsec Communication***

##### **Specify the algorithm that the printer or the computer does not support.**

The printer supports the following algorithms. Check the settings of the computer.

Security Methods	Algorithms
IKE encryption algorithm	AES-CBC-128, AES-CBC-192, AES-CBC-256, AES-GCM-128*, AES-GCM-192*, AES-GCM-256*, 3DES
IKE authentication algorithm	SHA-1, SHA-256, SHA-384, SHA-512, MD5
IKE key exchange algorithm	DH Group1, DH Group2, DH Group5, DH Group14, DH Group15, DH Group16, DH Group17, DH Group18, DH Group19, DH Group20, DH Group21, DH Group22, DH Group23, DH Group24, DH Group25, DH Group26, DH Group27*, DH Group28*, DH Group29*, DH Group30*
ESP encryption algorithm	AES-CBC-128, AES-CBC-192, AES-CBC-256, AES-GCM-128, AES-GCM-192, AES-GCM-256, 3DES
ESP authentication algorithm	SHA-1, SHA-256, SHA-384, SHA-512, MD5
AH authentication algorithm	SHA-1, SHA-256, SHA-384, SHA-512, MD5

\*available for IKEv2 only

### Related Information

➔ [“Encrypted Communication Using IPsec/IP Filtering” on page 268](#)

### Cannot Communicate Suddenly

#### The IP address of the printer has been changed or cannot be used.

When the IP address registered to the local address on Group Policy has been changed or cannot be used, IPsec communication cannot be performed. Disable IPsec using the printer's control panel.

If the DHCP is out of date, rebooting or the IPv6 address is out of date or has not been obtained, then the IP address registered for the printer's Web Config (**Network Security** tab > **IPsec/IP Filtering** > **Basic** > **Group Policy** > **Local Address(Printer)**) may not be found.

Use a static IP address.

#### The IP address of the computer has been changed or cannot be used.

When the IP address registered to the remote address on Group Policy has been changed or cannot be used, IPsec communication cannot be performed.

Disable IPsec using the printer's control panel.

If the DHCP is out of date, rebooting or the IPv6 address is out of date or has not been obtained, then the IP address registered for the printer's Web Config (**Network Security** tab > **IPsec/IP Filtering** > **Basic** > **Group Policy** > **Remote Address(Host)**) may not be found.

Use a static IP address.

### Related Information

➔ [“Application for Configuring Printer Operations \(Web Config\)” on page 221](#)

➔ [“Encrypted Communication Using IPsec/IP Filtering” on page 268](#)

### ***Cannot Create the Secure IPP Printing Port***

#### **The correct certificate is not specified as the server certificate for SSL/TLS communication.**

If the specified certificate is not correct, creating a port may fail. Make sure you are using the correct certificate.

#### **The CA certificate is not imported to the computer accessing the printer.**

If a CA certificate is not imported to the computer, creating a port may fail. Make sure a CA certificate is imported.

#### **Related Information**

➔ [“Configuring a Server Certificate for the Printer” on page 268](#)

### ***Cannot Connect After Configuring IPsec/IP Filtering***

#### **The settings of IPsec/IP Filtering are incorrect.**

Disable IPsec/IP filtering from the printer’s control panel. Connect the printer and computer and make the IPsec/IP Filtering settings again.

#### **Related Information**

➔ [“Encrypted Communication Using IPsec/IP Filtering” on page 268](#)

### ***Cannot Access the Printer after Configuring IEEE802.1X***

#### **The settings of IEEE802.1X are incorrect.**

Disable IEEE802.1X from the printer’s control panel. Connect the printer and a computer, and then configure IEEE802.1X again.

#### **Related Information**

➔ [“Configuring an IEEE802.1X Network” on page 279](#)

## **Problems on Using a Digital Certificate**

### ***Cannot Import a CA-signed Certificate***

#### **CA-signed Certificate and the information on the CSR do not match.**

If the CA-signed Certificate and CSR do not have the same information, the CSR cannot be imported. Check the following:

- Are you trying to import the certificate to a device that does not have the same information?  
Check the information of the CSR and then import the certificate to a device that has the same information.
- Did you overwrite the CSR saved into the printer after sending the CSR to a certificate authority?  
Obtain the CA-signed certificate again with the CSR.

**CA-signed Certificate is more than 5KB.**

You cannot import a CA-signed Certificate that is more than 5KB.

**The password for importing the certificate is incorrect.**

Enter the correct password. If you forget the password, you cannot import the certificate. Re-obtain the CA-signed Certificate.

**Related Information**

➔ [“Importing a CA-signed Certificate” on page 264](#)

***Cannot Update a Self-Signed Certificate***

**The Common Name has not been entered.**

**Common Name** must be entered.

**Unsupported characters have been entered to Common Name.**

Enter between 1 and 128 characters of either IPv4, IPv6, host name, or FQDN format in ASCII (0x20-0x7E).

**A comma or space is included in the common name.**

If a comma is entered, the **Common Name** is divided at that point. If only a space is entered before or after a comma, an error occurs.

**Related Information**

➔ [“Updating a Self-signed Certificate” on page 265](#)

***Cannot Create a CSR***

**The Common Name has not been entered.**

The **Common Name** must be entered.

**Unsupported characters have been entered to Common Name, Organization, Organizational Unit, Locality, and State/Province.**

Enter characters of either IPv4, IPv6, host name, or FQDN format in ASCII (0x20-0x7E).

**A comma or space is included in the Common Name.**

If a comma is entered, the **Common Name** is divided at that point. If only a space is entered before or after a comma, an error occurs.

**Related Information**

➔ [“Obtaining a CA-signed Certificate” on page 262](#)

**Warning Relating to a Digital Certificate Appears**

Messages	Cause/What to do
Enter a Server Certificate.	<p><b>Cause:</b> You have not selected a file to import.</p> <p><b>What to do:</b> Select a file and click <b>Import</b>.</p>
CA Certificate 1 is not entered.	<p><b>Cause:</b> CA certificate 1 is not entered and only CA certificate 2 is entered.</p> <p><b>What to do:</b> Import CA certificate 1 first.</p>
Invalid value below.	<p><b>Cause:</b> Unsupported characters are contained in the file path and/or password.</p> <p><b>What to do:</b> Make sure that the characters are entered correctly for the item.</p>
Invalid date and time.	<p><b>Cause:</b> Date and time for the printer have not been set.</p> <p><b>What to do:</b> Set date and time using Web Config, EpsonNet Config or the printer's control panel.</p>
Invalid password.	<p><b>Cause:</b> The password set for CA certificate and entered password do not match.</p> <p><b>What to do:</b> Enter the correct password.</p>
Invalid file.	<p><b>Cause:</b> You are not importing a certificate file in X509 format.</p> <p><b>What to do:</b> Make sure that you are selecting the correct certificate sent by a trusted certificate authority.</p>
	<p><b>Cause:</b> The file you have imported is too large. The maximum file size is 5KB.</p> <p><b>What to do:</b> If you select the correct file, the certificate might be corrupted or fabricated.</p>
	<p><b>Cause:</b> The chain contained in the certificate is invalid.</p> <p><b>What to do:</b> For more information on the certificate, see the website of the certificate authority.</p>

Messages	Cause/What to do
Cannot use the Server Certificates that include more than three CA certificates.	<p><b>Cause:</b> The certificate file in PKCS#12 format contains more than 3 CA certificates.</p> <p><b>What to do:</b> Import each certificate as converting from PKCS#12 format to PEM format, or import the certificate file in PKCS#12 format that contains up to 2 CA certificates.</p>
The certificate has expired. Check if the certificate is valid, or check the date and time on your printer.	<p><b>Cause:</b> The certificate is out of date.</p> <p><b>What to do:</b></p> <ul style="list-style-type: none"> <li><input type="checkbox"/> If the certificate is out of date, obtain and import the new certificate.</li> <li><input type="checkbox"/> If the certificate is not out of date, make sure the printer's date and time are set correctly.</li> </ul>
Private key is required.	<p><b>Cause:</b> There is no paired private key with the certificate.</p> <p><b>What to do:</b></p> <ul style="list-style-type: none"> <li><input type="checkbox"/> If the certificate is the PEM/DER format and it is obtained from a CSR using a computer, specify the private key file.</li> <li><input type="checkbox"/> If the certificate is the PKCS#12 format and it is obtained from a CSR using a computer, create a file that contains the private key.</li> </ul>
	<p><b>Cause:</b> You have re-imported the PEM/DER certificate obtained from a CSR using Web Config.</p> <p><b>What to do:</b> If the certificate is the PEM/DER format and it is obtained from a CSR using Web Config, you can only import it once.</p>
Setup failed.	<p><b>Cause:</b> Cannot finish the configuration because the communication between the printer and computer failed or the file cannot be read by some errors.</p> <p><b>What to do:</b> After checking the specified file and communication, import the file again.</p>

### Related Information

➔ [“About Digital Certification” on page 261](#)

### Delete a CA-signed Certificate by Mistake

#### There is no backup file for the CA-signed certificate.

If you have the backup file, import the certificate again.

If you obtain a certificate using a CSR created from Web Config, you cannot import a deleted certificate again. Create a CSR and obtain a new certificate.

**Related Information**

- ➔ [“Importing a CA-signed Certificate” on page 264](#)
- ➔ [“Deleting a CA-signed Certificate” on page 265](#)

---

## **Epson Remote Services Information**

Epson Remote Services is a service that periodically collects printer information over the Internet. This can be used to predict when consumables and replacement parts need to be replaced or replenished, and to quickly resolve any errors or problems.

Contact your sales representative for more information about Epson Remote Services.



---

# Where to Get Help

Technical Support Web Site. . . . .	290
Contacting Epson Support. . . . .	290

---

## Technical Support Web Site

If you need further help, visit the Epson support website shown below. Select your country or region and go to the support section of your local Epson website. The latest drivers, FAQs, manuals, or other downloadables are also available from the site.

<http://support.epson.net/>

<http://www.epson.eu/support> (Europe)

If your Epson product is not operating properly and you cannot solve the problem, contact Epson support services for assistance.

---

## Contacting Epson Support

### Before Contacting Epson

If your Epson product is not operating properly and you cannot solve the problem using the troubleshooting information in your product manuals, contact Epson support services for assistance.

The following Epson support list is based on the country of sale. Some products may not be sold in your current location, so be sure to contact Epson support for the area in which you purchased your product.

If Epson support for your area is not listed below, contact the dealer where you purchased your product.

Epson support will be able to help you much more quickly if you give them the following information:

- Product serial number  
(The serial number label is on the front of the printer and can be viewed when you open the paper tray.)
- Product model
- Product software version  
(Click **About**, **Version Info**, or a similar button in the product software.)
- Brand and model of your computer
- Your computer operating system name and version
- Names and versions of the software applications you normally use with your product

**Note:**

*Depending on the product, network settings may be stored in the product's memory. Due to breakdown or repair of a product, settings may be lost. Epson shall not be responsible for the loss of any data, for backing up or recovering settings even during a warranty period. We recommend that you make your own backup data or take notes.*

### Help for Users in Taiwan

Contacts for information, support, and services are:

#### World Wide Web

<http://www.epson.com.tw>

Information on product specifications, drivers for download, and products enquiry are available.

### **Epson HelpDesk**

Phone: +886-2-80242008

Our HelpDesk team can help you with the following over the phone:

- Sales enquiries and product information
- Product usage questions or problems
- Enquiries on repair service and warranty

### **Repair service center:**

<http://www.tekcare.com.tw/branchMap.page>

TekCare corporation is an authorized service center for Epson Taiwan Technology & Trading Ltd.

## **Help for Users in Singapore**

Sources of information, support, and services available from Epson Singapore are:

### **World Wide Web**

<http://www.epson.com.sg>

Information on product specifications, drivers for download, Frequently Asked Questions (FAQ), Sales Enquiries, and Technical Support via e-mail are available.

### **Epson HelpDesk**

Toll Free: 800-120-5564

Our HelpDesk team can help you with the following over the phone:

- Sales enquiries and product information
- Product usage questions or problem troubleshooting
- Enquiries on repair service and warranty

## **Help for Users in Thailand**

Contacts for information, support, and services are:

### **World Wide Web**

<http://www.epson.co.th>

Information on product specifications, drivers for download, Frequently Asked Questions (FAQ), and e-mail are available.

### **Epson Call Centre**

Phone: 66-2685-9899

Email: [support@eth.epson.co.th](mailto:support@eth.epson.co.th)

Our Call Centre team can help you with the following over the phone:

- Sales enquiries and product information

- Product usage questions or problems
- Enquiries on repair service and warranty

## Help for Users in Indonesia

Contacts for information, support, and services are:

### World Wide Web

<http://www.epson.co.id>

- Information on product specifications, drivers for download
- Frequently Asked Questions (FAQ), Sales Enquiries, questions through e-mail

### Epson Hotline

Phone: +62-1500-766

Fax: +62-21-808-66-799

Our Hotline team can help you with the following over the phone or fax:

- Sales enquiries and product information
- Technical support

### Epson Service Center

Province	Company Name	Address	Phone E-mail
JAKARTA	Epson Sales and Service Jakarta (SUDIRMAN)	Wisma Keiai Lt. 1 Jl. Jenderal Sudirman Kav. 3 Jakarta Pusat - DKI JAKARTA 10220	021-5724335 ess@epson-indonesia.co.id; ess.support@epson-indonesia.co.id
SERPONG	Epson Sales and Service Serpong	Ruko Melati Mas Square Blok A2 No.17 Serpong-Banten	082120090084 / 082120090085 esstag@epson-indonesia.co.id; esstag.support@epson-indonesia.co.id
SEMARANG	Epson Sales and Service Semarang	Komplek Ruko Metro Plaza Block C20 Jl. MT Haryono No. 970 Semarang -JAWA TENGAH	024 8313807 / 024 8417935 esssmg@epson-indonesia.co.id; esssmg.support@epson-indonesia.co.id
JAKARTA	Epson Sales and Service Jakarta (MANGGA DUA)	Ruko Mall Mangga Dua No. 48 Jl. Arteri Mangga Dua, Jakarta Utara - DKI JAKARTA	021 623 01104 jkt-technical1@epson-indonesia.co.id; jkt-admin@epson-indonesia.co.id
BANDUNG	Epson Sales and Service Bandung	Jl. Cihampelas No. 48 A Bandung Jawa Barat 40116	022 420 7033 bdg-technical@epson-indonesia.co.id; bdg-admin@epson-indonesia.co.id

Province	Company Name	Address	Phone E-mail
MAKASSAR	Epson Sales and Service Makassar	Jl. Cendrawasih NO. 3A, kunjung mae, mariso, MAKASSAR - SULSEL 90125	0411- 8911071 mksr-technical@epson-indonesia.co.id; mksr-admin@epson-indonesia.co.id
MEDAN	Epson Service Center Medan	Jl. Bambu 2 Komplek Graha Niaga Nomor A-4, Medan - SUMUT	061- 42066090 / 42066091 mdn-technical@epson-indonesia.co.id; mdn-adm@epson-indonesia.co.id
PALEMBANG	Epson Service Center Palembang	Jl. H.M Rasyid Nawawi No. 249 Kelurahan 9 Ilir Palembang Sumatera Selatan	0711 311 330 escplg@epson-indonesia.co.id; escplg.support@epson-indonesia.co.id
PEKANBARU	Epson Service Center Pekanbaru	Jl. Tuanku Tambusai No. 459 A Kel. Tangkerang barat Kec Marpoyan damai Pekanbaru - Riau 28282	0761- 8524695 pkb-technical@epson-indonesia.co.id; pkb-admin@epson-indonesia.co.id
PONTIANAK	Epson Service Center Pontianak	Komp. A yani Sentra Bisnis G33, Jl. Ahmad Yani - Pontianak Kalimantan Barat	0561- 735507 / 767049 pontianak-technical@epson-indonesia.co.id; pontianak-admin@epson-indonesia.co.id
SAMARINDA	Epson Service Center Samarinda	Jl. KH. Wahid Hasyim (M. Yamin) Kelurahan Sempaja Selatan Kecamatan Samarinda UTARA - SAMARINDA - KALTIM	0541 7272 904 escsmd@epson-indonesia.co.id; escsmd.support@epson-indonesia.co.id
SURABAYA	Epson Sales & Service Surabaya (barat)	Jl. Haji Abdul Wahab Saimin, Ruko Villa Bukit Mas RM-11, Kec. Dukuh Pakis, Surabaya - 60225	031- 5120994 sby-technical@epson-indonesia.co.id; sby-admin@epson-indonesia.co.id
YOGYAKARTA	Epson Service Center Yogyakarta	YAP Square, Block A No. 6 Jl. C Simanjutak Yogyakarta - DIY	0274 581 065 ygy-technical@epson-indonesia.co.id; ygy-admin@epson-indonesia.co.id
JEMBER	Epson Service Center Jember	JL. Panglima Besar Sudirman Ruko no.1D Jember-Jawa Timur (Depan Balai Penelitian & Pengolahan Kakao)	0331- 488373 / 486468 jmr-admin@epson-indonesia.co.id; jmr-technical@epson-indonesia.co.id
MANADO	EPSON SALES AND SERVICE Manado	Jl. Piere Tendean Blok D No 4 Kawasan Mega Mas Boulevard - Manado 95111	0431- 8805896 MND-ADMIN@EPSON-INDONESIA.CO.ID; MND-TECHNICAL@EPSON-INDONESIA.CO.ID
CIREBON	EPSON SERVICE CENTER Cirebon	Jl. Tuparev No. 04 ( Depan Hotel Apita ) Cirebon, JAWA BARAT	0231– 8800846 cbn-technical@epson-indonesia.co.id

Province	Company Name	Address	Phone E-mail
CIKARANG	EPSON SALES AND SERVICE CIKARANG	Ruko Metro Boulevard B1 Jababeka cikarang - Jawa Barat,	021- 89844301 / 29082424 ckg-admin@epson-indonesia.co.id; ckg-technical@epson-indonesia.co.id
MADIUN	EPSON SERVICE CENTER MADIUN	Jl. Diponegoro No.56, MADIUN - JAWA TIMUR	0351- 4770248 mun-admin@epson-indonesia.co.id ; mun-technical@epson-indonesia.co.id
PURWOKERTO	EPSON SALES AND SERVICE Purwokerto	Jl. Jendral Sudirman No. 4 Kranji Purwokerto - JAWA TENGAH	0281- 6512213 pwt-admin@epson-indonesia.co.id ; pwt-technical@epson-indonesia.co.id
BOGOR	EPSON SALES AND SERVICE Bogor	Jl.Pajajaran No 15B Kel Bantarjati Kec Bogor Utara - JAWA BARAT 16153	0251- 8310026 bgr-admin@epson-indonesia.co.id ; bgr-technical@epson-indonesia.co.id
SERANG	EPSON SERVICE CENTER Serang	Jl. Ahmad Yani No.45C, SERANG - BANTEN	0254- 7912503 srg-admin@epson-indonesia.co.id ; srg-technical@epson-indonesia.co.id
PALU	EPSON SALES AND SERVICE Palu	Jl. Juanda No. 58, Palu - Sulteng	0451- 4012 881 plw-admin@epson-indonesia.co.id; plw-technical@epson-indonesia.co.id
BANJARMASIN	EPSON SERVICE CENTER BANJARMASIN	Jl. Gatot Soebroto NO. 153 BANJARMASIN - KALSEL 70235	0511- 6744135 (TEKNISI) / 3266321 (ADMIN) bdj-admin@epson-indonesia.co.id; bdj-technical@epson-indonesia.co.id
DENPASAR	EPSON SALES AND SERVICE Denpasar	JL. MAHENDRADATA NO. 18, DENPASAR - BALI	0361- 3446699 / 9348428 dps-admin@epson-indonesia.co.id; dps-technical@epson-indonesia.co.id
JAKARTA	EPSON SALES AND SERVICE CILANDAK	CIBIS Business Park Tower 9 LT. MEZZANINE, Jalan TB Simatupang No.2, Jakarta Selatan - DKI JAKARTA 12560	021- 80866777 esscibis.support1@epson-indonesia.co.id; esscibis.support2@epson-indonesia.co.id; esscibis.admin@epson-indonesia.co.id; esscibis.sales@epson-indonesia.co.id

Province	Company Name	Address	Phone E-mail
SURABAYA	EPSON SALES AND SERVICE SURABAYA (GUBENG)	JL. RAYA GUBENG NO. 62, SURABAYA - JAWA TIMUR	031- 99444940 / 99446299 / 99446377 esssby@epson-indonesia.co.id; esssby.support@epson-indonesia.co.id
AMBON	EPSON SERVICE CENTER AMBON	Jl. Diponegoro No.37 (Samping Bank Mandiri Syariah) Kel.Ahusen, Kec.Sirimau - Ambon 97127	-

For other cities not listed here, call the Hot Line: 08071137766.

## Help for Users in Hong Kong

To obtain technical support as well as other after-sales services, users are welcome to contact Epson Hong Kong Limited.

### Internet Home Page

<http://www.epson.com.hk>

Epson Hong Kong has established a local home page in both Chinese and English on the Internet to provide users with the following information:

- Product information
- Answers to Frequently Asked Questions (FAQs)
- Latest versions of Epson product drivers

### Technical Support Hotline

You can also contact our technical staff at the following telephone and fax numbers:

Phone: 852-2827-8911

Fax: 852-2827-4383

## Help for Users in Malaysia

Contacts for information, support, and services are:

### World Wide Web

<http://www.epson.com.my>

- Information on product specifications, drivers for download
- Frequently Asked Questions (FAQ), Sales Enquiries, questions through e-mail

### Epson Call Centre

Phone: 1800-81-7349 (Toll Free)

Email: [websupport@emsb.epson.com.my](mailto:websupport@emsb.epson.com.my)

- Sales enquiries and product information
- Product usage questions or problems
- Enquiries on repair services and warranty

### **Head Office**

Phone: 603-56288288

Fax: 603-5628 8388/603-5621 2088

## **Help for Users in the Philippines**

To obtain technical support as well as other after sales services, users are welcome to contact the Epson Philippines Corporation at the telephone, fax numbers and e-mail address below:

### **World Wide Web**

<http://www.epson.com.ph>

Information on product specifications, drivers for download, Frequently Asked Questions (FAQ), and E-mail Enquiries are available.

### **Epson Philippines Customer Care**

Toll Free: (PLDT) 1-800-1069-37766

Toll Free: (Digital) 1-800-3-0037766

Metro Manila: (632) 8441 9030

Web Site: <https://www.epson.com.ph/contact>

E-mail: [customercare@epc.epson.com.ph](mailto:customercare@epc.epson.com.ph)

Accessible 9am to 6pm, Monday through Saturday (Except public holidays)

Our Customer Care team can help you with the following over the phone:

- Sales enquiries and product information
- Product usage questions or problems
- Enquiries on repair service and warranty

### **Epson Philippines Corporation**

Trunk Line: +632-706-2609

Fax: +632-706-2663



## Free Manuals Download Website

<http://myh66.com>

<http://usermanuals.us>

<http://www.somanuals.com>

<http://www.4manuals.cc>

<http://www.manual-lib.com>

<http://www.404manual.com>

<http://www.luxmanual.com>

<http://aubethermostatmanual.com>

Golf course search by state

<http://golfingnear.com>

Email search by domain

<http://emailbydomain.com>

Auto manuals search

<http://auto.somanuals.com>

TV manuals search

<http://tv.somanuals.com>