

EB-735Fi
EB-725Wi
ELPMB62
ELPFT01
ELPMB63

Installation Guide

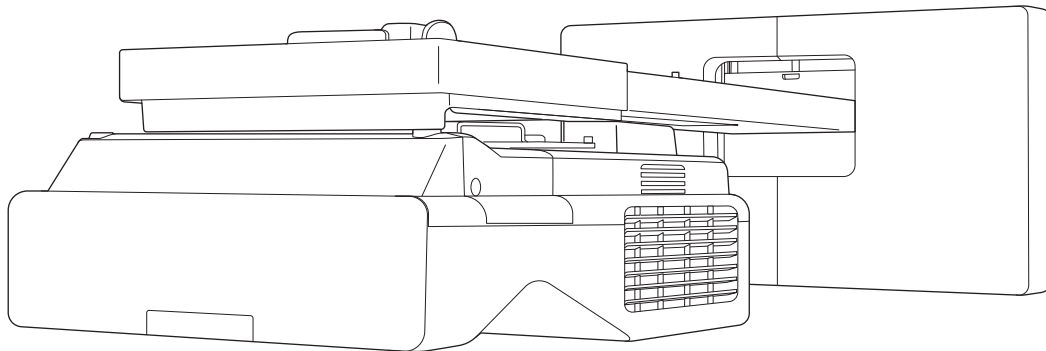

Contents of this Guide

This guide contains the following information.

- Installing an ultra-short throw projector (EB-735Fi/EB-725Wi) using the wall mount (ELPMB62)
- Installing the Touch Unit (ELPFT01)
- Installing the Touch Unit using the touch unit bracket (ELPMB63)
- Installing the Pen Stand

Equipment and mounts/brackets that are not included can be purchased as optional accessories.

About Replacement Installations

You can replace the currently installed projector with EB-735Fi/EB-725Wi, and then project images at the same size in the same position.

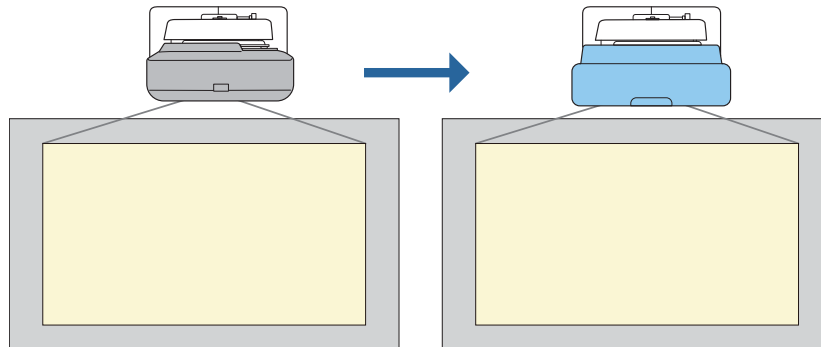

Conditions for Replacement Installations

When replacing the projector, check if the following conditions are met.

- The installed projector is one of the following:
 - BrightLink 485Wi
 - BrightLink 485Wi+
 - BrightLink 475Wi
 - BrightLink 475Wi+
 - BrightLink 480i
 - PowerLite 485W
 - PowerLite 475W
 - BrightLink 595Wi
 - BrightLink 595Wi+
 - BrightLink 585Wi
 - BrightLink 585Wi+
 - BrightLink 575Wi
 - BrightLink 575Wi+
 - BrightLink 695Wi
 - BrightLink 695Wi+
 - BrightLink 685Wi
 - BrightLink 685Wi+
 - BrightLink 680Wi
 - BrightLink 675Wi
 - BrightLink 675Wi+
 - PowerLite 470
 - PowerLite 480
 - EB-485Wi
 - EB-485Wie
 - EB-475Wi
 - EB-475Wie
 - PowerLite 585W
 - PowerLite 575W
 - PowerLite 580
 - PowerLite 570
 - PowerLite 685W
 - PowerLite 675W
 - PowerLite 680
 - PowerLite 670
 - EB-485W
 - EB-485We
 - EB-475W
 - EB-475We
 - EB-595Wi
 - EB-595Wie
 - EB-585Wi
 - EB-575Wi
 - EB-575Wie
 - EB-695Wi
 - EB-695Wie
 - EB-685Wi
 - EB-680Wi
 - EB-675Wi
 - EB-470
 - EB-480
 - EB-480e
 - EB-480i
 - EB-470i
 - EB-585W
 - EB-585We
 - EB-575W
 - EB-575We
 - EB-580
 - EB-580e
 - EB-570
 - EB-685W
 - EB-675W
 - EB-680
 - EB-680e
 - EB-670
- The installed wall mount is one of the following:
 - ELPMB28
 - ELPMB43
 - ELPMB46
- Projecting at a size of 65 to 100 inches
- Projectors have the same resolution

Example Workflow for Replacement Installations

You can replace the projector using the following workflow. The mount or your projector may differ from the illustrations. For details on handling and adjusting the mount, see the *Installation Guide* for the projector that has already been installed or for the wall mount.

- 1** Remove the old projector
 - Remove the end cap (also remove the wall plate cover if necessary)
 - Remove the adjustment unit from the setting plate
- 2** Install the new projector
 - Remove the adjustment unit from the old projector and attach it to the new projector
 - Attach the adjustment unit to the setting plate
- 3** Fine-tune the image

While projecting an image, fine-tune the position of the image using the adjustment dial on the mount and the projector's correction features
- 4** Attach the end cap

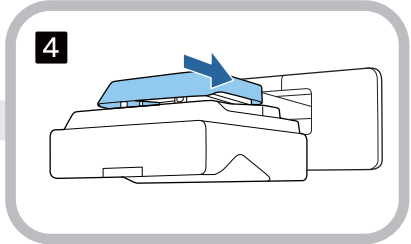
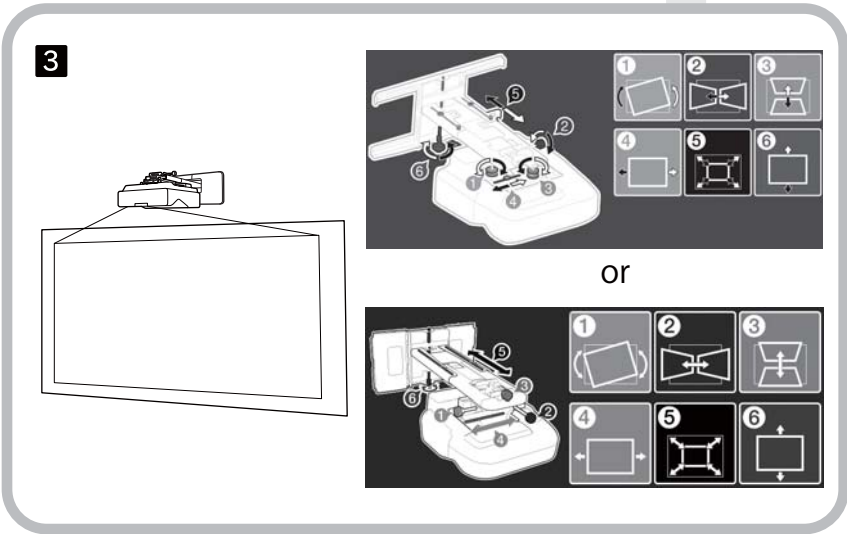
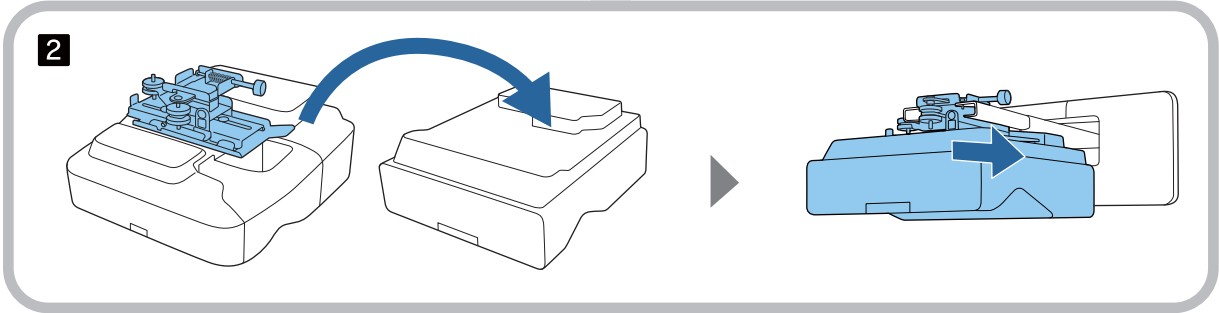
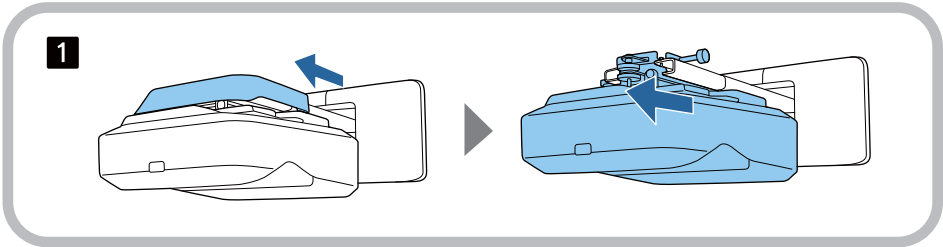

About This Installation Guide

Contents of this Guide 1

About Replacement Installations 2

Conditions for Replacement Installations 2

Example Workflow for Replacement Installations
..... 3

Introduction

Using the Product Safely 6

Safety Indications 6

Explanation of Symbols 6

Package Contents 7

Wall Mount 7

Main Mount 7

Accessories 8

Touch Unit 9

Touch Unit Bracket 10

Pen Stand 10

Necessary Items 10

Installation Work Flow 12

Figures of Installation Dimensions 13

Connection Figure 15

Connecting Multiple Projectors 15

Installing the Wall mount

Cautions on Installing the Wall Mount
..... 16

**Cautions on the Installation Location of
the Wall Mount** 19

Wall Mount Specifications 21

External Dimensions 22

Adjustment Range 24

Vertical slide 24

Horizontal slide 25

Forward/backward slide 25

Mini PC Installation Plate 26

Installing Accessories 26

**Installation Procedure for the Wall
Mount** 27

Attaching the Mount 28

Determining the installation position
(projection distance tables) 28

EB-735Fi 30

EB-725Wi 38

Attaching the adjustment unit to the
projector 43

Install the wall plate on the wall 44

Attaching the setting plate to the wall plate
..... 46

Attaching the adjustment unit to the setting
plate 51

Attaching peripheral devices 52

Adjusting the Position of the Projected Image
..... 55

Preparations before adjusting 56

Auto Screen Adjustment 58

Performing mechanical adjustment using
the Setting Plate Installation Guide 62

Adjusting using the projector menus 65

Attaching the Covers 71

Attaching a Security Cable 72

Installing the pen stand

Notes on the Pen Stand 74

Pen Stand Specifications 75

External Dimensions 75

Installing the Pen Stand 76

When Securing with Magnets 76

When Securing with Screws 77

Adjusting the Interactive Pen

Calibrating the Interactive Pen 79

Manual Calibration 79

Auto Calibration 81

Installing the Touch Unit

Notes on Handling the Touch Unit 83

For Canadian Users 84

Touch Unit Installation Location 85

Notes on the Touch Unit Bracket 86

Notes on the Laser **87**

 Attached Labels 87

 Laser Diffusion Port 87

Touch Unit Specifications **89**

 External Dimensions 89

Touch Unit Bracket Specifications **90**

 External Dimensions 90

 Adjustment Range 91

When Using an Older Model of Touch Unit **92**

Installing the Touch Unit **93**

 Installing the Infrared Deflectors 93

 Installing the Touch Unit 94

 When installing on the projection surface without using the Touch Unit Bracket 94

 When using the Touch Unit Bracket to install outside of the projection surface 97

 Attaching a Security Cable 102

 Turning on the Touch Unit 103

 Adjusting the Angle of the Laser (Touch Unit Auto Setup) 104

 When auto adjustment fails 109

 Calibrating the Touch Operation Position 112

Setting the Projector

Batch Setup Function **115**

 Setup Using a USB Flash Drive 115

 Saving settings to the USB flash drive 115

 Copying saved settings to other projectors 117

 Setup by Connecting the Computer and Projector with a USB Cable 118

 Saving settings to a computer 118

 Copying saved settings to other projectors 119

 When Setup Fails 120

Installing Multiple Projectors (Multi-Projection) **121**

 Setting the Projector ID 121

 Adjusting the Image in Multi-Projection 123

 When using the EB-735Fi/EB-725Wi 123

Projector Sync. Settings (only when using interactive functions) 124

Appendix

List of Safety Symbols **126**

General Notice **129**

Using the Product Safely



For your safety, read all the instructions in this guide before using this product. Incorrect handling that ignores instructions in this guide could damage this product or could result in personal injury or property damage. Keep this installation guide at hand for future reference.

Read the *User's Guide* and *Safety Instructions* for your projector and follow the instructions in these documents.



Safety Indications

The documentation and this product use graphical symbols to show how to use this product safely.

The indications and their meaning are as follows. Make sure you understand them properly before reading the guide.

| Symbol | Explanation |
|---|--|
|  Warning | This symbol indicates information that, if ignored, could possibly result in personal injury or even death due to incorrect handling. |
|  Caution | This symbol indicates information that, if ignored, could possibly result in personal injury or physical damage due to incorrect handling. |

Explanation of Symbols

| Symbols | Explanation |
|---|---|
|  | Symbol indicating an action that must not be done |
|  | Symbol indicating an action that should be done |
|  | Symbol indicating related or useful information |

Package Contents

Confirm that you have all necessary items before beginning installation.





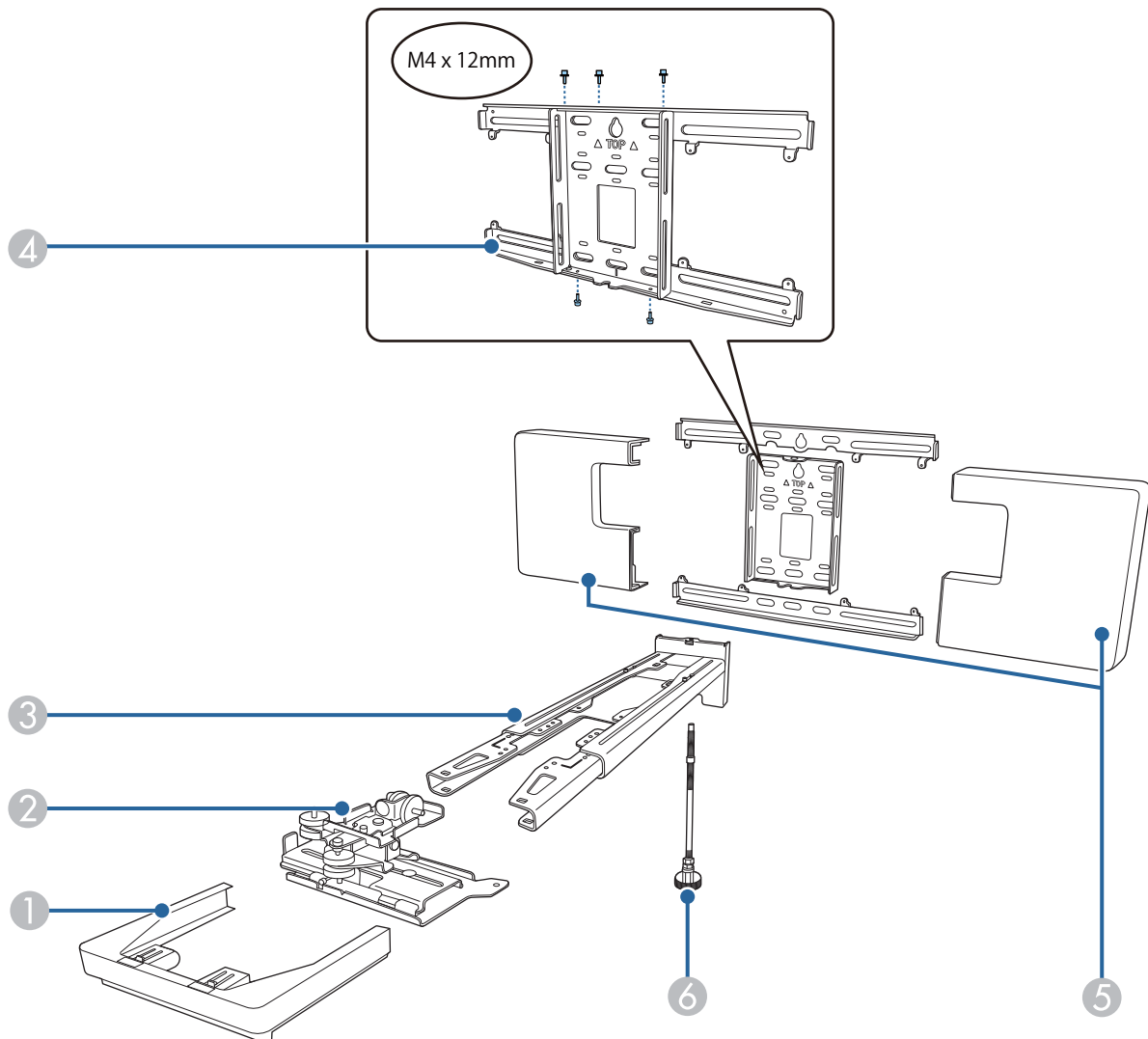

Wall Mount

Main Mount

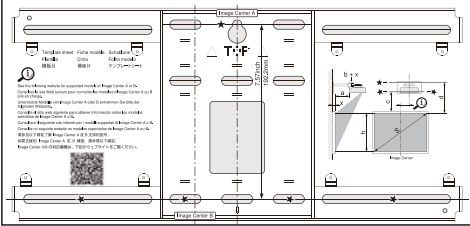
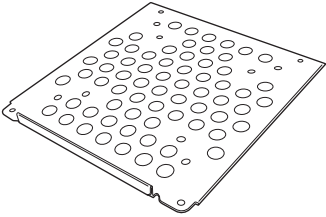

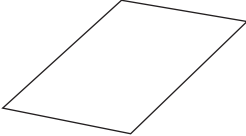
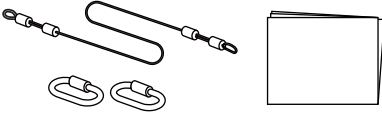

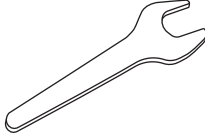

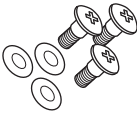
| No. | Part name |
|-----|------------------|
| ① | End cap |
| ② | Adjustment unit |
| ③ | Setting plate |
| ④ | Wall plate |
| ⑤ | Wall plate cover |
| ⑥ | Hexagonal axis |

Accessories

| Part | Name | Application |
|---|---|--|
|  | <p>Template sheet</p> | <p>Attach this to the wall before attaching the wall plate, and use it to drill necessary holes.</p> |
|  | <p>Mini PC plate</p> | <p>Attach this to the wall plate when installing a mini PC or stick PC.</p> |
|  | <p>Mini PC belt</p> | <p>Secure the PC to the plate when attaching a mini PC or a stick PC that cannot be attached using screws.</p> |
|  | <p>Cable binding belt</p> | <p>Secure excess cables after performing wiring.</p> |
|  | <p>Masking sticker</p> | <p>Stick this over the groove in the arm of setting plate to cover it up after installing.</p> |
|  | <p>Safety wire set</p> | <p>Connect to the wall mount and the projector to prevent the projector from falling. See the user's guide supplied with the safety wire set for more details.</p> |
|  | <p>Hexagon wrench (for M4)</p> | <p>-</p> |
|  | <p>Spanner (No. 13 for M6)</p> | <p>-</p> |
|  | <p>M4 x 12 mm hexagon socket head cap bolt with washer/spring washer (x13)</p> | <ul style="list-style-type: none"> Assemble the wall plate as shown in the figure on p.7 (x5) Secure the adjustment unit to the projector (x4) Secure the adjustment unit to the setting plate (x4) |
|  | <p>M6 x 20 mm hexagon shoulder head bolt with washer/spring washer (x1)</p> | <p>Secure the setting plate to the wall plate.</p> |
|  | <p>M6 x 20 mm cross recessed head shoulder screws with plastic washers (x3)</p> | <p>-</p> |

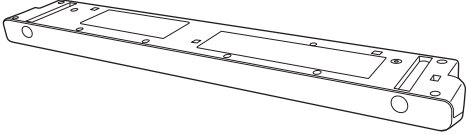
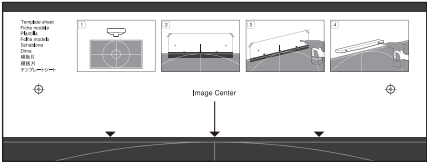
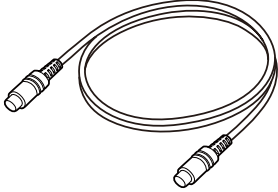
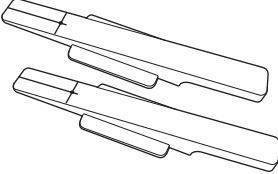

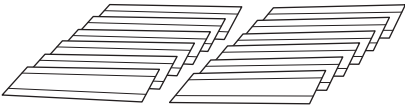
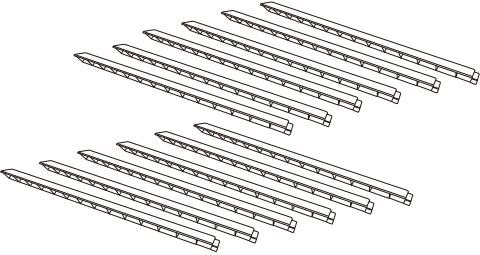
| Part | Name | Application |
|---|--|---|
|  | M3 x 6 mm cross recessed head shoulder screws (x4) | Secure the mini PC plate to the wall plate. |

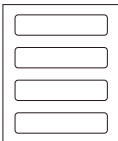
Touch Unit

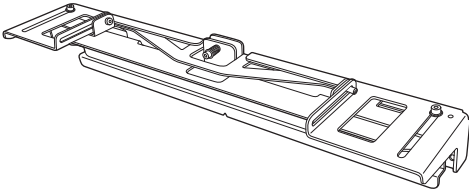
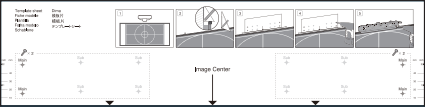

| Part | Name | Application |
|---|--|--|
|  | Touch Unit | - |
|  | Template sheet (for securing the Touch Unit) | Attach this to the wall before attaching the Touch Unit, and use it to drill necessary holes. |
|  | Touch Unit connection cable (approx. 1.8m) | Connect the Touch Unit to the projector. |
|  | Markers x2 | Attach to the screen to adjust the angle of the laser emitted by the Touch Unit. <div style="border: 1px solid black; padding: 5px; width: fit-content;">  When the finger touch operations do not work correctly, you need to use the markers again to re-calibrate the angle of the laser. Keep these in a safe place after installing. </div> |
|  | Tape for securing the markers (approx. 6 cm) x12 | Secure the markers to the projection surface. |
|  | Infrared deflectors (approx. 28.5 cm) x12 | Use these when there is a tray or frame at the bottom of the projection surface. This prevents malfunctions due to laser reflections. |
|  | Spacers for screw holes x3 | Attach them to the screw hole when securing the Touch Unit with screws. |
|  | Label x4 | Attach the label in the position of the Touch Unit. These provide markers when repositioning due to movement that occurs during use. |

Touch Unit Bracket

Use this when attaching the Touch Unit to outside of the projection surface.

| Part | Name | Application |
|---|--|---|
|  | Touch Unit Bracket | - |
|  | Template sheet (for Touch Unit Bracket) | Attach this to the wall before attaching the Touch Unit Bracket, and use it to drill necessary holes. |
|  | M4 x 25mm hexagon socket head cap bolts (x2) | Secure the Touch Unit to the Touch Unit Bracket. |
|  | Hexagon wrench (for M4) | - |

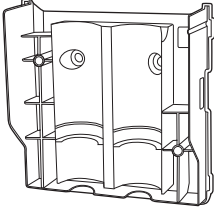
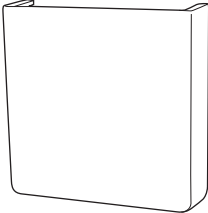
Pen Stand

| Part | Name | Application |
|---|----------------------------|--|
|  | Main unit | - |
|  | Cover | Attach to the front of the pen stand. |
|  | Spacers for screw holes x3 | Attach them to the screw hole when securing the pen stand with screws. |

Necessary Items

As well as the items supplied, you also need to prepare the following screws and tools.

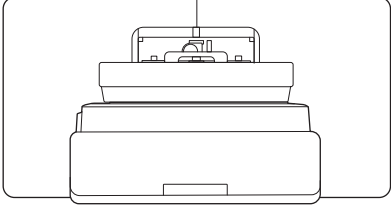
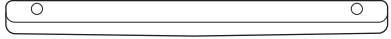
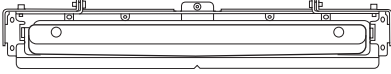
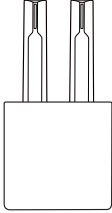
| Applicable parts | Necessary items |
|--|--|
|  | <p>For the wall mount</p> <ul style="list-style-type: none"> • M10 or 3/8 inch x 60 mm anchor bolts (for securing the wall plate: at least x4) • M10 screw (for securing the wall plate temporarily: x1) • 17 mm ratchet wrench (for adjusting hexagonal axis) • Cables to connect to the projector • Devices such as mini PCs |
|  | <p>For the Touch Unit</p> <ul style="list-style-type: none"> • M4 screws (to secure the Touch Unit: x2) |
|  | <p>For the Touch Unit bracket</p> <ul style="list-style-type: none"> • Anchor bolts or screws for the bracket (depending on what the mounting surface is made of) <ul style="list-style-type: none"> • M4 anchor bolts (x4) • 3.8 mm diameter wood screws with a length of 45 mm or more (x4) |
|  | <p>For the pen stand</p> <ul style="list-style-type: none"> • M4 x 20 mm screws (x2) |

Installation Work Flow

We recommend installing the projector and peripheral devices in the following order.

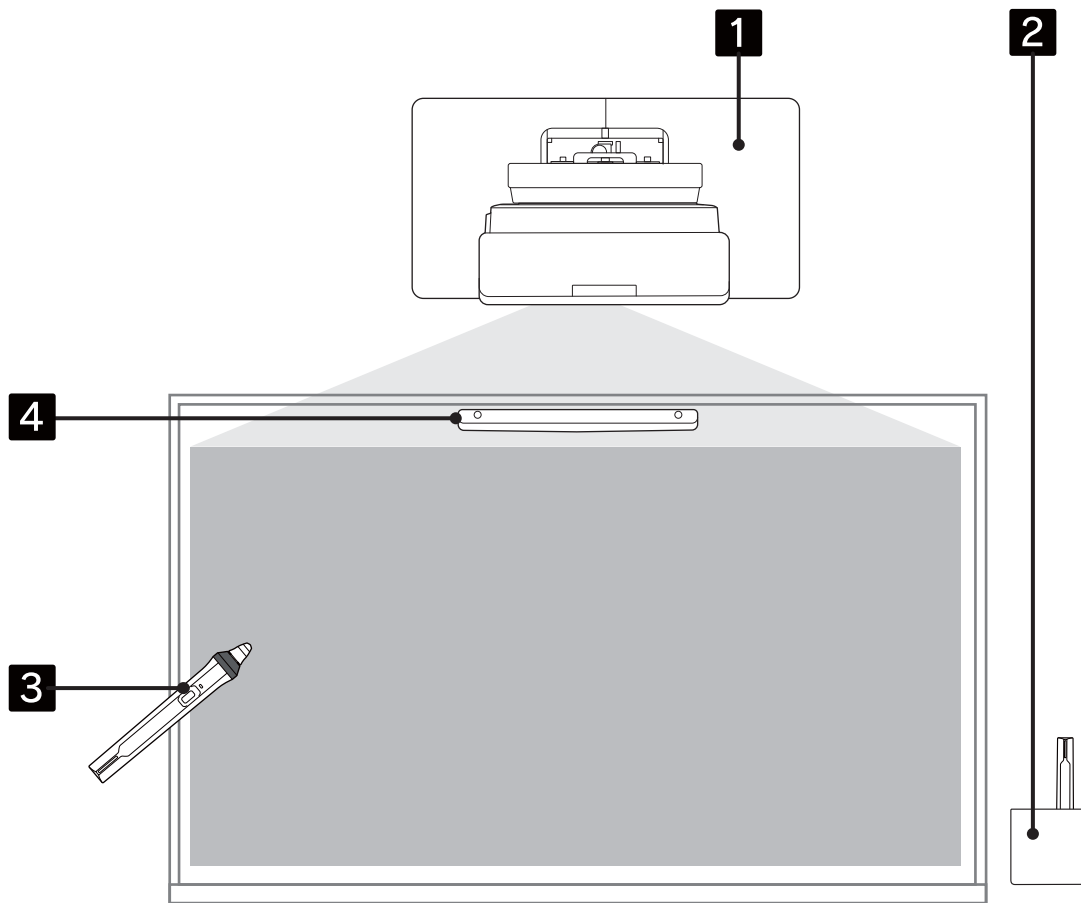

- 1 Mount projector on wall and adjust the projected image (☞ [p.16](#))
- 2 Install the pen stand (☞ [p.74](#))
- 3 Perform pen calibration (☞ [p.79](#))
- 4 Install and adjust touch unit and perform finger touch calibration (☞ [p.83](#))



When you want to use the installed Touch Unit (see the following image) as it is, adjust the laser angle ([p.104](#)).

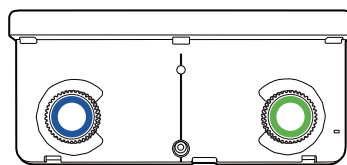

Figures of Installation Dimensions

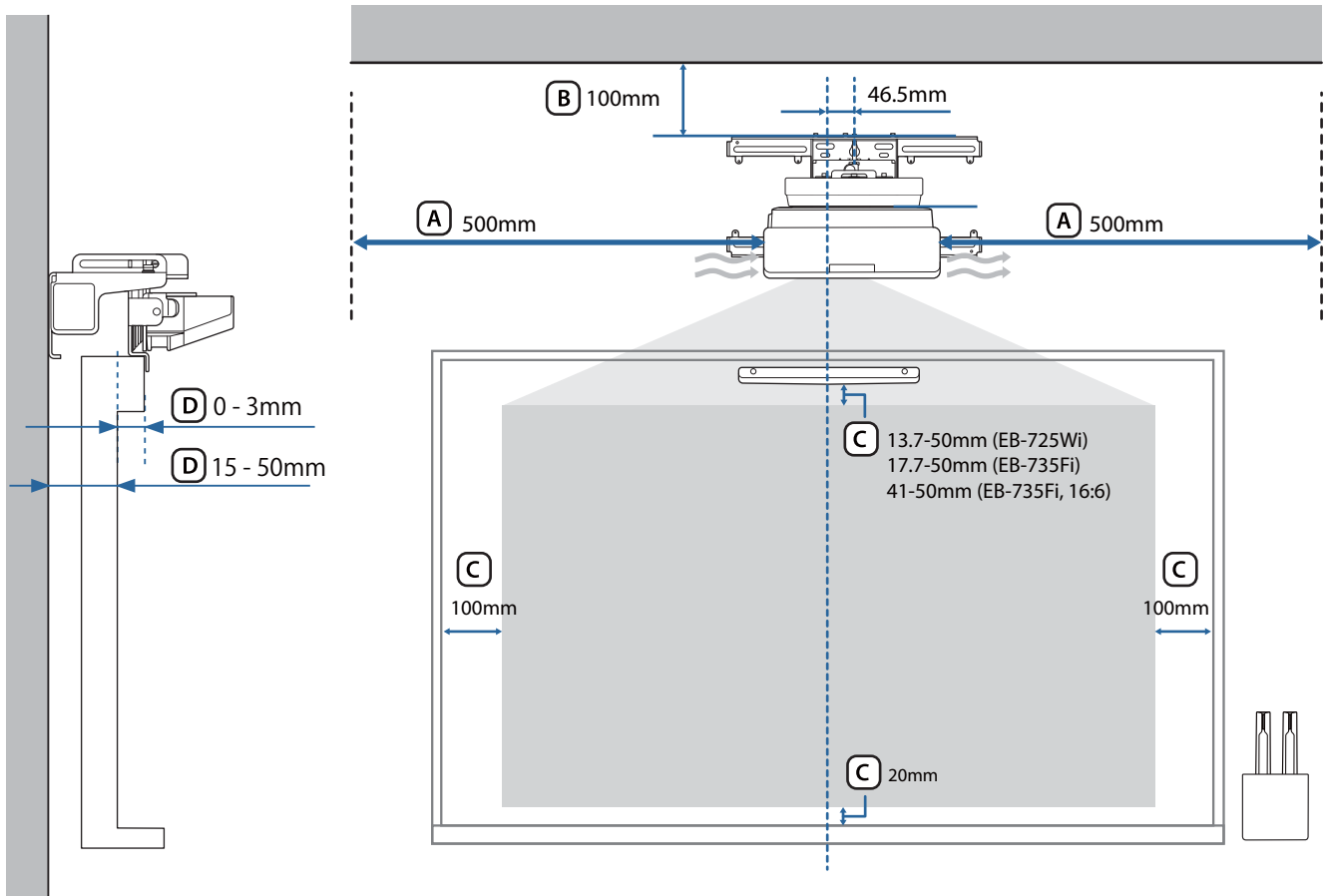

Caution

- When installing the projector, make sure there is a gap between the wall and the projector's air exhaust and intake vents. (See figure (A) above)
- When using the Touch Unit, make sure there is enough space around the projection screen. (See figure (C) above)
- When installing the Touch Unit using the Touch Unit bracket, check the thickness of the frame around the screen and the length from the installation surface to the screen surface. (See figure (D) above)

 Leaving a gap of approximately 100 mm from the ceiling to the top of the wall plate makes it easier to install and remove the projector. (See figure (B) above)

When you want to use the installed Touch Unit as it is, leave a gap of 25 to 100 mm between the bottom of the touch unit and the top of the image. You may need to re-install the Touch Unit to project at a different size or aspect ratio.

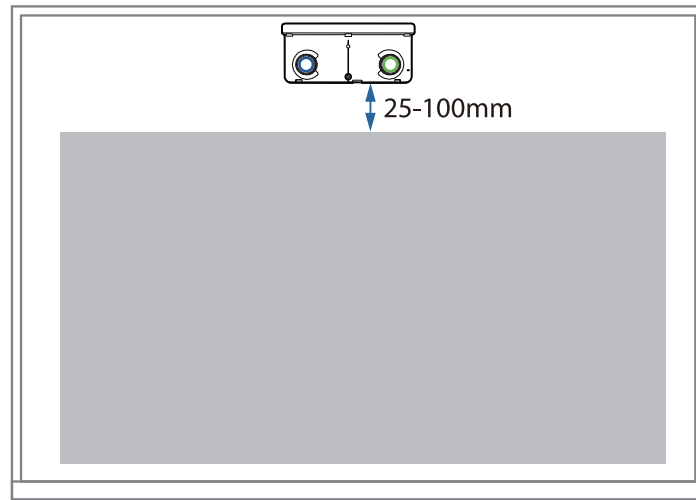

Connection Figure







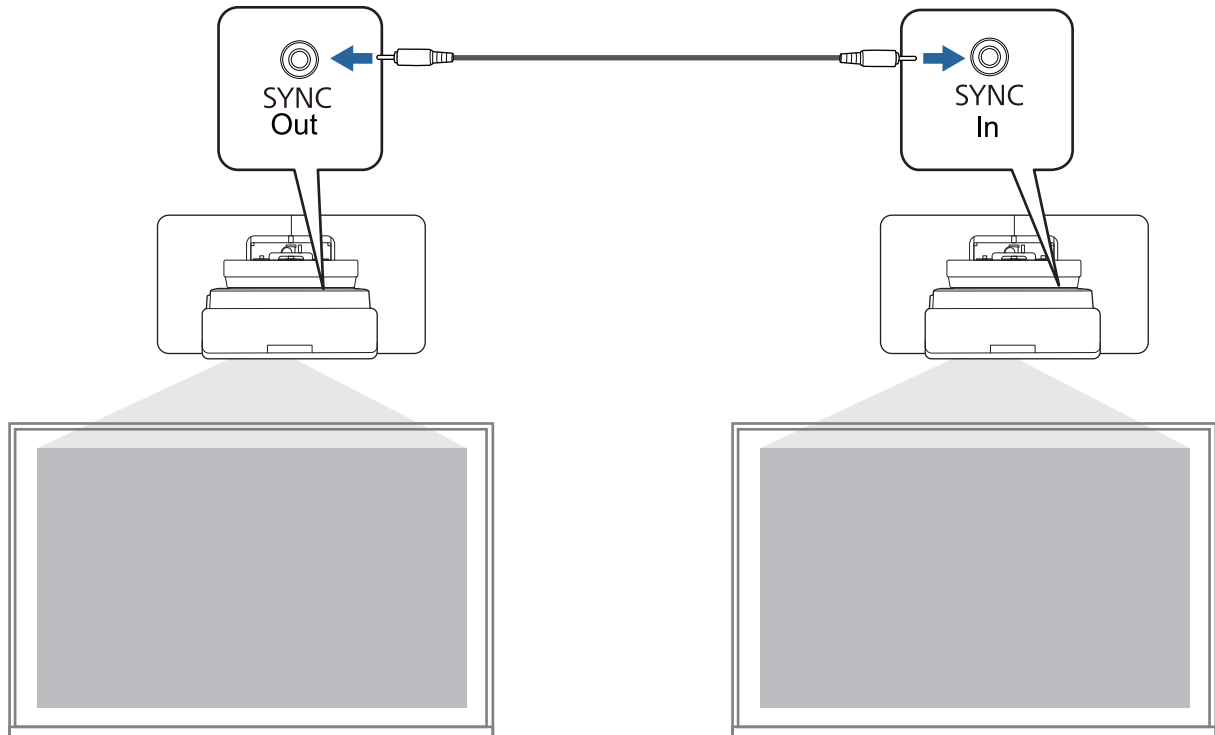



Connecting Multiple Projectors













If interactive pen operations interfere with projectors that have been installed nearby, connect the projectors by using the optional remote control cable set (ELPKC28).









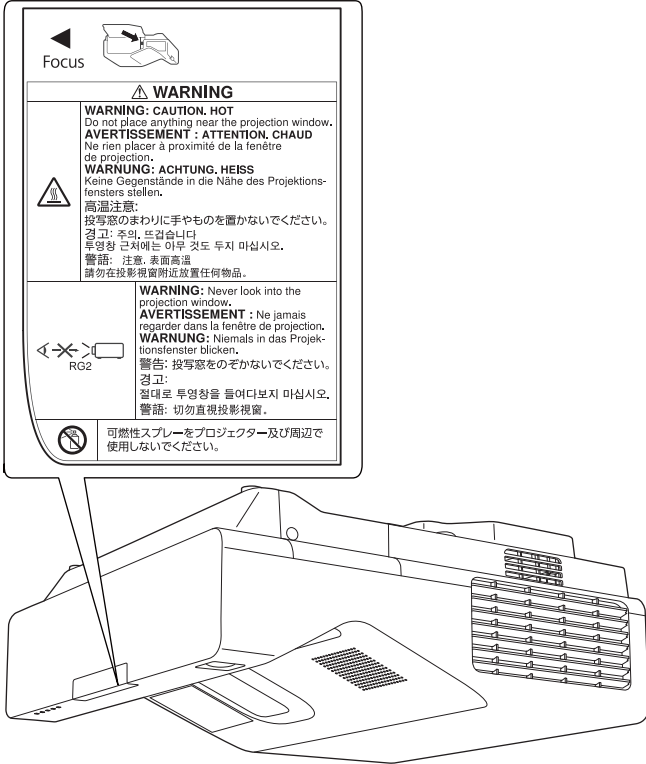

After connecting the cable, set **Installation of Projectors** > **Sync of Projectors** to **Wired** from the **Pen/Touch** menu to reduce the interference.











Cautions on Installing the Wall Mount

|  Warning | |
|---|---|
| <p>The Wall mount is exclusively for mounting the projector on a wall. If anything other than a projector is mounted, the weight may result in damage.</p> <p>If this product falls, it could cause death or personal injury.</p> |  |
| <p>The installation work (wall mounting) should be performed by specialists who have technical knowledge and ability. Incomplete or incorrect installation could cause the product to fall and cause personal injury or property damage.</p> |  |
| <p>Follow the steps in this guide to install the Wall mount, and be sure to use the bolts and screws specified in this guide.</p> <p>If the instructions are not followed, this product may fall, resulting in personal injury or an accident.</p> |  |
| <p>Handle the power cord carefully.</p> <p>Incorrect handling may cause fire or electric shock. Observe the following precautions when handling:</p> <ul style="list-style-type: none"> • Do not handle the power plug with wet hands. • Do not use a power cord that is damaged or modified. • Do not pull the power cord with too much force when routing the cable through the setting plate. |  |
| <p>Do not install the setting plate in a place where it might be subjected to vibration or shock.</p> <p>This could cause damage to the projector or mounting surface. If this product falls, it could cause death or personal injury.</p> |  |
| <p>When installing on a wall, install so that it can sufficiently support the mass of the projector and the Wall mount and resist any horizontal vibration. Use M10 or 3/8 inch x 60 mm nuts and bolts.</p> <p>Nuts and bolts smaller than M10 or 3/8 inch x 60 mm could cause the setting plate to fall. Epson accepts no responsibility for any damage or injury caused by lack of wall strength or inadequate installation.</p> |  |
| <p>The installation work should be performed by at least two qualified service personnel. If you need to loosen any screws during installation, be careful not to drop this product.</p> <p>If this product falls, it could cause death or personal injury.</p> |  |
| <p>When installing this product on a wall, the wall requires enough strength to hold the projector and the Wall mount.</p> <p>This product should be installed on a concrete wall.</p> <p>The maximum combined weight of the projector and the Wall mount is approximately 15 kg (not including cables).</p> <p>Ensure the strength of the wall before mounting this product on the wall. If the wall is not strong enough, reinforce the wall before installation.</p> |  |
| <p>Inspect the setting plate on a regular basis to ensure there are no broken parts or loose screws.</p> <p>If any parts are damaged, stop using the setting plate immediately. If this product falls, it could cause death or personal injury.</p> |  |

|  Warning | |
|---|---|
| <p>Do not disassemble or remodel this product.</p> <p>There are numerous high-voltage sections inside the product that could cause a fire, electric shock, or an accident.</p> |  |
| <p>Do not hang on this product. Do not hang heavy objects on this product.</p> <p>If this product falls, it could cause death or personal injury.</p> |  |
| <p>Do not use adhesives, lubricants, or oils to install or adjust the Wall mount.</p> <p>If you use adhesives to prevent the screws from loosening or things such as lubricants or oils on the slide plate fixing part of the projector, the case may crack and cause the projector to fall, resulting in personal injury or property damage.</p> |  |
| <p>Tighten all screws firmly after adjustment.</p> <p>Otherwise, the product may fall and cause personal injury or property damage.</p> |  |
| <p>Never loosen the bolts and nuts after installation.</p> <p>Confirm that the screws have not become loose on a regular basis. If you find any loose screws, tighten them firmly. Otherwise, the product may fall and cause personal injury or property damage.</p> |  |
| <p>Route the cables so that they are not interfered with the nuts and bolts.</p> <p>Incorrect handling of the cables may cause fire or electric shock.</p> |  |
| <p>When turning on the projector, do not look into the projection window.</p> <p>This could cause damage to eyesight due to the powerful light emitted. Take particular care when there are children present. When turning on the projector at a distance using the remote control, make sure there is no one looking into the projection window.</p> |  |
| <p>When using the projector, do not place any objects or put your hand near the projection window.</p> <p>This area is dangerous as it reaches a high temperature due to the concentrated projection light.</p> |  |
| <p>Do not use the projector in a location subject to combustible or explosive gas.</p> <p>High temperatures within the projector may cause ignition and a fire to occur.</p> |  |
| <p>Only a specialist should remove or reinstall the projector, including for maintenance and repairs.</p> <p>See the projector's <i>User's Guide</i> for instructions on maintenance and repairs.</p> |  |
| <p>If any abnormalities occur with this product, immediately disconnect the cables from the product, and then contact your local dealer or the nearest Epson service call center.</p> <p>Continuing to use the product in an abnormal condition could cause a fire, electric shock, or visual impairment.</p> |  |

|  Warning | |
|---|---|
| <p>Laser warning labels have been attached to the projector.</p> <p>Do not look into the laser beam emitted from the projection window while projecting. (Compliant with IEC/EN60825-1:2014)</p> <div style="text-align: center;">  </div> |  |
| <p>Never open any cases on the projector.</p> <p>Electrical voltages inside the projector can cause severe injury.</p> |  |
| <p>Do not look directly into the projector's light source.</p> <p>Possibly hazardous optical radiation emitted from this product. Eye injury may result.</p> |  |
|  Caution | |
| <p>Do not install this product in a location where the operating temperature for your projector model may be exceeded.</p> <p>Such an environment may damage the projector.</p> |  |
| <p>Install this product in a place free from excessive dust and humidity to prevent the lens or optical components from becoming dirty.</p> |  |
| <p>Do not use excessive force when adjusting this product.</p> <p>This product may break, resulting in personal injury.</p> |  |
| <p>This projector is a Class 1 laser product that complies with the IEC/EN60825-1: 2014 international standard for lasers.</p> |  |
| <p>Do not disassemble the projector when disposing of it.</p> <p>Dispose according to your local or national laws and regulations.</p> |  |

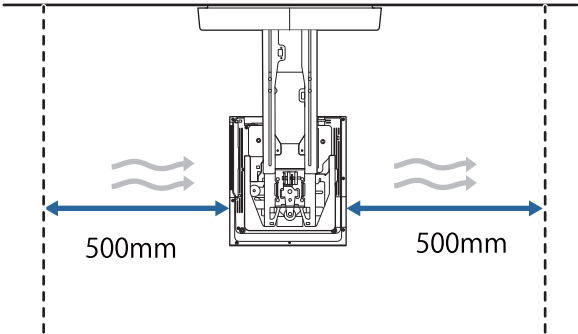
Cautions on the Installation Location of the Wall Mount

|  Warning | |
|---|---|
| <p>Do not install in a location subject to oily smoke or smoke for events.</p> <p>If oils and so on stick to the slide plate fixing part of the projector, the case may crack and cause the projector to fall, resulting in personal injury or property damage.</p> |  |
|  Caution | |
| <p>Do not install the projector or the screen in a location subject to direct sunlight.</p> <p>If the projector or the screen are subject to direct sunlight, the interactive function may not operate correctly.</p> |  |
| <p>Carry out power supply wiring work at the installation location of the projector in advance.</p> |  |
| <p>Install the projector away from other electric devices such as fluorescent lights or air conditioners.</p> <p>Some types of fluorescent lights could interfere with the remote control or the pen.</p> |  |
| <p>When installing the projector, make sure there is a gap between the wall and the projector's air exhaust and intake vents as shown in the following image.</p> <div style="text-align: center;">  </div> |  |
| <p>When installing two or more projectors in parallel, make sure the temperature of the surrounding environment is less than 35°C.</p> <p>If the environment is too hot, the projector may overheat and the power may turn off without warning.</p> |  |

 Caution

When installing two or more projectors in parallel, leave a gap of at least 1,500 mm between the projectors.

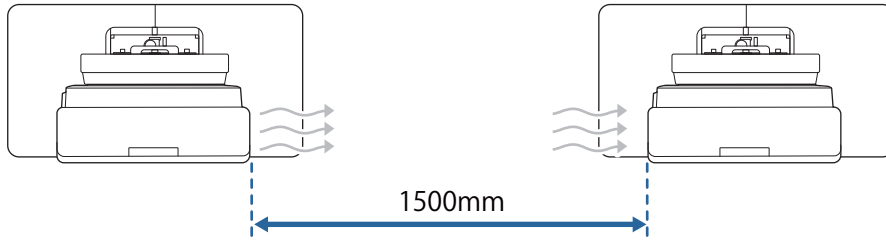

If you cannot secure a gap of approx. 1,200 mm, install a partition to block the heat vented from the projector's air exhaust vent.

The partitions should be larger than the exhaust vent (approx. 20 mm in all directions), and installed approximately 400 mm from the exhaust vent and 200 mm from the intake vents.

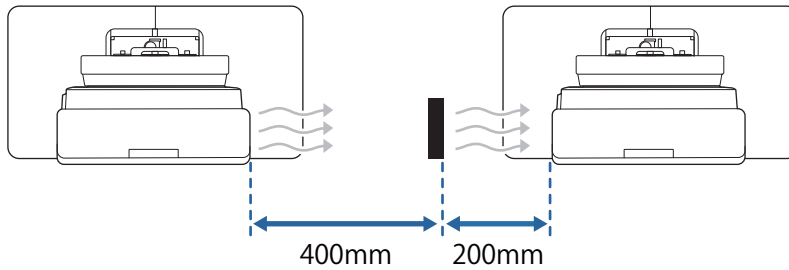

Install and adjust the projector at a room temperature that is close to the actual intended usage environment.



If the temperature changes, the position of the image may shift or the accuracy of the pen may decline.

Install the projector so that it is tilted at an angle of no more than +3 degrees or -3 degrees vertically and horizontally in relation to the screen.



When using interactive functions, install the projector so that the projected image is within reach.



We recommend using stick-on screens or board screens.



Wall Mount Specifications

| Item | Specification |
|---|-----------------|
| Wall mount mass (setting plate, hexagonal axis, adjustment unit, wall plate, wall plate cover, end cap) | Approx. 9.2 kg |
| Maximum load capacity | Approx. 15.0 kg |

External Dimensions

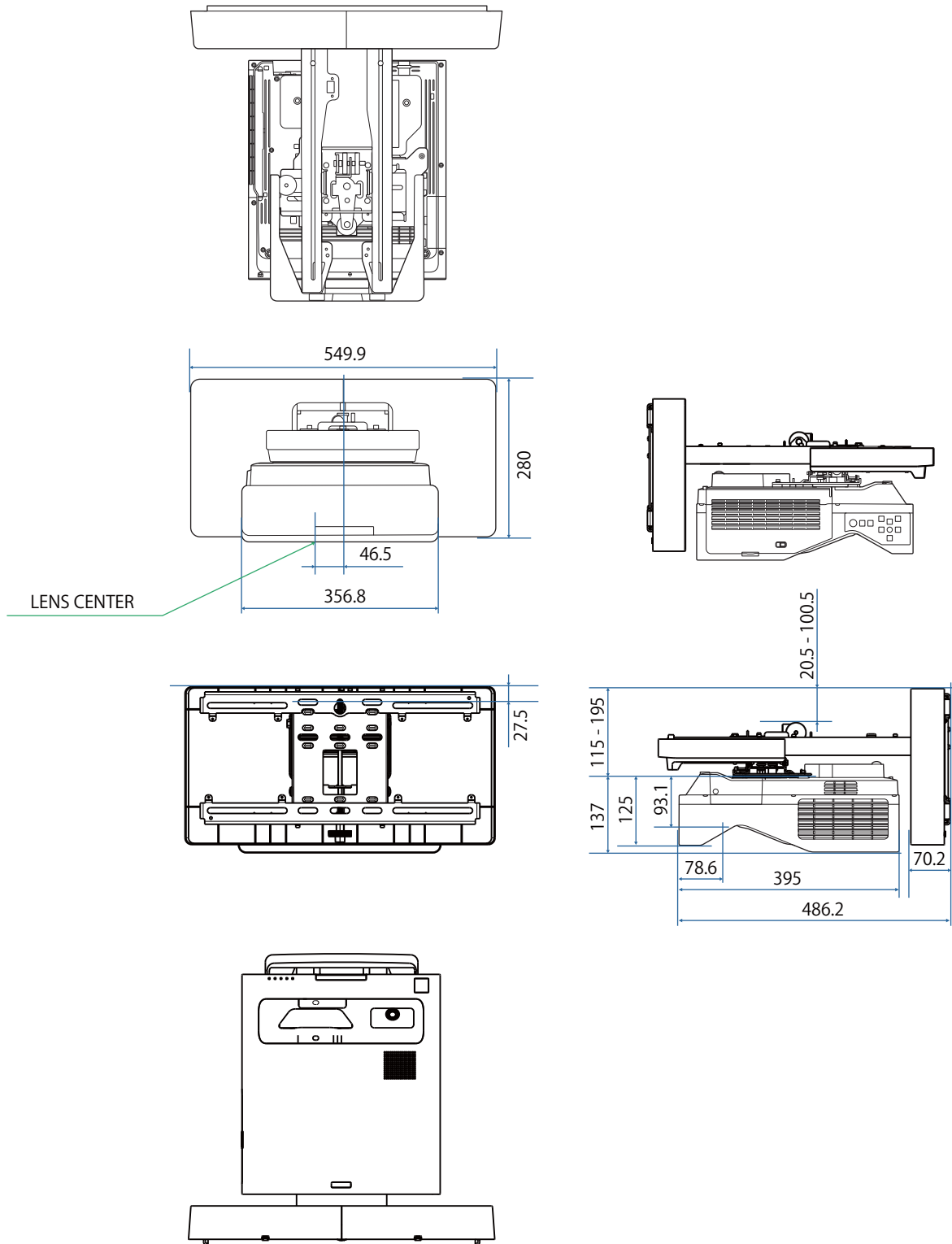

Installing the Wall mount

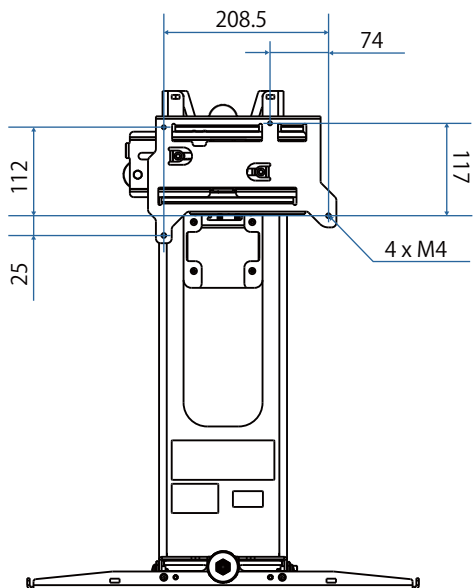
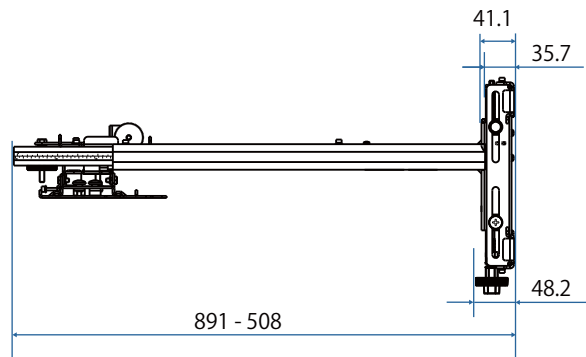
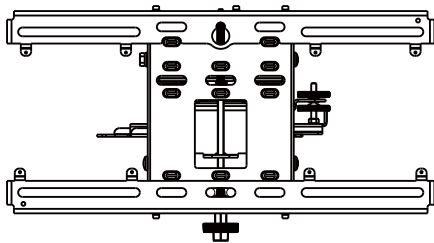
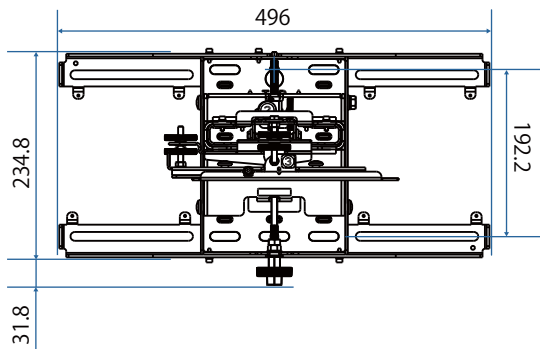
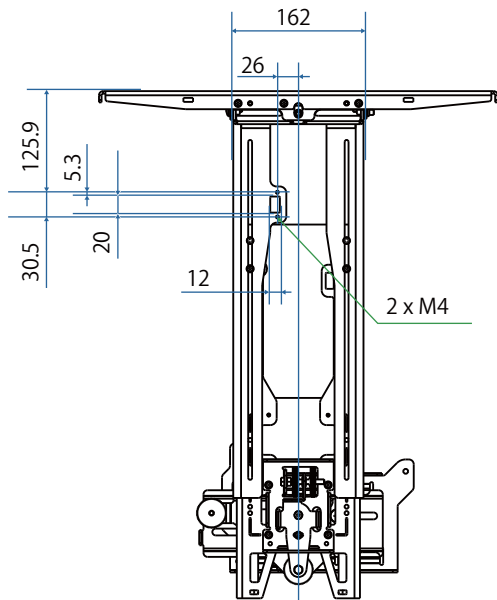

■ Horizontal slide

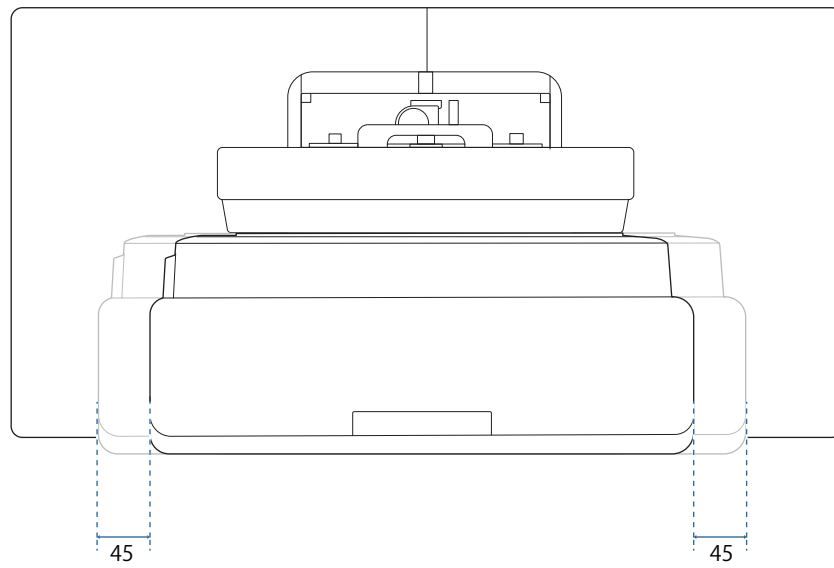

■ Forward/backward slide

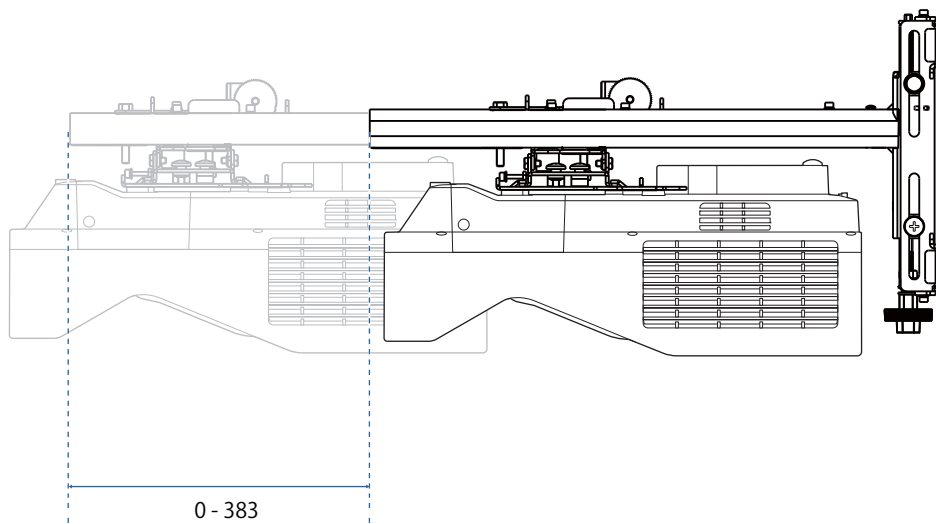

Mini PC Installation Plate

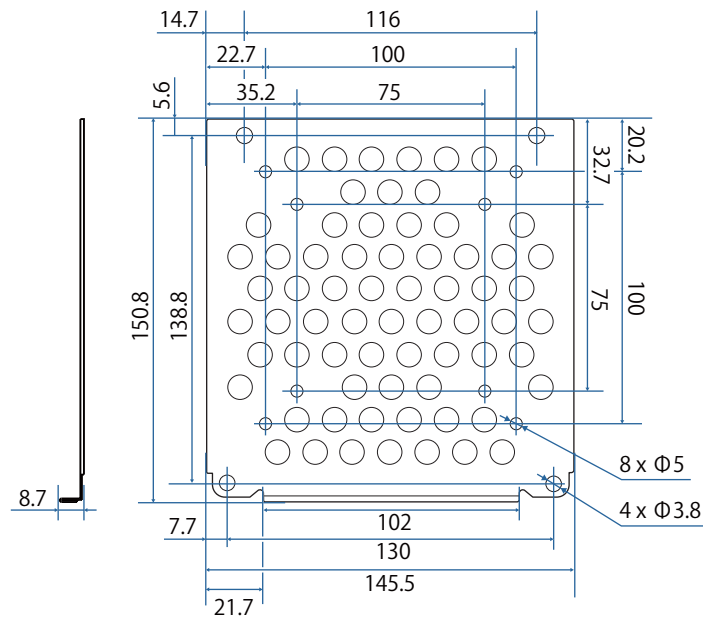

| Item | Specification |
|--|----------------------------------|
| Screw holes for installing PC (VESA compliant) | 75 mm x 75 mm 100 mm x 100 mm |
| Supported PC sizes | Within 150 mm x 150 mm x 44 mm |
| Supported PC weight | 0.7 kg or less |

Installing Accessories

When installing a switcher or a tuner, use the screw holes shown in the figure below to secure them.

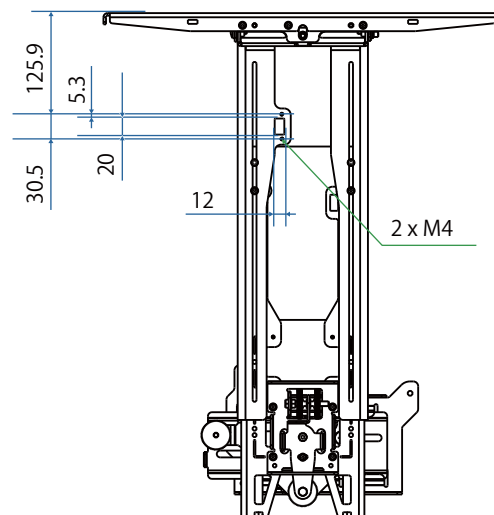

Before installing, check that the total weight, including the projector and connection cables, is below the maximum load capacity for the Wall Mount. (☛ "Wall Mount Specifications" p.21)

Installation Procedure for the Wall Mount

Follow the work flow below to install the wall mount.

Route the cables before installing the wall mount according to your installation environment.

- 1 Check the projection distance tables to determine the installation position (☞ p.28)
- 2 Attach the adjustment unit to the projector (☞ p.43)
- 3 Install the wall plate on the wall (☞ p.44)
- 4 Adjust the arm length of the setting plate, and then attach it to the wall plate (☞ p.46)
- 5 Attach the adjustment unit to the setting plate, and then connect the cables and peripheral devices (☞ p.51)
- 6 Adjust the position of the image (☞ p.55)
- 7 Attach the covers (☞ p.71)

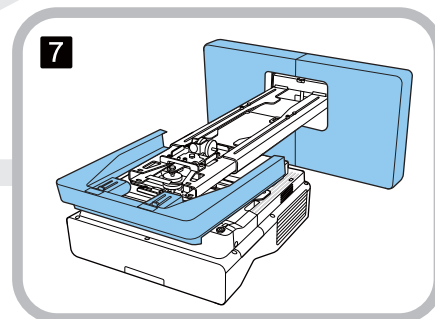
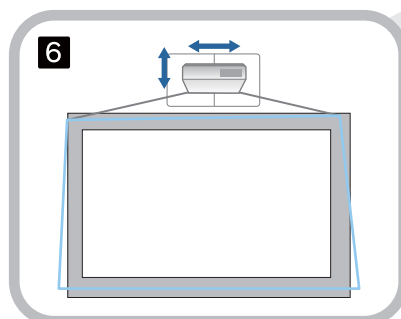
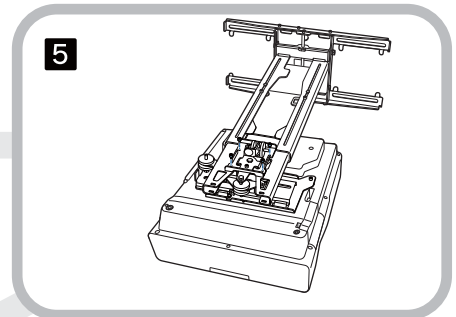
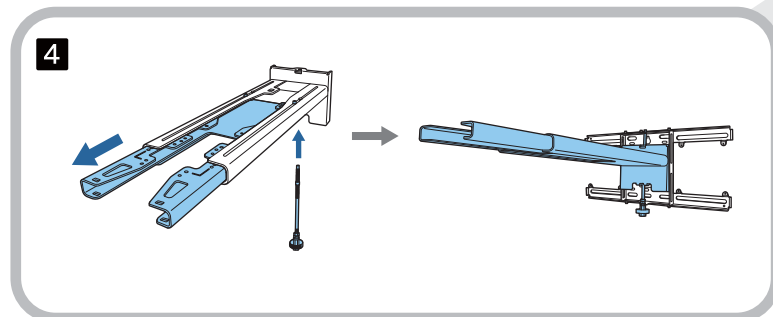
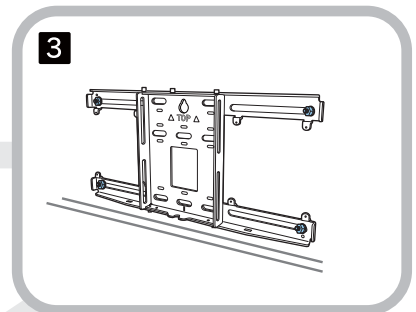
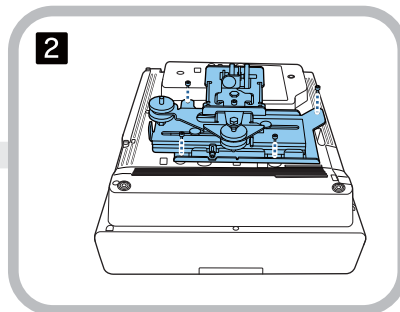
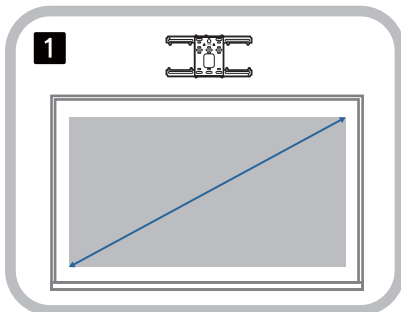

Attaching the Mount

■ Determining the installation position (projection distance tables)

Determine the installation position of the wall plate according to the size of the screen (S) you want to project on to. See the following figure to check the values from a to d. This is the value when the setting plate is in the middle of the wall plate (See ☆ in the following illustration).

The offset value for the center of the screen being projected and the center of the Wall Plate is 46.5 mm.

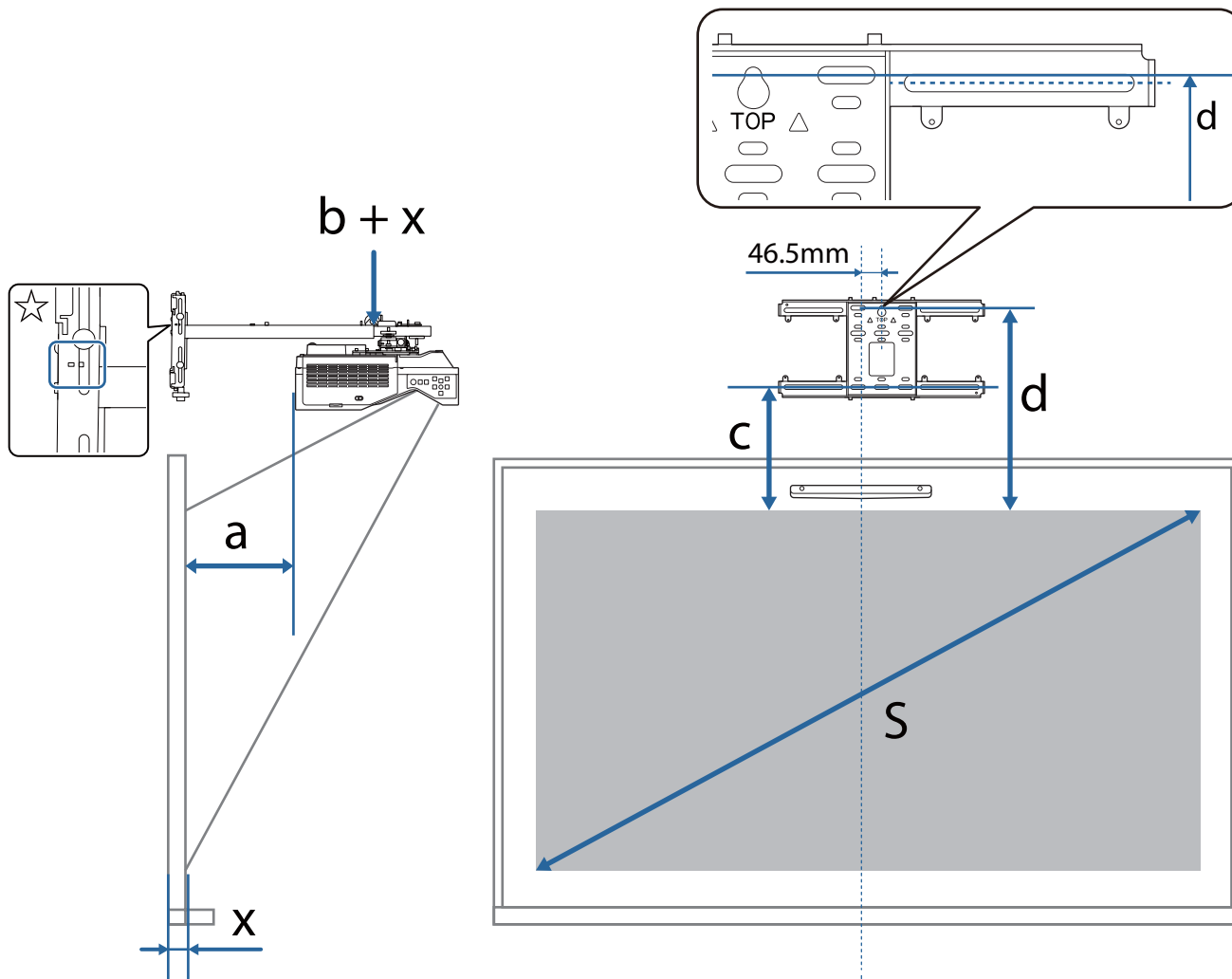

a: Minimum projection distance (Wide)

b + x: Number on the arm slide scale on the setting plate (Max. 533 mm)

x: Distance from the wall to the projection surface (15 to 50 mm when using the touch unit bracket (p.13))

c: Distance from the top edge of the image to the bottom installation screw hole for the wall plate

d: Distance from the top edge of the image to the temporary screw hole for the wall plate

S: Projected image size

See the following for the values for c and d when projecting at an aspect ratio of 16:6.

When using the interactive features with an aspect ratio of 16:6, set the **Screen Position** to a vertically central or higher position.

(EB-735Fi)

- c1/d1: When the **Screen Position** is in the center
- c2/d2: When the **Screen Position** is at the top

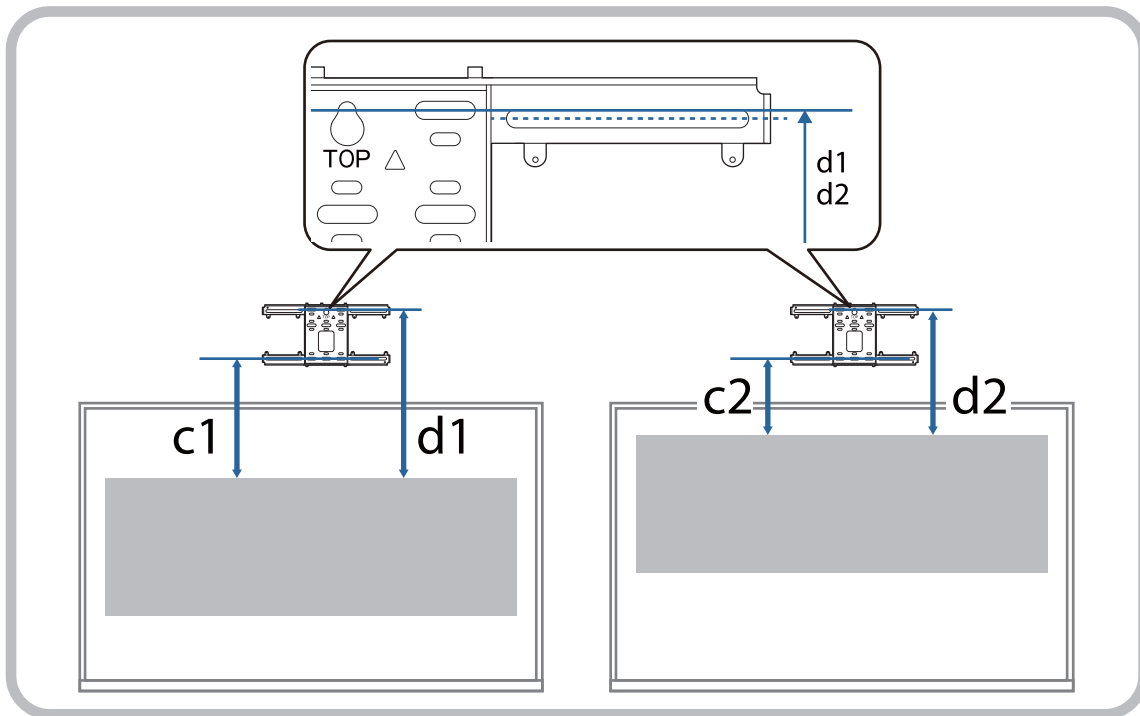

 EB-735Fi

16:9 projected image

[Unit: mm]

| | S | a | b | c | d |
|------|-------------|-----|-----|-----|-----|
| 65 " | 1439 × 809 | 57 | 115 | 212 | 404 |
| 66 " | 1461 × 822 | 63 | 121 | 215 | 407 |
| 67 " | 1483 × 834 | 69 | 127 | 218 | 410 |
| 68 " | 1505 × 847 | 75 | 133 | 221 | 413 |
| 69 " | 1528 × 859 | 81 | 139 | 224 | 416 |
| 70 " | 1550 × 872 | 87 | 145 | 227 | 419 |
| 71 " | 1572 × 884 | 93 | 151 | 230 | 423 |
| 72 " | 1594 × 897 | 99 | 157 | 233 | 426 |
| 73 " | 1616 × 909 | 105 | 163 | 237 | 429 |
| 74 " | 1638 × 921 | 111 | 169 | 240 | 432 |
| 75 " | 1660 × 934 | 117 | 175 | 243 | 435 |
| 76 " | 1682 × 946 | 123 | 181 | 246 | 438 |
| 77 " | 1705 × 959 | 129 | 188 | 249 | 441 |
| 78 " | 1727 × 971 | 135 | 194 | 252 | 444 |
| 79 " | 1749 × 984 | 141 | 200 | 255 | 447 |
| 80 " | 1771 × 996 | 147 | 206 | 258 | 450 |
| 81 " | 1793 × 1009 | 153 | 212 | 261 | 454 |
| 82 " | 1815 × 1021 | 159 | 218 | 265 | 457 |
| 83 " | 1837 × 1034 | 165 | 224 | 268 | 460 |
| 84 " | 1860 × 1046 | 171 | 230 | 271 | 463 |
| 85 " | 1882 × 1058 | 177 | 236 | 274 | 466 |
| 86 " | 1904 × 1071 | 183 | 242 | 277 | 469 |
| 87 " | 1926 × 1083 | 189 | 248 | 280 | 472 |
| 88 " | 1948 × 1096 | 195 | 254 | 283 | 475 |
| 89 " | 1970 × 1108 | 201 | 260 | 286 | 478 |

| | S | a | b | c | d |
|-------|-------------|-----|-----|-----|-----|
| 90 " | 1992 × 1121 | 207 | 179 | 289 | 482 |
| 91 " | 2015 × 1133 | 213 | 185 | 292 | 485 |
| 92 " | 2037 × 1146 | 219 | 191 | 296 | 488 |
| 93 " | 2059 × 1158 | 225 | 197 | 299 | 491 |
| 94 " | 2081 × 1171 | 231 | 203 | 302 | 494 |
| 95 " | 2103 × 1183 | 237 | 209 | 305 | 497 |
| 96 " | 2125 × 1195 | 243 | 215 | 308 | 500 |
| 97 " | 2147 × 1208 | 249 | 221 | 311 | 503 |
| 98 " | 2170 × 1220 | 255 | 227 | 314 | 506 |
| 99 " | 2192 × 1233 | 261 | 233 | 317 | 510 |
| 100 " | 2214 × 1245 | 267 | 239 | 320 | 513 |

4:3 projected image

[Unit: mm]

| | S | a | b | c | d |
|------|-------------|-----|-----|-----|-----|
| 54 " | 1097 × 823 | 63 | 122 | 215 | 407 |
| 55 " | 1118 × 838 | 70 | 129 | 219 | 411 |
| 56 " | 1138 × 853 | 78 | 137 | 223 | 415 |
| 57 " | 1158 × 869 | 85 | 144 | 226 | 419 |
| 58 " | 1179 × 884 | 92 | 151 | 230 | 422 |
| 59 " | 1199 × 899 | 100 | 159 | 234 | 426 |
| 60 " | 1219 × 914 | 107 | 166 | 238 | 430 |
| 61 " | 1240 × 930 | 115 | 173 | 242 | 434 |
| 62 " | 1260 × 945 | 122 | 181 | 245 | 438 |
| 63 " | 1280 × 960 | 129 | 188 | 249 | 441 |
| 64 " | 1300 × 975 | 137 | 195 | 253 | 445 |
| 65 " | 1321 × 991 | 144 | 203 | 257 | 449 |
| 66 " | 1341 × 1006 | 151 | 210 | 261 | 453 |
| 67 " | 1361 × 1021 | 159 | 218 | 264 | 457 |
| 68 " | 1382 × 1036 | 166 | 225 | 268 | 461 |
| 69 " | 1402 × 1052 | 173 | 232 | 272 | 464 |
| 70 " | 1422 × 1067 | 181 | 240 | 276 | 468 |
| 71 " | 1443 × 1082 | 188 | 247 | 280 | 472 |
| 72 " | 1463 × 1097 | 195 | 254 | 284 | 476 |
| 73 " | 1483 × 1113 | 203 | 262 | 287 | 480 |
| 74 " | 1504 × 1128 | 210 | 269 | 291 | 483 |
| 75 " | 1524 × 1143 | 218 | 276 | 295 | 487 |
| 76 " | 1544 × 1158 | 225 | 284 | 299 | 491 |
| 77 " | 1565 × 1173 | 232 | 291 | 303 | 495 |
| 78 " | 1585 × 1189 | 240 | 298 | 306 | 499 |
| 79 " | 1605 × 1204 | 247 | 306 | 310 | 502 |

| | S | a | b | c | d |
|------|-------------|-----|-----|-----|-----|
| 80 " | 1626 × 1219 | 254 | 313 | 314 | 506 |
| 81 " | 1646 × 1234 | 262 | 320 | 318 | 510 |
| 82 " | 1666 × 1250 | 269 | 328 | 322 | 514 |
| 83 " | 1687 × 1265 | 276 | 335 | 325 | 518 |
| 84 " | 1707 × 1280 | 284 | 343 | 329 | 521 |
| 85 " | 1727 × 1295 | 291 | 350 | 333 | 525 |
| 86 " | 1748 × 1311 | 298 | 357 | 337 | 529 |
| 87 " | 1768 × 1326 | 306 | 365 | 341 | 533 |
| 88 " | 1788 × 1341 | 313 | 372 | 344 | 537 |
| 89 " | 1808 × 1356 | 320 | 379 | 348 | 540 |
| 90 " | 1829 × 1372 | 328 | 300 | 352 | 544 |
| 91 " | 1849 × 1387 | 335 | 307 | 356 | 548 |
| 92 " | 1869 × 1402 | 343 | 314 | 360 | 552 |
| 93 " | 1890 × 1417 | 350 | 322 | 363 | 556 |
| 94 " | 1910 × 1433 | 357 | 329 | 367 | 559 |
| 95 " | 1930 × 1448 | 365 | 336 | 371 | 563 |
| 96 " | 1951 × 1463 | 372 | 344 | 375 | 567 |
| 97 " | 1971 × 1478 | 379 | 351 | 379 | 571 |
| 98 " | 1991 × 1494 | 387 | 358 | 382 | 575 |

16:10 projected image

[Unit: mm]

| | S | a | b | c | d |
|------|-------------|-----|-----|-----|-----|
| 65 " | 1400 × 875 | 88 | 147 | 228 | 420 |
| 66 " | 1422 × 888 | 95 | 154 | 231 | 424 |
| 67 " | 1443 × 902 | 101 | 160 | 235 | 427 |
| 68 " | 1465 × 915 | 108 | 167 | 238 | 430 |
| 69 " | 1486 × 929 | 114 | 173 | 241 | 434 |
| 70 " | 1508 × 942 | 121 | 180 | 245 | 437 |
| 71 " | 1529 × 956 | 127 | 186 | 248 | 440 |
| 72 " | 1551 × 969 | 134 | 193 | 252 | 444 |
| 73 " | 1572 × 983 | 140 | 199 | 255 | 447 |
| 74 " | 1594 × 996 | 147 | 206 | 258 | 450 |
| 75 " | 1615 × 1010 | 153 | 212 | 262 | 454 |
| 76 " | 1637 × 1023 | 160 | 219 | 265 | 457 |
| 77 " | 1659 × 1037 | 166 | 225 | 268 | 461 |
| 78 " | 1680 × 1050 | 173 | 232 | 272 | 464 |
| 79 " | 1702 × 1063 | 179 | 238 | 275 | 467 |
| 80 " | 1723 × 1077 | 186 | 244 | 278 | 471 |
| 81 " | 1745 × 1090 | 192 | 251 | 282 | 474 |
| 82 " | 1766 × 1104 | 199 | 257 | 285 | 477 |
| 83 " | 1788 × 1117 | 205 | 264 | 289 | 481 |
| 84 " | 1809 × 1131 | 212 | 270 | 292 | 484 |
| 85 " | 1831 × 1144 | 218 | 277 | 295 | 487 |
| 86 " | 1852 × 1158 | 225 | 283 | 299 | 491 |
| 87 " | 1874 × 1171 | 231 | 290 | 302 | 494 |
| 88 " | 1895 × 1185 | 238 | 296 | 305 | 498 |
| 89 " | 1917 × 1198 | 244 | 303 | 309 | 501 |

| | S | a | b | c | d |
|-------|-------------|-----|-----|-----|-----|
| 90 " | 1939 × 1212 | 251 | 222 | 312 | 504 |
| 91 " | 1960 × 1225 | 257 | 229 | 315 | 508 |
| 92 " | 1982 × 1239 | 264 | 235 | 319 | 511 |
| 93 " | 2003 × 1252 | 270 | 242 | 322 | 514 |
| 94 " | 2025 × 1265 | 277 | 248 | 325 | 518 |
| 95 " | 2046 × 1279 | 283 | 255 | 329 | 521 |
| 96 " | 2068 × 1292 | 290 | 261 | 332 | 524 |
| 97 " | 2089 × 1306 | 296 | 268 | 336 | 528 |
| 98 " | 2111 × 1319 | 303 | 274 | 339 | 531 |
| 99 " | 2132 × 1333 | 309 | 281 | 342 | 534 |
| 100 " | 2154 × 1346 | 316 | 287 | 346 | 538 |

16:6 projected image

[Unit: mm]

| | S | a | b | c1 | d1 | c2 | d2 |
|------|------------|-----|-----|-----|-----|-----|-----|
| 60 " | 1427 × 535 | 53 | 112 | 344 | 536 | 210 | 402 |
| 61 " | 1451 × 544 | 60 | 119 | 349 | 542 | 213 | 406 |
| 62 " | 1475 × 553 | 66 | 125 | 355 | 547 | 217 | 409 |
| 63 " | 1498 × 562 | 73 | 132 | 360 | 553 | 220 | 412 |
| 64 " | 1522 × 571 | 79 | 138 | 366 | 558 | 223 | 416 |
| 65 " | 1546 × 580 | 86 | 144 | 372 | 564 | 227 | 419 |
| 66 " | 1570 × 589 | 92 | 151 | 377 | 569 | 230 | 422 |
| 67 " | 1593 × 598 | 98 | 157 | 383 | 575 | 233 | 426 |
| 68 " | 1617 × 606 | 105 | 164 | 388 | 581 | 237 | 429 |
| 69 " | 1641 × 615 | 111 | 170 | 394 | 586 | 240 | 432 |
| 70 " | 1665 × 624 | 118 | 177 | 399 | 592 | 243 | 436 |
| 71 " | 1689 × 633 | 124 | 183 | 405 | 597 | 247 | 439 |
| 72 " | 1712 × 642 | 131 | 190 | 411 | 603 | 250 | 442 |
| 73 " | 1736 × 651 | 137 | 196 | 416 | 608 | 253 | 446 |
| 74 " | 1760 × 660 | 144 | 203 | 422 | 614 | 257 | 449 |
| 75 " | 1784 × 669 | 150 | 209 | 427 | 619 | 260 | 452 |
| 76 " | 1807 × 678 | 157 | 215 | 433 | 625 | 263 | 456 |
| 77 " | 1831 × 687 | 163 | 222 | 438 | 631 | 267 | 459 |
| 78 " | 1855 × 696 | 169 | 228 | 444 | 636 | 270 | 462 |
| 79 " | 1879 × 705 | 176 | 235 | 450 | 642 | 273 | 466 |
| 80 " | 1903 × 713 | 182 | 241 | 455 | 647 | 277 | 469 |
| 81 " | 1926 × 722 | 189 | 248 | 461 | 653 | 280 | 472 |
| 82 " | 1950 × 731 | 195 | 254 | 466 | 658 | 283 | 476 |
| 83 " | 1974 × 740 | 202 | 261 | 472 | 664 | 287 | 479 |
| 84 " | 1998 × 749 | 208 | 267 | 477 | 670 | 290 | 482 |
| 85 " | 2022 × 758 | 215 | 274 | 483 | 675 | 293 | 486 |

| | S | a | b | c1 | d1 | c2 | d2 |
|-------|------------|-----|-----|-----|-----|-----|-----|
| 86 " | 2045 × 767 | 221 | 280 | 489 | 681 | 297 | 489 |
| 87 " | 2069 × 776 | 228 | 286 | 494 | 686 | 300 | 492 |
| 88 " | 2093 × 785 | 234 | 293 | 500 | 692 | 303 | 496 |
| 89 " | 2117 × 794 | 240 | 299 | 505 | 697 | 307 | 499 |
| 90 " | 2140 × 803 | 247 | 219 | 511 | 703 | 310 | 502 |
| 91 " | 2164 × 812 | 253 | 225 | 516 | 709 | 313 | 506 |
| 92 " | 2188 × 821 | 260 | 232 | 522 | 714 | 317 | 509 |
| 93 " | 2212 × 829 | 266 | 238 | 528 | 720 | 320 | 512 |
| 94 " | 2236 × 838 | 273 | 245 | 533 | 725 | 324 | 516 |
| 95 " | 2259 × 847 | 279 | 251 | 539 | 731 | 327 | 519 |
| 96 " | 2283 × 856 | 286 | 258 | 544 | 736 | 330 | 522 |
| 97 " | 2307 × 865 | 292 | 264 | 550 | 742 | 334 | 526 |
| 98 " | 2331 × 874 | 299 | 270 | 555 | 748 | 337 | 529 |
| 99 " | 2354 × 883 | 305 | 277 | 561 | 753 | 340 | 532 |
| 100 " | 2378 × 892 | 311 | 283 | 567 | 759 | 344 | 536 |
| 101 " | 2402 × 901 | 318 | 290 | 572 | 764 | 347 | 539 |
| 102 " | 2426 × 910 | 324 | 296 | 578 | 770 | 350 | 542 |
| 103 " | 2450 × 919 | 331 | 303 | 583 | 775 | 354 | 546 |
| 104 " | 2473 × 928 | 337 | 309 | 589 | 781 | 357 | 549 |
| 105 " | 2497 × 936 | 344 | 316 | 594 | 787 | 360 | 552 |
| 106 " | 2521 × 945 | 350 | 322 | 600 | 792 | 364 | 556 |
| 107 " | 2545 × 954 | 357 | 329 | 605 | 798 | 367 | 559 |
| 108 " | 2569 × 963 | 363 | 335 | 611 | 803 | 370 | 562 |
| 109 " | 2592 × 972 | 370 | 341 | 617 | 809 | 374 | 566 |
| 110 " | 2616 × 981 | 376 | 348 | 622 | 814 | 377 | 569 |

■ EB-725Wi

16:10 projected image

[Unit: mm]

| | S | a | b | c | d |
|------|-------------|-----|-----|-----|-----|
| 65 " | 1400 × 875 | 69 | 128 | 192 | 384 |
| 66 " | 1422 × 888 | 75 | 134 | 195 | 387 |
| 67 " | 1443 × 902 | 81 | 140 | 198 | 390 |
| 68 " | 1465 × 915 | 87 | 146 | 200 | 393 |
| 69 " | 1486 × 929 | 94 | 152 | 203 | 395 |
| 70 " | 1508 × 942 | 100 | 159 | 206 | 398 |
| 71 " | 1529 × 956 | 106 | 165 | 209 | 401 |
| 72 " | 1551 × 969 | 112 | 171 | 212 | 404 |
| 73 " | 1572 × 983 | 118 | 177 | 214 | 407 |
| 74 " | 1594 × 996 | 124 | 183 | 217 | 409 |
| 75 " | 1615 × 1010 | 131 | 190 | 220 | 412 |
| 76 " | 1637 × 1023 | 137 | 196 | 223 | 415 |
| 77 " | 1659 × 1037 | 143 | 202 | 226 | 418 |
| 78 " | 1680 × 1050 | 149 | 208 | 228 | 421 |
| 79 " | 1702 × 1063 | 155 | 214 | 231 | 423 |
| 80 " | 1723 × 1077 | 162 | 220 | 234 | 426 |
| 81 " | 1745 × 1090 | 168 | 227 | 237 | 429 |
| 82 " | 1766 × 1104 | 174 | 233 | 240 | 432 |
| 83 " | 1788 × 1117 | 180 | 239 | 242 | 435 |
| 84 " | 1809 × 1131 | 186 | 245 | 245 | 437 |
| 85 " | 1831 × 1144 | 192 | 251 | 248 | 440 |
| 86 " | 1852 × 1158 | 199 | 258 | 251 | 443 |
| 87 " | 1874 × 1171 | 205 | 264 | 254 | 446 |
| 88 " | 1895 × 1185 | 211 | 270 | 256 | 449 |
| 89 " | 1917 × 1198 | 217 | 276 | 259 | 451 |

| | S | a | b | c | d |
|-------|-------------|-----|-----|-----|-----|
| 90 " | 1939 × 1212 | 223 | 195 | 262 | 454 |
| 91 " | 1960 × 1225 | 230 | 201 | 265 | 457 |
| 92 " | 1982 × 1239 | 236 | 208 | 268 | 460 |
| 93 " | 2003 × 1252 | 242 | 214 | 271 | 463 |
| 94 " | 2025 × 1265 | 248 | 220 | 273 | 466 |
| 95 " | 2046 × 1279 | 254 | 226 | 276 | 468 |
| 96 " | 2068 × 1292 | 260 | 232 | 279 | 471 |
| 97 " | 2089 × 1306 | 267 | 238 | 282 | 474 |
| 98 " | 2111 × 1319 | 273 | 245 | 285 | 477 |
| 99 " | 2132 × 1333 | 279 | 251 | 287 | 480 |
| 100 " | 2154 × 1346 | 285 | 257 | 290 | 482 |

4:3 projected image

[Unit: mm]

| | S | a | b | c | d |
|------|-------------|-----|-----|-----|-----|
| 58 " | 1179 × 884 | 73 | 132 | 194 | 386 |
| 59 " | 1199 × 899 | 80 | 139 | 197 | 389 |
| 60 " | 1219 × 914 | 87 | 146 | 200 | 392 |
| 61 " | 1240 × 930 | 94 | 153 | 203 | 396 |
| 62 " | 1260 × 945 | 101 | 160 | 207 | 399 |
| 63 " | 1280 × 960 | 108 | 167 | 210 | 402 |
| 64 " | 1300 × 975 | 115 | 174 | 213 | 405 |
| 65 " | 1321 × 991 | 122 | 181 | 216 | 408 |
| 66 " | 1341 × 1006 | 129 | 188 | 219 | 411 |
| 67 " | 1361 × 1021 | 136 | 195 | 222 | 415 |
| 68 " | 1382 × 1036 | 143 | 202 | 226 | 418 |
| 69 " | 1402 × 1052 | 150 | 209 | 229 | 421 |
| 70 " | 1422 × 1067 | 157 | 216 | 232 | 424 |
| 71 " | 1443 × 1082 | 164 | 223 | 235 | 427 |
| 72 " | 1463 × 1097 | 171 | 230 | 238 | 430 |
| 73 " | 1483 × 1113 | 178 | 237 | 241 | 434 |
| 74 " | 1504 × 1128 | 185 | 244 | 245 | 437 |
| 75 " | 1524 × 1143 | 192 | 251 | 248 | 440 |
| 76 " | 1544 × 1158 | 199 | 258 | 251 | 443 |
| 77 " | 1565 × 1173 | 206 | 265 | 254 | 446 |
| 78 " | 1585 × 1189 | 213 | 272 | 257 | 450 |
| 79 " | 1605 × 1204 | 220 | 279 | 261 | 453 |

| | S | a | b | c | d |
|-------|-------------|-----|-----|-----|-----|
| 80 " | 1626 × 1219 | 227 | 286 | 264 | 456 |
| 81 " | 1646 × 1234 | 234 | 293 | 267 | 459 |
| 82 " | 1666 × 1250 | 241 | 300 | 270 | 462 |
| 83 " | 1687 × 1265 | 248 | 307 | 273 | 465 |
| 84 " | 1707 × 1280 | 255 | 314 | 276 | 469 |
| 85 " | 1727 × 1295 | 262 | 321 | 280 | 472 |
| 86 " | 1748 × 1311 | 269 | 328 | 283 | 475 |
| 87 " | 1768 × 1326 | 276 | 335 | 286 | 478 |
| 88 " | 1788 × 1341 | 283 | 342 | 289 | 481 |
| 89 " | 1808 × 1356 | 290 | 349 | 292 | 484 |
| 90 " | 1829 × 1372 | 297 | 356 | 295 | 488 |
| 91 " | 1849 × 1387 | 304 | 363 | 299 | 491 |
| 92 " | 1869 × 1402 | 311 | 370 | 302 | 494 |
| 93 " | 1890 × 1417 | 318 | 377 | 305 | 497 |
| 94 " | 1910 × 1433 | 325 | 384 | 308 | 500 |
| 95 " | 1930 × 1448 | 332 | 391 | 311 | 504 |
| 96 " | 1951 × 1463 | 339 | 398 | 314 | 507 |
| 97 " | 1971 × 1478 | 346 | 405 | 318 | 510 |
| 98 " | 1991 × 1494 | 353 | 412 | 321 | 513 |
| 99 " | 2012 × 1509 | 360 | 419 | 324 | 516 |
| 100 " | 2032 × 1524 | 367 | 426 | 327 | 519 |

16:9 projected image

[Unit: mm]

| | S | a | b | c | d |
|------|-------------|-----|-----|-----|-----|
| 64 " | 1417 × 797 | 74 | 133 | 238 | 431 |
| 65 " | 1439 × 809 | 80 | 139 | 242 | 434 |
| 66 " | 1461 × 822 | 86 | 145 | 246 | 438 |
| 67 " | 1483 × 834 | 93 | 152 | 249 | 441 |
| 68 " | 1505 × 847 | 99 | 158 | 253 | 445 |
| 69 " | 1528 × 859 | 105 | 164 | 256 | 448 |
| 70 " | 1550 × 872 | 112 | 171 | 260 | 452 |
| 71 " | 1572 × 884 | 118 | 177 | 263 | 456 |
| 72 " | 1594 × 897 | 125 | 183 | 267 | 459 |
| 73 " | 1616 × 909 | 131 | 190 | 271 | 463 |
| 74 " | 1638 × 921 | 137 | 196 | 274 | 466 |
| 75 " | 1660 × 934 | 144 | 202 | 278 | 470 |
| 76 " | 1682 × 946 | 150 | 209 | 281 | 474 |
| 77 " | 1705 × 959 | 156 | 215 | 285 | 477 |
| 78 " | 1727 × 971 | 163 | 221 | 288 | 481 |
| 79 " | 1749 × 984 | 169 | 228 | 292 | 484 |
| 80 " | 1771 × 996 | 175 | 234 | 296 | 488 |
| 81 " | 1793 × 1009 | 182 | 241 | 299 | 491 |
| 82 " | 1815 × 1021 | 188 | 247 | 303 | 495 |
| 83 " | 1837 × 1034 | 194 | 253 | 306 | 499 |
| 84 " | 1860 × 1046 | 201 | 260 | 310 | 502 |
| 85 " | 1882 × 1058 | 207 | 266 | 313 | 506 |
| 86 " | 1904 × 1071 | 213 | 272 | 317 | 509 |
| 87 " | 1926 × 1083 | 220 | 279 | 321 | 513 |
| 88 " | 1948 × 1096 | 226 | 285 | 324 | 516 |
| 89 " | 1970 × 1108 | 232 | 291 | 328 | 520 |

| | S | a | b | c | d |
|-------|-------------|-----|-----|-----|-----|
| 90 " | 1992 × 1121 | 239 | 211 | 331 | 524 |
| 91 " | 2015 × 1133 | 245 | 217 | 335 | 527 |
| 92 " | 2037 × 1146 | 252 | 223 | 339 | 531 |
| 93 " | 2059 × 1158 | 258 | 230 | 342 | 534 |
| 94 " | 2081 × 1171 | 264 | 236 | 346 | 538 |
| 95 " | 2103 × 1183 | 271 | 242 | 349 | 541 |
| 96 " | 2125 × 1195 | 277 | 249 | 353 | 545 |
| 97 " | 2147 × 1208 | 283 | 255 | 356 | 549 |
| 98 " | 2170 × 1220 | 290 | 262 | 360 | 552 |
| 99 " | 2192 × 1233 | 296 | 268 | 364 | 556 |
| 100 " | 2214 × 1245 | 302 | 274 | 367 | 559 |

■ Attaching the adjustment unit to the projector

1

Loosen the M4 bolt on the adjustment unit, and then align the marks for each part

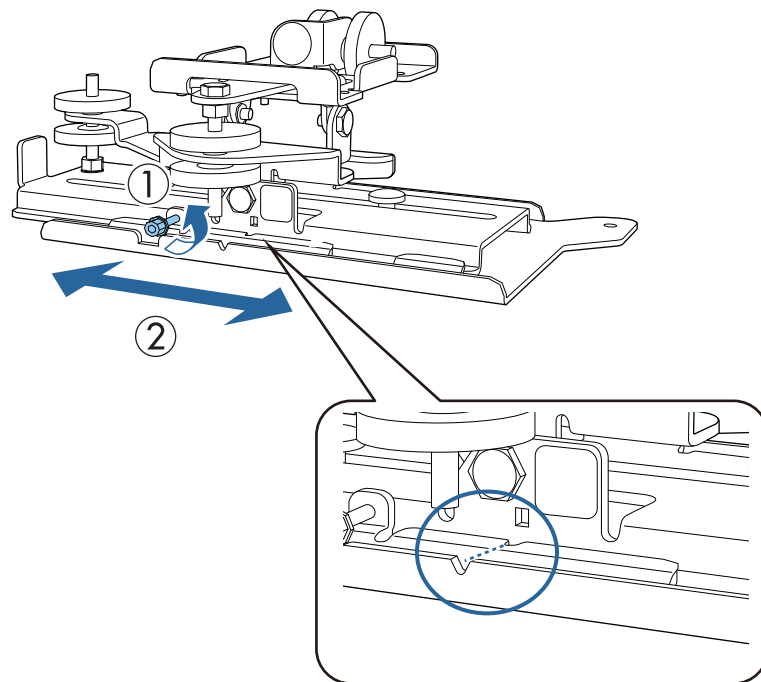

When the position is correct, tighten the M4 bolt.

- Secure the adjustment unit to the base of the projector with the M4 x 12 mm bolts (x4) supplied

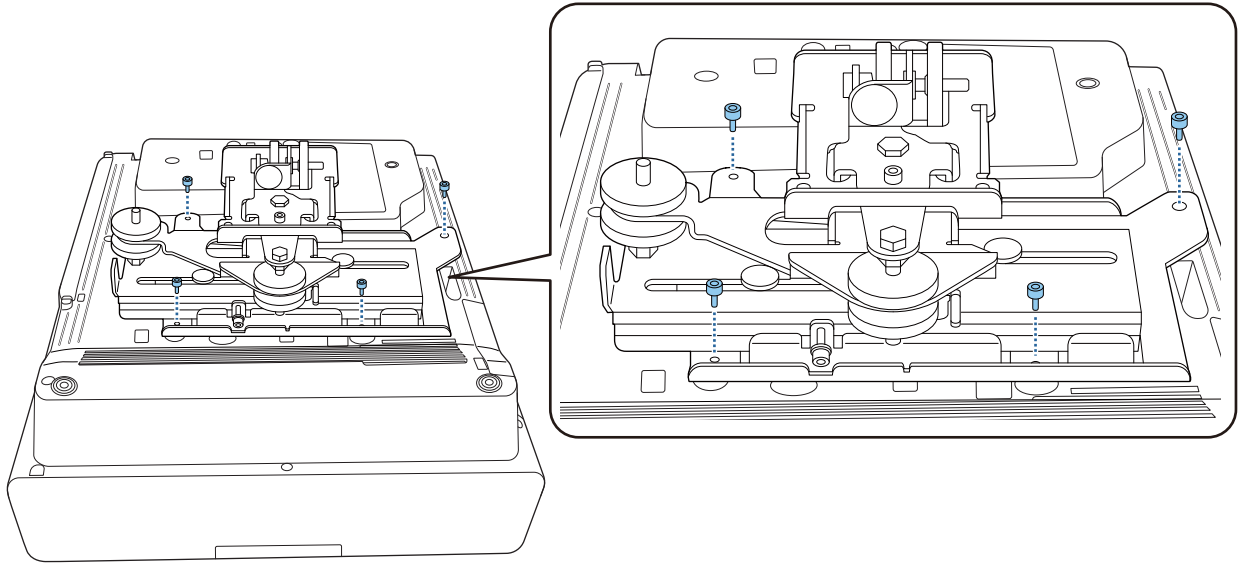

- Install the wall plate on the wall

- Attach the template sheet to the wall

Attach the template sheet according to the installation position that you confirmed using the projection distance table (p.28).

Align the center position of the screen being projected with Image Center B on the Template sheet.

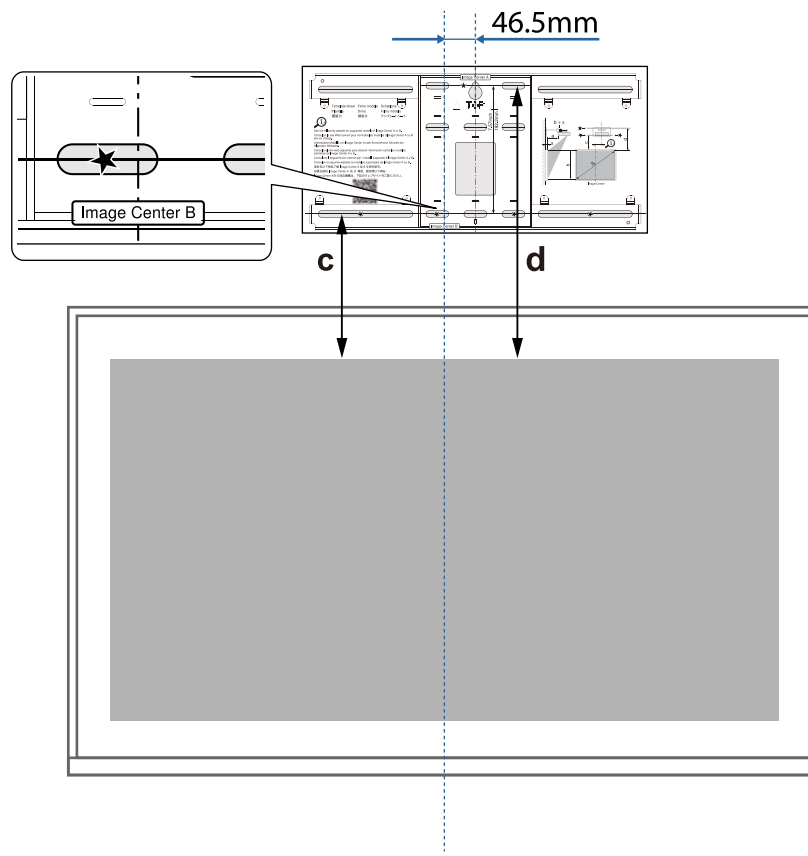

2 Drive a commercially available M10 screw into the position of the temporary screw hole for the wall plate

Leave a gap of 6 mm or more between the wall and the screw head.

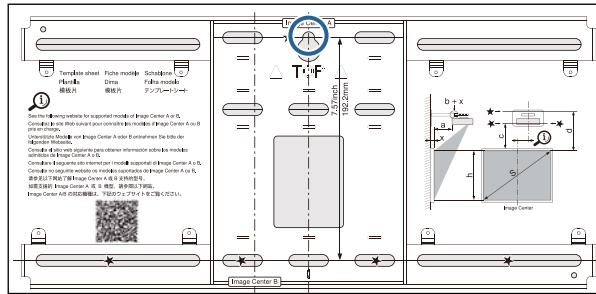

3 Determine the positions for the mounting holes for the wall plate

From the screw holes shown in the figure below, secure at least four points for optimum balance.

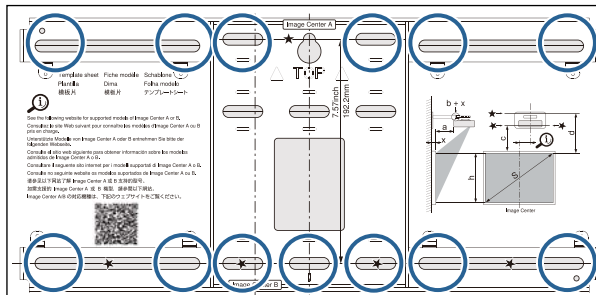

4 Drill the holes in the wall

Drill diameter: 10.5 mm (M10) or 10 mm (3/8 inches)

Pilot hole depth: 45 mm

Anchor hole depth: 40 mm

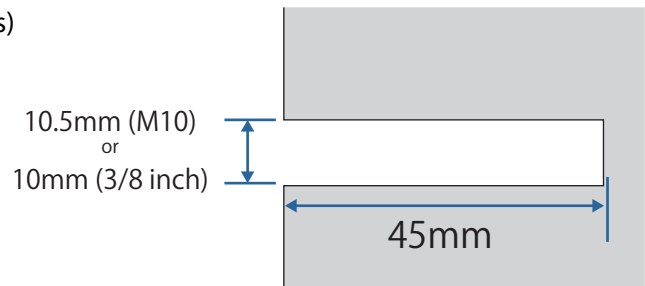

5 Remove the template sheet

6 Place the wall plate on the temporary M10 screw that you installed in step 2

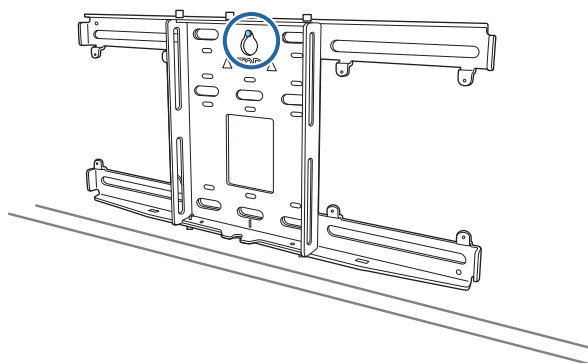

- 7** Use commercially available M10 or 3/8 inch x 60 mm anchor bolts to secure the wall plate to the holes you drilled in step 4

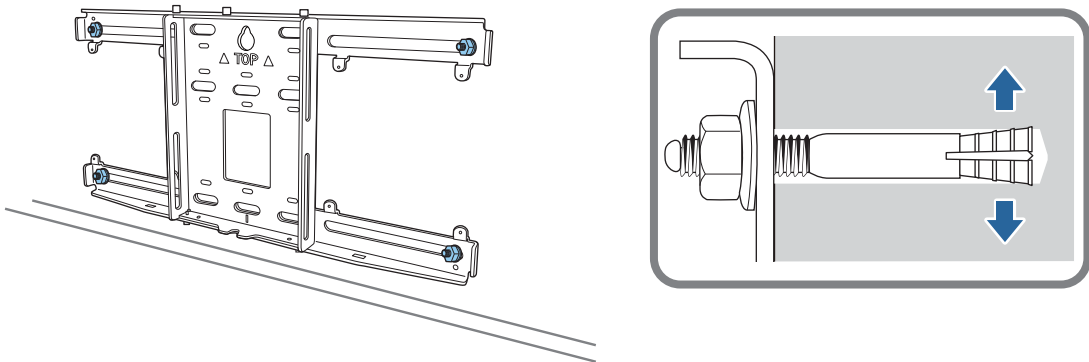

■ Attaching the setting plate to the wall plate

- 1** Loosen the M4 x 12 mm bolts (x2) and extend the arm slide on the setting plate
Adjust the scale on the slider to the combined distance of the value for (b) confirmed in the projection distance table (p.28) and the thickness of the projection surface (x).

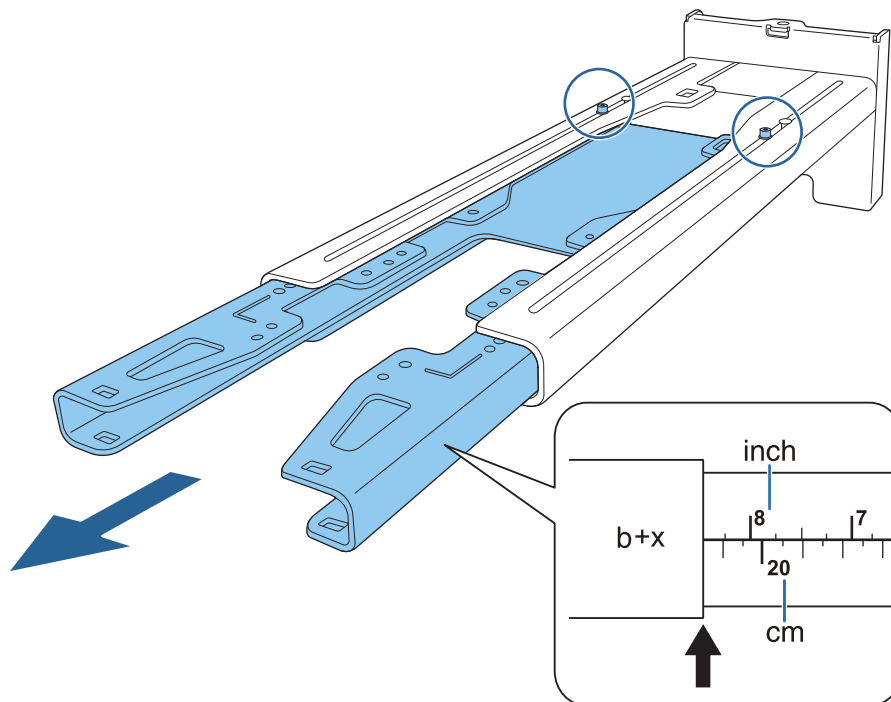

2 Insert the hexagonal axis into the setting plate

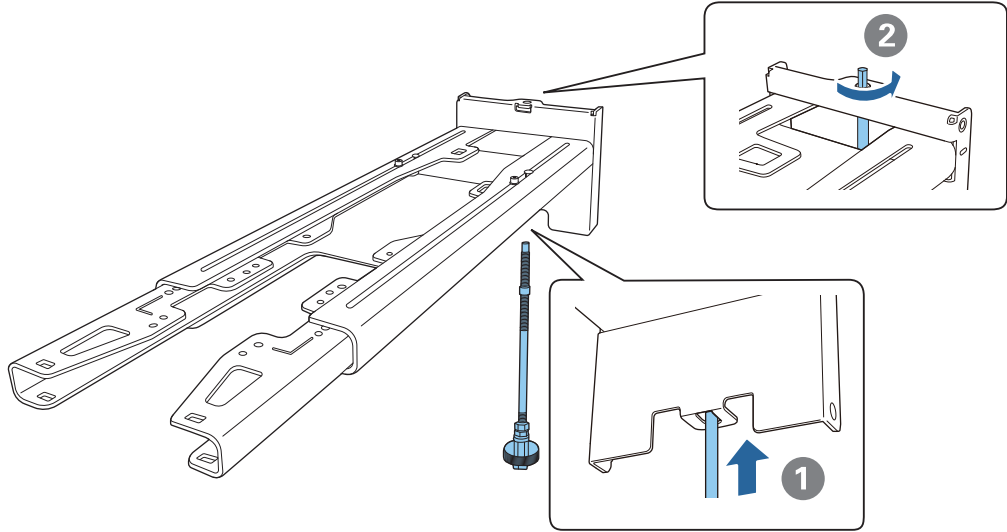

3 Route the necessary cables through the setting plate

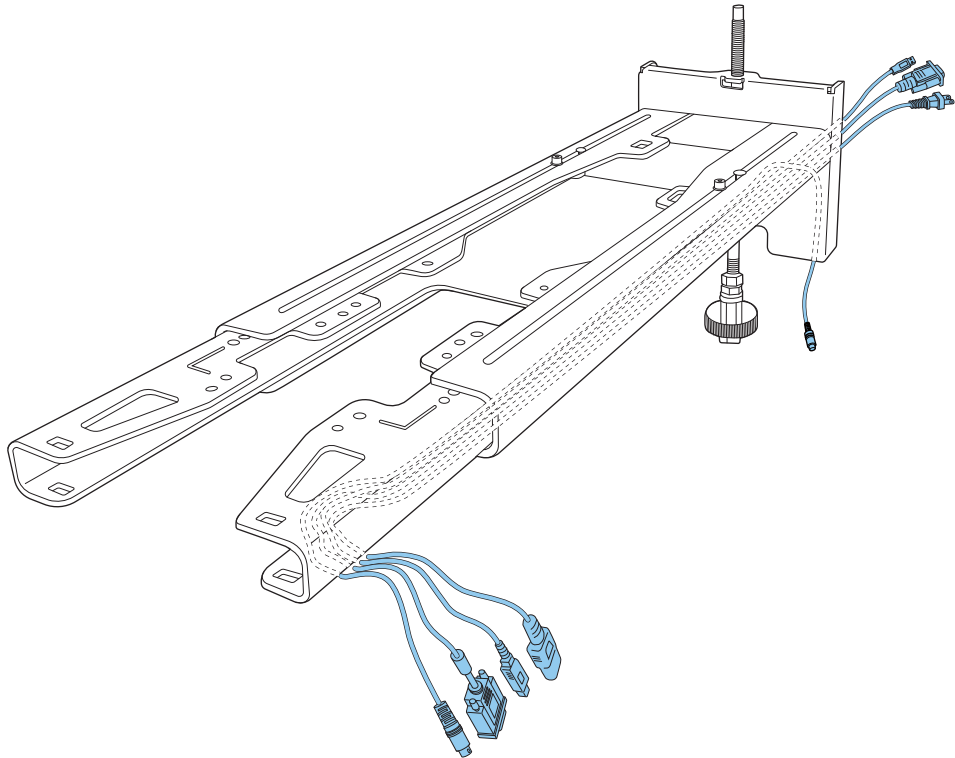

 **Warning**

Do not hang the rest of the cable over the setting plate. They could fall and cause an accident.



The following connection ports should be routed so that they come out of the lower part of the setting plate and not through walls.

- Cable for connecting to the Touch Unit
- Cables for connecting to peripheral devices such as mini-PCs

- 4** Attach the setting plate to the wall plate
Insert the hexagonal axis until the tip extends slightly out of the top of the wall plate and the other end connects to the bottom of the wall plate.

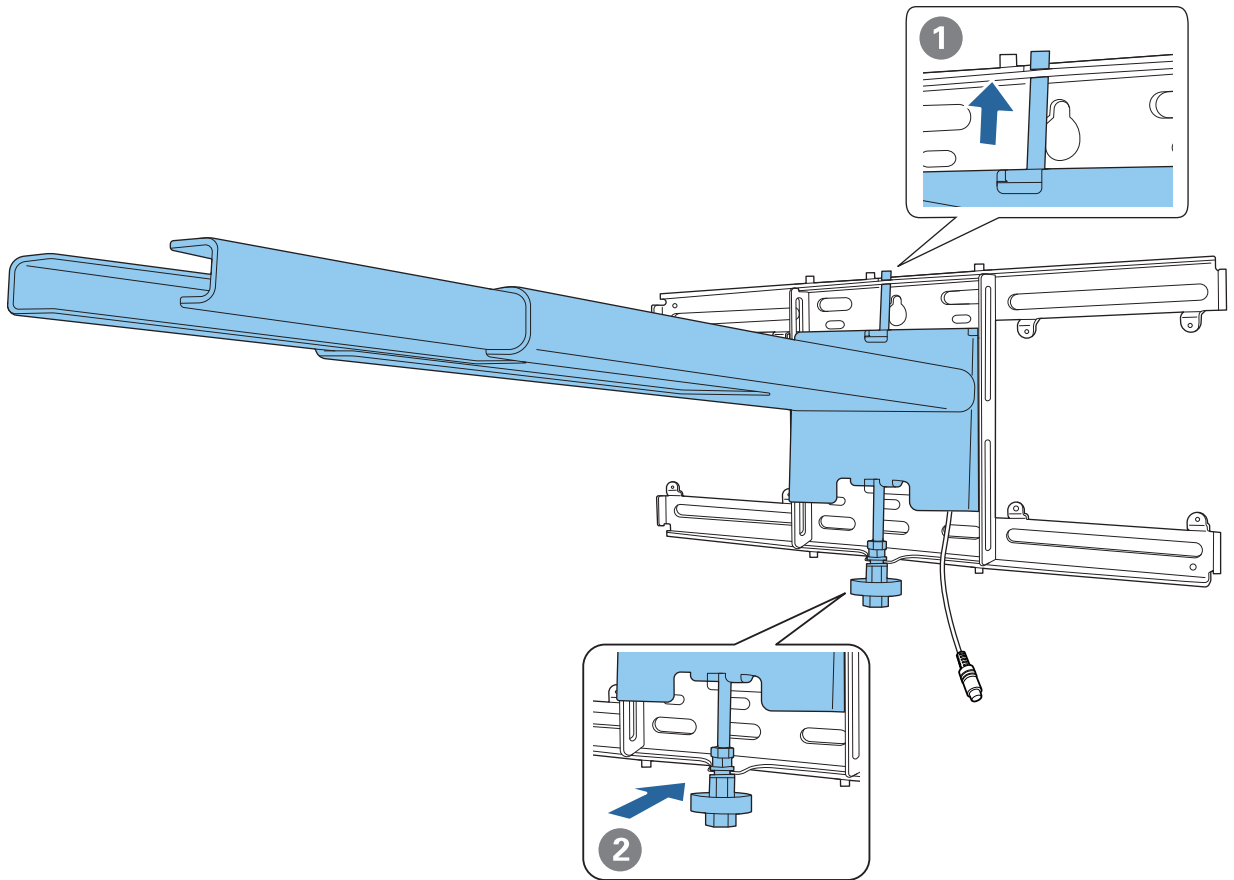

! Caution

Take care not to trap the cables between the setting plate and wall plate.

5

Temporarily secure the setting plate

Secure three points with the M6 screws supplied (x3).

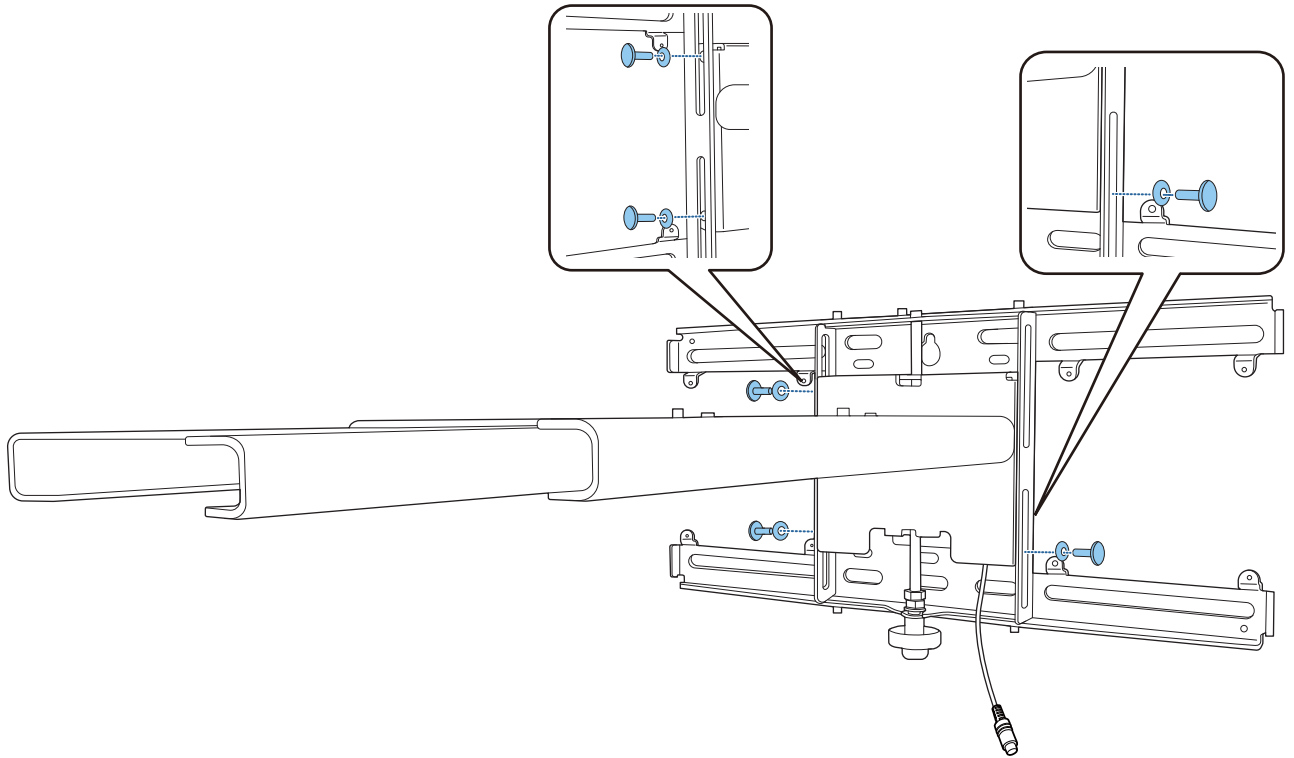

6

Rotate the bottom of the hexagonal axis with a 17 mm ratchet wrench to align the marks on the wall plate and the setting plate

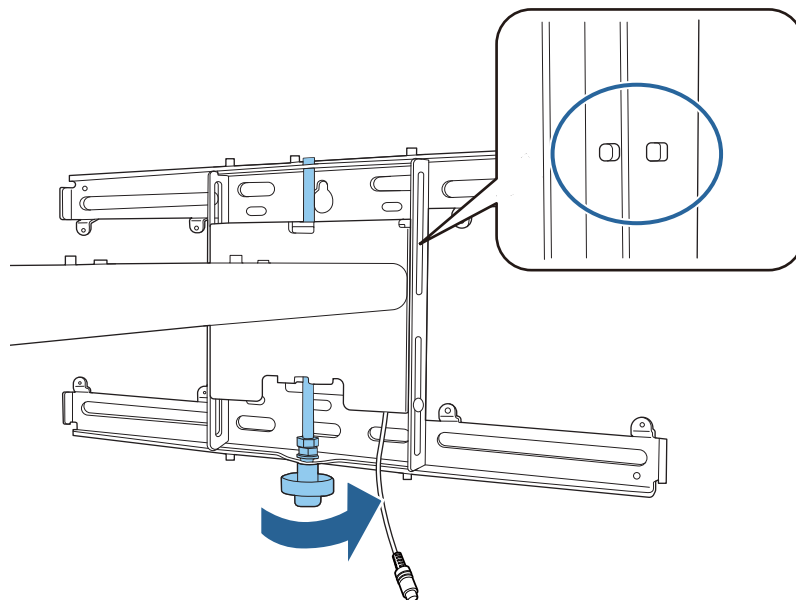

- 7 Tighten the M6 bolt (x1) to secure the setting plate in position

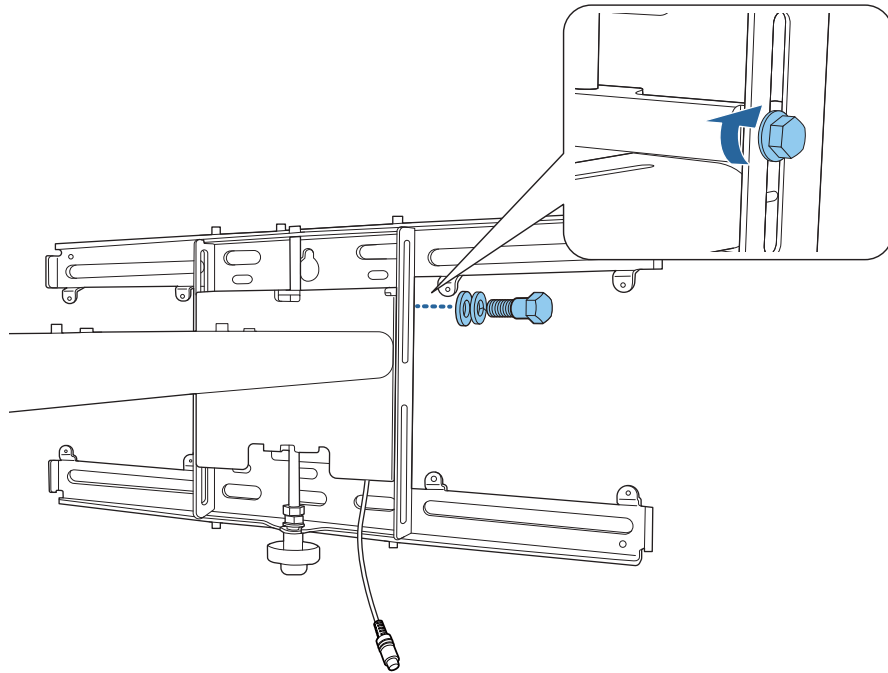

■ Attaching the adjustment unit to the setting plate

- 1 Check the installation position for the adjustment unit
The installation position is marked on the setting plate. Install at an appropriate position according to the size of the screen you want to project on to.

- When a projected image is smaller than 90 inches: Install the unit at the ○ mark.

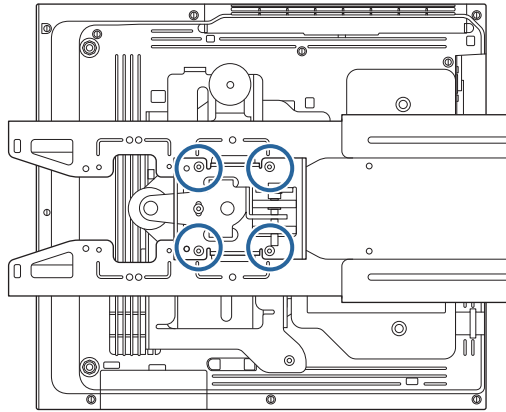

- When a projected image is 90 inches or more: Install the unit at the ○ ○ mark.

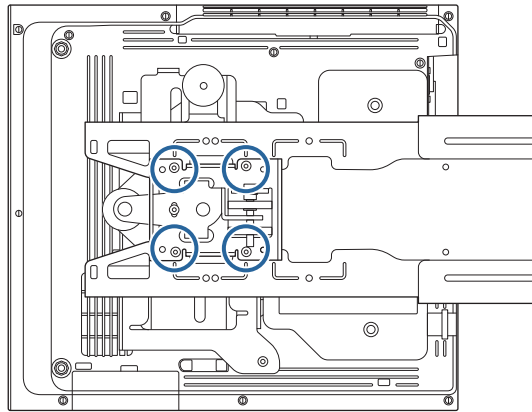

2 Attach the adjustment unit to the setting plate with the M4 x 12 mm bolts (x4) supplied

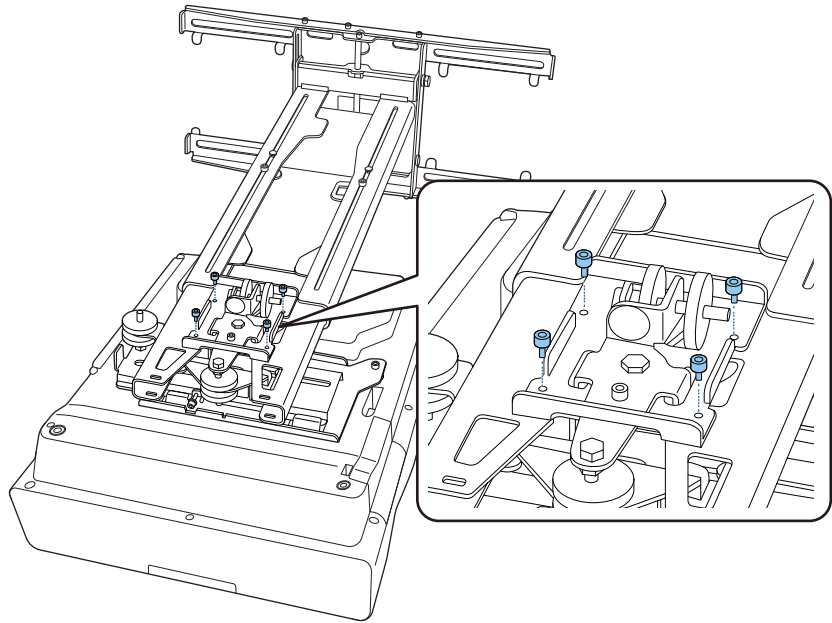

3 Connect the cables to the projector
Connect the power cord last.

Attaching peripheral devices

Attaching a switcher or a tuner

Use commercially available M4 screws to secure a switcher or a tuner to the screw holes as shown in the following figure.

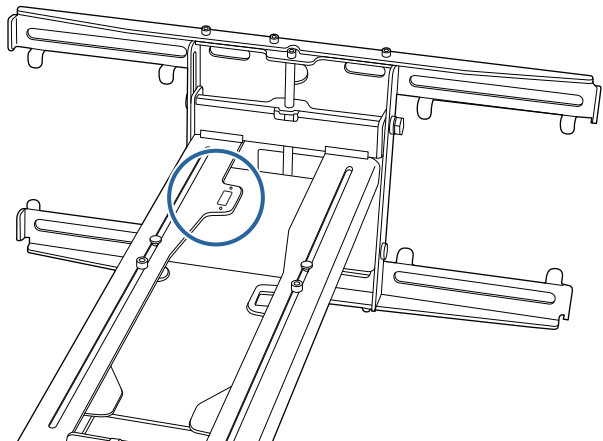

Attaching a mini PC or stick PC

Attach the mini PC or stick PC to the mini PC plate, and secure it to the left or right side of the wall plate.

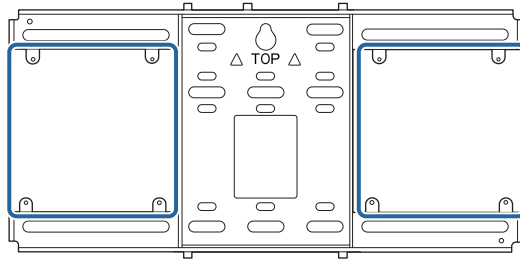

Attach it so that the air exhaust vents of the PC are not blocked.

We recommend installing the PC so that the air exhaust vents are at the top and the air intake vents are at the bottom.

When securing with the mini PC belt

1

Wrap the belt around the mini PC plate

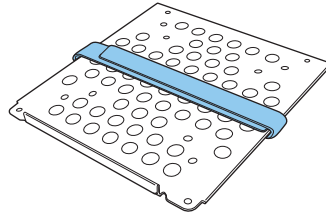

2

Secure the mini PC plate to the wall plate using the M3 x 6 mm screws (x4) supplied.

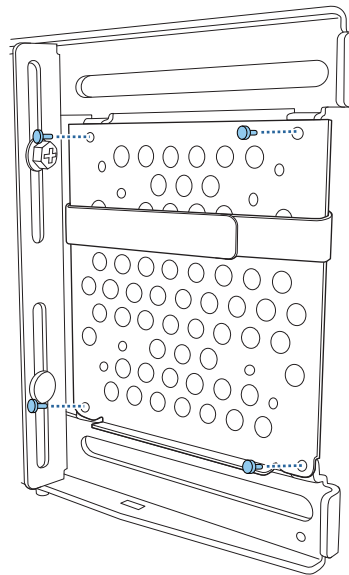

3

Place the PC on the lower edge of the mini PC plate, and secure it with the belt

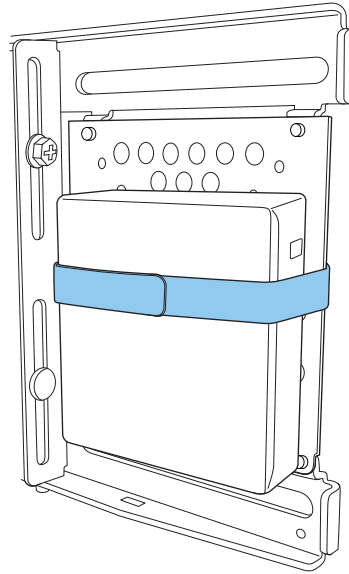

When securing with screws

Depending on the shape of the mini PC and the orientation of the screw holes, the order in which parts are installed differs. Be sure to check the installation instructions in advance.

Installation example

- Secure the mini PC plate with the PC installed to the wall plate using the M3 x 6 mm screws (x4) supplied.

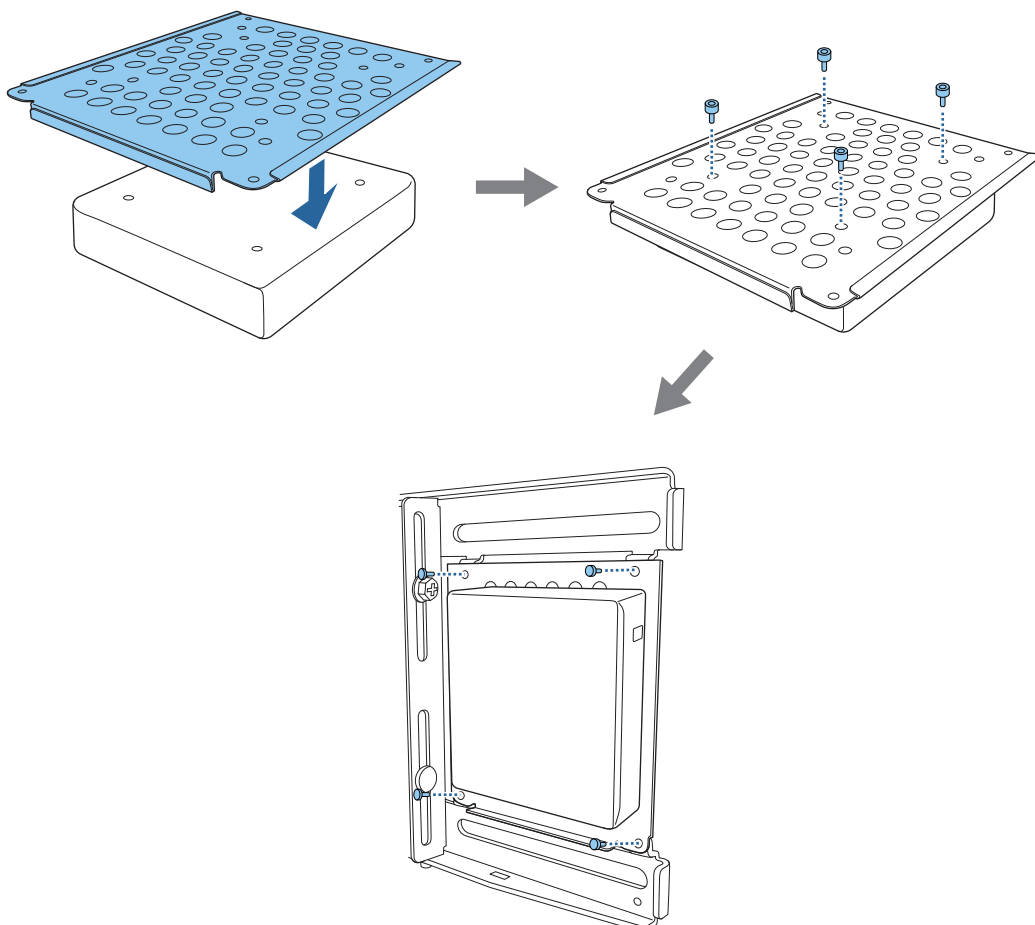

- Secure the mini PC plate to the wall plate using the M3 x 6 mm screws (x4) supplied, and then install the PC.

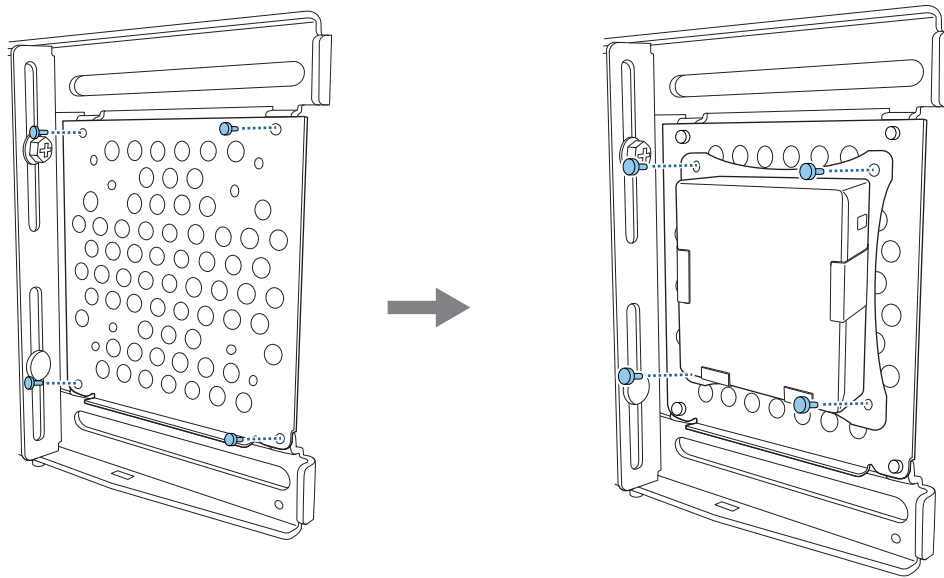

Adjusting the Position of the Projected Image

You can use any of the following methods to adjust the position of the projected image.



When multiple projectors are installed in the same room, we recommend that you set projector IDs to prevent remote control interference.

Turn on a projector and set the ID number for the projector in **Installation > Projector ID**.

When you want to operate a specific projector, hold down the [ID] button on the remote control and press the button with the same number as the projector ID.

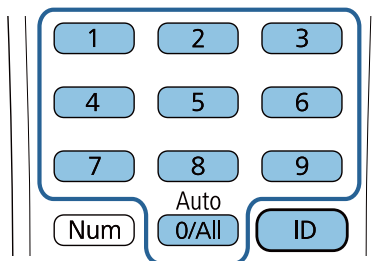

- Auto Screen Adjustment ([p.58](#))

Attach corner markers to the four corners of the projection position to automatically adjust the position of the image. This is useful when you want to perform an approximate adjustment to a specific position.

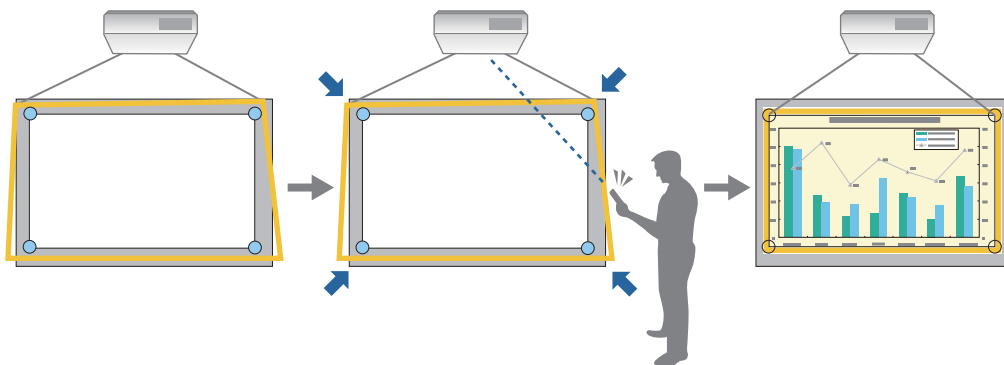

- Adjusting using the Setting Plate Installation Guide ([p.62](#))

Manually adjust the position of the setting plate according to the guide screen displayed. This is useful when you want to perform fine adjustments to the projection position while maintaining the image quality.

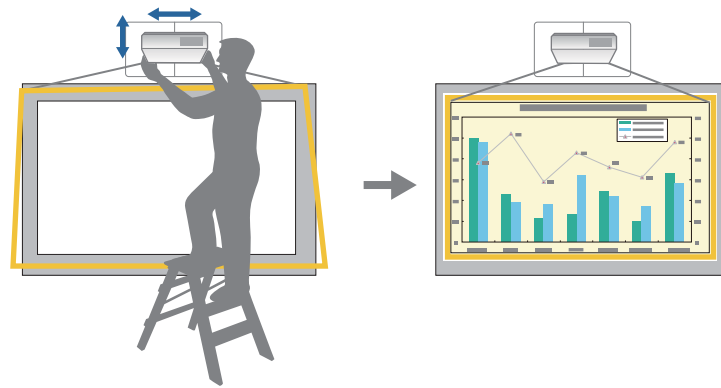

- Adjusting using the projector menus (p.65)

Select the area you want to adjust and manually correct the image. This is useful when you want to make fine adjustments to the projection position after making mechanical adjustments using the guide screen.

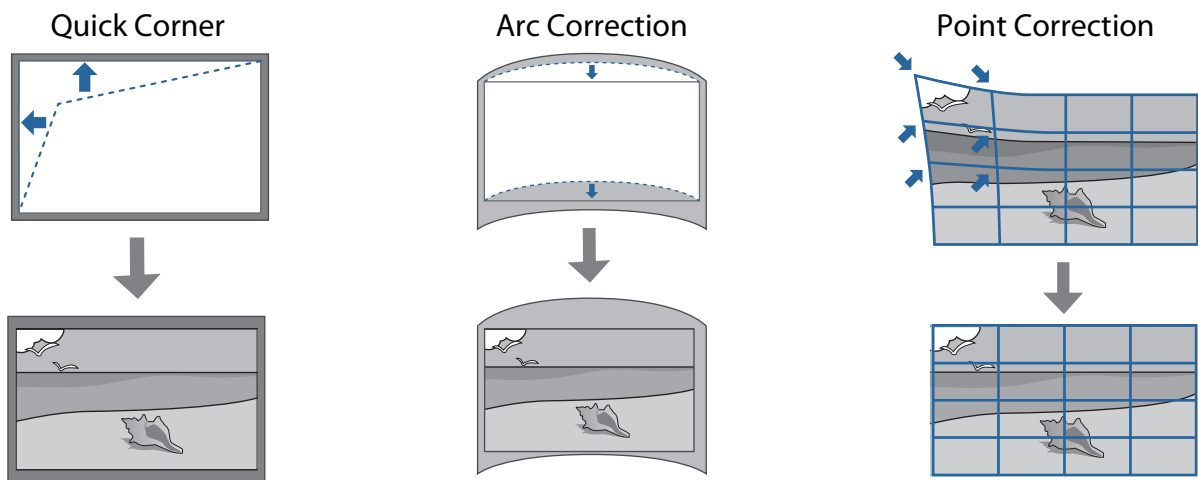

- Images are not stable immediately after turning on the projector. After starting projection, wait for at least 30 minutes before adjusting the image.
- Install and adjust the projector at a room temperature that is close to the actual intended usage environment. If the temperature changes, the position of the image may shift or the accuracy of the pen may decline.
- When setting up multiple projectors using the batch setup function, perform the batch setup before adjusting the projected image.
- We recommend the mechanical position adjustment of the setting plate to adjust the image when you want to maintain image quality.

■ Preparations before adjusting

- 1 Press the [⏻] button on the remote control or the control panel to turn on the projector

2 Open the air filter cover on the side of the projector

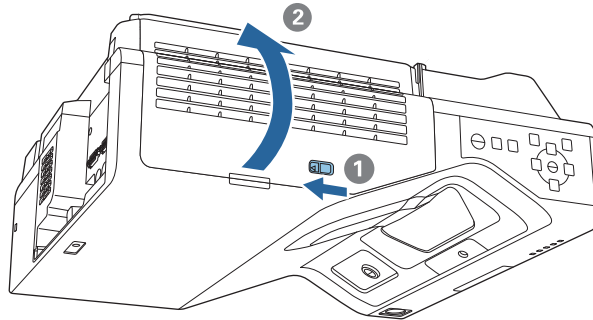

3 Use the focus lever to approximately focus the image

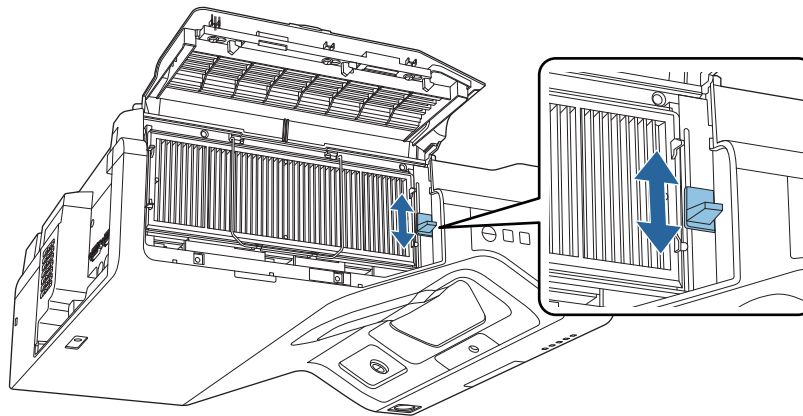

4 Press the [Menu] button

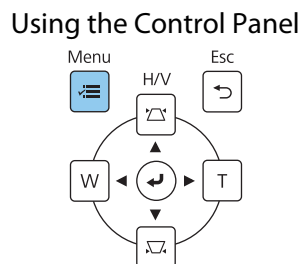
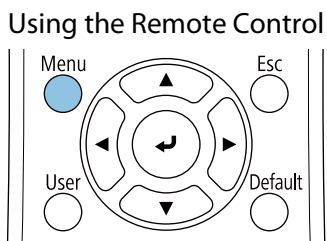

5 Select **Screen Type** from the **Installation** menu to set the aspect ratio of the projected image

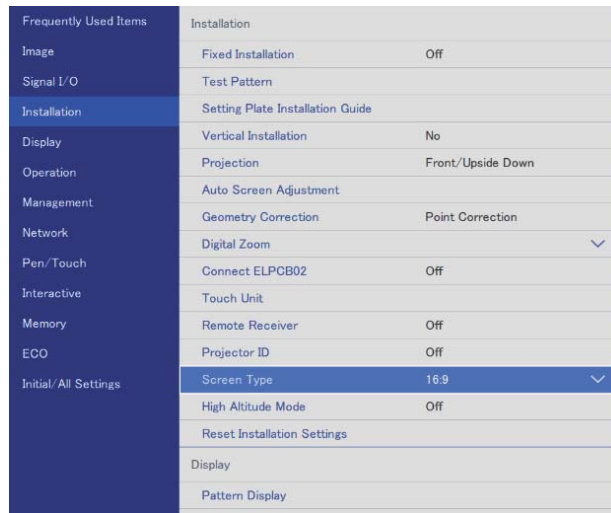

6 Change the aspect ratio if necessary
Project images from a connected device, and then press the [Aspect] button on the remote control. Each time you press the button, you see the aspect name on the screen and the aspect ratio changes.



The aspect ratio does not change when no images are being projected from the connected device.

Auto Screen Adjustment

Attach corner markers to the four corners of the projection position to automatically adjust the position of the image.

Auto Screen Adjustment works correctly under the following conditions.

- Projection size: 100 inches or less
- Projector direction: Within 1° up, down, left, or right



- Auto Screen Adjustment may not work properly depending on the surface of the projected screen. The following conditions are necessary to perform Auto Screen Adjustment.
 - A flat projection surface
 - No patterns, dirt, or obstacles on the projection surface
- Before performing the Auto Screen Adjustment, set the Screen Type setting first. If you change the Screen Type after performing Auto Screen Adjustment, the adjustments will be reset.

1

Place the corner markers at the four corners of the position you want to project to



- Corner markers cannot be placed again. We recommend marking the position where you want to place the markers in advance.
- If you want to replace markers repeatedly, stick them onto the magnetic sheet supplied.

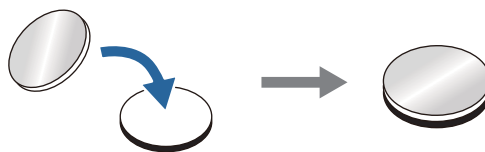

Place the markers so that the corners of the projection position overlap with the center of the corner markers.

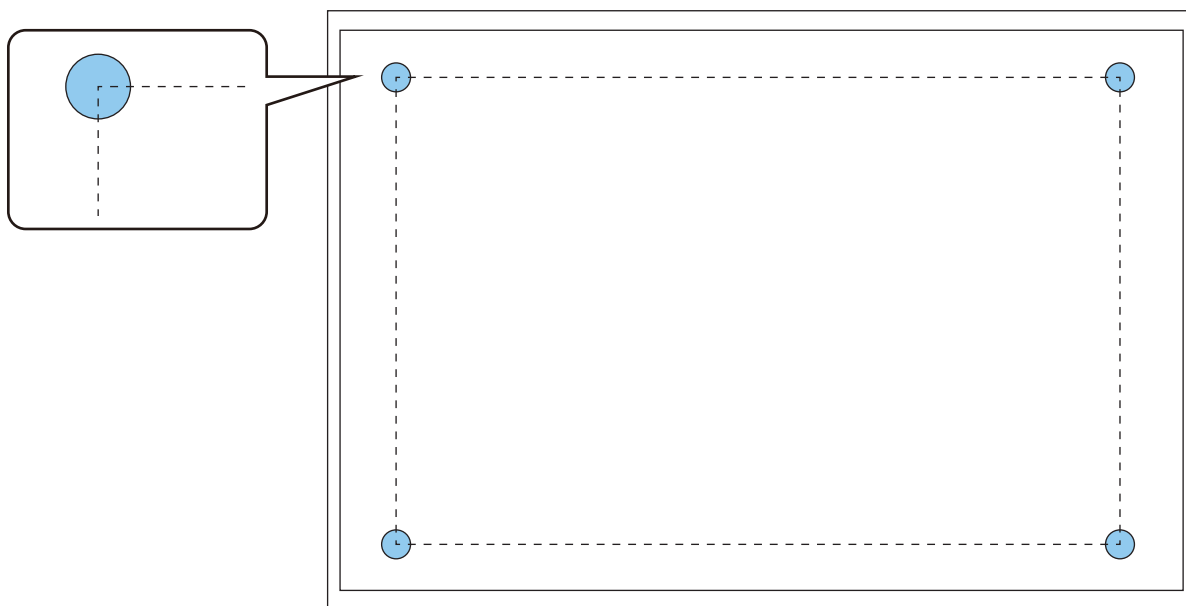

2

Press the [Menu] button

Using the Remote Control

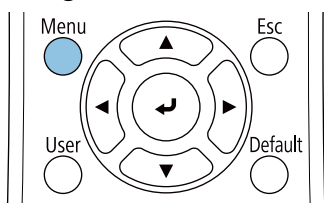

Using the Control Panel

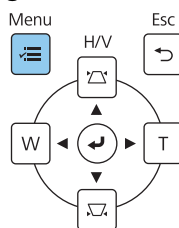

3

Select **Auto Screen Adjustment** from the **Installation** menu

| | | |
|-----------------------|----------------------------------|-------------------|
| Frequently Used Items | Installation | |
| Image | Fixed Installation | Off |
| Signal I/O | Test Pattern | |
| Installation | Setting Plate Installation Guide | |
| Display | Vertical Installation | No |
| Operation | Projection | Front/Upside Down |
| Management | Auto Screen Adjustment | |
| Network | Geometry Correction | Point Correction |
| Pen/Touch | Digital Zoom | ▼ |
| Interactive | Connect ELPCB02 | Off |
| Memory | Touch Unit | |
| ECO | Remote Receiver | Off |
| Initial/All Settings | Projector ID | Off |
| | Screen Type | 16:9 ▼ |
| | High Altitude Mode | Off |
| | Reset Installation Settings | |
| | Display | |
| | Pattern Display | |

You see the guidance screen for Auto Screen Adjustment.

4

Loosen all of the adjustment dials and adjustment screws

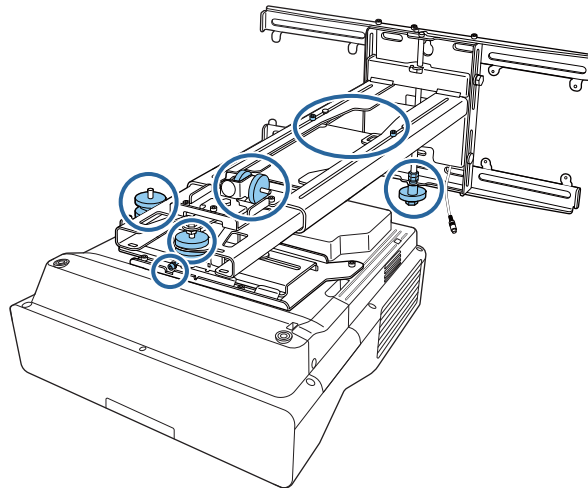

5

Move the projector to adjust the position of the image so that the yellow areas at the four corners of the guidance screen overlap with the corner markers

Make sure that all of the corner markers are within the yellow areas.

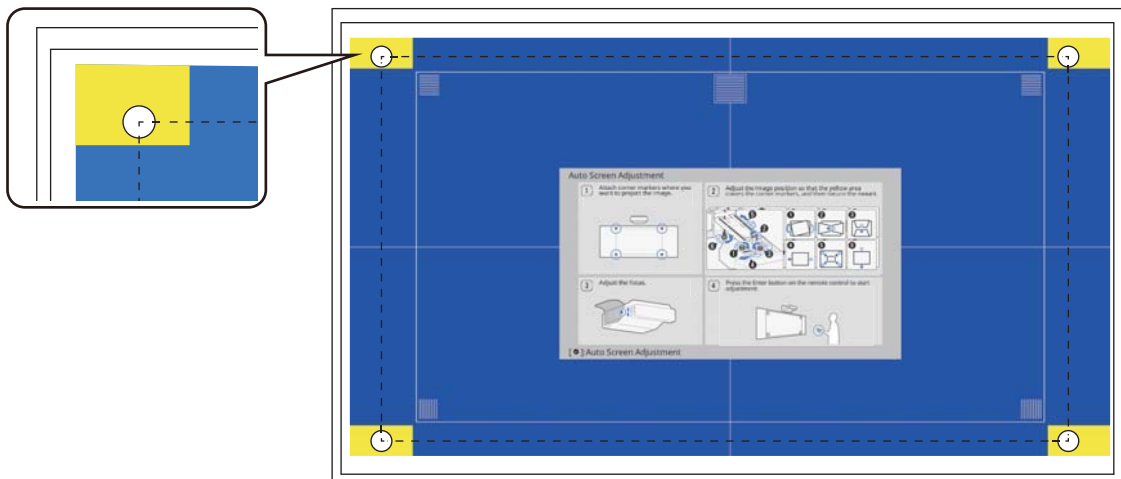

- 6 When you determine the position, tighten all of the adjustment dials and adjustment screws that you loosened in step 4

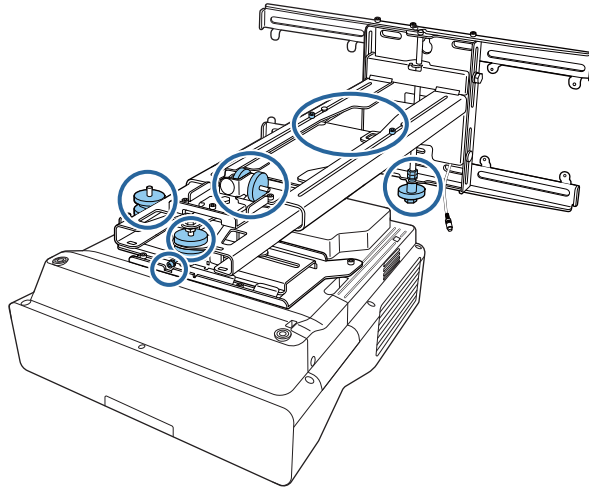

 **Warning**

Tighten all bolts and screws firmly. Otherwise, the product may fall and cause personal injury or property damage.

- 7 Open the air filter cover on the side of the projector

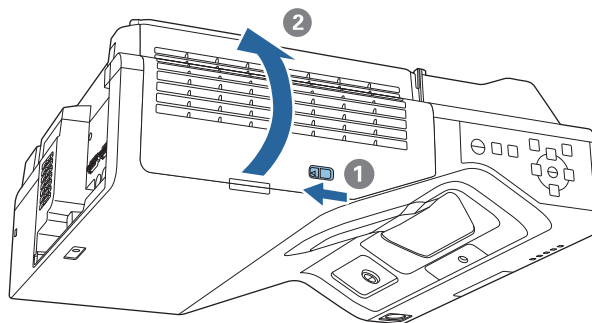

- 8 Use the focus lever to approximately focus the image

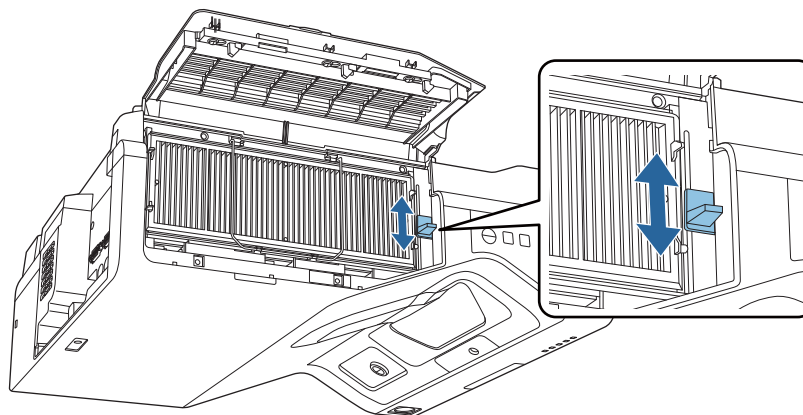

9 Press the [Enter] button to start auto adjustment

When auto adjustment is complete, use Quick Corner (p.67) to make further adjustments. Using Arc Correction or Point Correction returns the image to the status before auto correction was performed.

■ Performing mechanical adjustment using the Setting Plate Installation Guide

Use the guidance screen to adjust the position of the image.

1 Press the [Menu] button

Using the Remote Control

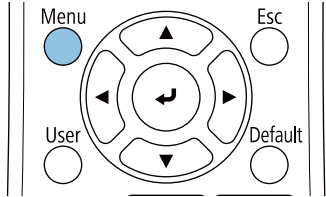

Using the Control Panel

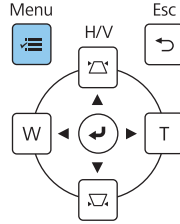

2 Select **Setting Plate Installation Guide** from the **Installation** menu

| | | |
|-----------------------|----------------------------------|-------------------|
| Frequently Used Items | Installation | |
| Image | Fixed Installation | Off |
| Signal I/O | Test Pattern | |
| Installation | Setting Plate Installation Guide | |
| Display | Vertical Installation | No |
| Operation | Projection | Front/Upside Down |
| Management | Auto Screen Adjustment | |
| Network | Geometry Correction | Point Correction |
| Pen/Touch | Digital Zoom | |
| Interactive | Connect ELPCB02 | Off |
| Memory | Touch Unit | |
| ECO | Remote Receiver | Off |
| Initial/All Settings | Projector ID | Off |
| | Screen Type | 16:9 |
| | High Altitude Mode | Off |
| | Reset Installation Settings | |
| | Display | |
| | Pattern Display | |

You see the guidance screen.

3 Turn the adjustment dial **1** in the installation guide to adjust the horizontal roll

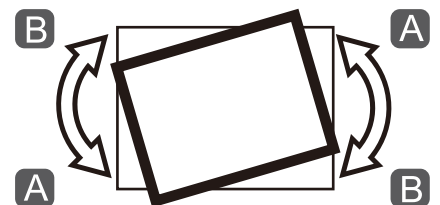
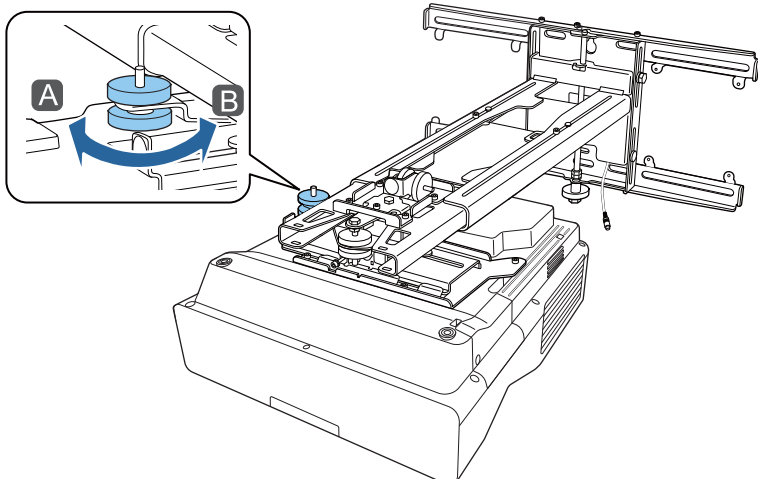

4 Turn the adjustment dial ② in the installation guide to adjust the horizontal rotation

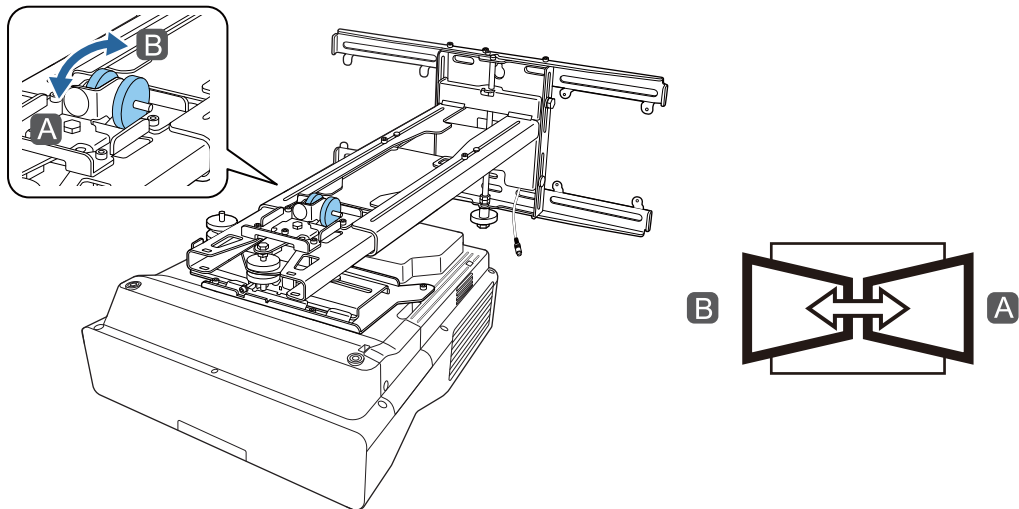

5 Turn the adjustment dial ③ in the installation guide to adjust the vertical tilt

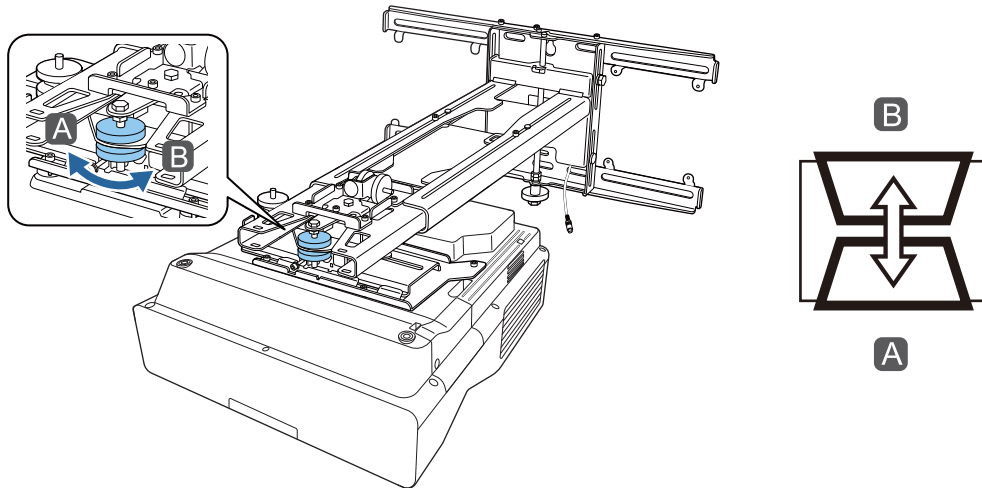

6 Loosen the M4 bolt, and then adjust the horizontal slide

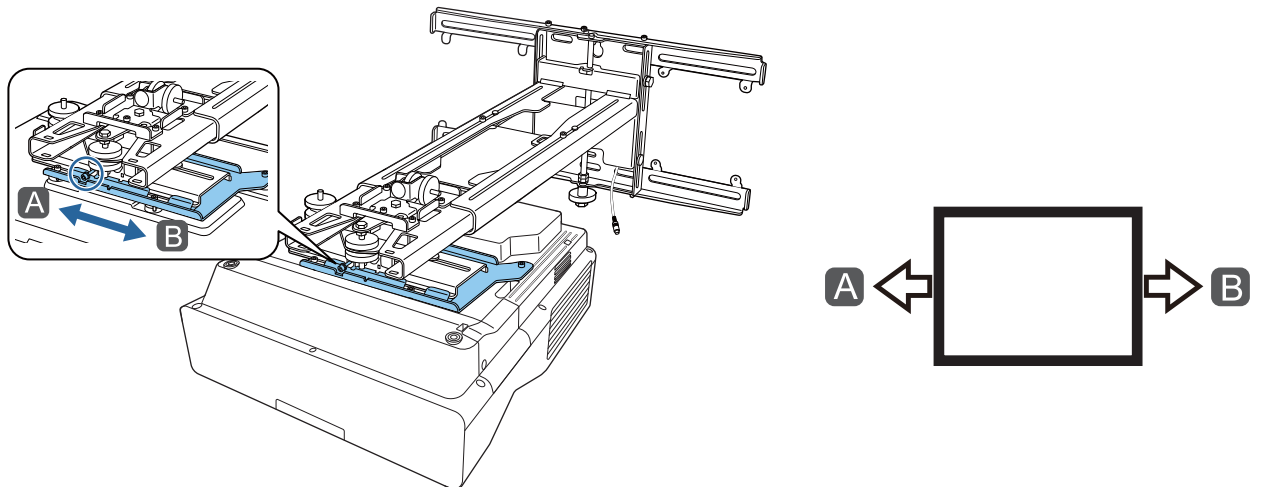

7 Loosen the M4 bolts (x2), and then adjust the forward/backward slide

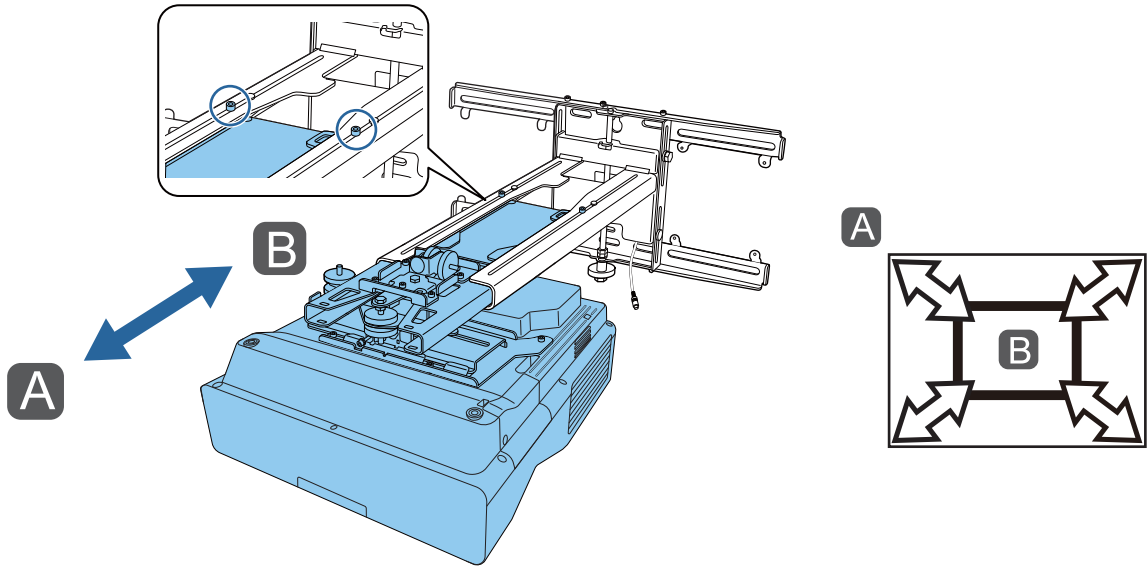

8 Loosen the M6 bolt, and then adjust the vertical slide

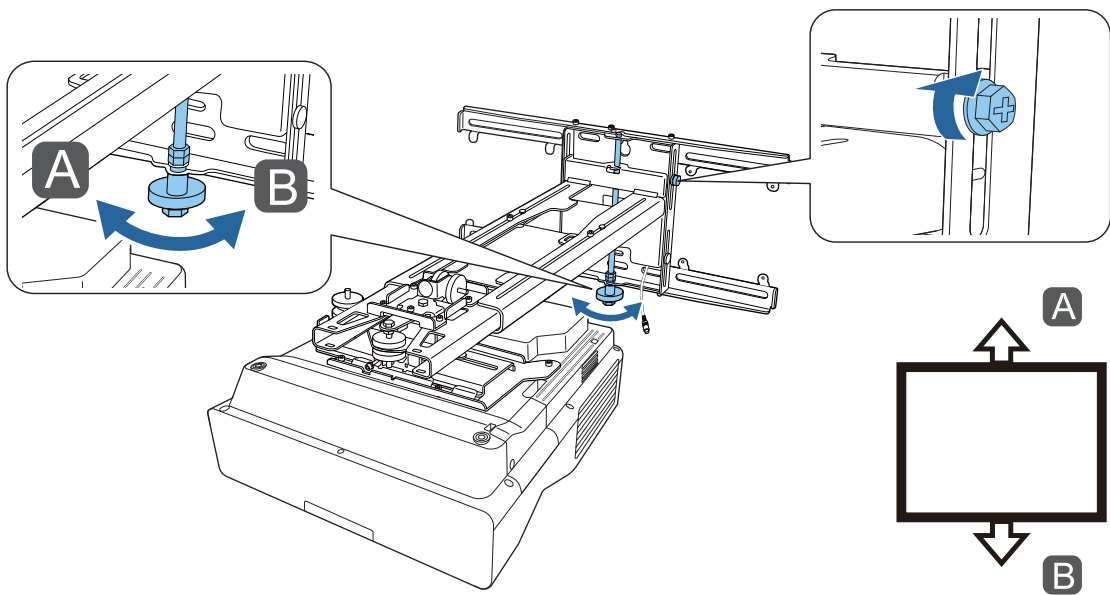

9 Re-tighten the screws and bolts that you loosened in steps 3 to 8

 **Warning**

Tighten all bolts and screws firmly. Otherwise, the product may fall and cause personal injury or property damage.

10

Adjust the focus of position A in the following figure

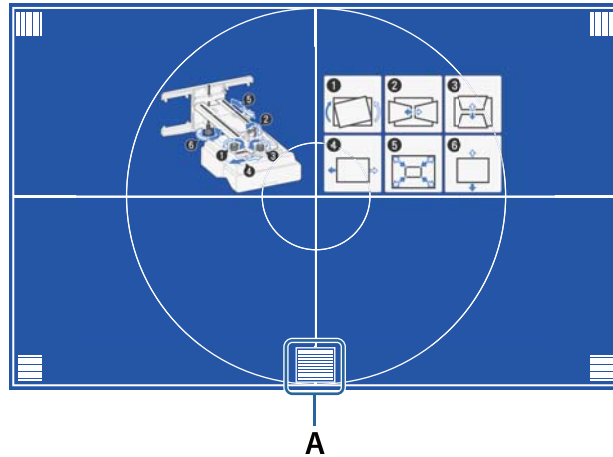

11

When you have finished making adjustments, press the [Esc] button on the remote control or the control panel to exit the guidance screen

Adjusting using the projector menus



- You can save adjusted values in **Memory** from the **Geometry Correction** menu.
- Before performing the adjustment, set the Screen Type setting first. If you change the Screen Type after making corrections, the corrections will be reset.

Arc Correction

1

Press the [Menu] button

Using the Remote Control

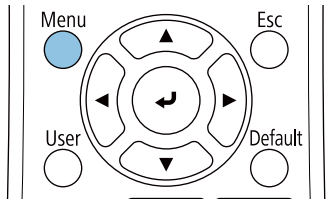

Using the Control Panel

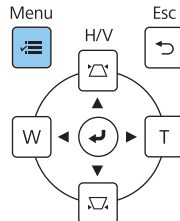

2

Select **Geometry Correction** from the **Installation** menu

| | |
|-----------------------|--------------------------------------|
| Frequently Used Items | Installation |
| Image | Fixed Installation Off |
| Signal I/O | Test Pattern |
| Installation | Setting Plate Installation Guide |
| Display | Vertical Installation No |
| Operation | Projection Front/Upside Down |
| Management | Auto Screen Adjustment |
| Network | Geometry Correction Point Correction |
| Pen/Touch | Digital Zoom |
| Interactive | Connect ELPCB02 Off |
| Memory | Touch Unit |
| ECO | Remote Receiver Off |
| Initial/All Settings | Projector ID Off |
| | Screen Type 16:9 |
| | High Altitude Mode Off |
| | Reset Installation Settings |
| | Display |
| | Pattern Display |

3

Select **Arc Correction**

| | |
|-------------------------|--------|
| [Geometry Correction] | Return |
| H/V-Keystone | |
| Quick Corner | |
| ✓ Arc Correction | |
| Point Correction | |
| Memory | |

4 Select the side you want to correct and make adjustment

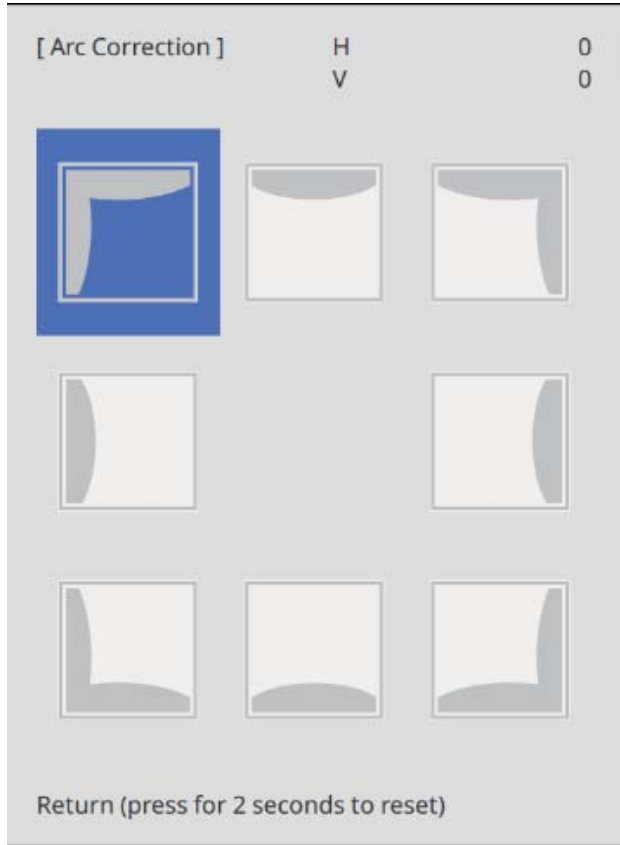

When you reach a range that cannot be adjusted, you see the message **Cannot adjust any further.** displayed.

5 When you have finished making adjustments, press the [Esc] button on the remote control or the control panel to finish adjustment

Quick Corner

1 Press the [Menu] button

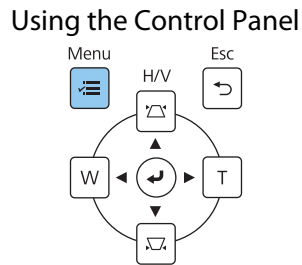
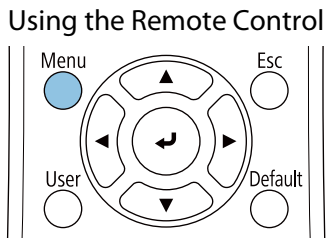

2

Select **Geometry Correction** from the **Installation** menu

| | |
|-----------------------|--------------------------------------|
| Frequently Used Items | Installation |
| Image | Fixed Installation Off |
| Signal I/O | Test Pattern |
| Installation | Setting Plate Installation Guide |
| Display | Vertical Installation No |
| Operation | Projection Front/UpSide Down |
| Management | Auto Screen Adjustment |
| Network | Geometry Correction Point Correction |
| Pen/Touch | Digital Zoom |
| Interactive | Connect ELPCB02 Off |
| Memory | Touch Unit |
| ECO | Remote Receiver Off |
| Initial/All Settings | Projector ID Off |
| | Screen Type 16:9 |
| | High Altitude Mode Off |
| | Reset Installation Settings |
| | Display |
| | Pattern Display |

3

Select **Quick Corner**

| | |
|-------------------------|--------|
| [Geometry Correction] | Return |
| H/V-Keystone | |
| ✓ Quick Corner | |
| Arc Correction | |
| Point Correction | |
| Memory | |

4 Select the side you want to correct and make adjustment

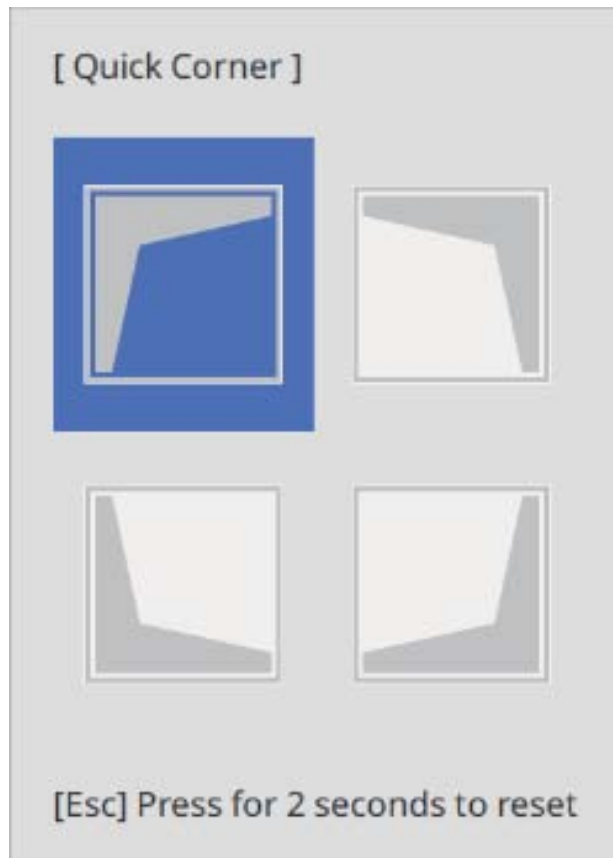

When you reach a range that cannot be adjusted, you see the message **Cannot adjust any further.** displayed.

 While adjusting the sides, press buttons [1], [3], [7], and [9] on the remote control to select the side you want to adjust.

5 When you have finished making adjustments, press the [Esc] button on the remote control or the control panel to finish adjustment

Point Correction

1 Press the [Menu] button

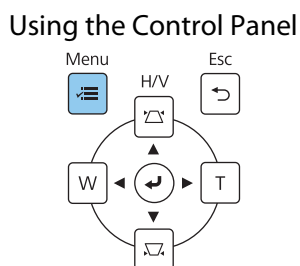
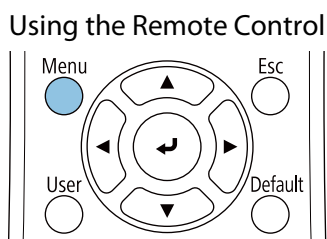

2

Select **Geometry Correction** from the **Installation** menu

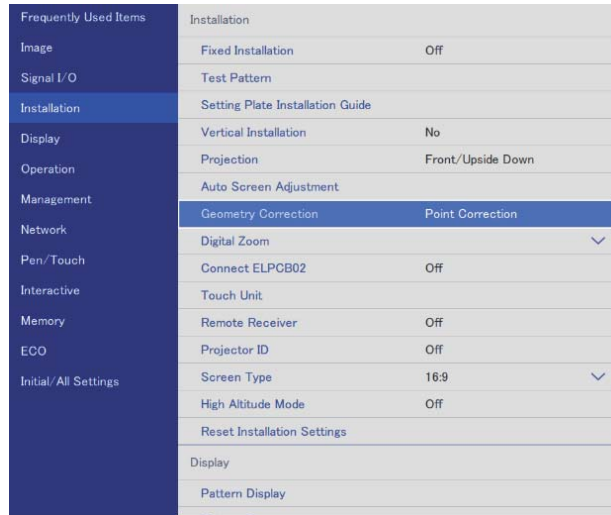

3

Select **Point Correction**

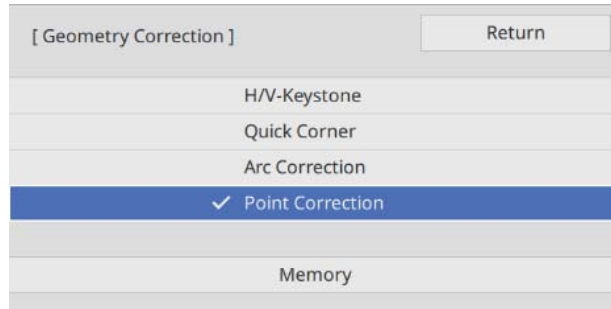

4

Select **Point Correction** and then select the number of grid

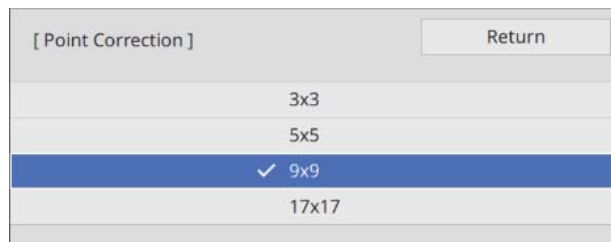

5

Select the points you want to correct and make adjustment

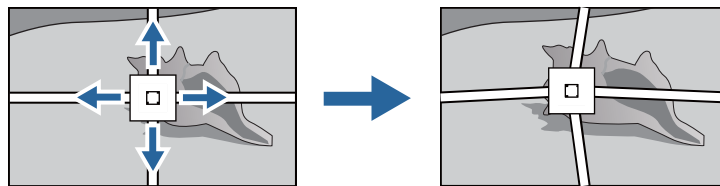
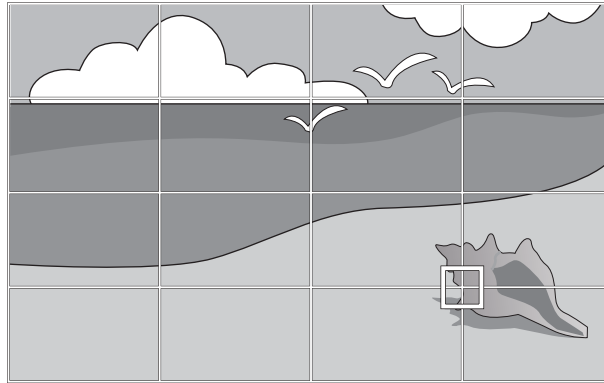

If it is hard to see the grid, use **Pattern Color** to change the color of the grid.

6

When you have finished making adjustments, press the [Esc] button on the remote control or the control panel to finish adjustment

Attaching the Covers

1

Attach the left wall plate cover

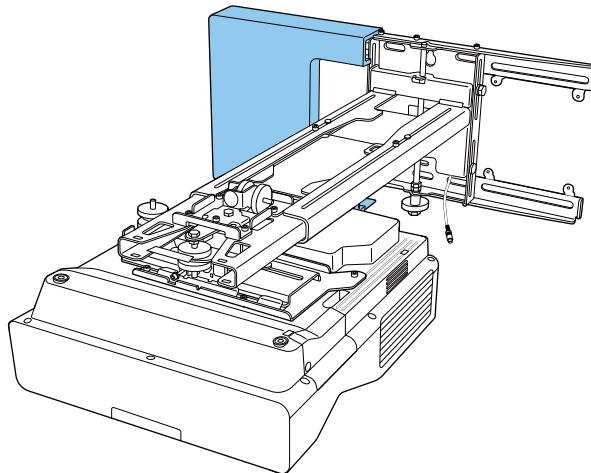

2

Attach the right wall plate cover

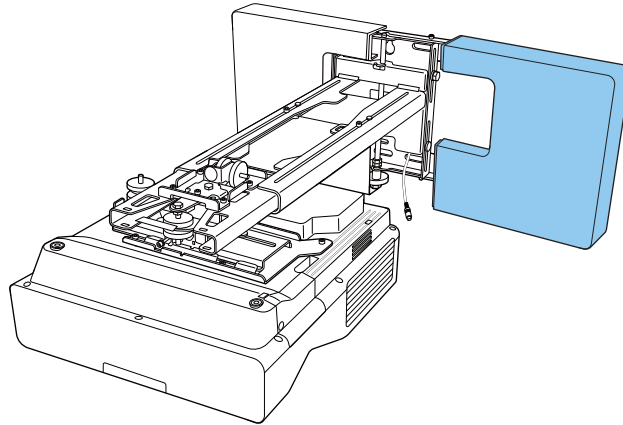

3

Fit the end cap to the setting plate

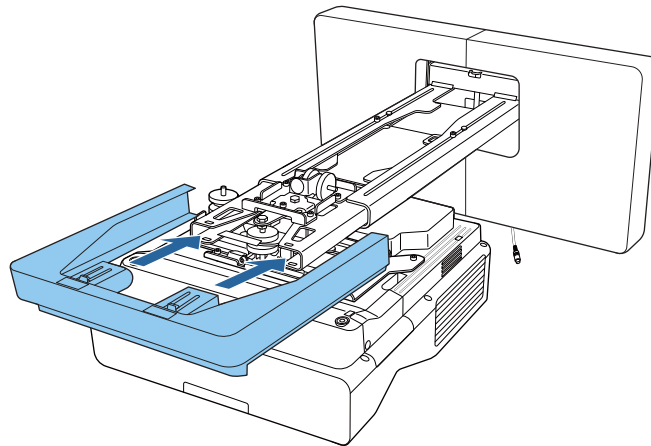

If you are concerned about the groove in the arm, stick the supplied masking sticker.

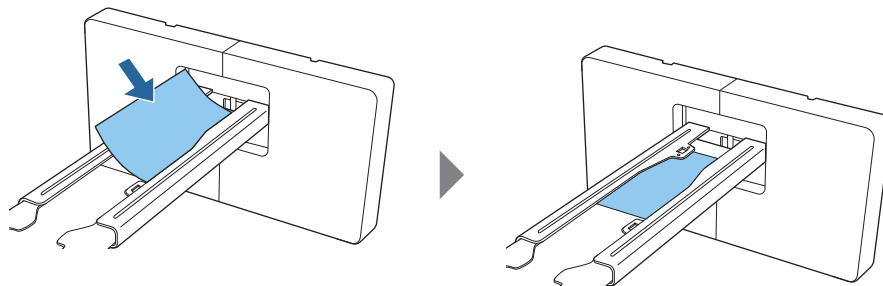

Attaching a Security Cable

Perform one of the following security measures if necessary.

- Install a commercially available theft-prevention wire lock

Pass the wire lock through the security cable installation points on the projector and the setting plate.

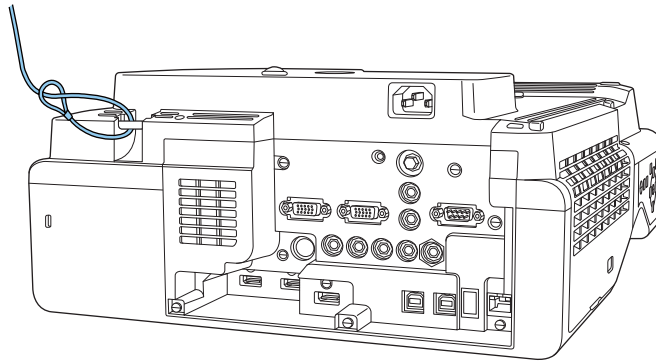



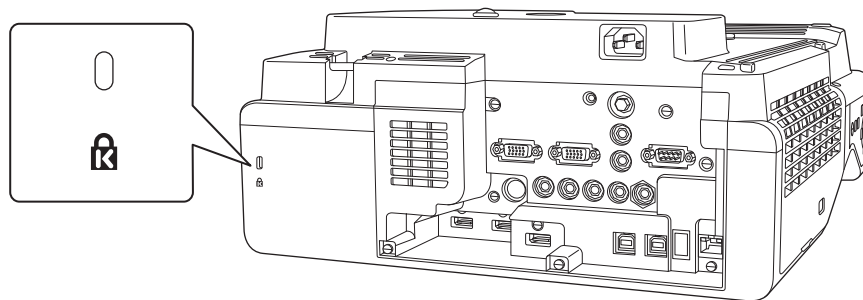

- Install a security wire from Kensington

The security slot on this product is compatible with the Microsaver Security System manufactured by Kensington. See the following for more details on the Microsaver Security System.

<http://www.kensington.com/>



Notes on the Pen Stand

|  Warning | |
|--|---|
| <p>Do not go near the pen stand if you are using medical equipment such as a pace maker. Furthermore, when using the pen stand, make sure there is no one using medical equipment such as a pace maker, in the surrounding area.</p> <p>A powerful magnet within the unit generates electromagnetic interference which may cause medical equipment to malfunction.</p> |  |
|  Caution | |
| <p>Do not go near the pen stand with magnetic storage media such as magnetic cards, or precision electronic devices such as computers, digital watches, or mobile phones.</p> <p>A powerful magnet within the unit could corrupt data or cause a malfunction.</p> |  |
| <p>The magnet on the back of the pen stand exerts a powerful magnetic attraction on the installation surface. When installing, be careful not to trap your fingers or any other part of your body between the magnets and the installation surface.</p> |  |

Pen Stand Specifications

| Item | Specification |
|----------------|---------------|
| Pen stand mass | Approx. 93 g |

External Dimensions

[Unit: mm]

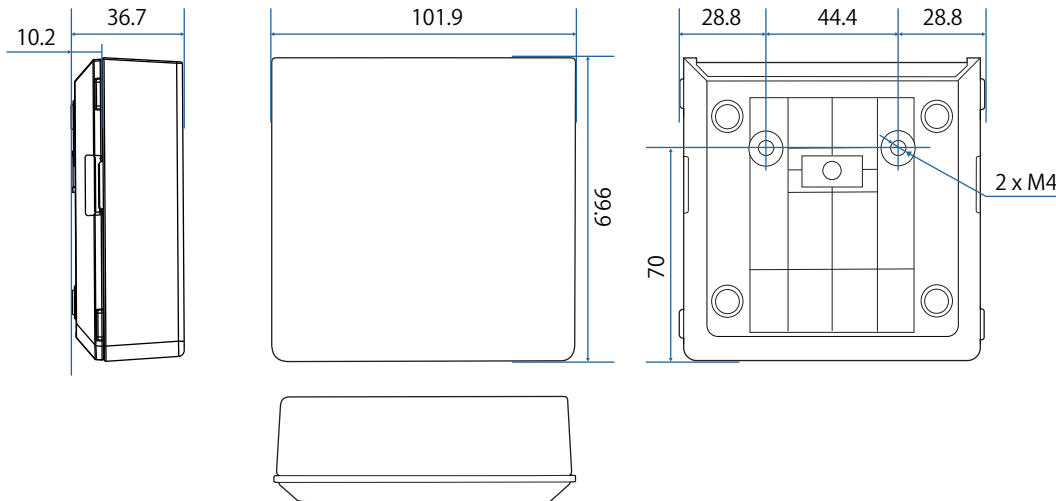



Installing the Pen Stand

Secure the pen stand with magnets or commercially available M4 screws.

When Securing with Magnets

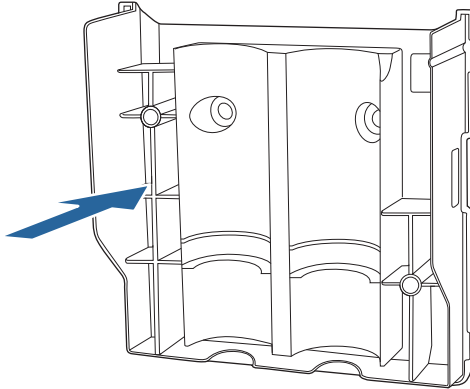
1 Check the installation position and secure with magnets



 **Caution**

Powerful magnets are used which can cause injury if you trap your fingers. Be careful not to trap your fingers or any other part of your body between the magnets and the installation surface.

2 Attach the cover

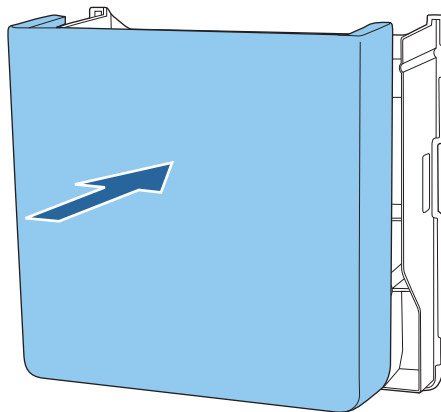

3

Store the interactive pens

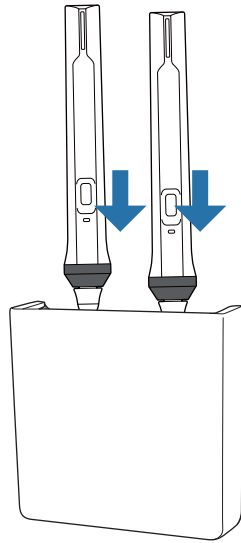

When Securing with Screws

1

Check the installation position and secure with commercially available M4 screws (20 mm x2)

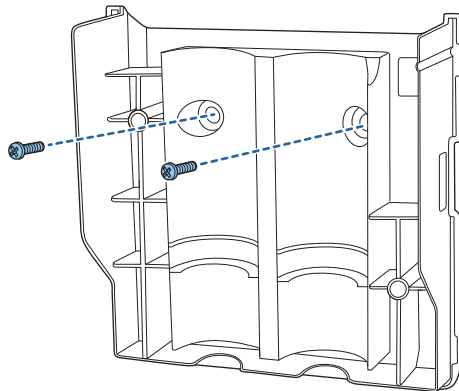

Warning

- When screwing, make sure they are not tilted at an angle to the installation surface.
- Make sure that the pen stand is secured properly.

2

Attach the cover

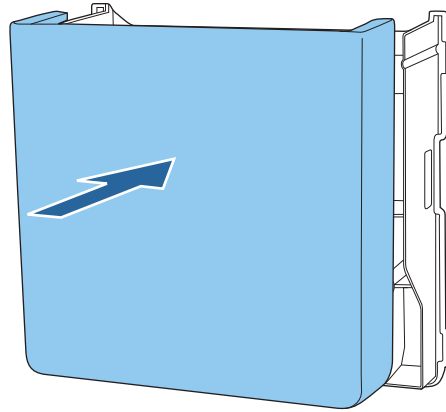

3

Store the interactive pens

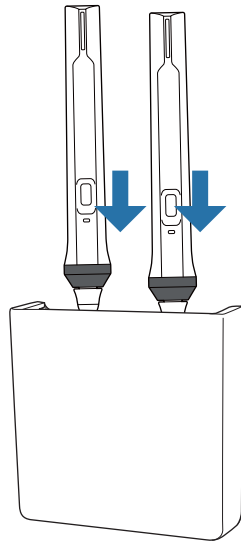

Calibrating the Interactive Pen

Adjust the projector’s image before calibrating the pen.

There are two methods available for calibrating the pen; **Auto Calibration** and **Manual Calibration**.

When calibrating the pen for the first time, perform **Manual Calibration** for optimum calibration.

When calibrating the pen for the second time and after, perform **Auto Calibration**. (p.81)

Manual Calibration

1 Turn on the projector, and then press the [Menu] button

Using the Remote Control

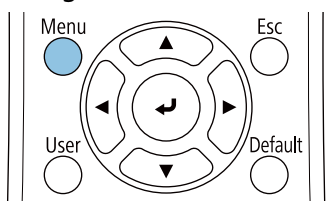

Using the Control Panel

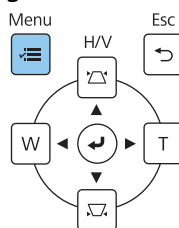

2 Select **Manual Calibration** from the **Pen/Touch** menu.

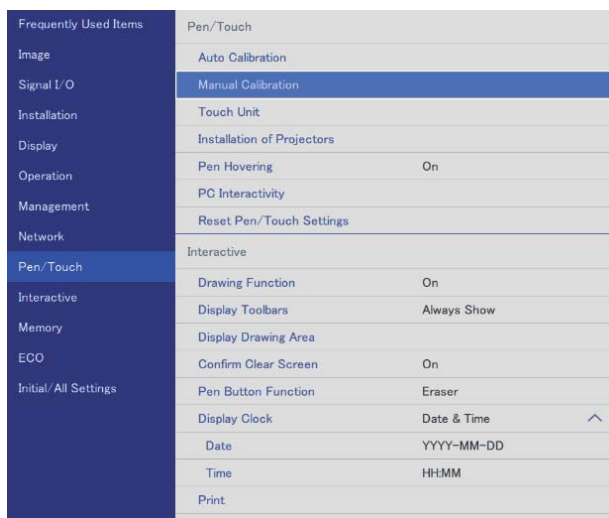

3

Check the screen content, and then select **Yes**

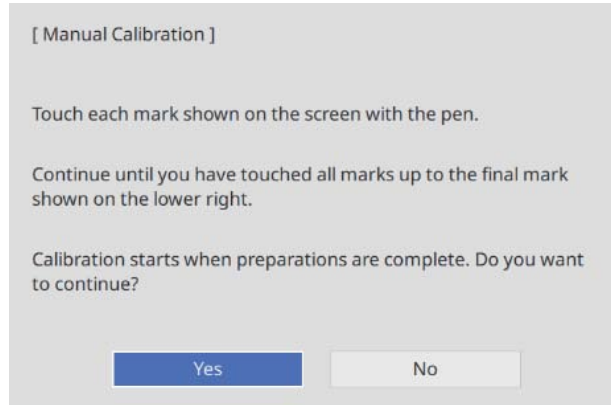

You see a green dot at the top left of the projection screen.

4

Touch the center of the dot with the pen tip of the interactive pen

The dot disappears and moves to the next position.

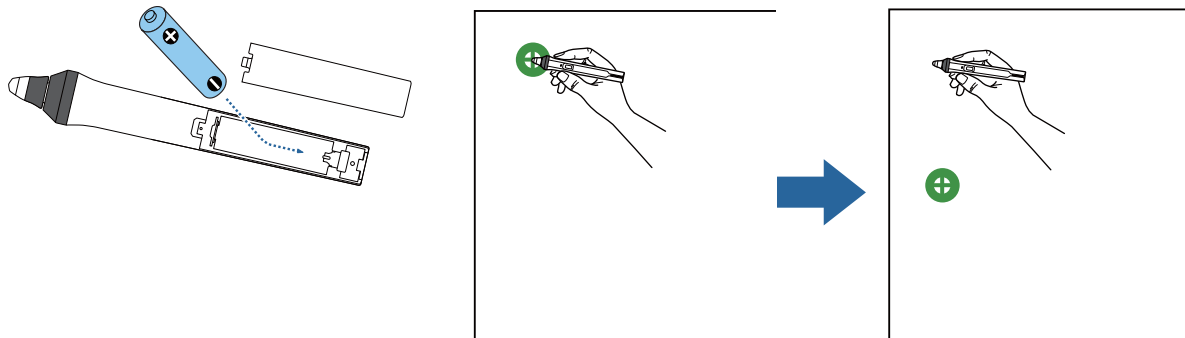

Make sure you touch the center of the dot. Otherwise, it may not be positioned correctly.

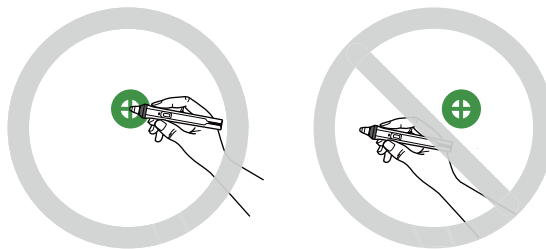

5 Repeat step 4 until all of the dots disappear

The dot appears at the top left first and then moves towards the bottom right.

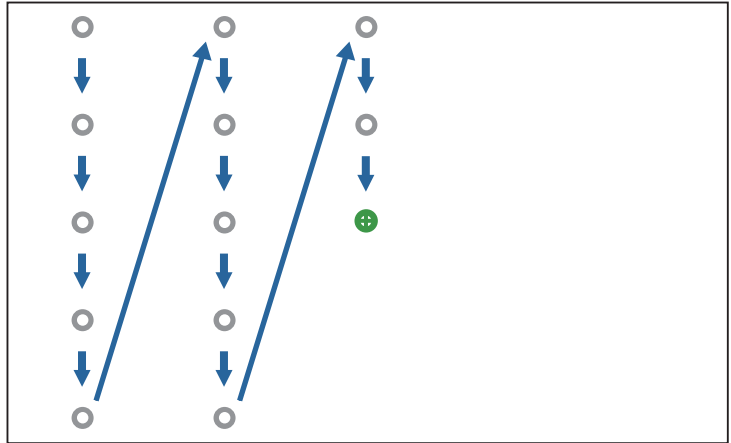

When all of the dots disappear, Manual Calibration is complete.



- Check that there are no obstacles between the interactive pen and the Interactive pen receiver (shown below).

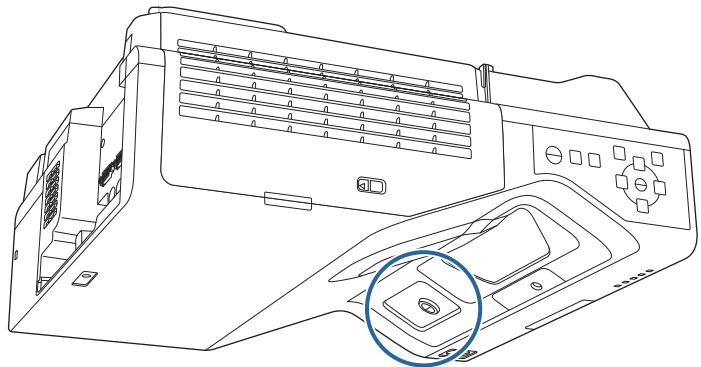

- If you touch the wrong position, press the [Esc] button on the remote control to return to the previous dot.
- To cancel calibration, hold down the [Esc] button for two seconds.

Auto Calibration

1 Turn on the projector, and then press the [Menu] button

Using the Remote Control

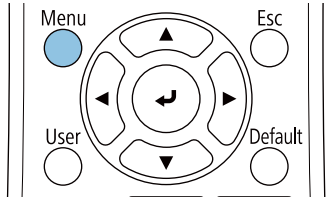

Using the Control Panel

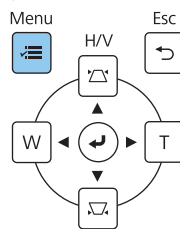

2

Select **Auto Calibration** from the **Pen/Touch** menu

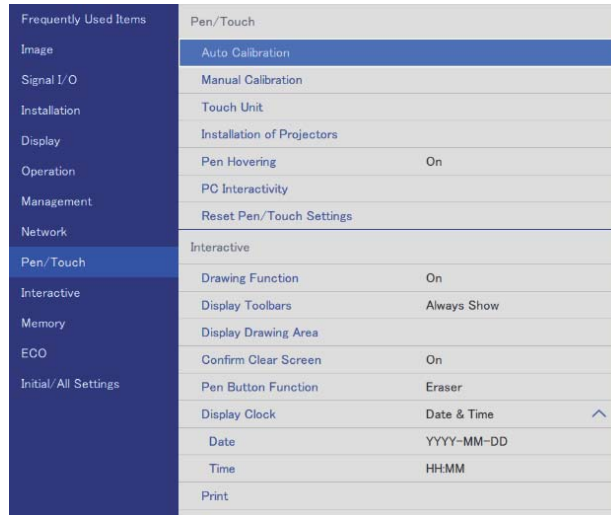

3

Check that the pattern image fits into the projected image, and then select **Yes**

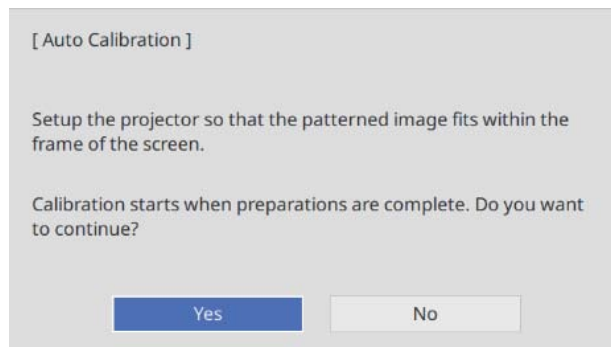









Pen calibration starts automatically.



If Auto Calibration fails, follow the on-screen instructions to check your surroundings. Or, perform **Manual Calibration**.

Notes on Handling the Touch Unit

|  Warning | |
|--|---|
| <p>Do not disassemble or remodel the Touch Unit.</p> <p>The Touch Unit contains a high power laser product that could cause a fire, electric shock, or an accident.</p> |  |
| <p>Only connect the Touch Unit to the EB-735Fi/EB-725Wi. Do not connect it to any other projectors or devices.</p> <p>The device could malfunction, or laser light that is higher than normal intensity could be emitted.</p> |  |
| <p>Do not go near the Touch Unit if you are using medical equipment such as a pace maker. Furthermore, when using the Touch Unit, make sure there is no one using medical equipment such as a pace maker, in the surrounding area.</p> <p>A powerful magnet within the unit generates electromagnetic interference which may cause medical equipment to malfunction.</p> |  |
|  Caution | |
| <p>Do not go near the Touch Unit with magnetic storage media such as magnetic cards, or precision electronic devices such as computers, digital watches, or mobile phones.</p> <p>A powerful magnet within the unit could corrupt data or cause a malfunction.</p> |  |
| <p>The magnet on the back of the Touch Unit exerts a powerful magnetic attraction on the installation surface. When installing, be careful not to trap your fingers or any other part of your body between the magnets and the installation surface.</p> |  |
| <p>Do not disassemble the Touch Unit when disposing of it.</p> <p>Dispose according to your local or national laws and regulations.</p> |  |

Complies with FDA performance standards for laser products except for deviations pursuant to Laser Notice No. 50, dated June 24, 2007

Supplier's DECLARATION of CONFORMITY

According to 47CFR, Part 2 and 15

Other Class B digital devices & peripherals

We: Epson America, Inc.
Located at: 3840 Kilroy Airport Way
Long Beach, CA 90806
Tel: 562-981-3840

Declare under sole responsibility that the product identified herein, complies with 47CFR Part 2 and 15 of the FCC rules as a Class B digital device. Each product marketed, is identical to the representative unit tested and found to be compliant with the standards. Records maintained continue to reflect the equipment being produced can be expected to be within the variation accepted, due to quantity production and testing on a statistical basis as required by 47CFR 2.906. Operation is subject to the following two conditions : (1) this device may not cause harmful interference, and (2) this device must accept any interference received, including interference that may cause undesired operation.

Trade Name: EPSON
Type of Product: FINGER TOUCH UNIT
Model: EAI destination: ELPFT01
Other destination: ---

FCC Compliance Statement

For United States Users

This device complies with part 15 of the FCC Rules. Operation is subject to the following two conditions: (1) This device may not cause harmful interference, and (2) this device must accept any interference received, including interference that may cause undesired operation.

This equipment has been tested and found to comply with the limits for a Class B digital device, pursuant to Part 15 of the FCC Rules. These limits are designed to provide reasonable protection against harmful interference in a residential installation. This equipment generates, uses, and can radiate radio frequency energy and, if not installed and used in accordance with the instructions, may cause harmful interference to radio communications. However, there is no guarantee that interference will not occur in a particular installation. If this equipment does cause interference to radio and television reception, which can be determined by turning the equipment off and on, the user is encouraged to try to correct the interference by one or more of the following measures.

- Reorient or relocate the receiving antenna.
- Increase the separation between the equipment and receiver.
- Connect the equipment into an outlet on a circuit different from that to which the receiver is connected.
- Consult the dealer or an experienced radio/TV technician for help.

WARNING

The connection of a non-shielded equipment interface cable to this equipment will invalidate the FCC Certification or Declaration of this device and may cause interference levels which exceed the limits established by the FCC for this equipment. It is the responsibility of the user to obtain and use a shielded equipment interface cable with this device. If this equipment has more than one interface connector, do not leave cables connected to unused interfaces. Changes or modifications not expressly approved by the manufacturer could void the user's authority to operate the equipment.

For Canadian Users

CAN ICES-3 (B) / NMB-3 (B)

Touch Unit Installation Location

The procedure differs depending on where the Touch Unit is installed.

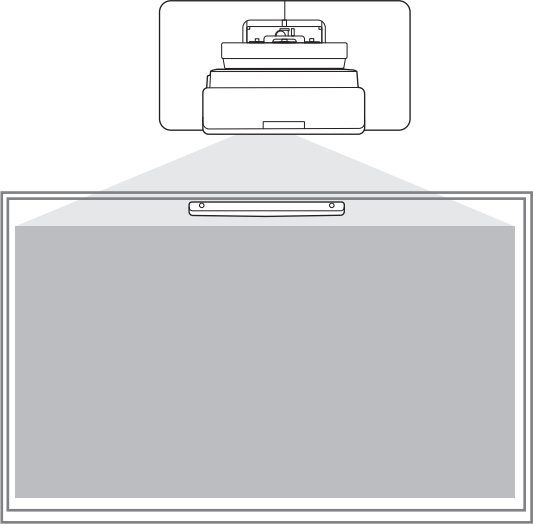
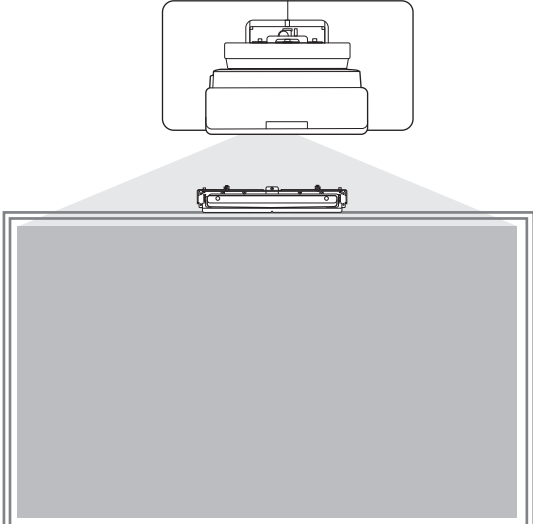
| When installed on the projection surface: Secure with magnets or screws | When installed on a different surface: Secure with the Touch Unit Bracket |
|---|--|
|  |  |

 Caution

When using the Touch Unit, images should be projected onto the front of the screen. You cannot use finger touch operations when images are projected onto the rear of the screen.



Before installing the Touch Unit, make sure that the installation surface is not warped or distorted, and that any unevenness on the screen surface is less than 5 mm.

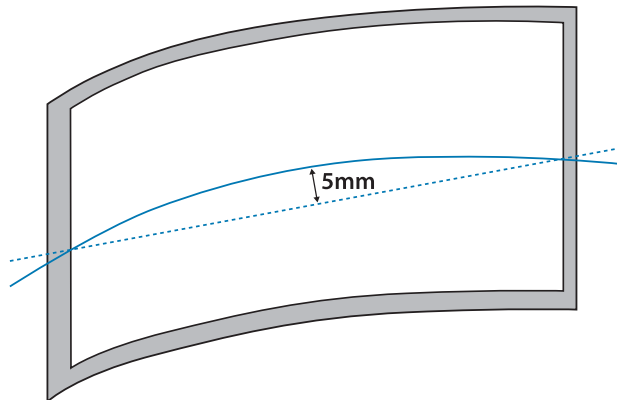

Notes on the Touch Unit Bracket

 Caution

If there is a frame around the screen, make sure that the thickness of the top of the frame is less than 3 mm.



If the thickness of the top of the screen exceeds 3 mm, the Touch Unit will not operate correctly.

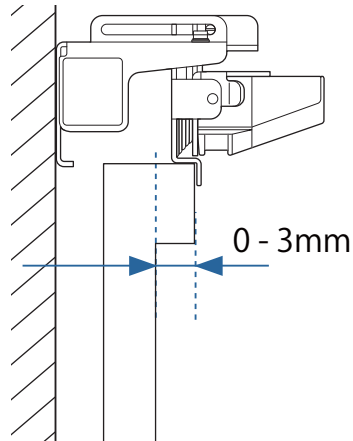

Make sure that the distance from the wall to the surface of the screen is less than 50 mm.



You cannot install the Touch Unit Bracket if the distance is more than 50 mm.

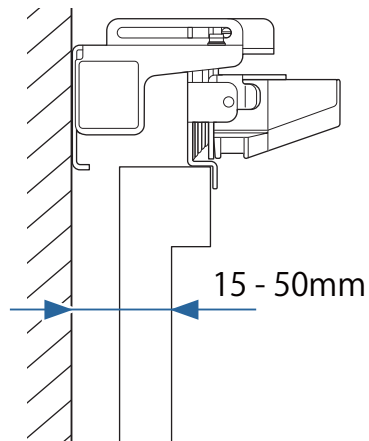

Notes on the Laser

Attached Labels

The Touch Unit is a Class 1 laser product that conforms to the IEC/EN60825-1:2014 standard.

The Touch Unit is a Class 1 laser product that conforms to the IEC/EN60825-1:2007 standard. (For North/South America.)

There are warning labels affixed to the Touch Unit to indicate that it is a Class 1 laser product.

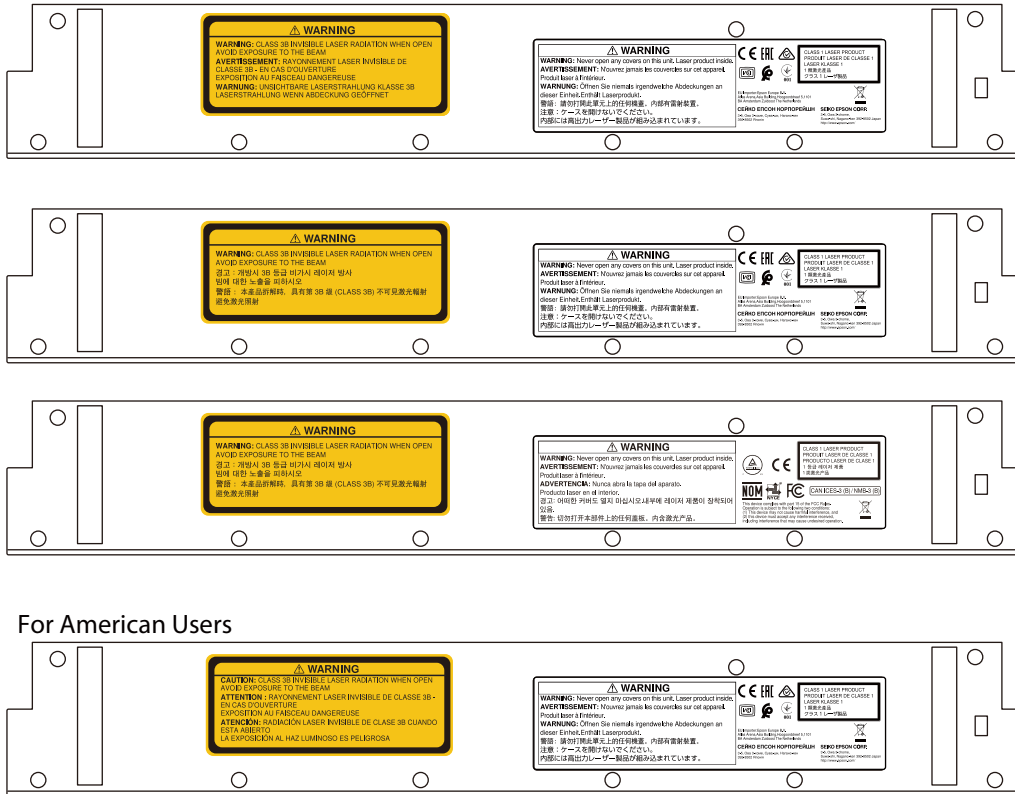

The labels contain the following information.

- Class 1 laser product
- Warning: Do not open the case. The device contains a high power laser product.
- Warning:
 - Caution: If this section is opened, class 3B invisible laser radiation will be emitted.
 - Avoid exposure to the radiation beams.

Laser Diffusion Port

The laser beam is diffused from the laser diffusion ports at the back of the Touch Unit.

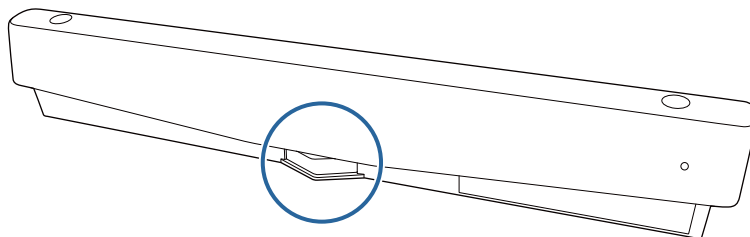

- Light source output: Max. 285 W

- Wavelength: 932 to 952 nm

Touch Unit Specifications

| Item | Specification |
|-------------------------------------|----------------|
| Touch unit mass | Approx. 0.6 kg |
| Operating temperature | 0 to 40°C |
| Power (supplied from the projector) | 5 VDC 0.65 A |

External Dimensions

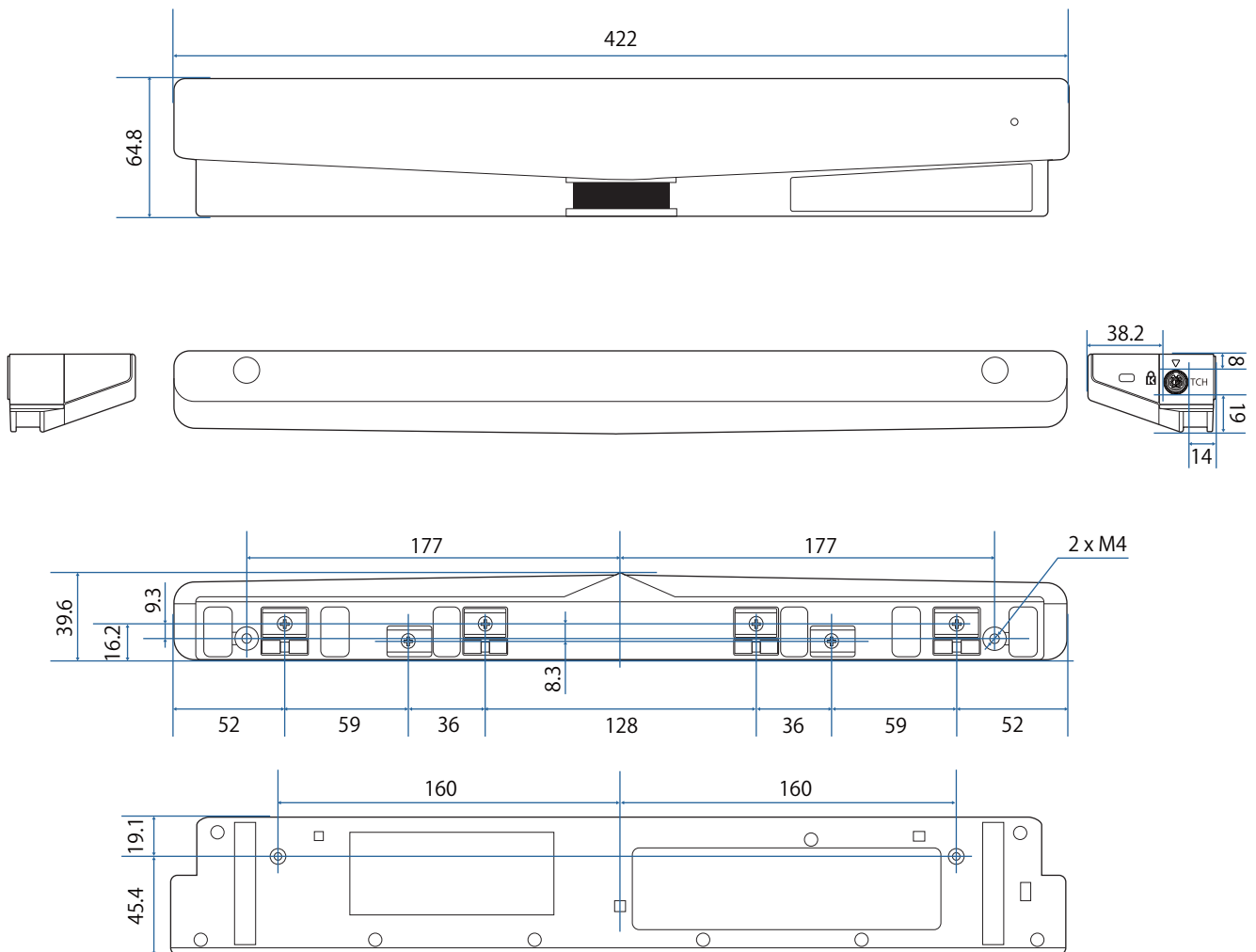

Touch Unit Bracket Specifications

| Item | Specification |
|-------------------------|----------------|
| Touch unit bracket mass | Approx. 1.8 kg |
| Maximum load capacity | Approx. 8.8 kg |

External Dimensions

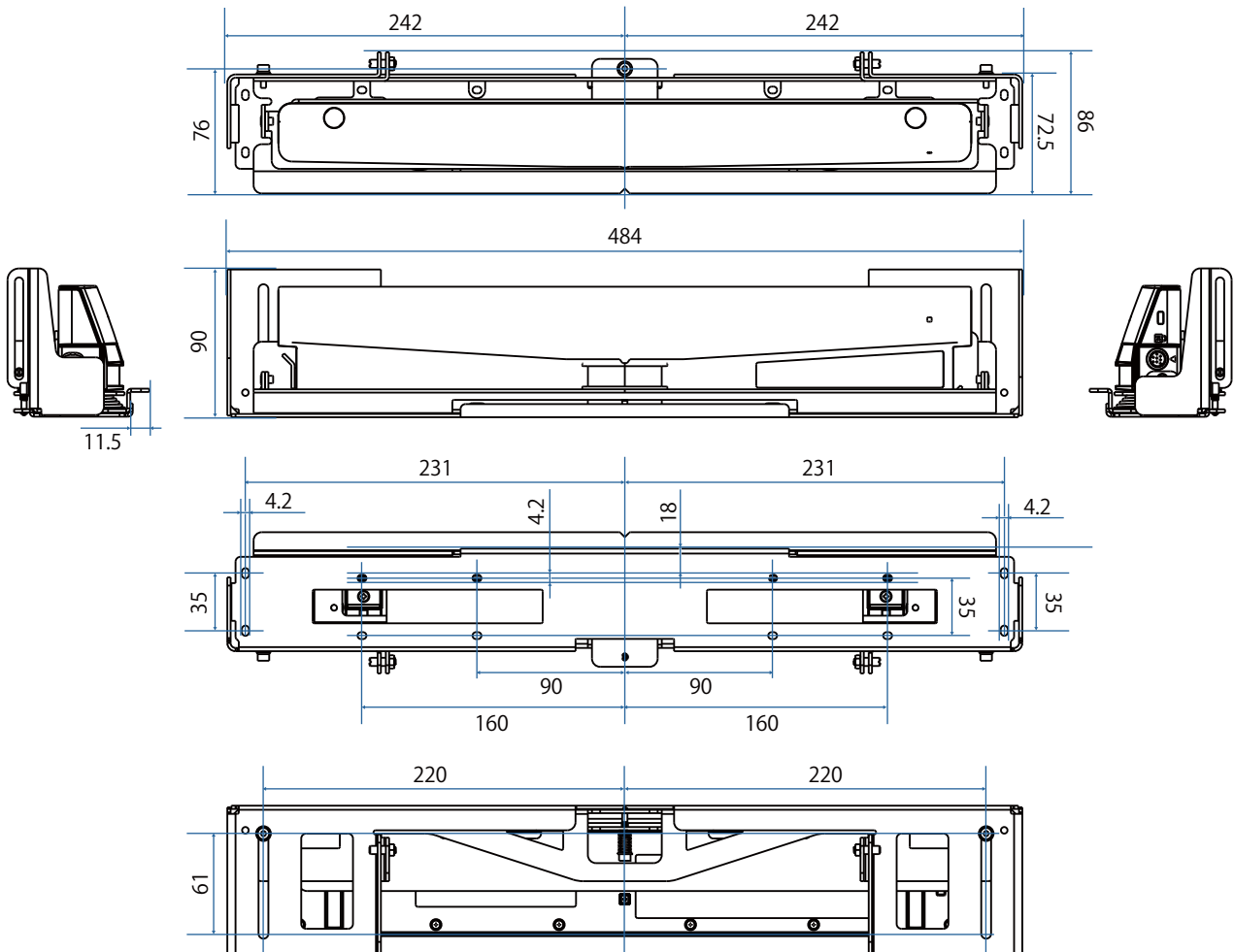

Adjustment Range

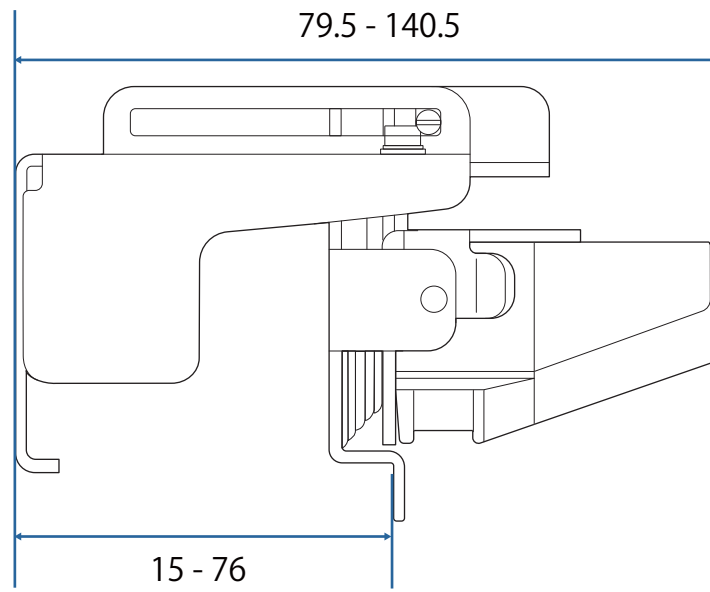

When Using an Older Model of Touch Unit

Touch Units that have been used with previous projector models can be re-connected and used again.

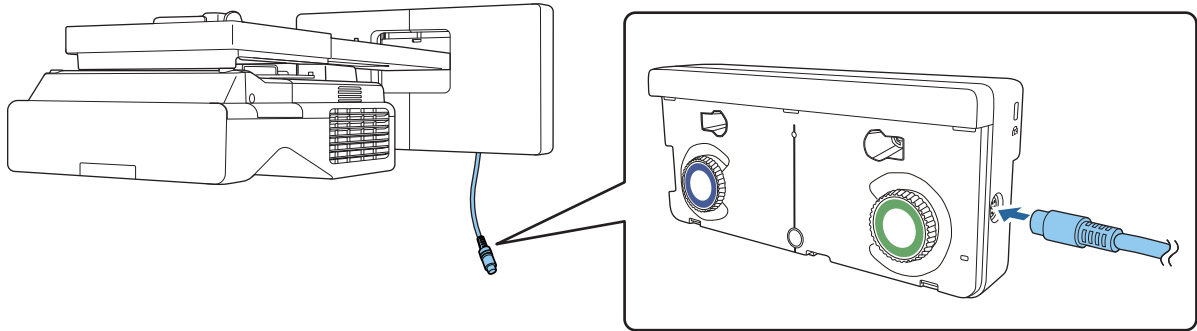

After connecting, follow the steps below to setup the Touch Unit.

- 1** Turn on the Touch Unit (☞ [p.103](#))
- 2** Adjust the Angle of the Laser (☞ [p.104](#))
- 3** Perform Touch Calibration (☞ [p.112](#))



When infrared deflectors are attached to the projection surface, use it without removing them.

Installing the Touch Unit

Installing the Infrared Deflectors

Stick the infrared deflectors to any obstacles, such as a frame or tray, at the bottom of the projection surface. If there are any obstacles, the laser is reflected as shown below, and the location of your finger will not be detected correctly.

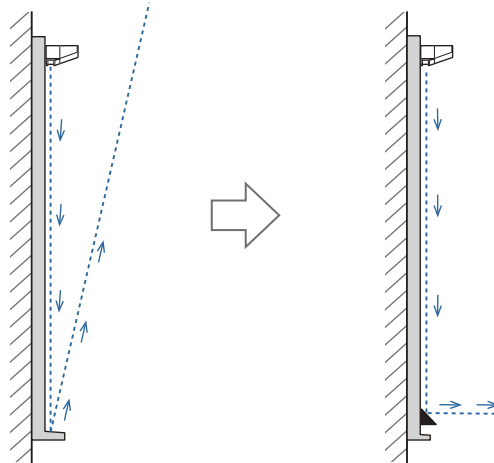

If you have already attached infrared deflectors to the projection surface, use it without removing them.

1

Stick the supplied infrared deflectors along the locations of the obstacles

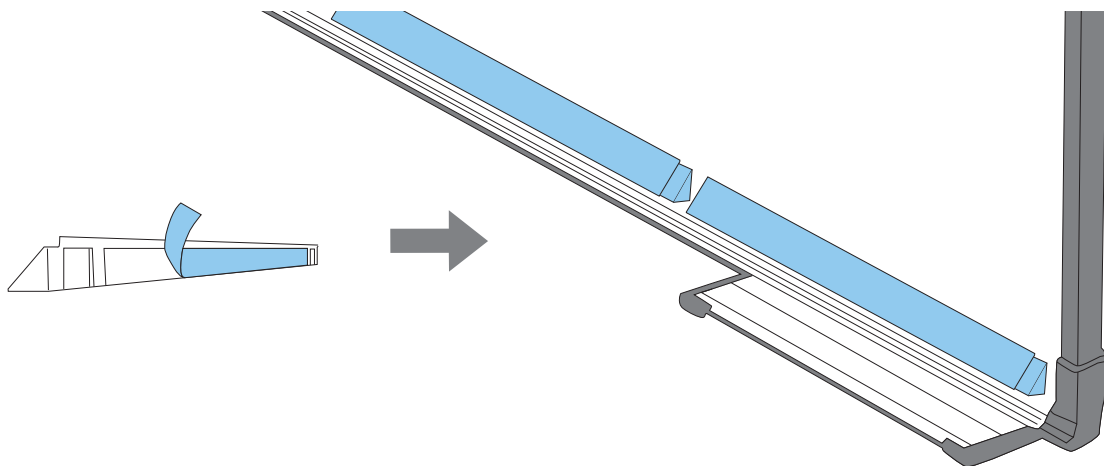

Installing the Touch Unit

■ When installing on the projection surface without using the Touch Unit Bracket

1 Turn on the projector, and then press the [Menu] button

Using the Remote Control

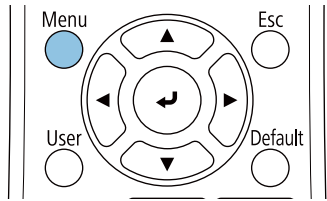

Using the Control Panel

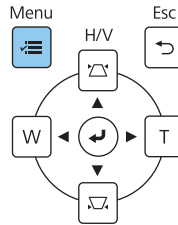

2 Select **Touch Unit** from the **Installation** menu

| | | |
|-----------------------|----------------------------------|-------------------|
| Frequently Used Items | Installation | |
| Image | Fixed Installation | Off |
| Signal I/O | Test Pattern | |
| Installation | Setting Plate Installation Guide | |
| Display | Vertical Installation | No |
| Operation | Projection | Front/Upside Down |
| Management | Auto Screen Adjustment | |
| Network | Geometry Correction | Point Correction |
| Pen/Touch | Digital Zoom | ▼ |
| Interactive | Connect ELPCB02 | Off |
| Memory | Touch Unit | |
| ECO | Remote Receiver | Off |
| Initial/All Settings | Projector ID | Off |
| | Screen Type | 16:9 ▼ |
| | High Altitude Mode | Off |
| | Reset Installation Settings | |
| | Display | |
| | Pattern Display | |

3

Select **Installation Pattern**

| | | |
|----------------------|------|--------|
| [Touch Unit] | | Return |
| Installation Pattern | | |
| Power | On | |
| Touch Unit Setup | | |
| Touch Calibration | | |
| Calibration Range | Wide | |

You see the installation pattern on the projected image.



4

When installing on a magnetic surface, check the installation position and attach the touch unit with magnets

When installing on a non-magnetic surface, go to the next step.

Caution

Powerful magnets are used which can cause injury if you trap your fingers. Be careful not to trap your fingers or any other part of your body between the magnets and the installation surface.

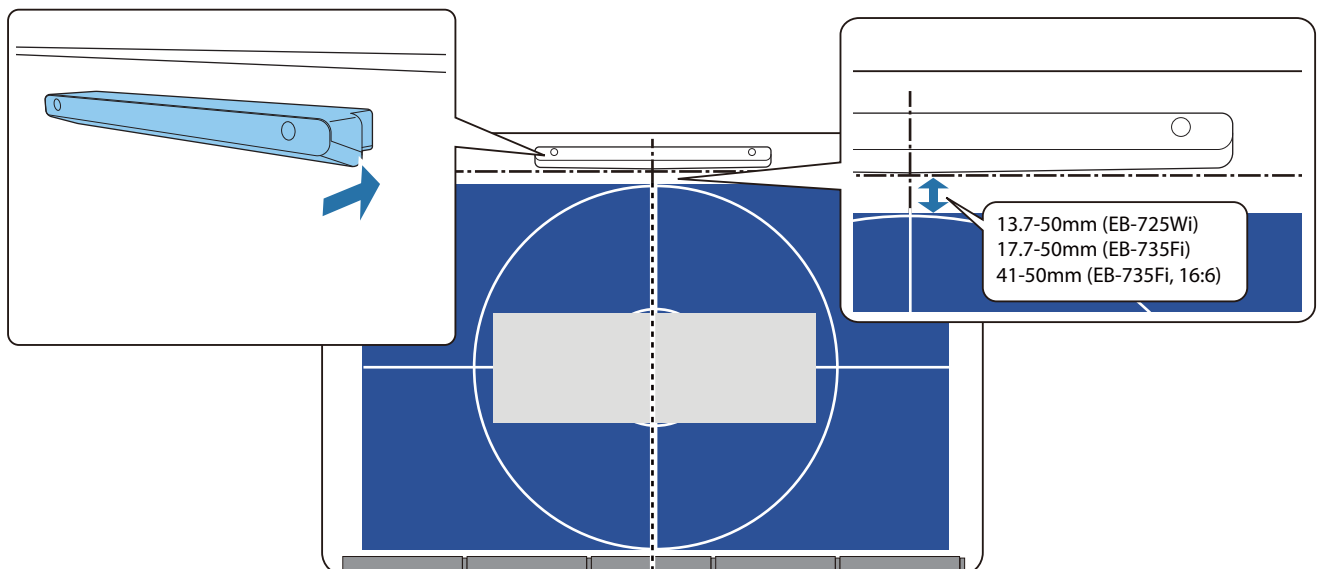

After you attach the Touch Unit, go to "Turning on the Touch Unit" [p.103](#).

5 When installing on a non-magnetic surface, attach the template sheet to the Touch Unit installation position

As shown below, attach the bottom of the template sheet onto the installation pattern.

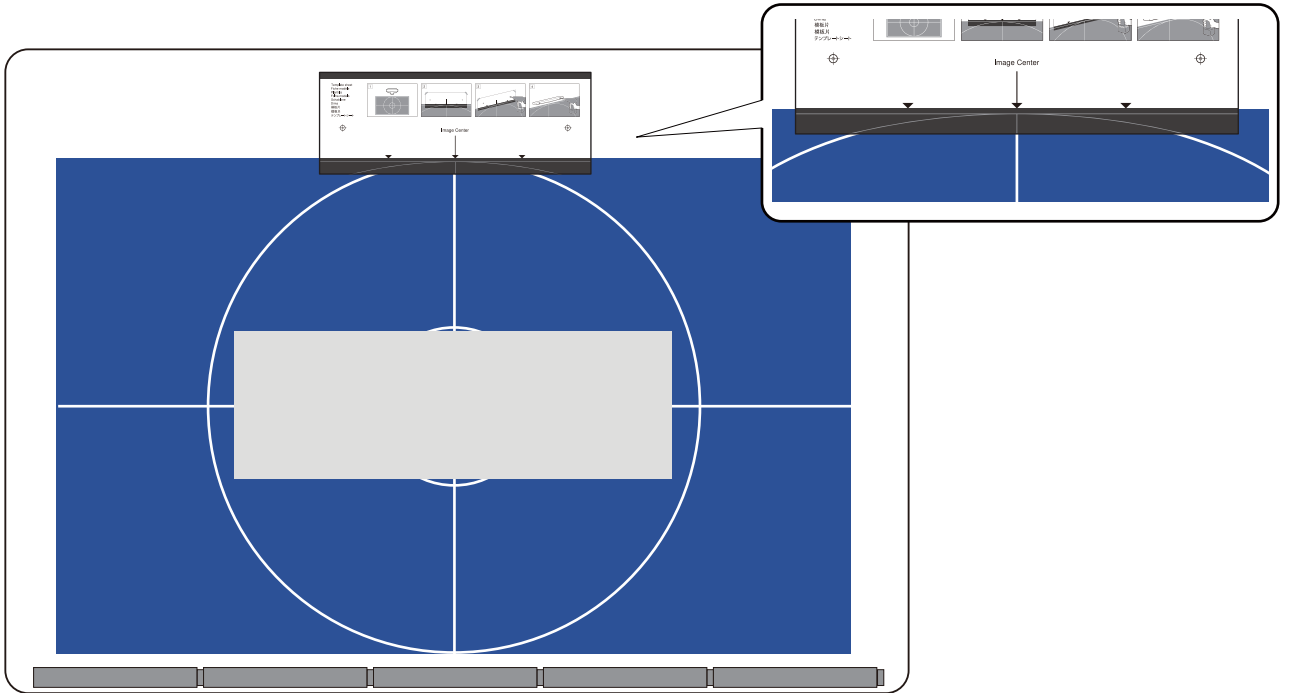

6 Drill holes in the installation surface, and then remove the template sheet

7 Attach the spacers supplied (x2) to the screw holes on the back of the Touch Unit

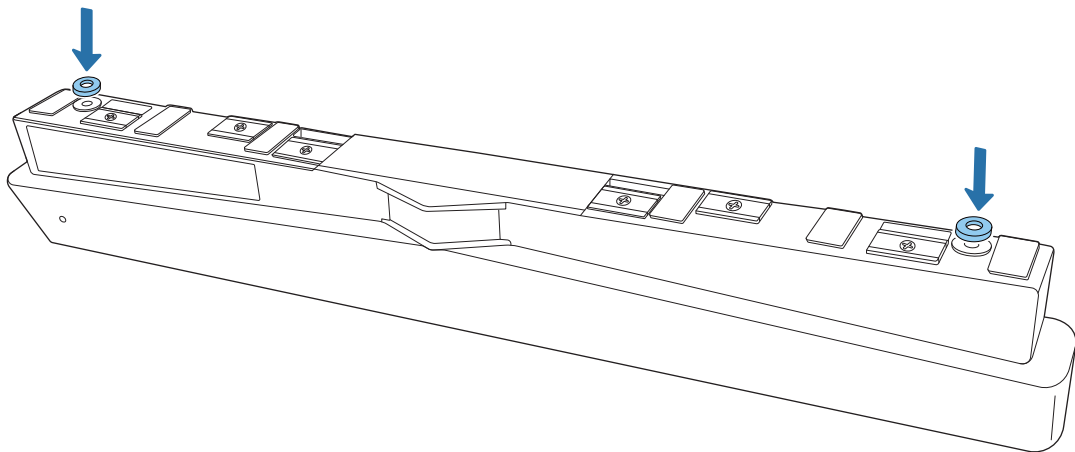

8 Remove the rubber caps (x2) from the front of the Touch Unit

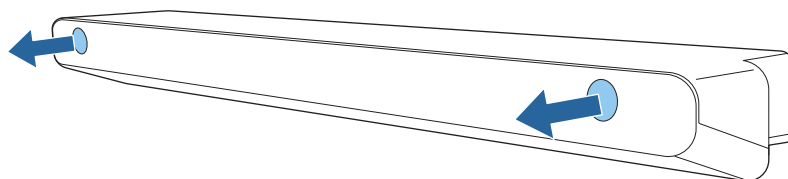

9

Secure the Touch Unit with commercially available M4 screws (x2)

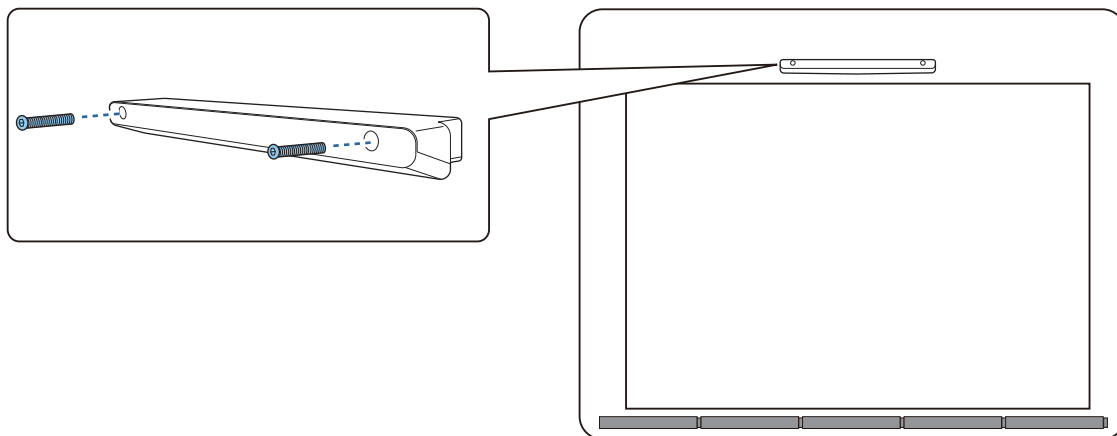

The following shows the depth of the screw holes in the Touch Unit.

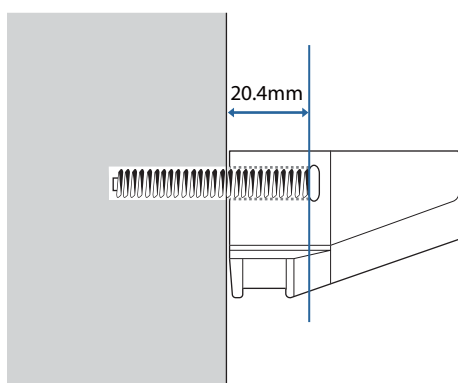

10

Attach the rubber caps that you removed in step 8 to the screw holes on the front of the Touch Unit

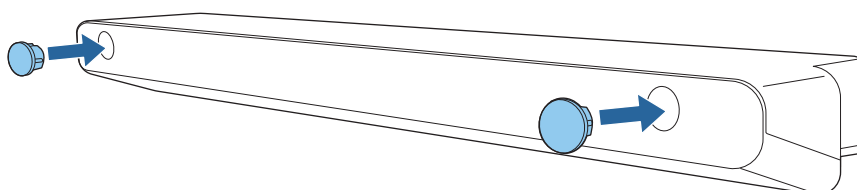

■ When using the Touch Unit Bracket to install outside of the projection surface

1

Turn on the projector, and then press the [Menu] button

Using the Remote Control

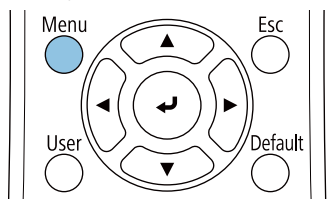

Using the Control Panel

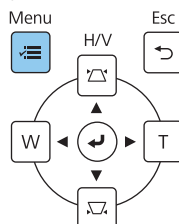

2

Select **Touch Unit** from the **Installation** menu

| | |
|-----------------------|--------------------------------------|
| Frequently Used Items | Installation |
| Image | Fixed Installation Off |
| Signal I/O | Test Pattern |
| Installation | Setting Plate Installation Guide |
| Display | Vertical Installation No |
| Operation | Projection Front/Upside Down |
| Management | Auto Screen Adjustment |
| Network | Geometry Correction Point Correction |
| Pen/Touch | Digital Zoom |
| Interactive | Connect ELPCB02 Off |
| Memory | Touch Unit |
| ECO | Remote Receiver Off |
| Initial/All Settings | Projector ID Off |
| | Screen Type 16:9 |
| | High Altitude Mode Off |
| | Reset Installation Settings |
| | Display |
| | Pattern Display |

3

Select **Installation Pattern**

| | |
|----------------------|--------|
| [Touch Unit] | Return |
| Installation Pattern | |
| Power | On |
| Touch Unit Setup | |
| Touch Calibration | |
| Calibration Range | Wide |

You see the installation pattern on the projected image.



4

Attach the template sheet for the Touch Unit Bracket

Align the top edge of the projection surface with the bottom edge of the template sheet.

If there is a gap between the installation surface for the bracket and the projection surface, we recommend drawing marks in advance at the attachment position.

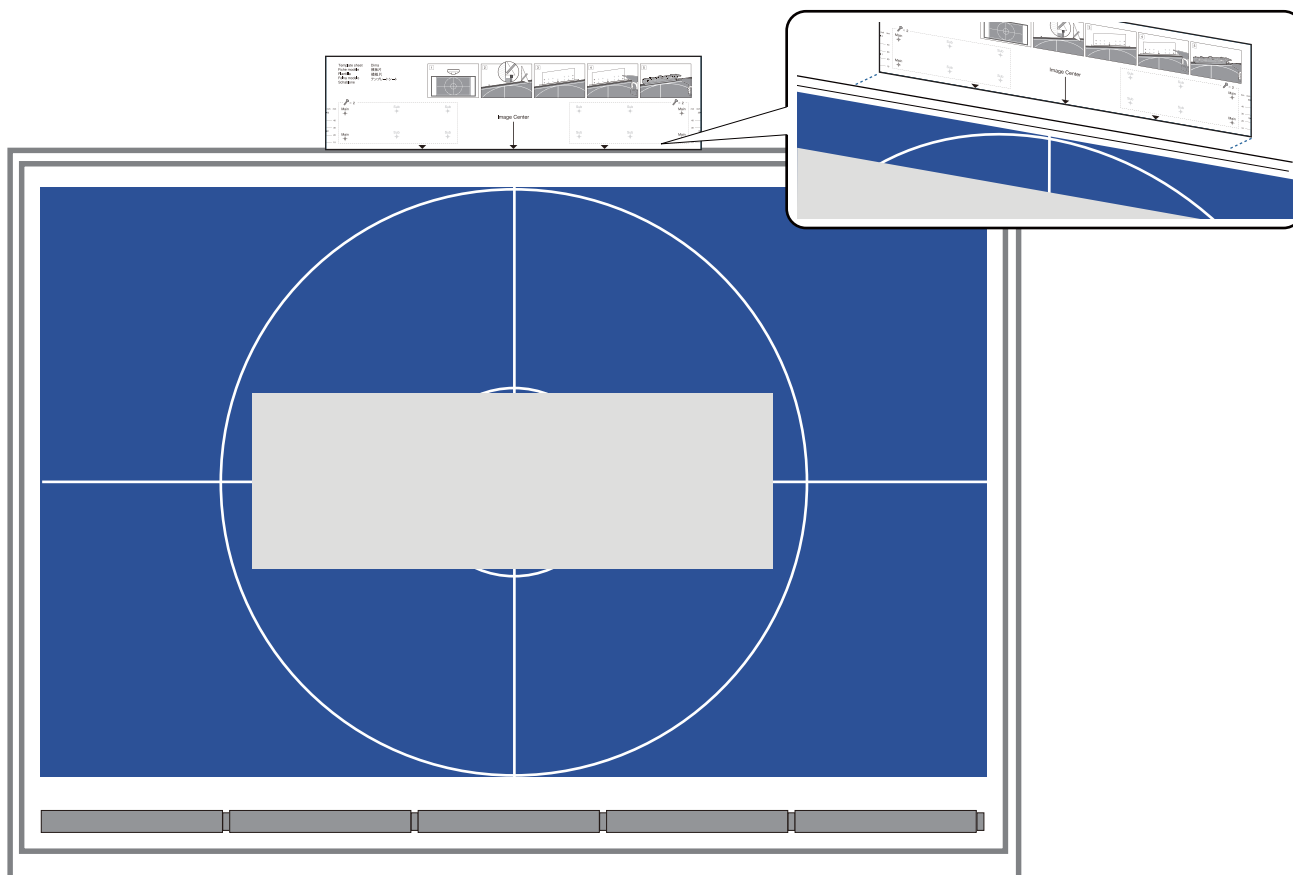

5

Drill holes in the installation surface, and then remove the template sheet

Make holes at the four points labeled as **Main** on the template sheet.

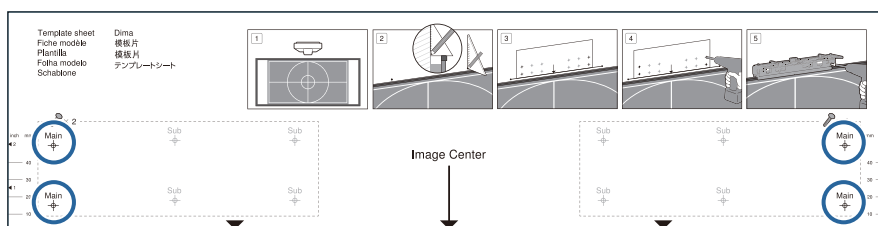

Depending on the condition of the installation surface, you may need to secure the bracket at the points labeled as Sub.

Make holes at four points (two on the left and two on the right) for optimum balance.

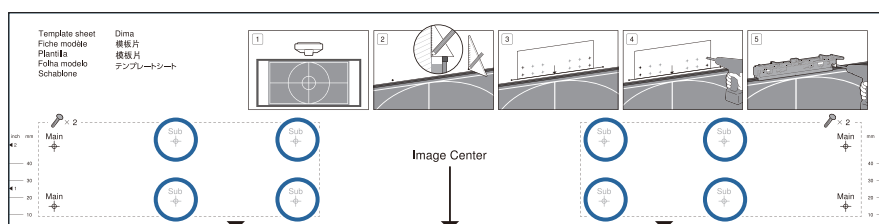

6

Loosen the screws (x2) at the top of the Touch Unit Bracket

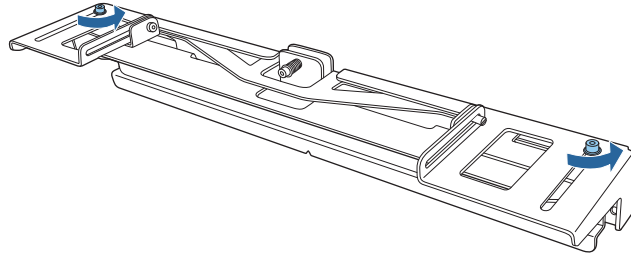

7

Slide the parts at the front of the bracket forward until they are fully extended

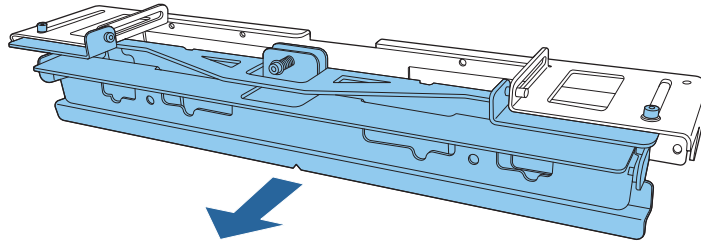

To prevent the sliding section from slipping during installation, lightly tighten the top screws (x2) that you loosened in step 6.

8

Secure the bracket to the wall with commercially available 3.8 mm diameter wood screws with a length of 45 mm (x4) or M4 anchor bolts (x4)

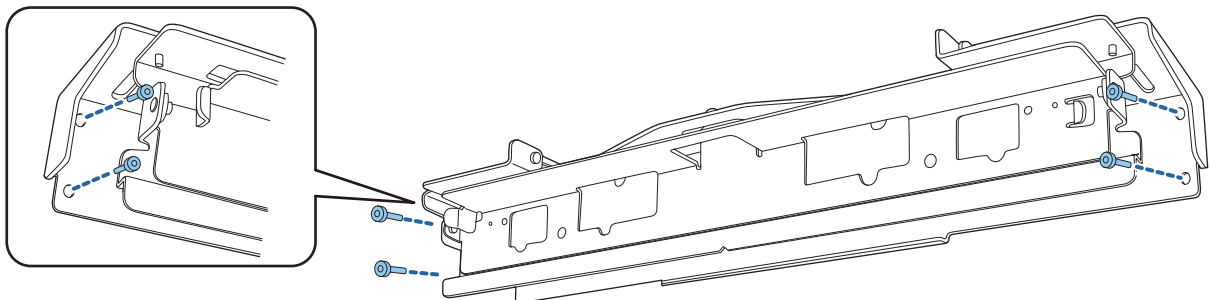

9

Slide the bracket so that it fits with the projection screen

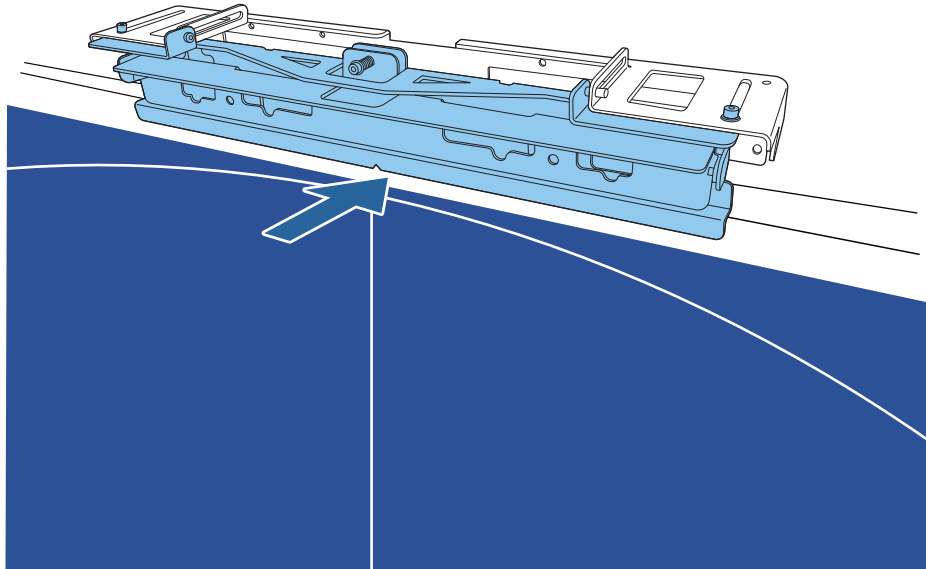

Slide it in until the lower edge of the bracket touches the projection screen.

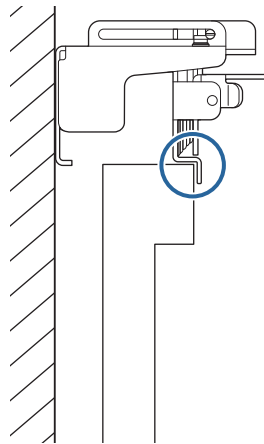

10

Remove the rubber caps (x2) from the front of the Touch Unit

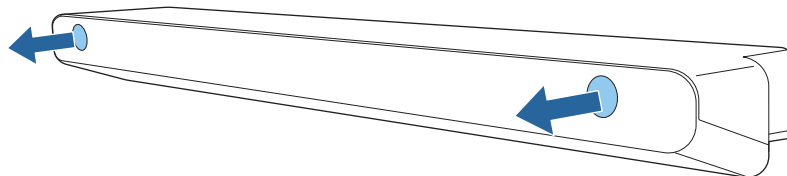

11

Secure the Touch Unit to the bracket with the M4 x 25 mm bolts (x2) supplied

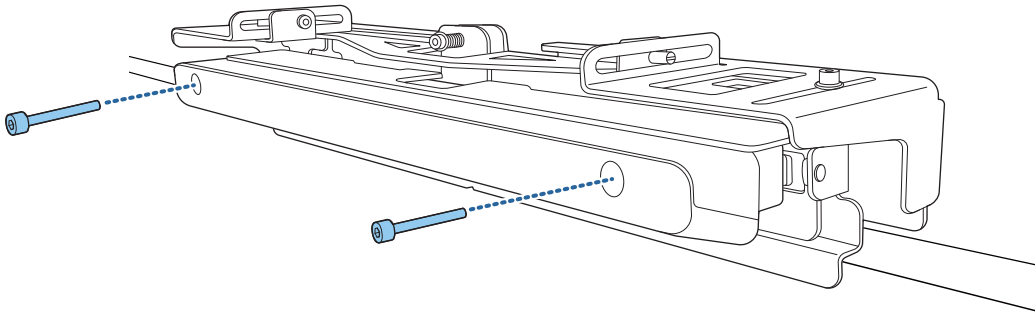

Caution

There is a powerful magnet on the rear of the Touch Unit. Do not trap your hand between the Touch Unit and the Touch Unit Bracket.

12

Attach the rubber caps that you removed in step 10 to the screw holes on the front of the Touch Unit

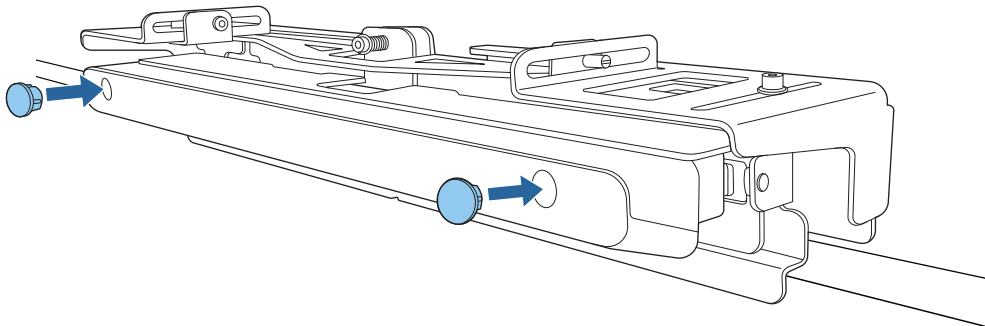

Attaching a Security Cable

The security slot on the Touch Unit is compatible with the Microsaver Security System manufactured by Kensington. See the following for more details on the Microsaver Security System.

<http://www.kensington.com/>

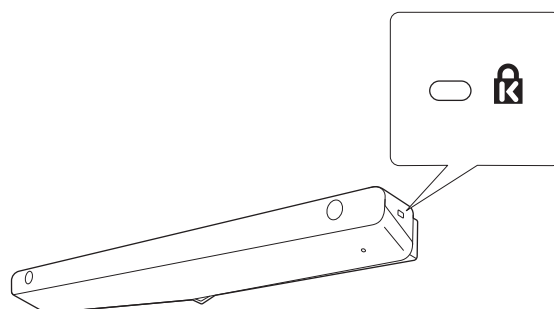

Turning on the Touch Unit

- 1 Connect the Touch Unit connection cable that is connected to the projector to the TCH port on the Touch Unit

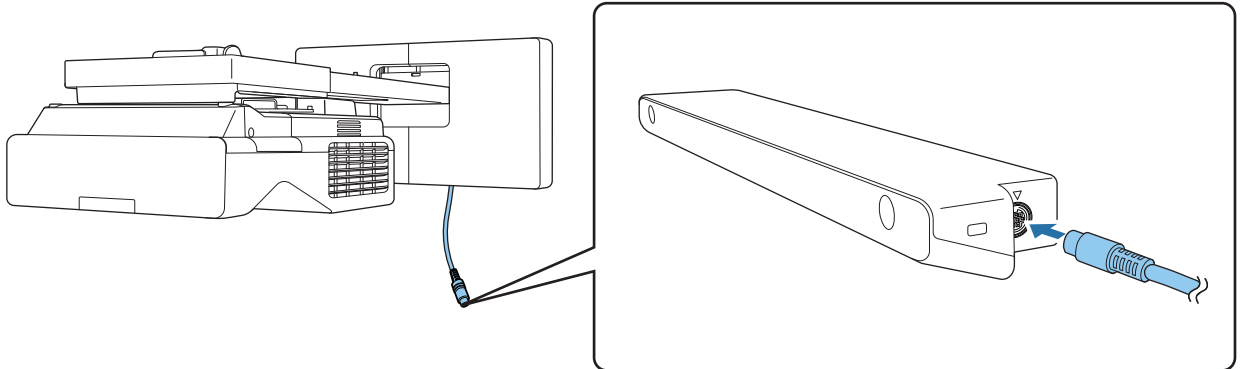

- 2 Select **Touch Unit** from the **Installation** menu

| | | |
|-----------------------|----------------------------------|-------------------|
| Frequently Used Items | Installation | |
| Image | Fixed Installation | Off |
| Signal I/O | Test Pattern | |
| Installation | Setting Plate Installation Guide | |
| Display | Vertical Installation | No |
| Operation | Projection | Front/Upside Down |
| Management | Auto Screen Adjustment | |
| Network | Geometry Correction | Point Correction |
| Pen/Touch | Digital Zoom | ▼ |
| Interactive | Connect ELPCB02 | Off |
| Memory | Touch Unit | |
| ECO | Remote Receiver | Off |
| Initial/All Settings | Projector ID | Off |
| | Screen Type | 16:9 ▼ |
| | High Altitude Mode | Off |
| | Reset Installation Settings | |
| | Display | |
| | Pattern Display | |

- 3 Set **Power** to **On**

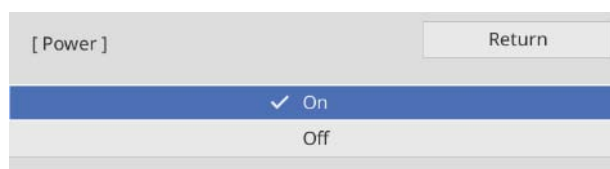

The Touch Unit turns on and the indicator is lit blue.

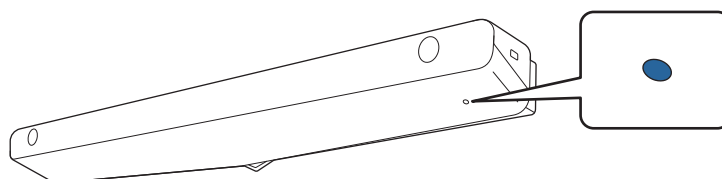

The Touch Unit automatically turns on the next time you turn on the projector if **Power** is set to **On**.

Adjusting the Angle of the Laser (Touch Unit Auto Setup)

An infrared laser in the shape of a curtain is emitted from the Touch Unit. The infrared laser reflects off your finger when touched to the projection surface thereby detecting the finger position allowing the projector's infrared camera to recognize the position being reflected.

Adjust the angle of the laser light coming from the Touch Unit so that the projector can correctly detect the position of your finger.

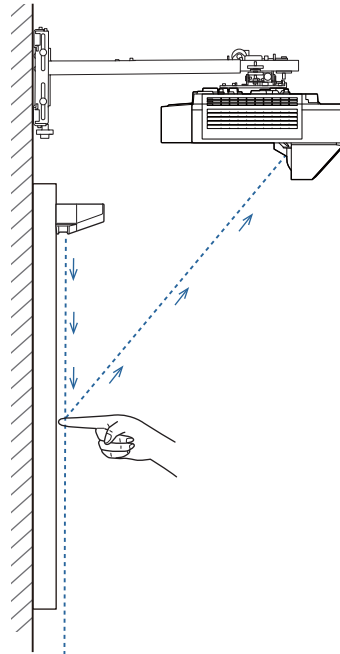

If the laser is not emitted parallel to the screen, the projector will not detect touch operations or the position of your finger correctly.

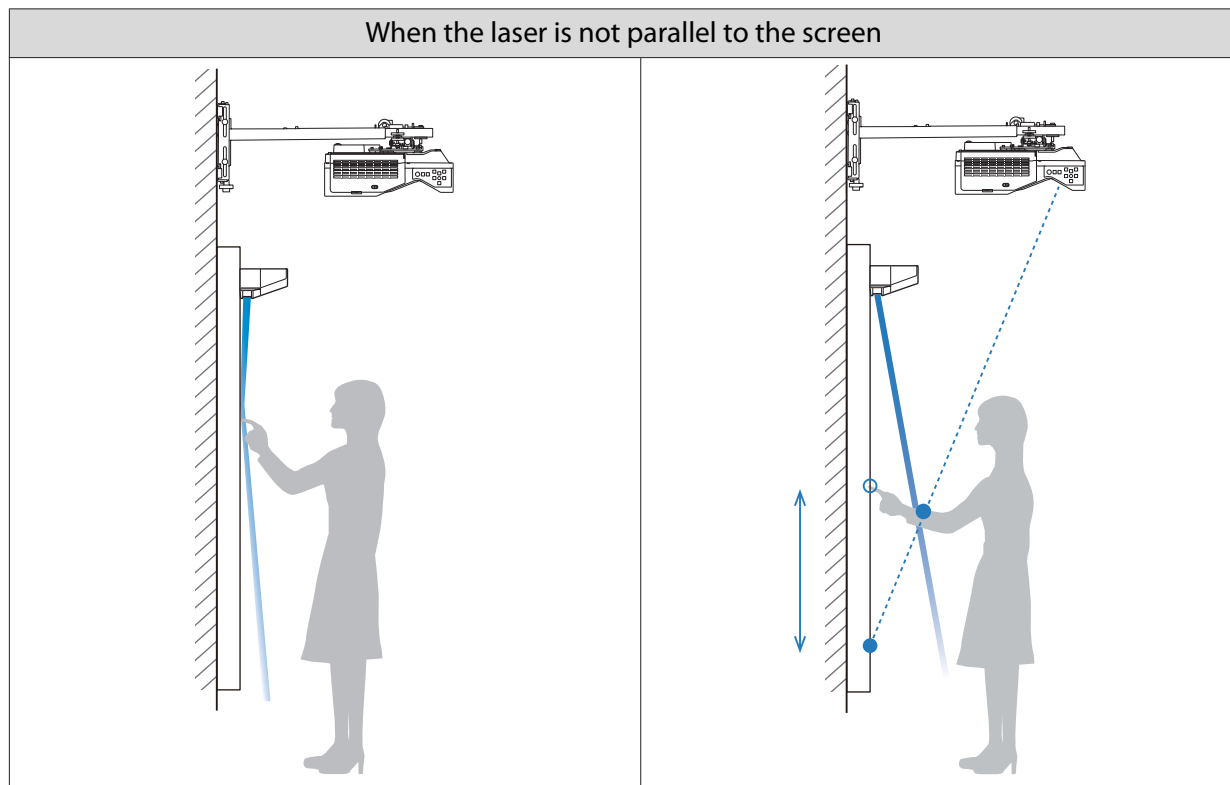

When the laser is not parallel to the screen

- The position of your finger may not be detected even if you touch the projected image.
- Even if you do not touch the projected image, touch operations may be incorrectly detected and unintended operations may be performed.
- The position of your finger detected by the projector and your actual finger position may not align, and an unintended operation may be performed.
- The projector enters a state in which a touch is still being detected, and a click operation is not recognized.



Before adjusting the angle of the laser, make sure that interactive pen calibration is complete.

1

Select **Touch Unit** from the **Installation** menu

| | | |
|-----------------------|----------------------------------|-------------------|
| Frequently Used Items | Installation | |
| Image | Fixed Installation | Off |
| Signal I/O | Test Pattern | |
| Installation | Setting Plate Installation Guide | |
| Display | Vertical Installation | No |
| Operation | Projection | Front/Upside Down |
| Management | Auto Screen Adjustment | |
| Network | Geometry Correction | Point Correction |
| Pen/Touch | Digital Zoom | ▼ |
| Interactive | Connect ELPCB02 | Off |
| Memory | Touch Unit | |
| ECO | Remote Receiver | Off |
| Initial/All Settings | Projector ID | Off |
| | Screen Type | 16:9 ▼ |
| | High Altitude Mode | Off |
| | Reset Installation Settings | |
| | Display | |
| | Pattern Display | |

2

Select **Touch Unit Setup**

| | |
|-------------------------|--------|
| [Touch Unit] | Return |
| Installation Pattern | |
| Power | On |
| Touch Unit Setup | |
| Touch Calibration | |
| Calibration Range | Wide |

3

Select whether or not the Touch Unit Bracket is being used

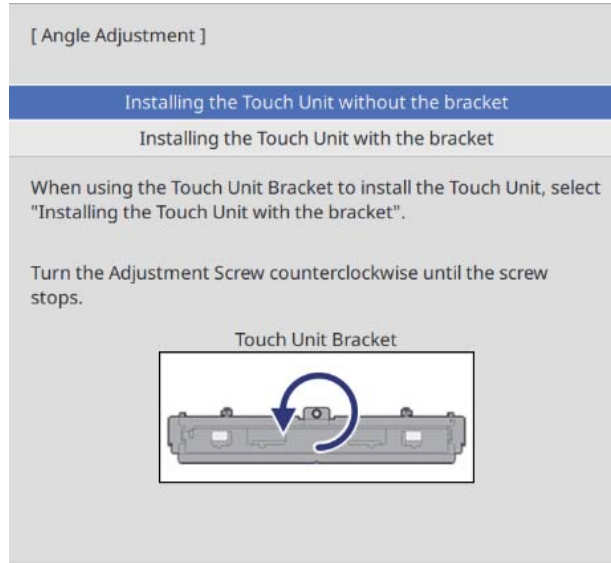

The following steps differ if you are using an older model of Touch Unit. Follow the on-screen instructions. For details on performing operations, see the *Installation Guide* supplied with the old projector.

4

If you are using the Touch Unit Bracket, turn the adjustment screw on the top of the bracket counterclockwise until you cannot turn it any further

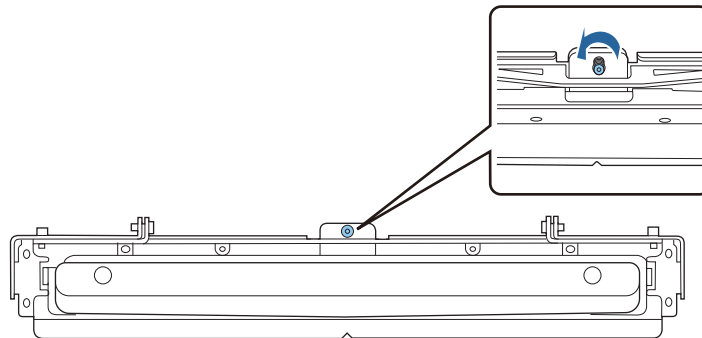

- 5 Place the two markers supplied on the marker positions on the projection screen and secure them

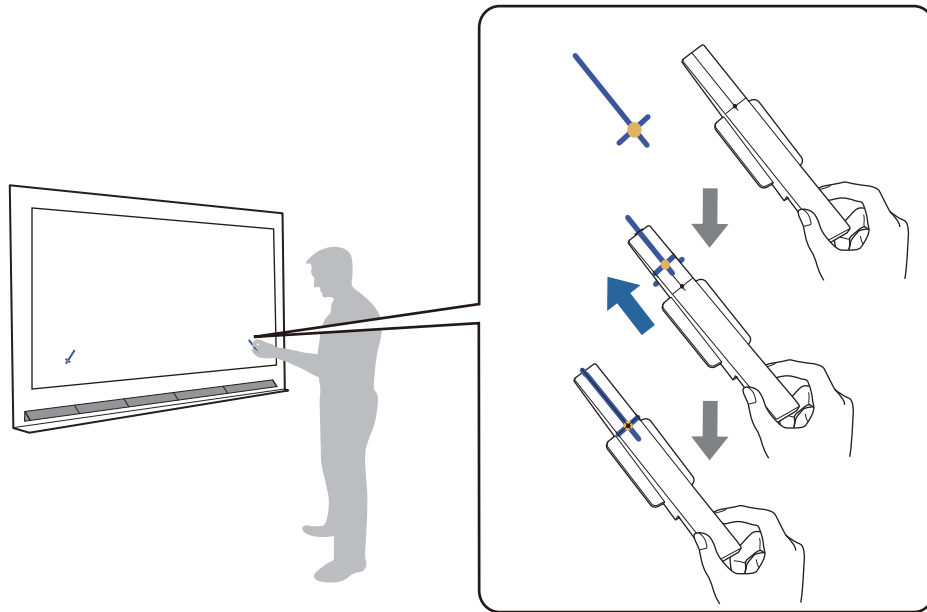

- Magnetic screens: Place the base of the markers onto the screen.
- Non-magnetic screens: Use the supplied tape to secure the markers as shown below.

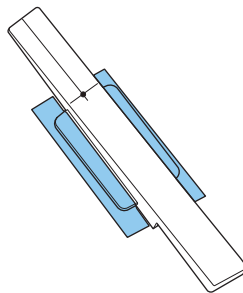

Do not place anything other than the markers near the projected image during angle adjustment. If other objects are on the projected image, angle adjustment may not be performed correctly.

6

Press the [Enter] button to start Touch Unit auto adjustment



Auto adjustment may take a few minutes depending on the projection surface.

7

When the message **Touch Unit adjustment complete.** is displayed, remove the markers from the projection surface

If you see a message notifying you that auto adjustment has failed, check "When auto adjustment fails" [p.109](#).

8 Touch (●) displayed on the screen with your finger and check if (●) is displayed in the same position

Touch all four (●) to confirm.

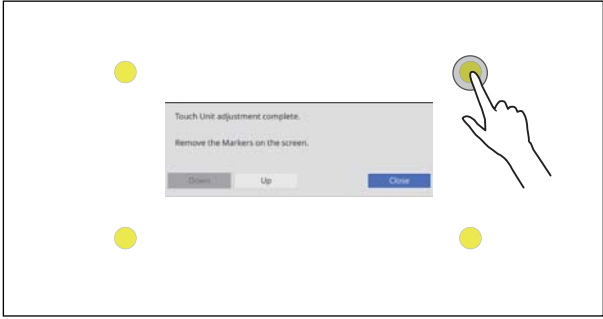
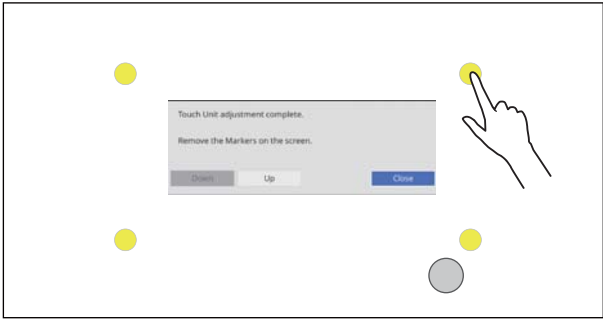
| Screen | Status |
|--|--|
|  | <p>Adjustment has been performed correctly if the location you touch with your finger is the same place as where (●) is displayed.</p> |
|  | <p>If (●) is displayed in a different location to the point you touched, select Up once using the control panel or the remote control. Next, touch (●) again with your finger to confirm.</p> <p>Repeat until (●) is displayed in the correct position.</p> |

Adjustment is complete when (●) appears in the correct position for all four (●) positions.

Go to "Calibrating the Touch Operation Position" [p.112](#).

■ When auto adjustment fails

1

Check that the Touch Unit installation position is correct

- Make sure that the Touch Unit and the projected image are parallel.

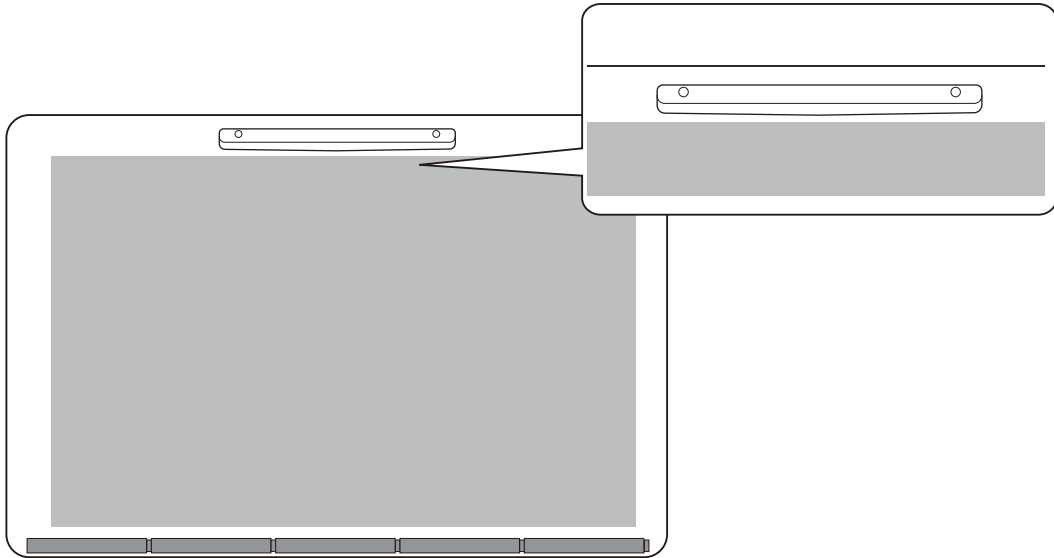

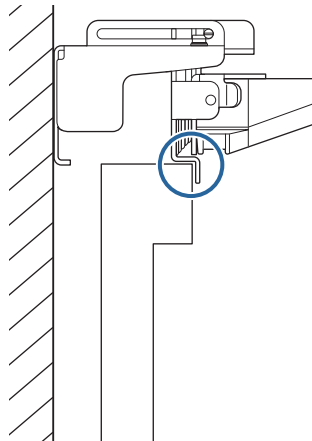

- If you are using a Touch Unit Bracket, make sure that the bottom edge of the bracket is flush with the edge of the projection surface without any gaps.

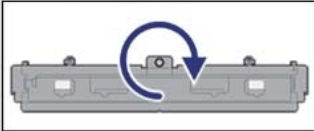

2

Check the message displayed and take the necessary action

| Screen | Solution |
|---|---|
| <p>[Touch Unit Setup]</p> <p>Auto adjustment failed.</p> <p>Step:</p> <p>1. Turn the Adjustment Screw clockwise until the screw stops before restarting.</p> <p>When this step is complete, proceed to the next step.</p> <p style="text-align: center;">Touch Unit Bracket</p>  | <p>Follow the on-screen instructions to adjust the angle of the laser, and then perform auto adjustment again. For details, see "Adjusting the angle of the laser" p.110.</p> |
| <p>Touch Unit adjustment failed.</p> <p>Remove the Markers.</p> <p>Check that there is no sunlight or strong light such as a fluorescent lamp, shining on the projection side or the interactive pen receiver, and that there are no obstructions on the screen.</p> <p>Make sure there are no obstacles in the area the icons are displayed.</p> <p>Remove all icons and restart the Touch Unit adjustment.</p> <p>If you cannot remove the icon, contact the support center.</p> <p style="text-align: center;">Close</p> | <p>Check the following after removing the markers from the projection surface.</p> <ul style="list-style-type: none"> • If you see an icon () on the projection surface, check if there are any obstacles at the position of the icon. • Check if the strong light such as sunlight or fluorescent light is shining onto the projection surface or the interactive light receiver. <p>When you have checked everything, perform Touch Unit Setup from the Installation menu.</p> |
| <p>The Touch Unit has malfunctioned.</p> <p style="text-align: right;">[0000]</p> <p style="text-align: center;">Close</p> | <p>The Touch Unit may be malfunctioning. Contact your dealer.</p> |

Adjusting the angle of the laser

This section explains how to re-adjust the laser when you see the following screen.

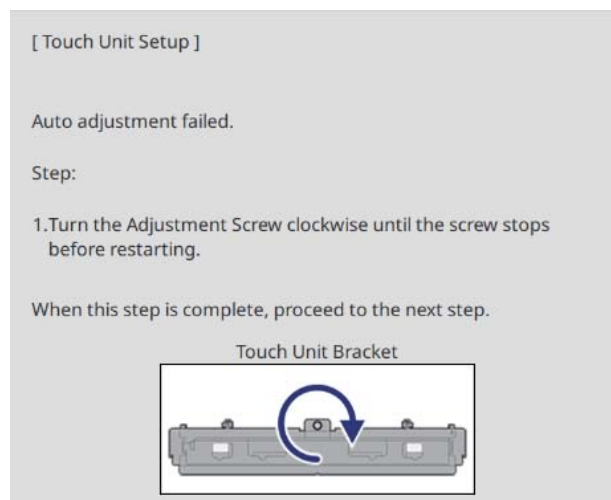

1

Press the Enter button

You see the following adjustment screen.





[Touch Unit Setup]

Step:

1. Attach the Markers to the Marker Positions. Pointers should appear.
2. If Pointers do not appear, turn the Adjustment Screw counterclockwise.
3. Turn the Adjustment Screw until the Pointers move inside of the Targets. When both Pointers turn solid, you have completed the Bracket Angle Adjustment.

Attention:

- Do not place hands or other obstacles on the screen during adjustment.
- Do not place any objects between the projector and markers during adjustment.
- When both Pointers do not turn solid, reinstall the Touch Unit Bracket correctly.

| | |
|---|---|
| Marker Position | Pointer |
|  |  |
| Adjustment Screw | Target |
|  |  |

2

Turn the adjustment screw clockwise to cover the left and right pointers

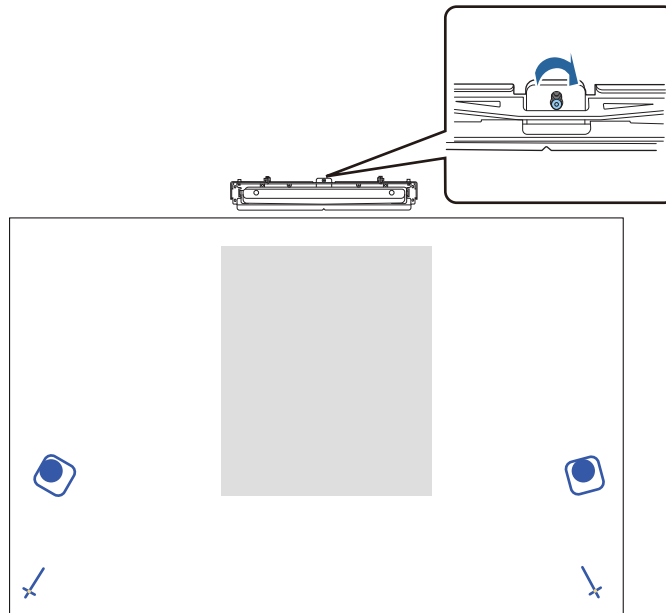

3

Press the [Enter] button to start Touch Unit auto adjustment

4 When adjustment is complete and you see the following screen, remove the markers from the projection surface



If you see a message notifying you that auto adjustment has failed, check "When auto adjustment fails" p.109.

Calibrating the Touch Operation Position

Perform touch calibration so that the projector can recognize touch operations precisely.

1 Press the projector's [Menu] button

Using the Remote Control

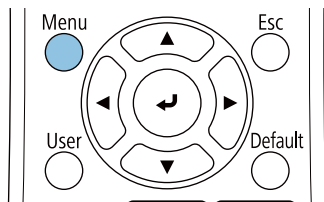

Using the Control Panel

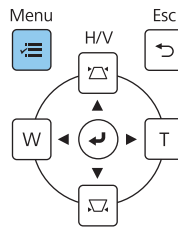

2 Select **Touch Unit** from the **Installation** menu

| | |
|-----------------------|--------------------------------------|
| Frequently Used Items | Installation |
| Image | Fixed Installation Off |
| Signal I/O | Test Pattern |
| Installation | Setting Plate Installation Guide |
| Display | Vertical Installation No |
| Operation | Projection Front/Upside Down |
| Management | Auto Screen Adjustment |
| Network | Geometry Correction Point Correction |
| Pen/Touch | Digital Zoom |
| Interactive | Connect ELPCB02 Off |
| Memory | Touch Unit |
| ECO | Remote Receiver Off |
| Initial/All Settings | Projector ID Off |
| | Screen Type 16:9 |
| | High Altitude Mode Off |
| | Reset Installation Settings |
| | Display |
| | Pattern Display |

3

Select **Touch Calibration**

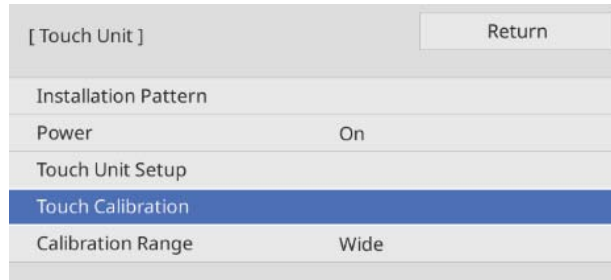

4

Select **Yes**

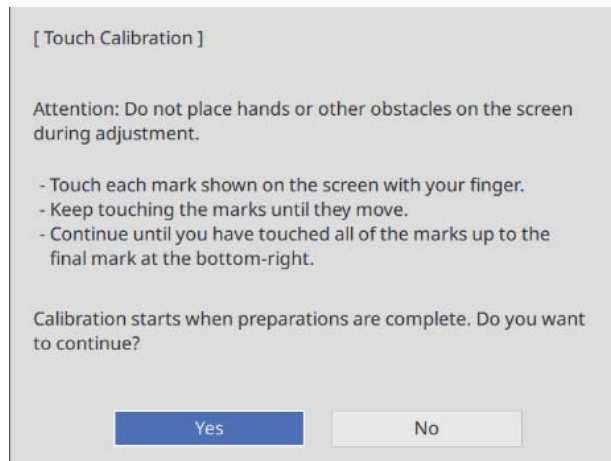

You see a dot at the top left of the projection screen.

5

Touch the center of the dot with your finger

When the dot disappears and moves to the next position, remove your finger.

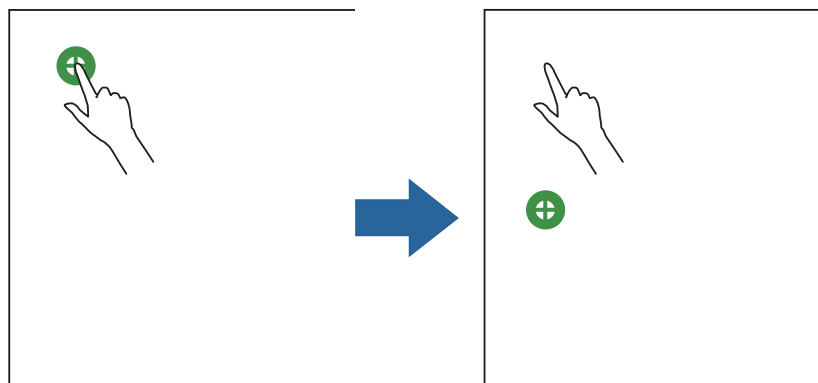

- Make sure you touch the center of the dot. Otherwise, it may not be positioned correctly.

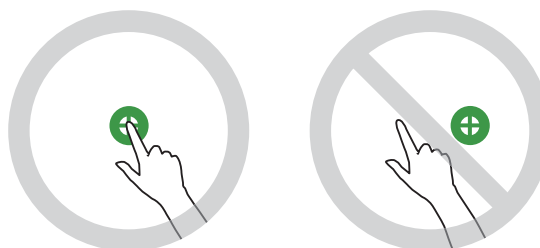

- Do not touch with anything else except the tip of your finger.

6

Repeat step 5 until all of the dots disappear

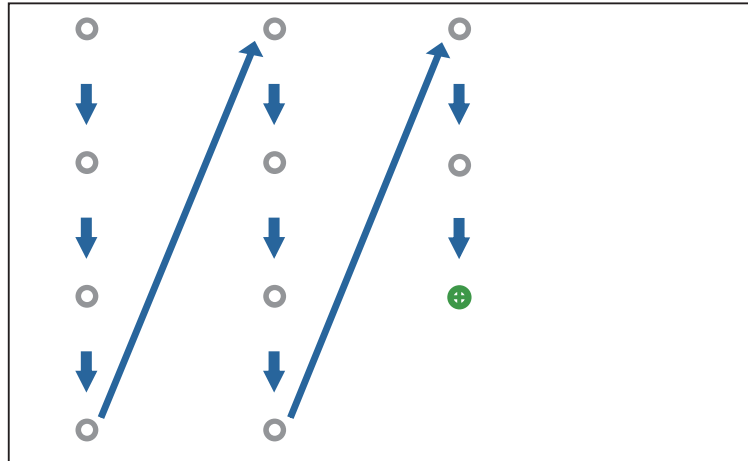

When all of the dots disappear, touch calibration is complete.



- If you touch the wrong position, press the [Esc] button on the remote control or control panel. This returns you to the previous dot. You cannot go back by two dots.
- To cancel touch calibration, hold down the [Esc] button for two seconds.
- It may take several seconds after all of the dots have disappeared until touch calibration is complete.

Batch Setup Function

After making the projector's menu settings for one projector, you can copy the settings to other projectors (batch setup function). The batch setup function is only for projectors with the same model number.

Use one of the following methods.

- Setup using a USB flash drive.
- Setup by connecting the computer and projector with a USB cable.
- Make settings using Epson Projector Management.

This guide explains the USB flash drive and the USB cable methods.

For details on making settings using Epson Projector Management, see the *Epson Projector Management Operation Guide*.



- If you do not want to copy the following settings, set **Batch Setup Range** to **Limited**.
 - **Password Protection**
 - **EDID** from the **Signal I/O** menu
 - **Network** menu
- Perform batch setup before adjusting the position of the projectors. The batch setup function copies adjustment values for the projected image such as Geometry Correction. If batch setup is performed after adjusting the position of the projectors, the adjustments you made may change.
- By using the batch setup function, the registered User's Logo is copied to the other projectors. Do not register confidential information as the User's Logo.



Caution

Performing batch setup is the customer's responsibility. If batch setup fails due to an accident such as a power failure, communication error, the customer is responsible for any repair costs incurred.

Setup Using a USB Flash Drive

This section explains how to perform batch setup using a USB flash drive.



- Use a FAT format USB flash drive.
- The batch setup function cannot be used by USB flash drives that incorporate security functions. Use a USB flash drive that does not incorporate security functions.
- The batch setup function cannot be used by USB card readers or USB hard disks.

Saving settings to the USB flash drive

1

Disconnect the power cord from the projector, and check that all of the projector's indicators have turned off

2

Connect the USB flash drive to the projector's USB-A port



- Connect the USB flash drive directly to the projector. If the USB flash drive is connected to the projector through a USB hub, the settings may not be saved correctly.
- Connect an empty USB flash drive. If the USB flash drive contains data other than the batch setup file, the settings may not be saved correctly.

3

While holding down the [Esc] button on the remote control or the control panel, connect the power cord to the projector

The On/Standby indicator and the Status indicator turn blue, and the Laser indicator and the Temp indicator turn orange.

When all of the projector's indicators turn on, release the [Esc] button.

On/Standby 

Status 

Laser 

Temp 

When all of the indicators start flashing, the batch setup file is being written.



Caution

- Do not disconnect the power cord from the projector while the file is being written. If the power cord is disconnected, the projector may not start correctly.
- Do not disconnect the USB flash drive from the projector while the file is being written. If the USB flash drive is disconnected, the projector may not start correctly.

When writing completes normally, the projector turns off, and only the On/Standby indicator is lit blue.

On/Standby 

Status 

Laser 

Temp 

When the power turns off, remove the USB flash drive.



- The file name for the batch setup file is PJCONFDATA.bin. If you need to change the file name, add text after PJCONFDATA. If you change the PJCONFDATA section of the file name, the projector may not be able to recognize the file correctly.
- You can only use single-byte characters for the file name.

■ Copying saved settings to other projectors

1 Disconnect the power cord from the projector, and check that all of the projector's indicators have turned off

2 Connect the USB flash drive containing the saved batch setup file to the projector's USB-A port



Do not store any data except for the batch setup file on the USB flash drive. If the USB flash drive contains data other than the batch setup file, the settings may not be copied correctly.

3 While holding down the [Menu] button on the remote control or the control panel, connect the power cord to the projector

The On/Standby indicator and the Status indicator turn blue, and the Laser indicator and the Temp indicator turn orange.

When all of the projector's indicators turn on, release the [Menu] button. The indicators turn on for approximately 75 seconds.

On/Standby

Status

Laser

Temp

When all of the indicators start flashing, the settings are being written.



Caution

- Do not disconnect the power cord from the projector while the settings are being written. If the power cord is disconnected, the projector may not start correctly.
- Do not disconnect the USB flash drive from the projector while the settings are being written. If the USB flash drive is disconnected, the projector may not start correctly.

When writing completes normally, the projector turns off, and only the On/Standby indicator is lit blue.

On/Standby

Status

Laser

Temp

When the power turns off, remove the USB flash drive.

Setup by Connecting the Computer and Projector with a USB Cable



The following operating systems support the batch setup function.

- Windows 7 and later
- OS X 10.11 and later

■ Saving settings to a computer

- 1 Disconnect the power cord from the projector, and check that all of the projector's indicators have turned off
- 2 Connect the computer's USB port to the projector's USB-B1 port with a USB cable
- 3 While holding down the [Esc] button on the remote control or the control panel, connect the power cord to the projector

The On/Standby indicator and the Status indicator turn blue, and the Laser indicator and the Temp indicator turn orange.

When all of the projector's indicators turn on, release the [Esc] button.

On/Standby  

Status  

Laser  

Temp  

The projector is recognized as a removable disk by the computer.

- 4 Open the removable disk, and save the batch setup file (PJCONFDATA.bin) to the computer



If you need to change the name of the batch setup file, add text after PJCONFDATA. If you change the PJCONFDATA section of the file name, the projector may not be able to recognize the file correctly. You can only use single-byte characters for the file name.

5

Perform "Remove USB device" on your computer, and then disconnect the USB cable



When using a Mac, perform "Remove EPSON_PJ".

The projector turns off, and only the On/Standby indicator is lit blue.

On/Standby 

Status 

Laser 

Temp 

■ Copying saved settings to other projectors

1

Disconnect the power cord from the projector, and check that all of the projector's indicators have turned off

2

Connect the computer's USB port to the projector's USB-B1 port with a USB cable

3

While holding down the [Menu] button on the remote control or the control panel, connect the power cord to the projector

The On/Standby indicator and the Status indicator turn blue, and the Laser indicator and the Temp indicator turn orange.

When all of the projector's indicators turn on, release the [Menu] button.

On/Standby 

Status 

Laser 

Temp 

The projector is recognized as a removable disk by the computer.

4

Copy the batch setup file (PJCONFDATA.bin) that you saved to your computer to the top-level folder of the removable disk



Do not copy any files or folders other than the batch setup file to the removable disk.

5 Perform "Remove USB device" on your computer, and then disconnect the USB cable





 When using a Mac, perform "Remove EPSON_PJ".

When all of the indicators start flashing, the settings are being written.









 **Caution**

Do not disconnect the power cord from the projector while the settings are being written. If the power cord is disconnected, the projector may not start correctly.

When writing completes normally, the projector turns off, and only the On/Standby indicator is lit blue.

- On/Standby 
- Status 
- Laser 
- Temp 

When Setup Fails

| Check | Remedy |
|--|--|
| <p>Are the Laser and the Temp indicators flashing orange quickly?</p> <p>On/Standby  <input checked="" type="checkbox"/></p> <p>Status  <input checked="" type="checkbox"/></p> <p>Laser  <input checked="" type="checkbox"/></p> <p>Temp  <input checked="" type="checkbox"/></p> | <p>The batch setup file may be corrupt, or the USB flash drive or USB cable may not be connected correctly. Disconnect the USB flash drive or the USB cable, unplug and then plug in the projector's power cord, and then try again.</p> |
| <p>Are the On/Standby and the Status indicators flashing blue, and the Laser and the Temp indicators flashing orange quickly?</p> <p>On/Standby  <input checked="" type="checkbox"/></p> <p>Status  <input checked="" type="checkbox"/></p> <p>Laser  <input checked="" type="checkbox"/></p> <p>Temp  <input checked="" type="checkbox"/></p> | <p>Writing the settings may have failed and an error may have occurred in the projector's firmware. Stop using the projector, remove the power plug from the electrical outlet, and contact Epson for help.</p> |

Installing Multiple Projectors (Multi-Projection)

You can create one horizontally long screen as a unified image projected from multiple projectors.

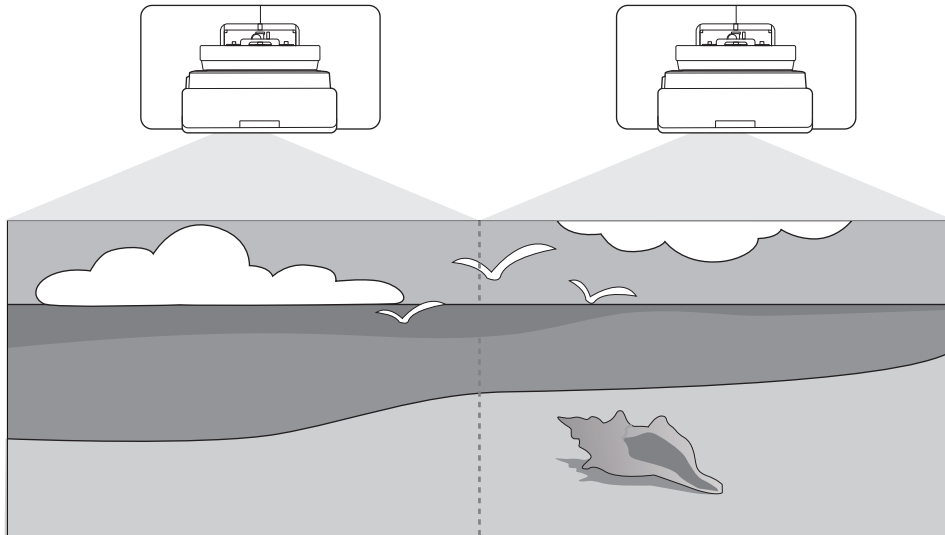

When performing multi-projection, make connections and the necessary settings in the following order.



When setting Multi-Projection, we recommend setting **Operation** > **Sleep Mode** to **Off** from the projector's Menu.

- 1 Setting the Projector ID (👉 p.121)
- 2 Multi-Projection image adjustment (👉 p.123)
- 3 Projector Sync. Settings (👉 p.124)

Setting the Projector ID

1

Turn on the projector, and then press the [Menu] button

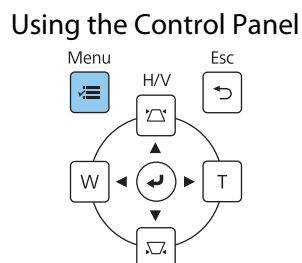
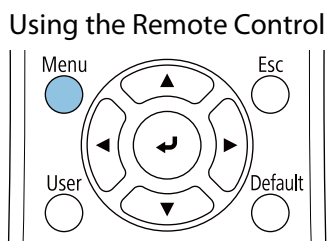

2 Select **Projector ID** from the **Installation** menu



3 Select the ID number for the projector



- 4 Press the [Esc] button to close the menu
- Repeat steps 1 to 4 for the remaining projectors.

- 5 Point the remote control at the projector you want to operate, and then press the [ID] button

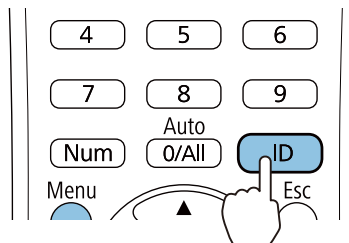

The current ID number is displayed on the projection screen.

- While holding down the [ID] button, press the button with the same number as the projector ID for the projector you want to operate

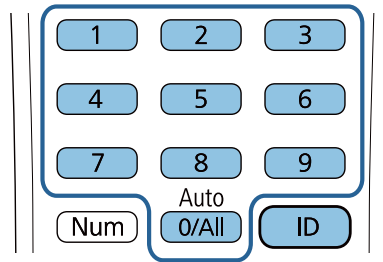

Remote control operations for the projector with the selected ID are enabled.



- When **Projector ID** is set to **Off**, you can operate the projector using the remote control regardless of the ID setting selected using the remote control.
- When the remote control ID is set to 0, you can operate all of the projectors regardless of the projector ID setting.
- Operating multiple remote controls at the same time can cause accidental operations due to infrared interference.

Adjusting the Image in Multi-Projection



Images are not stable immediately after turning on the projector. After starting projection, wait for at least 30 minutes before adjusting the image.

When using the EB-735Fi/EB-725Wi

- Turn on the projector

- Press the [Menu] button

Using the Remote Control

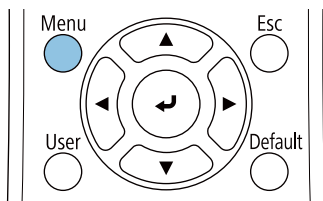

Using the Control Panel

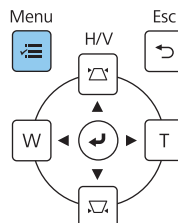

3 Make the necessary settings from the following menus

For details on making settings, see the projector's *User's Guide*.

| | |
|---|---|
| <p>Image - Color Mode (Press the [Color Mode] button on the remote control to execute)</p> | <p>Select the same item for each projector so that the color of the entire image looks uniform.</p> |
| <p>Operation - Light Source Brightness Control - Light Source Mode</p> | <p>Adjust the brightness of the entire image. Select Custom, and then adjust the Brightness Level based on the darkest projector.</p> |
| <p>Management - Color Uniformity Image - RGBCMY</p> | <p>Adjust the color of the image for each projector so that the entire image looks uniform.</p> |

Projector Sync. Settings (only when using interactive functions)

Connect the projectors in advance by using the remote control cable set (ELPKC28). For details, see "Connecting Multiple Projectors" p.15.

1 Press the [Menu] button

Using the Remote Control

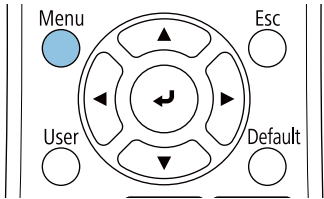

Using the Control Panel

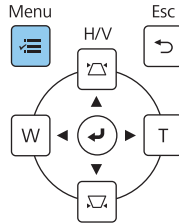

2 Select **Installation of Projectors** from the **Pen/Touch** menu

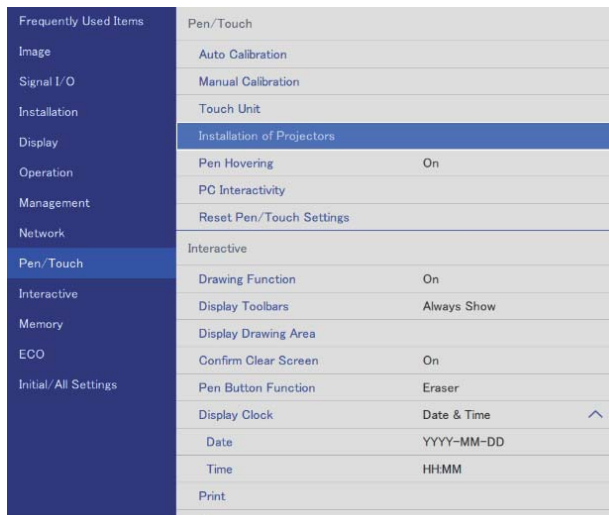

3 Select **Sync of Projectors**

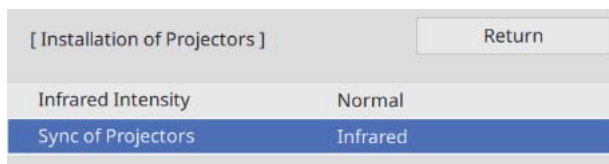















4













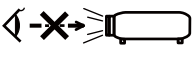

Select **Wired**



List of Safety Symbols

The following table lists the meaning of the safety symbols labeled on the equipment.

| Symbol mark | Approved standards | Meaning |
|---|-------------------------------------|---|
|  | IEC60417 No.5007 | Power On To indicate connection to the mains. |
|  | IEC60417 No.5008 | Power Off To indicate disconnection from the mains. |
|  | IEC60417 No.5009 | Standby To identify the switch or switch position by means of which part of the equipment is switched on in order to bring it into the standby condition. |
|  | ISO7000 No.0434B IEC3864-B3.1 | Caution To identify general caution when using the product. |
|  | IEC60417 No.5041 | Caution, hot surface To indicate that the marked item can be hot and should not be touched without taking care. |
|  | IEC60417 No.6042 ISO3864-B3.6 | Caution, risk of electric shock To identify equipment that presents a risk of electric shock. |
|  | IEC60417 No.5957 | For indoor use only To identify electrical equipment designed primarily for indoor use. |
|  | IEC60417 No.5926 | Polarity of d.c. power connector To identify the positive and negative connections (the polarity) on a piece of equipment to which a d.c. power supply may be connected. |
|  | --- | |
|  | IEC60417 No.5001B | Battery, general On battery powered equipment. To identify a device for instance a cover for the battery compartment, or the connector terminals. |
|  | IEC60417 No.5002 | Positioning of battery To identify the battery holder itself and to identify the positioning of the batteries inside the battery holder. |
|  | --- | |
|  | IEC60417 No.5019 | Protective earth To identify any terminal which is intended for connection to an external conductor for protection against electric shock in case of a fault, or the terminal of a protective earth electrode. |
|  | IEC60417 No.5017 | Earth To identify an earth (ground) terminal in cases where the  is not explicitly required. |

| Symbol mark | Approved standards | Meaning |
|---|---------------------------------|--|
|  | IEC60417 No.5032 | Alternating current To indicate that the equipment is suitable for alternating current only; to identify relevant terminals. |
|  | IEC60417 No.5031 | Direct current To indicate that the equipment is suitable for direct current only; to identify relevant terminals. |
|  | IEC60417 No.5172 | Class II equipment To identify equipment meeting the safety requirements specified for Class II equipment according to IEC 61140. |
|  | ISO 3864 | General prohibition To identify actions or operations that are prohibited. |
|  | ISO 3864 | Contact prohibition To indicate injury that could occur due to touching a specific part of the equipment. |
|  | --- | Never look into the projection window while the projector is on. |
|  | --- | To indicate that you must never place anything on the projector. |
|  | ISO3864 IEC60825-1 | Caution, laser radiation To indicate the equipment has a laser radiation part. |
|  | ISO 3864 | Disassembly prohibition To indicate a risk of injury, such as electric shock, if the equipment is disassembled. |
|  | IEC60417 No.5266 | Standby, partial standby To indicate that part of the equipment is in the ready status. |
|  | ISO3864 IEC60417 No.5057 | Caution, movable parts To indicate that you must keep away from movable parts according to protection standards. |
|  | IEC 60417-6056 | Caution, movable fan blades To indicate that you must keep away from the blades of the movable fan according to protection standards. |
|  | IEC 60417-6043 | Caution, sharp corners To indicate that you must not touch the sharp corners of the product according to protection standards. |
|  | -- | Never look into the projection window while the projector is on. |
|  | ISO7010 No. W027 ISO 3864 | Warning, light emission (UV, visible light, IR and so on) To indicate that you must be careful not to injure your eyes or skin when near light emitting sections. |
|  | IEC60417 No.5109 | Not to be used in residential areas To indicate that the electrical equipment/device is not suitable for use in a residential area. |

Indication of the manufacturer and the importer in accordance with requirements of directive 2011/65/ EU (RoHS)

Manufacturer: SEIKO EPSON CORPORATION

Address: 3-5, Owa 3-chome, Suwa-shi, Nagano-ken 392-8502 Japan

Telephone: 81-266-52-3131

<http://www.epson.com/>

Importer: SEIKO EUROPE B.V.

Address: Azië building, Atlas Arena, Hoogoorddreef 5, 1101 BA Amsterdam Zuidoost The Netherlands

Telephone: 31-20-314-5000

<http://www.epson.eu/>

General Notice

Mac and OS X are trademarks of Apple Inc.

Microsoft and Windows are trademarks or registered trademarks of Microsoft Corporation in the United States and/or other countries.

© 2020 Seiko Epson Corporation
2020.05 413966400ENPDF

Free Manuals Download Website

<http://myh66.com>

<http://usermanuals.us>

<http://www.somanuals.com>

<http://www.4manuals.cc>

<http://www.manual-lib.com>

<http://www.404manual.com>

<http://www.luxmanual.com>

<http://aubethermostatmanual.com>

Golf course search by state

<http://golfingnear.com>

Email search by domain

<http://emailbydomain.com>

Auto manuals search

<http://auto.somanuals.com>

TV manuals search

<http://tv.somanuals.com>