

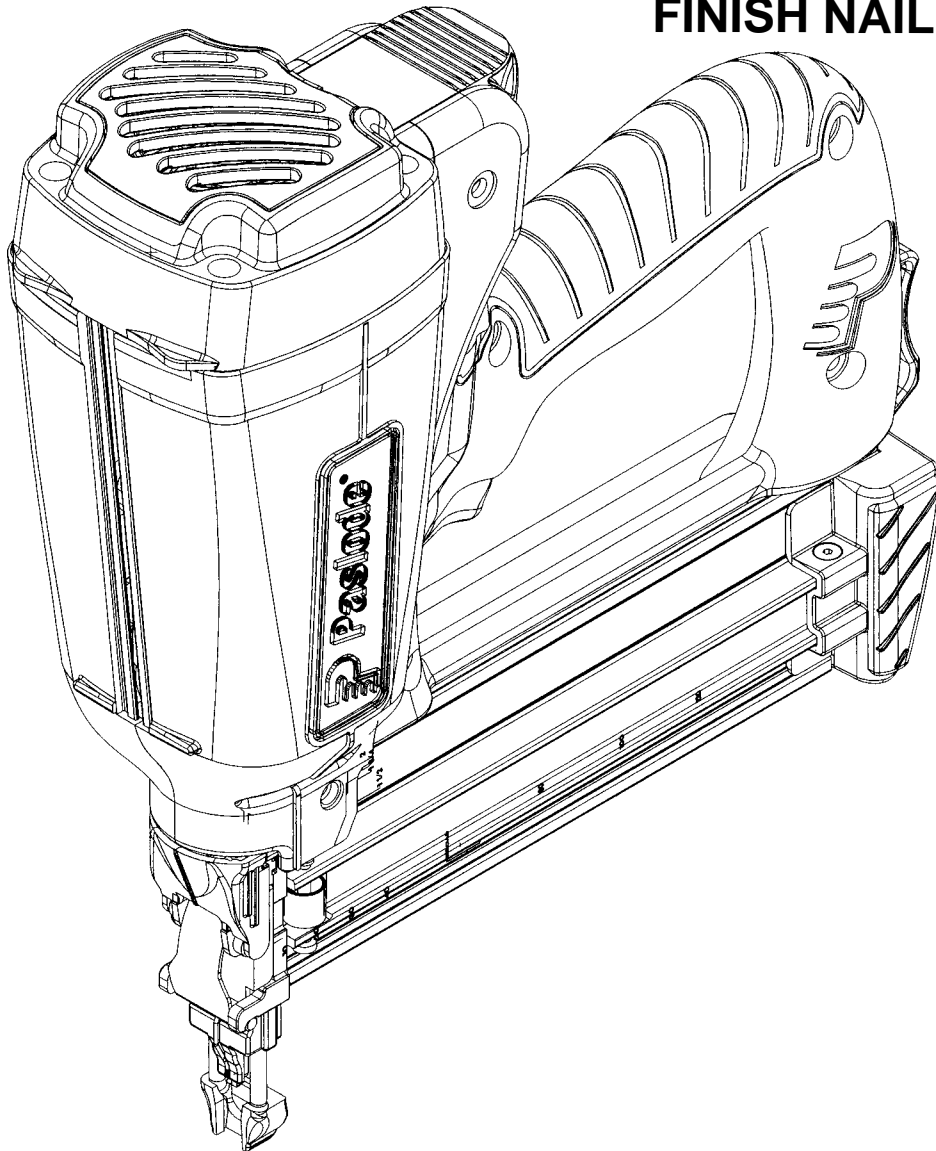

Model: IM200 F18
Part No. 901000
18 Gauge Finish Nailer

18 GAUGE CORDLESS FINISH NAILER



IMPORTANT! DO NOT DESTROY

It is the customer's responsibility to have all operators and service personnel read and understand this manual.

OPERATING MANUAL

<i>Subject</i>	<i>Page</i>
Introduction and Warranty	2
An Overview of TrimMaster18™ Finish Nailer	3
Safety Instructions	4
Battery and Charger	7
Fuel Cell and Metering Valve	9
Preparing TrimMaster 18™ Finish Nailer for Use	12
TrimMaster 18™ Finish Nailer Operation	13
Fasteners and Applications	14
Servicing	15
Troubleshooting	17

The Impulse® battery charger system meets all safety requirements for power tools.



 **Paslode**® is a trademark
Paslode
An Illinois Tool Works Company
888 Forest Edge Drive
Vernon Hills, Illinois 60061
www.paslode.com

 **Paslode**®
CORDLESS Power Nailers are made in the U.S.A. and are protected by one or more of the following U.S. patents:*

4,403,722 4,483,280 4,483,474 4,522,162

*Other patents issued and pending.

Paslode® is a member of:



Introduction and Warranty

TrimMaster 18™ Finish Nailer Operating Manual

This manual is intended to acquaint you with the Paslode Cordless 18 Finish Nailer. Unlike other power fastening tools, the Cordless 18 Finish Nailer is powered by an internal combustion linear motor. In simpler terms, your Cordless 18 Finish Nailer is powered by a motor similar to the one that powers an automobile. The Cordless 18 Finish Nailer ignites a fuel and air mixture to produce the energy to drive the motor, which in turn drives the fastener. The Cordless 18 Finish Nailer is totally self-contained. It carries its own fuel supply and battery, along with a supply of fasteners.

For ease of use, this manual is divided into sections (see Contents). Each section of the manual is written with you, the tool operator, in mind. We have left out many of the technical terms so that you can easily understand how to get the maximum performance from your Cordless 18 Finish Nailer, and how to avoid damaging the tool or injuring yourself. But, to accomplish this, we need you to do two things:

1. READ THE MANUAL FROM COVER TO COVER BEFORE USING THE TOOL.

2. FOLLOW ALL INSTRUCTIONS IN THE MANUAL.

The Finish nailer should be handled like other power fastening tools that you use. Like most tools, when used improperly injury could result. If you are going to allow others to use the Finish nailer, it is your responsibility to make sure that they also read and comply with the instructions in this manual before attempting to operate the tool.

Should you have questions about the Finish nailer, or wish to obtain additional copies of this manual, please contact your Paslode® representative. The space below is provided so that you may record your representative's name, address, and telephone number.

For the nearest Paslode representative call 1-800-682-3428

Name

Address

City

State

Zip

Telephone Number

Cordless Warranty and Limitations

Paslode warranties that new Cordless power fastening tools, parts and accessories will be free from defects in material and workmanship for the period shown below, after the date of delivery to the original user.

ONE-YEAR LIMITED WARRANTY

A one-year warranty will apply to all parts, except those listed below as normal wearing parts, or parts which are specifically covered by an extended warranty.

FIVE-YEAR EXTENDED LIMITED WARRANTY

A five-year warranty will apply to all molded nylon parts:

- Cap and Grille
- Handle Halves and Actuator
- Trigger

90-DAY LIMITED WARRANTY

A 90-day warranty applies to the following parts, which are considered normal wear parts:

- Bumper
- Driver Blades
- O-Rings

WARRANTY STATEMENT

Paslode's sole liability hereunder will be to replace any part or accessory which proves to be defective within the specific time period. Any replacement part or accessory provided in accordance with this warranty will carry a warranty for the balance of the period of warranty applicable to the part it replaces. This warranty does not apply to part replacement required due to normal wear.

This warranty is void on any tool which has been subjected to misuse, abuse, accidental or intentional damage, use with fasteners, fuel, batteries, or battery chargers not meeting Paslode specification, size, or quantity, improperly maintained, repaired with other than genuine Paslode replacement parts, damaged in transit or handling, or which, in Paslode's opinion, has been altered or repaired in a way that affects or detracts from the performance of the tool.

PASLODE MAKES NO WARRANTY, EXPRESSED OR IMPLIED, RELATING TO MERCHANTABILITY, FITNESS, OR OTHERWISE, EXCEPT AS STATED ABOVE, and Paslode's liability AS STATED ABOVE AND AS ASSUMED ABOVE is in lieu of all other warranties arising out of, or in connection with, the use and performance of the tool, except to the extent otherwise provided by applicable law. PASLODE SHALL IN NO EVENT BE LIABLE FOR ANY DIRECT, INDIRECT, OR CONSEQUENTIAL DAMAGES, INCLUDING, BUT NOT LIMITED TO, DAMAGES WHICH MAY ARISE FROM LOSS OF ANTICIPATED PROFITS OR PRODUCTION, SPOILAGE OF MATERIALS, INCREASED COST OF OPERATION, OR OTHERWISE.

An Overview of the Cordless TrimMaster 18™ Finish Nailer

Description

The TrimMaster 18™ Finish nailer is a self-contained, fully portable nailer that uses liquid hydrocarbon fuel to power a unique linear drive internal combustion motor.

In order for you to fully understand the information contained in this manual, you need a basic understanding of the TrimMaster 18™ Finish nailer. As you can see in the illustration below, the Impulse Finish nailer is made up of three major areas: handle, motor, and magazine.

As you examine the TrimMaster 18™ Finish nailer, become familiar with the three major areas and the various components located in each of them.

The **Handle** contains the fuel cell, indicator light, and the trigger.

The **Motor** contains the cover and filter, the motor housing, the nose, and the work contacting element.

The **Magazine** contains the components to load and control the fastener and the battery for the Cordless 18 Finish nailer.

Specifications

Dimensions:	Weight-with battery	4 lbs 14oz.
	Height	11-1/2 inches
	Length	11 inches
	Magazine	Straight 18 Ga.

Cycle Rate:	Intermittent Operation – 2 to 3 nails per second
	Continuous Operation – 500 nails per hour

NOTE: Exceeding these cycle rates could cause the tool to overheat, resulting in loss of performance or damage to tool components.

By using the TrimMaster 18™ Finish nailer at its recommended cycle rate, you will be able to drive several thousand nails in a typical workday.

Fasteners: 18 gauge, straight F-18 Series, Chisel Point

Magazine Capacity: 2 nail strips, or 100 fasteners



Battery : 6 volts DC - Provides enough energy to drive approximately 4000 fasteners on a full charge.

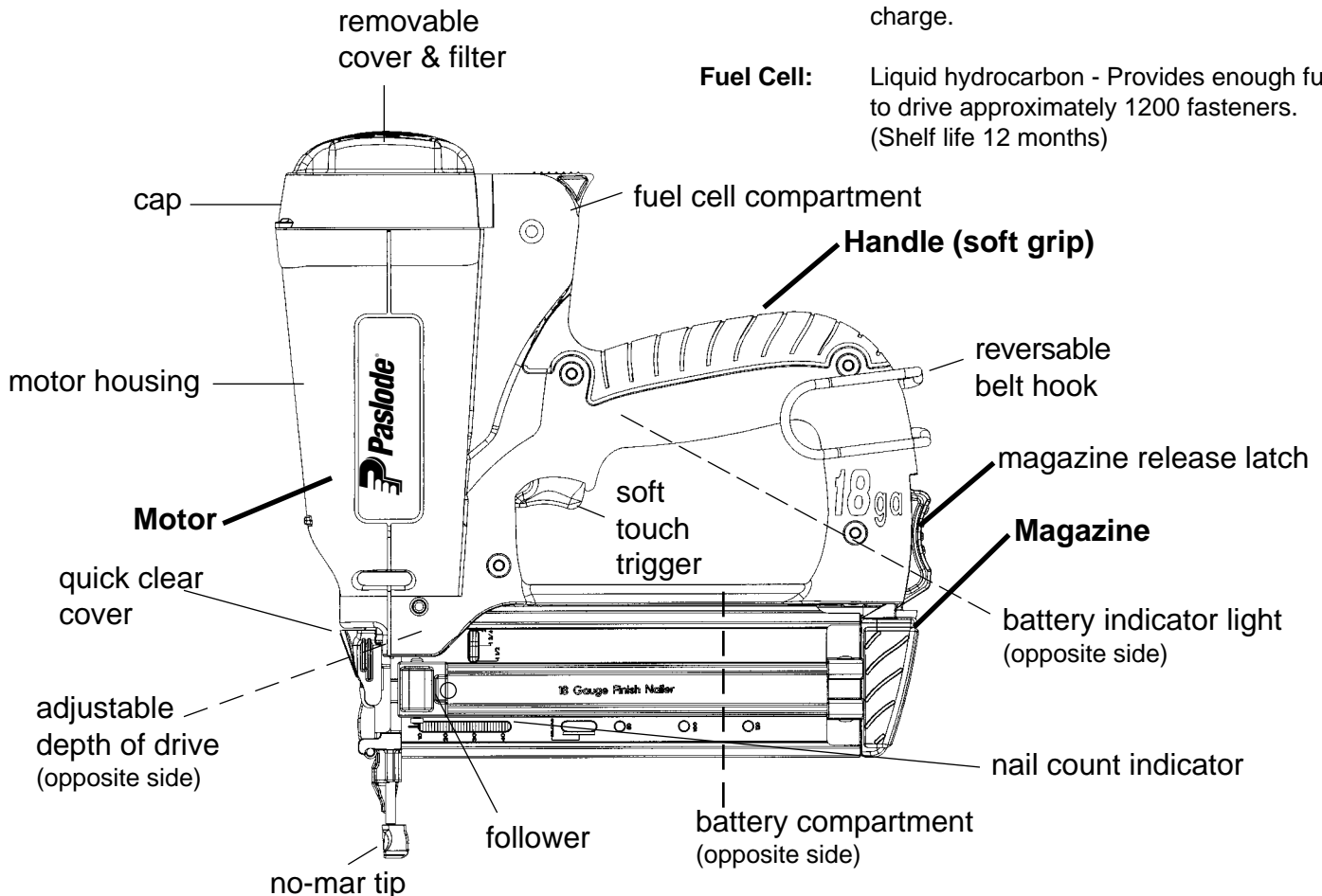

Fuel Cell: Liquid hydrocarbon - Provides enough fuel to drive approximately 1200 fasteners. (Shelf life 12 months)





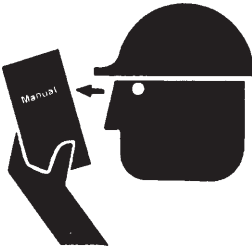

Safety Instructions

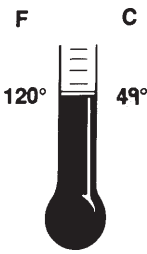

The following safety instructions have been included in this booklet to provide you with basic information necessary for safe operation of the TrimMaster 18™ Finish Nailer. **DO NOT ATTEMPT TO OPERATE THIS TOOL UNTIL YOU HAVE READ AND UNDERSTAND ALL SAFETY PRECAUTIONS AND MANUAL INSTRUCTIONS.**

	 DANGER
	<p>The TrimMaster 18™ Finish Nailer is an internal combustion device. It produces hot exhaust gases that may ignite flammable materials. This tool must not be used in a combustible environment or in the presence of combustible materials, such as flammable chemicals, adhesives, gasoline, or solvents.</p>

	 WARNING
	<p>Do not attempt to operate this tool until you have read and understood all safety precautions and manual instructions. Failure to follow all safety precautions and instructions may result in a permanent loss of vision, serious personal or even fatal injury, property damage and/or tool damage.</p>

	 WARNING
	<p>Do not expose the tool to temperatures in excess of 120° F (49° C). Fuel and/or the battery may burst, releasing flammable gas.</p>

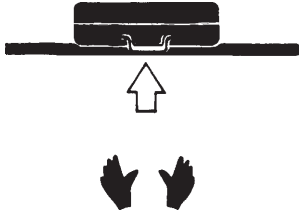
	 WARNING
	<p>This tool must be operated only in a well-ventilated environment, because the tool exhausts carbon monoxide similar to a gas chainsaw or lawnmower. Exposure to carbon monoxide may cause dizziness, nausea, or unconsciousness.</p>

	 WARNING
	<p>ALWAYS keep the TrimMaster 18™ Finish Nailer, fuel cell, battery and battery charger out of the reach of children.</p>

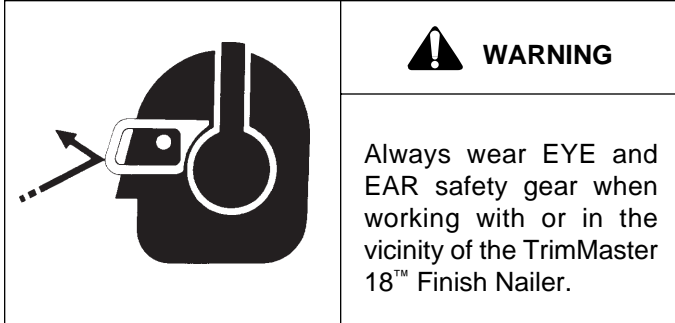

1. Eye protection must meet the requirements of ANSI Standard Z87.1 and should have side shields for increased protection.
2. NEVER ASSUME THE TOOL IS EMPTY.
Never point the tool at yourself or anyone else.
3. NEVER ENGAGE IN "HORSEPLAY" WITH THE TOOL.
The TrimMaster18™ Finish Nailer is not a toy – it is a tool. Careless and improper use may result in a serious accident.
4. NEVER CARRY THE TOOL WITH YOUR FINGER ON, OR SQUEEZING, THE TRIGGER.
This practice may result in the accidental discharge of a fastener.
5. NEVER OPERATE A MALFUNCTIONING TOOL.
Refer to the servicing or troubleshooting section of this manual to correct the problem. If the problem cannot be corrected, stop using the tool and report it to your supervisor or Paslode® representative.
6. DO NOT LOAD FASTENERS WITH THE TRIGGER AND/OR WORK CONTACTING ELEMENT PRESSED IN.
A fastener may be accidentally discharged.

7. NEVER OPERATE THE TOOL WITH THE WORK CONTACTING ELEMENT REMOVED OR DISABLED.

This device helps reduce the possibility of accidental fastener discharge by preventing the tool from operating until it is completely against the work surface.

NEVER operate the tool if the work contacting element is not working properly.

8. ALWAYS POINT THE TOOL AWAY FROM YOURSELF AND OTHERS WHEN CLEARING JAMS OR REMOVING FASTENERS.

Pull the follower slightly back and push the release lever. Tip the tool nose up slightly and fasteners should slide out of the rear of the magazine. If fasteners are jammed, refer to the appropriate servicing section of this manual.

9. NEVER OPERATE THE TRIMMASTER 18™ FINISH NAILER IF PARTS ARE LOOSE, DAMAGED OR MISSING.

10. DO NOT DRIVE FASTENERS INTO KNOTS OR ON TOP OF OTHER FASTENERS.

A fastener may ricochet and cause serious injury.

11. OPERATE THE TOOL ONLY ON THE WORKPIECE.

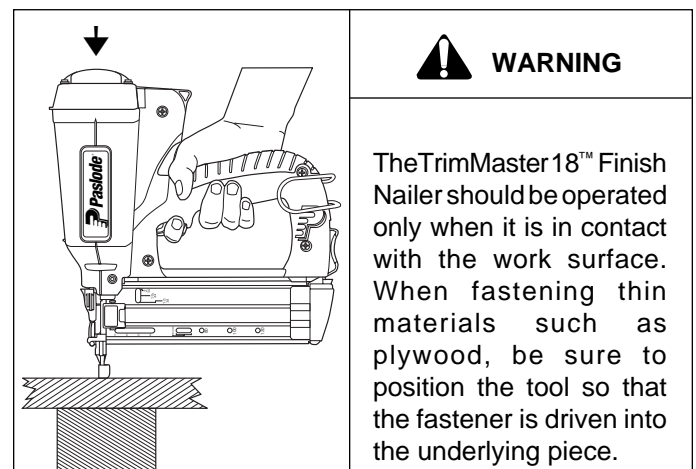



Safety Instructions



12. NEVER DRIVE FASTENERS INTO AREAS WITH CONCEALED HAZARDS.

Always check the area behind the work surface for electrical wiring, gas pipes, water pipes, sewer drains or other potential hazards.

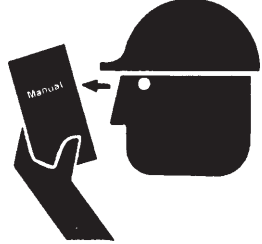

13. ALWAYS MAINTAIN SECURE AND UNOBSTRUCTED FOOTING WHEN ON LADDERS, PLATFORMS OR OTHER HIGH LOCATIONS.

	 WARNING
	<p>Never over-reach, since tool recoil may cause a loss of balance. Always be aware of edges and drop-offs when nailing on rooftops and other high locations. Keep them in full view.</p>

14. ALLOW ONLY QUALIFIED PERSONNEL TO OPERATE THE TRIMMASTER 18™ FINISH NAILER.

	 WARNING
	<p>Only persons who have read and fully understand all tool operation safety and maintenance instructions should be allowed to operate the tool.</p>

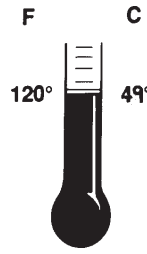
15. PROPERLY STORE FUEL CELL.

	 WARNING
	<p>Always store fuel cells where they will not be exposed to an open flame, sparks or temperatures above 120° F (49° C).</p>



16. ALWAYS STORE THE TOOL WITH THE FUEL CELL AND BATTERY REMOVED.

Store the fuel cell in the case with the TrimMaster 18™ Finish Nailer.

17. KEEP THE TOOL CLEAN.

A clean tool is less likely to jam or malfunction.

18. KEEP YOUR HANDS CLEAR OF THE WORK AREA SURFACE.

	 WARNING
	<p>A fastener may exit at an angle unexpectedly and cause injury.</p>

Battery Disposal:

The Paslode batteries contains cadmium and must be recycled or disposed of properly. It is illegal in some areas to place a nickel-cadmium battery into the trash or solid waste stream. You may contact your local recycling center for information on where to return the spent battery or call 1-800-822-8837 for information on Ni-Cd battery recycling in your area.

Battery and Charging System

Battery and Charging System

The Paslode Cordless tools come with a rechargeable battery and its own charging system. This charging system is the only one that will work with the Paslode batteries (either round or oval). The first step in preparing a new tool for operation is to fully charge the battery. **New batteries are shipped discharged and must be charged prior to first use.** Batteries will take 5 minutes to 2 hours (time will be dependant on the amount of discharge of the battery) to recharge.

Important Charging Notes

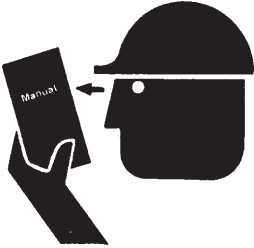
	<p>Warning</p> <p>CHEMICAL/EXPLOSION HAZARD</p> <p>Read ALL instructions before charging or using battery. Failure to follow ALL instructions may result in fire, severe burns, or release of toxic materials.</p>
---	--

Battery Disposal:

The Paslode batteries contain cadmium and must be recycled or disposed of properly. It is illegal in some areas to place a nickel-cadmium battery into the trash or solid waste stream. You may contact your local recycling center for information on where to return the spent battery or call 1-800-822-8837 for information on Ni-Cd battery recycling in your area.

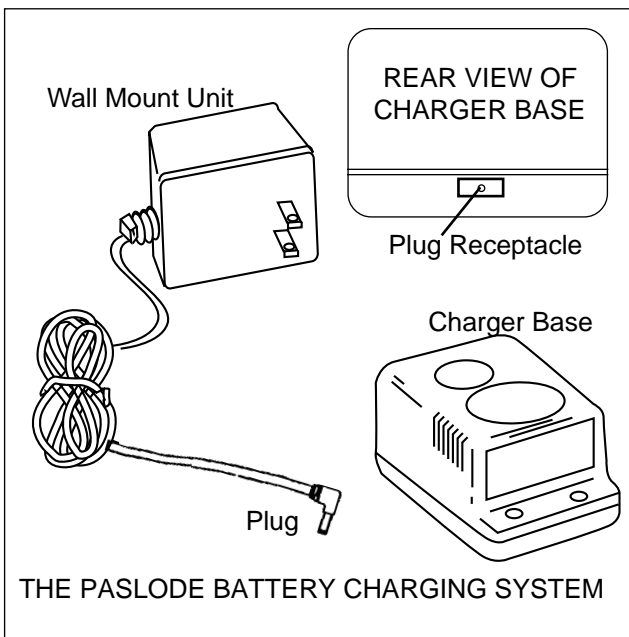

Charging Instructions

1. Remove wall mount unit with the orange label from the tool case and plug into a 120V AC outlet. Set orange charger on a stable surface and insert wall mount unit's plug into plug receptacle on the back of the charger (see picture). A green light indicates power is on and charger circuit is ready.
2. Remove the battery from tool or case and insert terminals down into charger. The red light will come on indicating that the battery is charging and the green light will go out.

NOTE

If battery is completely discharged, the red light and the green light may alternate back and forth for up to 20 minutes. This safety feature slowly recharges the battery until it is ready to accept the full charging current. If the red and green lights continue to alternate after 20 minutes, replace the battery.

3. After charging is complete, the red light will go out and the green light will come on, indicating that the battery is fully charged. The charger will keep the battery at full charge until it is removed.
4. Unplug the wall mount unit from the charger and remove the wall mount unit from the 120V AC outlet.

CHARGING TIMES:

First charge (new battery)	2 hours
Discharged Battery	5 minutes to 2 hours

CHARGING DON'TS:

1. Do not charge battery outdoors or in temperatures below 40°F (5°C).
2. Do not allow metal objects to come in contact with battery terminals.
3. Do not puncture or attempt to open battery case or cells.
4. Do not store battery where it will be subjected to temperatures above 120°F (49°C).
5. Do not incinerate battery.
6. Do not use a defective battery charger, one that over-heats and/or smokes when plugged in.
7. Do not immerse the battery in water.

Paslode Charging System Accessories:

Battery Charger Kit - Part No. 900200
Wall Mount Transformer* - Part No. 900477
Battery Charger Base* - Part No. 900476
Automotive Adapter* - Part No. 900507

* Cannot use with previous (gray in color) charging system components.

Battery and Charging System

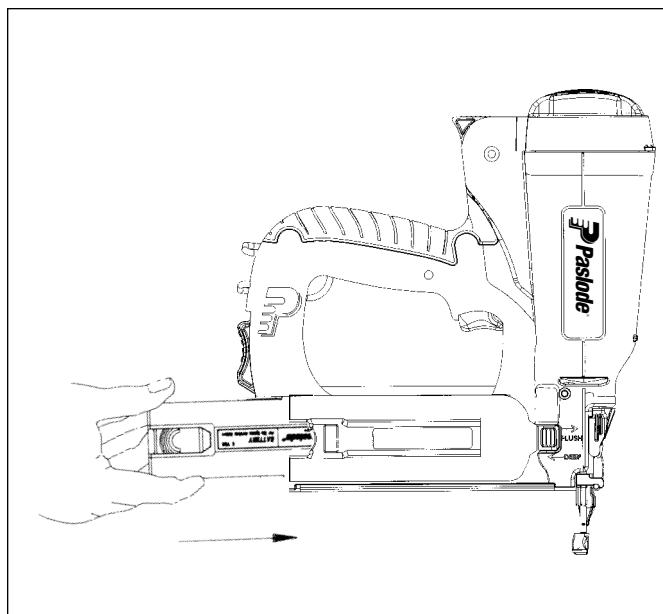

Inserting Battery

1. Load the battery, contacts first, into the TrimMaster 18™ Finish nailer.
2. Push battery fully forward into its locked position.
3. To remove battery, push down on locking tab and slide battery out.

NOTE: If battery is left in tool for an extended period, the battery will discharge completely and will require recharging.

IMPORTANT: Should your battery terminals become corroded and cause poor electrical contact, clean the terminals using a soft cloth.

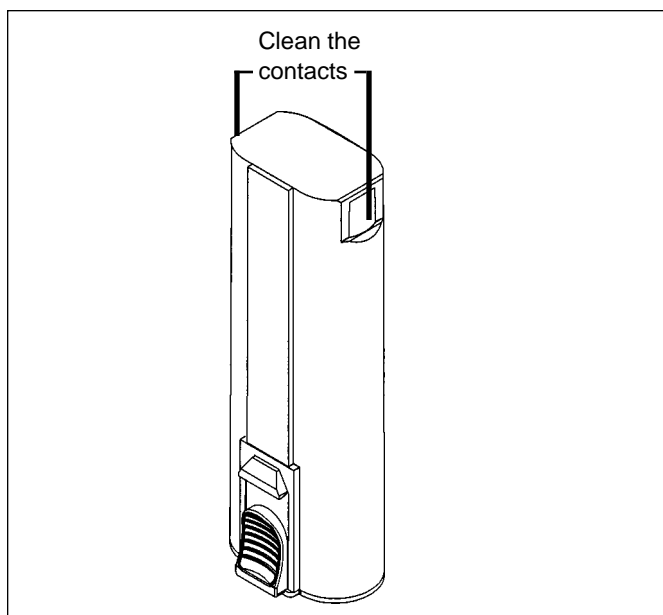

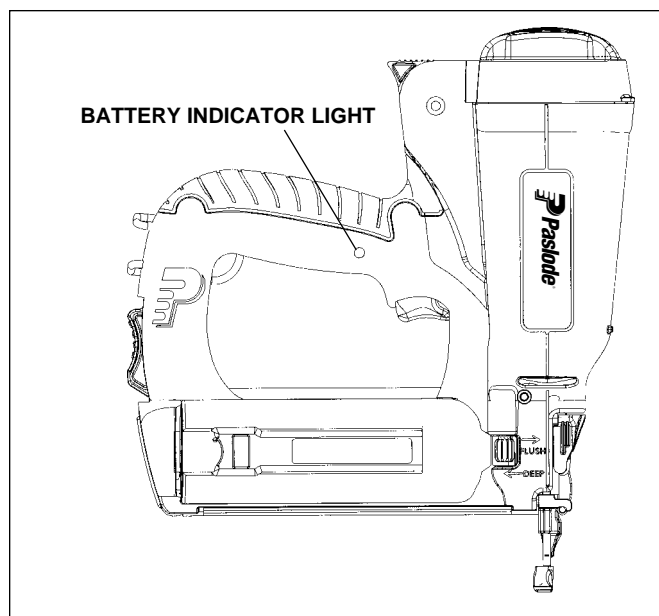

Battery Indicator Light

On the right side of the handle is a small plastic lens. This is the battery indicator light. When you insert a fully-charged battery into the tool, you will see a blinking green light. If the indicator light blinks red, recharge the battery.

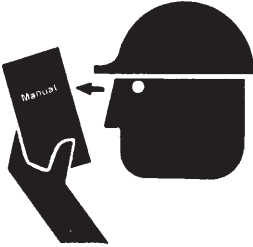

Fuel Cell

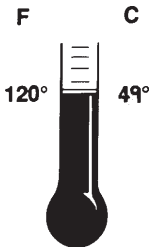
  	<p>⚠ DANGER</p> <p>EXPLOSION/FIRE HAZARD</p> <p>Read ALL safety instructions before using or handling the fuel cell. Failure to follow ALL instructions may result in explosion or fire. This may cause severe personal injuries or property damage.</p> <p>Keep the fuel cell away from heat, sparks and open flame.</p> <p>Exposure to temperatures above 120°F (49°C) may cause the fuel cell to burst, releasing flammable gas.</p>
--	---

<p>⚠ WARNING</p> <p>Sunlight can raise the inside temperature of an unventilated car or van to above 140°F (60°C).</p> <p>Do not puncture or attempt to open the fuel cell; it is non-refillable.</p> <p>Do not incinerate, reclaim or recycle the fuel cell.</p> <p>Do not smoke while installing or operating the metering valve.</p> <p>Do not inhale the spray.</p> <p>Keep out of the reach of children.</p> <p>Store fuel cell(s) in well-ventilated areas only.</p>

There is a second container inside the fuel cell. The inner container holds the fuel. The space between the inner container and the outer cylinder is filled with a gas, called the propellant, which is under pressure.

To eject the fuel, propellant pressure squeezes the inner fuel container, much as you squeeze a tube of toothpaste. This squeezing action ensures that all the fuel is used, and that the Paslode Cordless Finish nailer can operate in any position.

Because of this container-within-a-container design, you might hear the sound of fluid when shaking the fuel cell after all the fuel has been used. This is the propellant, which remains between the containers even after all the fuel has been expelled.

If you expose the empty fuel cell to extreme temperatures, the propellant gas will expand and could cause the container to burst, releasing flammable gases.

Metering Valve

The metering valve contains a fuel metering system to inject the correct amount of fuel into the combustion chamber.

The metering valve with the **yellow face** is the only valve that will operate properly with the TrimMaster 18™ Finish Nailer.

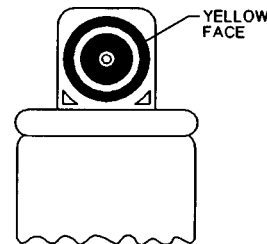

<p>NOTE</p> <ol style="list-style-type: none">1. Do not attempt to reuse the metering valve! Replace with fresh fuel cell/valve, and dispose of spent cell/valve properly.2. When replacing fuel cell also clean the air filter for optimum tool operation.

<p>NOTE: Altitude Restriction</p> <p>Impulse technology is powered by an internal combustion engine and are effected by altitude. The tool may lose power or not cycle consistently at elevations of 4000 feet or greater. When using the tool at elevations of 4000 feet it is recommended to use the blue high altitude fuel metering valve part #219247.</p>

Fuel Cell and Metering Valve

Installing Metering Valve to Fuel Cell Prior to Use

To install the metering valve to a fuel cell:

1. Press downward on the front side of the valve (stem side) until it seats.
2. Press downward on the rear side of the valve until it seats.
3. The valve is now completely seated onto the fuel can and can be inserted into the tool.

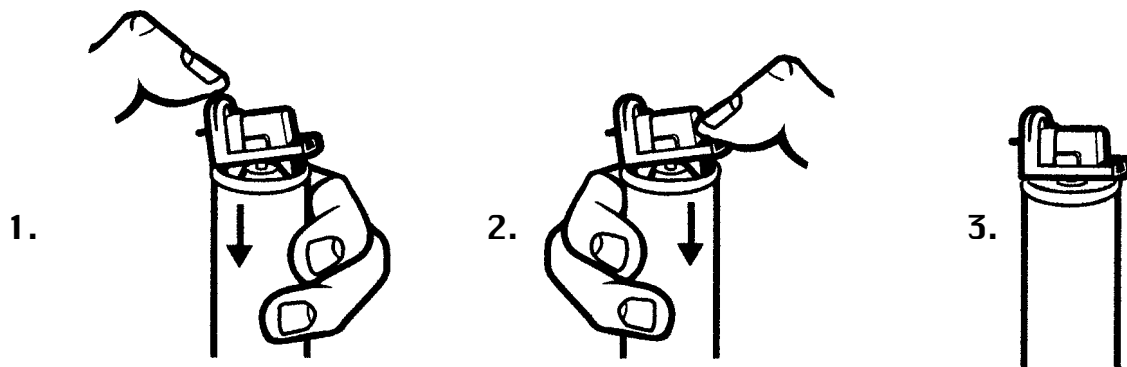

NOTE:

Impulse fuel cell are marked with expiration date on the bottom of the can. For maximum performance use fuel before expiration date.

 **DANGER**

Paslode Fuel is flammable.
Do not smoke when installing the metering valve!

Inserting Fuel Cell

Inserting the metering valve/fuel cell assembly into the TrimMaster 18™ Finish Nailer is very simple. To begin, press up at the bottom of the actuator cover and pivot outward to open. The cover will swing out of the way.

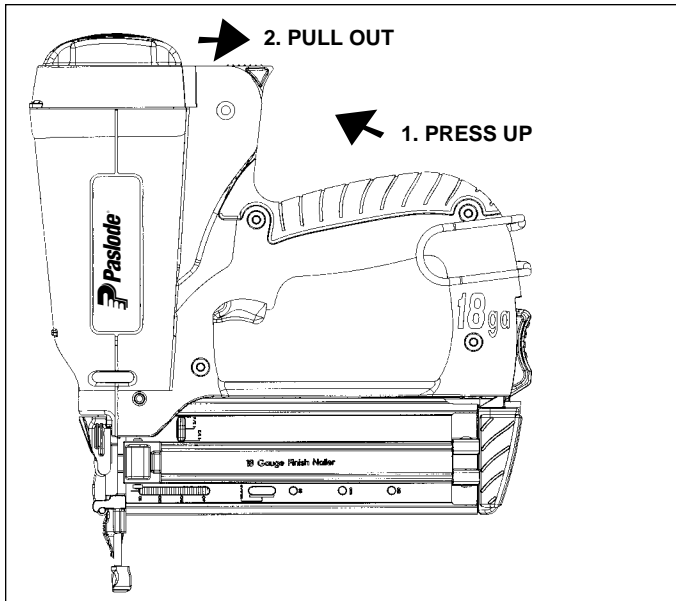

Next, with the metering valve stem pointed toward the front of the tool, insert the metering valve/fuel cell assembly.

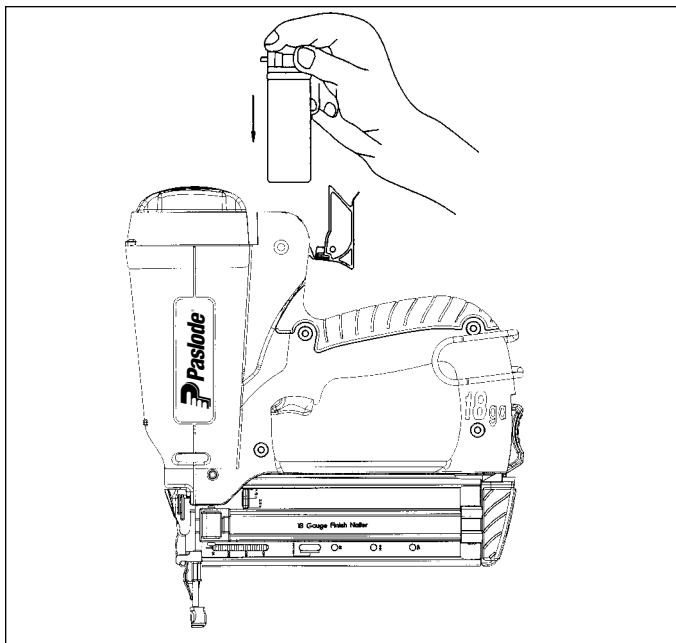

As you slide the metering valve/fuel cell assembly into the TrimMaster 18™ Finish Nailer, you will notice a **yellow** adapter at the top of the cylinder pocket. As shown in the illustration, this adapter is designed to ensure that the metering valve stem is properly aligned with the small hole, or orifice, that leads to the combustion chamber. Insert the metering valve stem into the orifice of the **yellow**-colored adapter.

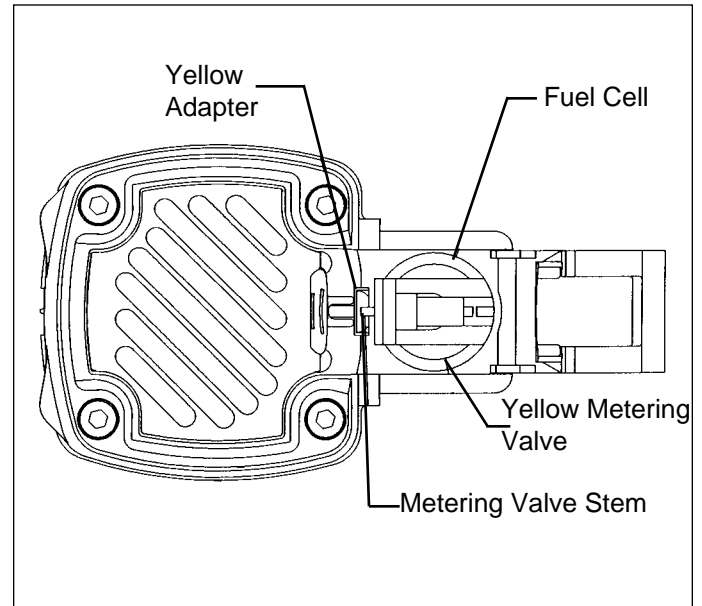

Close the actuator cover to complete the loading of fuel in the TrimMaster 18™ Finish Nailer. Do this by swinging it up and over the fuel valve/cylinder assembly, and pushing down until the actuator cover snaps into position.

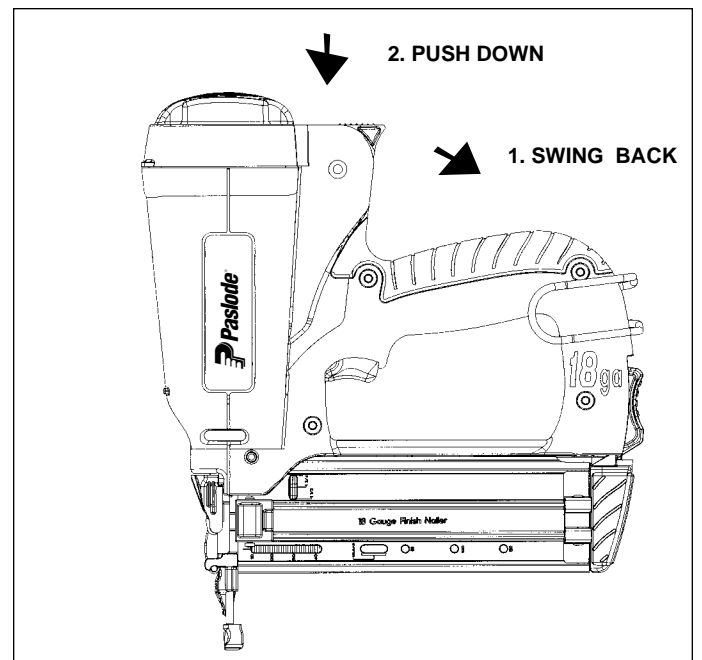

Preparing the TrimMaster 18™ Finish Nailer for Use

Fasteners

The TrimMaster 18™ Finish Nailer drives Paslode® 18 gauge fasteners designed to be used with the tool. The use of fasteners that do not meet Paslode standards could cause tool damage and will void all warranty claims.

Loading Fasteners

Press the release latch with your thumb and pull the rail cover to the full open position.

Place the 18 gauge finish nails into the rail with the points resting in the bottom of the rail.

Slide the rail cover forward to the locked position.

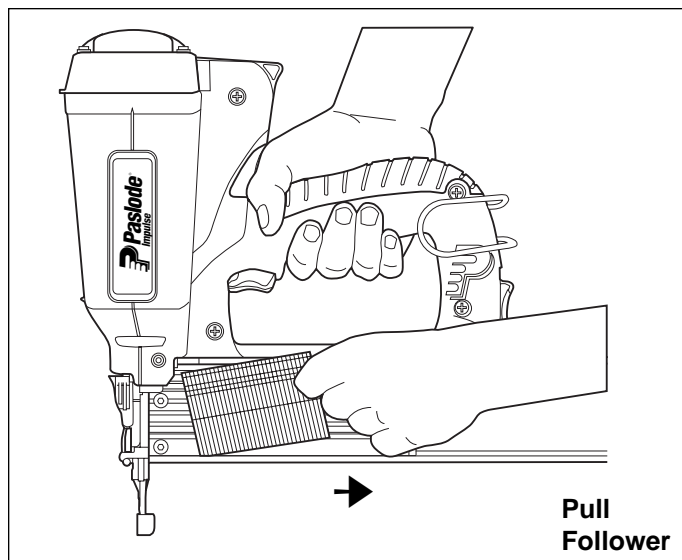

In the illustration above, you will see an indicator arrow on the side of the follower. When the indicator arrow is in the reload area, marked on the side of the magazine, you may insert a new strip of nails.

Impulse® and Outdoor Weather

Use the TrimMaster 18™ Finish Nailer outdoors, in dry weather, when the nailer, fuel cell, and battery are between 20°F (-7°C) and 120°F (49°C).

HOT WEATHER OPERATION

The TrimMaster18™ Finish Nailer requires cooling of the motor assembly to operate properly. The fan normally provides the necessary air flow to permit continuous operation. Whenever the TrimMaster 18™ Finish Nailer is idle for extended periods, keep the fuel and tool out of direct sunlight and in surroundings where temperatures will not exceed 120°F (49°C). After extended periods of continuous use, it may be necessary to cool the Impulse motor by setting tool aside for 10-15 minutes or until the tool operates normally. An overheated tool may not drive nails completely or may operate erratically.

COLD WEATHER OPERATION

Fuel cells at cold temperatures lose the required propellant pressure. Bring the tool, fuel cell, and battery above 20° F (-7° C) by placing the tool in a heated building or vehicle. Never expose the tool, fuel cell or battery to flame

CAUTION

The TrimMaster18™ Finish Nailer should not be used in the rain or where excessive moisture is present. The use of the Impulse Technology under these conditions may result in damage to tool components and cause the tool to malfunction.

TrimMaster 18™ Finish Nailer Operation

Operation:

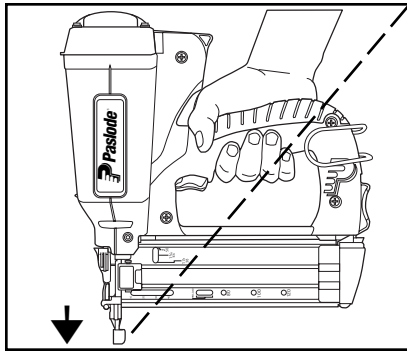

PRESS WORK – CONTACTING ELEMENT AGAINST THE WORK SURFACE.

Fan motor starts, fuel is injected into combustion chamber and mixed with air by the fan.

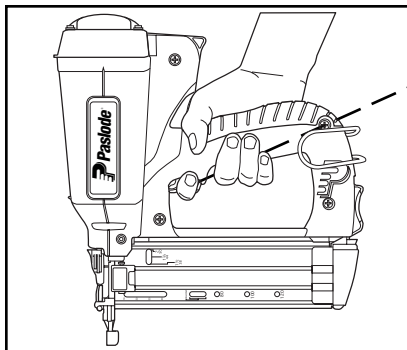

SQUEEZE TRIGGER

Spark plug ignites the fuel/air mixture driving the piston assembly down on the fastener.

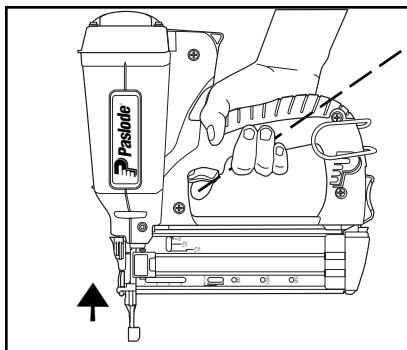

RELEASE TRIGGER - LIFT TOOL

Combustion chamber opens. Fan exhausts hot gases and cools internal components.

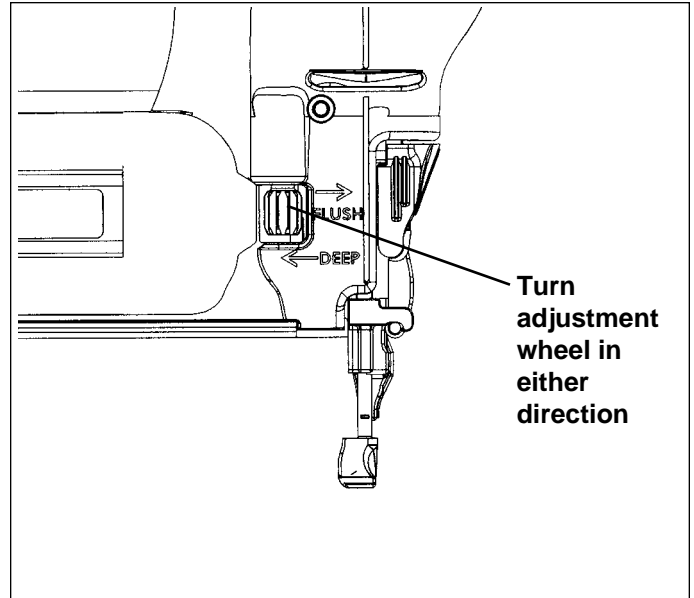

Depth of Drive Adjustment

Remove the battery before adjusting the depth of drive.

The depth of drive adjustment is done by turning the adjustment wheel as shown by the arrows on the side of the tool.



DANGER

The work contacting element and nose will become hot after prolonged or rapid use. If it becomes necessary to adjust the work contacting element, avoid touching with bare hands.



CAUTION

This tool must be operated in a well ventilated environment, because the tool exhausts carbon monoxide similar to a chainsaw or lawn mower. Exposure to carbon monoxide may cause dizziness, nausea or unconsciousness.

NOTE: Altitude Restriction

Impulse® technology is powered by an internal combustion engine and are effected by altitude. The tool may lose power or not cycle consistently at elevations of 4000 feet or greater. When using the tool at elevations of 4000 feet it is recommended to use the **blue** high altitude fuel metering valve part #219247.

Fasteners and Applications

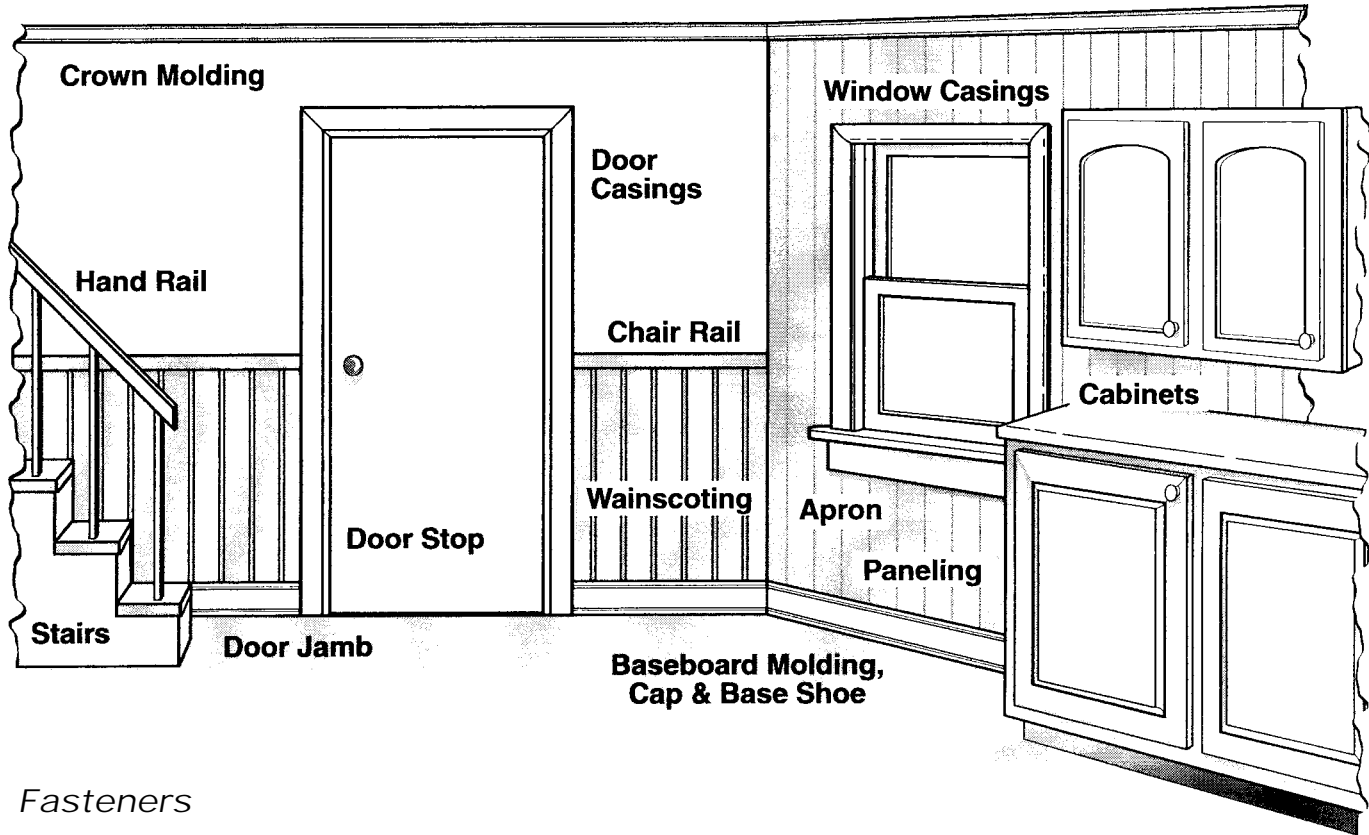

Applications

The TrimMaster 18™ Finish Nailer is suited for a variety of applications. These include securing door and window casings; attaching baseboards where walls meet floors; attaching moldings where walls meet ceilings; securing paneling; securing chair rails, picture molding and other decorative trim.

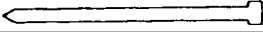
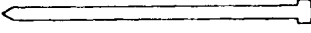
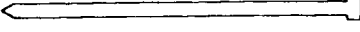
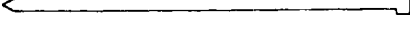

Fasteners

The TrimMaster 18™ Finish Nailer drives Paslode 18 Gauge finish nails. Fasteners are collated into strips of 50 for easy loading. Paslode fasteners are designed to be used in Paslode tools, use of other fasteners may cause damage to the tool or injury to the tool operator.

THE IMPULSE 18 Ga. BRAD NAILER DRIVES THESE NAILS	Fuel Fastener Pack	Fastener Pack	Length	Applications
	650267	650211	5/8"	Cabinetry, Cove Molding, Shoe & Base Molding, Underneath Stair Tread, Mitered Corners, Lattice Strip Molding, Crown Molding Outside Corners, Book Cases
	650268	650212	1"	Cabinetry, Cove Molding, Shoe & Base Molding, Underneath Stair Tread, Mitered Corners, Lattice Strip Molding, Crown Molding, Book Cases
	650269	650213	1-1/4"	Cabinetry, Shoe & Base Molding, Scribe Molding, Crown Molding, Book Cases
	650270	650214	1-1/2"	Cabinetry, Shoe & Base Molding, Risers, Stairs, Knee Wall, Panel Installation, Wainscoting, Chair Rail, Window Casings, Door Casings, Book Cases
	650271	650215	2"	Cabinetry, Shoe & Base Molding, Spindles, Risers, Stairs, Knee Wall, Panel Installation, Wainscoting, Panel, Chair Rail, Window Casings, Door Casings, Book Cases

Restrict Field Service to the Following

- CHECKING THE ENERGY LEVEL OF THE BATTERY
- RECHARGING THE BATTERY
- CHECKING THE FUEL CELL AND METERING VALVE
- REPLACING THE FUEL CELL
- CLEANING/REPLACING THE AIR FILTER
- CLEARING A JAM
- CLEANING THE TOOL (See cleaning manual)

Attempts to go beyond these procedures could result in serious personal injury or damage to the TrimMaster 18™ Finish Nailer and voiding the warranty.

There are certain problems you may encounter when you are using the TrimMaster 18™ Finish Nailer that you will be able to correct on the work site. The following field service procedures are the only service procedures you should attempt. Anything else that may appear wrong with the TrimMaster 18™ Finish Nailer should only be diagnosed and repaired by a fully trained service technician. If you have any reason to believe that your problem is beyond the service procedures in this manual, contact your Paslode® representative immediately.



DANGER

Never attempt any maintenance of a Paslode Cordless tool without first removing the fuel cell and battery. Maintenance should be started only after the tool is **completely** inoperative.

Battery Check

Periodically check on the battery indicator light (the light in the handle) of the TrimMaster 18™ Finish Nailer. When encountering a problem, the first step should always be to make sure the battery has enough charge to operate the tool.

When the work contacting element is depressed on work piece, the fan motor will turn on and the blinking green indicator light will turn solid green. If the indicator light blinks red or glows red, recharge the battery.

Fuel Cell Check

If the Impulse® 18 Ga. Brad Nailer's fan operates and the indicator light is green, but the tool will not cycle or does not drive fasteners completely, check the fuel cell. With the fuel cell out of the tool, check to see if the cell still contains fuel and that the metering valve is working. To determine if there is any fuel left in the fuel cell, hold in the upright position and simply place the metering stem against a solid object, and gently push about three or four times. A small amount of fuel should be released each time.



DANGER

Wear safety glasses when performing this test. Never perform this test near an open flame or sparks, while smoking, or where the fuel may get into your eyes.

If fuel is not released with each operation of the metering valve, this indicates that there is no more fuel left in the cylinder and it must be replaced. Dispose of the empty fuel cell properly. (see page 16.)

Clearing a Jam

An occasional problem you may encounter is a jammed fastener. Because of the unique design of the TrimMaster 18™ Finish Nailer, clearing a jammed fastener is easy:

1. Remove the battery.
2. Pull the latch, releasing front guide. Pivot front guide forward.
3. Clear jam, and push driver blade back up to its normal position.
4. Close front guide and latch it. Check that work contacting element moves freely.

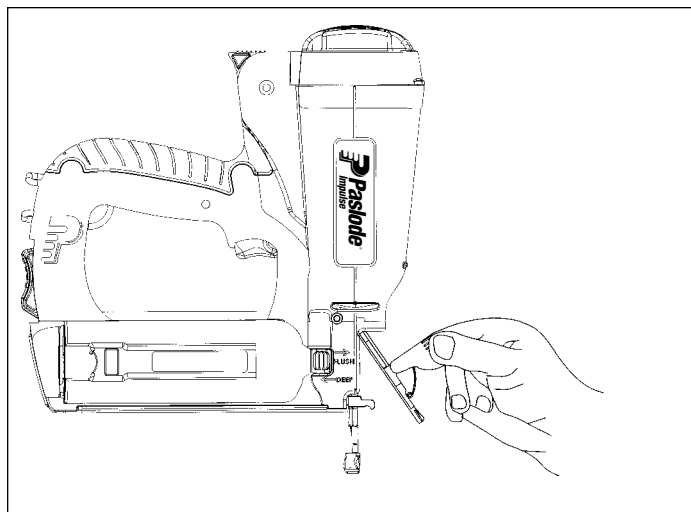

Air Filter

Open the cover by pressing slightly above the adapter and pivoting the cover open. The air filter simply lifts out.

Tap the filter GENTLY to remove any dust. Check and clean the air filter every two days. Soap and water restores the filter to a "like new" condition.

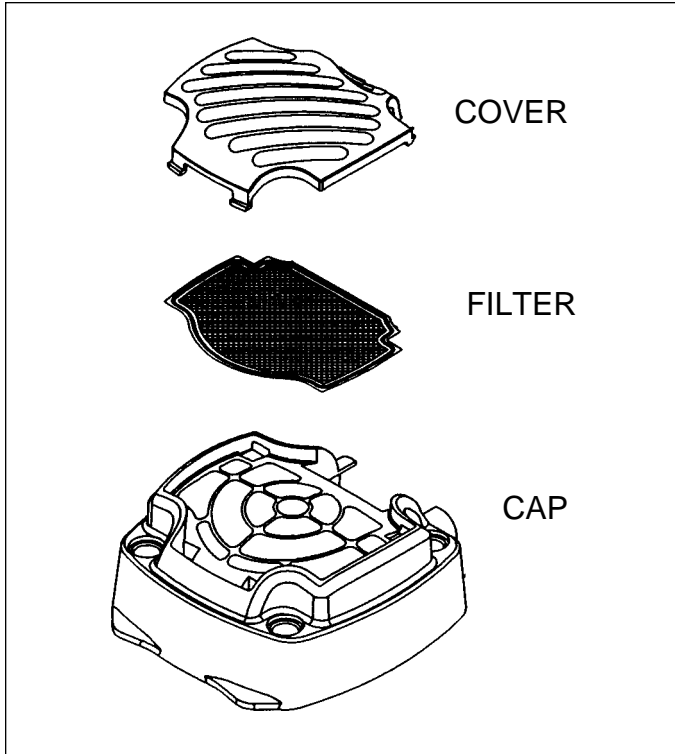

End-of-Workday Routine

These simple steps are based on maintaining the safety and operational efficiency of the Impulse® 18 Ga. Brad Nailer.

Before you leave the work site:

1. Remove battery and store in tool case. Always use the TrimMaster 18™ Finish Nailer case for transporting and storing the tool.
2. Dispose of all empty fuel cells. Remember to dispose of these cells where they will not be crushed, punctured, burned or found by children.

When you get home:

1. Place the battery in its charger if it needs charging as indicated by the red charge light on the handle.
2. Wipe your TrimMaster 18™ Finish Nailer with a clean, soft cloth.
3. Remove and clean the filter every two days.
4. Check work contacting element to ensure it is operating freely.

Paslode Cordless Tool Accessories

A variety of accessories are available for the Impulse® 18 Ga. Brad Nailer:

No-Mar Replacement Tip -Hard Tip Part No. 901048

No-Mar Replacement Tip -Soft Tip Part No. 901067

Battery - Part No. 404717

Extra battery allows use of one battery while spare battery is being charged.

Tinted Safety Glasses - Part No. 402512:

Cuts glare while affording eye protection.

Clear Safety Glasses - Part No. 402510

Impulse® Oil - Part No. 401482

Battery Charger Kit - Part No. 900200

Automotive Adapter - Part No. 900507

TrimMaster 18™ Finish Nailer Case - Part No. 901058

High Altitude Valve Kit - Part No. 219247

Contact your Paslode® representative for additional information.

Tools

A 9/64 Hex Wrench (Part No. 900736) is provided with each TrimMaster 18™ Finish Nailer .

Preparing Tool for Operation - Battery/Charger Problems

SYMPTOM	POSSIBLE PROBLEMS	SERVICE
Battery does not appear to accept charge when battery is plugged into the charger.	Inoperative indicator lights on charger, or defective charger.	Try battery in tool after a full charge cycle. If tools indicator light is red, charger not working properly. Replace charger, or monitor charging time to ensure battery has adequate time for recharging. It is normal for battery to feel warm after properly charging.
	Battery damaged or cycle life exhausted.	Replace battery.
Charger gets hot, makes excessively loud noise, or smokes during charging cycle. Charger cord or wall plug gets hot.	Damaged charger.	Discontinue use immediately and unplug from power source. Replace charger and tag or dispose of charger to prevent accidental re-use or connection to power source.

Normal Stage of Operation

SYMPTOM	POSSIBLE PROBLEMS	SERVICE
Fan does not run - tool indicator light is blinking red or solid red.	Battery is not charged.	Charge battery.
	Battery terminals are oily, dirty, or corroded.	Clean battery terminals with soft cloth.
Fan does not run, or runs slower than normal - tool indicator light is solid red.	Battery is discharged.	Charge battery.
Work-contacting element does not depress fully - tool does not operate.	Work-contacting element is bent, or build-up of debris in track restricts operation.	Remove and inspect lower probe. Clean the track. Repair or replace lower probe as required.
	Lockout feature is engaged.	Add strip of nails.
Tool will not cycle - fan runs, indicator light is solid green.	Fuel Cell empty.	Replace fuel cell.
	Spark wire out of spark plug.	Remove cap and check spark lead, insert in spark plug and replace cover.
	Spark plug is dirty.	Clean tool cylinder head.
	No spark is generated.	Return tool to authorized Paslode® dealer for service.

Troubleshooting

Normal Stage of Operation

SYMPTOM	POSSIBLE PROBLEMS	SERVICE
Tool operates properly, but fasteners do not drive fully.	Work-contacting element requires adjustment.	Adjust work contacting element.
	Fuel cell is low.	Check fuel cell and replace as required.
	There may be loss of seal in combustion chamber.	Press work contacting element against workpiece for one minute. Pull trigger. If fastener does not drive, there is a leak that requires service.
Tool operates properly, but fasteners are sometimes over-driven, and sometimes under-driven.	Work-contacting element is not adjusted properly for the type of material being fastened.	Adjust work-contacting element. Readjust as required when material density or thickness of material being fastened changes.
Tool operates, but no fastener is driven.	Wrong fasteners being used.	Use only fasteners meeting Paslode® specifications. Check Fasteners and Applications section for fastener types and sizes recommended for use in Impulse tool.
	Follower not properly engaged behind fastener strip.	Position follower behind fastener strip and engage strip.
	Jammed fastener.	Clear jam.
Tool operates erratically or appears to be losing power - tool indicator light is green.	Fuel cell is low.	Check fuel cell.
	Spark plug wire is loose.	Check spark plug wire.
	Air filter is dirty, causing tool to overheat.	Remove air filter and clean. Use soap and water to remove stubborn debris.
	Tool is dirty.	Clean tool.
Tool operated and drove fasteners, but driver blade did not return to up position.	Built-up dirt and debris on driver blade or in nose bore.	Clean driver blade and nose bore with degreaser cleaner.
	Tool is dirty.	Clean tool.
Combustion chamber does not drop after tool cycles.	Work-contacting element is bent, or is dirty.	Clean track or replace work-contacting element.

If nailer will not operate after following the above service directions, return the tool to an authorized Paslode® representative for service.

For the nearest Paslode® representative call 1-800-682-3428.

For Technical support call 1-800-222-6990.



An Illinois Tool Works Company
 888 Forest Edge Drive
 Vernon Hills, Illinois 60061
www.paslode.com

Model Number	PART NO.
IM200 F18	901000

PASLODE MODEL NUMBER DESIGNATION

The model number of each Paslode tool contains information about the tool and the fasteners that are used with it. The following example illustrates the information contained in this tool model number.

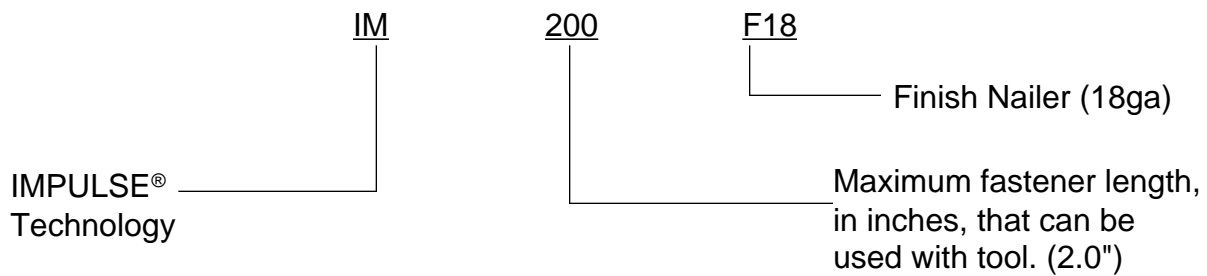

Free Manuals Download Website

<http://myh66.com>

<http://usermanuals.us>

<http://www.somanuals.com>

<http://www.4manuals.cc>

<http://www.manual-lib.com>

<http://www.404manual.com>

<http://www.luxmanual.com>

<http://aubethermostatmanual.com>

Golf course search by state

<http://golfingnear.com>

Email search by domain

<http://emailbydomain.com>

Auto manuals search

<http://auto.somanuals.com>

TV manuals search

<http://tv.somanuals.com>