

HITACHI

INSTRUCTION MANUAL AND SAFETY INSTRUCTIONS FOR AIR COMPRESSOR

MODEL **EC 10SB (SL)** **EC 12**

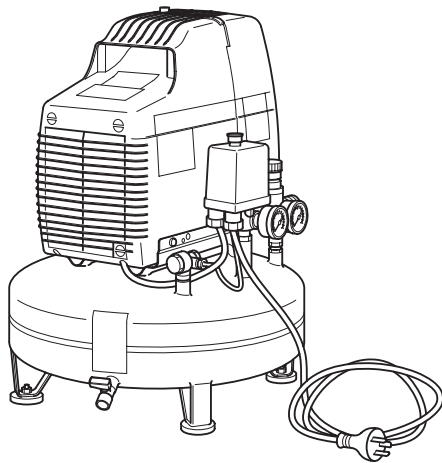

EC 10SB(SL)

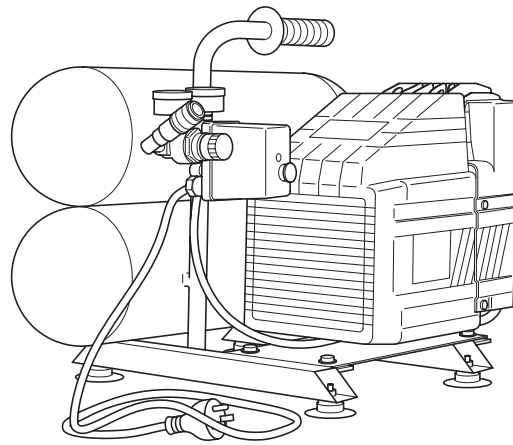

EC 12

⚠ WARNING

Improper and unsafe use of this compressor can result in death or serious bodily injury!
This manual contains important information about product safety.
Please read and understand this manual before operating the compressor.
Please keep this manual available for others before they use the compressor.

— CONTENTS —

	Page		Page
IMPORTANT INFORMATION	2	OPERATION AND MAINTENANCE	
MEANINGS OF SIGNAL WORDS	2	NAME OF PARTS	7
SAFETY		SPECIFICATIONS	8
IMPORTANT SAFETY INSTRUCTIONS		ACCESSORY	8
FOR USE OF THE COMPRESSOR	3	APPLICATIONS	8
REPLACEMENT PARTS	5	PRIOR TO OPERATION	8
GROUNDING INSTRUCTIONS	5	TRANSPORT	9
EXTENSION CORD	6	OPERATION	9
		MAINTENANCE	10
		SERVICE AND REPAIRS	11
		PARTS LIST	12

IMPORTANT INFORMATION

Read and understand all of the operating instructions, safety precautions and warnings in the Instruction Manual before operating or maintaining this compressor.

Most accidents that result from compressor operation and maintenance are caused by the failure to observe basic safety rules or precautions. An accident can often be avoided by recognizing a potentially hazardous situation before it occurs, and by observing appropriate safety procedures.

Basic safety precautions are outlined in the "SAFETY" section of this Instruction Manual and in the sections which contain the operation and maintenance instructions.

Hazards that must be avoided to prevent bodily injury or machine damage are identified by WARNINGS on the compressor and in this Instruction Manual.

Never use this compressor in a manner that has not been specifically recommended by HITACHI, unless you first confirm that the planned use will be safe for you and others.

MEANINGS OF SIGNAL WORDS

WARNING indicates a potentially hazardous situations which, if ignored, could result in death or serious injury.

CAUTION indicates a potentially hazardous situations which, if not avoided, may result in minor or moderate injury, or may cause machine damage.

NOTE emphasizes essential information.

SAFETY

IMPORTANT SAFETY INSTRUCTIONS FOR USE OF THE COMPRESSOR

⚠ WARNING: Death or serious bodily injury could result from improper or unsafe use of compressor.
To avoid these risks, follow these basic safety instructions:

READ ALL INSTRUCTIONS

- 1. NEVER TOUCH MOVING PARTS.**
Never place your hands, fingers or other body parts near the compressor's moving parts.
Never insert your fingers or other objects into the housing's ventilator. Such an action invites the danger of injuries or electric shocks.
- 2. NEVER OPERATE WITHOUT ALL GUARDS IN PLACE.**
Never operate this compressor without all guards or safety features in place and in proper working order. If maintenance or servicing requires the removal of a guard or safety features, be sure to replace the guard or safety features before resuming operation of the compressor.
- 3. ALWAYS WEAR PROTECTION.**
Risk of injury. Always wear ANSI Z87.1 safety glasses or equivalent eye protection. Compressed air must never be aimed at anyone or any part of the body. Use ear protection as air flow noise is loud when draining.
- 4. PROTECT YOURSELF AGAINST ELECTRIC SHOCK.**
Prevent body contact with grounded surfaces such as pipes, radiators, ranges and refrigeration enclosures. This compressor must be properly grounded. Never operate the compressor in damp or wet locations. To reduce risk of electric shock, do not remove cover.
- 5. DISCONNECT THE COMPRESSOR.**
Always disconnect the compressor from the power source and remove the compressed air from the air tank before servicing, inspecting, maintaining, cleaning, replacing or checking any parts.
- 6. AVOID UNINTENTIONAL STARTING.**
Do not carry the compressor while it is connected to its power source or when the air tank is filled with compressed air. Be sure the knob of the pressure switch in the "OFF" position before connecting the compressor to its power source.
- 7. STORE COMPRESSOR PROPERLY.**
When not in use, the compressor should be stored in indoor dry place. Keep out of reach of children. Lock-out the storage area.
- 8. KEEP WORK AREA CLEAN.**
Cluttered areas invite injuries. Clear all work areas of unnecessary tools, debris, furniture, etc.
- 9. CONSIDER WORK AREA ENVIRONMENT.**
Risk of electric shock. Don't expose compressor to rain. Don't use compressor in damp or wet locations. Keep work area well lit and well ventilated. Risk of fire or explosion. Do not carry and operate the compressor or any other electrical device near the spray area. Don't use compressor in the presence of flammable liquids or gases. Compressor produces sparks during operation. Never use compressor in sites containing lacquer, paint, benzene, thinner, gasoline, gases, adhesive agents, and other materials which are combustible or explosive.
- 10. KEEP CHILDREN AWAY.**
Do not let visitors contact compressor extension cord. All visitors should be kept safely away from work area.
- 11. DRESS PROPERLY.**
Do not wear loose clothing or jewelry. They can be caught in moving parts. Wear protective hair covering to contain long hair.
- 12. DON'T ABUSE CORD.**
Never yank it to disconnect from receptacle. Keep cord from heat, oil and sharp edges.
- 13. MAINTAIN COMPRESSOR WITH CARE.**
Follow instructions for lubricating. Inspect cords periodically and if damaged, have repaired by authorized service center. Inspect extension cords periodically and replace if damaged.
- 14. OUTDOOR USE EXTENSION CORDS.**
When compressor is used outdoors, use only extension cords intended for use outdoors and so marked.
- 15. STAY ALERT.**
Watch what you are doing. Use common sense. Do not operate compressor when you are tired. Compressor should never be used by you if you are under the influence of alcohol, drugs or medication that makes you drowsy.

16. CHECK DAMAGED PARTS AND AIR LEAK.

Before further use of the compressor, a guard or other part is damaged should be carefully checked to determine that it will operate properly and perform its intended function. Check for alignment of moving parts, binding of moving parts, breakage of parts, mounting, air leak, and any other conditions that may affect its operation.

A guard or other part that is damaged should be properly repaired or replaced by an authorized service center unless otherwise indicated elsewhere in this Instruction Manual.

Have defective pressure switches replaced by authorized service center.

Do not use compressor if switch does not move it on and off.

17. NEVER USE COMPRESSOR FOR APPLICATIONS OTHER THAN THOSE SPECIFIED.

Never use compressor for applications other than those specified in the Instruction Manual.

18. HANDLE COMPRESSOR CORRECTLY.

Operate the compressor according to the instructions provided herein. Never allow the compressor to be operated by children, individuals unfamiliar with its operation or unauthorized personnel.

19. KEEP ALL SCREWS, BOLTS AND COVERS TIGHTLY IN PLACE.

Keep all screws, bolts, and covers tightly mounted. Check their conditions periodically.

20. KEEP MOTOR AIR VENT CLEAN.

The motor air vent must be kept clean so that air can freely flow at all times. Check for dust build-up frequently.

21. OPERATE COMPRESSOR AT THE RATED VOLTAGE.

Operate the compressor at voltages specified on their nameplates.

If using the compressor at a higher voltage than the rated voltage, it will result in abnormally fast motor revolution and may damage the unit and burn out the motor.

22. NEVER USE A COMPRESSOR WHICH IS DEFECTIVE OR OPERATING ABNORMALLY.

If the compressor appears to be operating unusually, making strange noises or vibration, or otherwise appears defective, stop using it immediately and arrange for repairs by a Hitachi authorized service center.

23. DO NOT WIPE PLASTIC PARTS WITH SOLVENT.

Solvents such as gasoline, thinner, benzene, carbon tetrachloride, and alcohol may damage and crack plastic parts. Do not wipe them with such solvents. Wipe plastic parts with a soft cloth lightly dampened with soapy water and dry thoroughly.

24. USE ONLY GENUINE HITACHI REPLACEMENT PARTS.

Replacement parts not manufactured by Hitachi may void your warranty and can lead to malfunction and resulting injuries. Genuine Hitachi parts are available from your dealer.

25. DO NOT MODIFY THE COMPRESSOR.

Do not modify the compressor. Always contact the Hitachi authorized service center any repairs. Unauthorized modification may not only impair the compressor performance but may also result in accident or injury to repair personnel who do not have the required knowledge and technical expertise to perform the repair operations correctly.

26. PUSH THE KNOB OF THE PRESSURE SWITCH TO OFF WHEN THE COMPRESSOR IS NOT USED.

When the compressor is not used, push the knob of the pressure switch OFF, disconnect it from the power source and open the drain cock to discharge the compressed air from the air tank.

27. NEVER TOUCH HOT SURFACE.

To reduce the risk of burns, do not touch tubes, heads, cylinder and motors.

28. DO NOT DIRECT AIR STREAM AT BODY.

Risk of injury, do not direct air stream at persons or animals. Never use compressed air for breathing or respirators.

29. DRAIN TANK.

Risk of bursting. Water will condense in the air tank. If not drained, water will corrode and weaken the air tank causing a risk of air tank rupture. Drain tank daily or after 4 hours of use. To drain tank open valve slowly and tilt compressor to empty accumulated water.

30. DO NOT STOP COMPRESSOR BY PULLING OUT THE PLUG.

This could result in damage to the unit. Use the "ON/OFF" knob of pressure switch.

31. MAKE SURE THE COMPRESSOR OUTLET PRESSURE IS SET LOWER THAN THE MAXIMUM OPERATING PRESSURE OF THE TOOL.

Too much air pressure causes a hazardous risk of bursting. Check the manufacturer's maximum pressure rating for air tools and accessories. The regulator outlet pressure must never exceed the maximum pressure rating.

32. DO NOT ATTEMPT TO OPERATE THIS COMPRESSOR WITHOUT FIRST ADDING OIL TO THE CRANKCASE. (only for EC12)

The compressor is shipped without oil in the crankcase. Serious damage can result from even limited operation unless filled with oil and broken in correctly. Make sure to closely follow initial prior to operation procedures.

33. THE SAFETY VALVE MUST WORK PROPERLY.

Risk of bursting. Before starting the compressor pull the ring on the safety valve to make sure the valve moves freely. If the safety valve does not work properly, over-pressurization may occur, causing air tank rupture or an explosion.

REPLACEMENT PARTS

When servicing use only identical replacement parts. Repairs should be conducted only by a Hitachi authorized service center.

GROUNDING INSTRUCTIONS

This compressor should be grounded while in use to protect the operator from electric shock. The compressor is equipped with a three-conductor cord and three-prong grounding type plug to fit the proper grounding type receptacle. The green (or green and yellow) conductor in the cord is the grounding wire. Never connect the green (or green and yellow) wire to a live terminal.

We recommend that you never disassemble the compressor or try to do any rewiring in the electrical system. Any repairs should be performed only by HITACHI Service Centers or other qualified service organizations. Should you be determined to make a repair yourself, remember that the green colored wire is the "grounding" wire. Never connect this green wire to a "live" terminal. If you replace the plug on the power cord, be sure to connect the green wire only to the grounding (longest) prong on a 3-prong plug.

If in doubt, call a qualified electrician and have the receptacle checked for ground.

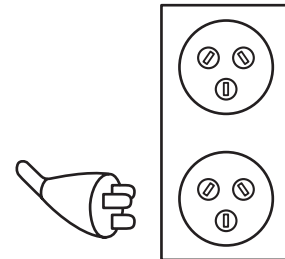

EXTENSION CORD

Use only three-wire extension cords that have three-prong grounding-type plugs and three-pole receptacles that accept the compressor's plug. Replace or repair damaged cord.

Make sure your extension cord is in good condition. When using an extension cord, be sure to use one heavy enough to carry the current your product will draw. An undersized cord will cause a drop in line voltage resulting in loss of power and overheating. Table shows the correct size to use depending on cord length and name plate ampere rating. If in doubt, use the next heavier gage. The smaller the gage number, the heavier the cord.

MINIMUM GAGE FOR CORD SETS

		Total Length of Cord in Feet (Meter)			
		0 – 25 (0 – 7.6)	26 – 50 (7.9 – 15.2)	51 – 100 (15.5 – 30.5)	101 – 150 (30.8 – 45.7)
Ampere Rating More Than		Wire guage size AWG(mm ²)			
Not More Than					
0 – 6		18 (1.0)	16 (1.5)	16 (1.5)	14 (2.0)
6 – 10		18 (1.0)	16 (1.5)	14 (2.0)	12 (3.5)
10 – 12		16 (1.5)	16 (1.5)	14 (2.0)	12 (3.5)
12 – 16		14 (2.0)	12 (3.5)	Not Recommended	

⚠ WARNING: Avoid electrical shock hazard. Never use this compressor with a damaged or frayed electrical cord or extension cord. Inspect all electrical cords regularly. Never use in or near water or in any environment where electric shock is possible.

**SAVE THESE INSTRUCTIONS
AND
MAKE THEM AVAILABLE TO
OTHER USERS OF THIS TOOL!**

OPERATION AND MAINTENANCE

NOTE:

The information contained in this Instruction Manual is designed to assist you in the safe operation and maintenance of the compressor.

Some illustrations in this Instruction Manual may show details or attachments that differ from those on your own compressor.

NAME OF PARTS

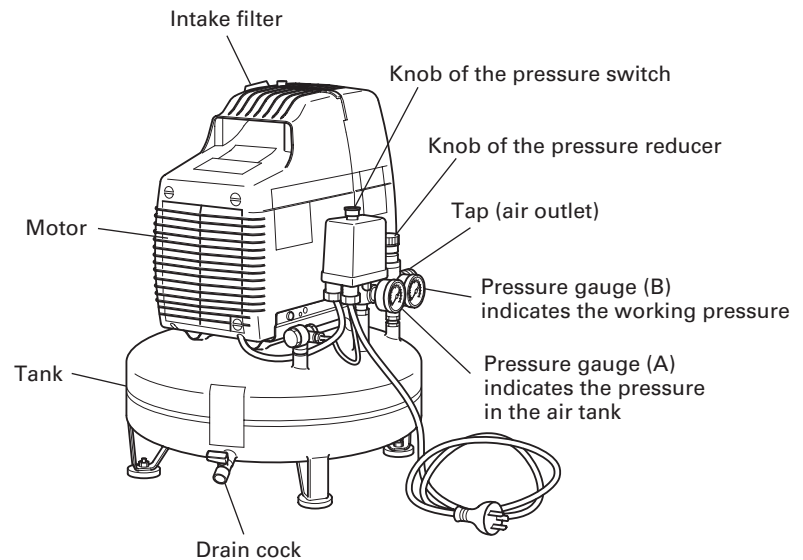

EC 10SB(SL)

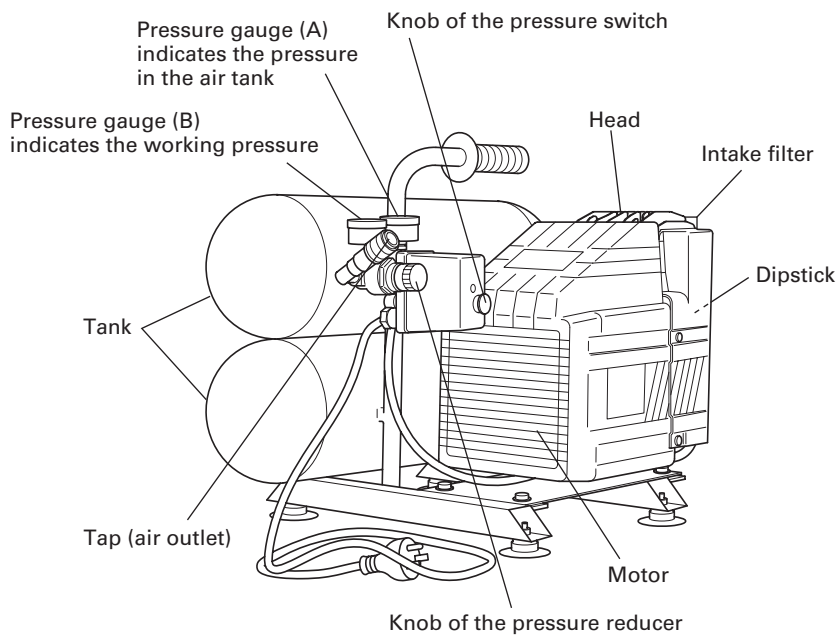

EC 12

Fig. 1

SPECIFICATIONS

Model	EC10SB(SL)	EC12	
Motor	Single-Phase, Induction Motor		
Power Source	Single-Phase, 240V AC 50Hz		
Input	2 HP (1.5 KW)		
Current	9.5 A		
Tank Capacity	4 gal. (15.1 ltr)		
Maximum Pressure	116 PSI (8 bar)	125 PSI (8.6 bar)	
Free Air Delivery	at 40 PSI (2.8 bar)	6.3 CFM (177 ltr/min)	5.9 CFM (168 ltr/min)
	at 90 PSI (6.2 bar)	5.1 CFM (144 ltr/min)	4.8 CFM (136 ltr/min)
	at 100 PSI (6.9 bar)	4.6 CFM (130 ltr/min)	4.6 CFM (130 ltr/min)
Lubrication	Oil-less	Oil	

ACCESSORY

⚠ WARNING: Accessory other than these shown below can lead to malfunction and resulting injuries.

STANDARD ACCESSORY

⟨ EC 10SB(SL) ⟩

NO ACCESSORIES

⟨ EC 12 ⟩

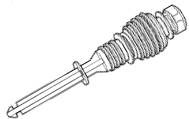

Dipstick ----- 1

APPLICATIONS

○ Air source of the pneumatic nailer and stapler.

⚠ WARNING: Never use compressor for applications other than compressor for pneumatic nailer and stapler.

PRIOR TO OPERATION

- Power source**
Ensure that the power source to be utilized conforms to the power source requirements specified on the product nameplate.
- Power switch**
Ensure that the knob of the pressure switch is in the "OFF" position (Fig. 2). If the plug is connected to a receptacle while the knob is in the "ON" position, the compressor will start operating immediately and can cause serious injury.

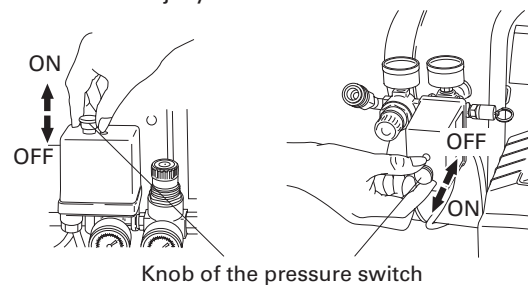

⟨ EC 10SB(SL) ⟩

⟨ EC 12 ⟩

Fig. 2

- Extension cord**
When the work area is far away from the power source, use an extension cord of sufficient thickness and rated capacity (refer page 6). The extension cord should be kept as short as practicable.

⚠ WARNING: Damaged cord must be replaced or repaired.

4. Confirm the power receptacle
If the power receptacle only loosely accepts the plug, the receptacle must be repaired. Contact the nearest electric store for repair service.
If such a faulty receptacle is used, may cause overheating, resulting in a serious hazard.
5. Dipstick insertion and oil level check
(If your compressor is EC10SB(SL) this step is not necessary.)
Use a screwdriver or similar tool to remove the plastic cap on the lower part of the cylinder (Fig. 3).

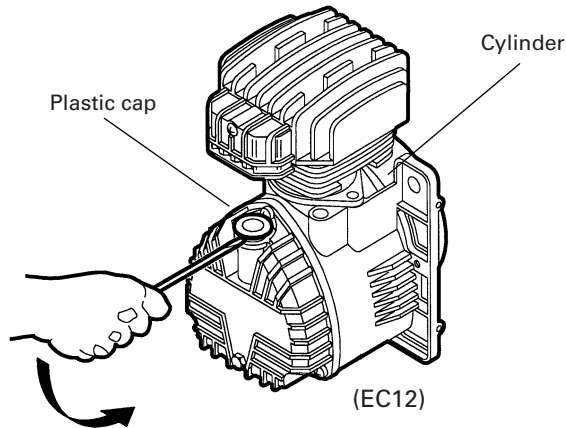

Fig. 3

Insert the accessory dipstick all the way to the bottom. Remove the dipstick and make sure the oil level is within the range of the dipstick notches (Fig. 4).

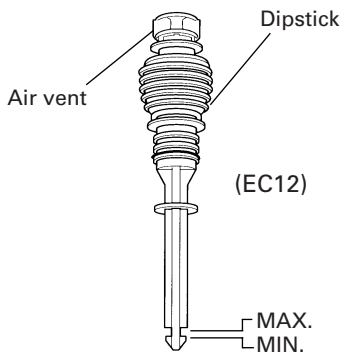

Fig. 4

⚠ WARNING: Drain tank to release air pressure before removing the dipstick.

⚠ WARNING: Make sure air vent in dipstick is free from debris. If air vent is blocked pressure can build in crankcase causing damage to compressor and possible personal injury.

When the oil volume is insufficient, refer to the section "Oil change-oil topping off" on page 10 for a description of how to supply the oil.

6. Right running position
Position the compressor on a flat surface, in a well ventilated area away from atmospheric agents and not in explosive areas.

TRANSPORT

Push the knob of the pressure switch to "OFF" and disconnect it from the power source before move the compressor. Transport the compressor in the correct manner.

OPERATION

1. Start up
Insert the plug into the receptacle and start the compressor by pulling the knob of the pressure switch to "ON" (Refer to Fig. 2).

⚠ WARNING: Do not stop or start the compressor by use of the plug. Always use "ON/OFF" knob located on the pressure switch.

The operation of the compressor is automatic and is controlled by the pressure switch which stops it when the pressure in the air-tank reaches the maximum level and restart it when the air pressure drops during use to the restart level.

The motor of the compressor is fitted with a thermal protection inside-the-wrap, which stops the compressor when the temperature is too high. Should this be tripped, the compressor will restart automatically after 15-20 minutes.

2. Adjustment of working pressure
Unlock the knob of the pressure reducer pulling it up, adjust the pressure to the required level by turning the knob clockwise to increase and counterclockwise to decrease.
A pressure gauge (B) is provided to know when the required pressure is reached, lock the knob by pushing it down firmly (Refer to Fig. 5).
When adjusting the pressure, check and make sure that a pressure gauge for the tank has the pressure level that is higher than that of the pressure to be adjusted.
It is also imperative that you make adjustment by slowly starting up the pressure from the level that is lower than the pressure to be adjusted.

⚠ WARNING: Check the manufacturer's maximum pressure rating for nailers, staplers and accessories. Compressor outlet pressure must be regulated so as to never exceed the maximum pressure rating of the nailers, staplers and accessories.

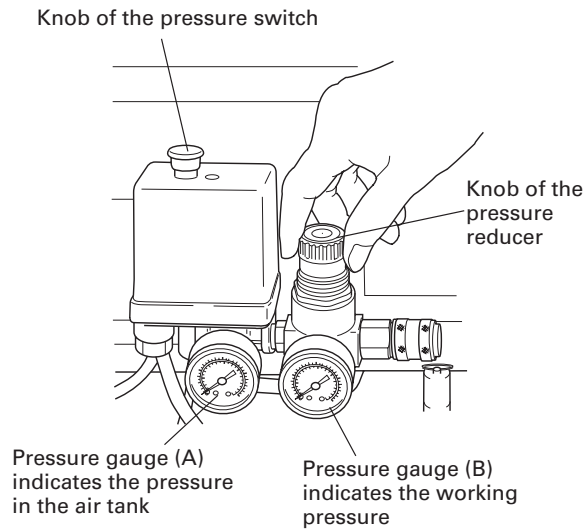

EC 10SB(SL)

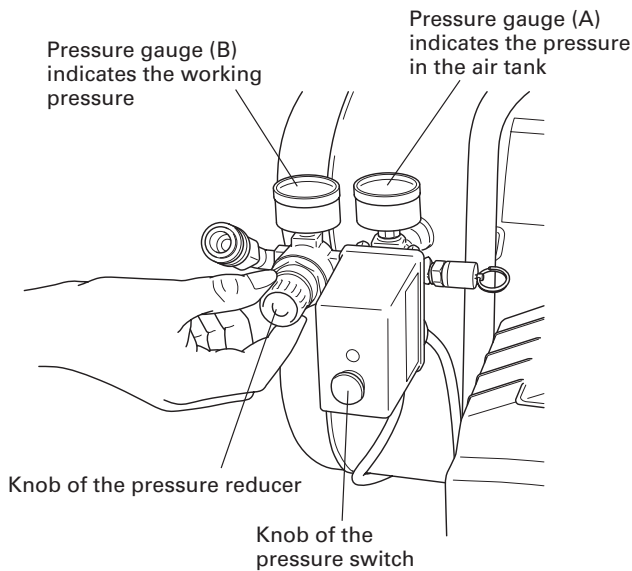

EC 12

Fig. 5

3. Shutdown

- (1) Push the knob of the pressure switch to "OFF" (Refer to Fig. 1 and Fig. 2).
- (2) Unplug the plug from power source.
- (3) Open the drain cock located at the lower part of the tank (Fig. 6).

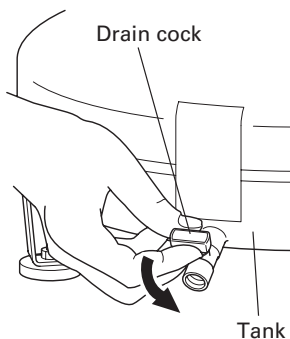

Fig. 6

MAINTENANCE

⚠ WARNING: Disconnect the compressor from the power source and remove the compressed air from the air tank before performing the maintenance operations. Allow the compressor to cool before performing the maintenance operations.

1. Cleaning the intake filter

Remove the intake filter (Refer to Fig. 1) every 50 hours or once a week and clean the inside of the intake filter and the filter element with compressed air (Fig. 7).

Use a phillips screwdriver to disassemble intake filter.

⚠ WARNING: Never clean filter element with a flammable liquid or solvent.

⚠ CAUTION : Do not operate without the intake filter.

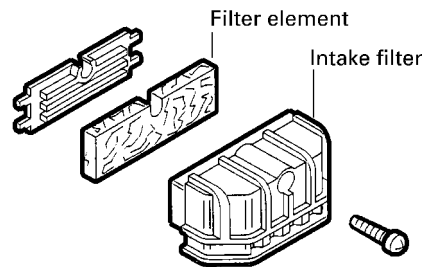

Fig. 7

NOTE: Replace the filter element when it becomes dirty.

2. Draining tank

Drain tank daily or after 4 hours of use. Open drain fitting and tilt compressor to empty accumulated water (Refer to Fig. 6).

3. Oil change-oil topping off (Only for EC12)

⚠ CAUTION : Overfilling with oil will cause premature compressor failure. Do not overfill.

- (1) Within the first 50 hours of operation, completely replace the oil of the pumping element. Unfasten the oil drain cap on the casing cover, drain all the oil, and screw the cap back on (Refer to Fig. 8).

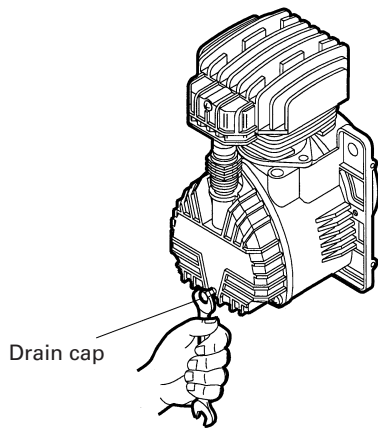

Fig. 8

Pour oil into the hole of the dipstick.
To the level indicated on the dipstick (Refer to Fig. 4).
For oil replacement, follow the table below.

OIL TYPE

SAE 5W50 SYNTHETIC OIL (-20°+120°F) For both summer and winter use
SAE 10W40 MULTI-GRADED OIL (+50°+120°F) For warm weather use only

- (2) Check the oil level of the pumping element every 50 hours or once a week.
- (3) Change the oil every 300 working hours or every 6 months.

SERVICE AND REPAIRS

All quality compressors will eventually require servicing or replacement of parts because of wear from normal use. To assure that only authorized replacement parts will be used, all service and repairs must be performed by a HITACHI AUTHORIZED SERVICE CENTER, ONLY.

NOTE: Specifications are subject to change without any obligation on the part of the HITACHI.

EC 10 SB (SL)

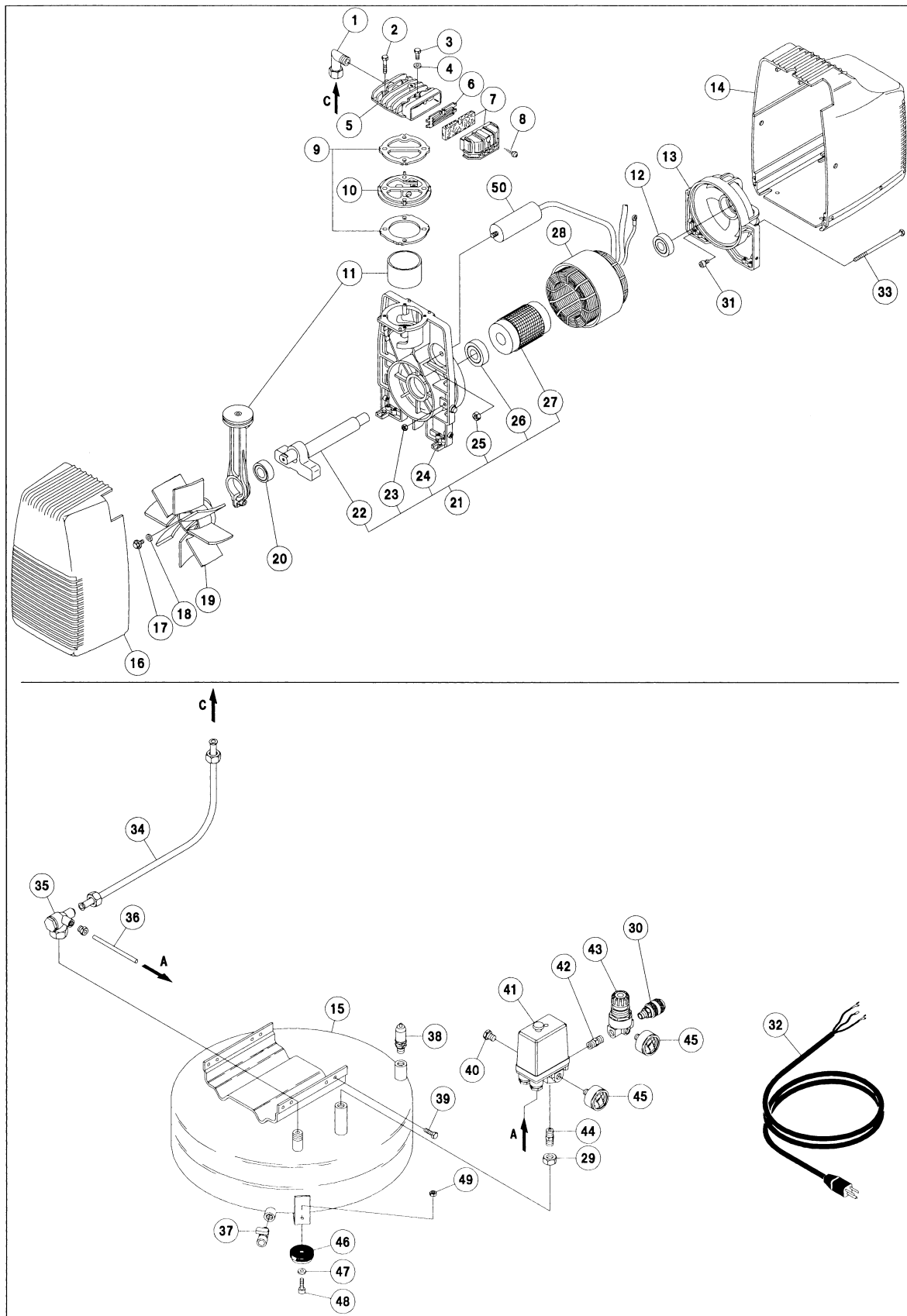

EC10SB(SL)

Item No.	Code No.	Part Name	Q'ty	Reference No.
1	881-455	Joint	1	7084080000
2	881-551	Screw	4	7011220000
3	881-415	Screw	1	7014300000
4	881-414	Washer	1	7030780000
5	881-456	Head	1	7570550000
6	881-453	Filter plate	1	7458340000
7	881-620	Intake filter	1	4085010000
8	881-450	Screw	1	7012010000
9	882-612	Set of gaskets	1	4085100000
10	882-595	Monoplate	1	4200020000
11	882-613	Conrod-cylinder kit	1	4190350000
12	881-478	Bearing	1	7060010000
13	881-409	Cover	1	7640100000
14	881-411	Motor housing	1	7150580000
15	—	Tank	1	5154280008
16	881-398	Compressor housing	1	7150590000
17	881-399	Screw	1	7011040000
18	881-573	Washer	1	7030190000
19	882-614	Fan	1	7200190000
20	882-615	Bearing	1	7060550000
21	882-616	Carter / Shaft / Rotor	1	4280640000
22	882-617	Crankshaft	1	5040860008
23	881-401	Nut	2	7021010000
24	881-402	Carter	1	7670040000
25	882-618	Nut	1	7020240000
26	882-619	Bearing	1	7060320000
27	884-600	Rotor	1	7660240000
28	884-601	Wound stator	1	4012690000
29	881-504	Blocking nut	1	7023040000
30	884-602	Tap	1	7130510000
31	884-444	Screw	1	7013060000
32	884-603	Infeed cable	1	7329000000
33	881-480	Tension rod	2	7018010000
34	882-608	Infeed tube	1	7232500000
35	881-494	Non return valve	1	7190040000
36	881-496	Tube	1	7230010000
37	882-610	Discharge tap	1	7130440000
38	881-493	Safety valve	1	7192270000
39	881-410	Screw	4	7012290000
40	881-513	Plug	1	7090070000
41	884-604	Pressure switch	1	7250240000
42	881-511	Joint	1	7081090000
43	881-510	Pressure reducer	1	7100120000
44	881-505	Joint	1	7081140000
45	882-606	Pressure gauge	2	7110240000
46	881-577	Rubber	4	7360140000
47	881-573	Washer	4	7030190000
48	881-399	Screw	4	7011040000
49	881-401	Nut	4	7021010000
50	884-605	Capacitor	1	7310320000

Parts are subject to change without any obligation on the part of HITACHI due to improvements.

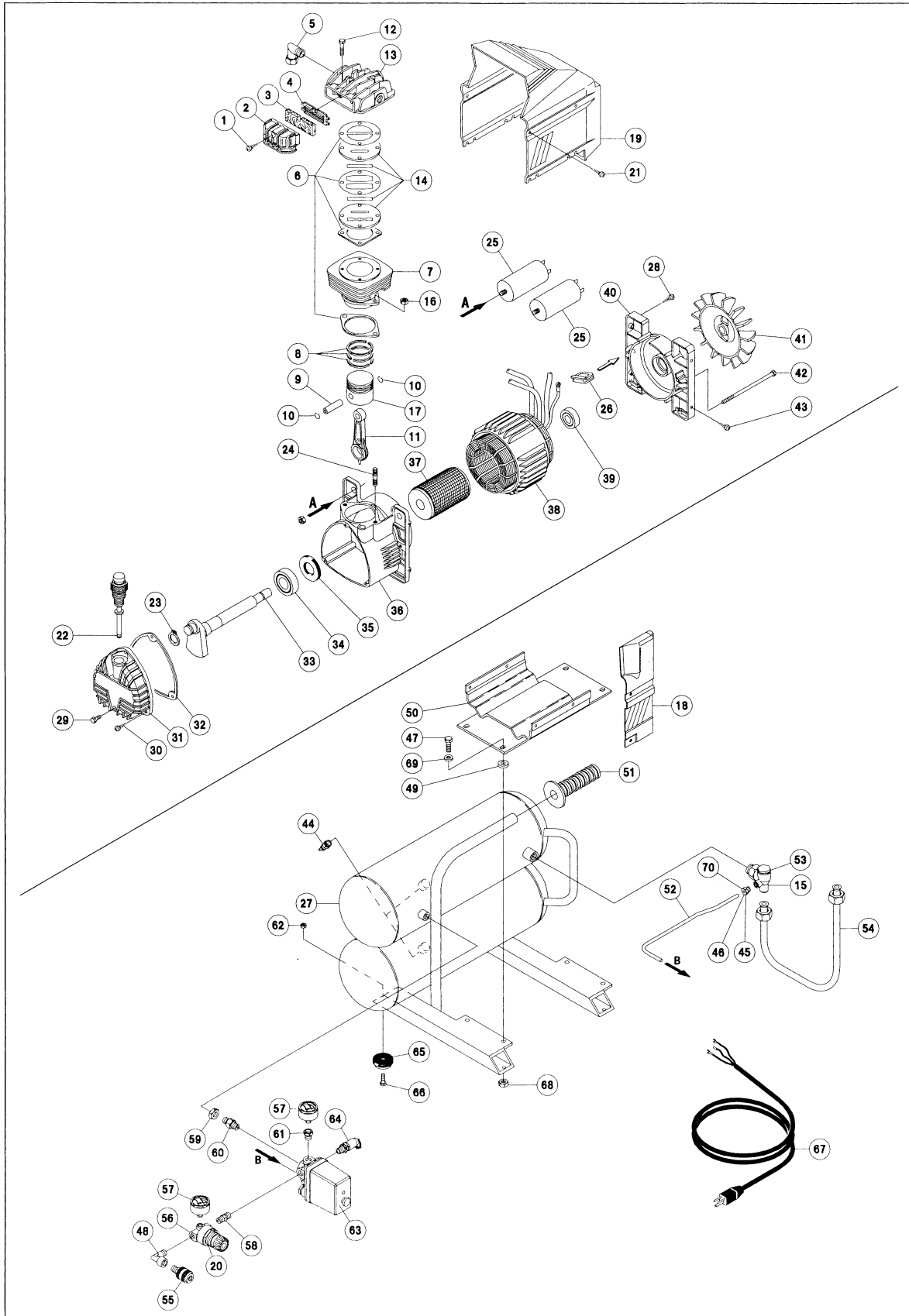

EC12

Item No.	Code No.	Part Name	Q'ty	Reference No.
1	881-450	Screw	1	7012010000
2	881-554	Intake filter	1	7210430000
3	881-553	Filtering element	1	7210010000
4	881-453	Filter plate	1	7458340000
5	881-590	Joint	1	7084190000
6	881-555	Set of gaskets	1	4082200000
7	881-591	Cylinder	1	7575070000
8	881-559	Piston rings	1	4080020000
9	881-560	Piston pin	1	7050020000
10	881-463	Ring	2	7041010000
11	881-592	Con rod	1	5150150008
12	881-551	Screw	4	7011220000
13	881-593	Head	1	7570060000
14	881-594	Valve plate	1	7459480000
15	—	Rubber N/R valve	1	7193350000
16	881-489	Nut	2	7020070000
17	881-567	Piston	1	7220020000
18	881-569	Pipe protection	1	7154120000
19	881-568	Housing	1	7150421000
20	—	Rubber membrane	1	7101130000
21	881-492	Screw	4	7012060000
22	881-469	Dipstick	1	7181060000
23	881-463	Ring	1	7041010000
24	881-465	Stud bolt	2	7015020000
25	881-488	Capacitor	2	7310140000
26	881-487	Chock	1	7500030000
27	—	Tank	1	4300420000
28	884-444	Screw	1	7013060000
29	884-450	Drain cap	1	7011430000
30	881-595	Screw	3	7013090000
31	881-470	Carter cover	1	7650020000
32	881-473	Gasket	1	7078460000
33	881-596	Crank shaft	1	5040790008
34	881-478	Bearing	1	7060010000
35	881-474	Smim ring	1	7071020000
36	884-448	Crank case	1	5070320008
37	881-597	Rotor	1	7660240000
38	881-598	Motor casing	1	4012050000
39	881-466	Bearing	1	7060060000
40	882-585	Cover	1	5110061008
41	881-599	Fan	1	7201280000
42	881-480	Tension rod	2	7018010000
43	881-410	Screw	4	7012290000
44	882-610	Discharge tap	2	7130440000
45	—	Air hose connector	1	7024070000
46	—	Ferrule	1	7041020000
47	881-571	Screw	4	7011100000
48	881-600	Joint	1	7080180000
49	881-583	Rubber	4	7360260000
50	881-570	Base	1	5011410008
51	881-582	Rubber handle	1	7280070000
52	881-601	Tube	1	4084960000
53	881-581	Non return valve	1	7190040000
54	881-602	Infeed tube	1	4084970000
55	884-602	Tap	1	7130510000

Item No.	Code No.	Part Name	Q'ty	Reference No.
56	881-510	Pressure reducer	1	7100120000
57	882-606	Pressure gauge	2	7110240000
58	881-511	Joint	1	7081090000
59	881-504	Blocking nut	1	7023040000
60	881-505	Joint	1	7081140000
61	881-576	Joint	1	7085180000
62	881-401	Nut	4	7021010000
63	884-604	Pressure switch	1	7250240000
64	881-493	Safety valve	1	7192270000
65	881-603	Rubber	4	7270060000
66	881-604	Screw	4	7011030000
67	884-603	Infeed cable	1	7329000000
68	881-589	Nut	4	7021030000
69	881-572	Washer	4	7030030000
70	—	Bolt + Ferrule	1	4084960000

Parts are subject to change without any obligation on the part of HITACHI due to improvements.

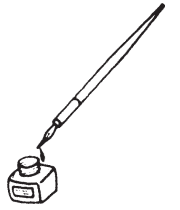

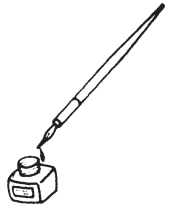

 **Hitachi Koki Co., Ltd.**

312
Code No. C99128411
Printed in Italy

Free Manuals Download Website

<http://myh66.com>

<http://usermanuals.us>

<http://www.somanuals.com>

<http://www.4manuals.cc>

<http://www.manual-lib.com>

<http://www.404manual.com>

<http://www.luxmanual.com>

<http://aubethermostatmanual.com>

Golf course search by state

<http://golfingnear.com>

Email search by domain

<http://emailbydomain.com>

Auto manuals search

<http://auto.somanuals.com>

TV manuals search

<http://tv.somanuals.com>