

Cooker with electric ventilated oven and ceramic hob

Instructions for installation and use

K6C32/G

K6C320/G



GB **Cooker with electric ventilated oven and ceramic hob**
Instructions for installation and use

Important safety warnings

To maintain the **EFFICIENCY** and **SAFETY** of this appliance, we recommend:

- call only the **Service Centers** authorized by the manufacturer
- always use **original Spare Parts**

- 1 This appliance is intended for non-professional use within the home.
- 2 These instructions are only for those countries whose symbols appear in the booklet and on the matriculation plate of the appliance.
- 3 **This owner's manual is for a class 1 appliance (installed independently) or class 2, sub-class 1 appliances (installed between two cabinets).**
- 4 Before using your appliance, read your owner's manual carefully since it provides important instructions for the safe installation, use and maintenance of your cooker. Keep in a safe place for future reference.
- 5 After unpacking the appliance, check that it is undamaged and that no parts are missing. If you are in any doubt, consult a qualified technician. All packaging, (plastics bags, polystyrene foam, nails, etc.) should be kept out of the reach of children as it could be dangerous.
- 6 The appliance must be installed according to the manufacturer's instructions by a qualified technician. Improper installation may cause damage to persons, animals or objects for which the manufacturer cannot be held responsible.
- 7 The electrical safety of this appliance is guaranteed only if it is connected to a properly earthed system which complies with the electrical safety standards in force. This fundamental safety requirement is to be verified in any case. If you have any doubts, consult a qualified electrician. The manufacturer cannot be held responsible for any damages caused by an appliance which has not been earthed.
- 8 Before connecting the appliance, check that the information on the data plate corresponds to the electric mains of your home.
- 9 Check that the electric capacity of the system and sockets correspond to the maximum power of the appliance indicated on the data plate. If in doubt, call a qualified technician.
- 10 When installing the appliance, an omnipolar circuit-breaker with a minimum contact opening of 3 mm must be used.
- 11 Should the socket and the plug of the appliance be incompatible, the socket must be replaced by a skilled electrician, who is also to check if the cross-section of the socket cables will support the absorbed power of the appliance. Adaptors, multiple sockets and/or extension leads should generally not be used.
- 12 Do not leave the appliance unnecessarily ON. Turn off the mains switch when the appliance is not being used.
- 13 Ventilation and heat dispersion outlets should always be unobstructed.
- 14 Never replace the power supply cable yourself. Damaged cables may only be replaced by an authorised service centre.
- 15 This appliance must only be used for the purpose for which it has been designed. Any other use (for example: heating rooms) must be considered improper and, therefore, dangerous. The manufacturer is not liable for damages resulting from improper, incorrect and negligent use.
- 16 The use of any electrical appliance involves the observance of some basic rules. In particular:
 - do not touch the appliance with wet or damp hands or feet
 - do not use the appliance whilst barefoot
 - do not use extension leads other than with the utmost caution
 - do not pull the supply cable or the appliance itself to disconnect the plug from the socket.
 - do not expose the appliance to weather agents (rain, sun, etc.)
 - do not allow unsupervised children or inexperienced persons to use the appliance
- 17 Always disconnect the appliance before cleaning it or carrying out maintenance work by turning off the mains switch or removing the plug from the socket.
- 18 If you decide to stop using this appliance, it is recommended that the supply cable is cut and that all parts of the appliance are removed, particularly for the safety of children who might use the appliance as a toy.
- 19 Use only stable, flat-based pans. They should be placed on the hobs with the handles turned inwards so that they are not accidentally knocked off.
- 20 Some parts of the appliance, in particular the electric plates, remain hot for a long time after use. Be careful not to touch them.
- 21 Do not use flammable liquids (alcohol, petrol...) near the appliance when in use.
- 22 When using small household appliances near the cooker hobs, make sure that the power supply cable does not touch any hot parts.
- 23 Make sure the knobs are in the "•"/"o" position when the appliance is not in use.
- 24 **When the appliance is in use, the heating elements and some parts of the oven door become extremely hot. Make sure you don't touch them and keep children well away.**
- 25 If the cooker is placed on a pedestal, take the necessary precautions to prevent the same from sliding off the pedestal itself.
- 26 If the surface of the glass breaks, disconnect the appliance immediately. For repairs call only an authorised after-sales servicing centre and request the use of original spare parts only. Failure to comply with the above may compromise the safety of the appliance.
- 27 The vitreous china hob is resistant to temperature fluctuations and shockproof. Remember however that sharp kitchen tools or cutters may break the surface of the hob. If this happens, unplug the cooker immediately from the mains and call your local servicing centre.
- 28 Remember that the cooking surface remains hot for at least half an hour after you switch off the surface. Do not place containers or other objects on the hot surface.
- 29 Do not turn on the cooking surfaces if there are sheets of aluminium foil or plastic on the hob.
- 30 **Preliminary instructions.** The glass sealant utilised may leave traces of grease on the glass. Remember to wipe these away with a normal non abrasive detergent before you turn on the appliance. During the first few hours of use there may be a smell of rubber which will disappear very quickly.
- 31 **WARNING: Do not look at the halogen lamps in the cooking zones for long if they are present.**

Installation

Important: The installation instructions for cooking ranges shall include a recommendation that such appliances should not be placed adjacent to a door access to minimise the likelihood of persons using the door making contact with pans on the hob surface.

Important: before making any adjustments, maintenance etc. to the cooker, first ensure that it is disconnected from the electricity supply.

Positioning

The appliance can therefore be installed next to cabinets, provided the height does not exceed that of the hob.

Important: The hob should never be installed in proximity of a door access. People opening and closing the door could come into contact with pots or pans cooking on the hob.

Levelling Your Appliance (only on certain models)

4 support feet which are adjusted using screws are located in the lower part of the cooker. These level off the oven when necessary. It is essential that the cooker be standing level.

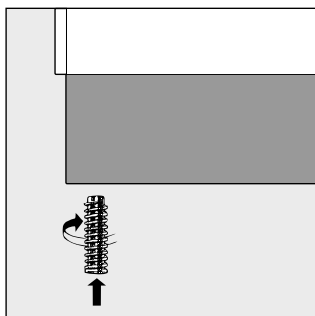

Mounting the legs (only on certain models)

Press-fit legs are supplied which fit under the base of your cooker.

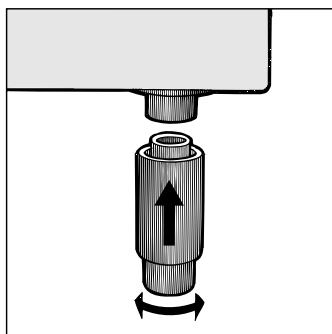

Electrical connection

Electric cookers come without a power supply cable. The cooker is designed to operate on an electricity supply which conforms to the electrical data shown on the Rating Plate. The cooker can be connected to the mains only after removing the back panel of the cooker itself with a screwdriver.

N.B.: the following installation procedure must be carried out by a qualified electrician. The electrical installation must comply with the IEE Regulations, Building & local By-Lays.

For the installation of the feeding cable carry out the following operations:

- Unscrew screw "V" (see fig. A)
- Pull and open the junction blok lid

Important: the wires in the mains lead are coloured in accordance with the following code:

Green & Yellow	Earth
Blue	Neutral
Brown	Live

As the colours of the wires in the mains lead may not correspond with the coloured markings identifying the terminals in your plug, proceed as follows:

Green & Yellow wire to terminal marked "E" or \perp or coloured Green or Green & Yellow.

Brown wire to terminal marked "L" or coloured Red.

Blue wire to terminal marked "N" or coloured Black (see fig. B).

- fix the feeding cable in the special cable stop and close the cover.

N.B.: the power supply cable must have these minimum requirements:

Type: H05RR-F

Section: 3x4 mm²

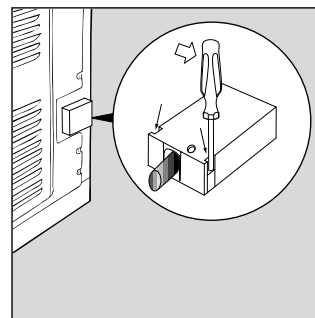

Fig. A

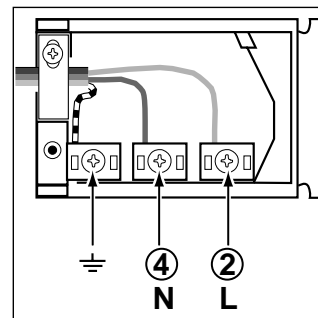

Fig. B

Connecting the supply cable to the mains

WARNINGS: THIS APPLIANCE MUST BE EARTHED.

Important: The cooker must be connected to the mains by a switched (double pole) cooker outlet correctly fused with a capacity appropriate to that shown on the cooker Rating Plate. All electrical wiring from the consumer unit to the cooker, via the switched double pole cooker outlet, must be of an acceptable type and current rating as above.

Note: the supply cable must be positioned so that it never reaches at any point a temperature 50°C higher than the room temperature. The cable must be routed away from the rear vents.

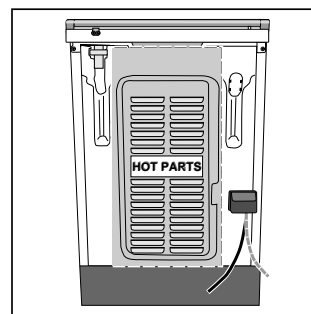

Technical Characteristics

Inner dimensions of the oven:

Width: 43.5 cm
Depth: 40 cm
Height: 32 cm

Inner Volume of the Oven:

56 lt

Innder dimensions of the plate warmer:

Width: 46 cm
Depth: 42 cm
Height: 8.5 cm

ENERGY LABEL

Directive 2002/40/EC on the label of electric ovens

Norm EN 50304

Declared energy consumption for Forced convection Class
heating mode: Fan assisted

Mains frequency and voltage of the electrical section

Model	Electric section	
	Voltage	Power (W)
K6C32/G K6C320/G	240V~ 50/60 Hz	8600

Voltage and Frequency of Power Supply:

see data plate



This appliance conforms with the following European Economic Community directives:

- 73/23/EEC of 19/02/73 (Low Voltage) and subsequent modifications;
- 89/336/EEC of 03/05/89 (Electromagnetic Compatibility) and subsequent modifications;
- 93/68/EEC of 22/07/93 and subsequent modifications.
- 2002/96/EC

The European Directive 2002/96/EC on Waste Electrical and Electronic Equipment (WEEE), requires that old household electrical appliances must not be disposed of in the normal unsorted municipal waste stream. Old appliances must be collected separately in order to optimise the recovery and recycling of the materials they contain and reduce the impact on human health and the environment. The crossed out "wheeled bin" symbol on the product reminds you of your obligation, that when you dispose of the appliance it must be separately collected. Consumers should contact their local authority or retailer for information concerning the correct disposal of their old appliance.

The cooker with electric ventilated oven and ceramic hob

- A Control Panel
- B Oven Rack
- C Dripping Pan or Baking Sheet
- D Adjustable Feet
- G Selector Knob
- H The green pilot lamp
- I Electric plate knob
- L Thermostat Light
- M Cooking Control Timer Knob
- N Variable grill Knob

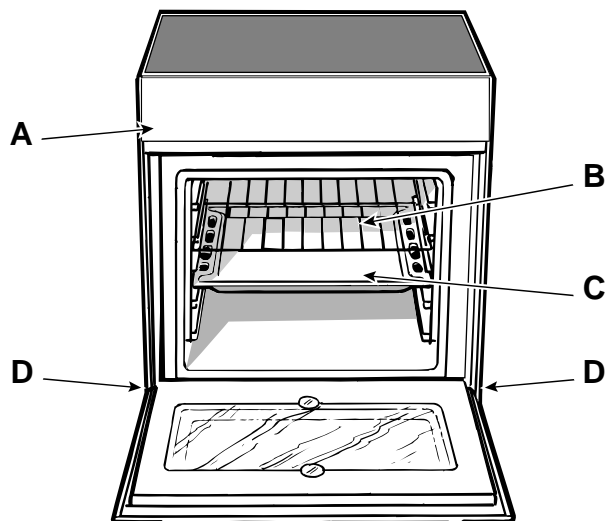
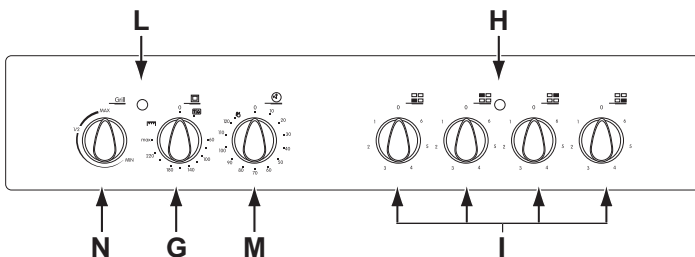

The different functions and uses of the oven

The various functions included in the cooker are selected by operating the control devices located on the cooker control panel.

Notice: The first time you use your appliance, we recommend that you set the thermostat to the highest setting and leave the oven on for about half an hour with nothing in it, with the oven door shut. Then, open the oven door and let the room air. The odour that is often detected during this initial use is due to the evaporation of substances used to protect the oven during storage and until it is installed.

Attention: Only use the bottom shelf of the oven when using the rotisserie to cook (where present). For all other types of cooking, never use the bottom shelf and never place anything on the bottom of the oven when it is in operation because this could damage the enamel. Always place your cookware (dishes, aluminium foil, etc. etc.) on the grate provided with the appliance inserted especially along the oven guides.

Attention: to use the oven in manual mode without the cooking control timer, match the indicator on the control panel with the  symbol on the timer knob.

Using the oven

When the oven control knob (**G**) is turned in a clockwise direction to the symbol  the fan and oven light will come on to assist in the defrosting of frozen food. Rotating further to the complete range of temperatures shown on the dial you can choose which is most suitable for the food you are going to cook. The temperature is reached automatically and controlled by the oven thermostat (from 60°C to 240°C).

Note: Whilst using tag oven for conventional cooking knob (**O**) must be set with "MAX" in line with the reference mark on the control panel.

Grill

The top heating element will come on. On this setting, food is cooked by the thermal radiation given off in the downward direction by the electric heating element. The very high temperature and direct heat of the grill make it possible to brown meats on the surface while locking in the juices to keep them tender.

Important: when using the grill, the oven door must be left partly open by positioning the deflector "D" between door and panel to prevent the cooker knobs from overheating.

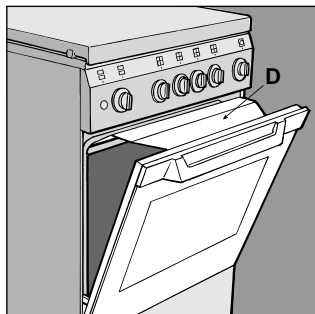



Oven Light

The light comes on when the "G" knob is turned to the  setting. The light illuminates the oven and remains on when any of the heating elements is turned on.

Thermostat Light (L)

This light indicates that the oven is heating. When it turns off, the temperature inside the oven has reached the setting made with the thermostat knob. At this point, the light will turn on and off as the oven maintains the temperature at a constant level.

Cooking Control Timer Knob (only a few models)

Some models are equipped with a timer program to control when the oven shuts off during cooking. To use this feature, you must wind the "M" knob one full turn in the counter-clockwise direction ; Then, turn the knob in the clockwise direction , to set the time by matching up the indicator on the control panel with the number of minutes on the knob.

At the end of the programmed length of time, the timer will sound and automatically turn off the oven.

Attention: to use the oven in manual mode without the cooking control timer, match the indicator on the control panel with the  symbol on the timer knob.

When the oven is not in use, the cooking control timer can be used like a normal timer.

Using the grill pan kit

Position the handle on the grill pan so that it fits into the small recess (fig. 1), tilt it upwards and slide it towards the centre (fig. 2).

The food must be placed on the rack in the grill pan. Position the grill pan on top of the oven rack. The best results are achieved by placing the oven rack on the uppermost shelves. Pouring a little water into the grill pan will make the collection of grease particles more efficient and prevent the formation of smoke.

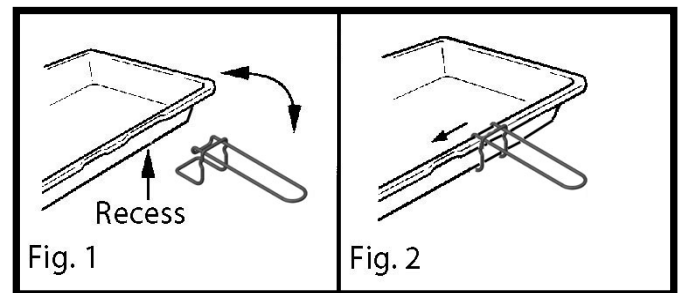

Cooking advice

When using the oven, only one rack or drip pan should be used at a time. The rack or pan should be inserted into the bottom or top guides depending on whether the food needs more heat from the top or bottom.

Preheating

If the oven must be preheated (this is generally required for leavened foods), we recommend using the "conventional" oven feature which makes it possible to reach the temperature desired in a very short time. After the oven has been preheated, the red indicator light (I) will turn off. At this point, you can select the most suitable setting to cook the dish.

Cooking Fish and Meat

Meat must weigh at least 1 Kg in order to prevent it from drying out. When cooking white meat, fowl and fish, use low temperature settings (150°C-175°C). For red meat that should be well done on the outside while tender and juicy in the inside, it is a good idea to start with a high temperature setting (200°C-220°C) for a short time, then turn the oven down afterwards. In general, the larger the roast, the lower the temperature setting. Place the meat on the centre of the rack and place the drip pan beneath it to catch the fat.

Make sure that the rack is inserted so that it is in the centre of the oven. If you would like to increase the amount of heat from below, use the low rack heights. For savory roasts (especially duck and wild game), dress the meat with lard or bacon on the top.

Cooking Pastries

Always preheat the oven when cooking pastries. Do not open the door in order to prevent the pastry from dropping. The batter or dough should not be too liquidy so that the cooking time is not excessive. In general:

Pastry is too dry

Increase the temperature by 10°C and reduce the cooking time.

Pastry dropped

Use less liquid or lower the temperature by 10°C.

Pastry is too dark on top

Place it on a lower rack, lower the temperature, and increase the cooking time.

Cooked well on the inside but sticky on the outside

Use less liquid, lower the temperature, and increase the cooking time.

The pastry sticks to the pan

Grease the pan well and sprinkle it with a dusting of flour.

I used more than one level and they are not all at the same cooking point

Use a lower temperature setting. It is not necessary to remove the food from all the racks at the same time.

Using the Grill

Grilling may be carried out with a two stage heating element situated in the top of the oven chamber. The centre, or the complete area of the grill can be selected by turning the oven control knob (G) in a clockwise direction to align the symbols |▽▽▽| with the mark on the control panel. The variable temperature control (O) is positioned to right of the oven knob. This knob will provide varying grill temperatures when rotated from "max" to "min" and may be adjusted to vary the level of heat at any time during the grilling operation.

To operate the grill

1. Turn the oven control knob (G) clockwise until the required grilling symbol is in line with the mark on the control panel. The element is now "on".
2. The variable grill control (N) can now be operated to select the required heat.

When utilizing the grill, place the rack at the lower levels (see cooking table). To catch grease or fat and prevent smoke, place a drip pan at the bottom rack level.

Practical advice for using the electric plates

The control knobs for the hob electric hotplates (I)

The cookers can be fitted with normal and rapid electric hotplates in a variety of combinations (the rapid hotplates can be distinguished from the rest by the red boss in the centre of the same). To avoid any heat loss and damage to the hotplates, we advise you to use pans with a flat bottom, with a diameter which matches that of the hotplate itself. The table contains the different settings indicated on the knobs and the use for which the hotplates are recommended.

Setting	Normal or Fast Plate
0	Off
1	Cooking vegetables, fish
2	Cooking potatoes (using steam) soups, chickpeas, beans.
3	Continuing the cooking of large quantities of food, minestrone
4	For roasting (average)
5	For roasting (above average)
6	For browning and reaching a boil in a short time.

Electric hotplate indicator light (H)

This light comes on when any of the electrical hotplates on a hob which features electric hotplates have been turned on.

User's instructions the ceramic hob

Description

The hobs have been provided with radiant electric heaters. These heaters are incorporated under the surface of the hob as zones which redden while they are in use.

A. Cooking area (A).

B. A lights which indicate whether the corresponding heaters are at a temperature in excess of 60° C; even if the hob/zone has been switched off.

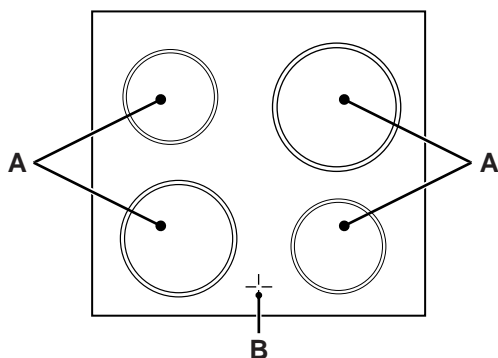

Description of the heating elements

The **radiant heating elements** are composed of circular heating elements. They only become red after being turned on for 10-20 seconds.

Instructions for using the pyroceram top

To obtain the best results from your hob, there are some basic rules to follow when cooking or preparing food.

- All types of pots and pans may be used on the ceramic glass cooktop. However, the bottom surface must be perfectly flat (see Fig. A). Naturally, the thicker the bottom of the pot or pan, the more uniformly the heat is distributed.

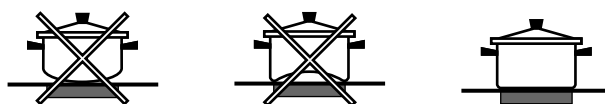

Fig. A

- Make sure that the base of the pan completely covers the cooking ring, so as to make full use of the heat produced (Fig. B)

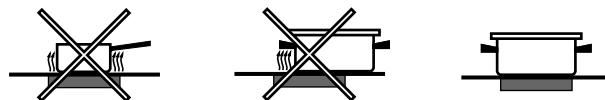

Fig. B

- Always make sure that the pan base is always dry and clean so as to guarantee proper contact as well as longer-lasting pans and the long life-span of the hob.
- Do not use the same pans which are used for cooking on gas burners. The heat strength of gas burners may deform the pan base and will not give the same results if it is subsequently used on a glazed ceramic hob.

Cooker routine maintenance and cleaning

Disconnect the oven from the source of electricity before performing any maintenance or cleaning. To ensure a long life for your oven, clean it frequently and carefully, keeping in mind that:

- **Do not use steam equipment to clean the appliance.**
- the enamelled parts and the self-cleaning panels should be washed with warm water without the addition of abrasive powders or corrosive substances which could damage the finish;
- stainless steel may become marked if it comes into contact with very hard water or harsh detergents (containing phosphorous) for long periods of time. After cleaning, it is advisable to rinse thoroughly and dry. It is also recommended to dry any water drops;
- avoid dirt and grease accumulating on the control panel by cleaning it frequently. Use non-abrasive sponges or soft cloths to avoid scratching enamelled or shiny steel parts.

Cleaning the hob surface

Prior to cooking, the hob surface should always be cleaned using a damp cloth to remove any dust or stray food particles. The hob surface should be regularly cleaned with a lukewarm solution of water and a mild detergent. Periodically it may be necessary to use a proprietary ceramic hob cleaner. First remove all spilt food and fat with a window scrape, preferably the razor blade type **CERA^{luneta}** (not supplied) or, failing that, the fixed blade razor edge type (see Fig. A). Then clean the hob while it is still warm to the touch with a suitable cleaner and paper towel.

Then rinse it and wipe it dry with a clean cloth. If aluminium foil or plastic items are accidentally allowed to melt on the hob surface they should be **immediately** removed from the hot cooking area with a scraper. This will avoid any possible damage to the surface. This also applies to sugar or any food with a high sugar content.

Do not use abrasive sponges or scourers of any type. Corrosive cleaners such as oven sprays and stain removers should also not be used (see Fig. B).

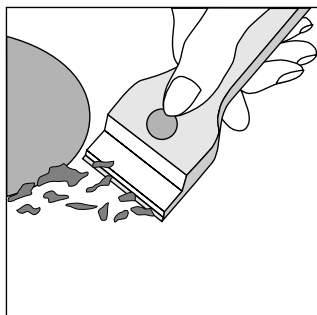

Fig. A

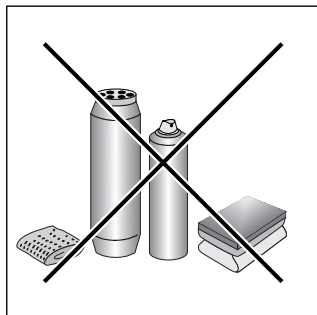
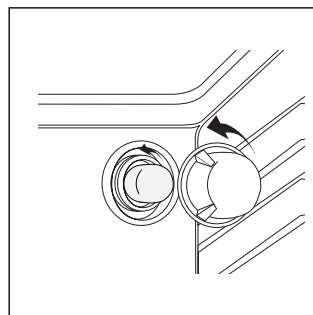

Fig. B

Glass ceramic hob cleaners	Available from
Window scraper Razor blade scrapers	DIY Stores
Replacement blades	DIY Stores, supermarkets, chemists
COLLO luneta HOB BRITE Hob Clean SWISSCLEANER	Boots, Co-op stores, department stores, Regional Electricity Company shops, supermarkets

Replacing the oven lamp

- Unplug the oven from the mains;
- Remove the glass cover of the lamp-holder;
- Remove the lamp and replace with a lamp resistant to high temperatures (300°C) with the following characteristics::
 - Voltage 230V
 - Wattage 25W
 - Type E14
- Replace the glass cover and reconnect the oven to the mains.



Food to be cooked	Wt. (wt)	Cooking position of shelves from bottom	Temperature (°C)	Variable grill	Pre-heating time (min)	Cooking time (min.)
Pasta						
Lasagne	2.5	3	210	MAX	-	75-80
Cannelloni	2.5	3	210		-	75-80
Oven-baked noodles	2.5	3	210		-	75-80
Meat						
Veal	1.7	3	230	MAX	-	85-90
Chicken	1.5	3	220		-	110-115
Turkey	3.0	3	MAX		-	95-100
Duck	1.8	3	230		-	120/125
Rabbit	2	3	230		-	105/110
Pork	2.1	3	230		-	100/110
Lamb	1.8	3	230		-	90-95
Fish						
Mackerel	1.1	3	210-230	MAX	-	55-60
Dentex	1.5	3	210-230		-	60-65
Trout baked in paper	1.0	3	210-230		-	40-45
Pizza						
Napolitan	1.0	3	MAX	MAX	15	30-35
Cake						
Biscuits	0.5	3	180	MAX	15	30-35
Tarts	1.1	3	180		15	30-35
Chocolate cake	1	3	200		15	45-50
Raised Cakes	1	3	200		15	50/55
Grill cooking						
Toast	n.° 4	4		3/4	5	5-6
Pork chops	1.5	4			5	20-30
Mackerel	1.1	4			5	20-30

Note: cooking times are approximate and may vary according to personal taste.



Indesit Company
viale Aristide Merloni, 47
60044 Fabriano (AN) Italy
tel. +39 0732 6611
www.indesit.com

Cucina con forno elettrico ventilato variabile e piano VTC (Spec. GB)
06/05 - 195044862.01

Free Manuals Download Website

<http://myh66.com>

<http://usermanuals.us>

<http://www.somanuals.com>

<http://www.4manuals.cc>

<http://www.manual-lib.com>

<http://www.404manual.com>

<http://www.luxmanual.com>

<http://aubethermostatmanual.com>

Golf course search by state

<http://golfingnear.com>

Email search by domain

<http://emailbydomain.com>

Auto manuals search

<http://auto.somanuals.com>

TV manuals search

<http://tv.somanuals.com>