

Freezer

Instructions for installation and use
IN F 140 UK



GB Uprigh Freezer

Instructions for installation and use



To maintain the EFFICIENCY and SAFETY of this appliance, we recommend:

- use only the MANUFACTURER Service
- use only ORIGINAL Spare Parts

Safety a good habit to get into

ATTENTION

Read your handbook carefully since it contains instructions which will ensure safe installation, use and maintenance of your appliance.

Your freezer is built to International standards (EN60) and has been awarded the European approval mark (IMQ) for compliance to UK electrical safety requirements. It also meets the EC standards on the prevention and elimination of radio interference (EC directive 87/308 - 02.06.89).

1. This appliance is designed to be used indoors and under no circumstances should it be installed outside.
2. The appliance should be used only by adults exclusively for storing foodstuffs in compliance with the instructions provided in the handbook. Under no circumstances should children be allowed to operate, or tamper with, this product.
3. For electrical safety, do not attempt to operate this appliance with wet hands or feet.
4. Do not operate this appliance connected to an extension lead. If a longer supply cable is required, this must be replaced with one of the same specifications in compliance with the current electrical regulations. This operation should be carried out by a qualified person. Ensure that the cable is not trapped or damaged during the installation.
5. Never pull the cable or the appliance to remove the plug from the socket.

6. Do not touch the internal cooling elements, especially if your hands are wet, since you could burn or hurt yourself. Do not eat ice cubes straight out of the freezer.

7. Before doing any cleaning, disconnect the appliance from the electricity (by pulling out the plug or turning off the general switch in your home).

8. Before disposing of your old appliance, remember to break or remove the lock as a safety measure to protect children who might lock themselves inside the appliance when playing.

9. If your appliance is not operating properly, before calling your after-sales service read the chapter on "Trouble Shooting" which might help you resolve the problem. Do not attempt to repair the fault by intervening on the internal components.

10. If the power supply cord must be replaced, please contact one of our Customer Service Centers. In some cases, the connections are made using special terminals and in others a special tool must be used to access the connections.

11. Do not use electric appliances inside the compartment for food storage, if these are not those recommended by the manufacturer.

12. At the end of the functional life of your appliance – containing cyclopentane gas in the insulation foam and perhaps gas R600a (isobutane) in the refrigeration circuit – the latter should be made safe before being sent to the dump. For this operation, please contact your dealer or the Local Organisation in charge of waste disposal.

Installation

To ensure that the appliance operates properly and to reduce energy consumption, it is important that the appliance is installed correctly.

Ventilation

The compressor and condenser generate heat and, therefore, need to be ventilated properly. Rooms with less than perfect ventilation are not very suited for installation of the appliance. Therefore, it should be installed in a room with an opening (window or French window) that provide the appropriate amount of air re-circulation. It is also important that the room not be too humid.

During installation, make sure not to cover or obstruct the grates that allow for proper ventilation of the appliance.

Away from Heat

Avoid positioning the appliance in a place where it is directly exposed to sunlight or near an oven, cook top or the like.

Electrical Connection and Earthing

Before proceeding with the electrical connection, make sure that the voltage indicated on the rating plate, located within the freezer, corresponds to the mains voltage in your home and that the socket is fitted with a standard earthing wire in accordance with safety standards for 46/90 systems. If the

socket is not fitted with an earthing wire, the manufacturer will not be held liability for any damages and or injuries arising out of the use of the appliance. Do not use multiple sockets or adapters.

Position the appliance in such a way that you can access the socket where it is plugged in.

Insufficient power?

The electrical socket must be able to handle the maximum power load of the appliance, which is indicated on the rating plate located at the bottom left next to the vegetable crisper.

Before making the electrical connection ...

After the appliance has been delivered, place it in the vertical upright position and wait at least 3 hours before inserting the plug into the socket in order to ensure that it functions properly.

For English Market only

The appliance is fitted with a continental 2-èin plug for factory testing. Before installation the plug should be cut off. The appliance is designed to be installed in a switched spur outlet fused at 13 Ampere. If the installation requires a 13 Ampere plug type to be fitted it should be conform to BSI 1363.

Electrical connection

Your appliance is now supplied with a 13 amp fused plug that can be plugged into a 13 amp socket for immediate use. Before using the appliance please read the instructions below.

WARNING - THIS APPLIANCE MUST BE EARTHED. THE FOLLOWING OPERATIONS SHOULD BE CARRIED OUT BY A QUALIFIED ELECTRICIAN.

Replacing the fuse:

When replacing a faulty fuse, a 13 amp ASTA approved fuse to BS 1362 should always be used, and the fuse cover re-fitted. If the fuse cover is lost, the plug must not be used until a replacement is obtained.

Replacement fuse covers:

If a replacement fuse cover is fitted, it must be of the correct colour as indicated by the coloured marking or the colour that is embossed in words on the base of the plug. Replacements can be obtained directly from your nearest Service Depot.

Removing the plug:

If your appliance has a non-rewireable moulded plug and you should wish to remove it to add a cable extension or to re-route the mains cable through partitions, units etc., please ensure that either:

- the plug is replaced by a fused 13 amp re-wireable plug bearing the BSI mark of approval

or:

- the mains cable is wired directly into a 13 amp cable outlet, controlled by a switch, (in compliance with BS 5733) which is accessible without moving the appliance.

Disposing of the plug:

Ensure that before disposing of the plug itself, you make the pins unusable so that it cannot be accidentally inserted into a socket. **Instructions for connecting cable to an alternative plug:**

Important: the wires in the mains lead are coloured in accordance with the following code:

Green & Yellow	- Earth
Blue	- Neutral
Brown	- Live

As the colours of the wires in the mains lead may not correspond with the coloured markings identifying the terminals in your plug, proceed as follows:

Connect Green & Yellow wire to terminal marked "E" or  or coloured Green or Green & Yellow.

Connect Brown wire to terminal marked "L" or coloured Red. Connect Blue wire to terminal marked "N" or coloured Black. If a 13 amp plug (BS 1363) is used it must be fitted with a 13 amp fuse. A 15 amp plug must be protected by a 15 amp fuse, either in the plug or adaptor or at the distribution board. If you are in any doubt about the electrical supply to your machine, consult a qualified electrician before use.

How to connect an alternative plug:

The wires in this mains lead are coloured in accordance with the following code:

BLUE	"NEUTRAL" ("N")
BROWN	"LIVE" ("L")
GREEN AND YELLOW	"EARTH" ("E")

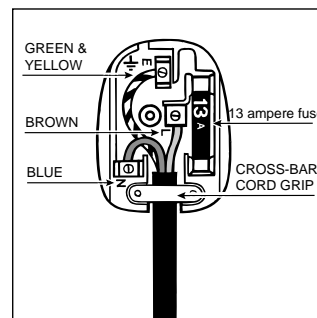

Disposing of the appliance:

When disposing of the appliance please remove the plug by cutting the mains cable as close as possible to the plug body and dispose of it as described above.

A closer look

A Thermostat

This regulates the temperature inside the appliance automatically. Turn the knob from setting **1** to **3** for increasingly colder temperatures.

To adjust the thermostat, use a coin to turn the knob.

B Green Light

When the light is on (move the switch to the right) this indicates that the appliance is connected to the mains. When the switch is moved to the left (green light covered), the appliance is disconnected from the mains.

C Yellow Light

When this light is on (move the switch to the left), the compressor will operate continuously to reach the lower temperatures necessary for freezing fresh foods quickly. By moving the switch to the right (yellow light covered) the freezer is operated by the thermostat.

D Red Light

This light goes on when the temperature inside the appliance is not sufficient to preserve foodstuffs.

E Ice tray compartment

F Compartment for freezing and storage

G Storage compartments

H Defrost water drain system

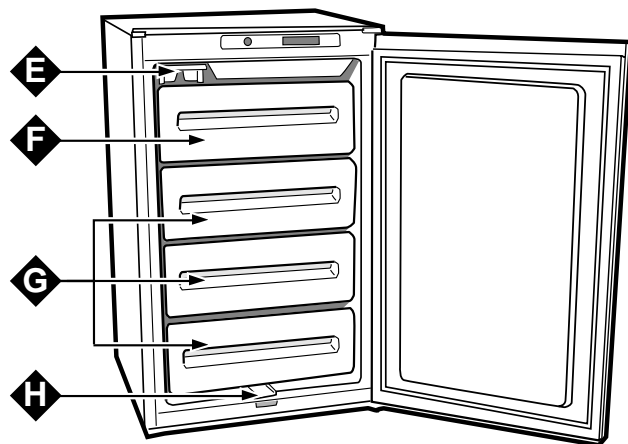
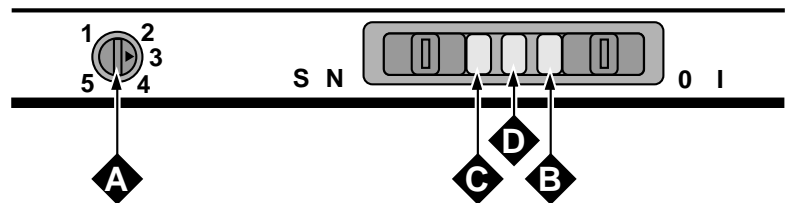

Setting up your appliance

ATTENTION

After transport stand the appliance upright and wait at least 3 hours before plugging the appliance into the mains to ensure proper performance.

Use these average temperature settings to ensure optimum performance and save energy.

Once the appliance has been connected to the mains, ensure that the green light is on and turn the yellow light on as well.

When the red light is off, turn off the yellow light: the appliance is now ready for use.

Using your freezer

Freezing

- Remember that you should never re-freeze products you have allowed to thaw, even if only partially: cook the food, then either eat (within 24 hours) or re-freeze it.

- In order to freeze fresh foods, the switch must be turned to the left (the yellow light will come on). Then introduce the food to be frozen into the top compartment, placing them - to the furthest extent possible - in direct contact with the cooling plate and away from any frozen food being stored.

Proper freezing depends on the speed at which food is frozen. For this reason, we recommend that the switch be turned to the freeze setting (the yellow light will come on) **24 hours before the food to be frozen is placed in the freezer. This operation is necessary for large quantities of food (up to the maximum capacity indicated on the data plate).**

- Do not open the freezer door during freezing.

- If a large amount of food is introduced for freezing at one time, the freezer temperature may momentarily increase inside the compartment (red light on). Since this is just a transient situation, the foods already stored in the freezer will not be harmed.

- After 24 hours have passed and the food has been frozen, turn the freezer switch back to the normal setting (the yellow light will turn off).

Important: Remember to carry out this last step in order to save energy.

- For the best conservation and defrosting, remember to freeze small portions; this will ensure rapid and uniform freezing. Mark the freezing date and description of the contents on the package, as shown in the table.

- In the case of power failure or breakdown, do not open the freezer door. This will help maintain the temperature inside the freezer ensuring that foods are conserved for at least 9-14 hours.

- Do not store full bottles in the freezer since they could explode when they freeze. (Remember that liquids increase in volume when frozen).

- Fill the ice trays so that they are no more than 3/4 full.

Preservation of Foodstuffs

To preserve frozen and deep-frozen foods well, never set the thermostat below 1, no matter what the room temperature is.

For room temperatures from 25°C to 27°C the knob should be set between 1 and 2 while for room temperatures of up to 32°C, set between 2 and 3.

The maximum storage times for frozen foods are indicated in the tables "Guide for using the freezer."

Always follow the instructions on the packages of deep frozen foods carefully and if there are no instructions never keep the food for more than 3 months from the date of purchase.

When buying deep-frozen foods, ensure that they have been stored at appropriate temperatures and that the wrapping is intact.

To keep the quality of the deep-frozen food unaltered, transfer it to special containers and then place it inside the storage compartment as soon as possible.

If a package shows signs of moisture and abnormal swelling, it has probably been stored at the wrong temperature and the contents have been spoiled.

Caring for your appliance

Before doing any cleaning, disconnect the appliance from the electricity (by pulling out the plug or turning off the general switch in your home).

Defrosting

WARNING: do not damage the refrigeration circuit. Do not use mechanical devices or other tools to speed up the defrosting process, unless they have been recommended by the manufacturer.

The frost should be removed from the walls of the appliance periodically.

Never use sharp metal objects to remove frost because they could pierce the cooling circuit and damage the freezer beyond repair.

Use the plastic scraper provided for this purpose. To defrost the appliance completely (this should be done once or twice a year), turn off the green light and leave the door open until the frost has completely thawed.

A defrost water collection system is situated at the bottom of this appliance as shown in figure 1.

To speed up defrosting, place one or more basins of warm water inside the appliance.

When defrosting, remove the frozen food from the appliance, wrap it in newspaper and store in a cool place. Since the rise in temperature will shorten the storage life of the food, it should be used as soon as possible.

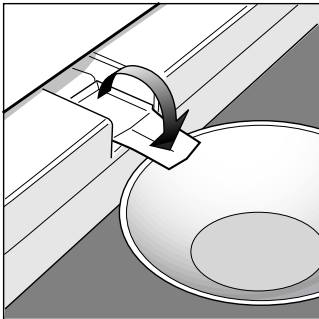

Fig. 1

Cleaning and maintenance

The refrigerator should be cleaned periodically with a solution of bicarbonate of soda and warm water. Never use abrasives, detergents or soaps; after washing, rinse with clean water and dry with care.

When these operations have been completed, turn on the green light and set the thermostat knob to the appropriate operating position.

After 2 or 3 hours, the appliance will once again be ready for preserving frozen and deep-frozen foods.

Guife for using the freezer

Meat and fish

Food	Wrapping	Tenderising (days)	Storage (months)	Thawing Time
Beef Roast	Tinfoil	2 / 3	9 / 10	Not required.
Lamb	Tinfoil	1 / 2	6	Not required.
Pork Roast	Tinfoil	1	6	Not required.
Veal Roast	Tinfoil	1	8	Not required.
Veal/Pork Chops	Each piece wrapped in cling wrap and then in tinfoil (4 to 6 slices)		6	Not required.
Veal/Lamb Cutlets	Each piece wrapped in cling wrap and then in tinfoil (4 to 6 slices)		6	Not required.
Minced Meat	In aluminium containers covered with cling wrap.	Freshly minced	2	Slowly in refrigerator.
Heart and Liver	Plastic Baggies		3	Not required.
Sausages	Cling Wrap or Tinfoil		2	As necessary.
Chicken and Turkey	Tinfoil	1 / 3	9	Very slowly in refrigerator.
Duck and Goose	Tinfoil	1 / 4	6	Very slowly in refrigerator.
Pheasant, Partridge and Wild Duck	Tinfoil	1 / 3	9	Very slowly in refrigerator.
Hare and Rabbit	Tinfoil	3 / 4	6	Very slowly in refrigerator.
Venison	Tinfoil or Cling Wrap	5 / 6	9	Very slowly in refrigerator.
Large Fish	Tinfoil or Cling Wrap		4 / 6	Very slowly in refrigerator.
Small Fish	Plastic Baggies		2 / 3	Not required.
Crustaceans	Plastic Baggies		3 / 6	Not required.
Shellfish	Store in salted water in aluminium containers or plastic containers.		3	Very slowly in refrigerator.
Boiled Fish	Tinfoil or Cling Wrap		12	In hot water.
Fried Fish	Plastic Baggies		4 / 6	Directly in pan.

Fruit and vegetable

Food	Preparation	Blanching Time	Wrapping	Storage (months)	Thawing Time
Apples and Pears	Peel and cut into slices.	2'	In Containers (cover with syrup)	12	In refrigerator very slowly.
Apricots, Peaches, Cherries and Plums	Peel and pit.	1' / 2'	In Containers (cover with syrup)	12	In refrigerator very slowly.
Strawberries Blackberries and Raspberries	Rinse and fry.		In Containers (cover with sugar)	10 / 12	In refrigerator very slowly.
Cooked Fruit	Cut, cook and strain.		In Containers (add 10% sugar)	12	In refrigerator very slowly.
Fruit Juice	Wash, cut and crush.		In Containers (sugar to taste)	10 / 12	In refrigerator very slowly.
Cauliflower	Remove leaves, cut head into small pieces and blanch in water and a little lemon juice.	2'	Plastic Baggies	12	Not required.
Cabbage and Brussel Sprouts	Wash and cut into small pieces.	1' / 2'	Plastic Baggies	10 / 12	At room temperature.
Peas	Shell and wash.	2'	Plastic Baggies	12	Not required.
French Beans	Wash and slice if required.	2	Plastic Baggies	10 / 12	Not required.
Carrots, Peppers and Turnips	Peel, wash and slice if necessary.	3' / 4'	Plastic Baggies	12	Not required.
Mushrooms and Asparagus	Wash, peel and cut up.	3' / 4'	Plastic Baggies or Containers	6	At room temperature.
Spinach	Wash and mince.	2'	Plastic Baggies	12	At room temperature.
Vegetable for Soups	Wash and cut up in small pieces.	3'	Plastic Baggies or Containers	6 / 7	Not required.
Various Foods	Preparation	Blanching Time	Wrapping	Storage (months)	Thawing time
Bread			Plastic Baggies	4	At room temperature and in the oven.
Cakes			Plastic Baggies	6	About 10 minutes at room temperature, cook at 100/200°C.
Cream			Plastic Containers	6	At room temperature or in refrigerator.
Butter			In original wrapping or tinfoil	6	In refrigerator.
Boiled Food or Vegetable Soup			Plastic or Glass Containers	3 / 6	At room temperature or in hot water.
Eggs			Freeze without shells in small containers	10	At room temperature or in refrigerator.

Trouble shooting

Green Light Off

Check that:

- there is no power failure
- the general switch or circuit breaker in your home is not disconnected

Red Light always On

Check that:

- the door is shut properly and that the door seals are not damaged;
- the thermostat temperature knob is on the correct setting;
- there is not too much frost on the inside walls.

Compressor operates continuously

Check that:

- the yellow light is not on (continuous operating function);
- the thermostat is in the correct position.

The appliance is noisy.

Check that:

- The appliance is perfectly level;
- The appliance has been installed between cabinets or other items that vibrate or are noisy.
- Remember that the refrigerating gas in the cooling circuit causes a slight bubbling sound, even when the compressor is not running (this is quite normal).

If after all the checks, the appliance still does not operate or the problem persists, call the nearest Service Centre and inform them of: the type of problem, the abbreviation of the model name (Mod.) and the relative numbers (S/N) written on the rating plate located within the freezer (see example in the figure below).

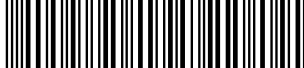
Mod. RG 2330		TI	Cod. 93139180000	S/N 704211801		
240 V	Hz	150 W	W	Fuse	Max 15	
Total	340	75		Freez. Capac	Class	
Gross Bruto Brut		Gross Bruto Brut	Net Util Utile	Gross Bruto Brut	Poder de Cong kg/24 h 4,0	Clase N
Compr. Syst.	R 134 a	Test P.S.-I.	Pressure HIGH-235	LOW 140		Classe
Kompr.	kg 0,090					
Made in Italy			13918			

Never call on unauthorized technicians and always refuse spare parts which are not originals.

Merloni Elettrodomestici

Viale Aristide Merloni 47

60044 Fabriano

Italy

Tel +39 0732 6611

Fax +39 0732 662501

www.merloni.com

Free Manuals Download Website

<http://myh66.com>

<http://usermanuals.us>

<http://www.somanuals.com>

<http://www.4manuals.cc>

<http://www.manual-lib.com>

<http://www.404manual.com>

<http://www.luxmanual.com>

<http://aubethermostatmanual.com>

Golf course search by state

<http://golfingnear.com>

Email search by domain

<http://emailbydomain.com>

Auto manuals search

<http://auto.somanuals.com>

TV manuals search

<http://tv.somanuals.com>