

OPERATOR'S MANUAL

INCLUDING: OPERATION, INSTALLATION & MAINTENANCE

6564X-X

6566X-X

66620

RELEASED: 8-28-91
REVISED: 10-11-01
(REV. K)

6" AIR MOTORS

6564X-X and 66620
4" STROKE

6566X-X
6" STROKE



READ THIS MANUAL CAREFULLY BEFORE INSTALLING,
OPERATING OR SERVICING THIS EQUIPMENT.

THIS MANUAL COVERS THE FOLLOWING MODELS

MODEL			
65643	65662	65665-2B	66620
65645	65665-B	65666	

SERVICE KITS

61355 for general repair of all 6" air motors.

GENERAL DESCRIPTION

The 6" air motor is a general purpose power unit and is used with many 2-ball, 4-ball and chop check pumps. It utilizes tie rod type construction for easy breakdown and it connects to the various lower ends via tie rods for easy operation. Consult pump model operator's manual for specific instructions. It is recommended that a muffler be connected to the exhaust port to reduce noise to acceptable OSHA standards.

Filtered and oiled air will allow the air motor to operate more efficiently and yield a longer life to operating parts and mechanisms. A filter capable of filtering particles larger than 50 microns should be used with an oiler. Keep the oiler supplied with a good grade of S.A.E. no. 90W non-detergent gear oil, set at a rate not to exceed 1 or 2 drops per minute.

NOTICE

DO NOT OPERATE AIR MOTOR ABOVE RECOMMENDED AIR PRESSURE OF 150 P.S.I. (10.3 BAR) OR 75 CYCLES PER MINUTE. Air motor may be rated differently in the next assembly. Check model plate.

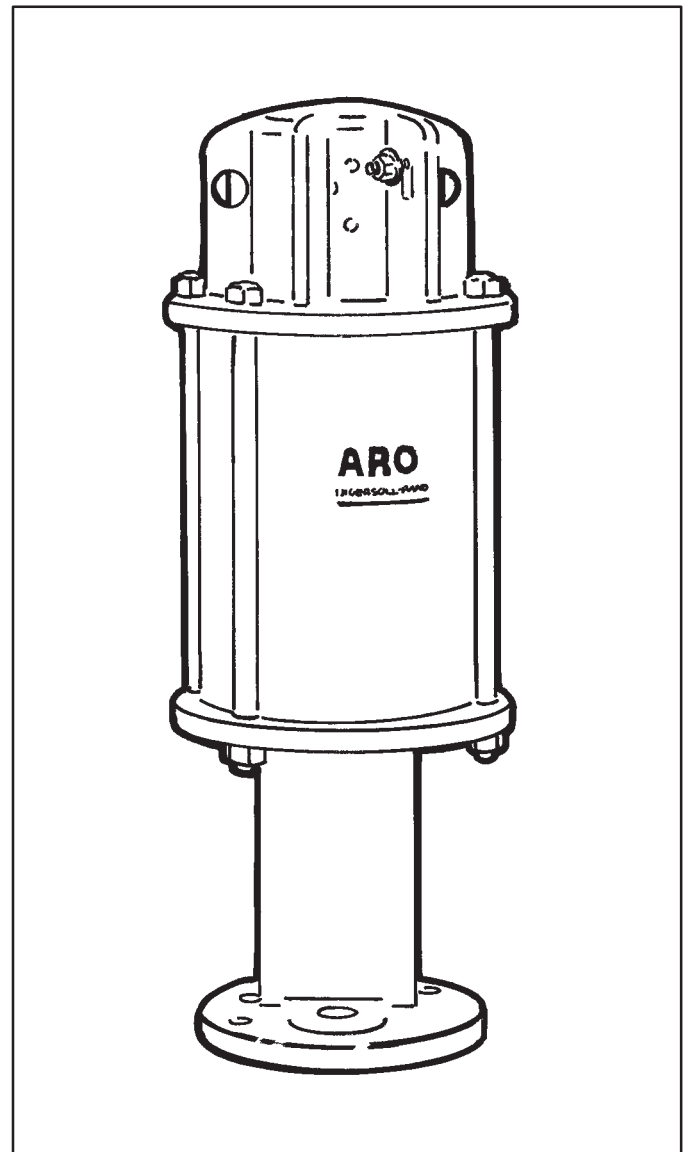

INGERSOLL-RAND COMPANY
P.O. BOX 151 • ONE ARO CENTER • BRYAN, OHIO 43506-0151
☎ (419) 636-4242 • FAX (419) 633-1674 ©2001 • PRINTED IN U.S.A.



AIR MOTOR PARTS LIST

✓ PARTS SO MARKED ARE INCLUDED IN 61355 SERVICE KIT.

REF.	DESCRIPTION (SIZE IN INCHES)	QTY	PART NO.
<input type="checkbox"/> 1	Machine Screw (#8 - 32 x 7/8")	4	Y136-90-S
<input type="checkbox"/> 2	Deflector	1	90409
	Deflector (model 65665-2B)	1	90409-1
<input type="checkbox"/> 3	Screw (#10 - 24 x 1/2")	6	95956827
✓ <input type="checkbox"/> 4	Machine Screw (#8 - 32 x 3/4")	8	Y19-89-S
✓ <input type="checkbox"/> 5	Washer	8	90084
<input type="checkbox"/> 6	Machine Screw (1/4" - 28 x 3/4")	2	Y119-49-C
	7 Lock Washer (1/4" i.d.)	2	Y14-416
<input type="checkbox"/> 8	Air Motor Cap	1	90078
	Air Motor Cap (model 65665-2B)	1	90078-5
<input type="checkbox"/> 9	Valve Guide	1	90488
✓ <input type="checkbox"/> 10	Gasket	1	90083-1
<input type="checkbox"/> 11	Valve Plate and Pin Assembly	1	65756
<input type="checkbox"/> 12	Insert Spring Assembly	1	65807
✓ <input type="checkbox"/> 13	Valve Insert	1	99202
✓ <input type="checkbox"/> 14	Valve Plate Gasket	1	90479
✓ <input type="checkbox"/> 15	"O" Ring (1/16" x 1-3/8" o.d.)	2	Y325-26
✓ <input type="checkbox"/> 16	Washer	1	91344
✓ <input type="checkbox"/> 17	"O" Ring (1/16" x 7/8" o.d.)	2	Y325-18
	18 Head Assembly	1	65890
	Head Assembly (model 65665-2B)	1	65890-3
✓ <input type="checkbox"/> 19	"U" Cup (3/16" x 1-3/8" o.d.)	1	Y186-51
✓ <input type="checkbox"/> 20	"O" Ring (1/8" x 6" o.d.)	2	Y325-256
✓ <input type="checkbox"/> 21	Machine Screw (#8 - 32 x 3/8")	4	Y136-85-S
	22 Adapter	1	90111
<input type="checkbox"/> 23	Piston Assembly	1	61419
<input type="checkbox"/> 24	"O" Ring (1.191" o.d.)	1	90085
	25 Nut	1	90112

REF.	DESCRIPTION (SIZE IN INCHES)	QTY	PART NO.
<input type="checkbox"/> 26	Valve Rod		See chart, page 4
<input type="checkbox"/> 27	Air Cylinder		See chart, page 4
	28 Tube		See chart, page 4
✓ <input type="checkbox"/> 29	"O" Ring		See chart, page 4
	30 Air Motor Base Assembly		See chart, page 4
✓ <input type="checkbox"/> 31	Valve Piston	1	92395
✓ <input type="checkbox"/> 32	Valve Plate Gasket	1	90482
<input type="checkbox"/> 33	Valve Plate	1	90480
✓ <input type="checkbox"/> 34	Pilot Insert	1	90487
<input type="checkbox"/> 35	Valve Guide	2	90481
✓ <input type="checkbox"/> 36	Washer	1	90105
<input type="checkbox"/> 37	Upper Gland	1	91006
✓ <input type="checkbox"/> 38	Seal	1	91007
✓ <input type="checkbox"/> 39	"O" Ring (.103" x 1.255" o.d.)	1	91207
<input type="checkbox"/> 40	Extension Rod	1	90080
	41 Ground Lug	1	93006
✓ <input type="checkbox"/> 42	Piston Adapter	1	92393
<input type="checkbox"/> 43	Lower Gland	1	90114
✓ <input type="checkbox"/> 44	Washer	1	91345
✓ <input type="checkbox"/> 45	"O" Ring (1/16" x 7/16" o.d.)	1	Y325-11
	46 Bolt		See chart, page 4
<input type="checkbox"/> 47	Retaining Ring		See chart, page 4
<input type="checkbox"/> 48	Guide Washer		See chart, page 4
✓ <input type="checkbox"/> 49	"U" Cup		See chart, page 4
	50 Nut		See chart, page 4
<input type="checkbox"/> 51	Washer		See chart, page 4
<input type="checkbox"/> 52	Piston Rod		See chart, page 4

"Smart Parts", Keep these items on hand in addition to the service kits for fast repair and reduction of downtime.

DISASSEMBLY OF AIR MOTOR

NOTE: ALL THREADS ARE RIGHT HAND.

- Force the (23) piston assembly up by pushing the (52) piston rod toward the top of the air motor.
- Remove the four (1) machine screws from the (2) deflector.
- Remove the (2) deflector.
- Remove the six (3) screws from the (8) air motor cap.
- Remove the (8) air motor cap and (10) gasket.
- Loosen the eight (4) machine screws (which hold the (11) valve plate and pin assembly, (9) valve guide, two (35) valve guides and the (33) valve plate) until the (9 and 35) valve guides can be removed by pulling upward (see figure 9).
- Remove the eight (4) machine screws and eight (5) washers from the 6" air motor by pressing outward with a small allen wrench (see figures 1 and 9).
- With a screwdriver, unhook the (12) insert spring assembly from the bottom of the (11) valve plate and pin assembly.
- Remove the (12) insert spring assembly from the pins in the top of the (11) valve plate and pin assembly.
- Remove the (11) valve plate and pin assembly and (33) valve plate by pulling upward. If they are stuck, tap the top edge lightly with a soft face hammer or screwdriver handle (do not tap with anything metallic).

- Remove the (13) valve insert and the (34) pilot insert.
- Remove the (32 and 14) gaskets.
- Remove the (12) insert spring assembly.
- Remove the two (6) machine screws and the two (7) lock washers from the (37) upper gland (see figure 9).
- Pull the (31) valve piston upward until the (37) upper gland has pulled out of its chamber.

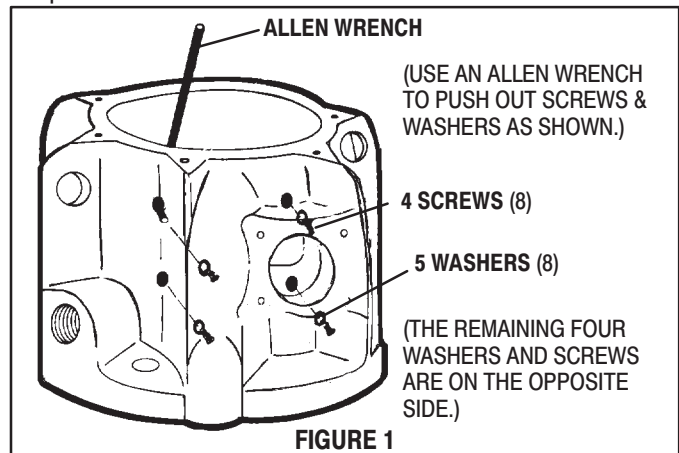

AIR MOTOR HEAD

PART NUMBERS LISTED BELOW AND ON PARTS LIST (OPPOSITE PAGE) ARE TYPICAL.

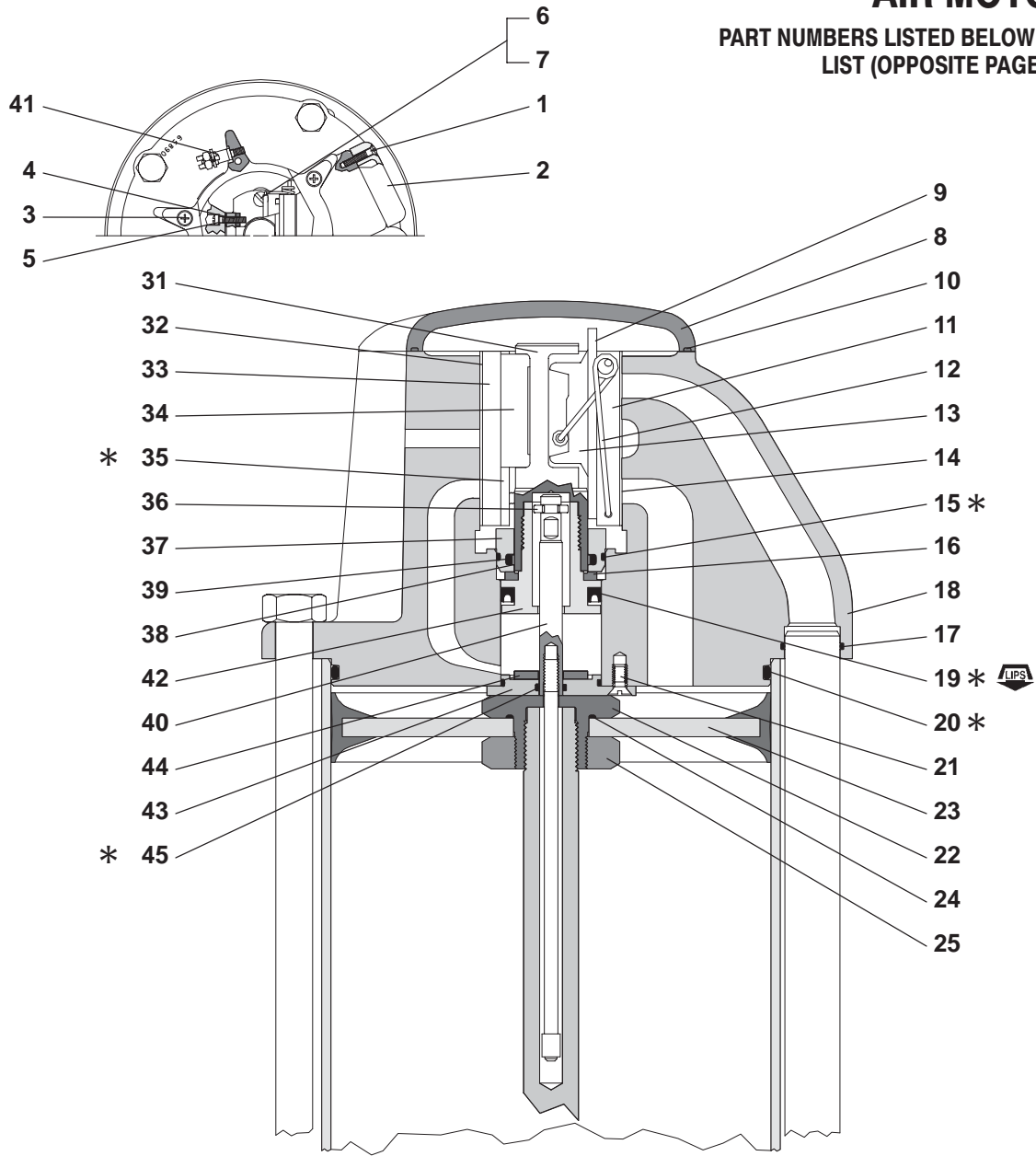

* NOTE: LUBRICATE WITH PARKER "O" RING LUBE (ARO P/N 36460).

FIGURE 2

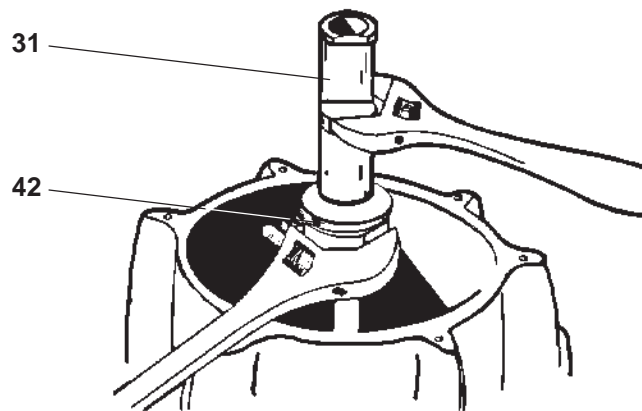

FIGURE 3

AIR MOTOR PARTS LIST

* AIR MOTOR MODEL NO.

- INDICATES WHERE PARTS ARE USED.
- MODELS NO LONGER ACTIVE, SHOWN FOR REFERENCE ONLY.

ITEM	DESCRIPTION	PART # (QTY)	65643	65645	65662	65665-B	65665-2B ●	65666	66620 ●
26 <input type="checkbox"/>	Valve Rod	90107-1							
	Valve Rod	90107-2							
27 <input type="checkbox"/>	Air Cylinder	90215-1							
	Air Cylinder	90215-2							
28	Tube	90485-1							
	Tube	90485-2							
29 ✓	"O" Ring	Y325-210							
30	Air Motor Base Assembly	65065							
	Air Motor Base Assembly	65065-2							
	Air Motor Base Assembly	65067							
	Air Motor Base Assembly ★	65868							
46	Bolt (1/2" - 20 x 10-1/4")	94046-1 (4)							
	Bolt (1/2" - 20 x 8-1/4")	94046-2 (4)							
47 <input type="checkbox"/>	Retaining Ring	Y147-131							
48 <input type="checkbox"/>	Guide Washer	73986							
49 ✓	"U" Cup	Y186-16							
50	Nut	Y11-8-C (4)							
51 <input type="checkbox"/>	Washer	90103							
52 <input type="checkbox"/>	Piston Rod	66628							
	Piston Rod	90082							
	Piston Rod	90108-1							
	Piston Rod	90108-2							

"Smart Parts", Keep these items on hand in addition to the service kits for fast repair and reduction of downtime.

* See model plate on (30) base for number.

INDICATES WHERE PARTS ARE USED.

✓ PARTS SO MARKED ARE ALSO INCLUDED IN 61355 SERVICE KIT.

NOTE: Base styles and lower packings may vary from that shown on the cover. Refer to model number in the chart above.

For simplification of ordering and stocking, a Y325-210 "O" ring and a Y186-16 "U" cup will be included in 61355 service kit. When repairing the motor, use only the one that is needed.

All of the service parts are the same for all motors except the lower piston rod packing.

★ On model 65662 air motors, a plate is mounted on the bottom of the (30) base. Therefore, the following parts are different and illustrated on page 8.

- 93310 Bushing
- 93311 Retainer
- 93312 Guide
- 93313 Plate (note the orientation of the plate with the air inlet)
- Y6-66-C Screw (4 req'd)
- Y14-616-C Lock Washer (4 req'd)



90350 INSTALLATION TOOL

NOTE: It is highly recommended that a 90350 installation tool be used. This will greatly ease installation of (42) piston adapter and piston valve and will reduce the chances of damage to the (19) "U" cup. A damaged (19) "U" cup can usually lead to air motor failure.

* NOTE: LUBRICATE WITH PARKER
"O" RING LUBE (ARO P/N 36460).

AIR MOTOR PISTON ROD AND BASE

SEE CHART ON OPPOSITE PAGE FOR EACH MODEL.

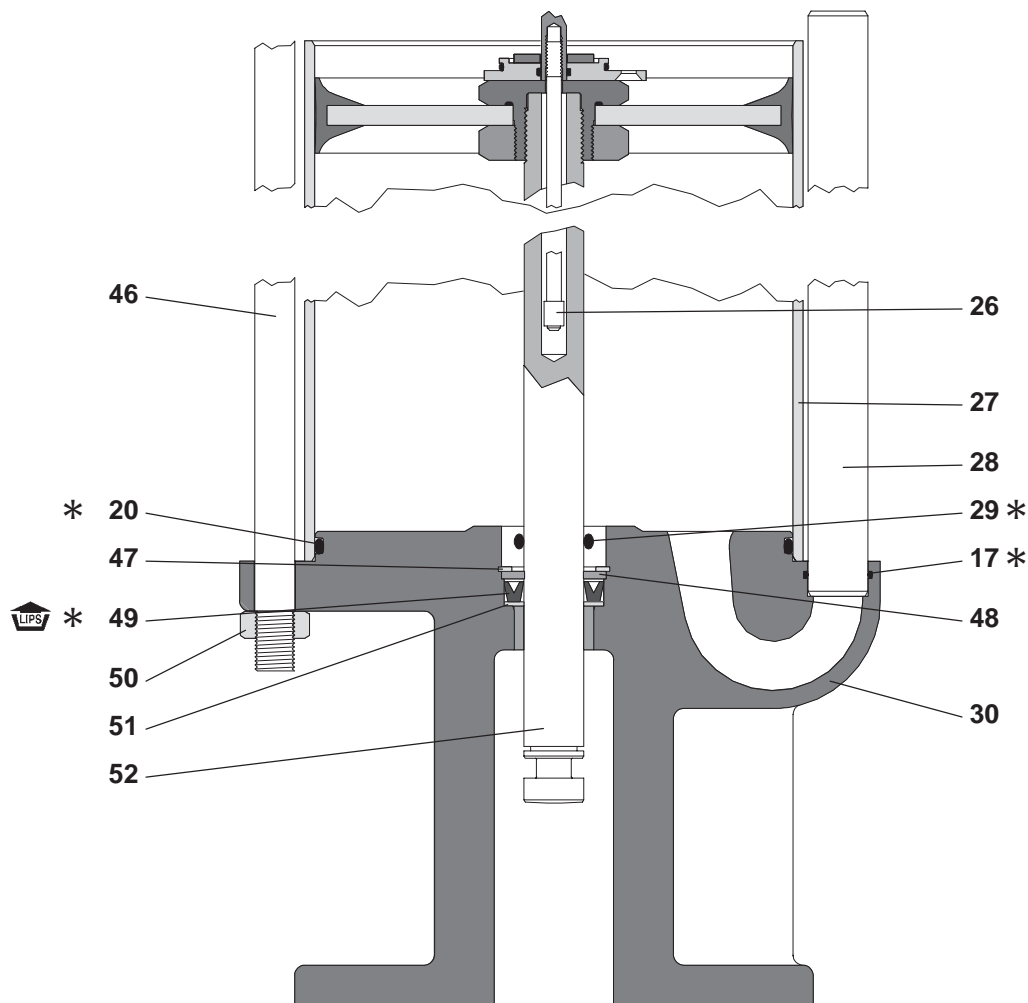

FIGURE 4

DISASSEMBLY OF AIR MOTOR (CONTINUED)

16. Remove the (37) upper gland.
 17. Remove the (38) seal and (39 and 15) "O" rings from the (37) upper gland (see figure 7).
 18. Disassemble the (31) valve piston from the (42) piston adapter (see figure 3).
 19. Remove the (31) valve piston.
 20. Pull the (42) piston adapter upward and grasp the (40) extension rod below the (42) piston adapter. Push the (42) piston adapter down on the (40) extension rod. Remove the (36) washer and (42) piston adapter.
 21. Remove the (16) washer and the (19) "U" cup from the (42) piston adapter.
 22. Remove the four (50) nuts from the four (46) bolts.
 23. Remove the four (46) bolts.
 24. Remove the (18) head assembly and place it on the workbench with the end that the (28) tube fits in "upward".
 25. Remove the (20) "O" ring from the (18) head assembly.
 26. Remove the four (21) machine screws from the (43) lower gland.
 27. Remove the (43) lower gland.
 28. Remove the (44) washer and (15 and 45) "O" rings from the (43) lower gland.
 29. Remove the (28) tube.
 30. Remove the (17) "O" ring from the (30) air motor base assembly and (18) head assembly.
 31. Pull upward on the (27) air cylinder until the (52) piston rod is separated from the (30) air motor base assembly. If the (52) piston rod does not separate from the (30) air motor base assembly, remove the (52) piston rod after removal of the (27) air cylinder.
 32. Remove the (20) "O" ring from the (30) air motor base assembly.
 33. Remove the (47) retaining ring, (48) guide washer, (49) "U" cup and (51) washer from the (30) air motor base assembly.
 34. Unscrew the (40) extension rod from the (26) valve rod by holding the (26) valve rod with adjustable type pliers and placing a wrench on the provided wrench flat at the top of (40) extension rod.
 35. Unscrew the (52) piston rod from (22) adapter, using wrench flats on (52) piston rod. Remove (26) valve rod from (52) piston rod.
- NOTE: Caution should be exercised so as not to mar or damage the finish on (40) extension rod or (52) piston rod.
36. Remove (25) nut, (23) piston assembly and (24) "O" ring from (22) adapter.

REASSEMBLY OF AIR MOTOR

NOTE: ALL THREADS ARE RIGHT HAND.

Apply grease to all "O" rings, "U" cups and other rubber goods when installing.

- Slip the (24) "O" ring on the (22) adapter, clean with solvent and apply Loctite 271 to the external threads of the (22) adapter. Assemble the (22) adapter and (25) nut to the (23) piston assembly and tighten to 160 - 180 ft lbs.
- Put the threaded end of the (26) valve rod thru the hole in the (22) adapter, with the "machined shoulder" end of the (26) valve rod on the threaded side of the (22) adapter.
- While holding the (26) valve rod below the threads with locking pliers, clean with solvent and apply Loctite 271 to the threads and attach the (40) extension rod, using the provided wrench flats.
- Place the "machined shoulder" end of the (26) valve rod into the hole in the end of the (52) piston rod and assemble (52) piston rod to (22) adapter, tightening using a wrench on flats provided.
- Thoroughly grease and install the (20) "O" ring in the (30) air motor base assembly.
- Grease and place the (51) washer and (49) "U" cup into the (30) air motor base assembly. Place the (48) guide washer and (47) retaining ring in the (30) air motor base assembly.
- Grease and install (15) "O" ring on the (43) lower gland.
- Grease the bore in the (18) head assembly and insert the (43) lower gland into the bore of the (18) head assembly, using a twisting motion.
- Align the screw holes in the (43) lower gland and (18) head assembly.
- Secure the (43) lower gland to the (18) head assembly using four (21) machine screws.
- Put the (52) piston rod thru the (49) "U" cup in the (30) air motor base assembly, being careful not to damage the "U" cup.
- Thoroughly grease the inside of the (27) air cylinder.

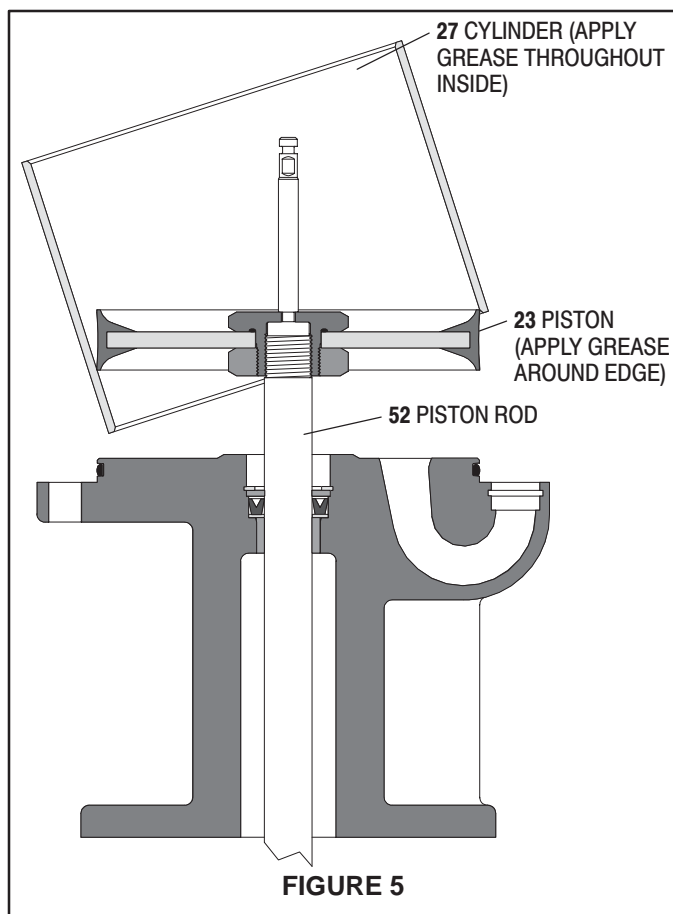

FIGURE 5

- Fill the area between the lips of (23) piston assembly with grease, then insert into the bottom of the (27) air cylinder (see figure 3).
- Push the (23) piston assembly to the top of the (27) air cylinder.
- Thoroughly grease and install the (45 and 20) "O" rings into the (18) head assembly.
- Thoroughly grease the two (17) "O" rings and install one in the (30) air motor base assembly. Install the other in the (18) head assembly.
- Press the (28) tube into the counterbored hole in the (30) air motor base assembly.
- Push the (40) extension rod thru the (45) "O" ring in the base of the (18) head assembly.
- Press the (18) head assembly down until the (27) air cylinder and (28) tube are seated in the (18) head assembly.
- Insert the four (46) bolts down thru the holes in the flanges of the (18) head assembly and the (30) air motor base assembly.
- Screw the four (50) nuts on the four (46) bolts. Alternately and evenly tighten the nuts.
- Thoroughly grease and install the (19) "U" cup in the (42) piston adapter, with the lips of the (19) "U" cup down toward the thick flange on the (42) piston adapter.
- Thoroughly grease and install the (39 and 15) "O" rings in the (37) upper gland.
- Bend the (38) seal in a heart shape and install in the (37) upper gland inside the (39) "O" ring (see figure 6).

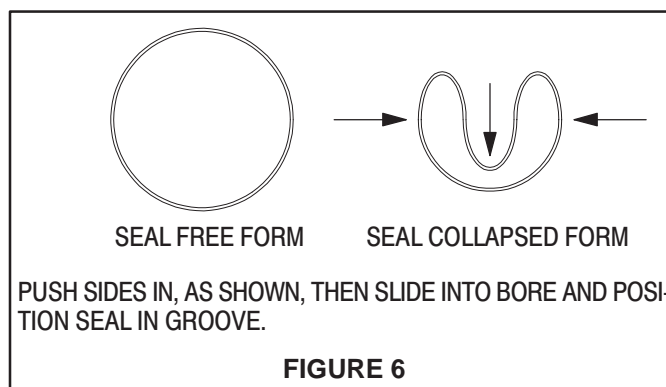

FIGURE 6

- Grease and carefully push the (31) valve piston into the (37) upper gland to size the (38) seal, then remove (see figure 7 below).

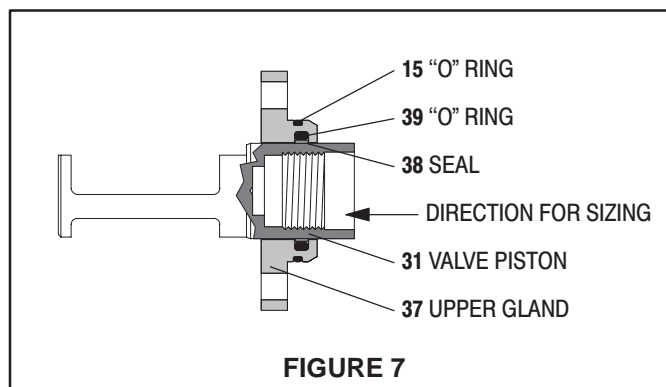

FIGURE 7

- Place the (44) washer over the (40) extension rod.
- Pull the (40) extension rod up and grasp with two fingers (see figure 8).
- Place the 90350 installation tool over the (40) extension rod, with the turned diameter down and the chamfer up.
- Fit the turned diameter of the 90350 installation tool into the bore in the bottom of the (18) head assembly.
- Place the (42) piston adapter down over the (40) extension rod, with the threads up.
- Insert the (36) washer into the groove in the top of the (40) extension rod.

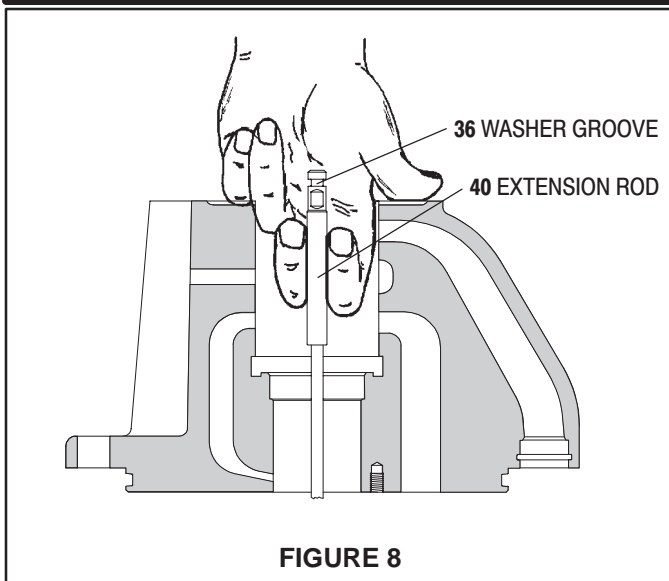

FIGURE 8

- 32. Pull the (42) piston adapter up around the (36) washer.
- 33. Place the (16) washer over the (40) extension rod and into the (42) piston adapter.
- 34. Clean with solvent and put Loctite 271 on the threads of the (31) valve piston. Screw the (31) valve piston into the (42) piston adapter and tighten (see figure 3).
- 35. Push the assembled (42) piston adapter and (31) valve piston down thru the 90350 installation tool until they bottom.
- 36. Remove the 90350 installation tool.
- 37. Install the (37) upper gland over the (31) valve piston and push down, being careful to retain the (38) seal in the "O" ring groove.
- 38. Align the two bolt holes and secure the (37) upper gland to the (18) head assembly with the two (6) machine screws and two (7) lock washers (see figure 9).
- 39. Insert the (12) insert spring assembly in the (18) head assembly, with the hooks down and the nylon roller toward the (31) valve piston (see figures 2 and 9).
- 40. Thoroughly grease and insert the (34) pilot insert, two (35) valve guides, (33) valve plate and (32) gasket into the (18) head assembly (see figure 9).
- 41. Thoroughly grease and insert the (13) valve insert into the (18) head assembly (see figure 2).

- 42. Thoroughly grease and insert the (14) gasket and the (11) valve plate and pin assembly between the (13) valve insert and the (18) head assembly, with the two pins in the (11) valve plate and pin assembly up (see figures 2 and 9).
- 43. Hook the round coils in the (12) insert spring assembly over the pins in the (11) valve plate and pin assembly (see figure 9).
- 44. Hook the bottoms of the (12) insert spring assembly into the holes on the side of the (11) valve plate and pin assembly.
- 45. Insert the (9) valve guide against the face of the (11) valve plate and pin assembly. The legs of the (9) valve guide should be down, with the leg having the threaded hole the farthest from the bottom toward the air inlet in the (18) head assembly.
- 46. Insert and tighten across corners of eight (4) machine screws and eight (5) washers (see figures 1 and 9).
- 47. Thoroughly grease and install the (10) gasket in the (8) air motor cap.
- 48. Place the (8) air motor cap on the (18) head assembly and secure with the six (3) screws (see figure 2).
- 49. Place the (2) deflector on exhaust port of the (18) head assembly, with the opening down, and secure with four (1) machine screws (see figure 2).

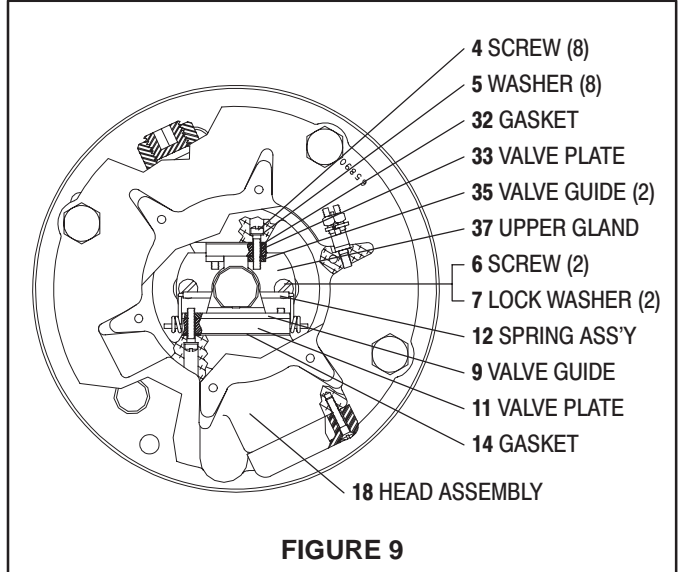

FIGURE 9

TROUBLE SHOOTING

PROBLEM
Air leakage out of main exhaust.

CAUSE
Worn (13) valve insert.

REMEDY
Replace (13) valve insert.

CAUSE
Worn (11) valve plate and pin assembly.

REMEDY
Replace (11) valve plate and pin assembly.

CAUSE
Damaged (23) piston assembly.

REMEDY
Replace (23) piston assembly.

PROBLEM
Continual air leakage out of bleeder hole in (18) head assembly.

CAUSE
Worn (15) "O" ring or (38) seal.

REMEDY
Replace (15) "O" ring and (38) seal.

PROBLEM
Air leakage around (52) piston rod.

CAUSE
Worn (49) "U" cup.

REMEDY
Replace (49) "U" cup.

65662 AIR MOTOR PISTON ROD & BASE

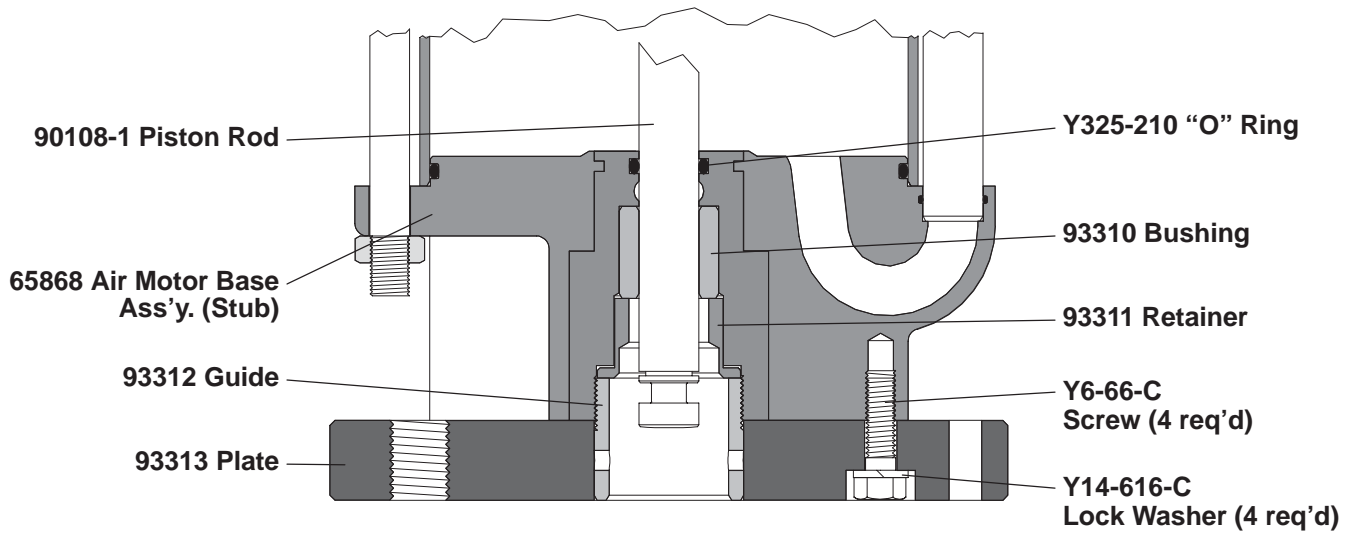

ITEM 52 PISTON ROD END VARIETY

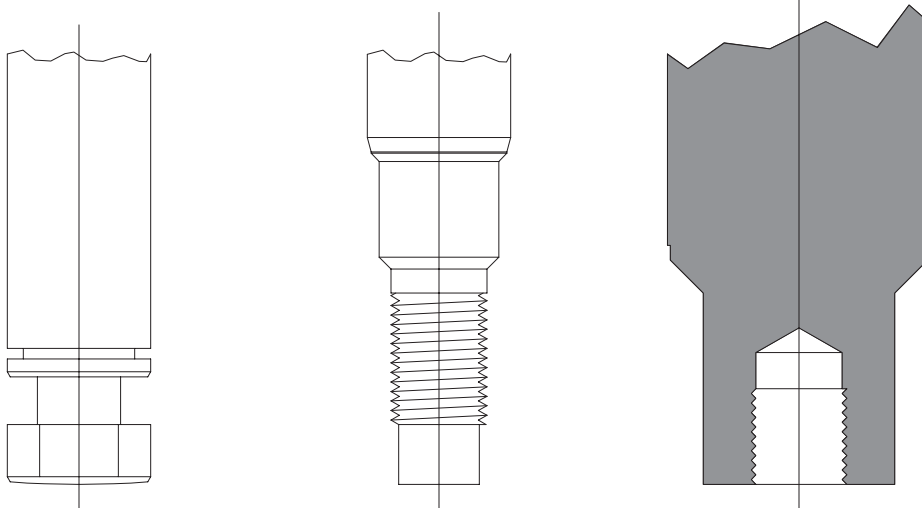

90108-1 Piston Rod
90108-2 Piston Rod

66628 Piston Rod

90082 Piston Rod

Free Manuals Download Website

<http://myh66.com>

<http://usermanuals.us>

<http://www.somanuals.com>

<http://www.4manuals.cc>

<http://www.manual-lib.com>

<http://www.404manual.com>

<http://www.luxmanual.com>

<http://aubethermostatmanual.com>

Golf course search by state

<http://golfingnear.com>

Email search by domain

<http://emailbydomain.com>

Auto manuals search

<http://auto.somanuals.com>

TV manuals search

<http://tv.somanuals.com>