

# OPERATOR'S MANUAL

612264-D

612274-D

INCLUDING:

OPERATION, INSTALLATION, & MAINTENANCE

ALSO INCLUDE SERVICE SHEETS; 6641X-X AIR MOTOR MANUAL,

640028 FOLLOWER PLATE (WITH 612274-D ONLY)

RELEASED: 4-8-82

REVISED: 07-3-93

IPP/PSE



## STATIONARY LUBRICATION PUMP

50:1  
RATIO

THIS MANUAL COVERS:

**612264-D**  
**400 LBS. DRUM**  
**WITH DRUM COVER**

**612274-D**  
**120 lbs. DRUM**  
**WITH DRUM COVER**  
AND 640028 FOLLOWER PLATE

### USE SERVICE KITS

637066 for 66410 Air Motor Ass'y.  
637021 for Lower End Pump Ass'y.

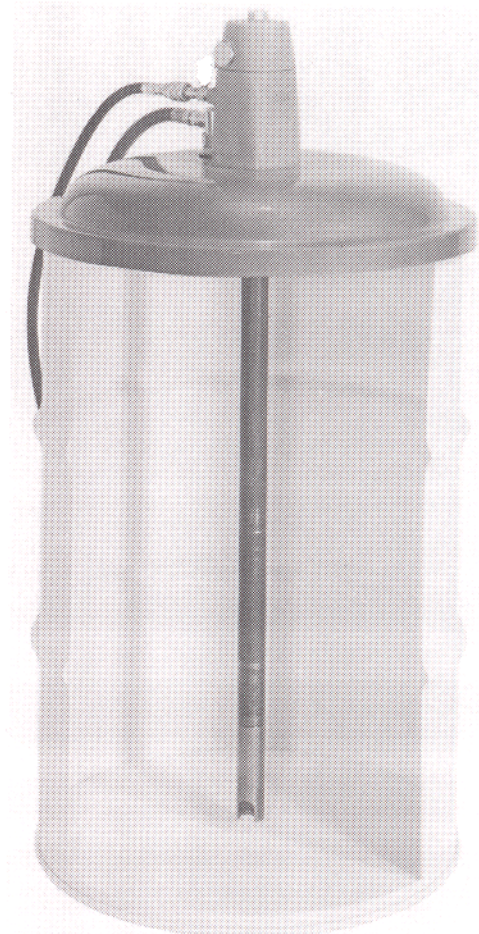

612264-D SHOWN  
(DRUM NOT INCLUDED)

### WARNING: HIGH PRESSURE DEVICE

IMPROPER USAGE OF EQUIPMENT COULD RESULT IN SERIOUS INJURY. THE POSSIBILITY OF INJECTION INTO THE FLESH IS A POTENTIAL HAZARD. NEVER ALLOW ANY PART OF THE HUMAN BODY TO COME IN FRONT OF OR IN DIRECT CONTACT WITH THE MATERIAL OUTLET.

AN INJECTION INJURY CAN BE SERIOUS! IF INJECTION SHOULD OCCUR, CONTACT A QUALIFIED PHYSICIAN FOR IMMEDIATE TREATMENT OF SUCH INJURIES.

**DO NOT EXCEED MAXIMUM WORKING PRESSURE OF 7500 PSI (517 BAR) AT 150 PSI (10 BAR) AIR PRESSURE**

THE ARO CORPORATION • ONE ARO CENTER • BRYAN, OHIO 43506-0151  
PH: (419) 636-4242 • FAX (419) 636-2115  
©1993 THE ARO CORPORATION • PRINTED IN U.S.A.



Part of worldwide Ingersoll-Rand



## LOWER PUMP END

The 50:1 ratio is an expression of the relationship between the effective air motor area and the effective lower pump end area. When 150 P.S.I. (10 bar) of air pressure is supplied to the air motor, the lower pump

end will develop a maximum of 7500 P.S.I. (517 bar) of fluid pressure (at no flow). As the fluid control is opened, the flow rate will increase as the air motor cycle rate increases to keep up with the demand.

## OPERATING AND SAFETY PRECAUTIONS

- Use ARO replacement parts to assure compatible pressure rating.
- HEED ALL WARNINGS AND CAUTIONS.
- CAUTION: The pump should not be used for the structural support of the piping system. Be certain system components are properly supported to prevent stress on the pump parts.
- Be sure material hoses and other components are able to withstand fluid pressures developed by this pump.
- Disconnect air line from pump when system sits idle for long periods of time.

**WARNING:** When using pump in a location where surrounding atmosphere is conducive to spontaneous combustion or when pumping, flushing or recirculating inflammable substances (e.g., paints, solvents, lacquers, etc.), failure to safeguard against static spark, open flame, heat and improper ventilation could result in explosion and/or fire causing severe personal injury or death and/or property damage.

- Safety precautions should include:
  - Use of static wire hoses.
  - Proper grounding of pump, dispensing valve or device, hoses, any object to which material is being transferred, and containers. After grounding, periodically check to verify continuity of electrical path to ground. Test with ohmmeter from each component (i.e., hoses, pump, clamp, container, spray gun, etc.) to ground to insure continuity. Ohm meter reading shown should be 10 ohms or less. Consult

local electric codes for specific grounding requirements.

- Submersion of outlet hose end, dispensing valve or device within material being dispensed whenever possible. (Avoid free streaming of material being dispensed.)
- Proper ventilation of area where pump and containers are located.
- Keeping inflammables away from heat, open flames and sparks.
- Keeping containers closed when not in use.
- Secure pump, connections and all contact points to avoid vibration and generation of contact or static spark.
- CAUTION: The chemical compatibility of the materials of which the wetted parts of the pump are constructed and the substance being pumped, flushed or recirculated with the pump must be verified. Chemical compatibility may change with temperature and concentration of chemical(s) within substance being pumped, flushed or recirculated. Consult ARO Form 8677-P, Fluid Compatibility Guide, for information on chemical compatibility. The Form 8677-P is available from ARO upon request.
- WARNING: DO NOT SERVICE OR CLEAN PUMP, OR REMOVE OUTLET HOSE AND/OR DISPENSING VALVE OR DEVICE, WHILE UNDER PRESSURE AS SERIOUS PERSONAL INJURY COULD RESULT. First disconnect air line, then relieve pressure from system by opening dispensing valve or device and/or carefully and slowly loosening and removing outlet hose or piping from pump.
- CAUTION: Do not allow pump to operate when out of material for long periods of time, this may cause unnecessary wear or damage to the pump.

## AIR AND LUBE REQUIREMENTS

- WARNING: DO NOT EXCEED MAXIMUM INLET AIR PRESSURE OF 150 PSI (6.9 BAR). OPERATING PUMP AT HIGHER PRESSURE MAY CAUSE PUMP DAMAGE AND/OR PERSONAL INJURY AND/OR PROPERTY DAMAGE.
- A Filter capable of filtering out particles larger than 50 microns should be used on the air supply. In most applications there is no lubrication required other than the "O" Ring lubricant which is applied during assembly or repair. When lubricated air is necessary, supply air lubricator with a good grade of SAE 90 wt. nondetergent oil and set lubricator to a rate not to exceed one drop per minute.

Filter-Regulator-Lubricator combination (F-R-L) Model 128121-300 is recommended for use with this pump. The capacity of the individual Filter-Regulator-Lubricator is adequate to provide clean (40 micron), regulated, and oiled air for the pump.

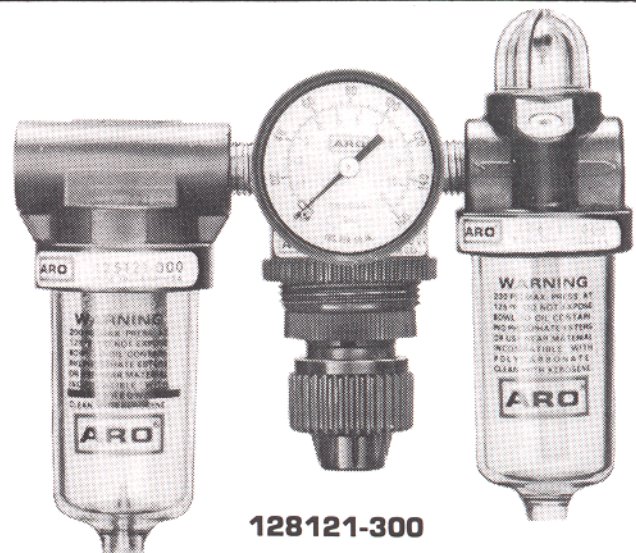

128121-300

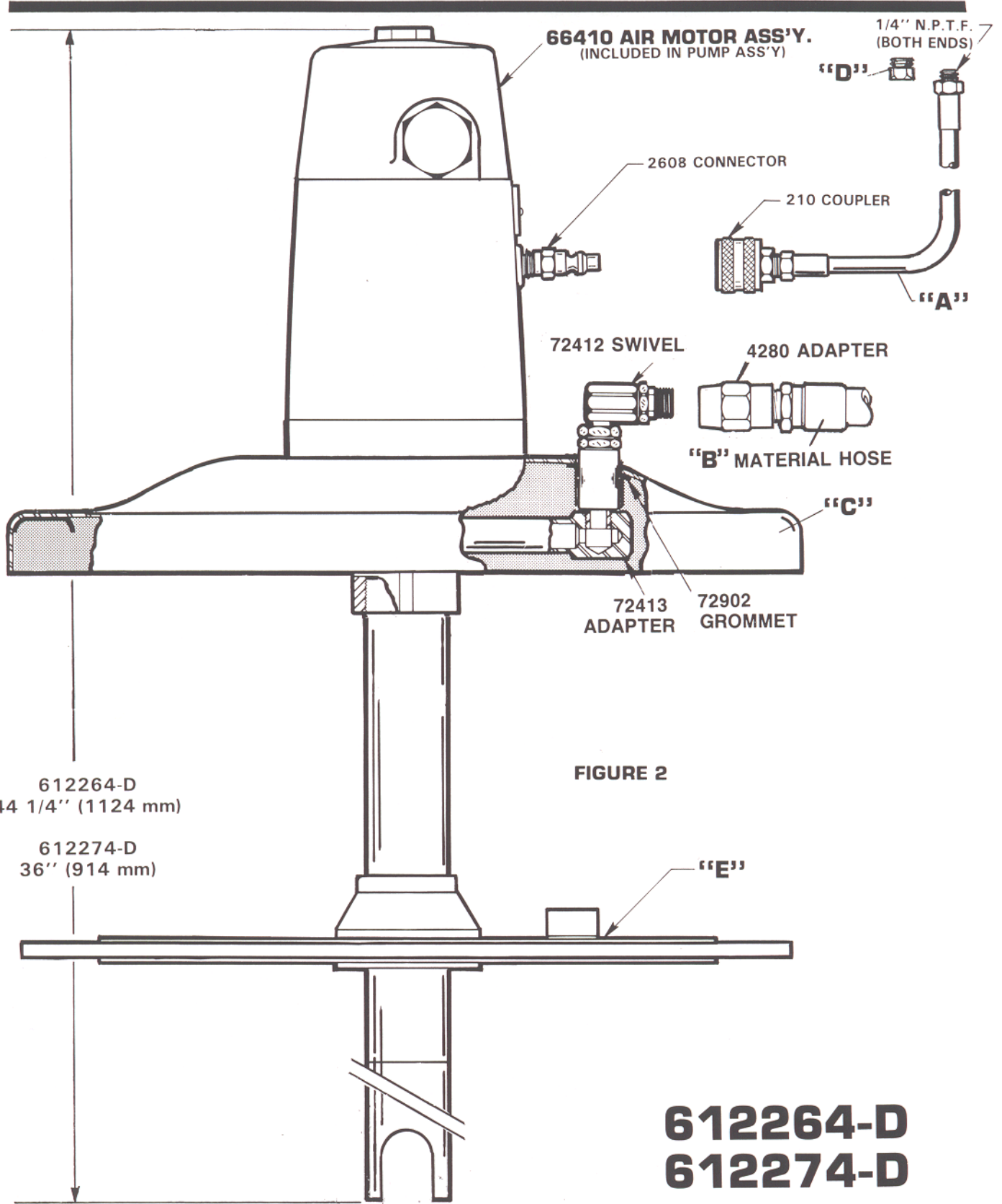

COMPONENTS	612264-D	612274-D
Basic Pump (See Page 5)	72654-D	72633-D
"A" Air Hose	622201-03	622201-05
"B" Mat'l Hose	624401-04	624401-08
"C" Cover	77422-1	72904
"D" Bushing		Y45-5-C
"E" Follower Plate		640028



## INSTALLATION

In remote installations, do not connect reel or control handle to material line until the following has been accomplished after mounting pump to desired location:

1. Before connecting pump, first blow out material line with air.
2. Connect fluid hose to pump material outlet.
3. Pump has been tested in kerosene and a small amount remains in pump end. Kerosene must be flushed from unit before placing into operation.
4. To flush system of kerosene, immerse material inlet hose from lower pump end into a 5 gallon pail of compatible solvent. Place the material outlet end of the outlet fluid hose in the pail of compatible solvent to complete the system.

5. Regulate air pressure from 30 to 50 P.S.I. (2-3 bar). Connect air supply to air motor inlet. Pump will start cycling. Let pump cycle slowly for a few minutes until kerosene is purged from pump.
6. Disconnect air supply. Remove pump from solvent.
7. Now connect pump and pump small amount of lubricant through line. This lubricant should be discarded.

The above procedure will clear any foreign material out of lines and insure line is not obstructed, thus aiding in trouble-free operation.

## OPERATING INSTRUCTIONS

Be sure material hose, lines and other components are able to withstand pressure developed by pump.

1. When pump is flushed of material and ready to operate, connect air line to the pump. Be certain that air supply does not exceed recommended maximum air pressure of 150 P.S.I. (10 bar).

**CAUTION:** Do not allow pump to operate when out of material.

2. Allow pump to cycle slowly and prime with material and bleed all air from system.

## MAINTENANCE

If the pump is to be inoperative for a lengthy period of time (a few hours) disconnect air and relieve all pressure from system.

Refer to Disassembly Procedures of air motor and lower pump end for correct breakdown.

Periodically flush pump with a solvent that is compatible with material being pumped.

Disassembly should be done on a clean work bench with clean cloths to keep parts clean.

If replacement parts are necessary, consult drawings containing parts for identification.

Before reassembling, lubricate parts where required. When assembling "O" rings or parts adjacent to "O" rings, care must be exercised to prevent damage to "O" rings and "O" ring groove surfaces.

## TROUBLE SHOOTING

No material at outlet  
(Pump continuously cycles)

Cause  
Solution

Empty material supply.  
Disconnect the air, replenish the material supply.

Cause  
Solution

Foreign matter is holding foot valve seats open in lower pump tube assembly.  
Remove lower pump tube assembly and clean valve seats.

Pump operates sluggishly, tends to stick when air is applied or control is opened.

Cause  
Solution

Air motor is dirty or lacks lubrication.  
Clean air motor.

Cause  
Solution

Insufficient air pressure or volume of air.  
Check air supply.

Air bypasses through exhaust port

Cause  
Solution

Foreign matter is holding air valve open or lacks lubrication.  
Consult factory for nearest Service Center.

Motor stalls

Cause  
Solution  
Cause  
Solution

Foreign matter in pump, hose, control valve or spray tip obstructing material flow.  
Check material supply hose and control valve or tip.  
Air not getting to pump.  
Check air supply.

# LOWER PUMP END PARTS LIST

NOTE: 66410 AIR MOTOR IS USED ON BOTH PUMP MODELS COVERED BELOW. SEE 6641X-X AIR MOTOR MANUAL FOR PARTS.

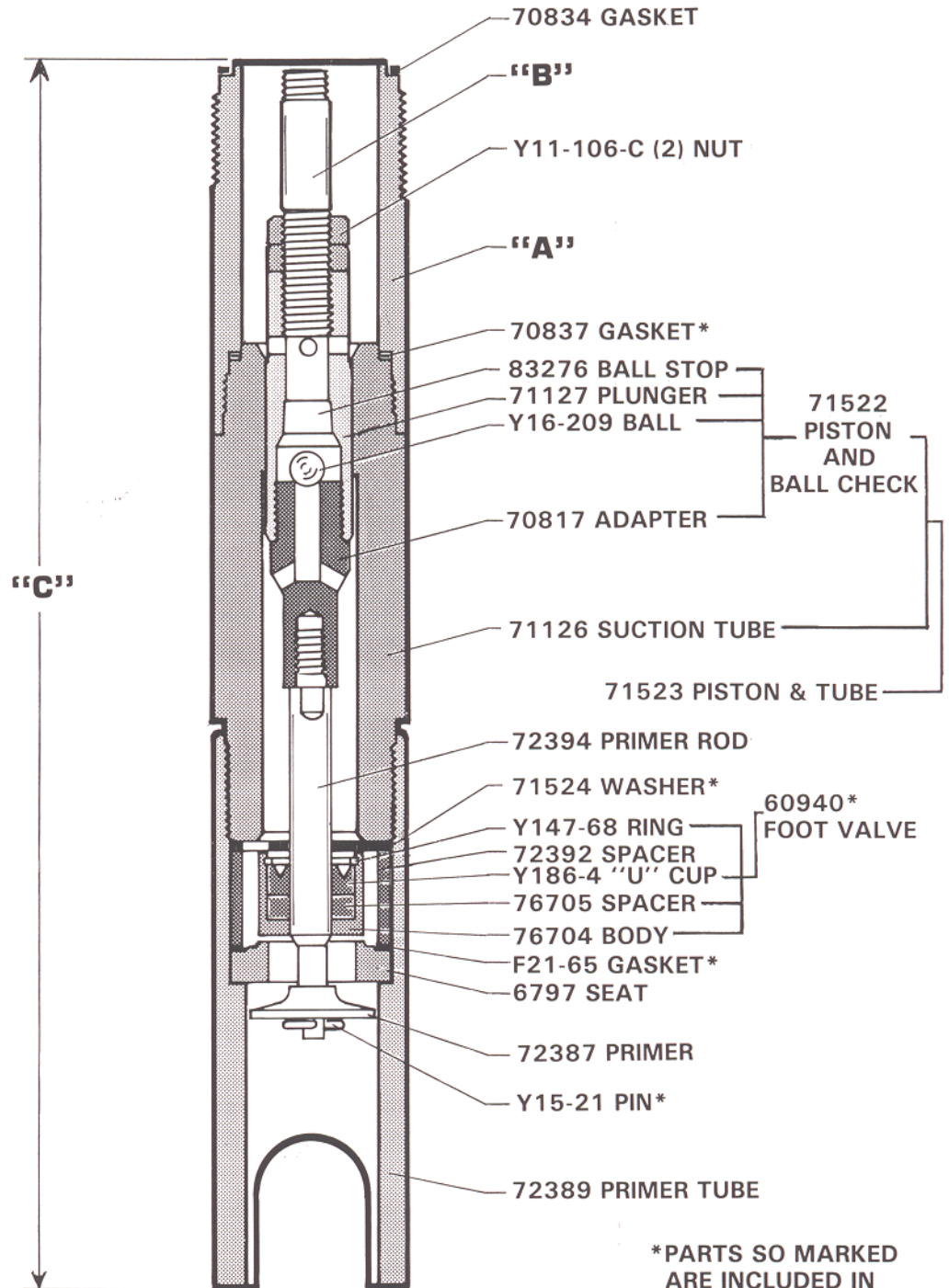

\*PARTS SO MARKED ARE INCLUDED IN 637021 SERVICE KIT

FIGURE 3

MODEL	TYPE	PUMP ASS'Y.	"A" TUBE	"B" ROD	OVERALL LENGTH "C"
612264-D	400 #COVER	72654-D	72642	72641	36"
612274-D	120 #COVER	72633-D	72690	72691	26"

### 72412 SWIVEL

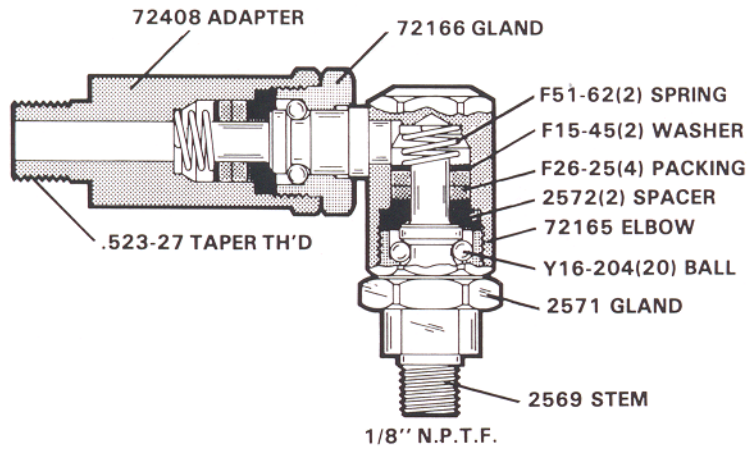

**FIGURE 4**



---

Part of worldwide Ingersoll-Rand

PN 97999-187

---

## Free Manuals Download Website

<http://myh66.com>

<http://usermanuals.us>

<http://www.somanuals.com>

<http://www.4manuals.cc>

<http://www.manual-lib.com>

<http://www.404manual.com>

<http://www.luxmanual.com>

<http://aubethermostatmanual.com>

Golf course search by state

<http://golfingnear.com>

Email search by domain

<http://emailbydomain.com>

Auto manuals search

<http://auto.somanuals.com>

TV manuals search

<http://tv.somanuals.com>