

OPERATOR'S MANUAL

650299

SPECIFICATIONS, SERVICE KITS, GENERAL INFORMATION

INCLUDE MANUALS: 650491-X PUMP (PN 97999-058), 651616-X TWO POST LIFT / RAM (PN 97999-613), 65940 AIR MANIFOLD (PN 97999-131) & S-636 GENERAL INFORMATION MANUAL (PN 97999-636).

RELEASED: 2-13-98
REVISED:
(REV.)

4-1/4" AIR MOTOR
12:1 RATIO
6" STROKE

650299
CARBON STEEL
PUMP SYSTEM

SERVICE KITS

- Use only genuine ARO® replacement parts to assure compatible pressure rating and longest service life.
- **29960** for repair of 27344-000 heavy duty regulator.
- **61268** for repair of 65465-B air motor.
- **104020** for repair of 25341-010 heavy duty filter.
- **104023** for repair of 26341-010 heavy duty lubricator.
- **104158** for repair of 127122-000 miniature regulator.
- **116772** for repair of E512LM valve.
- **637071-G43** for repair of 66243-G43 lower pump section.

SPECIFICATIONS

Model Series	650299
Type	Air Operated, Chop Check
Ratio	12:1
Air Motor	65465-B
Motor Diameter	4-1/4" (10.795 cm)
Stroke (Double Acting)	6" (15.24 cm)
Air Inlet	1/2" - 14 NPTF (f)
Lower Pump End Series	66243-G43
Material Outlet	1" - 11-1/2 NPTF - 1 (f)

PERFORMANCE

Air Inlet Pressure Range	0 - 150 PSI (0 - 10.3 bar)
Fluid Pressure Range	0 - 1800 PSI (0 - 124.1 bar)
Max. Rec'd Cycles / Minute	61.05
Displacement In ³ Per Cycle	12.5
Volume / Cycle	6.92 oz. (204.55 ml)
Cycles Per Gallon	18.5
Flow @ 60 Cycles / Minute	3.24 GPM (12.28 lpm)
Noise Level @ 60 Psi - 40 cpm	81.8 db(A) *

* The pump sound pressure level has been updated to an Equivalent Continuous Sound Level (L_{Aeq}) to meet the intent of ANSI S1. 13-1971, CAGI-PNEUROP S5.1 using four microphone locations.

IMPORTANT

This is one of the ten documents which support the system. Replacement copies of these forms are available upon request.

- 650299 PUMP SYSTEM OPERATOR'S MANUAL
- 1251X1-XXX MINIATURE F-R-L OPERATOR'S MANUAL
- 253XX-X HEAVY-DUTY F-R-L OPERATOR'S MANUAL
- 650491-X EXTRUSION PUMP OPERATOR'S MANUAL
- 651616-X TWO POST LIFT / RAM OPERATOR'S MANUAL
- 6544X-X 4-1/4" AIR MOTOR OPERATOR'S MANUAL
- 65940 AIR MANIFOLD ASSEMBLY OPERATOR'S MANUAL
- 66243-X LOWER PUMP END OPERATOR'S MANUAL
- GENERAL INFORMATION - AIR OPERATED LIFTS AND RAMS
- GENERAL INFORMATION - AIR OPERATED PUMPING SYSTEMS
- GENERAL INFORMATION - PNEUMATIC VALVES

PUMP DATA

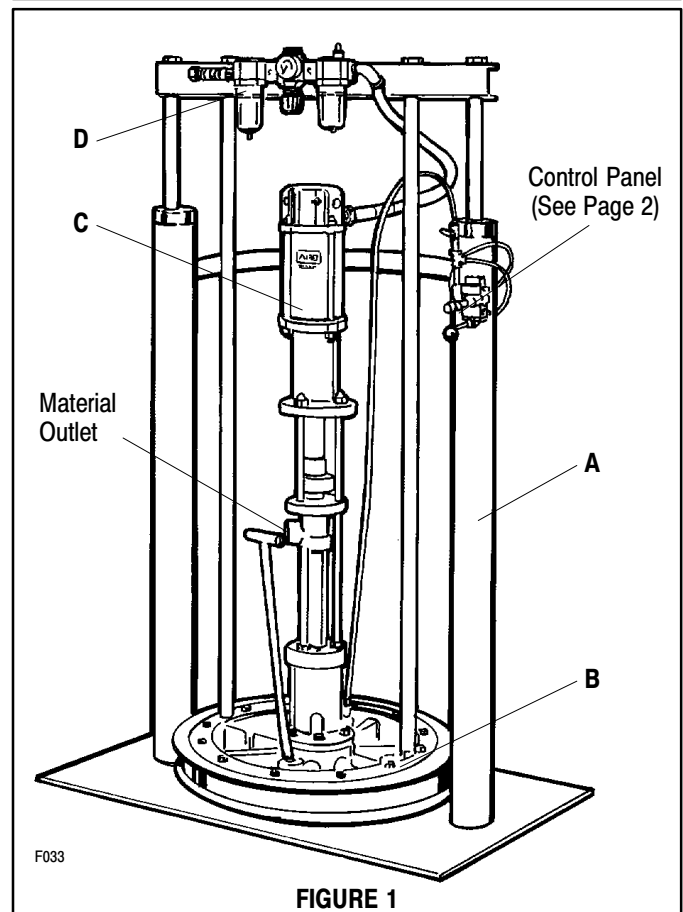

MAJOR COMPONENTS

ITEM	DESCRIPTION (Size in Inches)	QTY	PART NO.
A	Two Post Ram	(1)	67081
B	Follower Plate	(1)	66516-1
C	Basic Pump Assembly	(1)	650491-G43
D	Air Manifold Assembly	(1)	65940

GENERAL DESCRIPTION

⚠ WARNING DO NOT EXCEED MAXIMUM OPERATING PRESSURE OF 1,800 P.S.I. (124.1 BAR) AT 150 P.S.I. (10.3 BAR) AIR INLET PRESSURE.

⚠ WARNING READ THE GENERAL INFORMATION MANUAL INCLUDED FOR OPERATING AND SAFETY PRECAUTIONS AND OTHER IMPORTANT INFORMATION.



INGERSOLL-RAND COMPANY
ONE ARO CENTER • BRYAN, OHIO 43506-0151
☎ (419) 636-4242 • FAX (419) 633-1674 ©1998 • PRINTED IN U.S.A.

INGERSOLL-RAND
FLUID PRODUCTS

GENERAL DESCRIPTION

ARO Systems are totally enclosed, sealing the material in the system from air and moisture, preventing premature cure-out of the material. This allows for either continuous or intermittent use of the system and reduces the need for daily system clean-up. Built-in lift capability allows for quick drum changeover and easy lifting of pump assembly from container.

INSTALLATION

The 650299 chop-check dispensing system comes completely assembled. Remove unit from crate and place on a level surface. Install material hose and dispensing device as required. When the following instructions are observed, heavy paste materials can be pumped directly from their original 55 gallon drum without air inclusion or excessive waste. The follower plate creates an air tight seal as well as clean-wiping action in its progressive downward movement into the drum.

OPERATING INSTRUCTIONS

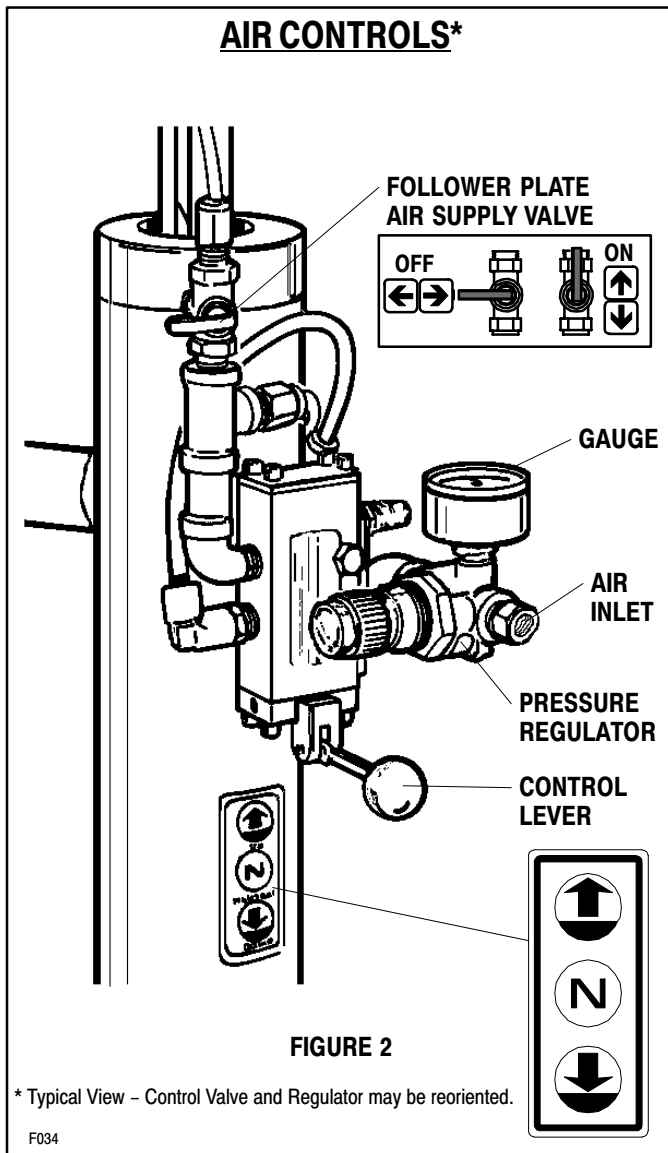

4. Raise the lift / ram high enough to clear the height of the drum. Stop the lift / ram's upward travel by moving the control valve lever to the "neutral" (center) position.

REFER TO PAGE 3:

1. Once the lift / ram assembly and pump are in the "up" position, place and center an opened 55 gallon drum of material on the lift / ram base.
2. Lubricate lower follower wiper plate seal with grease. NOTE: Make certain the grease is compatible with the material being dispensed. This ensures a smooth fit into the drum as well as prevents curing type compounds from bonding to seal.
3. Check vent plug on follower plate to be sure it easily threads in and out. It is recommended to lubricate the threads of the plug to help prevent possible set up of compound at this point. See 651616-X Two Post Lift / Ram Operator's Manual.

TO LOWER LIFT:

⚠ WARNING PINCH HAZARD. Follower can descend quickly causing injury. Keep hands clear when aligning with container.

NOTE: Be certain the follower plate vent plug has been removed so that the air trapped between the follower and the material is allowed to escape from this vent. Captured air between the follower plate and drum will escape.

NOTE: The lift / ram may hesitate momentarily before starting downward. The air pressure inside the post air chamber must decrease before it will begin to descend.

1. Shift the control valve lever to the "down" position and proceed to lower the pump.
2. Replace the vent plug once the material begins to ooze from the vent opening.
3. The unit is now ready for operation. Adjust the air pressure on the pump filter / regulator (turn pump regulator knob clockwise) until the pump begins to cycle.
4. Trigger gun to prime pump with material.

TO RAISE LIFT, (NORMAL OPERATION):

1. Adjust the follower plate air valve pressure up to approximately 8 psig (.55 bar). DO NOT OVERPRESSURIZE THE DRUM to avoid damage. NOTE: Air from this valve will only pass when the control lever is in the "up" position.
2. Shift the control valve lever to the "up" position.
3. Raise the lift / ram high enough to clear the height of the drum. Stop the lift / ram's upward travel by moving the control valve lever to the "neutral" (center) position.
4. Place and center a new drum into position. Remove cover.

TO RAISE LIFT, (THE FIRST TIME):

1. Take note of the pump / drum clearance above. Be certain the lift / ram is clear of any objects above. Also refer to "Operating and Safety Precautions" found in "Lifts and Rams General Information Manual" (pn 97999-635).
2. Connect the air supply (160 PSI MAX.) to the air inlet. Adjust air pressure on lift / ram pressure regulator (turn knob clockwise) to 20 p.s.i. (1.4 bar).
3. Shift the control valve lever to the "up" position.

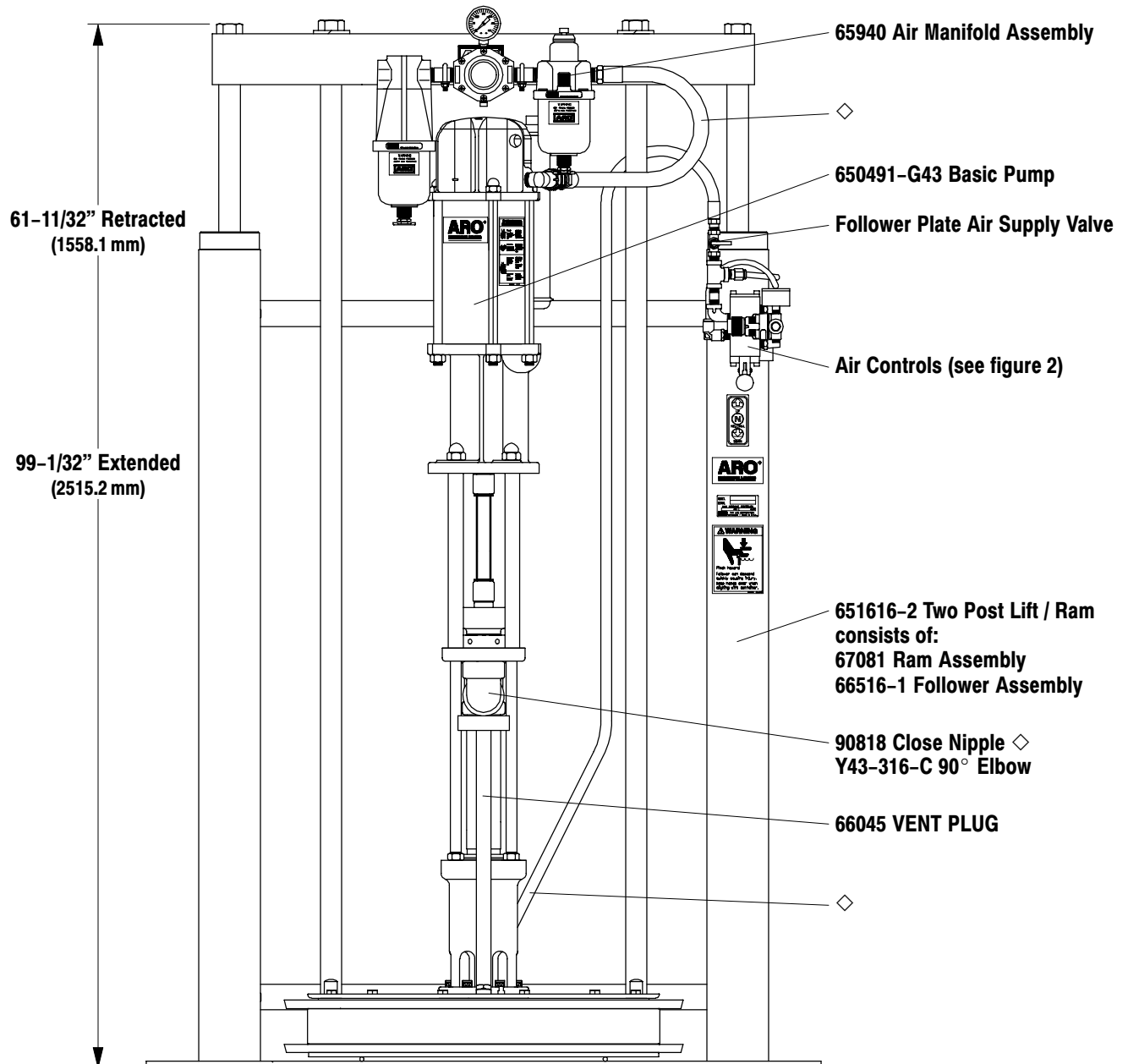
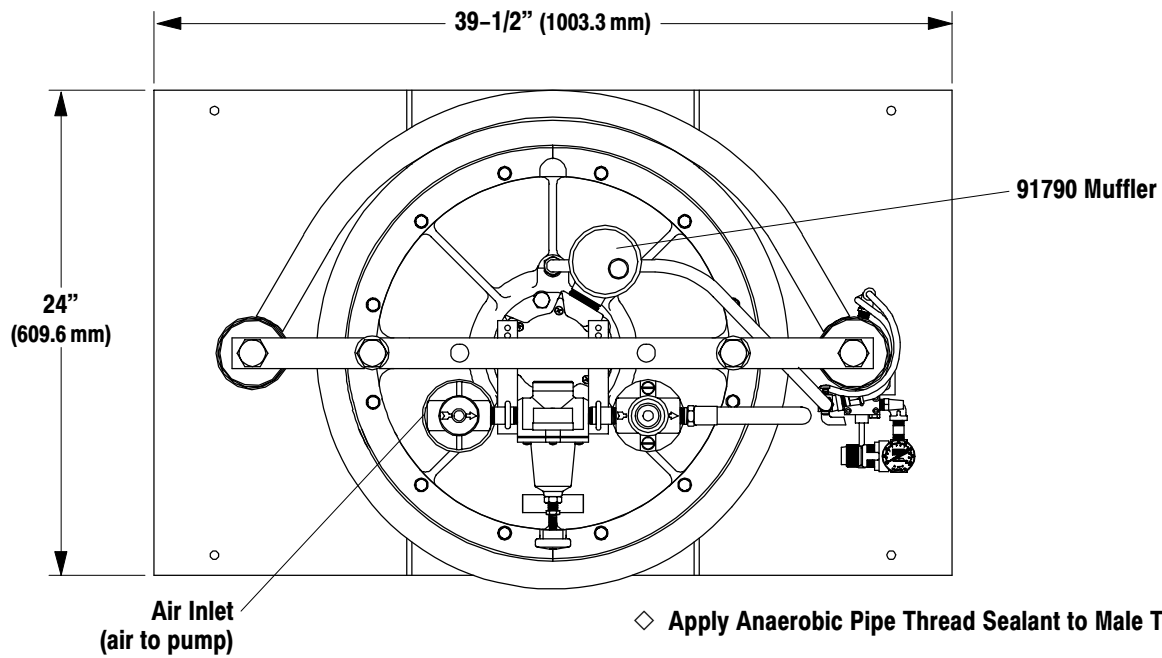

F035

FIGURE 3

Free Manuals Download Website

<http://myh66.com>

<http://usermanuals.us>

<http://www.somanuals.com>

<http://www.4manuals.cc>

<http://www.manual-lib.com>

<http://www.404manual.com>

<http://www.luxmanual.com>

<http://aubethermostatmanual.com>

Golf course search by state

<http://golfingnear.com>

Email search by domain

<http://emailbydomain.com>

Auto manuals search

<http://auto.somanuals.com>

TV manuals search

<http://tv.somanuals.com>