

## 2" DIAPHRAGM PUMP 1:1 RATIO (METALLIC)

---

**IMPORTANT: READ THIS MANUAL CAREFULLY BEFORE INSTALLING,  
OPERATING OR SERVICING THIS EQUIPMENT.**

---

---

### PUMP DATA

---

MODEL- 650749

TYPE - Air Operated Double Diaphragm (No Fluorocarbon)

MAT'L - Aluminum center body, stainless steel manifolds and  
fluid caps, stainless steel seats, EPR balls and  
diaphragms

WEIGHT - (ALUMINUM CTR-BODY) 79 lbs

MAXIMUM AIR INLET PRESSURE - 120 psi (8 bar)

MAXIMUM FLOW (with flooded inlet) - 0-135 gpm

MAXIMUM PARTICLE SIZE - 1/4" dia.

AIR INLET SIZE - 1/2"NPT

FLUID INLET - 2"NPT

FLUID OUTLET - 2"NPT

See page 8 for dimensional data.

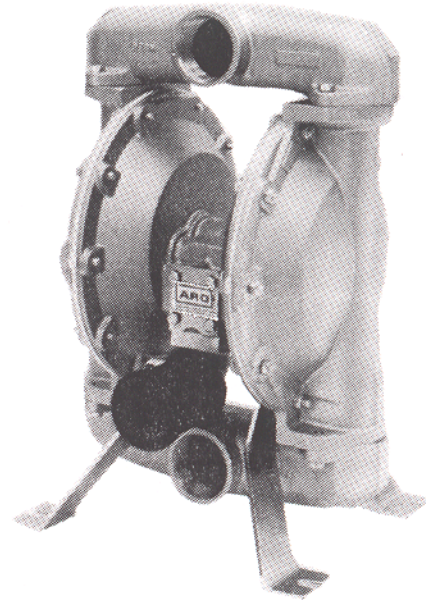

MODEL 650749

---

## OPERATING AND SAFETY PRECAUTIONS FOR DIAPHRAGM PUMPS

---

- HEED ALL WARNINGS AND CAUTIONS.
- Use original manufacturers' replacement parts to assure compatible pressure rating.
- **WARNING:** DO NOT EXCEED MAXIMUM INLET AIR PRESSURE OF 120 PSI (8 BAR). OPERATING PUMP AT HIGHER PRESSURE MAY CAUSE PUMP DAMAGE AND/OR PERSONAL INJURY AND/OR PROPERTY DAMAGE.
- **WARNING:** WHEN USING PUMP IN A LOCATION WHERE SURROUNDING ATMOSPHERE IS CONDUCIVE TO SPONTANEOUS COMBUSTION OR WHEN PUMPING, FLUSHING OR RECIRCULATING INFLAMMABLE SUBSTANCES (E.G., PAINTS, SOLVENTS, LACQUERS, ETC.), FAILURE TO SAFEGUARD AGAINST STATIC SPARK, OPEN FLAME, HEAT AND IMPROPER VENTILATION COULD RESULT IN EXPLOSION AND/OR FIRE CAUSING SEVERE PERSONAL INJURY OR DEATH AND/OR PROPERTY DAMAGE.
- Safety precautions should include:
  - Use of static wire hoses.
  - Proper grounding of pump (at clamps), dispensing valve or device, hoses, any object to which material is being transferred, and containers. After grounding, periodically check to verify continuity of electrical path to ground. Test with ohmmeter from each components (i.e., hoses, pump, clamps, container, spray gun, etc.) to ground to insure continuity. Ohmmeter reading shown should be 10 ohms or less. Consult local electric codes for specific grounding requirements.
  - Submersion of outlet hose end, dispensing valve or device within material being dispensed whenever possible. (Avoid free streaming of material being dispensed.)
  - Piping exhaust to a safe remote location when pumping hazardous or inflammable substances since the material being pumped is exhausted with the air if the diaphragm ruptures. Use a grounded 3/4" min. I.D. hose between pump and muffler.
  - Proper ventilation of area where pump and containers are located.
  - Keeping inflammables away from heat, open flames and sparks.
  - Keeping containers closed when not in use.
  - Secure pump, connections and all contact points to avoid vibration and generation of contact or static spark.
  - Be sure material hoses and other components are able to withstand fluid pressures developed by this pump. Check all hoses for damage or wear. Be certain dispensing device is clean and in proper working condition.
  - Disconnect air line from pump when system sits idle for long periods of time.
  - Suction and discharge connections should be flexible connections (such as hose), not rigid piped, and should be compatible with the substance being pumped.
- **WARNING:** DO NOT SERVICE OR CLEAN PUMP, HOSES OR DISPENSING VALVE WHILE THE SYSTEM IS PRESSURIZED AS SERIOUS PERSONAL INJURY COULD RESULT. First disconnect air line, then relieve pressure from system by opening dispensing valve or device and/or carefully and slowly loosening and removing outlet hose or piping from pump.
- **WARNING:** DO NOT USE III.-TRICHLOROETHANE, METHYLENE CHLORIDE OR OTHER HALOGENATED HYDROCARBON SOLVENTS IN THIS PUMP. THE PUMP CONTAINS ALUMINUM WHICH MAY REACT WITH THE SOLVENT AND EXPLODE. MATERIALS CONTAINING HALOGENATED HYDROCARBON SOLVENTS SHOULD NOT BE USED WITH THIS EQUIPMENT. CONSULT YOUR MATERIAL SUPPLIER FOR COMPATIBILITY WITH ALUMINUM.
- **CAUTION:** Verify the chemical compatibility of the pump wetted parts and the substance being pumped, flushed or recirculated. Chemical compatibility may change with temperature and concentration of the chemical(s) within the substance being pumped, flushed, or recirculated. Consult engineering guide for information on chemical compatibility.
- BE CERTAIN ALL THE OPERATORS OF THIS EQUIPMENT HAVE BEEN TRAINED FOR SAFE WORKING PRACTICES, UNDERSTAND ITS LIMITATIONS, AND WEAR SAFETY GOGGLES/EQUIPMENT WHEN REQUIRED.
- **CAUTION:** The pump should not be used for the structural support of the piping system. Be certain system components are properly supported to prevent stress on the pump parts.
- **CAUTION:** Do not allow pump to operate when out of material for long periods of time; this may cause unnecessary wear or damage to the pump.

## AIR AND LUBE REQUIREMENTS

- **WARNING: DO NOT EXCEED MAXIMUM INLET AIR PRESSURE OF 120 PSI (8 BAR). OPERATING PUMP AT HIGHER PRESSURE MAY CAUSE PUMP DAMAGE AND/OR PERSONAL INJURY AND/OR PROPERTY DAMAGE.**
- A filter capable of filtering out particles larger than 50 microns should be used on the air supply. In most applications there is no lubrication required other than the "O" Ring lubricant which is applied during assembly or repair. When lubricated air is necessary, supply air lubricator with a good grade of SAE 90 wt. non-detergent oil and set lubricator to a rate not to exceed one drop per minute.

## OPERATING INSTRUCTIONS

Always flush the pump with a solvent compatible with material being pumped if the material being pumped is subject to "setting up" when not in use for a period of time. Disconnect air supply from pump if it is to be inactive for a few hours.

The outlet material volume is governed not only by the air supply but also by the supply available at the inlet. The material supply tubing should not be too small or restrictive.

When the diaphragm pump is used in a force-feed (flooded inlet) situation it is recommended that a "Check Valve" be installed at the air inlet. Secure diaphragm legs to a suitable surface to insure against damage by vibration.

## MAINTENANCE

Part views and descriptions are provided on page 4 through 7 for part identification.

This pump is relatively easy to service and maintain. A clean work surface should be provided to protect sensitive internal moving parts from dirt and foreign matter during service. The service kits are divided to service two separate diaphragm pump functions: 1. AIR SECTION 2. FLUID SECTION.

Before disassembling, turn the pump upside down to drain material from pump, this will empty captured material in outlet manifold. The duckbill style pumps cannot be drained in this manner.

## PERFORMANCE DATA

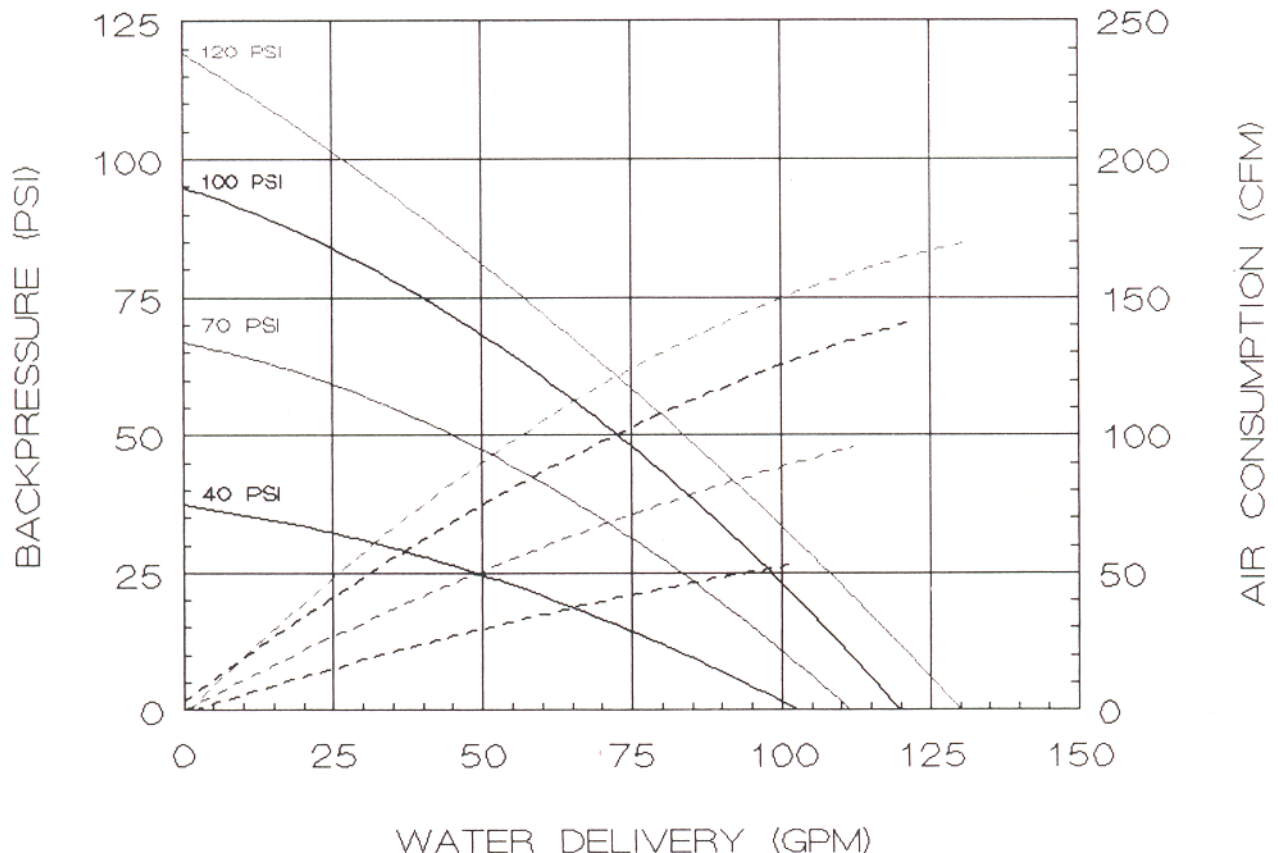



## PARTS LIST/FLUID SECTION

✓ Indicates parts included in 62165 Service Kits

### 650749 FLUID SECTION PARTS LIST

ITEM	DESCRIPTION (SIZE IN INCHES)	(QTY)	PART NO.	(MATL)
1	Diaphragm Rod	(1)	98720-1	(C)
✓ 2	"O" Ring (3/4 O.D.)	(1)	Y330-117	(B)
✓ 3	"O" Ring (5/8 O.D.)	(4)	93003	(E)
5	Washer (6-1/4 O.D.)	(2)	92775	(SS)
6	Washer (6-1/4 O.D.)	(2)	92752	(S)
✓ 7	Diaphragm	(2)	92755-5	(E)
9	Washer (5/8 I.D.)	(2)	93065	(SS)
14	Cap Screw (5/8-18 x 1-1/2)	(2)	Y5-107-T	(SS)
15	Fluid Cap	(2)	92773	(SS)
16	Manifold	(2)	92856	(SS)
19	"O" Ring (2-3/4 O.D.)	(4)	92761	(E)
21	Seat	(4)	92776	(SS)
✓ 22	Ball	(4)	92757-5	(E)
26	Cap Screw (3/8-16 x 1)	(8)	Y6-65-C	(S)
29	Nut (5/16-18)	(20)	Y12-5-C	(SS)
30	Cap Screw (5/16-18 x 2)	(4)	92758	(SS)
31	Washer (5/16)	(4)	Y14-516	(SS)
32	Leg	(2)	92759	(SS)

#### MATERIAL CODE

(B) = Buna "N"  
 (C) = Carbon Steel  
 (E) = E.P.R.  
 (S) = Steel  
 (SS) = Stainless Steel

### FLUID SECTION DISASSEMBLY

- Before disassembling, turn the pump upside down to drain any residual material which may be captured in the outlet manifold.
- 1. Remove the two (16) inlet and outlet manifolds.
- 2. Remove the (22) balls, (19) "O" rings, and (21) seats.
- 3. Remove the (15) fluid caps.
- 4. Use one wrench to loosen the (14) screw while holding opposite (14) screw with a wrench. Remove the (14) screw, (9) washer, (5) washer, (6) washer, (3) "O" Ring, and (7) diaphragm from both sides.
- 5. Remove (2) "O" Ring from (1) diaphragm rod.

NOTE: Do not scratch or mar surface of (1) diaphragm rod.

### FLUID SECTION REASSEMBLY

- Reassemble the pump in reverse order.
- Clean and inspect all parts. Replace worn or damaged parts with new parts as required.
- Lubricate diaphragm rod (10) and "O" ring (11) with Shell Darina Grease 2 lubricant only.

#### WARNING: DO NOT USE FLUOROCARBON BASED MATERIALS TO REASSEMBLE THIS MODEL

- Use PN/98930-T Bullet (installation tool) to aid in installation of "O" ring (2) on diaphragm rod (1).
- Be certain (7) diaphragm aligns properly with the (15) end caps before making final torque adjustments on the (14) cap screw to avoid twisting diaphragm.
- Re-check torque settings after pump has been re-started and run a while.

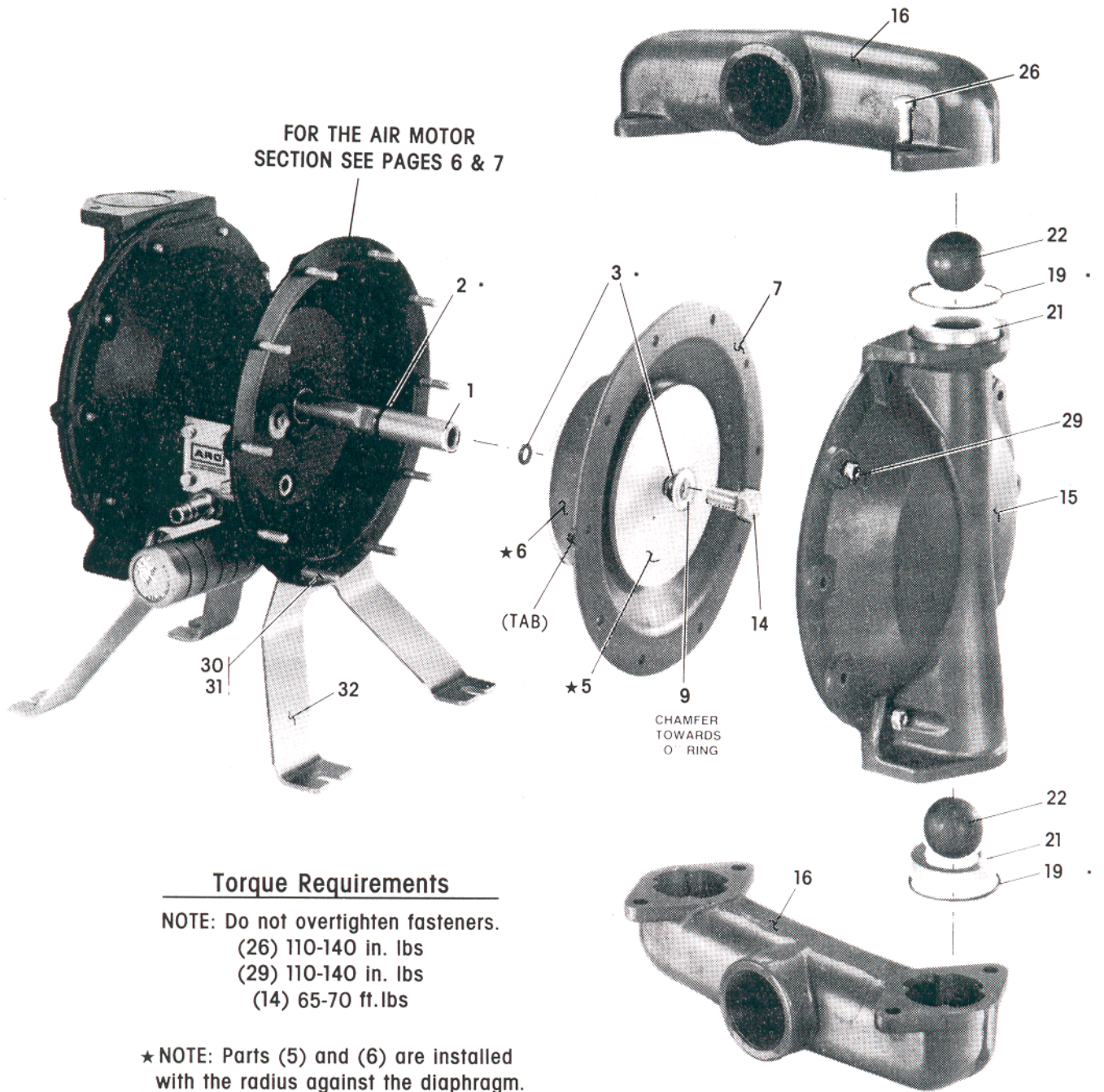

FIGURE 1



## PARTS LIST/AIR MOTOR SECTION

✓ Indicates parts included in 62163 Air Section Service Kit.

ITEM	DESCRIPTION (Size in inches)	(QTY)	PART NO.	(MAT'L)
✓101	Motor Body	(1)	98725-1	(A)
102	"O" Ring (1 O.D.)	(1)	Y325-024	(B)
103	Sleeve	(1)	98718-1	(BZ)
✓104	Retaining Ring, TruArc (1.163 I.D.)	(2)	Y145-26	(S)
✓105	Cap Screw (1/4-20 x 5/8)	(8)	Y6-42-C	(S)
✓106	Washer (1/4)	(8)	Y14-416	(S)
107	Plate	(2)	92756	(C)
108	Gasket (With Notch)	(1)	92878	(B/NY)
109	Piston	(1)	92011	(D)
110	U-Cup (1 3/8 O.D.)	(1)	Y186-51	(B)
111	Spool	(1)	92005	(A)
112	Washer (1.557 O.D.)	(5)	92877	(Z)
✓113	"O" Ring (Small) (1 1/4 O.D.)	(5)	Y325-214	(B)

ITEM	DESCRIPTION (Size in inches)	(QTY)	PART NO.	(MAT'L)
✓114	"O" Ring (Large) (1 9/16" O.D.)	(5)	Y325-126	(B)
115	Spacer	(4)	92876	(Z)
116	Spacer	(1)	92006	(A)
117	Gasket	(1)	92004	(N/NY)
118	Pilot Rod	(1)	93088-2	(C)
✓119	"O" Ring (3/4 O.D.)	(4)	93442-1	(F)
120	Spacer	(3)	115959	(Z)
121	Sleeve Bushing	(2)	98723-2	(BZ)
122	Retaining Ring (1/2)	(2)	77802	(S)
✓123	Screw	(2)	Y212-101	(S)
124	Stud (5/16-18 x 1-3/4)	(16)	92866	(SS)
127	Elbow	(1)	Y43-5-C	(S)
201	Silencer	(1)	93139	(P)

### MATERIAL CODE

(A) = Aluminum	(N) = Neoprene
(B) = Buna "N"	(NY) = Nylon
(BZ) = Bronze	(P) = Polypropylene
(C) = Carbon Steel	(S) = Steel
(D) = Acetal	(SS) = Stainless Steel
(F) = Fluoraz	(Z) = Zinc

### AIR MOTOR SECTION DISASSEMBLY

Disassembly will be done in two parts:

- Part I – Pilot Valve
- Part II – Major Valve

#### AIR MOTOR ASSEMBLY NOTES:

- Lubricate all air motor "O" rings with Shell Darina Grease 2 only.
- WARNING: DO NOT USE FLUOROCARBON BASED MATERIALS IN THIS PUMP FOR REASSEMBLY.**
- Do not over-tighten fasteners.
- (105) Bolts – 40-50 in-lb

### PILOT VALVE DISASSEMBLY

1. Remove (123) screw, (122) retaining rings.
2. Remove (103) sleeve and (102) "O" ring.
3. Remove (104) retaining ring.
4. Remove (118) piston rod, (121) sleeve bushing, (119) "O" rings, and (120) spacers from the (101) motor body.

### PILOT VALVE REASSEMBLY

1. Install one of the (121) sleeve bushings, (119) "O" rings, (120) spacers, and the remaining (121) bushing.
2. Carefully push (118) pilot rod into bushings etc. and retain on each end with the two (122) retaining rings.
3. Replace (102) "O" ring if worn or damaged and reinstall (103) sleeve, replace retaining (104) rings.

### MAJOR VALVE DISASSEMBLY

1. Remove (107) plate (or leg depending on model), (108) and (117) gaskets.
2. On the side opposite air inlet, push on inner diameter (111) spool. This will force the (109) piston out. Continue pushing the (111) spool and remove. Check for scratches and gouges.
3. Reach into the air section (exhaust side) and remove (116) spacer, (115) spacers, (113) "O" rings, (114) "O" rings, (112) washers, etc. Check for damaged "O" rings.

### MAJOR VALVE REASSEMBLY

(Replace with new parts as necessary.) Lubricate "O" rings with Shell Darina Grease 2 only.

**WARNING: DO NOT USE FLUROCARBON BASED MATERIALS IN THIS PUMP FOR REASSEMBLY.**

1. Replace (112) washer, (114) "O" ring, (113) "O" ring onto (115) spacer and insert etc.
- NOTE: Be careful to orient spacer legs away from blocking internal ports.**
2. Lubricate and carefully insert (111) spool.
3. Install (117) gasket and (107).
4. Lubricate and install (110) packing cup and insert (109) piston into (air inlet side) cavity (110) packing cup lips should point outward.
5. Install (108) gasket (see figures 2,3) and (107).

**IMPORTANT**  
 BE CAREFUL TO ORIENT (115) SPACER LEGS  
 AWAY FROM BLOCKING INTERNAL PORTS  
 WHEN REASSEMBLING AIR SECTION.

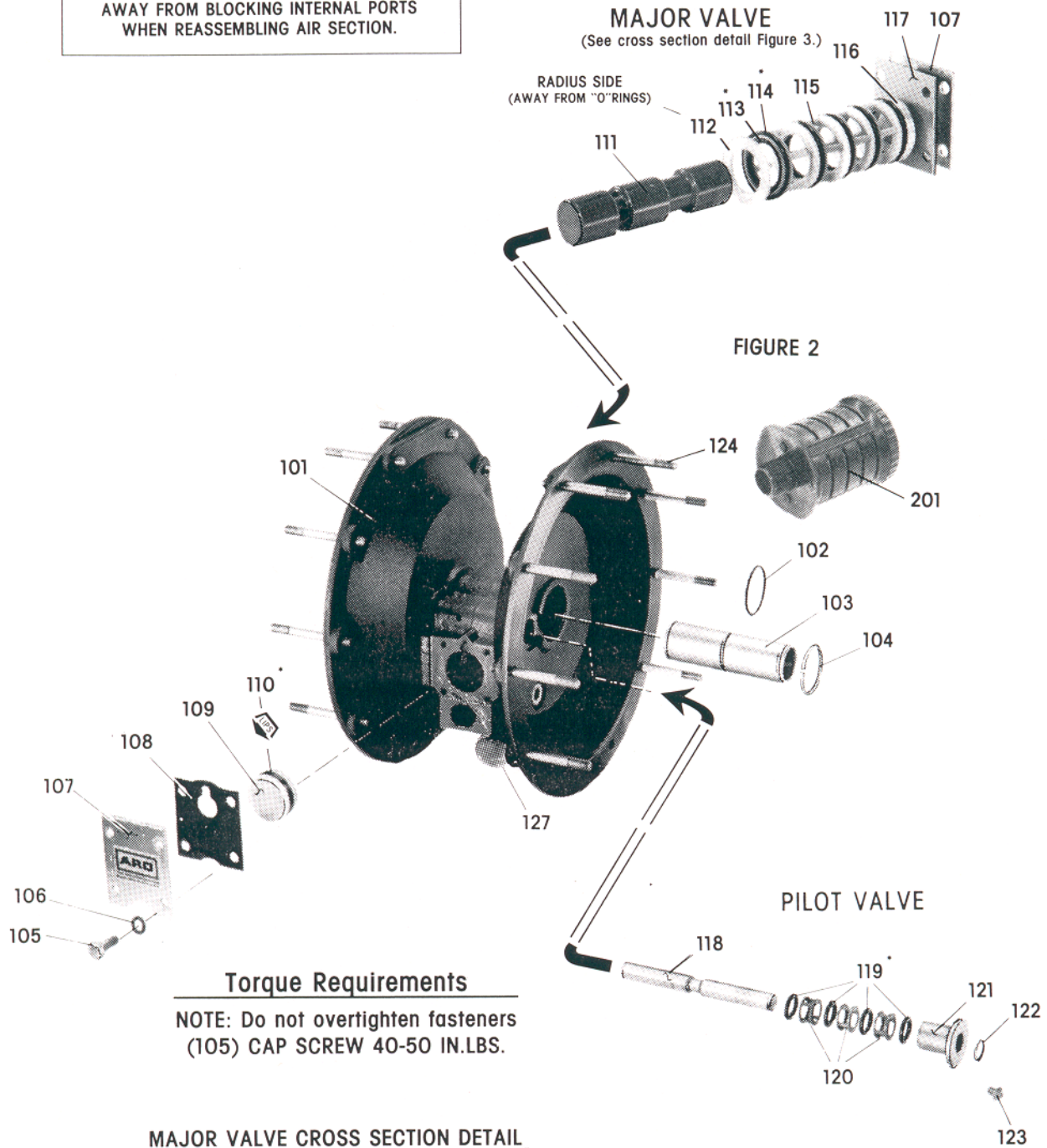

**Torque Requirements**

NOTE: Do not overtighten fasteners  
 (105) CAP SCREW 40-50 IN.LBS.

**MAJOR VALVE CROSS SECTION DETAIL**

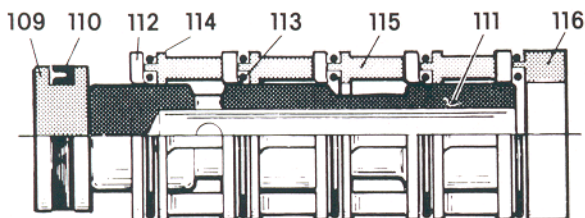

**FIGURE 3**

**\*IMPORTANT**  
 USE ONLY SHELL DARINA GREASE 2 AS A  
 REASSEMBLY LUBRICANT. DO NOT USE  
 FLOUROCARBON MATERIALS FOR LUBRICATION  
 IN THIS PUMP MODEL.

## TROUBLE SHOOTING

### Product discharged from air exhaust

- Check for diaphragm rupture.
- Check tightness of diaphragm nut.

### Air Bubbles in Product Discharge

- Check connections of suction plumbing.
- Check "O" rings between intake manifold and fluid caps.
- Check tightness of diaphragm nut.

### Low output volume, erratic flow, or no flow

- Check air supply.
- Check for plugged outlet hose.
- Check for kinked (restrictive) outlet material hose.
- Check for kinked (restrictive) or collapsed inlet material hose.
- Check for pump cavitation - suction pipe should be 2" min. or larger if high-viscosity fluids are being pumped. Suction hose must be non-collapsible type, capable of pulling a high vacuum.
- Check all joints on intake manifolds and suction connections. These must be airtight.
- Inspect for a solid object lodged in diaphragm area or seat area.

## DIMENSIONAL DATA

ALL DIMENSIONS GIVEN IN INCHES AND MILLIMETERS (MM)

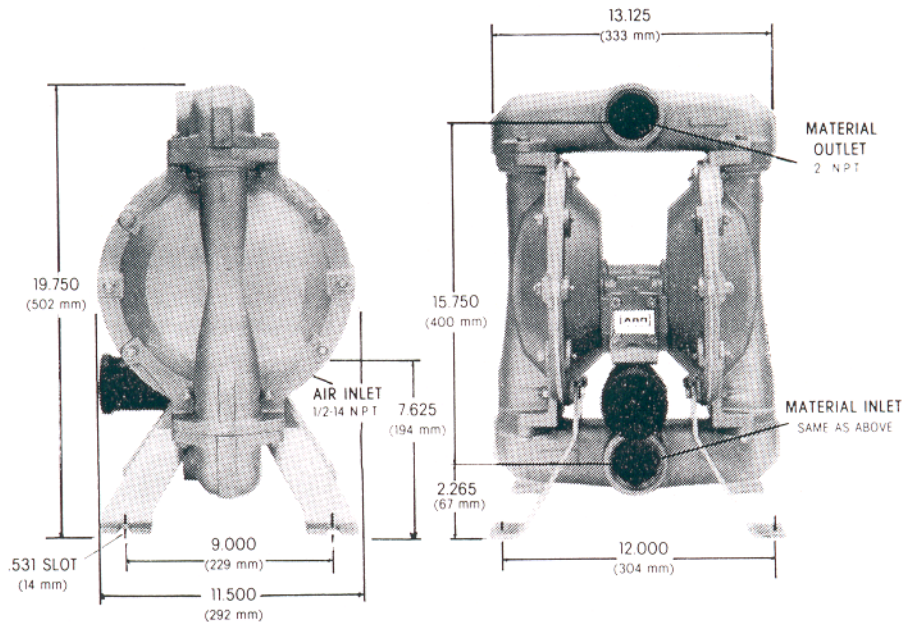

PN 97999-406



## Free Manuals Download Website

<http://myh66.com>

<http://usermanuals.us>

<http://www.somanuals.com>

<http://www.4manuals.cc>

<http://www.manual-lib.com>

<http://www.404manual.com>

<http://www.luxmanual.com>

<http://aubethermostatmanual.com>

Golf course search by state

<http://golfingnear.com>

Email search by domain

<http://emailbydomain.com>

Auto manuals search

<http://auto.somanuals.com>

TV manuals search

<http://tv.somanuals.com>