

OPERATOR'S MANUAL & SALES AND ENGINEERING DATA

INCLUDING: SPECIFICATIONS, SERVICE KITS, GENERAL INFORMATION, TROUBLESHOOTING.
 INCLUDE MANUALS: AF06XX-XX Air Motor (pn 97999-1467), 66266-XXX-B Lower Pump End (pn 97999-829)
 & S-632 General Information Manual (pn 97999-624).

RELEASED: 9-30-10
 (REV. 01)

6" AIR MOTOR
46:1 RATIO
6" STROKE

AF0646SXXXXXX-XX-X EXTRUSION PUMP SERIES Carbon Steel

**READ THIS MANUAL CAREFULLY BEFORE INSTALLING,
 OPERATING OR SERVICING THIS EQUIPMENT.**

It is the responsibility of the employer to place this information in the hands of the operator. Keep for future reference.

SERVICE KITS

- Use only genuine ARO® replacement parts to assure compatible pressure rating and longest service life.
- **637489** for repair of air motor section.
- **637074-X43-B** for repair of lower pump end. Refer to the chart on page 2 for description of -X43 options.

SPECIFICATIONS

Model Series (refer to option chart)	AF0646SXXXXXX-XX-X
Pump Type	Air Operated, Extrusion Double Acting Pump
Ratio	46:1
Air Motor	AF0660-XX
Motor Repair Kit	637489
Motor Diameter	6" (15.2 cm)
Stroke (double acting)	6" (15.2 cm)
Air Inlet (female)	1/2 - 14 N.P.T.F. - 1
Air Exhaust (female)	1-1/4 - 11-1/2 N.P.T.F. - 1
Lower Pump End Series	66266-X43-B
Lower Pump Repair Kit	637074-X43-B
Material Outlet (female)	1 - 11-1/2 N.P.T.F. - 1
Weight	67 lbs (30.4 kgs)

PUMP PERFORMANCE

Air Inlet Pressure Range	0 - 150 p.s.i.g. (0 - 10.3 bar)
Fluid Pressure Range	0 - 7485 p.s.i.g. (0 - 516.2 bar)
Maximum Rec'd Cycles / Minute	60
Displacement In.³ Per Cycle	6.97
Volume / Cycle	3.9 oz. (114.2 ml)
Cycles Per Gallon	33.1
Flow @ 60 Cycles / Minute	1.8 g.p.m. (6.9 l.p.m.)
Noise Level @ 60 p.s.i. - 40 c.p.m. ①	84.7 db(A)*

* The pump sound pressure level has been updated to an Equivalent Continuous Sound Level (LAeq) to meet the intent of ANSI S1.13-1971, CAGI-PNEUROPS S5.1 using four microphone locations.

PUMP DATA

MODEL AF0645SXXXXXX-XX-X

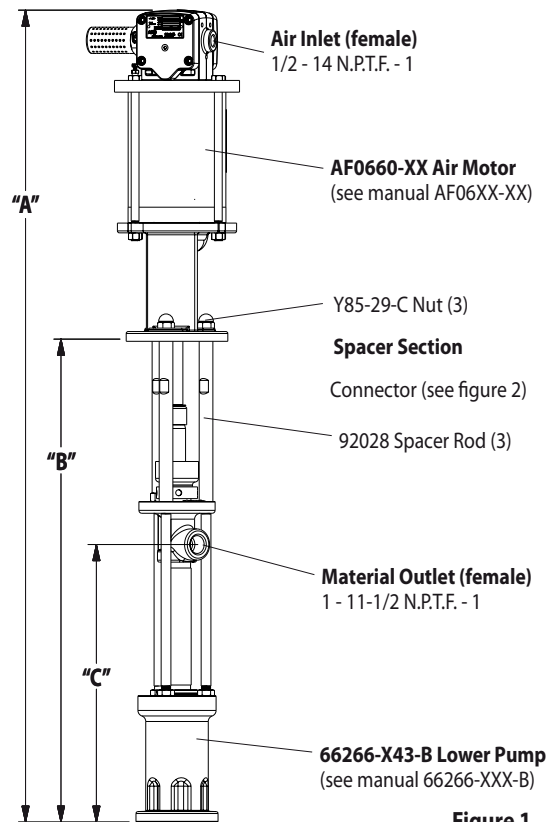

Figure 1

NOTE: Dimensions are shown in inches and (mm) and are supplied for reference only.

"A" (mm)	"B" (mm)	"C" (mm)
51.924" (1318.9)	30.736" (780.7)	17.736" (450.5)
(for -1 model)		
54.009" (1371.8)	30.736" (780.7)	17.736" (450.5)

IMPORTANT

This is one of four documents which support the pump. Replacement copies of these forms are available upon request.

- AF0646SXXXXXX-XX-X** Model Operator's Manual (pn 97999-1508)
- S-632** General Information - Industrial Piston Pumps (pn 97999-624)
- 66266-XXX-B** Lower Pump End Operator's Manual (pn 97999-829)
- AF06XX-XX** Air Motor Operator's Manual (pn 97999-1467)

INGERSOLL RAND COMPANY LTD

209 NORTH MAIN STREET - BRYAN, OHIO 43506

① (800) 495-0276 • FAX (800) 892-6276

© 2010

CCN 15333974

www.ingersollrandproducts.com

ARO

IR Ingersoll Rand
 Industrial Technologies

GENERAL DESCRIPTION

The chop-check pumps are primarily designed for the pumping of heavy viscous material with or without fibrous content. The models can be used with a gravity feed single post lift as a topper type assembly or with a two post lift as a force feed type assembly. The lower pump is designed for easy priming and the double acting feature is standard in all ARO industrial pumps. Material is delivered to the pump discharge outlet on both the up and down stroke.

The motor is connected to the lower pump end by a spacer section. This allows for lubrication of the upper packing gland and prevents motor contamination because of normal wear and eventual leakage through the material packing gland. Be sure the solvent cup is adequately filled with lubricant to protect the upper packings and insure longest service life.

⚠ WARNING HAZARDOUS PRESSURE. Do not exceed maximum operating pressure of 7485 p.s.i. (516.2 bar) at 150 p.s.i. (10.3 bar) inlet air pressure.

Pump Ratio X	=	Maximum Pump Fluid Pressure
Inlet Pressure to Pump Motor		

Pump ratio is an expression of the relationship between the pump motor area and the lower pump end area. EXAMPLE: When 150 p.s.i. (10.4 bar) inlet pressure is supplied to the motor of a 4:1 ratio pump, it will develop a maximum of 600 p.s.i. (41.4 bar) fluid pressure (at no flow) - as the fluid control is opened, the flow rate will increase as the motor cycle rate increases to keep up with the demand.

⚠ WARNING Refer to general information sheet for additional safety precautions and important information.

NOTICE: Thermal expansion can occur when the fluid in the material lines is exposed to elevated temperatures. Example: Material lines located in a non-insulated roof area can warm due to sunlight. Install a pressure relief valve in the pumping system.

Replacement warning label (pn 92325) is available upon request.

TROUBLE SHOOTING

Pump problems can occur in either the air motor section or the lower pump end section. Use these basic guidelines to help determine which section is affected.

Pump will not cycle.

- Be certain to first check for non-pump problems including kinked, restrictive or plugged inlet / outlet hose or dispensing device. Depressurize the pump system and clean out any obstructions in the inlet / outlet material lines.
- Refer to the motor manual for trouble shooting if the pump does not cycle and / or air leaks from the air motor.
- Damaged motor. Service the motor.

Pump cycles but does not deliver material.

- Refer to the lower pump end manual for further trouble shooting.

PUMP CONNECTION - UPPER / LOWER

NOTE: All threads are right hand.

1. Lay the pump assembly on a work bench.
2. Remove the three (Y85-29-C) nuts from the three spacer rods (see figure 1).
3. Pull the air motor from the lower pump end until the motor piston rod is in the "down" position and the lower pump end rod is in the "up" position.
4. Using e-ring pliers, slide the retaining ring up far enough to allow the sleeve to move upward and release the two connectors (see figure 2). Lay the air motor aside.
5. Repeat step 4 to remove the other connector, then remove the extension rod.
6. Unscrew the three (92028) spacer rods only if disassembly of the lower pump end is necessary.

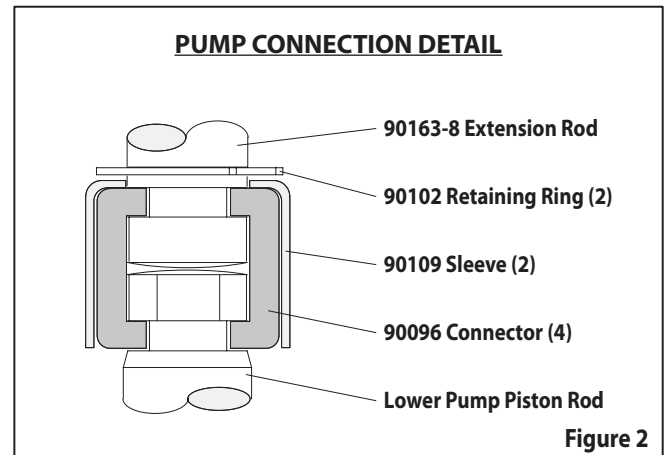

REASSEMBLY

1. Align the pump motor and extension rod with the lower pump end. Position the air inlet of the motor 30° from the material outlet.
2. Install the two (90096) connectors and retain with the (90109) sleeve. Slide the (90102) retaining ring back into position.
3. Assemble the three (92028) spacer rods to the lower pump end and torque evenly to 60 - 90 ft lbs (81.3 - 122.0 Nm).
4. Bring the motor and lower pump together and retain with three (Y85-29-C) nuts.

PERFORMANCE CURVES

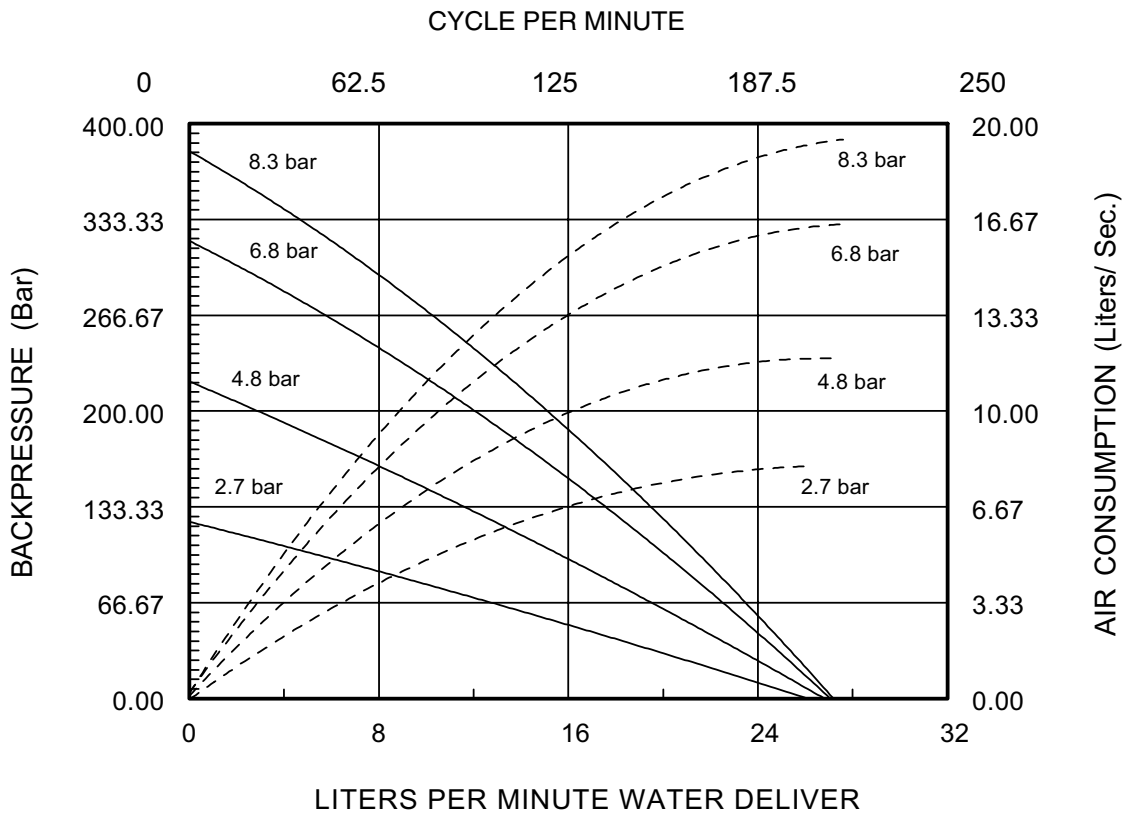
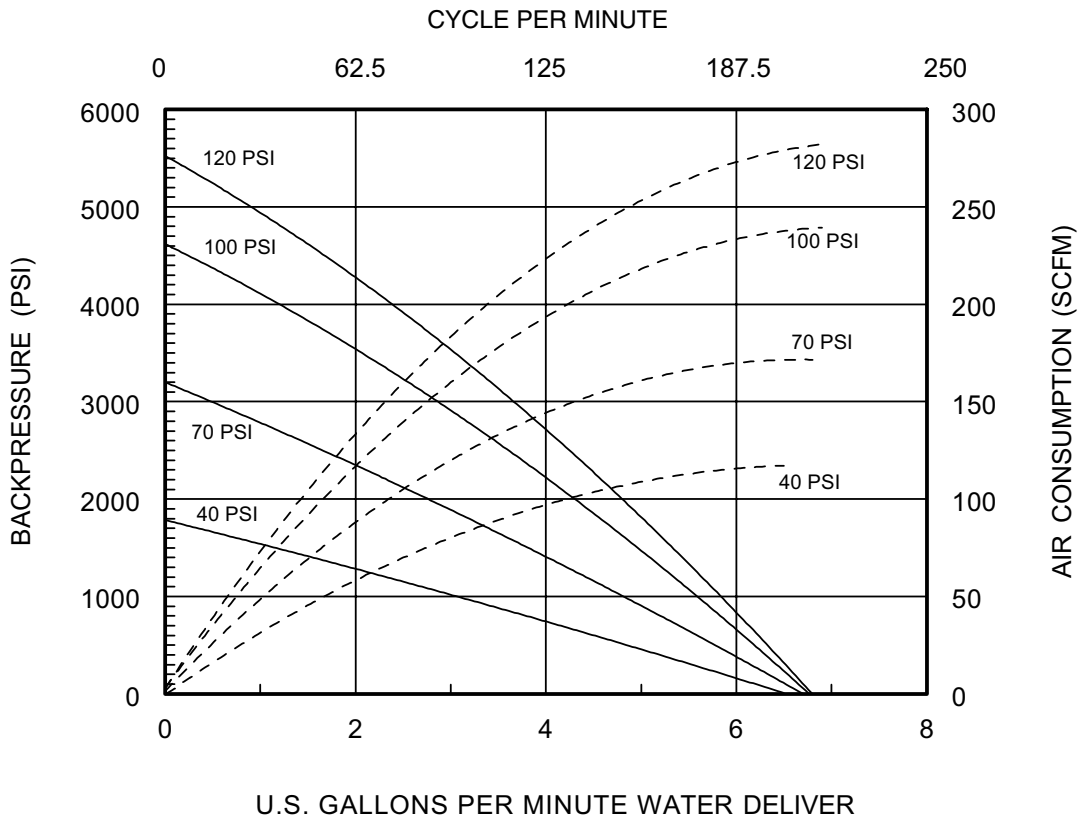

Free Manuals Download Website

<http://myh66.com>

<http://usermanuals.us>

<http://www.somanuals.com>

<http://www.4manuals.cc>

<http://www.manual-lib.com>

<http://www.404manual.com>

<http://www.luxmanual.com>

<http://aubethermostatmanual.com>

Golf course search by state

<http://golfingnear.com>

Email search by domain

<http://emailbydomain.com>

Auto manuals search

<http://auto.somanuals.com>

TV manuals search

<http://tv.somanuals.com>