

OPERATOR'S MANUAL

612729

INCLUDING: SERVICE KITS, GENERAL DESCRIPTION & TROUBLESHOOTING
ALSO INCLUDE MANUALS: 662420-B BASIC PUMP MANUAL (PN 97999-108)
& S-632 GENERAL INFORMATION (PN 97999-624).

RELEASED: 12-1-64
REVISED: 1-18-11
(REV. F)

4-1/4" AIR MOTOR
9:1 RATIO
4" STROKE

OIL SUPPLY PUMP STUB



**READ THIS MANUAL CAREFULLY BEFORE INSTALLING,
OPERATING OR SERVICING THIS EQUIPMENT.**

It is the responsibility of the employer to place this information in the hands of the operator. Keep for future reference.

SERVICE KITS

- 61268 for repair of Air Motor section.
- 61053 for repair of entire pump.
- 65823 for repair of Base Packing.
- Use only genuine ARO® replacement parts to assure compatible pressure rating and longest service life.

GENERAL DESCRIPTION

This model is designed for high volume delivery of low viscosity fluids from standard containers. The model covered by this manual includes an outlet swivel, material supply hoses and airline lubricator. Material dispensing accessories and supply lines and fittings must be capable of withstanding pressures developed by the pump.

- The ARO® 9:1 ratio basic pump assembly consists of 4-1/4" air motor and two ball lower pump end.

**PUMP RATIO X
INLET PRESSURE TO PUMP MOTOR = MAXIMUM PUMP
FLUID PRESSURE**

Pump ratio is an expression of the relationship between the pump motor area and the lower pump end area. EXAMPLE: When 150 p.s.i. (10 bar) inlet pressure is supplied to the motor of a 9:1 ratio pump it will develop a maximum of 1350 p.s.i. (93 bar) fluid pressure (at no flow) - as the fluid control is opened, the flow rate will increase as the motor cycle rate increases to keep up with the demand.

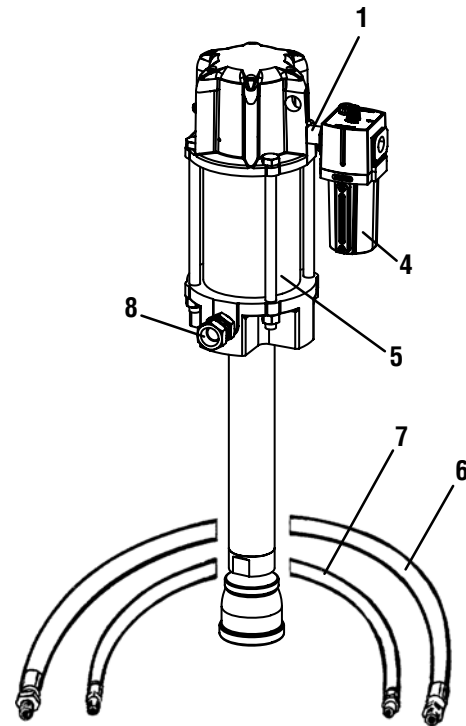

AIR AND LUBE REQUIREMENTS

⚠ WARNING HAZARDOUS PRESSURE. Do not exceed maximum inlet air pressure of 150 psi (10 bar). Operating pump at higher pressure may cause pump damage and/or personal injury and/or property damage.

⚠ WARNING Refer to general information sheet for additional safety precautions and important information.

- Excessive air pressure will shorten the life of the pump.
- For maximum operating efficiency, the following air supply specifications should be maintained to this pump.
 - AIR PRESSURE - Up to 150 P.S.I. (10 Bar)
 - AIR FILTRATION - 50 micron
 - LUBRICATED AIR SUPPLY
 - AIR INLET SIZE - 1/2" NPTF

ACCESSORIES LIST

ITEM	Description	Qty	Part No.
1	Nipple (1/2 x 1-1/8)	1	Y27-154-C
4	Lubricator ★	1	L36341-110
5	Basic Pump ★	1	662420-B
6	Material Hose	1	624601-4
7	Air Hose	1	621501-3
8	Swivel	1	75367

★ SEE OPERATOR'S MANUAL

INGERSOLL RAND COMPANY LTD

209 NORTH MAIN STREET - BRYAN, OHIO 43506

① (800) 495-0276 • FAX(800) 892-6276

© 2011

www.ingersollrandproducts.com

ARO

IR Ingersoll Rand
Industrial Technologies

AIR AND LUBE REQUIREMENTS (cont)

- Filtered and oiled air will allow the pump to operate more efficiently and yield a longer life to operating parts and mechanisms.
- Lack of or an excessive amount of lubrication will affect the performance and life of this pump. Use only recommended lubricants.
- DAILY Fill air line lubricator with a good grade of S.A.E. NO. 90W non-detergent gear oil, adjust to 1 to 2 drops per minute.
- If pump is to be inoperative for more than a few hours at a time, disconnect air supply and relieve all pressure from the system.

It is recommended that an oiler be installed in the air line as close as possible to the pump. This increases the service life of the pump by reducing wear of the air motor's internal parts.

TROUBLE-SHOOTING

Should pump operate, but dispense little or no material, check for:

- Inadequate supply of material or possible malfunctioning of 77006 Foot Valve which would prevent material from feeding into suction tube.
- Dirt or foreign matter in 77006 Foot Valve or other cause which may be preventing it from closing on downstroke of piston.

If unit should fail to operate, the following procedure will be helpful in determining the cause:

- Check air pressure at pump to insure air line is not obstructed and air is being supplied to pump.
- If insufficient air is not the trouble, disconnect air supply to pump and then detach Hose and Gun at 75367 Swivel. **REMOVE SLOWLY AS PRESSURE MAY BE BUILT UP IN PUMP.** Hold rag at this point and apply air to pump. If pump now operates, there is obstruction in material line, reel, or control handle. If, however, pump will still not operate, consult local dealer,

Free Manuals Download Website

<http://myh66.com>

<http://usermanuals.us>

<http://www.somanuals.com>

<http://www.4manuals.cc>

<http://www.manual-lib.com>

<http://www.404manual.com>

<http://www.luxmanual.com>

<http://aubethermostatmanual.com>

Golf course search by state

<http://golfingnear.com>

Email search by domain

<http://emailbydomain.com>

Auto manuals search

<http://auto.somanuals.com>

TV manuals search

<http://tv.somanuals.com>