

INCLUDING: SERVICE KITS, TROUBLESHOOTING, PARTS LIST,
DISASSEMBLY & REASSEMBLY.

RELEASED: 1-19-01
REVISED: 3-31-10
(REV. F)

CHOP-CHECK STYLE LOWER PUMP ENDS

Also covers 637348-XXD service kits



**READ THIS MANUAL CAREFULLY BEFORE INSTALLING,
OPERATING OR SERVICING THIS EQUIPMENT.**

It is the responsibility of the employer to place this information in the hands of the operator. Keep for future reference.

SERVICE KITS

Use only genuine ARO® replacement parts to assure compatible pressure rating and longest service life.
637348-XXD for general repair of 67300-XXX lower pump ends.

GENERAL DESCRIPTION

⚠ WARNING DO NOT EXCEED MAXIMUM OPERATING PRESSURE AS INDICATED ON PUMP MODEL PLATE.

⚠ WARNING REFER TO GENERAL INFORMATION SHEET FOR ADDITIONAL SAFETY PRECAUTIONS AND IMPORTANT INFORMATION.

- This manual covers the lower pump section. It is one of four documents which support an ARO pump. Replacement copies of these forms are available upon request.
 - 650XXX-X Pump Model Operator's Manual.
 - General Information for Air Operated or Hydraulically Operated Pumps.
 - Lower Pump End Operator's Manual.
 - Air or Hydraulic Motor Operator's Manual.
- The chop-check design provides for easy priming of the lower foot valve. The double acting feature is standard in all ARO industrial pumps. Material is delivered to the pump discharge outlet on both the up and down stroke.

MAINTENANCE

The air / hydraulic motor is completely separate from the lower pump end. This helps to keep the motor from being contaminated by the material being pumped. Periodically, flush entire pump system with a solvent that is compatible with the material being pumped.

Keep solvent cup filled with this compatible solvent. This will keep material from drying on the piston rod, which would drag thru the packings, ruin them and eventually scour the piston rod.

Provide a clean work surface to protect sensitive internal moving parts from contamination from dirt and foreign matter during disassembly and reassembly.

Before reassembling, lubricate parts as required. When assembling "O" rings, or parts adjacent to "O" rings, exercise care to prevent damage to "O" rings and "O" ring groove surface.

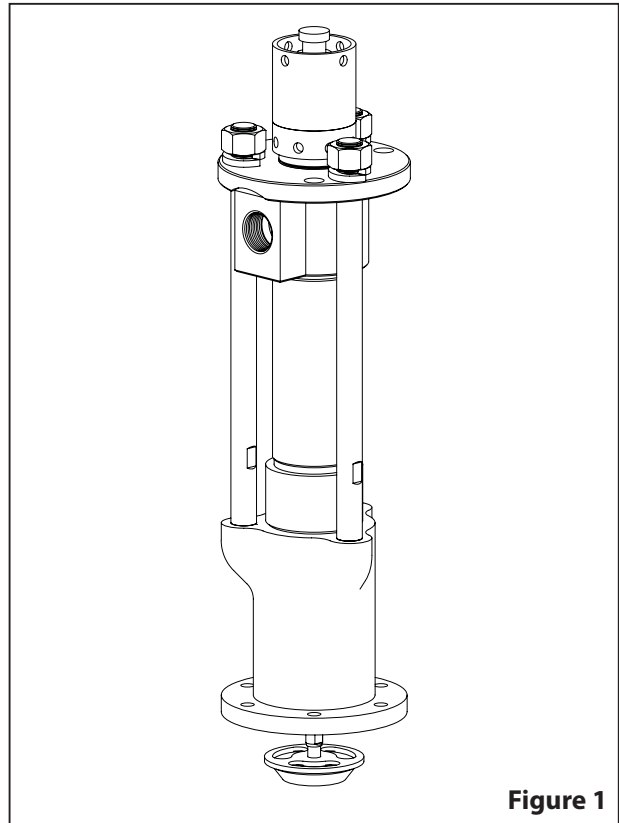

Figure 1

LOWER PUMP END DESCRIPTION CHART

67300 - X X X	
Packing Material	C - UHMW-PE (upper and lower) J - Polyurethane (upper) - UHMW-PE (lower)
Spring Arrangement	3 - No spring 4 - Multiple wave spring
Plunger Type	D - Hardened stainless steel with hard chrome plating
Service Kit Selection	67300 - X X X 637348 - X X X D Example: Lower Pump End # 67300-J3D Service Kit # 637348-J3D
	Packing — Spring

INGERSOLL RAND COMPANY LTD

209 NORTH MAIN STREET – BRYAN, OHIO 43506

(800) 495-0276 • FAX(800) 892-6276

www.ingersollrandproducts.com

© 2010 CCN 99907461

ARO

IR Ingersoll Rand
Industrial Technologies

PARTS LIST

Item	Description (size)	(Qty)	Part No.	Mtl
1	Solvent Cup	(1)	92689	[C]
2	Lower Gland (models 67300-C4D)	(1)	95254	[C]
	(models 67300-J3D)	(1)	95327	[C]
3	"O" Ring (1/16" x 3" o.d.)	(1)	Y325-40	[B]
5	Bushing (models 67300-C4D)	(1)	95255	[D]
	(models 67300-J3D)	(1)	95328	[D]
6	Outlet Body	(1)	95263	[C]
✓ 7	"O" Ring (1/16" x 3-1/8" o.d.)	(2)	Y328-41	[T]
9	Tube	(1)	95261	[C]
10	Stud	(3)	95351	[C]
12	Nut (1" - 14)	(3)	Y11-16-C	[C]
14	Upper Gland Nut (models 67300-J3D only)	(1)	95326	[C]
15	Pressure Chamber Body	(1)	95308-B	[I]
17	Lock Washer (1")	(3)	Y14-100-C	[C]
✓ 18	Retaining Ring (2.295" o.d.) (67300-J3D only)	(1)	76243-2	[SS]
21	Foot Valve Body	(1)	92682	[SH]
22	Check Valve Seat	(1)	96830	[SH]
25	Check Stop	(1)	95262	[SS]
26	Plunger	(1)	95270-1	[PSH]
27	Valve Seat	(1)	95307	[SH]
28	Valve Seat	(1)	95267	[SH]
30	Primer Rod	(1)	91719	[SH]

MATERIAL CODE

[B] = Nitrile	[SH] = Hardened Stainless Steel
[C] = Carbon Steel	[SS] = Stainless Steel
[D] = Acetal	[T] = PTFE
[GFT] = Glass filled PTFE	[U] = Urethane
[I] = Iron	[UH] = UHMW-PE
[PSH] = Hard Chrome Plated Hardened Stainless Steel	

LOWER PUMP DISASSEMBLY

NOTE: All threads are right hand.

- Using a wrench on flats of (30) primer rod and a 5/8" wrench on (33) lock nut, remove (33) lock nut, releasing (32) primer button and (31) primer plate.
- Using a wrench on flats of (10) stud and an 1-1/2" wrench on (12) nut, remove three (12) nuts and (17) lock washers from (10) studs.
- Remove (6) outlet body, (9) tube and components from (15) pressure chamber body.
- Remove (7) "O" ring from (25) check stop.
- Using a wrench on flats of (10) stud, remove three (10) studs.
- Using a wrench on flats of (30) primer rod, remove (30) primer rod from (34) valve rod.
- Remove (9) tube and (7) "O" ring from (6) outlet body.
- Remove (34) valve rod from (26) plunger, releasing (28) valve seat and components.
- Clamp the (28) valve seat in a vise and remove (36) valve seat nut, releasing (47) bowed washer, (57) male packing washer, five (55) "V" packings and (54) female packing washer.
- Remove (1) solvent cup and (3) "O" ring from (2) lower gland.
- Remove (26) plunger.
- Remove (2) lower gland and (38) "O" ring from (6) outlet body.
- Models 67300-J3D:** Remove (14) upper gland nut, releasing (5) bushing and two (64) seals. Remove (18) retaining ring, releasing (64) seal.
- Models 67300-C4D:** Remove (43) wave spring, (57) male packing washer, five (55) "V" packings, (54) female packing washer and (5) bushing from (2) lower gland.
- Remove (25) check stop from (15) pressure chamber body.
- Remove (21) foot valve body from (15) pressure chamber

Item	Description (size)	(Qty)	Part No.	Mtl
31	Primer Plate	(1)	93599-1	[SS]
32	Primer Button	(1)	93598-1	[SS]
33	Lock Nut (7/16" - 20)	(1)	Y171-7-C	[C]
34	Valve Rod	(1)	95306	[SH]
36	Valve Seat Nut	(1)	95269	[C]
✓ 37	Retaining Ring (1.136" o.d.)	(1)	Y147-102	[C]
✓ 38	"O" Ring (1/16" x 2-5/8" o.d.)	(1)	Y328-37	[T]
43	Wave Spring (models 67300-C4D only)	(1)	95259	[SH]
✓ 44	"O" Ring (1/8" x 3-1/2" o.d.)	(1)	Y328-236	[T]
✓ 47	Bowed Washer	(1)	95266	[C]
54	Female Packing Washer (67300-C4D)	(2)	95256	[D]
	(models 67300-J3D)	(1)	95256	[D]
✓ 55	"V" Packing (models 67300-C4D)	(10)	95257-4	[UH]
	(models 67300-J3D)	(5)	95257-4	[UH]
57	Male Packing Washer (models 67300-C4D)	(2)	95258	[C]
	(models 67300-J3D)	(1)	95258	[C]
✓ 64	Seal (models 67300-J3D only)	(3)	95325	[U]
✓ 65	"U" Cup	(1)	90911	[GFT]
88	Bleeder Valve Body	(1)	97206	[C]
89	Needle Bleed Valve	(1)	97207	[C]
✓	Items included in Service Kit		637348-XXD	

body.

- Remove (37) retaining ring, releasing (65) "U" cup from (21) foot valve body.
- Remove (44) "O" ring and (22) check valve seat from (15) pressure chamber body.

LOWER PUMP REASSEMBLY

NOTE: All threads are right hand.

- Assemble (22) check valve seat and (44) "O" ring into (15) pressure chamber body. NOTE: Assemble (22) check valve seat with i.d. chamfer up.
- Assemble (65) "U" cup into (21) foot valve body, securing with (37) retaining ring. NOTE: Assemble "U" cup with lips facing up.
- Assemble (21) foot valve body into (15) pressure chamber body.
- Assemble (25) check stop assembly into (15) pressure chamber body.
- Assemble (7) "O" ring into (6) outlet body.
- Assemble (38) "O" ring into (6) outlet body.
- Models 67300-J3D:**
 - Assemble one (64) seal into bottom of (2) lower gland, securing with (18) retaining ring. NOTE: Assemble (64) seal with lips facing out.
 - Assemble two (64) seals into (2) lower gland, with lips into gland first.
 - Assemble (5) bushing into (2) lower gland.
 - Apply PTFE tape to threads of (14) upper gland nut and assemble to (2) lower gland.
- Models 67300-C4D:** Assemble (5) bushing, (54) female packing washer, five (55) "V" packing, (57) male packing washer and (43) wave spring. NOTE: Assemble (54) female packing washer and (55) "V" packing with lips facing out.
- Apply Loctite 242 to threads of (2) lower gland and assemble to (6) outlet body.
- Assemble (26) plunger into (6) outlet body from the bottom end.
- Tighten (2) lower gland securely.

(continued on page 4)

PARTS LIST

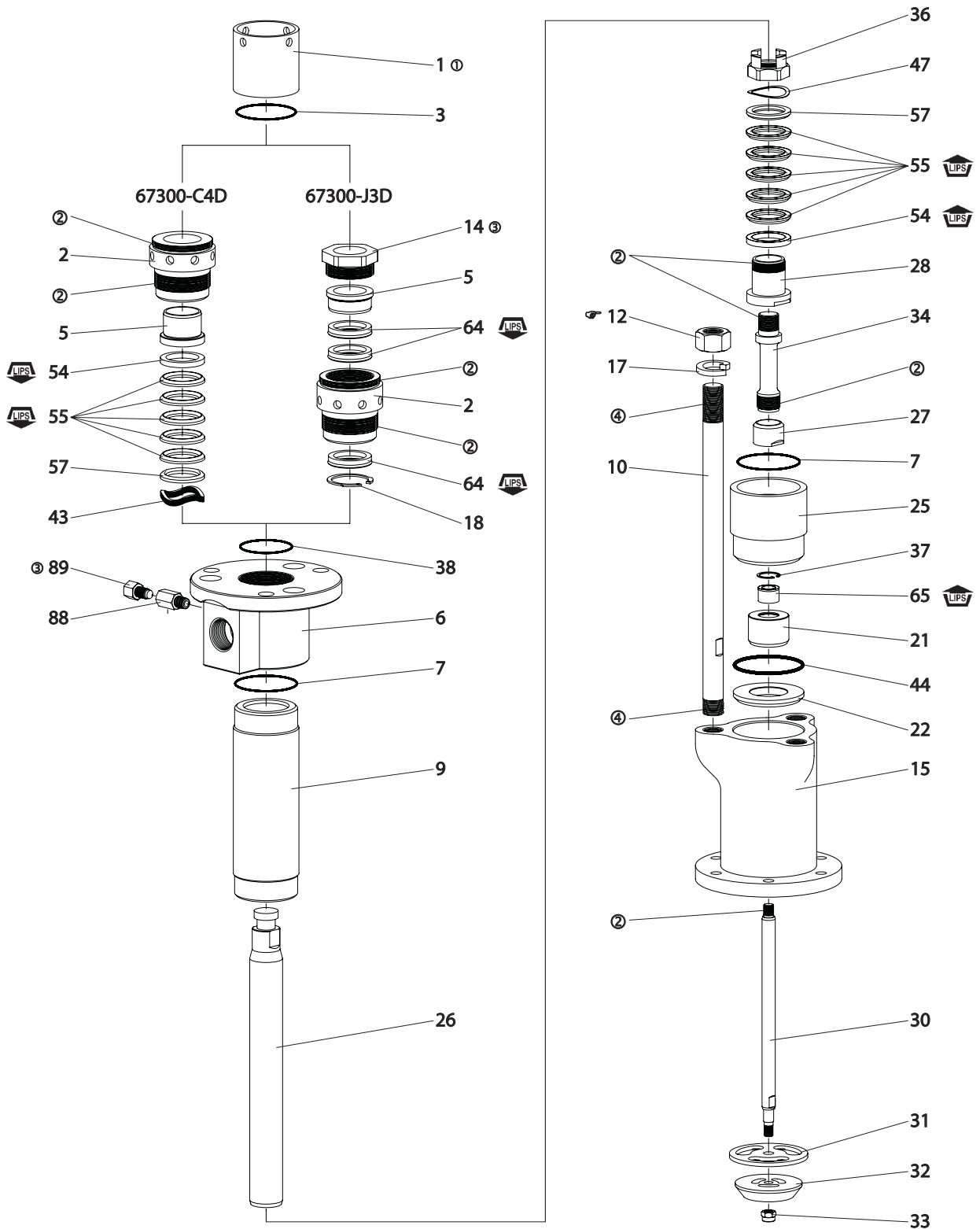

Figure 2

ASSEMBLY TORQUE REQUIREMENTS

NOTE: DO NOT OVERTIGHTEN FASTENERS.
 (12) Nut, tighten to 300 ft lbs (406.7 Nm).

LUBRICATION / SEALANTS

- ① Keep solvent cup filled with a lubricant such as Wet-Sol "Plus" or equivalent.
- ② Apply Loctite® 242® to threads.
- ③ Apply PTFE tape to threads.
- ④ Apply Lubriplate® FML-2 grease to threads.

12. Using an open end wrench, tighten (14) upper gland nut.
13. Assemble (3) "O" ring to (2) lower gland.
14. Apply Loctite 242 to threads of (1) solvent cup and (2) lower gland.
15. Assemble (1) solvent cup to (2) lower gland and tighten, using a spanner wrench.
16. Apply PTFE tape to threads of (89) bleed valve. Assemble (89) bleed valve to (88) valve body and assemble (88) valve body to (6) outlet body. Tighten with outlet of (88) valve body pointed downward.
17. Secure (6) outlet body and components in a vise, clamping on flats of (26) plunger.
18. Assemble (54) female packing washer, five (55) "V" packings, (57) male packing washer and (47) bowed washer to (28) valve seat, securing with (36) valve seat nut. NOTE: Apply Loctite 242 to threads of (28) valve seat and (36) valve seat nut. NOTE: Assemble "V" packings with lips facing up.
19. Apply Loctite 242 to threads of (34) valve rod and assemble to (27) valve seat.
20. Assemble (28) valve seat and components to (26) plunger.
21. Apply Loctite 242 to threads of (34) valve rod and assemble (34) valve rod thru (28) valve seat and thread into (26) plunger.
22. Using Wet Sol "Plus", lubricate the i.d. of (9) tube and the o.d. of (55) "V" packings and assemble (9) tube over "V" packings and into (6) outlet body.
23. Apply Loctite 242 to threads of (30) primer rod and assemble to (34) valve rod.
24. Apply Lubriplate to threaded holes of (15) pressure chamber body and assemble three (10) studs to (15) pressure chamber body.
25. Assemble (7) "O" ring into (25) check stop.
26. Assemble (6) outlet body, (9) tube and components to (15) pressure chamber body, aligning holes in (6) outlet body with (10) studs.
27. Lubricate threads of (10) studs with Lubriplate and assemble three (17) lock washers and (12) nuts to (10) studs and tighten to 300 ft lbs (407 Nm).
28. Assemble (31) primer plate and (32) primer button to (30) primer rod, securing with (33) lock nut.

TROUBLE SHOOTING

No material at outlet (pump continually cycles).

- Check material supply. Disconnect or shut off the air supply and replenish the material, reconnect.

Material on one stroke only (fast downstroke).

- The (21) foot valve body may not be seating in the (22) check valve seat (see lower pump disassembly). Remove the (21) foot valve body from the (22) check valve seat, clean and inspect the check valve seat area. If the foot valve or seat is damaged, replace.

Material on one stroke only (fast upstroke).

- The (27) valve seat may not be seating in the (28) valve seat (see lower pump disassembly). Remove (27) valve seat from (28) valve seat, clean and inspect. If the (27) valve seat is damaged, replace. Check for worn or damaged packings and seals. Replace the packings and seals as necessary.

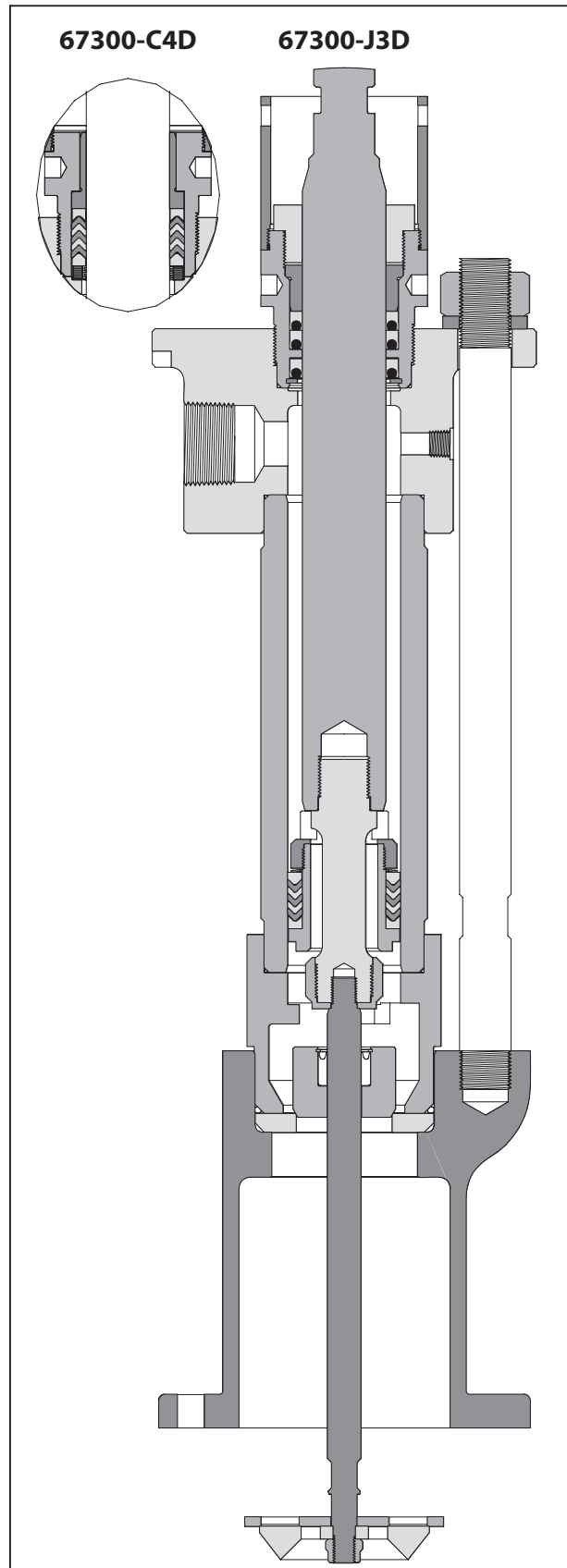

- ARO® is a registered trademark of Ingersoll-Rand Company •
- Loctite® and 242® are registered trademarks of Henkel Loctite Corporation •
- Lubriplate® is a registered trademark of Lubriplate Division (Fiske Brothers Refining Company) •

Free Manuals Download Website

<http://myh66.com>

<http://usermanuals.us>

<http://www.somanuals.com>

<http://www.4manuals.cc>

<http://www.manual-lib.com>

<http://www.404manual.com>

<http://www.luxmanual.com>

<http://aubethermostatmanual.com>

Golf course search by state

<http://golfingnear.com>

Email search by domain

<http://emailbydomain.com>

Auto manuals search

<http://auto.somanuals.com>

TV manuals search

<http://tv.somanuals.com>