

1" DIAPHRAGM PUMP 1:1 RATIO (METALLIC)

**IMPORTANT: READ THIS MANUAL CAREFULLY BEFORE INSTALLING,
OPERATING OR SERVICING THIS EQUIPMENT.**

THIS MANUAL COVERS THE FOLLOWING MODELS

MODEL	TH'D	DIAPHRAGM MATERIAL	APPLICATION
650748	NPT	EPR	FLUOROCARBON-FREE USE

SERVICE KITS

62163 for Air Section repair. (See page 6.)
62164 for repair of Fluid Section.

PUMP DATA

MODEL - 650748

PUMP TYPE - Metallic Air Operated Double Diaphragm
for use with Non-Fluorocarbon applications

MATERIAL - Aluminum Center Body, Stainless Steel Fluid Caps,
Manifolds, Seats, EPR Balls and Diaphragms.

WEIGHT - 18.5 lbs

MAXIMUM AIR INLET PRESSURE - 120 p.s.i. (8 bar)

MAXIMUM OUTLET PRESSURE - 120 p.s.i. (8 bar)

MAXIMUM FLOW RATE (FLOODED INLET) 0-35 g.p.m.

MAXIMUM PARTICLE SIZE - 1/4" dia.

DIMENSIONAL DATA - See page 8.

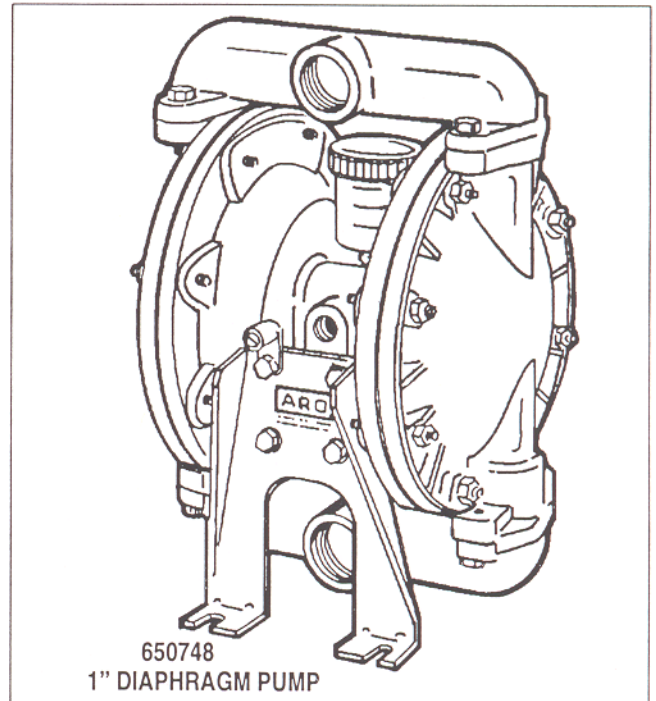

OPERATING AND SAFETY PRECAUTIONS

▲ Read and heed all Warnings, Cautions, and Safety Precautions before operating this pump.

▲ Use only genuine ARO replacement parts to assure compatible pressure rating and longest service life.

▲ **WARNING: EXCESSIVE AIR PRESSURE.** CAN CAUSE PUMP AND PROPERTY DAMAGE. DO NOT EXCEED THE MAXIMUM INLET AIR PRESSURE AS STATED ON THE PUMP MODEL PLATE.

▲ **WARNING: STATIC SPARK.** FAILURE TO SAFEGUARD AGAINST STATIC SPARK, OPEN FLAME, HEAT AND IMPROPER VENTILATION COULD RESULT IN FIRE OR EXPLOSION CAUSING SEVERE PERSONAL INJURY AND/OR PROPERTY DAMAGE. THE PUMP MUST BE GROUNDED WHEN IT IS PUMPING, FLUSHING, OR RECIRCULATING INFLAMMABLE SUBSTANCES SUCH AS: PAINTS SOLVENTS, LACQUERS, ETC. OR USED IN A LOCATION WHERE SURROUNDING ATMOSPHERE IS CONDUCTIVE TO SPONTANEOUS COMBUSTION.

- Use the pump grounding lug provided on metallic pumps for connection of a 12 ga. (min.) wire to a good earth ground source.
- Ground dispensing valve or device, containers, hoses and any object to which material is being pumped.
- After grounding, periodically verify continuity of electrical path to ground. Test with an ohmmeter from each component (e.g., hoses, pump, clamps, container, spray gun, etc.) to ground to insure continuity. Ohmmeter should show 10 ohms or less.
- Secure pump, connections and all contact points to avoid vibration and generation of contact or static spark.
- Consult local building codes and electrical codes for specific grounding requirements.

▲ **WARNING: DIAPHRAGM RUPTURE.** CAN CAUSE SERIOUS INJURY OR PROPERTY DAMAGE. MATERIAL CAN BE FORCED OUT OF THE AIR EXHAUST MUFFLER.

- Pipe the exhaust to a safe remote location when pumping hazardous or inflammable materials.
- Use a grounded 3/8" min. I.D. hose between the pump and the muffler.

▲ **WARNING: HAZARDOUS PRESSURE.** CAN RESULT IN SERIOUS INJURY OR PROPERTY DAMAGE. DO NOT SERVICE OR CLEAN PUMP, HOSES OR DISPENSING VALVE WHILE THE SYSTEM IS PRESSURIZED.

- Disconnect air supply line and relieve pressure from the system by opening dispensing valve or device and/or carefully and slowly loosening and removing outlet hose or piping from pump.

▲ **WARNING: HAZARDOUS MATERIALS.** CAN CAUSE SERIOUS INJURY OR PROPERTY DAMAGE. DO NOT ATTEMPT TO RETURN A PUMP TO THE FACTORY OR SERVICE CENTER THAT CONTAINS HAZARDOUS MATERIAL. SAFE HANDLING PRACTICES MUST COMPLY WITH LOCAL AND NATIONAL LAWS AND SAFETY CODE REQUIREMENTS.

- Obtain Material Safety Data Sheets on all materials from the supplier for proper handling instructions.

▲ **SAFETY PRECAUTIONS (GENERAL)** should include:

- Use of static wire hoses.
- Submersion of outlet hose end, dispensing valve or device within material being dispensed whenever possible. (Avoid free streaming of material being dispensed.)
- Proper ventilation of area away from heat, open flames and sparks.
- Keeping inflammables away from heat, open flames and sparks.
- Keeping containers closed when not in use.
- Be sure material hoses and other components are able to withstand fluid pressures developed by this pump. Check all hoses for damage or wear. Be certain dispensing device is clean and in proper working condition.

▲ **CAUTION:** Verify the chemical compatibility of the pump wetted parts and the substance being pumped, flushed or recirculated. Chemical compatibility may change with temperature and concentration of the chemical(s) within the substances being pumped, flushed or circulated. Consult ARO Form No. 8677-P, Fluid Compatibility Guide, for information on chemical compatibility.

▲ **CAUTION:** Maximum temperatures are based on mechanical stress only. Certain chemicals will significantly reduce maximum safe operating temperature. Consult Fluid Compatibility Guide for chemical compatibility and temperature limits.

▲ **CAUTION:** Be certain all operators of this equipment have been trained for safe working practices, understand its limitations, and wear safety goggles/equipment when required.

▲ **CAUTION:** Do not use the pump for the structural support of the piping system. Be certain the system components are properly supported to prevent stress on the pump parts.

- Suction and discharge connections should be flexible connections (such as hose), not rigid piped, and should be compatible with the substance being pumped.

▲ **CAUTION:** Prevent unnecessary damage to the pump. Do not allow pump to operate when out of material for long periods of time.

- Disconnect air line from pump when system sits idle for long periods of time.

AIR AND LUBE REQUIREMENTS

▲ **WARNING: EXCESSIVE AIR PRESSURE CAN CAUSE PUMP AND PROPERTY DAMAGE. THE AIR SUPPLY MUST BE LIMITED TO 120 PSIG (8 BAR) MAXIMUM INLET AIR PRESSURE.**

- The air supply line or hose to the pump should be adequately sized to carry a sufficient volume of air to the pump. The material inlet supply tubing should not be too small or restrictive which will inhibit material flow. The outlet material volume is governed not only by the air supply but also by the material volume available at the inlet.
- Air supply provided should be filtered to provide clean dry air. A filter capable of filtering out particles larger than 50 microns should be used on the air supply. In most applications there is no lubrication required other than the "O" ring lubricant which is applied during assembly or repair.
- When lubricated air is necessary, supply the air lubricator with a good grade of SAE 90 wt. non-detergent oil and set the lubricator to a rate not to exceed one drop per minute.

INSTALLATION

IMPORTANT

- The pump must be grounded to prevent static discharge. Grounding may be accomplished through the legs or to the ground lug provided on the pump.
- Notice that the material inlet/outlet manifolds may be removed and rotated 180° to facilitate various mounting applications.
- If the body of the pump must be rotated remove the end covers and manifolds and index it so the bolts line up properly. NOTE: The arrow on the end caps must always point upward for optimum performance.
- When the Diaphragm Pump is used in a force-feed situation it is recommended that a Check Valve be installed at the air inlet to keep material out of air line in the event of diaphragm failure.

INSTALLATION CONTINUED

- Secure diaphragm pump legs to a suitable surface to insure against damage by excessive vibration.

OPERATING INSTRUCTIONS

- Regulate the air pressure to the pump as low as possible on initial start-up and adjust upward to operating pressure.
- Always flush the pump with a solvent compatible with the material being pumped prior to first use.
- If the material being pumped is subject to setting up, flush the pump with the solvent prior to shutting down.
- Disconnect the air supply from the pump if it is to be inactive for a few hours.

MAINTENANCE

Refer to the part views and descriptions as provided on page 4 through 7 for parts identification and Service Kit information.

- Certain ARO "Smart Parts" are indicated which should be available for fast repair and reduction of down time.
- Service kits are divided to service two separate diaphragm pump functions: 1. AIR SECTION, 2. FLUID SECTION. The FLUID SECTION is divided further to match typical part MATERIAL OPTIONS.
- Provide a clean work surface to protect sensitive internal moving parts from contamination from dirt and foreign matter during service disassembly and reassembly.
- Keep good records of service activity and include pump in preventive maintenance program.
- Before disassembling empty captured material in the outlet manifold by turning the pump upside down to drain material from the pump.

PERFORMANCE DATA

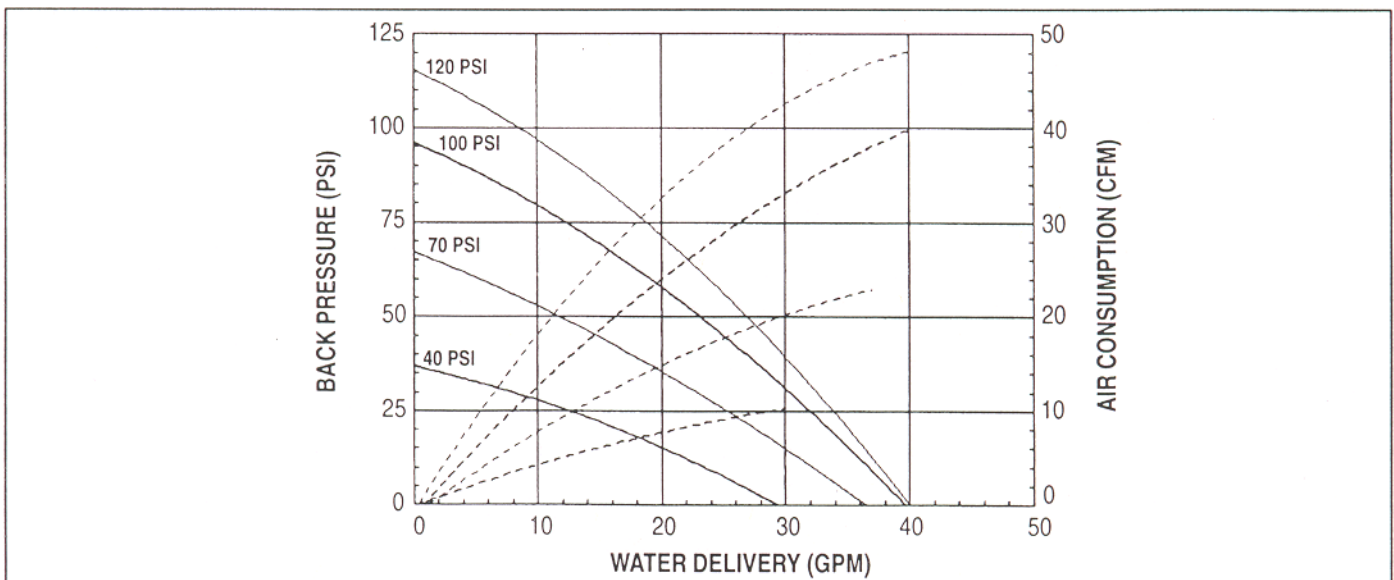

• Viton®, and Hytrel® are trademarks of the DuPont Company. • Kynar® is a trademark of Penwalt Corp.

PARTS LIST / FLUID SECTION

FLUID SECTION SERVICE KITS

- ✓ KIT INCLUDES (ITEMS): (22) Balls, (7) Diaphragms, (2) O-rings, (3) O-rings, (9) Washers and (19) O-Rings.

MATERIAL CODE

[A]=Aluminum
 [B]=Buna "N"
 [BR]=Brass
 [C]=Carbon Steel
 [D]=AcetaL
 [E]=E.P.R.
 [K]=P.V.D.F. (Kynar)
 [N]=Neoprene
 [S]=Steel
 [SS]=Stainless Steel
 [V]=Viton

WETTED COMMON PARTS

			650748	
ITEM	DESCRIPTION (SIZE IN INCHES)	QTY	PART NO.	[MT]
	Fluid Section Service Kit		62164	
□1	Rod	(1)	98724-1	[C]
✓2	"O"Ring (3/4 O.D.)	(1)	Y330-113	[B]
✓3	"O"Ring (5/8 O.D.)	(4)	93002	[E]
5	Plate (Air side) (3-3/8 O.D.)	(2)	93441-2	[S]
□6	Plate (Fluid side) (3-3/8 O.D.)	(2)	93441-1	[SS]
✓7	Diaphragm	(2)	90533-5	[E]
✓9	Washer (5/8)	(2)	93189-1	[SS]
14	Screw	(2)	Y5-85-T	[SS]
15	Fluid Cap	(2)	91045	[SS]
16	Manifold	(2)	91044	[SS]
✓19	"O"Ring (1-9/16 O.D.)	(4)	90534	[E]
21	Seat	(4)	90428	[SS]
✓22	Ball	(4)	90532-5	[E]
26	Bolt (5/16-18 x 1)	(8)	Y6-55-C	[S]
29	Nut (5/16-18)	(16)	Y12-5-C	[S]
43	Ground Lug	(1)	93004	[S]

Service Note: Part No. 98930-T Installation Tool is available separately for use with items (1) and (2).

FLUID SECTION DISASSEMBLY

- Before disassembling, turn the pump upside down to drain any residual material which may be captured in the outlet manifold.
1. Remove the two inlet manifold(s).
 2. Remove the (22) balls, (19) "O"rings, (21) seats.
 3. Remove (15) fluid caps.
 4. Use one wrench to loosen the (14) screw while holding the opposite screw with another wrench. Remove the (14) screws, (9) washers, (3) "O"rings, (6) plates, (7) diaphragms, and (5) plates.
 5. Remove (3) "O"Rings.

NOTE: Do not scratch or mar the surface of (1) diaphragm rod.

FLUID SECTION REASSEMBLY

- Reassemble in reverse order.
- Clean and inspect all parts. Replace worn or damaged parts with new parts as required.
- Lubricate diaphragm rod (1) and (2) "O"ring with Shell Darina Grease 2 lubricant only.

WARNING: DO NOT USE FLUOROCARBON BASED MATERIAL TO REASSEMBLE THIS MODEL.

- Use ARO PN/98930-T Bullet (installation tool) to aid in installation of "O"ring (2) on diaphragm rod (1).
- Be certain (7) diaphragms align properly with (15) fluid caps before making final torque adjustments on bolt and nuts to avoid twisting the diaphragm.
- Re-check torque settings after pump has been re-started and run a while.

COLOR CODE		
MATERIAL	DIAPHRAGM COLOR	BALL COLOR
ACETAL	N/A	ORANGE
BUNA	RED (-)	RED (*)
EPR	BLUE (-)	BLUE (*)
HYTREL	CREAM	TAN
NEOPRENE	GREEN (-)	GREEN (*)
SANTOPRENE	GREEN	N/A
TFE	WHITE	WHITE
URETHANE	N/A	RED
VITON	YELLOW (-)	YELLOW (*)
	(-) STRIPE	(*) DOT

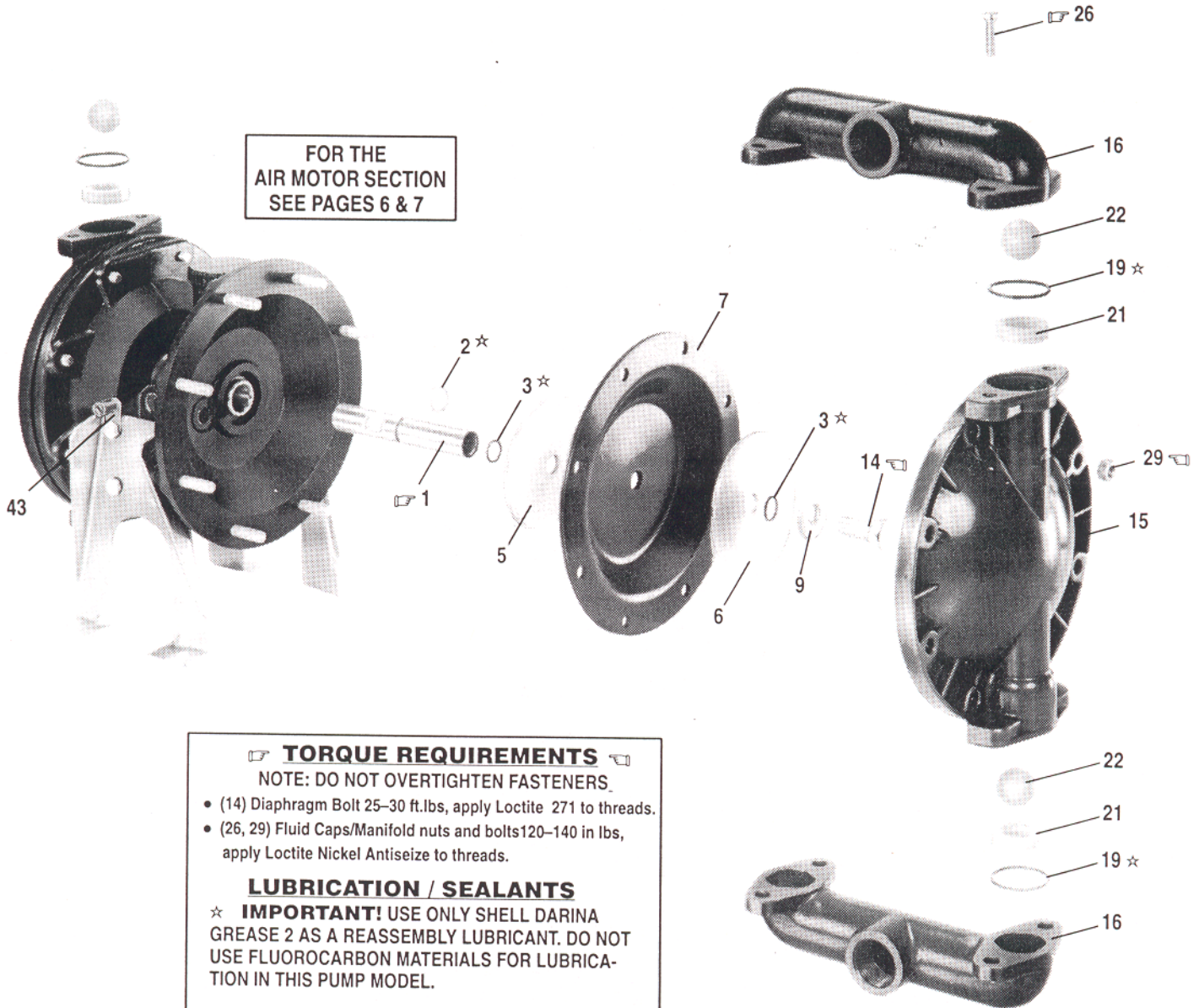

TORQUE REQUIREMENTS
NOTE: DO NOT OVERTIGHTEN FASTENERS.

- (14) Diaphragm Bolt 25–30 ft.lbs, apply Loctite 271 to threads.
- (26, 29) Fluid Caps/Manifold nuts and bolts 120–140 in lbs, apply Loctite Nickel Antiseize to threads.

LUBRICATION / SEALANTS
☆ **IMPORTANT!** USE ONLY SHELL DARINA GREASE 2 AS A REASSEMBLY LUBRICANT. DO NOT USE FLUOROCARBON MATERIALS FOR LUBRICATION IN THIS PUMP MODEL.

REASSEMBLY TIPS

- (5) & (6) Washer radius is towards Diaphragm.
- (8) I.D. bevel is towards (3) O-ring.

PARTS LIST / AIR SECTION

✓ Indicates parts included in 62163 Air Section Service Kit.

ITEM	DESCRIPTION (Size in Inches)	QTY	PART NO.	[MTL]
101	Motor Body	(1)	93219-1	[A]
□102	O-Ring (1 O.D.)	(1)	Y325-020	[B]
□103	Sleeve	(1)	98722-1	[BZ]
✓104	Retaining Ring, TruArc (13/16 O.D.)	(2)	Y145-25	[S]
105	Cap Screw (1/4-20 x 5/8)	(8)	Y6-42-C	[S]
106	Lockwasher (1/4)	(7)	Y14-416	[S]
107	Leg	(2)	92003	[C]
✓108	Gasket (With Notch)	(1)	92878	[B/NY]
□109	Piston	(1)	92011	[D]
✓110	U-Cup (1-3/8 O.D.)	(1)	Y186-51	[B]
□111	Spool	(1)	93047	[SS]
112	Washer (1.557 O.D.)	(5)	92877	[Z]
✓113	O-Ring (Small) (1-1/4 O.D.)	(5)	Y325-214	[B]
✓114	O-Ring (Large) (1-9/16 O.D.)	(6)	Y325-126	[B]
□115	Spacer	(4)	92876	[Z]
□116	Spacer	(1)	92006	[A]

ITEM	DESCRIPTION (Size in Inches)	QTY	PART NO.	[MTL]
✓117	Gasket	(1)	92004	[B/NY]
118	Pilot Rod	(1)	93309-1	[C]
✓119	O-Ring (3/4 O.D.)	(4)	93075	[U]
120	Spacer	(3)	115959	[Z]
121	Sleeve Bushing	(2)	98723-1	[BZ]
✓122	O-Ring (1/2 O.D.)	(2)	Y330-110	[B]
✓123	Screw (8-32 x 3/8)	(4)	Y154-41	[S]
124	Stud (5/16-18 x 1-3/4)	(16)	92866	[SS]
128	Pipe Plug (1/8)	(1)	Y17-50-C	[S]
201	Muffler	(1)	93110	[P]
✓	Screw (10-32 x 1/4) ITEM (122) (For models built prior to 8-92)	(2)	Y212-101	[S]

AIR MOTOR SECTION SERVICE

Service is divided into two parts – 1.Pilot Valve, 2.Major Valve.

GENERAL REASSEMBLY NOTES:

- Air Motor Section Service is continued from Fluid Section repair.
- Inspect and replace old parts with new parts as necessary. Look for deep scratches on metallic surfaces, and nicks or cuts in "O" rings.
- Take precautions to prevent cutting "O" rings upon installation.
- Do not over-tighten fasteners, refer to torque requirement block on view.

WARNING: DO NOT USE FLUOROCARBON BASED MATERIAL TO REASSEMBLE THIS MODEL.

- Re-torque fasteners following restart.

PILOT VALVE DISASSEMBLY

1. Remove (104) retaining ring.
2. Remove, (123) screws, (122) "O" rings.
3. Remove (118) piston rod, (121) sleeve bushing, (119) "O" rings, and (120) spacers from the (101) motor body.
4. Remove (103) sleeve and (102) "O" ring.

PILOT VALVE REASSEMBLY

1. Replace (102) "O" ring if worn or damaged and reinstall (103) sleeve.
2. Install one of the (121) sleeve bushings, (119) "O" rings, (120) spacers, and the remaining (121) bushing.
3. Carefully push (118) pilot rod into bushings etc. and retain on each end with the two (122) "O" rings, retain with (123) screws.
4. Replace (104) retaining rings.

MATERIAL CODE

[A] = Aluminum	[NY] = Nylon
[B] = Buna -N"	[P] = Polypropylene
[BZ] = Bronze	[S] = Steel
[C] = Carbon Steel	[SS] = Stainless Steel
[D] = Acetal	[U] = Polyurethane
	[Z] = Zinc

MAJOR VALVE DISASSEMBLY

1. Remove (107) legs, (108) and (117) gaskets.
2. On the side opposite the air inlet, push on the inner diameter (111) spool. This will force the (109) piston out. Continue pushing the (111) spool and remove. Check for scratches and gouges.
3. Reach into the air section (exhaust side) and remove (116) spacer, (115) spacers, (113) "O" rings, (114) "O" rings, (112) washers, etc. Check for damaged "O" rings.

MAJOR VALVE REASSEMBLY

NOTE: Replace worn parts as necessary. Lubricate "O" ring with Shell Darina Grease 2 when reassembling.

1. Replace (112) washer, (114) "O" ring, (113) "O" ring onto (115) spacer and insert etc.

NOTE: Be careful to orient spacer legs away from blocking internal parts.

2. Lubricate and carefully insert (111) spool.
3. Install (117) gasket and (107).
4. Lubricate and install (110) packing cup and insert (109) piston into (air inlet side) cavity, the (110) packing cup lips should point outward.
5. Install (108) gasket and replace (107).

MAJOR VALVE

See cross section detail Figure 3.

IMPORTANT
BE CERTAIN TO ORIENT (115) SPACER LEGS
AWAY FROM BLOCKING INTERNAL PORTS
WHEN REASSEMBLING AIR SECTION.

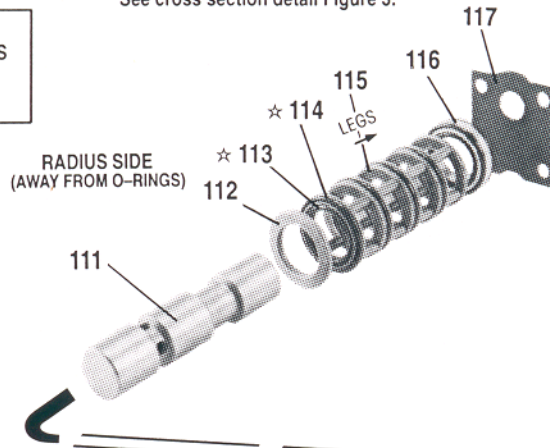
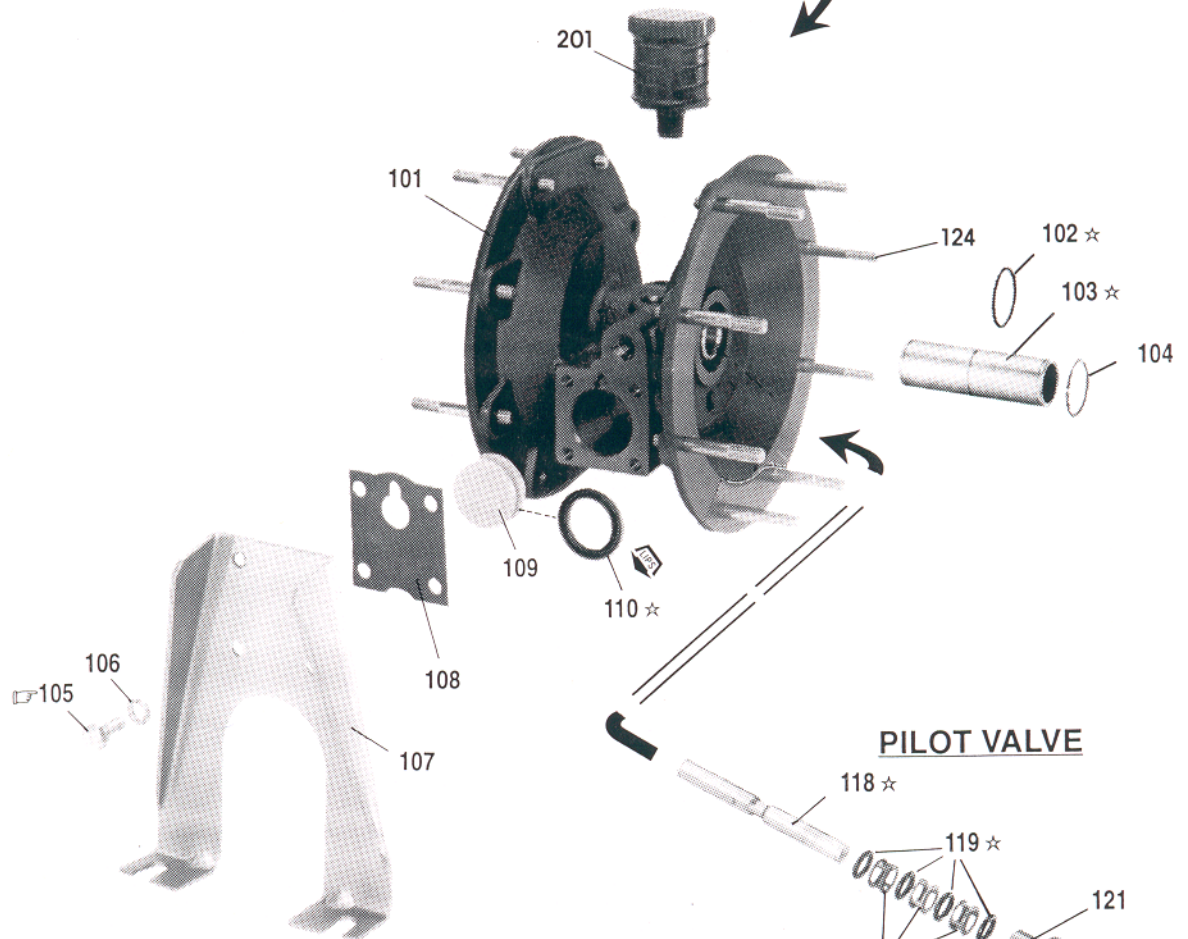

FIGURE 2



MAJOR VALVE CROSS SECTION DETAIL

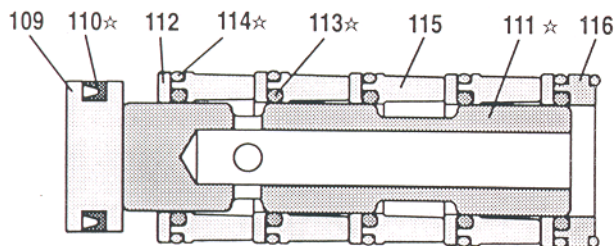

FIGURE 3

TORQUE REQUIREMENTS
NOTE: DO NOT OVERTIGHTEN FASTENERS
(105) 40-50 in. lbs., apply Loctite Nickel Antiseize to threads.

LUBRICATION / SEALANTS
★ **IMPORTANT!** USE ONLY SHELL DARINA GREASE 2
AS A REASSEMBLY LUBRICANT. DO NOT USE FLUOROCAR-
BON MATERIALS FOR LUBRICATION IN THIS PUMP MODEL.
◆ Apply Loctite 271 to threads.

TROUBLE SHOOTING

Product discharged from exhaust outlet.

- Check for diaphragm rupture.
- Check tightness of diaphragm nut.

Air bubbles in product discharge.

- Check connections of suction plumbing.
- Check "O" rings between intake manifold and fluid caps.
- Check tightness of diaphragm nut.

Low output volume, erratic flow, or no flow.

- Check air supply.
- Check for plugged outlet hose.
- Check for kinked (restrictive) outlet material hose.
- Check for kinked (restrictive) or collapsed inlet material hose.
- Check for pump cavitation – suction pipe should be sized at least as large as the inlet thread diameter of the pump for proper flow if high viscosity fluids are being pumped. Suction hose must be a non-collapsing type, capable of pulling a high vacuum.
- Check all joints on the inlet manifolds and suction connections. These must be air tight.
- Inspect the pump for solid objects logged in the diaphragm chamber or the seat area.

DIMENSIONAL DATA

(Dimensions shown are for reference only, they are displayed in inches and millimeters (mm).)

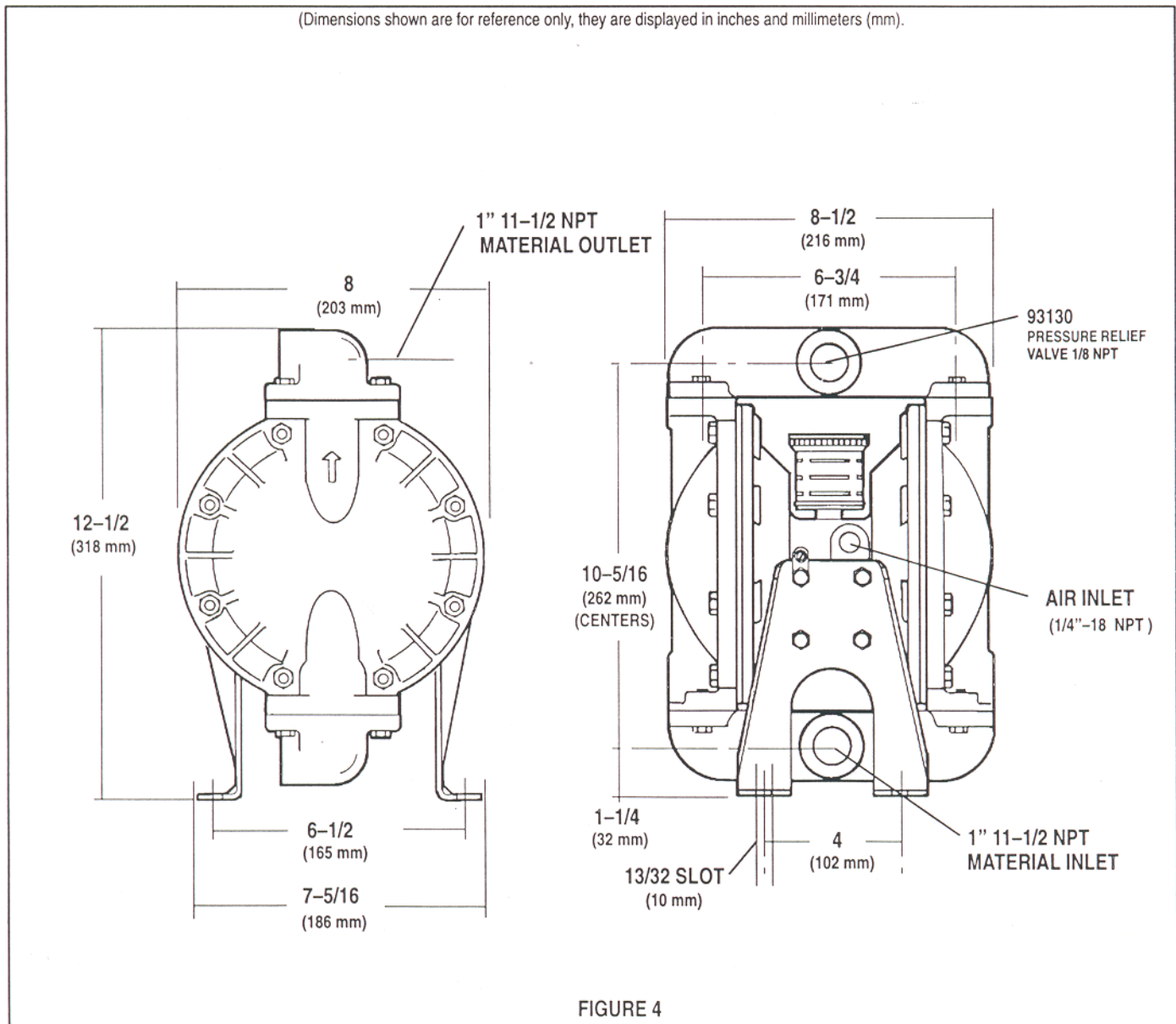

FIGURE 4



Part of worldwide Ingersoll-Rand

Free Manuals Download Website

<http://myh66.com>

<http://usermanuals.us>

<http://www.somanuals.com>

<http://www.4manuals.cc>

<http://www.manual-lib.com>

<http://www.404manual.com>

<http://www.luxmanual.com>

<http://aubethermostatmanual.com>

Golf course search by state

<http://golfingnear.com>

Email search by domain

<http://emailbydomain.com>

Auto manuals search

<http://auto.somanuals.com>

TV manuals search

<http://tv.somanuals.com>