

OPERATOR'S MANUAL

66243-X

INCLUDING: SERVICE KIT, TROUBLESHOOTING, PARTS LIST,
DISASSEMBLY AND ASSEMBLY

RELEASED: 7-7-90
REVISED: 6-4-10
(REV. F) IPP

CHOP-CHECK STYLE LOWER PUMP END ALSO COVERS 637071-XXX SERVICE KIT

**IMPORTANT: READ THIS MANUAL CAREFULLY BEFORE INSTALLING,
OPERATING OR SERVICING THIS EQUIPMENT.**

LOWER PUMP END OPTION DESCRIPTION CHART*

66243-XXX

(PACKINGS ARE UPPER AND LOWER UNLESS NOTED)

PACKING MATERIAL

1 THIOKOL LEATHER ⚠	G UHMW-PE/LEATHER STAG'D
3 GLASS FILLED PTFE	P UHMW-PE/PTFE STAG'D (UPPER)
5 PTFE(GF)/LEATHER STAG'D (UPPER)	UHMW-PE (LOWER)
GLASS FILLED PTFE (LOWER) ⚠	R PTFE/UHMW-PE STAG'D (UPPER)
C UHMW-PE	PTFE (LOWER)
D UHMW-PE/LEATHER STAG'D (UPPER)	
LEATHER (LOWER) ⚠	

⚠ AS OF MAY 15, 1995 NO LONGER AVAILABLE



SPRING ARRANGEMENT

- 1 COIL SPRING. ⚠
- 4 WAVE SPRING
- 5 COMPOSITE SPRING W/ADJ P'KG NUT ⚠

PLUNGER TYPE

- 3 HD SS W/HD CHROME PLATING
- 7 THREADED PLUNGER (LG MOTORS)

* NOT ALL MODEL COMBINATIONS ARE AVAILABLE, REFER TO PUMP MODEL MANUAL (650XXX-XXX) FOR "ACTIVE" MODELS.

SERVICE KITS

- Use only genuine ARO replacement parts to assure compatible-pressure rating and longest service life.
- 637071-XXX for general repair of 66243-XXX Lower Pump End.

GENERAL DESCRIPTION

LOWER PUMP END

⚠ WARNING DO NOT EXCEED MAXIMUM OPERATING PRESSURE AS INDICATED ON PUMP MODEL PLATE

⚠ WARNING REFER TO GENERAL INFORMATION SHEET FOR ADDITIONAL SAFETY PRECAUTIONS AND IMPORTANT INFORMATION. (See the pump model manual for the proper Form No.)

- This LOWER PUMP END MANUAL is one of four documents needed to properly support an ARO pump model. Ref: Part A. 650XXX-XXX-X MODEL (OPERATOR'S) MANUAL, Part B. GENERAL INFORMATION, Part C. MOTOR (OPERATOR'S) MANUAL, Part D. LOWER PUMP END (OPERATOR'S) MANUAL. These forms are available from the factory if needed.
- The Chop-Check design provides for easy priming of the lower foot valve. The double acting feature is standard in all ARO industrial pumps, material is delivered to the pump discharge outlet on both the up and down stroke.

PUMP RATIO X REGULATED = MAXIMUM FLUID PRESSURE PRESSURE

- The pump ratio is an expression of the relationship between the air motor area and the lower pump end area. EXAMPLE: When 150 PSI (10.3 Bar) air pressure is supplied to the pump motor on a 3:1 ratio pump, the lower pump end will develop a maximum of 450 PSI (31 Bar) fluid pressure (at no flow). As the fluid control is opened, the flow rate will increase as the motor cycle rate increases to keep up with the demand.
- Operating at excessive pressures will shorten the life of the pump.

TROUBLE SHOOTING CHOP-CHECK PUMPS

Lower Pump End Problems

- No material at outlet. (Pump continually cycles.)
Check material supply, disconnect or shut off the air supply and replenish the material, reconnect.
- Material on one stroke only. (fast downstroke.)
The lower check may not be seating in the foot valve. (See lower pump disassembly) Remove the check from the foot valve, clean and inspect the valve seat area. If check or foot valve are damaged, replace.
- Material on one stroke only. (fast upstroke.)
- Check for worn or damaged seals. Replace the seals as necessary.
- Material leakage out of the solvent cup or material appears on the pump plunger rod.
For Models (-X5X Only). Increase the load on the packings by tightening the packing nut.
Check for worn upper packings and replace them as necessary.

INGERSOLL RAND COMPANY LTD

209 NORTH MAIN STREET - BRYAN, OHIO 43506

① (800) 495-0276 • FAX(800) 892-6276

www.ingersollrandproducts.com

© 2010

Download from Wwww.Somanuals.com. All Manuals Search And Download.

ARO

IR Ingersoll Rand
Industrial Technologies

PACKING OPTIONS AND SERVICE KITS

LOWER PUMP Popular Models	SERVICE KIT	UPPER PACKING			MIDDLE PACKING				LOWER PCKG				
		51 (X) "V" PACKING			52 (2) "V" PKG		55 (X) "V" PACKING		56 (2) "V" PKG		65 (1) "U" CUP		
66243-XXX	637071-XXX	PART NO	(QTY)	[MT'L]	PART NO	[MT'L]	PART NO	(QTY)	[MT'L]	PART NO	[MT'L]	PART NO	[MT'L]
- G1X ☉, - G4X, - G5X ☉	637071-G43, - G47	93454-4	(3)	[UH]	93454-1	[L]	93455-4	(2)	[UH]	93455-1	[L]	90911	[T]
- P1X ☉, - P4X, - P5X ☉	637071-P43, - P47	93454-4	(3)	[UH]	93454-2	[T]	93455-4	(4)	[UH]			90911	[T]
- R1X ☉, - R4X, - R5X ☉	637071-R43, - R47	93454-2	(3)	[T]	93454-4	[UH]	93455-2	(4)	[T]			90911	[T]

(See Page 4 for other Options) ☉ As of May 15, 1995 these models are no longer available/ EXAMPLE: 66243-G17 is replaced by 66243-G47 & Svce kit is 637071-G47

COMMON WETTED PARTS

66243-XXX					66243-XXX				
ITEM	DESCRIPTION	(QTY)	PART NO	[MTL]	ITEM	DESCRIPTION	(QTY)	PART NO	[MTL]
1	Solvent Cup	(1)	66827-1	[CS]	28	Seat	(1)	91734	[SS]
6	Pump Body	(1)	91718	[DI]	30	Rod	(1)	91719	[SS]
7	Gasket	(2)	90320	[Cu]	31	Plate	(1)	93597-1	[SS]
9	Tube	(1)	91843	[SS]	32	Nut	(1)	Y171-7-C	[SS]
10	Tie Rod	(3)	91725	[CS]	33	Button	(1)	93596-1	[SS]
11	Nut	(3)	Y11-110-N	[CS]	34	Rod (-XX3 Only)	(1)	91735	[SS]
15	Foot Valve Body	(1)	91730	[CS]	34	Rod (-XX7 Only)	(1)	92228-1	[SS]
21	Body	(1)	90916	[SS]	35	Wavy Washer ☉	(2)	91745	[CS]
22	Seat	(1)	91716	[SS]	36	Nut	(1)	91732	[CS]
23	Gasket	(2)	91736	[Cu]	37	Snap Ring	(1)	Y147-102	[CS]
24	"O" Ring	(1)	Y325-229	[B]	39	Valve Seat (-XX7 Only)	(1)	92225	[SS]
25	Adapter	(1)	91841	[DI]	58	Washer, F Bkp ○	(1)	91743	[Br]
26	Plunger Rod (-XX3 Only)	(1)	91731-1	[SS]	61	Washer, M Bkp ○	(1)	91744	[Br]
26	Plunger Rod (-XX7 Only)	(1)	92227-1	[SS]					

☉ Use only on -1XX,-AXX,-DXX & -KXX ○ Use only on -1XX, -AXX & -DXX

UPPER PACKING PARTS

COIL SPRING MODELS -X1X ONLY

ITEM	DESCRIPTION	(QTY)	PART NO	[MTL]
41	Spring	(1)	90325	[SS]
50	Washer, F Bkp	(1)	91723	[Br]
53	Washer, M Bkp	(1)	91724	[Br]

UPPER PACKING PARTS

COMPOSITE SPRING MODELS -X5X ONLY

ITEM	DESCRIPTION	(QTY)	PART NO	[MTL]
42	Composite Spring	(1)	66752-101	[SS]
50	Washer, F Bkp	(1)	91723	[Br]

UPPER PACKING PARTS

WAVE SPRING MODELS -X4X ONLY

ITEM	DESCRIPTION	(QTY)	PART NO	[MTL]
43	Wave Spring	(1)	94129	[SS]
53	Washer, M Bkp	(1)	91724	[Br]
115	Washer, F Bkp	(1)	94130	[De]

MIDDLE PACKING PARTS

"V" TYPE MODELS

ITEM	DESCRIPTION	(QTY)	PART NO	[MTL]
47	Wave Spring	(1)	90528	[CS]
54	Washer, F Bkp	(1)	90322	[Br]
57	Washer, M Bkp	(1)	90305	[Br]

-KXX PACKING OPTION CONSISTS OF: 75 Packing Assembly (93451-1), 76 Packing Assembly (93452-1) & 77 Packing Assembly (93453-1).

MATERIAL CODE

[B]=Buna "N"	[Cu]=Copper	[SS]=Stainless Steel
[Br]=Brass	[De]=Delrin	[T]=PTFE
[CS]=Carbon Steel	[DI]=Ductile Iron	[UH]=UHMW-PE
	[L]=Leather	

SERVICE KITS INCLUDE:

"V" Type Models: 7, 23, 24, 37, 51, 52, 55, 56 & 59.

Cup Type Models: 7, 23, 24, 37, 51, 52, 55, 56 & 65.

-K3X Type Models: 7, 23, 24, 37, 75, 76 & 77.

Also in kit: Two Y15-47-C Cotter Pins to connect pump to Air Motor

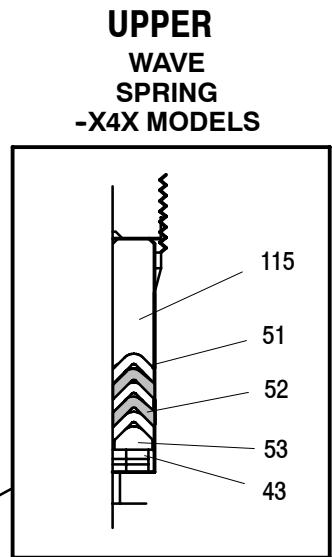
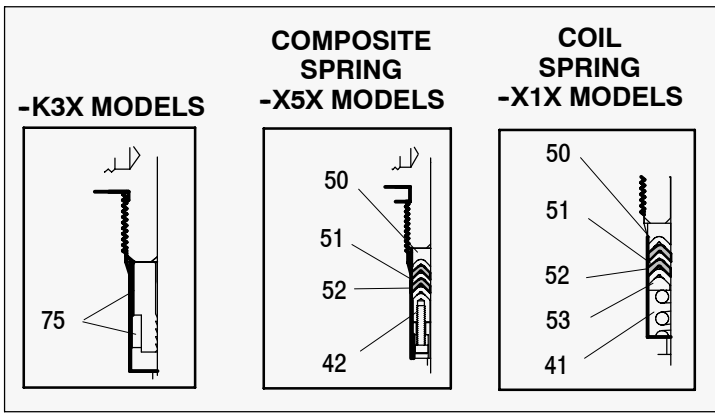

MODELS IN SHADED AREAS NO LONGER AVAILABLE AS OF MAY 15, 1995

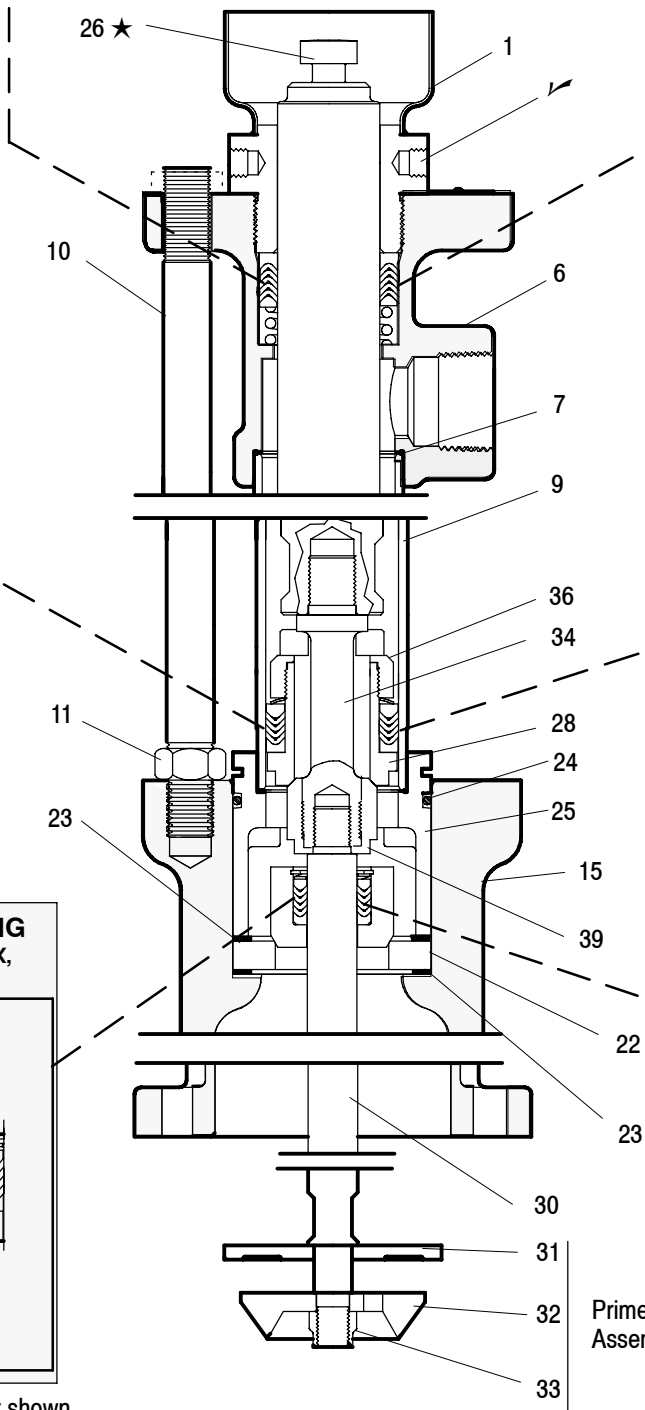
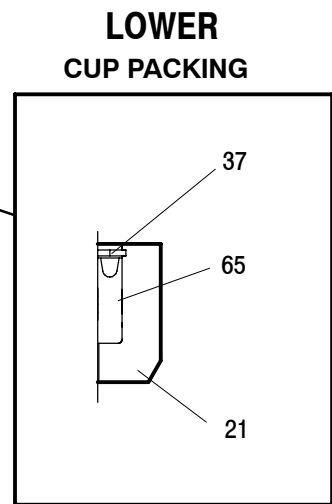
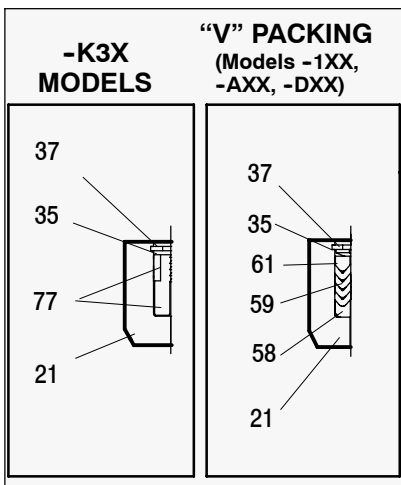
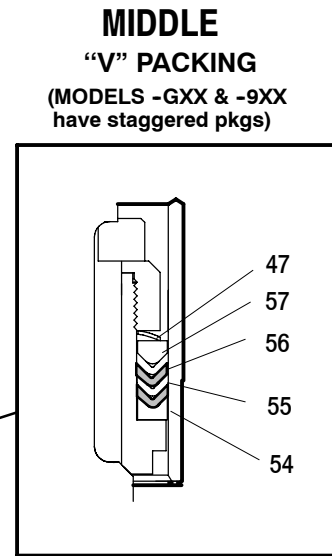
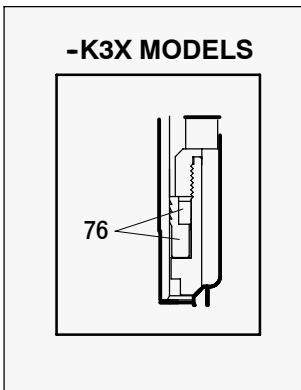

Primer Assembly

★ Threaded Version is not shown

✓ A 93456-1 Rod is included with unit to adjust packing nut/solvent cup.

66243-X

STAGGERED PACKINGS

NOTE: When using "STAGGERED" packings use the shaded position as shown in the views above for the "52" and "56" packings.

PACKING OPTIONS AND SERVICE KITS

LOWER PUMP	SERVICE KIT	UPPER PACKING				MIDDLE PACKING				LOWER PACKING					
		51 (X) "V" PACKING			52 (2) "V" PKG	55 (X) "V" PKG			56 (2) "V" PKG	59 (4) "V" PKG		65 (1) "U"			
		PART #	(QTY)	[MT'L]	PART #	[MT'L]	PART #	(QTY)	[MT'L]	PART #	[MT'L]	PART #	[MT'L]	PART #	[MT'L]
66243-XXX	637071-XXX														
-11X ☉, -15X ☉	637071-G43,-G47	93454-1	(5)	[L]			93455-1	(4)	[L]			93678-1	[L]		
-31X ☉, -343,-35X ☉	637071-G43,-G47	93454-2	(5)	[T]			93455-2	(4)	[T]					90911	[T]
-51X ☉,-55X ☉	637071-G43,-G47	93454-2	(3)	[T]	93454-1	[L]	93455-2	(4)	[T]					90911	[T]
-C1X ☉,-C4X,-C5X ☉	637071-C43,-C47	93454-4	(5)	[UH]			93455-4	(4)	[UH]					90911	[T]
-D1X ☉,-D5X ☉	637071-G43,-G47	93454-4	(3)	[UH]	93454-1	[L]	93455-1	(4)	[L]			93678-1	[L]		

☉ As of May 15, 1995 these models are no longer available.

EXAMPLE: 66243-117 is replaced by 66243-G47 & service kit is 637071-G47.

LOWER PUMP DISASSEMBLY

Note: All threads are right hand.

1. Remove (6) pump body from (9) suction tube, by sliding it off three (10) tie rods.
2. Remove (7) gasket from top of (9) suction tube.
3. Remove three (10) tie rods.
4. Pull (9) suction tube off the MIDDLE packing and valve section and out of (25) adapter.
5. Push (26) plunger rod to expose the primer assembly.
6. Remove (33) nut, (32) valve plate and (31) washer from (30) primer rod.
7. Pull (26) plunger rod and remove MIDDLE packing, valve section and (30) rod from (15) chamber body.
8. Remove (7) gasket out of (25) adapter.
9. With the aid of a flat bladed screwdriver remove (25) adapter, (21) valve body, (22) valve seat and two (23) gaskets out of (15) cham-

- ber body. Use the flat bladed screwdriver to pry on the slot on (25) adapter.
10. Remove (24) "O" Ring from (25) adapter.
11. With retaining ring pliers, remove (37) retaining ring from (21) valve body, then remove the packings out of (21) valve body.
12. Using provided wrench flats, remove (30) rod from (34) valve rod. Again, using wrench flats remove (34) valve rod from (26) plunger rod.

CAUTION: DO NOT mar or damage surfaces of any of these rods.

13. Slide the MIDDLE packing assembly off (34) valve rod.
14. Clamp (34) valve seat in a vise and remove (36) valve seat nut, then remove the MIDDLE packing assembly off (28) valve seat.
15. Remove (1) solvent cup from (6) pump body. Now remove UPPER packing assembly out (6) pump body.

LOWER PUMP REASSEMBLY

Note: All rubber goods and packings should be lubricated with a compatible lubricant prior to assembly.

1. Assemble (21) valve body with LOWER packings. Refer to Packing Options Chart on page 2.
2. Retain LOWER packing assy. in (21) valve body with (37) retaining ring.
3. Assemble (28) valve seat MIDDLE packings. Refer to Packing Options Chart on page 2.
4. Secure the MIDDLE packing assy. with (36) valve seat nut.
5. Slide (21) valve body with LOWER packings onto the end of (30) rod opposite the wrench flats. Install (21) valve body with the beveled end onto rod
6. Screw (30) rod into (34) valve body and tighten.
7. Place (24) "O" Ring on (25) adapter.
8. Slide (25) adapter onto the (34) valve body & (30) rod assy with the wider diameter opening going on first & fit it over (21) body.
9. Slide (28) valve seat and MIDDLE packing assy over (34) valve body. Be sure to place beveled end of (28) valve seat against bevel of (34) valve body.
10. Screw (34) valve body into (26) plunger rod and tighten. Use wrench flats.
11. Place one (23) gasket inside (15) chamber body, followed with (22) valve seat with beveled side up. **NOTE: If stringy or filled material is being pumped, then reverse the (22) valve seat. Next place second (23) brass gasket against top of (22) valve seat.**
12. Place (26) plunger, (28) valve seat and MIDDLE packing assy along with (30) rod & (25) adapter assy into (15) chamber body with the primer rod end going in first. Slide the (25) adapter into place in the (15) chamber body.
13. Place (7) gasket in (25) adapter.

14. Lubricate the MIDDLE packing assy and the inside of (9) suction tube. Carefully slide (9) suction tube over (26) plunger and MIDDLE packing assy into (15) adapter.
15. Install three (10) tie rods.
16. Place (7) gasket on end of (9) suction tube. NOTE: Apply a small amount of grease on gasket to help keep gasket in place.
17. Slide (6) pump body over (26) plunger rod onto (10) tie rods. Seat the (9) suction tube into (6) pump body.
18. Assemble the UPPER packing onto the (26) plunger rod and slide into (6) pump body.
19. Install (1) solvent cup and hand tighten.
20. Push (26) plunger rod to expose (30) rod at bottom of pump. Place (31) washer, (32) plate with beveled edges away from pump and (33) nut onto (30) rod. Tighten (33) nut.
21. Push (30) rod until rod is inside (15) chamber body. Tighten (1) solvent cup.

PN 97999-070

Free Manuals Download Website

<http://myh66.com>

<http://usermanuals.us>

<http://www.somanuals.com>

<http://www.4manuals.cc>

<http://www.manual-lib.com>

<http://www.404manual.com>

<http://www.luxmanual.com>

<http://aubethermostatmanual.com>

Golf course search by state

<http://golfingnear.com>

Email search by domain

<http://emailbydomain.com>

Auto manuals search

<http://auto.somanuals.com>

TV manuals search

<http://tv.somanuals.com>