

Congratulations on your purchase of a high-quality Insignia product. Your NS-CLBT01 represents the state of the art in digital clock radio design and is designed for reliable and trouble-free performance.

Package contents

- Digital Clock Radio with Bluetooth
- AC/DC adapter
- Quick Setup Guide
- User Guide



Top view / controls

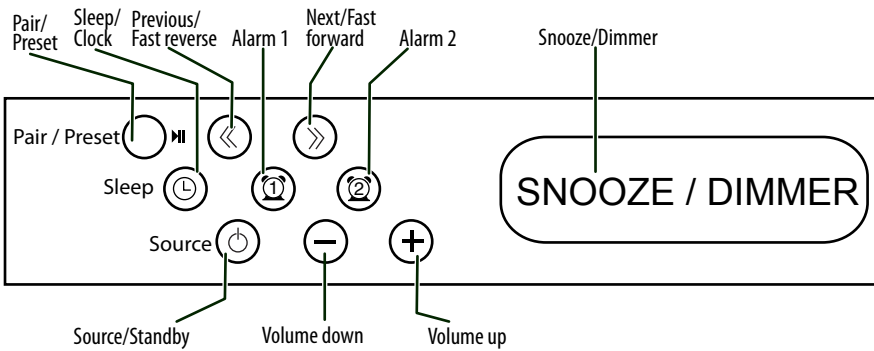

Back view

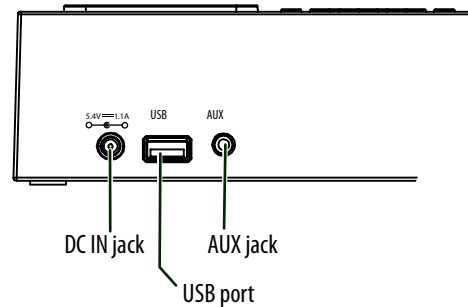

Installing the backup batteries

- 1 While pressing the release latch on the battery compartment cover on the bottom of your radio, lift the cover off your radio.
- 2 Insert two AAA batteries (not included) into the battery compartment. Make sure that the + and - symbols on the batteries align with the + and - symbols inside the compartment.
- 3 Insert the tab on the cover into the slot in the battery compartment, then press down on the cover until it clicks into place.

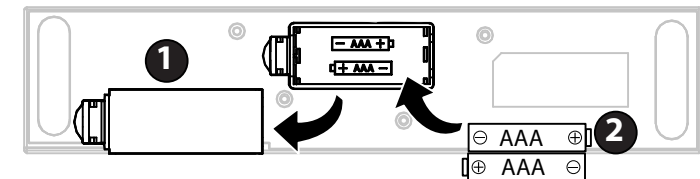



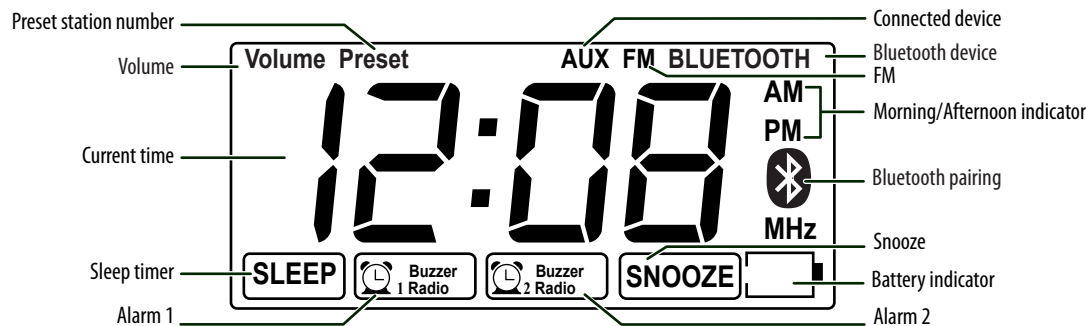







LCD screen















Connecting the AC/DC adapter

- 1 Plug the small connector on the power adapter into the **DC IN** jack on the back of your radio.
- 2 Plug the other connector on the power adapter into a power outlet.















Setting the time







- 1 Press **Sleep**  for about two seconds until the hour digits blink on the LCD.
- 2 Press  or  to increase the hour or press  or  to decrease the hour. Make sure that AM or PM displays correctly.
- 3 Press **Sleep**  again. The minutes digits blink on the LCD.
- 4 Press  or  to increase the minutes or press  or  to decrease the minutes.
- 5 Press **Sleep**  again or to save the time setting and exit time setting mode.

Setting the alarm sound

- 1 Press  (Alarm 1) or  (Alarm 2). The  or  icon blinks on the LCD.
- 2 To use the radio as the alarm sound, press  (Alarm 1) or  (Alarm 2) once. Wait three seconds to save the setting and exit alarm sound setting mode.
OR
To use the buzzer as the alarm sound, press  (Alarm 1) or  (Alarm 2) twice. Wait three seconds to save the setting and exit alarm sound setting mode.
- 3 To completely turn off the alarm, press  (Alarm 1) or  (Alarm 2) repeatedly until the  or  icon disappears from the LCD.

Setting the alarm time

- 1 Press and hold  (Alarm 1) or  (Alarm 2) for about two seconds until the time display blinks on the LCD.
- 2 Press  or  to increase the hour or press  or  to decrease the hour.
- 3 Press  (Alarm 1) or  (Alarm 2) again. The time display blinks on the LCD.
- 4 Press  or  to increase the minutes or press  or  to decrease the minutes.
- 5 Press  (Alarm 1) or  (Alarm 2) again. The **Volume** icon appears in the center of the LCD and the volume digits blinks.

- 6 Press  or  to increase the alarm volume or press  or  to decrease the alarm volume.
- 7 Press  (Alarm 1) or  (Alarm 2) again to save the time setting and exit alarm setting mode.



Turning off your alarm

- Press any button but  (SNOOZE/DIMMER).



Using the snooze feature

- When the alarm sounds, press  (SNOOZE/DIMMER). The alarm turns off for 10 minutes and **SNOOZE** appears on the LCD.









Setting the sleep timer

- Press **Sleep**  repeatedly to select the amount of time you want your radio to wait before it turns off automatically. You can select **15, 30, 45, 60, or 90** minutes. The time you select and the **SLEEP** icon appear on the LCD.
- To turn off the sleep timer, press **Sleep**  repeatedly until **00** appears and the **SLEEP** icon disappears.

Connecting an audio device

- 1 Plug an audio cable with a 3.5 mm connector (not included) into the **AUX IN** jack on the back of your radio and into the audio out jack on your audio device.
- 2 Press **Source**  to turn on your radio, then press **Source**  repeatedly until **AUX** appears on the LCD.
- 3 Use the controls on the audio device to control playback.







Playing your radio

- 1 Make sure that you have connected the AC power adapter.
- 2 Press **Source** . Your radio turns on.
- 3 Press  or  to manually select a radio frequency.
OR
Press and hold  or  to automatically tune to the next lower or higher radio station.
- 4 Press  or  to increase or decrease the volume.
- 5 To turn off your radio, press and hold **Source**  for two seconds.







Playing audio from a Bluetooth device

Notes:

- Your Bluetooth device must be within 33 feet (10 meters) of your radio.
- If you turn off your Bluetooth device or move it too far from your radio, the pairing connection is lost. When you move the last connected device within the radio's range, the pairing connection is restored.

- 1 Make sure that your radio is turned on. Press **Source**  to turn on your radio, then press **Source**  repeatedly until **Bluetooth** appears on the LCD.
- 2 On your radio, press and hold **Pair/Presets**  for six seconds. Your radio enters pairing mode.
NOTE: the clock radio will stay in pairing mode for **30** minutes
- 3 Make sure that your Bluetooth device is turned on and within 33 feet (10 meters) of your radio.
- 4 On your Bluetooth device, start pairing mode and select NS-CLBT01-B.
See instructions that came with your Bluetooth device.
 - If your Bluetooth device is not turned on or is too far away from your radio, the  icon on the LCD blinks every two seconds.
 - While your radio is pairing with your Bluetooth device, the  icon on the LCD blinks twice a second.
 - When pairing is complete, the  icon on the LCD lights solid.

To play from a paired Bluetooth device:

- 1 Press **Source**  to turn on your radio, then press **Source**  repeatedly until **Bluetooth** appears on the LCD.
- 2 To control playback:
 - Press  or  to go to the previous or next song.
 - Press and hold  or  to fast reverse or fast forward through the songs on the Bluetooth device.
 - Press **Pair/Presets**  to start or pause playback.

For more information about using your radio, see your *User Guide*.

90-day limited warranty

See your *User Guide* or visit www.insigniaproducts.com for details.

© 2013 BBY Solutions, Inc. All rights reserved.

Free Manuals Download Website

<http://myh66.com>

<http://usermanuals.us>

<http://www.somanuals.com>

<http://www.4manuals.cc>

<http://www.manual-lib.com>

<http://www.404manual.com>

<http://www.luxmanual.com>

<http://aubethermostatmanual.com>

Golf course search by state

<http://golfingnear.com>

Email search by domain

<http://emailbydomain.com>

Auto manuals search

<http://auto.somanuals.com>

TV manuals search

<http://tv.somanuals.com>