



KONICA MINOLTA

The essentials of imaging

Di2510/Di3010/Di3510

Advanced Information

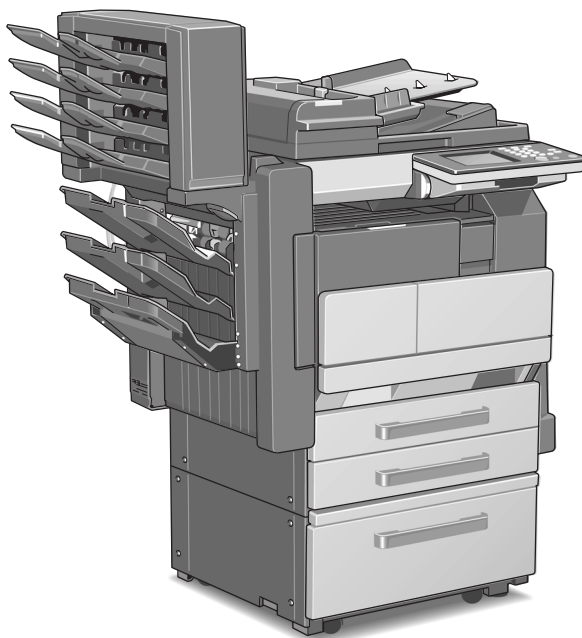

DiALTA

Contents

1 Introduction

1.1	We Want You to Be a Satisfied Customer	1-1
1.2	Explanation of Manual Conventions	1-2
1.3	Explanation of Basic Concepts and Symbols	1-3
	Paper Feeding	1-3
	“Width” and “Length”	1-3
	Paper Orientation	1-4
	Portrait and Landscape	1-4
	Display Icons	1-5
	Paper Supply Icons	1-5
1.4	Energy Star®	1-6
	What is an ENERGY STAR® Product?	1-6
1.5	Components and Their Functions	1-7
1.6	Part Names and Their Functions	1-11
	Copier	1-11
	Options	1-14

2 Safety Information

2.1	Warning and Precaution Symbols	2-1
2.2	Meaning of Symbols	2-1
	WARNING	2-2
	CAUTION	2-3
2.3	Precautions for Routine Use	2-4
2.4	User Instructions	2-5
	CE Marking (Declaration of Conformity)	2-5
	For New Zealand Users	2-5
2.5	Laser Safety	2-6
	Internal Laser Radiation	2-6
	CDRH Regulation	2-7
	For European Users	2-7
	For Denmark Users	2-7
	For Finland, Sweden Users	2-8
	For Norway Users	2-8
	Laser Safety Label	2-9
	Ozone Release	2-9
	Acoustic Noise	2-9

2.6	Installation Precautions	2-10
	Installation Site	2-10
	Power Source	2-10
	Space Requirements	2-11
2.7	Operation Precautions	2-12
	Operating environment	2-12
	Proper use	2-12
	Transporting the copier	2-14
	Care of copier supplies	2-14
	Storage of copies	2-14
2.8	Legal Restrictions on Copying.....	2-15

3 Available Features

3.1	Useful Operations.....	3-1
	Copying a Book or Magazine.....	3-1
	Copying to Form a Booklet	3-4
	Automatically Stapling Pages While Copying	3-6
	Printing Multiple Copies of Tickets	3-8
	Copying While Erasing an Area Around the Document	3-12
	Reducing Paper Usage.....	3-15
	Reducing Electricity Usage	3-17

4 Before Making Copies

4.1	Names of Control Panel Parts and Their Functions.....	4-1
4.2	Checking the Settings.....	4-3
	To check the settings	4-3
	To change the settings.....	4-4
4.3	User Accessibility Operations.....	4-5
	To change the screen display setting ("Screen Mode" function)	4-6
	To change the key settings ("Key Speed Settings" function)	4-7
	To change the auto panel reset time ("Confirming Screen" function)	4-8
	To change the display time for the "The job is accepted." screen ("Notification Screen" function).....	4-9
	To change the volume of touch panel beeps and alarms ("Sound Setting" function)	4-10
4.4	Enlarging the Touch Panel Screens	4-11
4.5	Turning the Copier On and Off.....	4-12
	To turn on the copier.....	4-12
	When the copier is turned on	4-12
	To turn off the copier.....	4-13

	When the copier is turned off.....	4-13
	Auto Panel Reset.....	4-14
	Energy Save Mode.....	4-14
	Sleep Mode.....	4-15
4.6	Adjusting the Angle of the Control Panel.....	4-16
4.7	Using the Touch Panel.....	4-17
	Description of the Touch Panel.....	4-17
	Default Settings.....	4-17
	Operating the Touch Panel.....	4-18
	Description of the Screens.....	4-19
	Job List Screen.....	4-20
	To check the status of a job.....	4-21
	To check the printing order.....	4-22
	To check/delete listed items from the Print screen.....	4-23
	Memory Recall.....	4-24
	To use the memory recall feature.....	4-25

5 Basic Copy Operations

5.1	Making Basic Copies.....	5-1
5.2	Stopping Copying.....	5-3
	To stop/restart/delete a copy job.....	5-3
5.3	Interrupting a Copy Job.....	5-4
	To interrupt copying.....	5-4
5.4	Making Copies Using Accounts.....	5-5
	Using the “Copy Track Mode” Parameter.....	5-5
	To make copies when accounts are specified.....	5-5

6 Auxiliary Functions

6.1	“Cover Mode” Function.....	6-1
	Adding Cover Pages.....	6-1
	To make settings for the “Cover Mode” function.....	6-3
6.2	“Page Insertion” Function.....	6-4
	Inserting Pages (Interleaves) Between Copies.....	6-4
	To make settings for the “Page Insertion” function.....	6-5
6.3	“OHP Interleaving” Function.....	6-6
	Inserting Pages Between Copies of Transparencies.....	6-6
	To make settings for the “OHP Interleaving” function.....	6-7
6.4	“File Margin” Function.....	6-8
	Making Copies With Binding Margins.....	6-8
	To make settings for the “File Margin” function.....	6-9

6.5	“Edge/Frame Erase” Function	6-10
	Erasing Sections of Copies	6-10
	To make settings for the “Edge/Frame Erase” function	6-11
6.6	“Image Repeat” Function	6-12
	Printing Multiple Copies of the Same Document Page on One Sheet	6-12
	To make settings for the “Image Repeat” function	6-12
6.7	“Distribution #” Function.....	6-14
	Printing Distribution Numbers on Sets of Copies	6-14
	To make settings for the “Distribution #” function	6-14
6.8	“Watermark” Function	6-16
	To make settings for the “Watermark” function	6-16
6.9	“Image Stamping” Function	6-17
	To make copies using the “Image Stamping” function	6-17
6.10	“Black-White Reverse” Function	6-19
	Reversing White- and Black-Colored Areas of Copies	6-19
	To set the “Black-White Reverse” function	6-19
6.11	“Separate Scan” Function	6-20
	Scanning a Document in Separate Batches	6-20
	To make copies using the “Separate Scan” function	6-20

7 Utility Mode Operations

7.1	Utility Mode Screens	7-1
	Utility screen	7-1
	User’s Choice screen	7-1
	Meter Count screen	7-2
	Copy Job Program Recall screen	7-2
	User Management screen.....	7-2
	Administrator Management screens	7-3
7.2	User’s Choice Functions	7-4
7.3	Changing Default Settings.....	7-6
	To set the “Memory Recall” function	7-6
	To set the “Mixed Original Detection” function.....	7-7
	To set the “Language Selected for LCD” function.....	7-8
	To set the “Original > Copy Default” function.....	7-9
	To set the “Auto Paper/Auto Size” function.....	7-10
	To set the “Drawer Priority” function	7-11
	To set the “Special Paper” function.....	7-12
	To set the “Multiple-in-1 and Booklet Copy Zoom” function.....	7-14
	To set the “Energy Save Mode” function	7-15
	To set the “Sleep Mode Setting” function.....	7-16

	To set the “LCD Back-light Off” function.....	7-17
	To set the “Auto Panel Reset” function.....	7-18
	To set the “Plug-In Counter, ID key Reset” function.....	7-19
	To set the “4in1 Copy Order” function	7-20
	To set the “Density Priority” function	7-21
	To set the “Default Copy Output Levels” function.....	7-22
	To set the “Printing Density” function	7-23
	To set the “Output Priority” function.....	7-24
	To set the “Intelligent Sorting” function.....	7-25
	To set the “Output Tray” function (optional).....	7-26
	To set the ““Small” Originals” function	7-27
	To set the “Scanner Dry” function.....	7-28
	To set the “Crease/Center Staple” function (Only when the finisher or saddle kit are installed).....	7-29
	To set the “Density (ADF only)” function (Only when the duplexing document feeder is installed)	7-30
7.4	Registering an Image Stamp.....	7-31
	To register an image stamp.....	7-31
7.5	Viewing Counters (“Meter Count” Function).....	7-33
	To view the counters	7-33
7.6	Using Copy Programs	7-34
	To store a copy program	7-34
	To delete a copy program.....	7-35
	To use a copy program.....	7-36
7.7	User Management Functions	7-37
	To adjust beep volumes (“Confirmation Beep” and “Alarm Volume” functions).....	7-37
	To clean the touch panel (“Panel Cleaning” function)	7-38
	To dehumidify the duplexing document feeder (“Dehumidify” function)	7-39
	To replenish the toner (“Toner Replenisher” function).....	7-40

8 Administrator Management Operations

8.1	Administrator Management Screens.....	8-1
	To display the Administrator Management screens	8-1
8.2	Initial Settings.....	8-3
	Specify the date and time	8-3
	To set the date and time.....	8-3
	Specify the time zone	8-5
	To set the time zone	8-5

8.3	Administrator Settings	8-6
	Changing the administrator access code	8-6
	To set the administrator access code	8-6
	Copy Number Limits	8-8
	To specify the maximum number of copies that can be printed	8-8
	Disable Sleep Mode	8-9
	To disable the Sleep mode	8-9
8.4	Account Management Settings	8-10
	Account Management Mode	8-10
	To set the Account Management Mode	8-11
	Account Information data	8-13
	To print account information data	8-13
	Clear all counters	8-14
	Changing Account Information.....	8-15
8.5	Setting Account Registration	8-16
	Account Registration	8-16
	To register accounts	8-16
	Account Counter	8-19
	To check the number of prints made by each account	8-19
8.6	Setting Machine Access	8-20
	Get Penalty	8-20
	To make settings for the “Get Penalty” function.....	8-20
8.7	Configuring Functions (Soft Switches)	8-21
	Specifying Settings for Resetting Copy Mode with the Duplexing Document Feeder Installed (Mode 429)	8-22
8.8	Removing Penalties	8-23
	Free Penalty.....	8-23

9 Copy Paper

9.1	Paper Specifications	9-1
	Paper Types.....	9-1
	Paper Sizes.....	9-1
	Paper Capacity	9-3
9.2	Unsuitable Paper	9-4
9.3	Print Area	9-5
9.4	Paper Storage	9-5
9.5	Automatically Selecting the Paper Source	9-6
	Operating conditions	9-6
	Order for Selecting Another Paper Drawer	9-6

9.6	Loading Paper	9-7
	Loading Paper Into the 1st/2nd/3rd/4th Paper Drawer	9-8
	Loading Paper Into the Large Capacity Cabinet.....	9-9
	Loading Paper Into the Multiple Bypass Tray	9-10
	To load plain paper.....	9-10
	To load postcards	9-11
	To load envelopes	9-12
	To load overhead projector transparencies	9-13
	To load label sheets	9-13
	To set a non-standard (custom) paper size.....	9-14
	To store a non-standard (custom) paper size.....	9-16
	To select a stored non-standard (custom) paper size	9-18
9.7	Selecting the Paper Setting.....	9-19
	To select paper loaded into a paper drawer	9-19
	To select paper loaded into the multiple bypass tray	9-19

10 Original Documents

10.1	Feeding the Document	10-1
	Using the Duplexing Document Feeder.....	10-1
	Document Types	10-1
	Documents of Uniform Sizes	10-1
	Documents of Mixed Original Detection mode	10-1
	Mixed Width Document Sizes.....	10-2
	Precautions Concerning the Documents	10-3
10.2	Feeding the Document Through the Duplexing Document Feeder	10-4
	Loading the Document	10-4
	To load a document of mixed sizes ("Mixed Orig Detection" function).....	10-6
10.3	Positioning Documents on the Original Glass	10-8
	To position sheet documents.....	10-9
	To position transparent or translucent documents	10-10
	To position books or magazines.....	10-11
10.4	Loading Documents for Specific Applications	10-12
	Description of the Table.....	10-12
	Single-Sided Documents	10-13
	Left-Bound Double-Sided Documents	10-19
	Top-Bound Double-Sided Documents.....	10-25
10.5	Large Documents.....	10-31
	Precautions for A3 L/B4 L Copies	10-31

11 Specifying Copy Settings

11.1 Specifying Finishing Settings	11-1
Available Finishing Settings	11-1
Notes on Using the “Sort” and “Group” Settings	11-4
Shift Sorting	11-4
Crisscross Sorting	11-4
Shift Grouping	11-5
Crisscross Grouping	11-5
To make copies using a stapling setting	11-6
To make copies using the “Hole Punch” setting	11-8
Creasing and Folding	11-9
Notes on the Staple Position	11-10
Notes on the Number of Possible Stapled Sets	11-12
Notes on the Hole Punch Position	11-12
11.2 Specifying a Zoom Setting	11-13
To select a Zoom setting	11-14
Specifying a “Custom Zoom” Setting	11-15
To enter a custom zoom ratio	11-15
To store Custom Zoom and Minimal zoom ratios	11-16
To recall a stored custom zoom ratio	11-16
To specify different vertical and horizontal scaling proportions (“X/Y Zoom” setting)	11-17
11.3 Selecting the Orig. > Copy Settings	11-18
Orig. > Copy Settings	11-18
To specify Orig. > Copy settings	11-21
Copying a Bound Document	11-23
Copying a Book	11-25
Copying Book Pages onto Separate Double-Sided Pages	11-28
Quickly Selecting Default Settings	11-30
11.4 Specifying a Copy Density	11-31
Selecting a Density Setting	11-31
Selecting the “Text” Setting	11-31
Selecting the “Photo” Setting	11-32
Selecting the “Text/Photo” Setting	11-33

12 Touch Panel Messages

12.1 When the Message “Ready to copy Please add toner.” Appears	12-1
12.2 When the Message “Please add toner.” Appears	12-2
To replace the toner bottle	12-2

12.3	When the Message “Stapler empty.” Appears	12-5
	To replace the staple cartridge for finisher	12-5
	To replace the staple cartridge for the saddle kit.....	12-8
12.4	When a Paper Misfeed Occurs	12-11
	Locations of Paper Misfeeds	12-11
	To clear a paper misfeed in the duplexing document feeder..	12-12
	To clear a paper misfeed in the fusing section	12-14
	To clear a paper misfeed in the duplex unit.....	12-18
	To clear a paper misfeed in the multiple bypass tray	12-18
	To clear a paper misfeed in the 1st or 2nd paper drawer	12-19
	To clear a paper misfeed in the 3rd or 4th paper drawer	12-20
	To clear a paper misfeed in the large capacity cabinet	12-21
	To clear a paper misfeed in the built in finisher	12-22
	To clear a paper misfeed in the mail bin kit	12-24
	To clear a paper misfeed in the saddle kit.....	12-26
12.5	When the Message “Cannot Staple.” Appears	12-27
	To clear jammed staples	12-27
12.6	When the Message “Hole Punch collection box is full.” Appears	12-31
	To empty the punch box.....	12-31

13 Troubleshooting

13.1	Main Messages and Their Remedies	13-1
13.2	When Incorrect Copies Are Printed	13-3
13.3	When the Copier Is Not Operating Correctly	13-6

14 Appendix

14.1	Specifications	14-1
	Copier Di2510/Di3010/Di3510	14-1
	Duplexing Document Feeder AFR-19	14-3
	Mixed Width Document Sizes.....	14-3
	Duplex Unit AD-16.....	14-4
	Switchback Unit SB-1	14-4
	Paper Feed Cabinet PF-124.....	14-4
	2Way Paper Feed Cabinet PF-210	14-5
	Large Capacity Cabinet PF-122	14-5
	Built in Finisher FN-117	14-6
	Additional Bin Kit AK-1	14-6
	Mail Bin Kit MK-1	14-7
	Punch Kit PK-6	14-7
	Saddle Kit SK-1	14-7
	Job Separator JS-203.....	14-8

14.2	Care of the Copier	14-9
	Cleaning.....	14-9
	Housing cover	14-9
	Original glass	14-9
	Operation panel	14-9
	Original glass	14-10
14.3	Function Combination Table	14-11
	Function combination codes	14-14
14.4	Paper Size and Zoom Ratio Tables	14-16
	Paper Sizes.....	14-16
	Zoom Ratios.....	14-17
14.5	Consumables	14-20
	Paper	14-20
	Toner Bottle	14-20
	Staple Cartridges	14-21
14.6	Index	14-22

1 Introduction

1.1 We Want You to Be a Satisfied Customer

Thank you for choosing a Konica Minolta Copier System.

To ensure the best performance and effective use of your copier, this manual will provide information on the following topics:

- Getting to Know Your Copier
- Initial Steps . . .
- Customizing Your Copy
- Combining Functions
- Utilities
- Troubleshooting

Please read this manual carefully before using your copier and keep it handy at all times. Store the manual in the holder on the rear side of the copier.

For further information and assistance, please contact:

- your Konica Minolta Technical Representative;

Please keep the serial number (located on the copier's rating plate) and the copier's date of purchase handy to ensure fast, accurate assistance in the event of difficulties.

. . . because we want you to be a satisfied customer.

1.2 Explanation of Manual Conventions

The marks and text formats used in this manual are described below.



WARNING

Failure to observe instructions highlighted in this manner may result in fatal or critical injuries.

→ Observe all warnings in order to ensure safe use of the copier.



CAUTION

Failure to observe instructions highlighted in this manner may result in serious injuries or property damage.

→ Observe all cautions in order to ensure safe use of the copier.



Note*

(*May also appear as “Important” or “Tip”)

Text highlighted in this manner contains useful information and tips to ensure safe use of the copier.

1 The number 1 as formatted here indicates the first step of a sequence of actions.

2 Subsequent numbers as formatted here indicate subsequent steps of a sequence of actions.

? *Text formatted in this style provides additional assistance.*

→ Text formatted in this style describes the action that will ensure the desired results are achieved.

An illustration inserted here shows what operations must be performed.

[Copy] key

The names of keys on the control panel are written as shown above.

1.3 Explanation of Basic Concepts and Symbols

The use of words and symbols in this manual are explained below.

Paper Feeding

During printing, paper is supplied from the right side of the copier and fed into the output tray on top or the output option at the left with the printed surface of the page facing down. The paper feed direction is shown by the arrows in the diagram below.

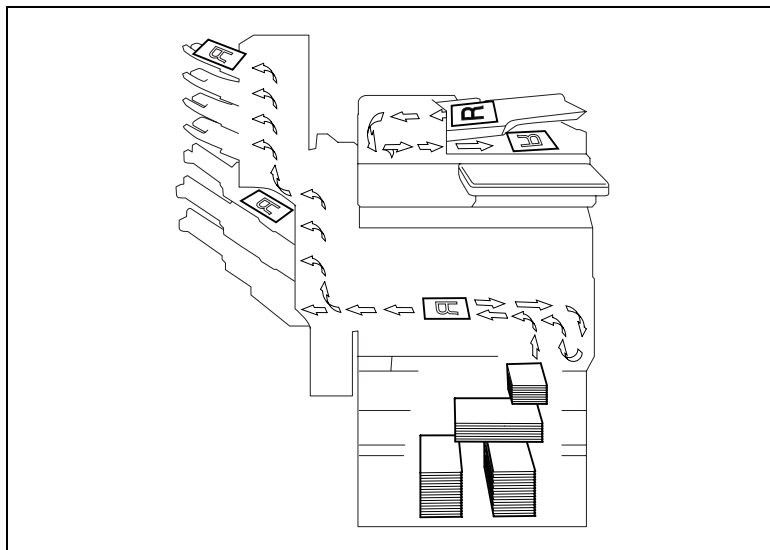

“Width” and “Length”

Whenever paper dimensions are mentioned in this manual, the first value always refers to the width of the paper (shown as “Y” in the illustration) and the second to the length (shown as “X”).

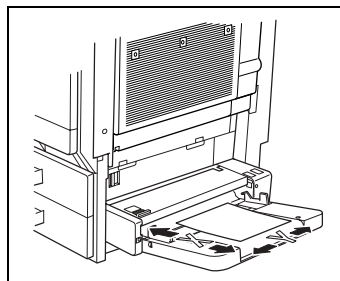

Paper Orientation

Lengthwise ()

If the width (Y) of the paper is shorter than the length (X), the paper has a vertical or portrait orientation, indicated by either “L” or .

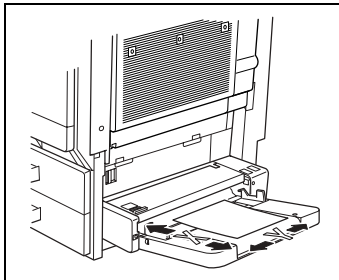

Crosswise ()

If the width (Y) of the paper is longer than the length (X), the paper has a horizontal or landscape orientation, indicated by either “C” or .

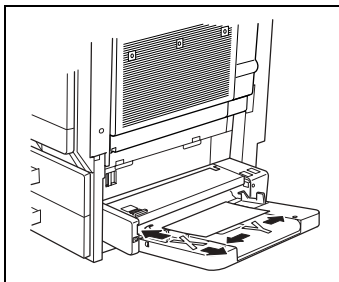

Portrait and Landscape

Portrait

With the “portrait” orientation, the paper is vertical, like a portrait.

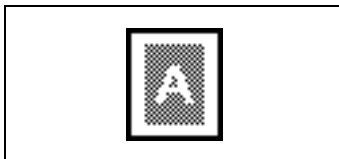

Landscape

With the “landscape” orientation, the paper is horizontal, like a landscape.

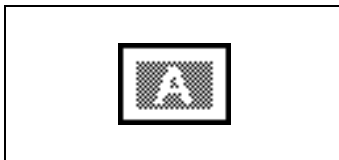

Display Icons

Plain paper

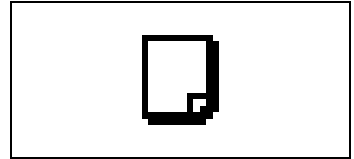

Thick paper

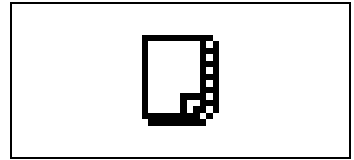

Overhead projector transparencies

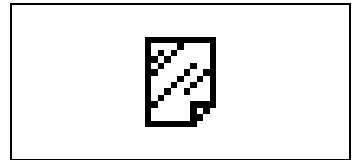

Envelope

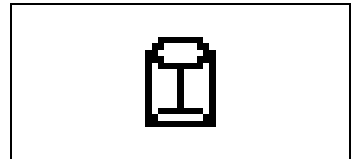

Paper Supply Icons

The icons shown below may appear, indicating that no more paper remains.

The paper is empty.

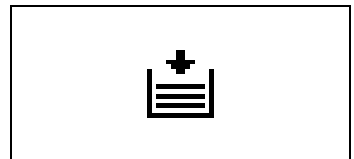

1.4 Energy Star®

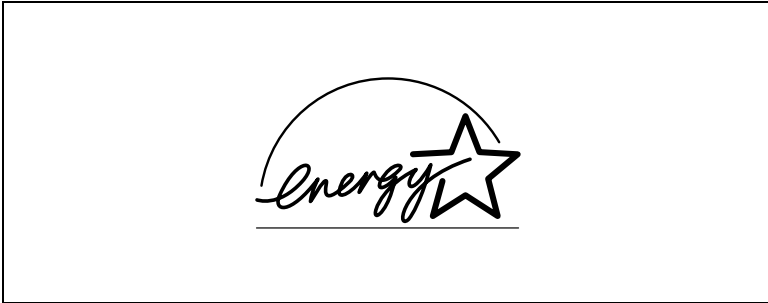

As an ENERGY STAR® Partner, we have determined that this machine meets the ENERGY STAR® Guidelines for energy efficiency.

What is an ENERGY STAR® Product?

An ENERGY STAR® product has a special feature that allows it to automatically switch to a “low-power mode” after a period of inactivity. An ENERGY STAR® product uses energy more efficiently, saves you money on utility bills and helps protect the environment.

1.5 Components and Their Functions

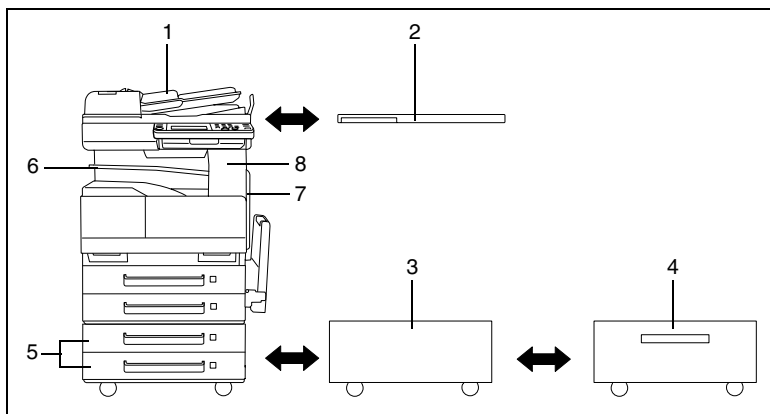

No.	Part Name	Description
1	Duplexing Document Feeder AFR-19 (optional)	Automatically feeds one document sheet at a time for scanning, and automatically turns over double-sided documents for scanning Referred to as the "duplexing document feeder" throughout the manual.
2	Original Cover Kit OC-6 (optional)	Presses down on the loaded document to keep it in place Referred to as the "original cover" throughout the manual.
3	Copy Desk CD-4M (optional)	The copier can be placed on the copy desk. Using the copy desk allows the copier to be set up on the floor. Referred to as the "copy desk" throughout the manual.
4	Large Capacity Cabinet PF-122 (optional)	A large-capacity paper supply cassette that can supply 2,500 sheets of paper. Referred to as the "large capacity cabinet" throughout the manual.
5	2 Way Paper Feed Cabinet PF-210 (optional)	A two-level paper supply tray. Each paper supply tray can hold up to 500 sheets of paper. Referred to as the "paper feed cabinet" throughout the manual.
6	Job Separator JS-203 (optional)	Allows printed pages to be separated Pull the lever when taking out the paper. <ul style="list-style-type: none"> In order to use the job separator, the switchback unit must be installed.
7	Duplex Unit AD-16	Automatically turns the pages over, and prints on both sides. Referred to as the "duplex unit" throughout the manual. When using the duplex unit, the switchback unit is required.
8	Switchback Unit SB-1	When copying to both sides of a page, this turns over the paper. Required when using the duplex unit.

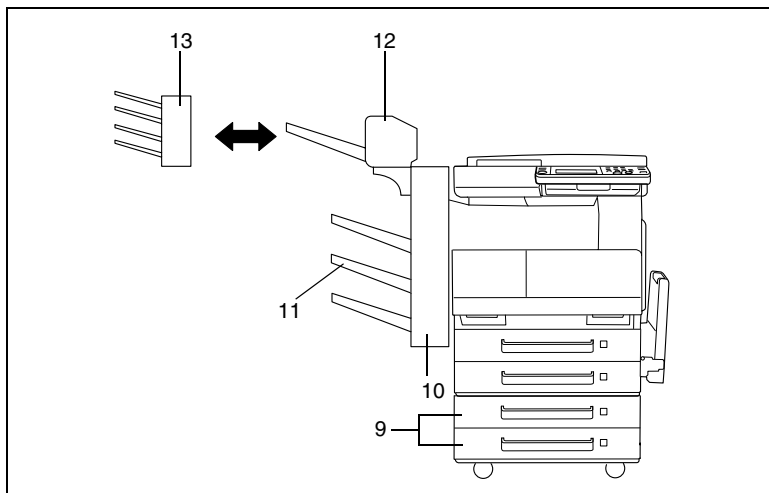

No.	Part Name	Description
9	Paper Feed Cabinet PF-124 (optional)	Equipped with a paper drawer that can supply 500 sheets of paper, for upper paper feed unit only. Referred to as the "paper feed cabinet" throughout the manual.
10	Built in Finisher FN-117 (optional)	Finishes printed pages according to the selected finishing mode (sorting or stapling), then feeds out the pages. Referred to as the "finisher" throughout the manual.
11	Additional Bin Kit AK-1 (optional)	If this option is attached to the finisher, the bins for separating printed pages increases. Referred to as the "3rd paper output tray" throughout the manual.
12	Saddle Kit SK-1 (optional)	If this option is attached to the finisher, stapling, hole-punching, creasing and booklet-printing are available as Finishing settings. Referred to as the "saddle kit" throughout the manual.
13	Mail Bin Kit MK-1 (optional)	If this option is attached to the finisher, the printed pages can be divided and fed into the appropriate bin assigned to a specific individual or group. <ul style="list-style-type: none"> This option can only be used with computer printouts. Referred to as the "mail bin kit" throughout the manual.

No.	Part Name	Description
14	Punch Kit PK-6 (optional)*	If this option is attached to the finisher, hole-punching is possible. Referred to as the "punch kit" throughout the manual.
15	32 MB/64 MB/128 MB Memory M32-4/M64-2/M128-3 (optional)*	Increases the memory of the copier to as much as 192 MB (64 MB standard memory + 32/64/128 MB expanded memory) By expanding the memory, the number of pages that can be stored in the memory can be increased. Referred to as the "expansion memory" throughout the manual.
16	Hard Disk Drive Kit HDD-6 (optional)*	Allows more pages to be stored. Increases the number of pages that can be scanned. Additionally, can scan multiple jobs. <ul style="list-style-type: none"> To install the function expansion Hard Disk Drive Kit HDD-6, optional printer controllers Pi3505e or Pi3505e/PS are required. Referred to as the "hard disk" through out the manual.
17	Printer controller Pi3505e, Pi3505e/PS (optional)*	An internal printer controller. This allows this copier to be used as a computer printer. For more details, refer to the manual of the printer controller.
18	Internet Fax & Network Scan Kit SU-3 (optional)*	An internal Internet Fax & Network Scan Kit. You can use this copier as a network scanner or as an Internet fax machine. For more details, refer to the Scanner Mode User Manual.
19	Network Scan Kit SU-2 (optional)*	An internal Network Scan Kit. You can use this copier as a network scanner. For more details, refer to the Scanner Mode User Manual.
20	Network Interface Card NC-4 (optional)*	Required when using this copier as a printer, scanner, or as an Internet fax machine. For more details, refer to the Scanner Mode User Manual or the Printer Controller Manual.
21	Parallel Interface Kit	When this copier is used as a printer, printing can be performed through a parallel connection (IEEE1284). <ul style="list-style-type: none"> When the Parallel Interface Kit is installed, the optional Printer Controller Pi3505e or Pi3505e/PS and the Network Interface Card NC-4 are necessary.

* The internal options are not shown.

How to use the Job Separator (JS-203)?

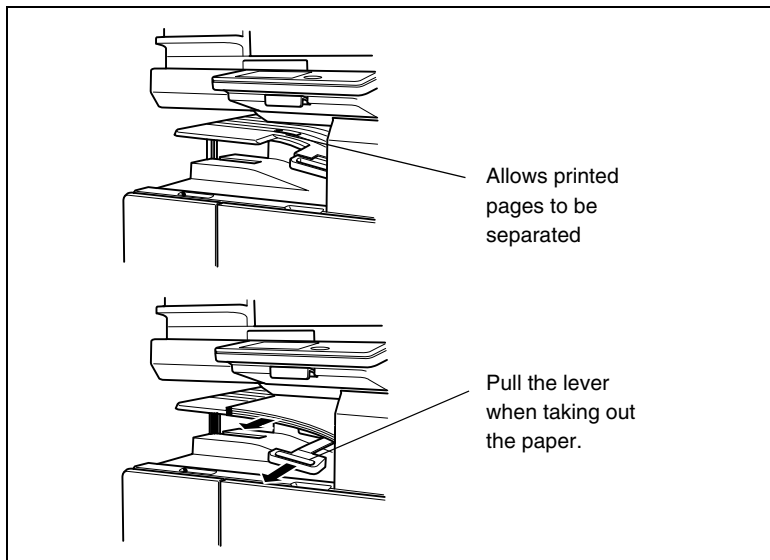

1.6 Part Names and Their Functions

Copier

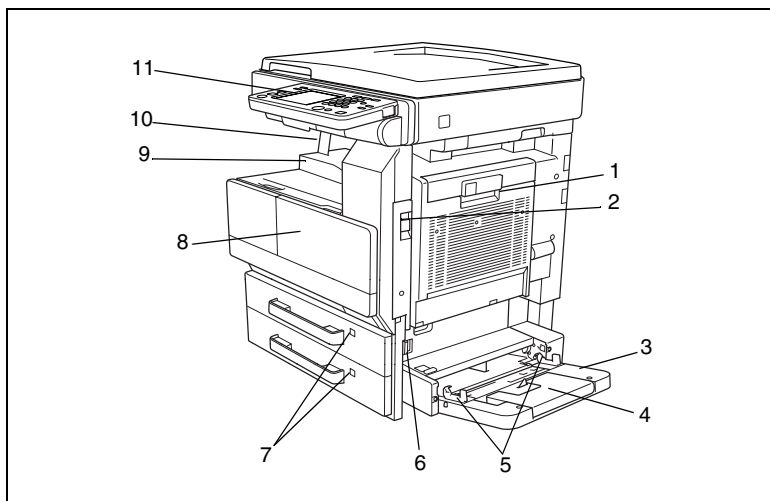

No.	Part Name	Description
1	Right-side door	Opened when clearing paper misfeeds.
2	Right-side door release lever	Used to open the right-side door.
3	Multiple bypass tray	Used for manual feeding paper for making copies and printouts. Can be loaded with 150 sheets of paper. Can be loaded with special paper, see page 9-10
4	Tray extension	Open the tray extension when loading large-sized paper.
5	Paper guide	Adjust to the width of the paper.
6	Release lever	Opened when clearing paper misfeeds.
7	Paper supply indicator	As the amount of paper in the paper drawer decreases, the area that appears in red increases.
8	Front door	Opened when replacing the toner bottle, see page 12-2
9	Paper output tray	Collects printed pages fed out of the copier facing down.
10	Paper stopper	Prevents printed pages from falling out of the paper output tray Used when the optional sorter is installed.
11	Touch panel	Liquid crystal display in the control panel. Used to specify various copy settings and program or change functions.

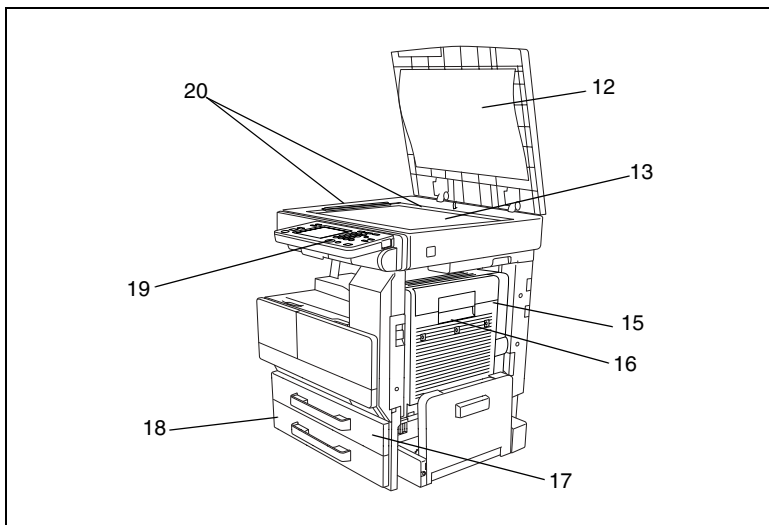

No.	Part Name	Description
12	Document pad	Presses down on the document positioned on the original glass.
13	Original glass	When manually feeding the document, place it on the glass so the document can be scanned. Place the document face down on the glass.
14	Switchback unit *	Built into the printer to turn over the paper when printing double-sided pages.
15	Duplex unit	Turns over printed pages, allowing double-sided pages to be printed automatically. When using the duplex unit, the switchback unit is required. Referred to as the "duplex unit" throughout the manual.
16	Duplex unit door	Opened when clearing a paper misfeed within the duplex unit.
17	1st paper drawer	Holds up to 500 sheets of paper. The paper size can be adjusted freely, see page 9-8
18	2nd paper drawer	Holds up to 500 sheets of paper. The paper size can be adjusted freely, see page 9-8
19	Control panel	Used to start copying or to specify various settings
20	Document scales	Used to align the document

* The internal unit is not shown.

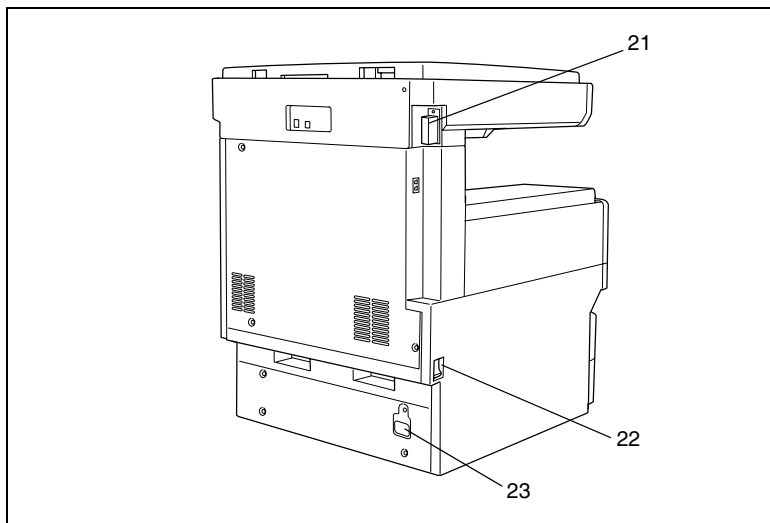

No.	Part Name	Description
21	Duplexing Document Feeder connector	Used for connecting the duplexing document feeder hookup cord.
22	Power switch	Used to turn the copier on and off, see page 4-12
23	Power cord socket	Used for connecting the printer's power cord.

Options

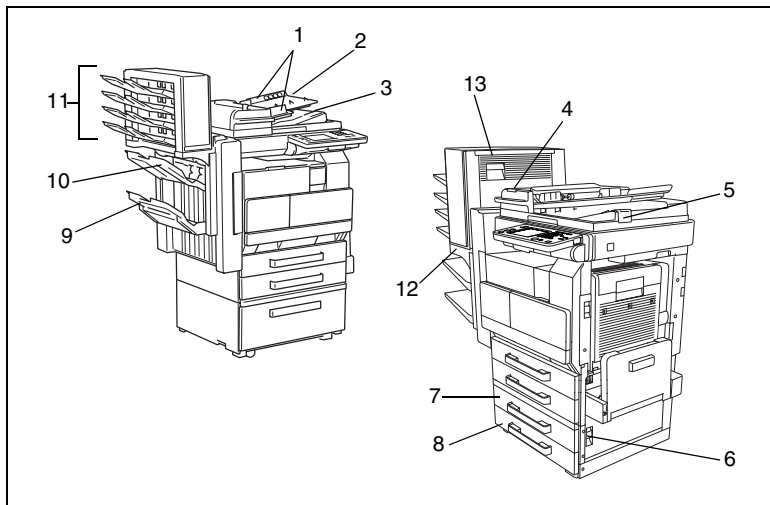

Duplexing Document Feeder

No.	Part Name	Description
1	Document guides	Adjust to the width of the document.
2	Document feed tray	Load the documents to be copied face up.
3	Document output tray	Collects documents that have been copied.
4	Print indicator	Lights up or flashes to indicate the status of the copier.
5	Paper stopper	Prevents the documents from falling out of the document output tray.

Paper Feed Cabinet (PF-124/PF-210)*

No.	Part Name	Description
6	Lower-right door release lever	Used to open the lower-right door.
7	3rd paper drawer	Each drawer can hold up to 500 sheets of paper. The paper size can be adjusted freely.
8	4th paper drawer	

* PF-210: Equipped with a paper drawer that can supply 500 sheets of paper, for upper paper feed unit only.

Built in Finisher (FN-117)

No.	Part Name	Description
9	2nd paper output tray (sorted copy tray)	Collects printed pages that are sorted.
10	1st paper output tray (non-sorted copy tray)	Collects printed pages that are not sorted (made with the "Non-Sort" setting).

Mail Bin Kit (MK-1)

No.	Part Name	Description
11	Mail Bin	Collects copies that are sorted.
12	Output tray cover	Opened when clearing paper misfeeds.
13	Misfeed-clearing door	Opened when clearing paper misfeeds.

Precautions for using the finisher, saddle kit and mail bin kit

- Do not place objects on top of the saddle kit or mail bin kit.
- Do not place objects under the paper output trays of the finisher.

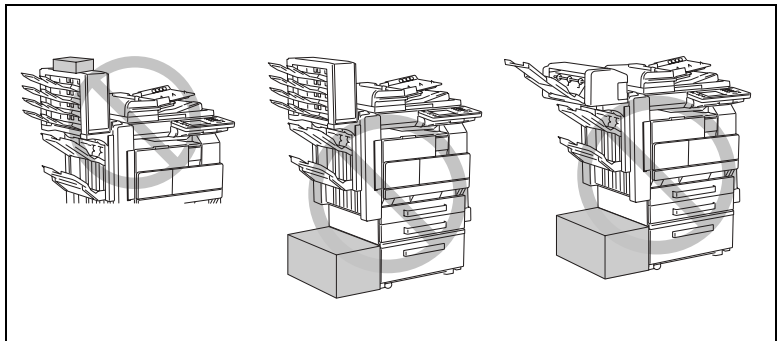

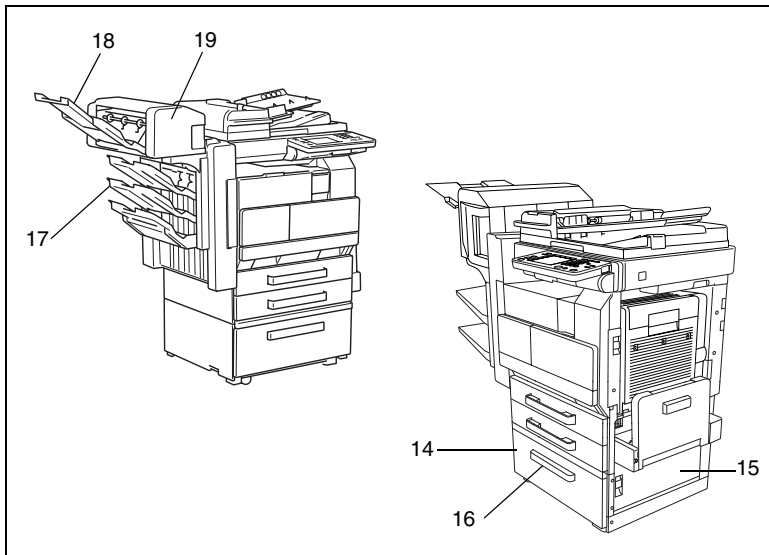

Large Capacity Cabinet (PF-122)

No.	Part Name	Description
14	3rd paper drawer (LCC)	Holds up to 2,500 sheets of paper.
15	Lower-right door	Opened when clearing paper misfeeds.
16	Drawer release button	Pressed when loading paper.

Additional Bin Kit (AK-1)

No.	Part Name	Description
17	3rd paper output tray	Collects printed pages.

Saddle Kit (SK-1)

No.	Part Name	Description
18	Paper output tray	Collects printed pages.
19	Misfeed-clearing door	Opened when clearing paper misfeeds that occurred in the finisher.

2 Safety Information

This section contains detailed instructions on the operation and maintenance of this machine. To achieve optimum utility of this device, all operators should carefully read and follow the instructions in this manual. Please keep this manual in a handy place near the machine.



Please read the next section before using this device. It contains important information related to user safety and preventing equipment problems.

Make sure you observe all of the precautions listed in this manual.

* Ver06

Please note that some parts of the contents of this section may not correspond with the purchased product.

2.1 Warning and Precaution Symbols

 WARNING:	Ignoring this warning could cause serious injury or even death.
 CAUTION:	Ignoring this caution could cause injury or damage to property.

2.2 Meaning of Symbols



A triangle indicates a danger against which you should take precaution.



This symbol warns against cause burns.



A diagonal line indicates a prohibited course of action.



This symbol warns against dismantling the device.











A black circle indicates an imperative course of action.



This symbol indicates you must unplug the device.

 **WARNING**

	<ul style="list-style-type: none"> Do not modify this product, as a fire, electrical shock, or breakdown could result. If the product employs a laser, the laser beam source could cause blindness. Do not attempt to remove the covers and panels which have been fixed to the product. Some products have a high-voltage part or a laser beam source inside that could cause an electrical shock or blindness.
	<ul style="list-style-type: none"> Use only the power cord supplied in the package. If a power cord is not supplied, only use the power cord and plug that is specified in POWER CORD INSTRUCTION. Failure to use this cord could result in a fire or electrical shock. Use the power cord supplied in the package only for this machine and NEVER use it for any other product. Failure to observe this precaution could result in a fire or electrical shock. Use only the specified power source voltage. Failure to do that could result in a fire or electrical shock. Do not use a multiple outlet adapter to connect any other appliances or machines. Use of a power outlet for more than the marked current value could result in a fire or electrical shock.
	<p>Do not unplug and plug in the power cord with a wet hand, as an electrical shock could result.</p>
	<p>Plug the power cord all the way into the power outlet. Failure to do this could result in a fire or electrical shock.</p>
	<ul style="list-style-type: none"> Do not scratch, abrade, place a heavy object on, heat, twist, bend, pull on, or damage the power cord. Use of a damaged power cord (exposed core wire, broken wire, etc.) could result in a fire or breakdown. Should any of these conditions be found, immediately turn OFF the power switch, unplug the power cord from the power outlet, and then call your authorized service representative. Do not use an extension cord, in principle. Use of an extension cord could cause a fire or electrical shock. Contact your authorized service representative if an extension cord is required.
	<p>Do not place a flower vase or other container that contains water, or metal clips or other small metallic objects on this product. Spilled water or metallic objects dropped inside the product could result in a fire, electrical shock, or breakdown.</p> <p>Should a piece of metal, water, or any other similar foreign matter get inside the product, immediately turn OFF the power switch, unplug the power cord from the power outlet, and then call your authorized service representative.</p>
	<ul style="list-style-type: none"> Do not keep using this product, if this product becomes inordinately hot or emits smoke, or unusual odor or noise. Immediately turn OFF the power switch, unplug the power cord from the power outlet, and then call your authorized service representative. If you keep on using it as is, a fire or electrical shock could result. Do not keep using this product, if this product has been dropped or its cover damaged. Immediately turn OFF the power switch, unplug the power cord from the power outlet, and then call your authorized service representative. If you keep on using it as is, a fire or electrical shock could result.
	<p>Do not throw the toner cartridge or toner into an open flame. The hot toner may scatter and cause burns or other damage.</p>



Connect the power cord to an electrical outlet that is equipped with a grounding terminal.

CAUTION



- Do not use flammable sprays, liquids, or gases near this product, as a fire could result.
- Do not leave a toner unit or drum unit in a place within easy reach of children.
Licking or ingesting any of these things could injure your health.
- Do not let any object plug the ventilation holes of this product. Heat could accumulate inside the product, resulting in a fire or malfunction.
- Do not install this product at a site that is exposed to direct sunlight, or near an air conditioner or heating apparatus. The resultant temperature changes inside the product could cause a malfunction, fire, or electrical shock.
- Do not place the product in a dusty place, or a site exposed to soot or steam, near a kitchen table, bath, or a humidifier. A fire, electrical shock, or breakdown could result.
- Do not place this product on an unstable or tilted bench, or in a location subject to a lot of vibration and shock. It could drop or fall, causing personal injury or mechanical breakdown.
- After installing this product, mount it on a secure base. If the unit moves or falls, it may cause personal injury.
- Do not store toner units and PC drum units near a floppy disk or watch that are susceptible to magnetism. They could cause these products to malfunction.



The inside of this product has areas subject to high temperature, which may cause burns. When checking the inside of the unit for malfunctions such as a paper misfeed, do not touch the locations (around the fusing unit, etc.) which are indicated by a "CAUTION HOT" caution label.



Do not place any objects around the power plug as the power plug may be difficult to pull out when an emergency occurs.





The socket-outlet shall be installed near the machine and shall be easily accessible as the power plug may be difficult to pull out when an emergency occurs.



- Always use this product in a well ventilated location. Operating the product in a poorly ventilated room for an extended period of time could injure your health. Ventilate the room at regular intervals.
- Whenever moving this product, be sure to disconnect the power cord and other cables. Failure to do this could damage the cord or cable, resulting in a fire, electrical shock, or breakdown.
- When moving this product, always hold it by the locations specified in the User manual or other documents. If the unit falls it may cause severe personal injury. The product may also be damaged or malfunction.
- Remove the power plug from the outlet more than one time a year and clean the area between the plug terminals. Dust that accumulates between the plug terminals may cause a fire.
- When unplugging the power cord, be sure to hold onto the plug. Pulling on the power cord could damage the cord, resulting in a fire or electrical shock.

2.3 Precautions for Routine Use

	<ul style="list-style-type: none"> • Do not store toner units, PC drum units, and other supplies and consumables in a place subject to direct sunlight and high temperature and humidity, as poor image quality and malfunction could result. • Do not attempt to replace the toner unit and PC drum unit in a place exposed to direct sunlight. If the PC drum is exposed to intense light, poor image quality could result. • Do not unpack a toner unit or PC drum unit until the very time of use. Do not leave an unpacked unit standing. Install it immediately or poor image quality could result. • Do not keep toner units and PC drum units in an upright position or upside down, as poor image quality could result. • Do not throw or drop a toner unit or PC drum unit as poor image quality could result. • Do not use this product in an area where ammonia or other gases or chemicals are present. Failure to do so may shorten the service life of the product, cause damage or decrease performance. • Do not use this product in an environment with a temperature outside the range specified in the User manual, as a breakdown or malfunction could result. • Do not attempt to feed stapled paper, carbon paper or aluminum foil through this product, as a malfunction or fire could result.
	<p>Do not touch or scratch the surface of the toner unit developing roller and the PC drum, as poor image quality could result.</p>
	<p>Use the supplies and consumables recommended by the dealer. Use of any supply or consumable not recommended could result in poor image quality and breakdown.</p>

2.4 User Instructions

CE Marking (Declaration of Conformity)

This product complies with the following EU directives:
89/336/EEC, 73/23/EEC, 93/68/EEC, and 1999/5/EC directives.
This declaration is valid for the area of the European Union.

This device must be used with shielded interface cables. The use of non-shielded cable is likely to result in interference with radio communications and is prohibited under EU directives.

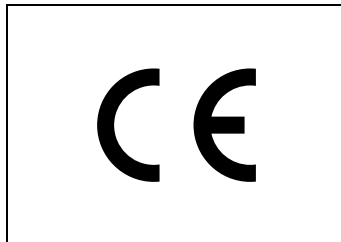

For New Zealand Users:

The grant of a Telepermit for any item of terminal equipment indicates only that Telecom has accepted that the item complies with minimum conditions for connection to its network. It indicates no endorsement of the product by Telecom, nor does it provide any sort of warranty. Above all, it provides no assurance that any item will work correctly in all respects with another item of Telepermitted equipment of a different make or model, nor does it imply that any product is compatible with all of Telecom's network service.

This equipment is not capable, under all operating conditions, of correct operation at the higher speeds for which it is designed. Telecom will accept no responsibility should difficulties arise in such circumstances.

This equipment shall not be set to make automatic calls to the Telecom "111" Emergency Service.

The call log incorporated in this equipment does not record all answered calls. The call log, therefore may not agree with the Telecom account which may include calls not shown on the log.

This equipment should not be used under any circumstances which may constitute a nuisance to other Telecom customers.

Not all telephones will respond to incoming ringing when connected to the extension socket.

2.5 Laser Safety

This is a digital machine which operates using a laser. There is no possibility of danger from the laser provided the machine is operated according to the instructions in this manual.

Since radiation emitted by the laser is completely confined within protective housing, the laser beam cannot escape from the machine during any phase of user operation.

This machine is certified as a Class 1 laser product: This means the machine does not produce hazardous laser radiation.

Internal Laser Radiation

Maximum Average Radiation Power: 28.9 μ W at the laser aperture of the print head unit.

Wavelength: 770-795 nm

This product employs a Class 3b laser diode that emits an invisible laser beam.

The laser diode and the scanning polygon mirror are incorporated in the print head unit.

The print head unit is **NOT A FIELD SERVICE ITEM**:

Therefore, the print head unit should not be opened under any circumstances.

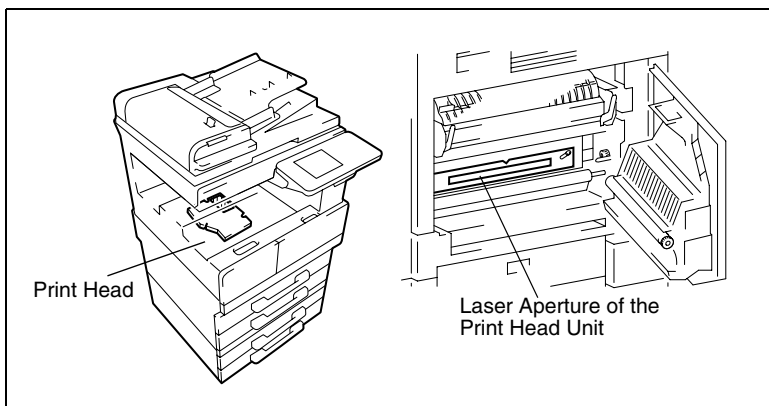

There is a laser aperture at the location shown above, which must, however, **NEVER** be viewed directly by the user.

CDRH Regulation

This machine is certified as a Class 1 Laser product under Radiation Performance Standard according to the Food, Drug and Cosmetic Act of 1990. Compliance is mandatory for Laser products marketed in the United States and is reported to the Center for Devices and Radiological Health (CDRH) of the U.S. Food and Drug Administration of the U.S. Department of Health and Human Services (DHHS). This means that the device does not produce hazardous laser radiation.

The label shown on page 2-9 indicates compliance with the CDRH regulations and must be attached to laser products marketed in the United States.

CAUTION

Use of controls, adjustments or performance of procedures other than those specified in this manual may result in hazardous radiation exposure.

This is a semiconductor laser. The maximum power of the laser diode is 5 mW and the wavelength is 770-795 nm.

For European Users

CAUTION

Use of controls, adjustments or performance of procedures other than those specified in this manual may result in hazardous radiation exposure.

This is a semiconductor laser. The maximum power of the laser diode is 5mW and the wavelength is 770-795 nm.

For Denmark Users

ADVARSEL

Usynlig laserstråling ved åbning, når sikkerhedsafbrydere er ude af funktion. Undgå udsættelse for stråling. Klasse 1 laser produkt der opfylder IEC60825 sikkerheds kravene.

Dansk: Dette er en halvlederlaser. Laserdiodens højeste styrke er 5mW og bølgelængden er 770-795 nm.

For Finland, Sweden Users

LOUKAN 1 LASERLAITE
KLASS 1 LASER APPARAT

VAROITUS!

Laitteen Käyttäminen muulla kuin tässä käyttöohjeessa mainitulla tavalla saattaa altistaa käyttäjän turvallisuusluokan 1 ylittävälle näkymättömälle lasersäteilylle.

Tämä on puolijohdelaser. Laserdiodin sunrin teho on 5mW ja aallonpituus on 770-795 nm.

WARNING!

Om apparaten används på annat sätt än i denna bruksanvisning specificerats, kan användaren utsättas för osynlig laserstrålning, som överskrider gränsen för laserklass 1.

Det här är en halvledarlasere. Den maximala effekten för laserdioden är 5mW och våglängden är 770-795 nm.

VARO!

Avattaessa ja suojalukitus ohitettaessa olet alttiina näkymättömälle lasersäteilylle. Älä katso säteeseen.

WARNING!

Osynlig laserstrålning när denna del är öppnad och spärren är urkopplad. Betrakta ej strålen.

For Norway Users

ADVERSEL

Dersom apparatet brukes på annen måte enn spesifisert i denne bruksanvisning, kan brukeren utsettes for usynlig laserstråling som overskrider grensen for laser klass 1.

Dette en halvleder laser. Maksimal effekt till laserdioder er 5mW og bølgelengde er 770-795 nm.

Laser Safety Label

A laser safety label is attached to the outside of the machine as shown below.

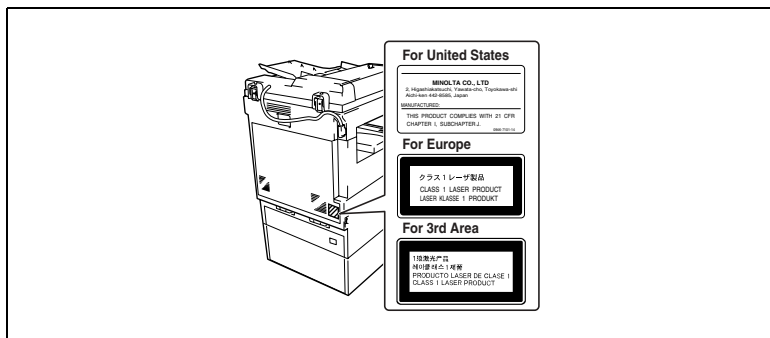

Ozone Release



CAUTION

Locate the Machine in a Well Ventilated Room

- A negligible amount of ozone is generated during normal operation of this machine. An unpleasant odor may, however, be created in poorly ventilated rooms during extensive machine operations. For a comfortable, healthy, and safe operating environment, it is recommended that the room well ventilated.

REMARQUE

= Placer l'appareil dans une pièce largement ventilée =

Une quantité d'ozone négligeable est dégagée pendant le fonctionnement de l'appareil quand celui-ci est utilisé normalement. Cependant, une odeur désagréable peut être ressentie dans les pièces dont l'aération est insuffisante et lorsque une utilisation prolongée de l'appareil est effectuée. Pour avoir la certitude de travailler dans un environnement réunissant des conditions de confort, santé et de sécurité, il est préférable de bien aérer la pièce ou se trouve l'appareil.

Acoustic Noise

For European Users

Machine Noise Regulation 3 GSGV, 18.01.1991: The sound pressure level at the operator position according to EN 27779 is equal to or less than 70dB(A).

2.6 Installation Precautions

Installation Site

To ensure utmost safety and prevent possible malfunctions, install the copier in a location that meets the following requirements.

- A location away from curtains, etc. that may catch fire and burn easily
- A location that is not exposed to water or other liquids
- A location free from direct sunlight
- A location out of the direct airflow of an air conditioner or heater, and not exposed to extremely high or low temperatures
- A well-ventilated location
- A location that is not exposed to high humidity
- A location that is not extremely dusty
- A location not subjected to undue vibrations
- A stable and level location
- A location where ammonia or other organic gases are not generated
- A location that does not put the operator in the direct airflow of exhaust from the copier
- A location that is not near any kind of heating devices

Power Source

The power source requirements are as follows.

- Voltage fluctuation: Maximum $\pm 10\%$
- Frequency fluctuation: Maximum ± 0.3 Hz
- Use a power source with as little voltage or frequency fluctuations as possible.

Space Requirements

To ensure easy copier operation, supply replacement, and maintenance, adhere to the recommended space requirements detailed below.

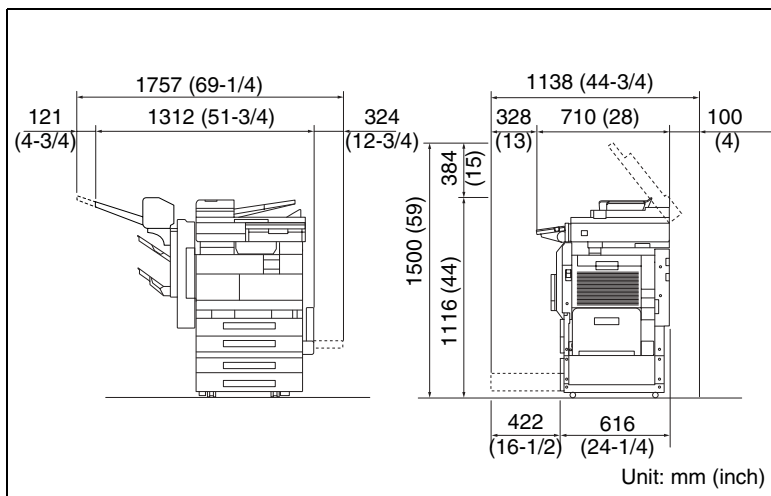

Note

Be sure to allow a clearance of 100 mm (4 in.) or more at the back of the copier for the ventilation duct.

2.7 Operation Precautions

Operating environment

The environmental requirements for correct operation of the copier are as follows.

- Temperature: 15°C (59°F) to 35°C (95°F) with fluctuations of no more than 10°C (18°F) within an hour
- Humidity: 15% to 85% with fluctuations of no more than 10% within an hour

Proper use

To ensure the optimum performance of the copier, follow the precautions listed below.

- Never place heavy objects on the original glass or subject it to shocks.
- Never open any copier doors or turn off the copier while it is making copies; otherwise, a paper jam will occur.
- Never bring any magnetized object or use flammable sprays or liquids near the copier.
- + Always make sure that the power plug is completely plugged into the electrical outlet.
- Always make sure that the copier's power plug is visible and not hidden by the copier.
- + Always unplug the copier from the electrical outlet if the unit is not to be used for a long period of time.
- + Always provide good ventilation when making a large number of continuous copies.



CAUTION

If the ventilation duct at the top of the copier becomes blocked, the inside of the copier will accumulate heat, resulting in a malfunction or fire.

- Do not place any objects over the ventilation duct.
-



CAUTION

The area around the fusing unit is extremely hot.

- Be careful not to touch any parts around the fusing unit, other than those indicated in this manual, in order to reduce the risk of burns. Be especially careful not to touch parts marked with warning labels, and their surrounding areas.
 - If you get burnt, immediately cool the skin under cold water, and then seek professional medical advice.
-

Transporting the copier

If you need to transport the copier over a long distance, consult your technical representative.

Care of copier supplies

Use the following precautions when handling the copier supplies (toner cartridge, paper, etc.).

- + Store the supplies in a location that meets the following requirements.
 - Free from direct sunlight
 - Away from any heating apparatus
 - Not subjected to high humidity
 - Not extremely dusty
- + Store in a sealed plastic bag in a cool, dark place paper that has been removed from its wrapper but not loaded into the copier.
- Only use toner that has been manufactured specifically for this copier. Never use other types of toner.
- Keep all supplies out of the reach of children.



CAUTION

Precautions for handling toner:

- Be careful not to spill toner inside the copier or get toner on your clothes or hands.
 - If your hands become soiled with toner, immediately wash them with soap and water.
 - If toner gets in your eyes, immediately flush them with water, and then seek professional medical advice.
-

Storage of copies

- + Copies that are to be kept for a long time should be kept where they are not exposed to light in order to prevent them from fading.
- Adhesive that contains solvent (e.g., spray glue) may dissolve the toner on copies.

2.8 Legal Restrictions on Copying

Certain types of documents must never be copied with the purpose or intent to pass copies of such documents off as the originals.

The following is not a complete list, but is meant to be used as a guide to responsible copying.

Financial Instruments

- Personal checks
- Travelers checks
- Money orders
- Certificates of deposit
- Bonds or other certificates of indebtedness
- Stock certificates

Legal Documents

- Food stamps
- Postage stamps (canceled or uncanceled)
- Checks or drafts drawn by government agencies
- Internal revenue stamps (canceled or uncanceled)
- Passports
- Immigration papers
- Motor vehicle licenses and titles
- House and property titles and deeds

General

- Identification cards, badges, or insignias
- Copyrighted works without permission of the copyright owner

In addition, it is prohibited under any circumstances to copy domestic or foreign currencies, or works of art without permission of the copyright owner.

When in doubt about the nature of a document, consult with legal counsel.

3 Available Features

3.1 Useful Operations

Installing the optional accessories expands the functionality of this copier.

Copying a Book or Magazine

The individual pages of a book or magazine can be duplicated onto double-sided copies (one page per side) in the original page order.

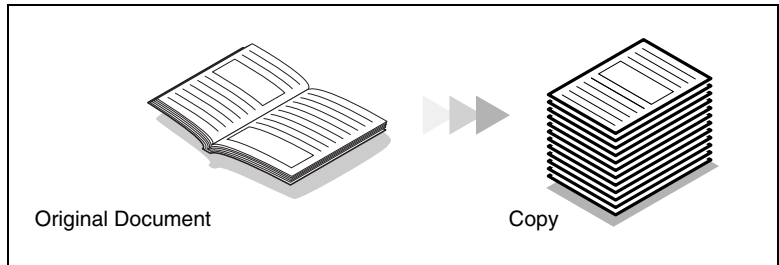

- 1 Position the document on the original glass with the center aligned with the book mark on the document scale.
 - Start copying from the lower numbered pages.

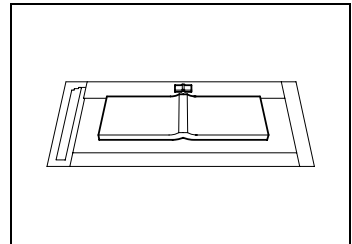

- 2 Touch [Orig. > Copy], and then touch [Book].

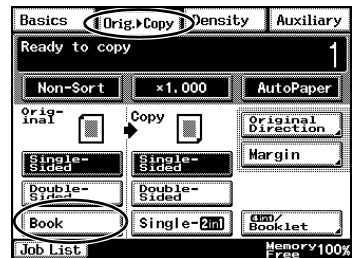

- 3 For book-binding, touch [Standard Book] or [RightBound], and then touch [Separation]. Next, touch [Enter].

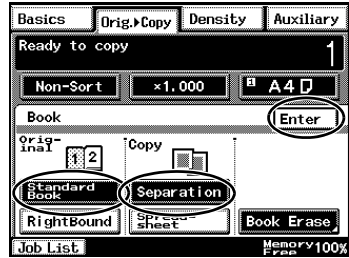

- 4 Touch [Double-Sided], and then touch [Page Order].

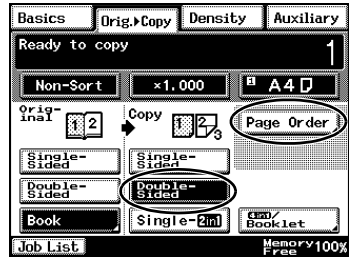

- 5 Touch [Book Order], and then touch [Enter].

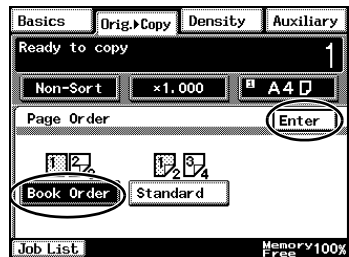

- 6 Press the [Start] key.

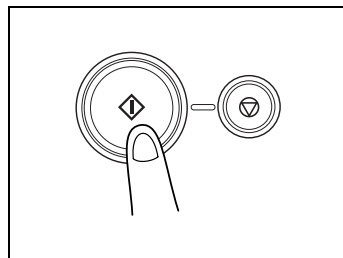

- 7 After the message shown at the right appears, turn the page of the book or magazine, re-position the document on the original glass, and then press the [Start] key.
- 8 Repeat step 7, and when the last page has been scanned, touch [Finish].
Next, press the [Start] key.

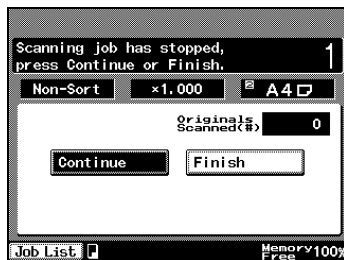

Copying to Form a Booklet

A document can be copied like a book so the pages can easily be put together to form a booklet.

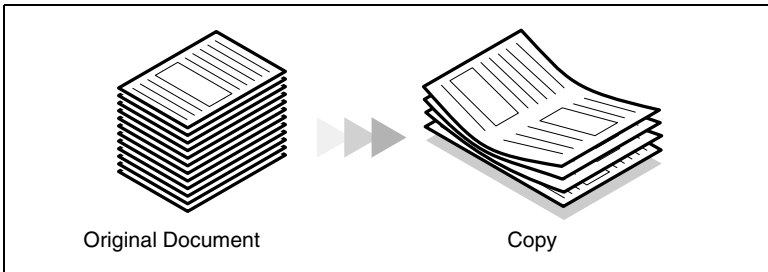

Note

In order to perform the following procedure, the optional duplexing document feeder must be installed.

- 1 Load the document into the duplexing document feeder.
 - The document can also be positioned on the original glass.

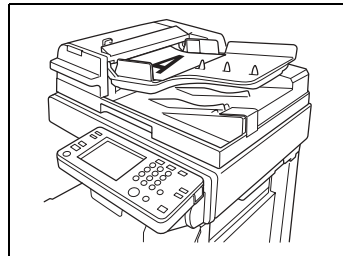

- 2 Touch [Orig. > Copy], and then touch [4in1/Booklet].

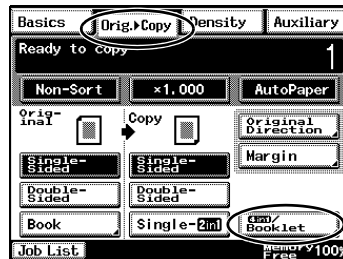

- 3 Touch [Booklet Creation], and then touch [Enter].

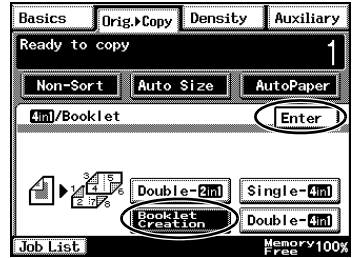

- 4 Press the [Start] key.

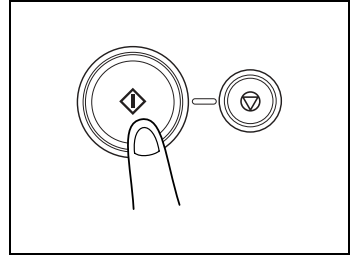

- 5 After all copies are printed, fold the pages in half to form a booklet.



Tip

If the optional saddle kit is installed, creasing or folding can be set. For details, refer to "Creasing and Folding" on page 11-9.

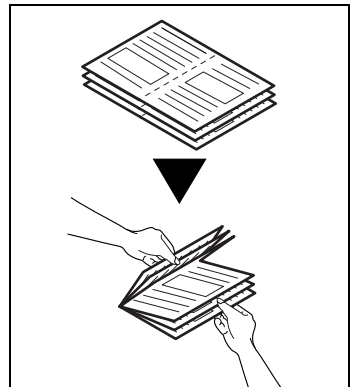

Automatically Stapling Pages While Copying

Each set of copies can easily be stapled together.

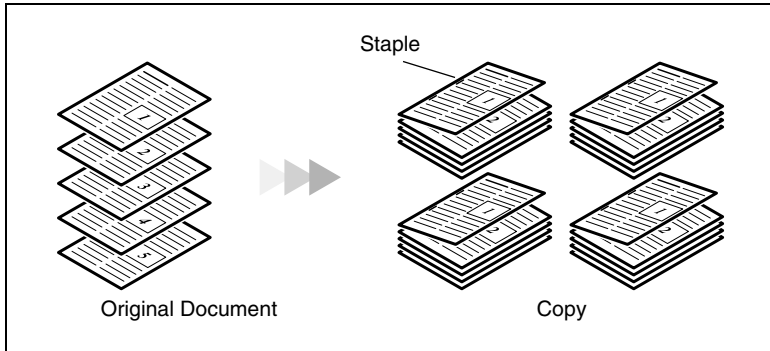

Note

In order to perform the following procedure, the optional duplexing document feeder, finisher must be installed.

- 1 Load the document into the duplexing document feeder.
 - The document can also be positioned on the original glass.

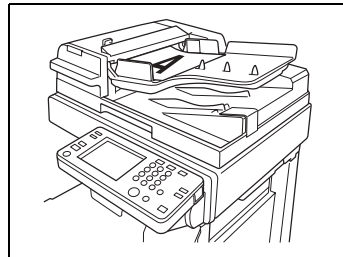

- 2 Touch [Finishing].

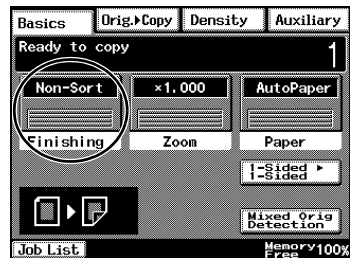

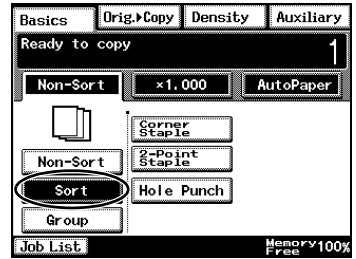
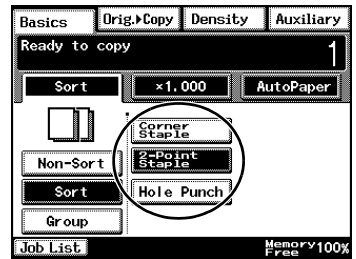
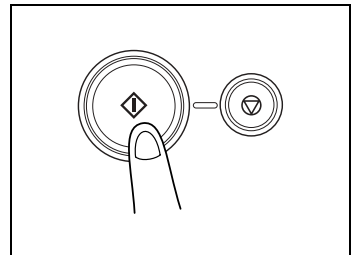
3 Touch [Sort].**4** Touch [2-Point Staple].**5** Press the [Start] key.

Printing Multiple Copies of Tickets

Tickets for a concert or some other event can easily be made.

As an example, the procedure for reducing a 210 mm × 74 mm document by 50% and copying it onto thick A4-size paper is described below.

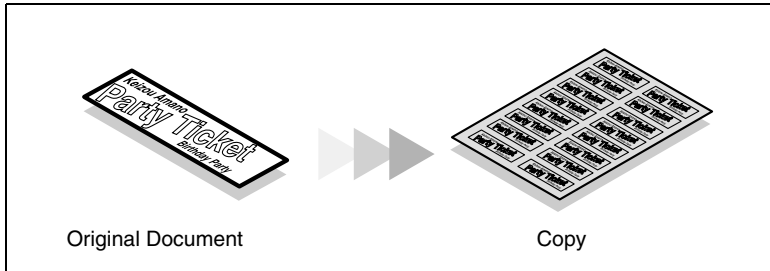

Important

Copying certain type of documents is prohibited by law. Making copies of these documents may be punishable as a crime. (For more details, refer to “Legal Restrictions on Copying” on page 2-15.)



Note

If the document is placed directly on the original glass and the size is detected automatically, the document will be scanned with a standard size.

If the document has a non-standard size, first measure the size of the document.

- 1 Position the document to be copied.

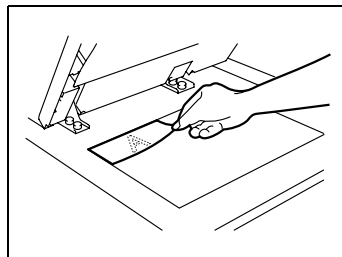

- 2 Open the multiple bypass tray and load it with paper.
 - A maximum of 50 sheets of thick paper can be loaded.

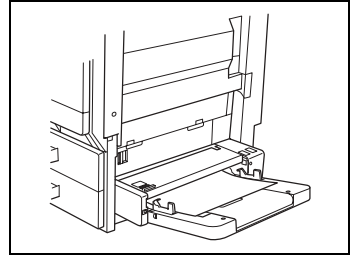

- 3 Touch [Paper].

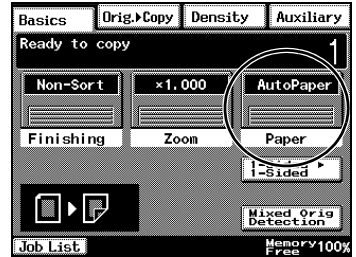

- 4 Touch the button for the multiple bypass tray, and then touch [Mode Change].

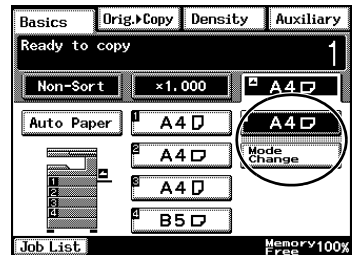

- 5 Touch [Card], and then touch [Enter].
 - If paper with a non-standard size is loaded, touch [Custom Size], and then specify the paper size. (For details, refer to page 9-14.)

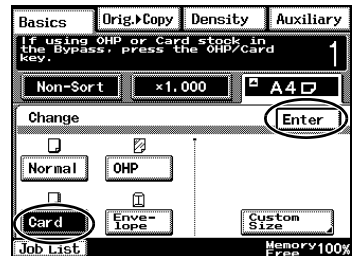

6 Touch [Zoom].

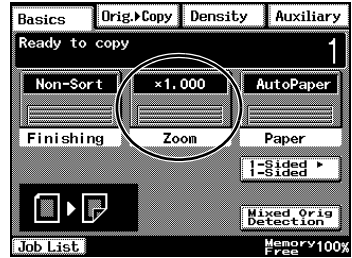
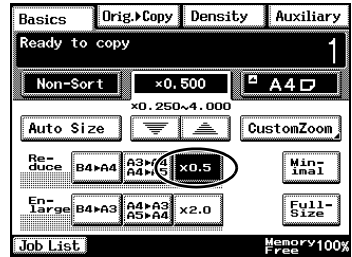
7 Touch [$\times 0.5$].

8 Touch [Auxiliary], and then touch [Image Repeat].

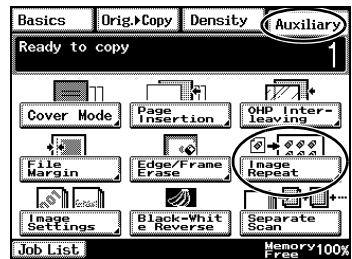

9 Touch [Size Input].



10 Touch [Custom Size].

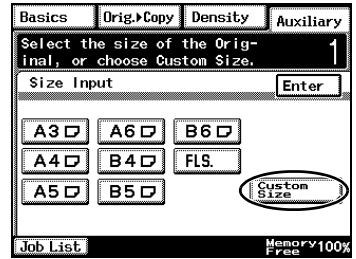

11 Touch [X]. Then, using the 10-Key Pad, type in the length of side X for the document.

- For this example, set the length of side X to "210".

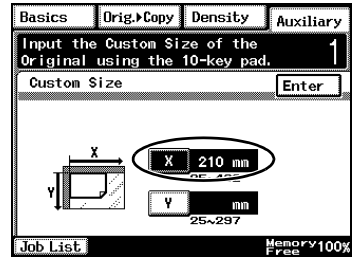

12 Touch [Y]. Then, using the 10-Key Pad, type in the length of side Y for the document.

- For this example, set the length of side Y to "74".

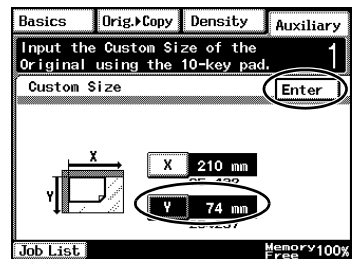

13 Press the [Start] key. Sixteen 105 mm x 37 mm tickets are copied onto one sheet of paper.

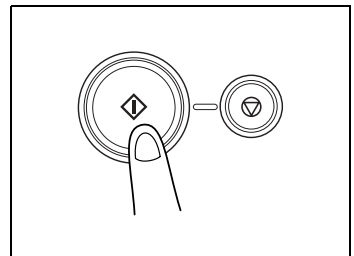

Copying While Erasing an Area Around the Document

When copying documents with unwanted markings, headers or punch holes, the pages can be printed with a frame or one side of the document erased.

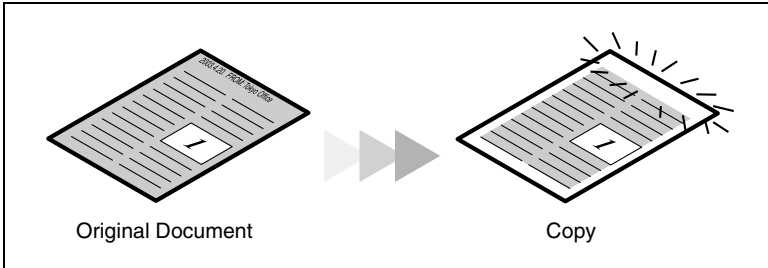
**Note**

The position and width of the area to be erased can be set so that it is appropriate for the document being copied.

The width of the erased area refers to how much of the document will be erased. If enlarged or reduced copies are made, the same width is erased and an enlarged or reduced copy is printed.

- 1 Position the document to be copied.

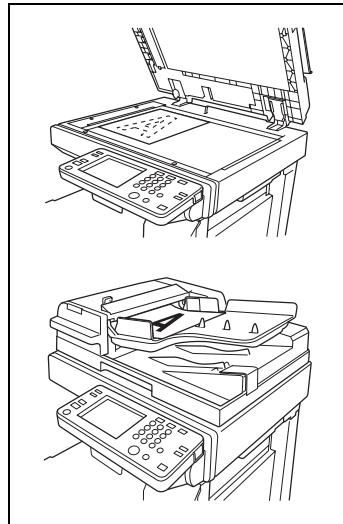

- 2 Touch [Auxiliary], and then touch [Edge/Frame Erase].

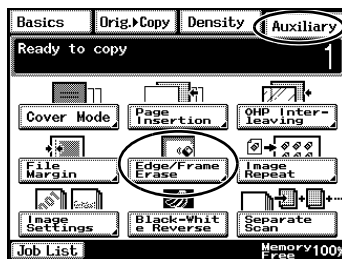

- 3 Select the desired position of the erased area.
(Example: Erasing a frame)



- 4 Touch the big arrow keys to specify the width of the erased area.



- 5 Touch [Enter].



6 Press the [Start] key.

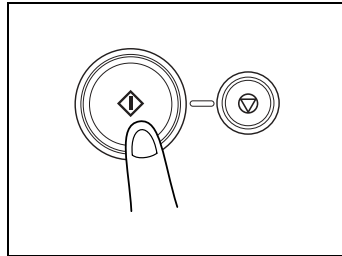

Reducing Paper Usage

Double-sided copying and 2in1 copying are useful in economizing on printed pages or reducing the size of a thick document.

As an example, the procedure for combining two single-sided document pages into a double-sided copy is described below.

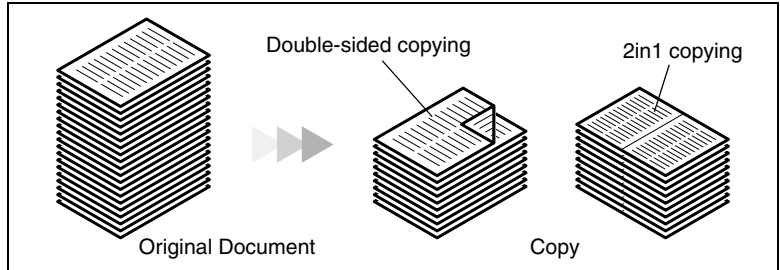

Note

In order to perform the following procedure, the optional duplexing document feeder must be installed.



Tip

Double-sided 2in1 copying and single-sided 4in1 copying reduce the paper usage by one fourth, and double-sided 4in1 copying reduces paper usage by one eighth.

- 1 Load the document into the duplexing document feeder.
 - The document can also be positioned on the original glass.

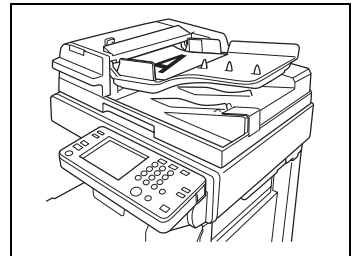

- 2 Touch [Orig. > Copy], and then touch [4in1/Booklet].

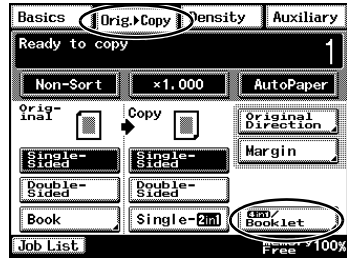

- 3 Touch [Double-2in1].

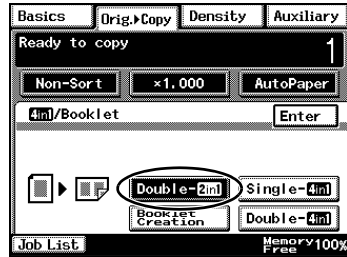

- 4 Press the [Start] key.

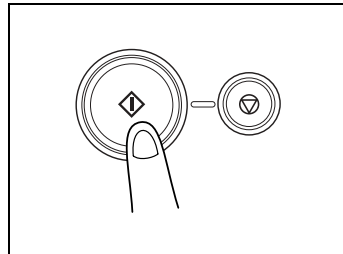

Reducing Electricity Usage

The copier can be set to a low power mode to conserve energy.

In order to perform these operations, the Energy Save mode and the Sleep mode can be used to automatically set the copier to an energy-saving mode when the copier is not used for a specified length of time.

- 1 Press the [Utility] key.

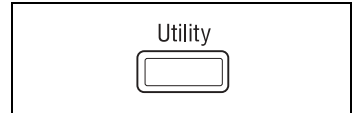

- 2 Touch [User's Choice].

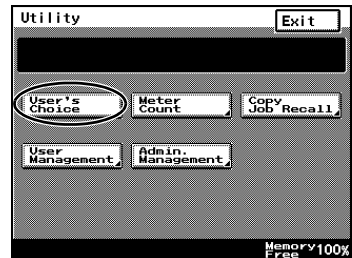

- 3 Touch [3/6].

- To specify settings for the Energy Save mode, continue with step 4.
- To specify settings for the Sleep mode, skip to step 7.

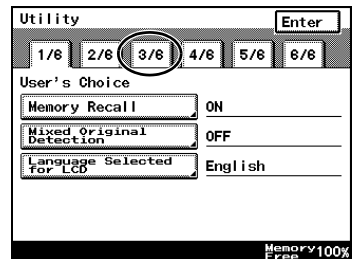

- 4 Touch [Energy Save Mode].

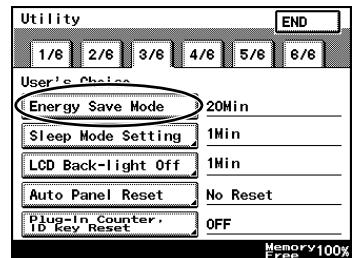

- 5 Press the [C] key to erase the current value, and then use the 10-Key Pad to specify the desired length of time until the copier enters Energy Save mode.

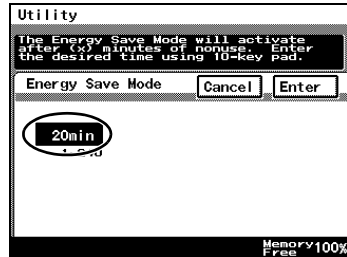

- 6 Touch [Enter].

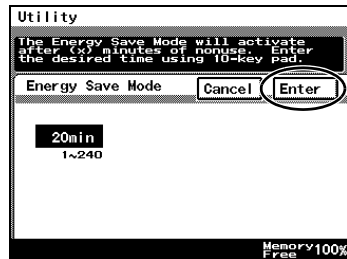

- 7 Touch [Sleep Mode Setting].

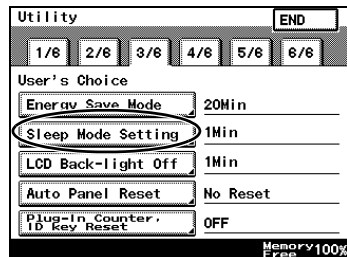

- 8 Use the 10-Key Pad to specify the desired length of time until the copier enters Sleep mode.

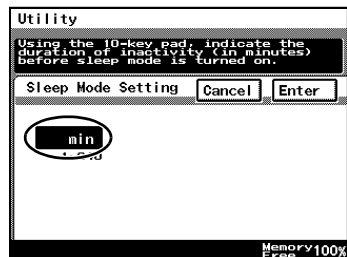

9 Touch [Enter].

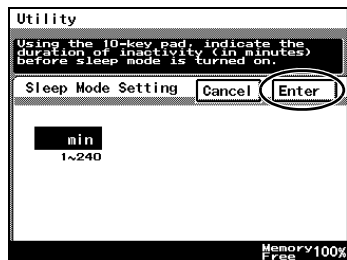

4 Before Making Copies

4.1 Names of Control Panel Parts and Their Functions

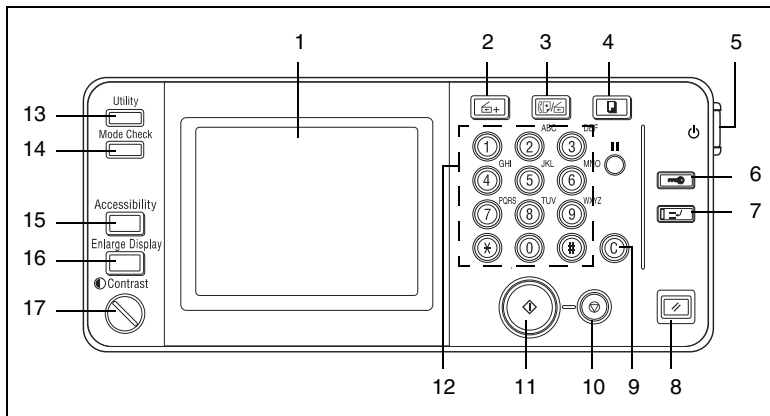

No.	Part Name	Function
1	Touch panel	Displays various screens and messages Touch items in the touch panel to select screens and specify settings.
2	Extra Scan key	Press to use the IP Scanner functions. (Internet Fax & Network Scan Kit and Network Interface Card must be installed.)
3	Scan key	Press to enter Scan mode. (Network Interface Card, and either Network Scan Kit or Internet Fax & Network Scan Kit must be installed.)
4	Copy key	Press to enter Copy mode.
5	Sub power switch	Use to turn the copier on and off.
6	Access key	Press when an access code must be entered. <ul style="list-style-type: none"> If the "Copy Track Mode" parameter is set to "OFF", nothing happens when this key is pressed.
7	Interrupt key	<ul style="list-style-type: none"> Press to enter Interrupt mode. To cancel Interrupt mode, press the [Interrupt] key again.
8	Panel Reset key	Press to reset all modes and functions to their default settings.
9	[C] (clear) key	<ul style="list-style-type: none"> Press to reset the number of copies to "1". Press to erase a setting (such as the zoom ratio or size) selected using the 10-Key Pad.

... continued on next page

No.	Part Name	Function
10	Stop key	<ul style="list-style-type: none">• Press to stop a copy operation.• Press to stop the scanning of a document.
11	Start key	Press to start a scanning or copy operation.
12	10-Key Pad	Use to enter a number, such as the number of copies.
13	[Utility] key	Used to display the Utility screen For more details, refer to chapter "7 Utility Mode Operations".
14	[Mode Check] key	<ul style="list-style-type: none">• Press to display a list of all specified settings. From this list, the screen to specify each setting can be displayed and the setting can be changed.• From this screen, the current settings can also be stored as a copy program.
15	[Accessibility] key	Press to activate or deactivate the user accessibility functions.
16	[Enlarge Display] key	Press to enlarge the screens that appear in the touch panel.
17	[Contrast] dial	Use to adjust the contrast of the touch panel.

4.2 Checking the Settings

The currently selected settings can be reviewed. In addition, the specified settings can be changed or stored for later use.

There are four screens that allow you to check the settings.

To check the settings

- 1 Press the [Mode Check] key in the control panel.

The first screen showing the current settings appears.

- 2 Touch [Next] to display the second, third or fourth screen of settings.
 - Touch [Back] to return to the previous screen of settings.
- 3 Touch [Exit] to return to the Basics screen.

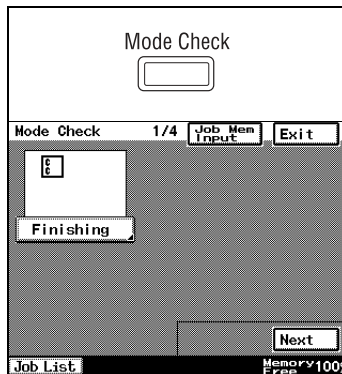

Tip

To change a setting, touch the button for the function that you wish to change. The screen to change the setting for the selected function appears.

In the screen that appeared, change the setting as desired.

To change the settings

- 1 Press the [Mode Check] key in the control panel.

The first screen showing the current settings appears.

- 2 Display the screen containing the setting that you wish to change.
 - To change the screens, touch [Next] and [Back].

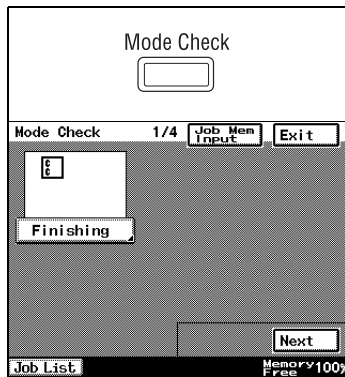

- 3 Touch the button for the setting that you wish to change.

The screen for specifying the setting appears.

- 4 Change the setting according to the corresponding procedure.



4.3 User Accessibility Operations

Various functions, such as the screen mode and the volume of alarms, can be specified, allowing the copier to be used more easily.

- 1 Press the [Accessibility] key in the control panel.
- 2 Touch either [Set] or [Reset].
 - The user accessibility functions can be enabled or disabled.
 - When the user accessibility functions are enabled, the [Accessibility] key lights up in green. When the user accessibility functions are disabled, the [Accessibility] key is not lit.

The screenshot shows the 'Accessibility' menu on a copier control panel. At the top, the word 'Accessibility' is displayed above a rectangular key icon. Below this is a header bar labeled 'Accessibility Settings' with an 'Enter' button on the right. The main menu consists of five rows, each with a dropdown menu on the left and a value on the right:

Screen Mode	Normal Screen
Key Speed Settings	0.3 / 0.1
Confirming Screen	None
Notification Screen	10 sec.
Sound Setting	Loud

At the bottom of the menu are two buttons: 'Set' and 'Reset'.

To change the screen display setting (“Screen Mode” function)

Select whether the screens appear in the touch panel in black on white or in white on black.

- 1 Press the [Accessibility] key in the control panel.
- 2 Touch [Screen Mode].
- 3 Touch [Inverted Screen] to display the screens in white on black. To return the screens to the normal display, touch [Normal Screen].

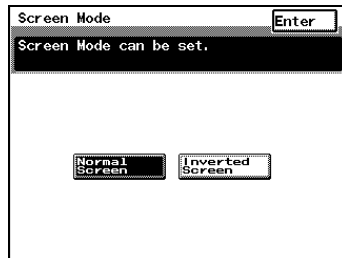

- 4 Touch [Enter].

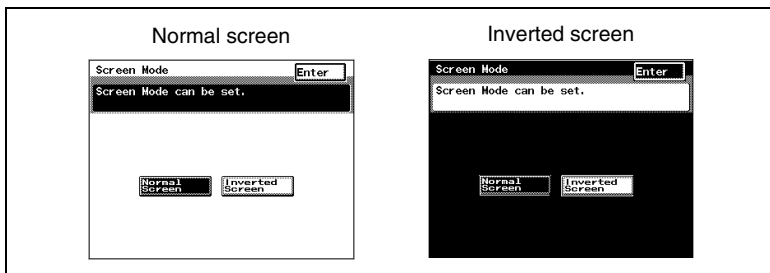

To change the key settings (“Key Speed Settings” function)

If the same key is held down, characters and number can be repeatedly entered.

- 1 Press the [Accessibility] key in the control panel.
- 2 Touch [Key Speed Settings].
- 3 Touch the arrow keys to adjust the time periods.

- Delay Time:
Time until the repeat feature for a key begins after the key is held down
- Interval Time:
Length of time (in seconds) that a key must be held down before repeatedly entering characters and numbers

Example: When the [1] key is held down:



Tip

Touch [CHECK] to check the specified settings.

- 4 Touch [Enter].

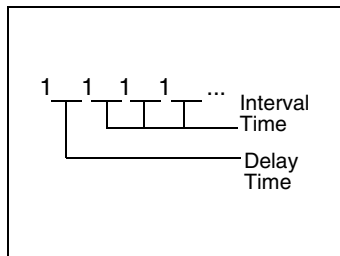
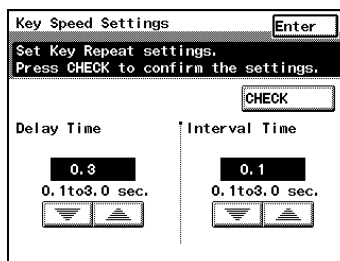

To change the auto panel reset time (“Confirming Screen” function)

If no operation is performed for a specified length of time, the touch panel display returns to the Basics screen. For details on specifying the default auto panel reset time, refer to chapter “7 Utility Mode Operations”.

On the “Confirming Screen”, you can set whether or not to extend the display time of the Auto Panel extension confirmation screen that is displayed immediately before it is automatically cleared.



Note

The Energy Save, Sleep, and LCD Back-light Off functions are still operable even when the Auto Panel Reset function is configured. When setting Auto Panel Reset, please set it to a shorter period than the Energy Save, Sleep, and LCD Back-light Off functions.

- 1 Press the [Accessibility] key in the control panel.
- 2 Touch [Confirming Screen].
- 3 Select the desired length of time for displaying the screen requesting confirmation to reset the copier.
 - Touch [30 sec.], [60 sec.], [90 sec.] or [120 sec.].
 - To immediately display the Basics screen without displaying a screen requesting confirmation to reset the copier, touch [None].
- 4 Touch [Enter].

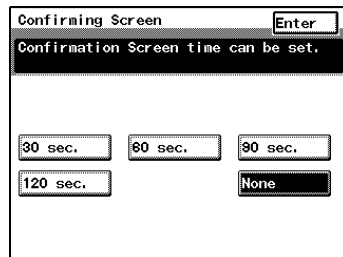

To change the display time for the “The job is accepted.” screen (“Notification Screen” function)

The length of time that the “The job is accepted.” screen, which requests confirmation of a reception number or job No. after copying is finished, can be specified.

- 1 Press the [Accessibility] key in the control panel.
- 2 Touch [Notification Screen].
- 3 Select the desired time setting.
 - Touch [3 sec.], [10 sec.] or [60 sec.].
 - To leave the “The job is accepted.” screen displayed until [Enter] is touched, touch [No Limit].
- 4 Touch [Enter].

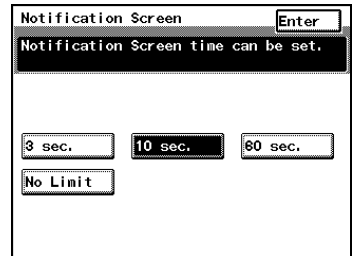

To change the volume of touch panel beeps and alarms (“Sound Setting” function)

The volumes of the beep that is sounded when a touch panel button is touched and of the alarm that is sounded when a malfunction occurs can be specified. During normal usage, a low volume is specified, however this function is convenient when a temporary increase in volume is desired. Basic volume setting can be set in User Management. For details, refer to “To adjust beep volumes (“Confirmation Beep” and “Alarm Volume” functions)” on page 7-37.

- 1 Press the [Accessibility] key in the control panel.
- 2 Touch [Sound Setting].
- 3 Select the desired volume setting.
- 4 Touch [Enter].

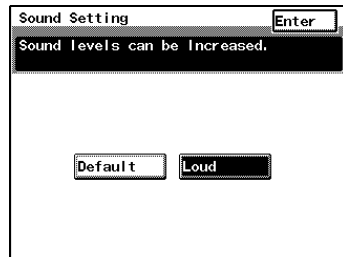

4.4 Enlarging the Touch Panel Screens

Press the [Enlarge Display] key to enlarge the screens that appear in the touch panel. Press the [Enlarge Display] key again to return the screens to the standard size. The usual touch panel operations can be performed even when the screens are enlarged.

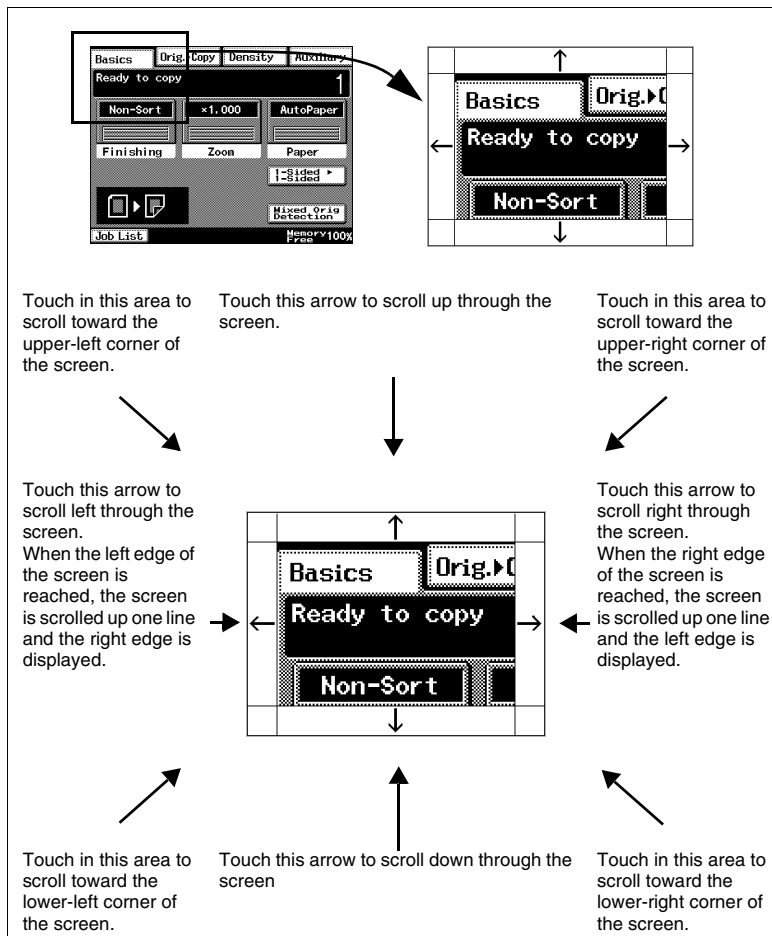

4.5 Turning the Copier On and Off

To turn on the copier

- 1 Set the power switch to “I”.

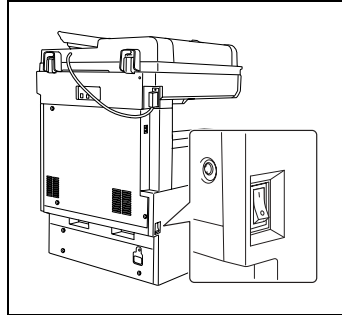

- 2 Make sure that the sub power switch has been pressed in.

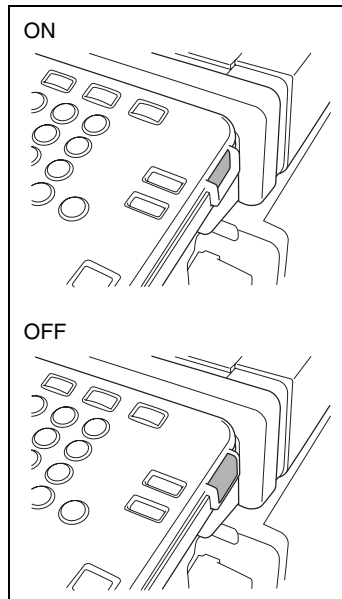

When the copier is turned on

- A few seconds after the copier is turned on, the message “Now warming-up. Ready to scan.” appears in the touch panel and the indicator on the [Start] lights up in green. When the indicator on the [Start] key lights up in green, a job can be queued.

When the power switch is on, and the sub power switch is in the off position, copies can not be taken.

To turn off the copier

- 1 Touch [Activity List] to check that no jobs are queued.
- 2 If any printed pages remain in the paper output tray, remove them.
- 3 Press the sub power switch to turn off the copier.
- 4 Set the power switch to “O”.

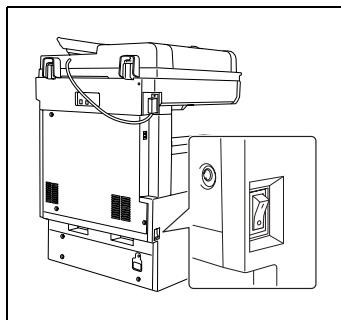

Tip

Normally, it is not necessary to set the power switch to “O”.



Note

When turning the copier off, then on again, wait five seconds after turning it off before turning it on again. If no time passes between turning the copier off until turning on again, the copier may not operate correctly.

Do not turn off the copier while it is making copies or printing, otherwise a paper misfeed may occur.

Do not turn off the copier while it is scanning or sending or receiving data, otherwise all scanned data or transmission data will be deleted.

Do not turn off the copier while a queued job or stored data is waiting to be printed, otherwise the jobs will be deleted.

When the copier is turned off

- Settings that have not been programmed will be cleared.
- Jobs that are queued to be printed are deleted.
- Data scanned using the “Scan to Memory” function is deleted.
- Scanned data that could be printed using the “Memory Recall” function is deleted.

Auto Panel Reset

When a specified period has passed, these will reset to the default settings.

Conditions for auto panel resetting

- 1 minute, or a specified period after the copier is last used (factory default settings are 1 minute).
- The magnetic card is removed from the data controller or the key counter is removed.



Note

The settings specifying whether or not and the time until the auto panel reset operation is performed can be changed. For details, refer to “Changing Default Settings” on page 7-6.

Energy Save Mode

In order to conserve energy, the copier will automatically enter a stand-by mode (Energy Save mode) if no operation is performed for a specified length of time. When the copier enters Energy Save mode, the indicator on the [Start] key remains lit in green, but the touch panel goes off.

At this time, the copier reduces the heat of the fusing section, and goes into Energy Save Mode.

Conditions for entering Energy Save mode

- 15 minute, or a specified period after the copier is last used (factory default settings are 15 minute).



Note

To recover from Energy Save mode, press any key in the control panel or touch the touch panel.

The copier will not enter Energy Save Mode while printing is paused.

The settings specifying whether or not and the time until the copier enters Energy Save mode can be changed. For details, refer to “Changing Default Settings” on page 7-6.

Sleep Mode

In order to conserve energy, the copier's heater goes off and the copier automatically enters Sleep mode if no operation is performed for a specified length of time.

Conditions for entering Sleep mode

- No copier operation is performed for 1 minute.



...

Note

To recover from Sleep mode, press any key in the control panel or touch the touch panel.

The settings specifying whether or not and the time until the copier enters Sleep mode can be changed. For details, refer to "Changing Default Settings" on page 7-6.

4.6 Adjusting the Angle of the Control Panel

The control panel can be adjusted to any of three angles.

Adjust the control panel to the angle that allows for easy operation.

- Pull the control panel release lever, and then adjust the angle of the control panel.

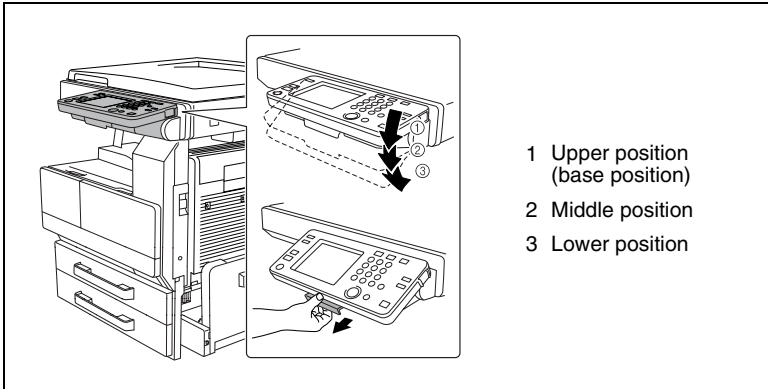

4.7 Using the Touch Panel

Description of the Touch Panel

When the copier is turned on, the screen shown below appears in the touch panel.

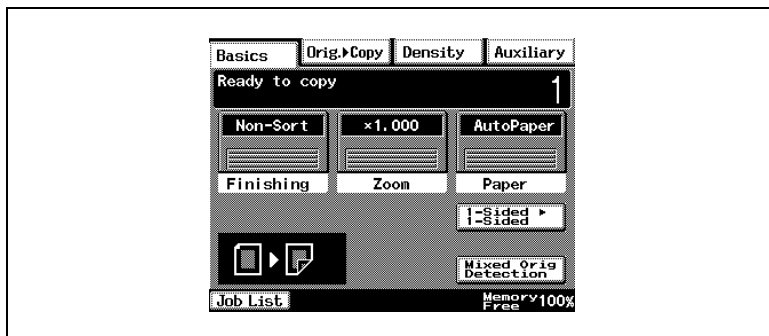

This screen is the Basics screen.

The screen shows, with messages and graphics, the currently selected settings, the settings that are available, and the copier status.

Default Settings

The settings selected when the copier is turned on are called the default settings. The default settings serve as a reference for all settings that are to be specified.

To change the default settings, refer to *“Changing Default Settings”* on page 7-6.

- Number of copies: 1
- Finishing: Non-Sort
- Zoom: 1.000 (Full Size)
- Paper: AutoPaper
- Density: Auto Exposure (Text/Photo mode)
- Orig. ► Copy: Single-Sided ► Single-Sided

Operating the Touch Panel

To activate a function or to select a setting, lightly touch the desired function or setting shown on the touch panel.



CAUTION

Be careful not to damage the touch panel.

- Never push down on the touch panel with force, and never use a hard or pointed object to make a selection in the touch panel.
-



Tip

The language of the displays in the touch panel can be changed using the “Language Selected for LCD” function on the User’s Choice screen. For details, refer to “Changing Default Settings” on page 7-6.

The default settings can be changed using the various functions on the User’s Choice screen. For details, “Changing Default Settings” on page 7-6.

Description of the Screens

Settings screen

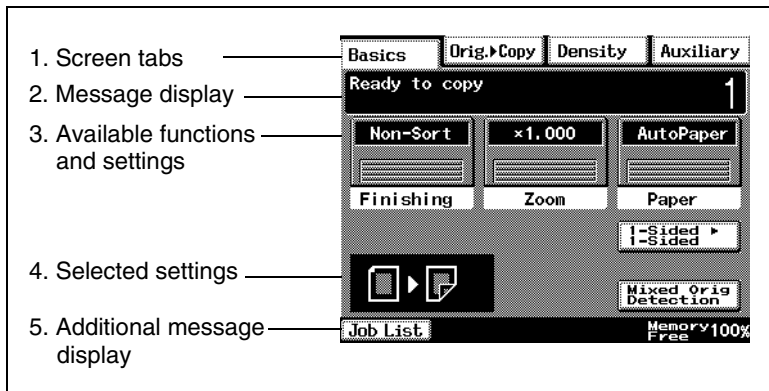

No.	Item Name	Description
1	Screen tabs	Each screen contains various functions that can be specified. Touch a tab to display the corresponding screen.
2	Message display	The current copier status, operating instructions, warnings/precautions, and other data including the number of copies selected are displayed here.
3	Available functions and settings	Selecting a screen displays various functions that can be specified. Touch the button for a function to display the corresponding settings.
4	Selected settings	The current settings are shown with graphics.
5	Additional message display	<ul style="list-style-type: none"> The status of the job is shown with graphics. The remaining amount of memory and graphics warning about empty toner or an empty paper drawer are displayed here.

Job List Screen

The operating status of the copier and the printing order of queued jobs can be viewed from this screen.

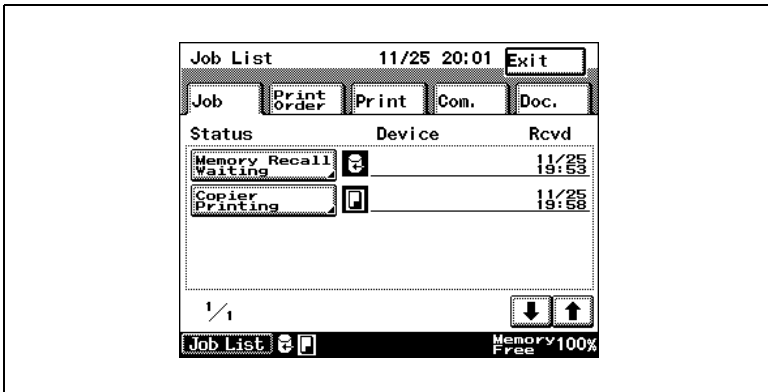

There are five tabs in the Job List screen.

- Job:
Displays a list of operations that are being performed
- Print Order:
Displays the order of documents that are being copied or printed or waiting to be copied or printed
- Print:
Displays the print status of documents being copied or printed
- Com.:
Not used
- Doc.:
Not used

To check the status of a job

- 1 Touch [Job List].



- 2 Select the job whose status you wish to check.



...

Tip

The statuses of up to four jobs are displayed. Touch the arrow keys to view the status of a job that is not displayed.

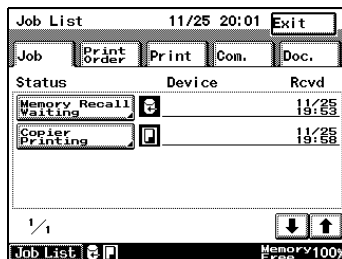

- 3 Check the details, and then touch [Enter].

- To delete the currently selected job, select that job and touch [Delete].

To check the printing order

1 Touch [Job List].

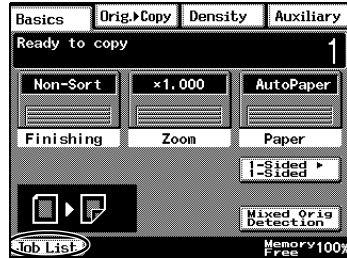

2 Touch [Print Order].

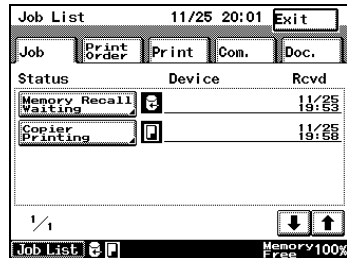

3 Check the printing order.

- Touch the arrow keys to view other parts of the list. Up to 8 items in the printing order can be displayed.

4 After checking the necessary information, touch [Enter].

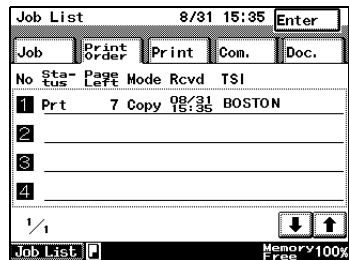

To check/delete listed items from the Print screen

1 Touch [Job List].

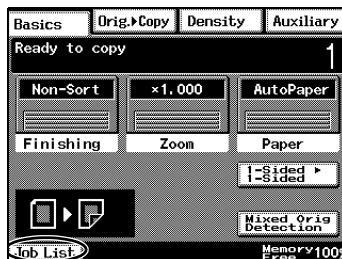

2 Touch [Print].

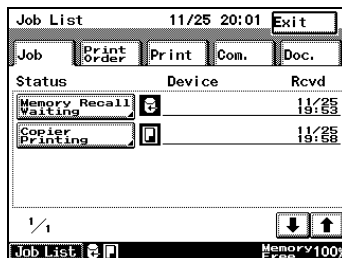

3 Select the job whose status you wish to check.

- Touch the arrow keys to view other parts of the list.

4 After checking the necessary information, touch [Enter].

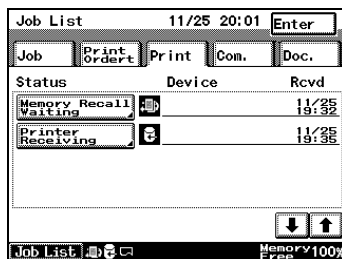

Note

To delete the job, select that job and touch [Delete].

Memory Recall

After printing of a copy job is finished, the image that was just copied can be printed again without the document being loaded.



Note

The memory recall feature is only available if the “Memory Recall” function (a User’s Choice function in the Utility mode) is set to “ON”. For details, refer to “User’s Choice screen” on page 7-1.



Tip

The memory recall feature cannot be used if any of the following have occurred:

A new document has been scanned. (The [Start] key has been pressed.)

The copier has been turned off.

The [Panel Reset] key was pressed while printing was stopped.

To use the memory recall feature

- 1 After copying is finished, touch [Job List].

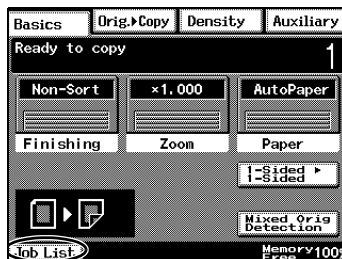

- 2 Touch [Memory Recall Waiting].
The information for the job still saved in the memory is displayed.

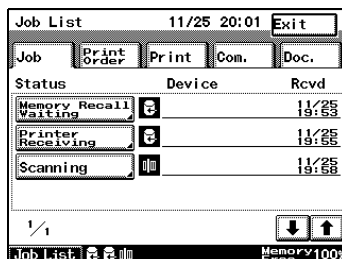

- 3 Touch [Memory Recall]
 - o To delete the job still saved in the memory, touch [Delete].

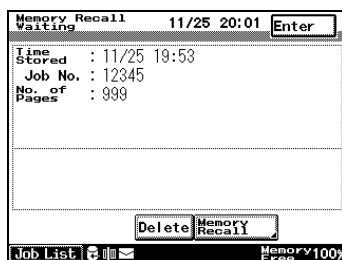

Tip

At this time, the Finishing setting and the number of copies can be changed.

- 4 Press the [Start] key.
The copies are printed.



Tip

After copying confidential documents, press the [Delete] key to erase the data from the memory.

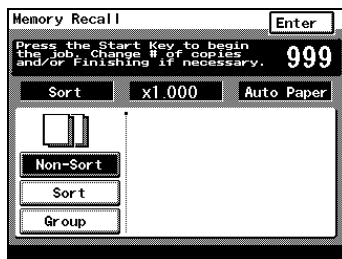

5 Basic Copy Operations

5.1 Making Basic Copies

The procedure for making basic copies is described below.

- 1 Position the document(s) to be copied.
 - For details, refer to “10 Original Documents”.

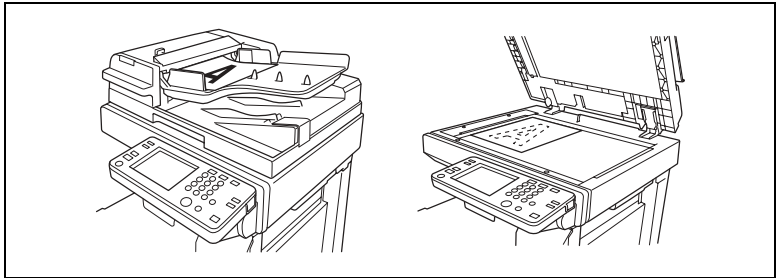

- 2 Check that the [Copy] key indicator is lit in green and that the copier is in Copy mode.

- The Basics screen appears in the touch panel.

- 3 Specify any necessary copy settings.

- To change the paper size (paper drawer), touch [Paper]. For details, refer to “Selecting the Paper Setting” (page 9-19).
- To change the zoom ratio, touch [Zoom]. For details, refer to “Specifying a Zoom Setting” (page 11-13).
- To sort, staple or punch holes in the copies, touch [Finishing]. For details, refer to “Specifying Finishing Settings” (page 11-1).
- To copy a book or copy while using less paper, touch [Orig. > Copy]. For details, refer to “Selecting the Orig. > Copy Settings” (page 11-18).
- To change the density of the copy, touch [Density]. For details, refer to “Selecting a Copy Density” (page 11-31).

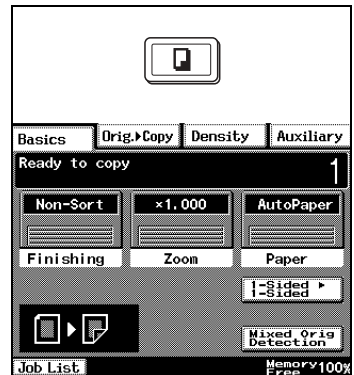

- To erase a margin in the copy, to insert interleave while copying onto overhead projector transparencies, or to perform any other special operation, touch [Auxiliary].
For details, refer to chapter “6 Auxiliary Functions”.

4 Use the 10-Key Pad to enter the desired number of copies.

- to 999 copies can be printed.
- To change the setting, press the [C] key, and then enter the correct setting.

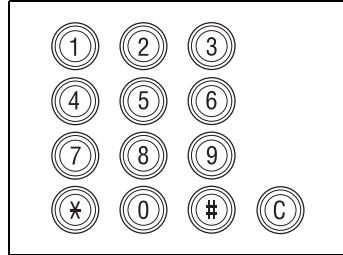

Tip...

*A limit on the number of copies can be specified from the Administrator Management screen of the Utility mode.
For details, refer to chapter “8 Administrator Management Operations”.*

5 Press the [Start] key.

The copies are printed.

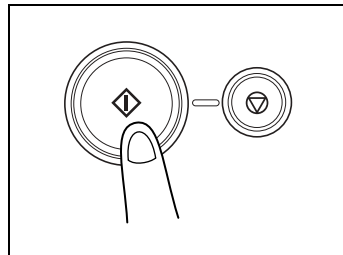

5.2 Stopping Copying

Follow the procedure described below to cancel a copy job.

To stop/restart/delete a copy job

- 1 Press the [Stop] key while the job is being printed.

Copying stops.

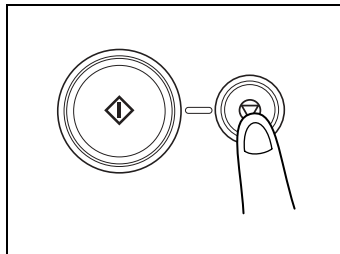

- 2 The message “Copy cycle temporarily suspended.” appears.

- 3 To restart a job that has been stopped, press the [Start] key.

Copying continues.

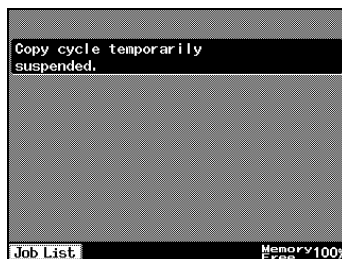

- 4 To delete the stopped copy job, select the button for the job that you wish to delete.

The job is deleted.

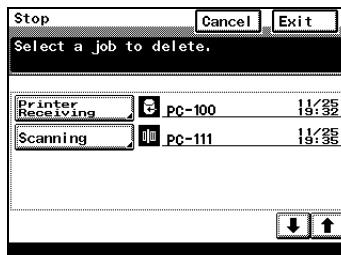

5.3 Interrupting a Copy Job

The current copy job can be paused so that a copy of a different document can be made.

This is convenient if you wish to quickly make copies of a short document while a large job is being printed.



Note

If certain functions are specified, it may not be possible to interrupt the copy job. In addition, some functions are not available while a copy job is interrupted.

The copier will not enter Interrupt mode (pause copying by pressing the [Interrupt] key) while a document is being scanned.

For details, refer to the "Function Combination Table" on page 14-11.

To interrupt copying

- 1 Press the [Interrupt] key while a job is being printed.

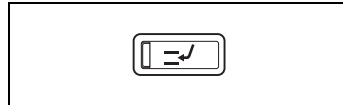

- The indicator on the [Interrupt] key lights up.
 - The message "Now in the interrupt mode." appears.
 - The copy settings return to their defaults.
(The copy settings of the job before the interruption and the remaining number of copies are recorded.)
 - If no operation is performed for one minute after the [Interrupt] key is pressed, the Interrupt mode is automatically cancelled.
- 2 Position the document(s) to be copied.
 - 3 Select the desired copy settings.
 - 4 Press the [Start] key.
 - Scanning of the document begins.
 - 5 When the interrupt mode copy has completed, press the [Interrupt] key.

The indicator on the [Interrupt] key goes off and the Interrupt mode is cancelled.

The copy settings for the job before copying was interrupted appear, and copying of the job that was interrupted automatically continues.

5.4 Making Copies Using Accounts

Using the “Copy Track Mode” Parameter

The number of copies allowed for each registered account can be restricted.

The accounts can be managed by touching [Account management] on the Admin. 1 screen (displayed by touching [Admin. Management] on the Utility screen). The Administrator Management settings should be specified by the administrator.



Note

The Administrator Management parameters cannot be set by anyone without knowledge of the administrator access code.

For details on the administrator access code, contact your service representative.

To make copies when accounts are specified

When managing using [100 Account 1] and [100 Account 2].

- 1 If [100 Account 1] has been specified, the screen shown at right is displayed.
 - If [100 Account 2] has been specified, pressing the [Access] key will display the screen shown at right.
- 2 Enter the 6-digit access code using the 10-Key Pad.



- 3 Press the [Access] key.
The Basics screen appears.
- 4 Make copies using the desired copy settings.
- 5 When you are finished making copies, press the [Access] key.
The access code input screen appears again.



When managing using [1000 Account].

- 1 Where [1000 Account] is selected, the Account Number input screen is displayed.

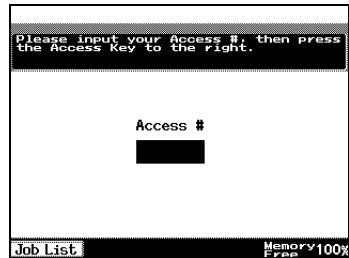

- 2 Input the account number used (1 to 999) in the Account Number Input Screen, and press the [Access] key.
The Basics screen is displayed.
- 3 Copying will take place using the desired copy mode.
- 4 When copying has finished, press the [Access] key again.

The Settings Screen is displayed on the Account Number Input Screen.



6 Auxiliary Functions

This chapter contains descriptions on making copies using the Auxiliary functions.

6.1 “Cover Mode” Function

Adding Cover Pages

When two or more sheets are being copied, cover pages using paper other than the document paper can be added.



Note

Load the paper for the cover pages into a paper drawer different than the drawer that contains the paper for the document.

Load paper for the cover pages with the same orientation and size as the paper for the document.

The optional duplexing document feeder must be installed.

Cover Mode settings

- Front Cover: Blank
Back Cover: None
- Front Cover: Blank
Back Cover: Blank

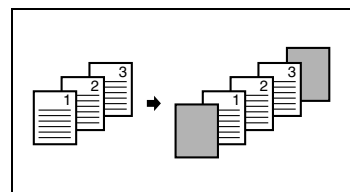
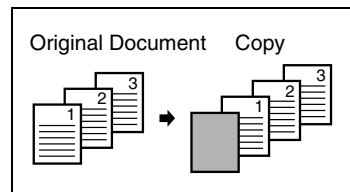

- Front Cover: Blank
Back Cover: With Image

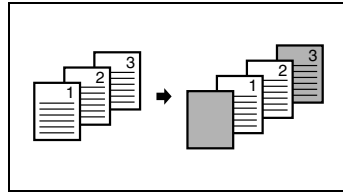

- Front Cover: With Image
Back Cover: None

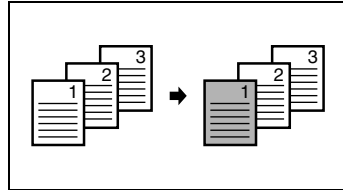

- Front Cover: With Image
Back Cover: Blank

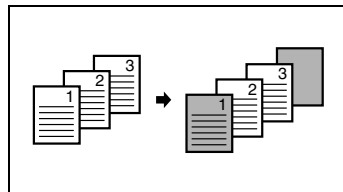

- Front Cover: With Image
Back Cover: With Image

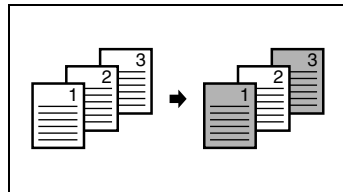

To make settings for the “Cover Mode” function

- 1 Load the document into the duplexing document feeder.
- 2 Touch [Auxiliary], and then touch [Cover Mode].

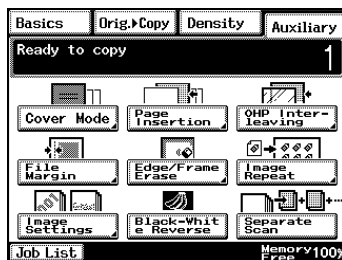

- 3 Select the desired Front Cover and Back Cover settings, and then touch the button below “Cover Paper”.

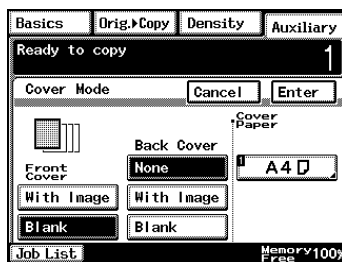

- 4 Select the paper drawer that contains the paper for the cover pages, and then touch [Enter].
- 5 Touch [Enter].
 - If [Cancel] is touched, the setting is cancelled.
- 6 Press the [Start] key.
The copies are printed.

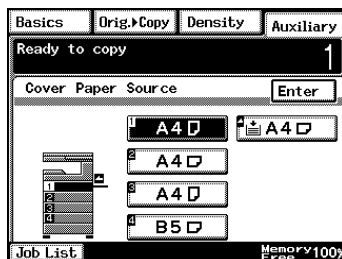

6.2 “Page Insertion” Function

Inserting Pages (Interleaves) Between Copies

When two or more sheets are being copied, paper (interleaves) other than the document paper can be inserted.



Tip

At the locations where you wish to insert interleaves, insert paper with a different orientation or size as the paper for the original, and then load the document into the duplexing document feeder.

Load the paper for the interleaves into a paper drawer different than the drawer that contains the paper for the document.

Load the paper for the interleaves with the same orientation and size as the paper for the document.

This function cannot be used together with the “Cover Mode” function.

This function cannot be used together with booklet-printing and mixed original sizes.



Note

The optional duplexing document feeder must be installed.

Paper Insertion settings

- Blank

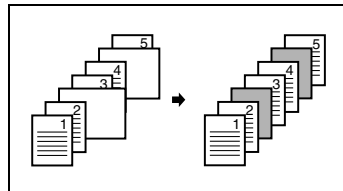

- With Image

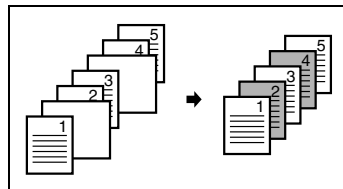

To make settings for the “Page Insertion” function

1 Load the document into the duplexing document feeder.

2 Touch [Auxiliary], and then touch [Page Insertion].

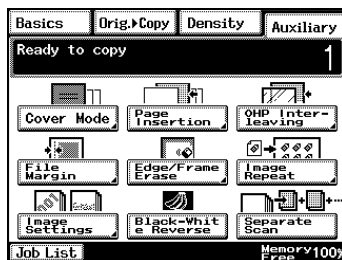

3 Select either the [With Image] or the [Blank] Page Insertion setting, and then touch the button below “Insert Paper”.

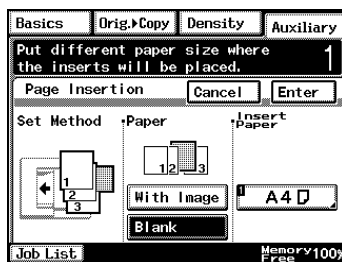

4 Select the paper drawer that contains the paper for the interleaves, and then touch [Enter].

5 Touch [Enter].

- If [Cancel] is touched, the setting is cancelled.

6 Press the [Start] key.

The copies are printed.

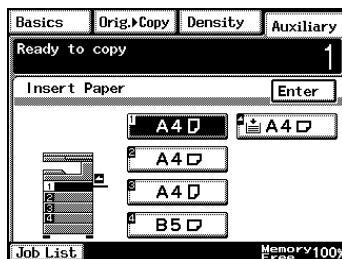

6.3 “OHP Interleaving” Function

Inserting Pages Between Copies of Transparencies

When copying overhead projector transparencies, paper (interleaves) can be inserted between copies of the transparencies.



Tip

Load the paper for the interleaves into a paper drawer, and load the overhead projector transparencies into the multiple bypass tray.

OHP Interleaving settings

- Blank

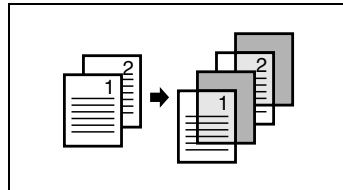

- With Image

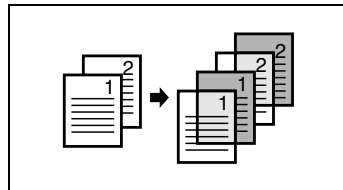

To make settings for the “OHP Interleaving” function

- 1 Load the document into the duplexing document feeder or position it on the original glass.
- 2 Touch [Auxiliary], and then touch [OHP Interleaving].

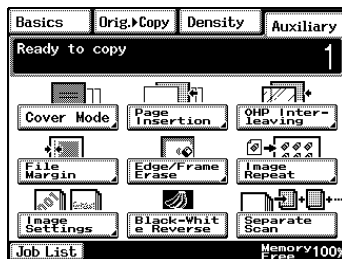

- 3 Select either the [With Image] or the [Blank] OHP Interleaving setting, and then touch the button below “Insert Paper”.



- 4 Select the paper drawer that contains the paper for the transparency interleaves, and then touch [Enter].
- 5 Touch [Enter].
 - If [Cancel] is touched, the setting is cancelled.
- 6 Press the [Start] key.
The copies are printed.

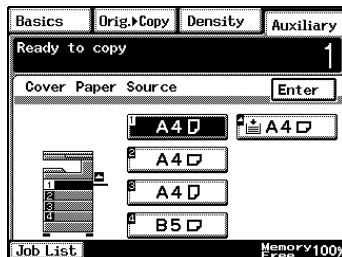

6.4 “File Margin” Function

Making Copies With Binding Margins

Copies can be made with binding margins and the image shifted to the side so that the text is not hidden when the copies are bound.

File Margin settings

- The position of the binding margin can be at the left side or at the top of the paper.
- The width of the binding margin can be specified.

The image of the document is shifted to the right to make a margin along the left edge of the copy.

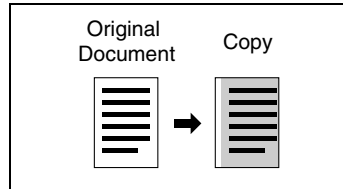

The image of the document is shifted to the bottom to make a margin along the top edge of the copy.

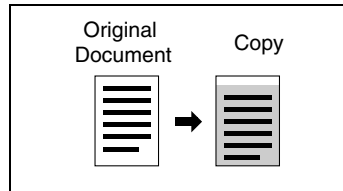

To make settings for the “File Margin” function

- 1 Load the document into the duplexing document feeder or position it on the original glass.
- 2 Touch [Auxiliary], and then touch [File Margin].

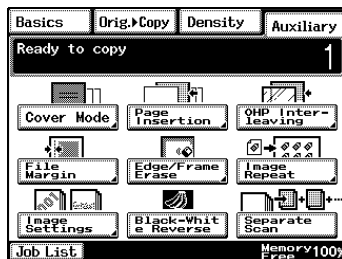

- 3 Select the desired File Margin setting.

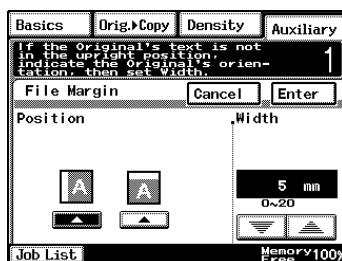

Tip

If the setting for the left binding position is selected for double-sided copying, the front and back sides of the page will be printed with the same orientation.

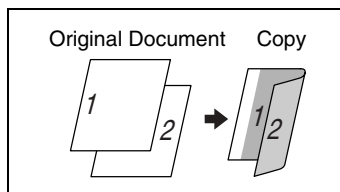

If the setting for the top binding position is selected for double-sided copying, the back side of the page is printed upside down.

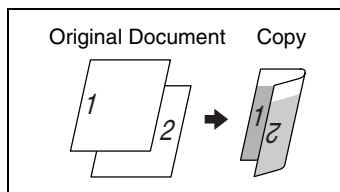

- 4 Touch the big arrow keys to specify the width of the binding margin, and then touch [Enter].
 - If [Cancel] is touched, the setting is cancelled.
- 5 Press the [Start] key.
The copies are printed.

6.5 “Edge/Frame Erase” Function

Erasing Sections of Copies

When copying documents with punch holes, the pages can be printed with part of the document erased.

Edge/Frame Erase settings

- The left side of the document is erased.
- The top edge of the document is erased.
- A frame around the document is erased.

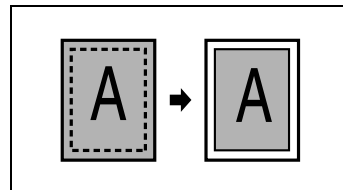
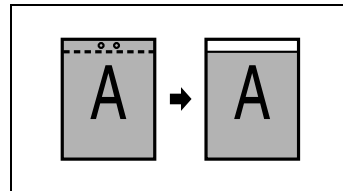
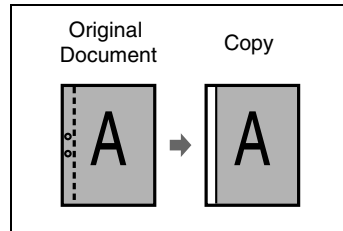

To make settings for the “Edge/Frame Erase” function

- 1 Load the document into the duplexing document feeder or position it on the original glass.
- 2 Touch [Auxiliary], and then touch [Edge/Frame Erase].

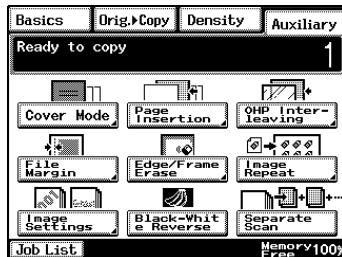

- 3 Select the desired Edge/Frame Erase setting.
- 4 Touch the big arrow keys to specify the width of the erased area, and then touch [Enter].
 - If [Cancel] is touched, the setting is cancelled.
- 5 Press the [Start] key.
The copies are printed.



6.6 “Image Repeat” Function

Printing Multiple Copies of the Same Document Page on One Sheet

The “Image Repeat” function can be used as shown below.

- To copy an A4-size page at full size onto an A3-size sheet of paper

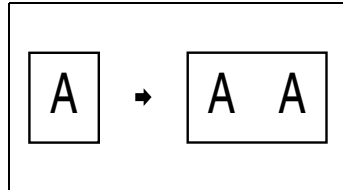

- To reduce an A4-size page and print multiple copies onto an A4-size sheet of paper

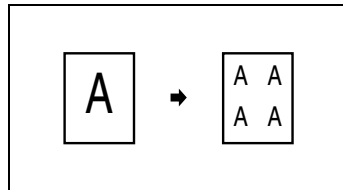

To make settings for the “Image Repeat” function

- 1 Load the document into the duplexing document feeder or position it on the original glass.
- 2 Touch [Auxiliary], and then touch [Image Repeat].

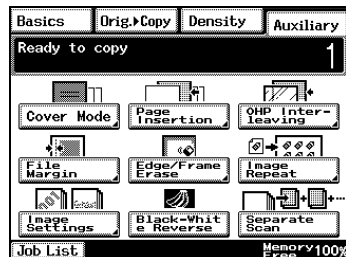

- 3 Touch [Size Input].
 - To automatically detect the document size, touch [Auto Detect].



4 Select the size of the document.

- If the document has a non-standard size, touch [Custom Size], and then specify the size of the document.

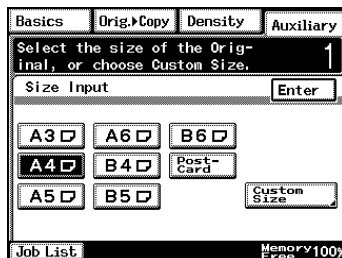

5 Touch [X].

Use the 10-Key Pad to type in the length of side X for the paper that is loaded.

6 Touch [Y].

Use the 10-Key Pad to type in the length of side Y for the paper that is loaded.

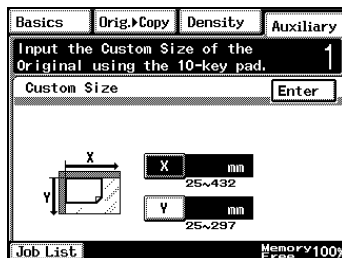

7 Touch [Enter].

- If [Cancel] is touched, the setting is cancelled.

8 Press the [Start] key.

The copies are printed.

6.7 “Distribution #” Function

Printing Distribution Numbers on Sets of Copies

Each set of copies can be printed with a distribution number added to the background.



Tip

If the “Distribution #” function is used, the “Sort” Finishing setting is selected.

After “999” is printed, the number returns to “000”.

To make settings for the “Distribution #” function

- 1 Load the document into the duplexing document feeder or position it on the original glass.
- 2 Touch [Auxiliary], and then touch [Image Settings].

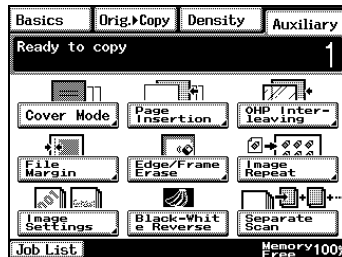

- 3 Touch [Distribution #].

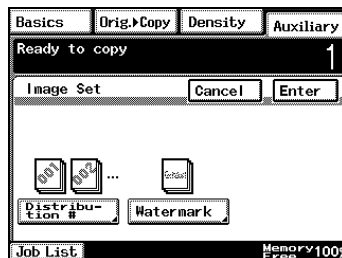

4 Specify the desired Distribution # settings.

- Using the 10-Key Pad, type in the first distribution number to be printed.
- If [First page only] is selected, the distribution number is only printed on the first page of each copy set.
- If [All Pages] is selected, the distribution number is printed on all pages of each copy set.
- Touch [Darker], [Normal] or [Lighter] to specify the print density for the distribution number.

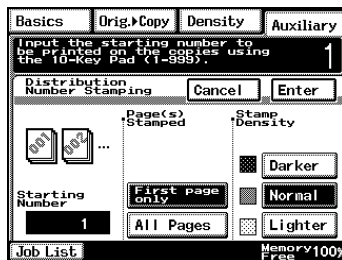

5 Touch [Enter].

- If [Cancel] is touched, the setting is cancelled.

6 Press the [Start] key.

The copies are printed.

6.8 “Watermark” Function

Copies can be printed with a watermark added to the background.

To make settings for the “Watermark” function

- 1 Load the document into the duplexing document feeder or position it on the original glass.

- 2 Touch [Auxiliary], and then touch [Image Settings].

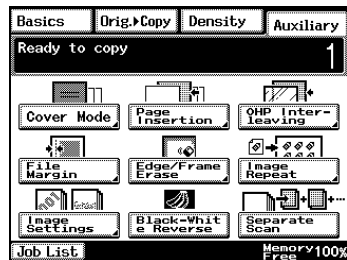

- 3 Touch [Watermark].

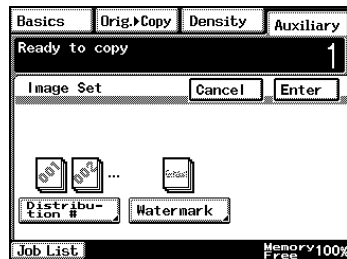

- 4 Select the watermark to be printed and the pages that the watermark will be added to.

- If [First page only] is selected, the watermark is only printed on the first page of each copy set.
- If [All Pages] is selected, the watermark is printed on all pages.



- 5 Touch [Enter].

- If [Cancel] is touched, the setting is cancelled.

- 6 Press the [Start] key.

The copies are printed.

6.9 “Image Stamping” Function

With this function, copies can be printed with a watermark of a scanned image added to the background. Refer to “*Registering an Image Stamp*” on page 7-31 for registration methods.



Note

The optional hard disk must be installed.

To make copies using the “Image Stamping” function

- 1 Load the document into the duplexing document feeder or position it on the glass.
- 2 Touch [Auxiliary], and then touch [Image Settings].

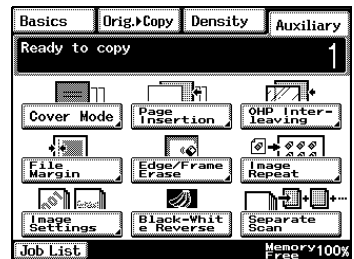

- 3 Touch [Image Stamping].

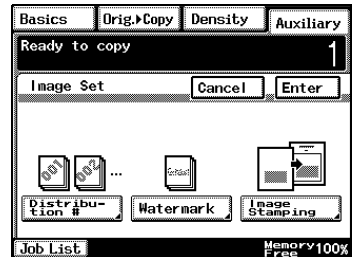

- 4 Touch [Set], select the registration number to be used, and then touch [Enter].
 - You can check this by selecting [Check], pressing the [Start] key, and copying the registered image.

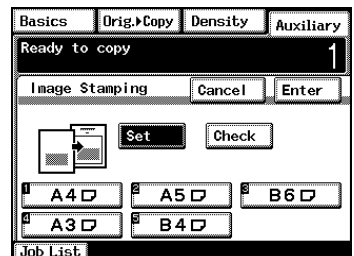

- 5 Select the desired printing position.
 - If [First page only] is selected, the image is only printed on the first page.
 - If [All Pages] is selected, the image is printed on all pages.
- 6 Touch [Enter].
 - If [Cancel] is touched, the setting is cancelled.
- 7 Press the [Start] key.

The copies are printed.

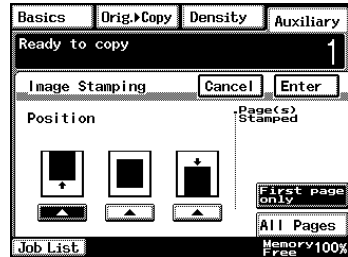

6.10 “Black-White Reverse” Function

Reversing White- and Black-Colored Areas of Copies

Copies can be printed with the white- and black-colored areas of the original image reversed.

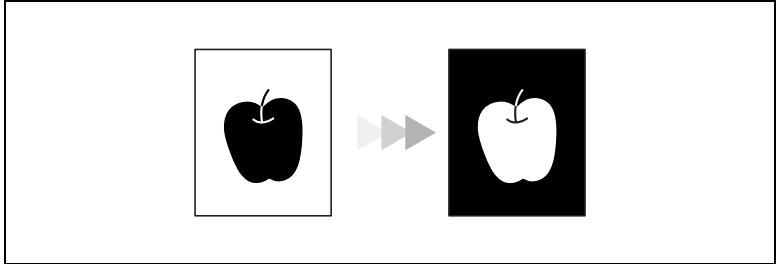

Tip

The white and black colors of the distribution number and watermark will not be reversed.

The white and black colors of the original cannot be reversed after the document has been scanned.

To set the “Black-White Reverse” function

- 1 Load the document into the duplexing document feeder or position it on the original glass.
- 2 Touch [Auxiliary], and then touch [Black-White Reverse].
- 3 Press the [Start] key.
The copies are printed.

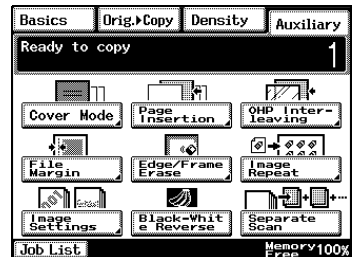

6.11 “Separate Scan” Function

Scanning a Document in Separate Batches

When copying a document with a large number of pages, the document can be divided and scanned in separate batches, and then it can be printed as a single document.



Tip

If the memory becomes full while scanning, scanning is stopped. If this occurs, press the [Start] key to print the pages that were scanned before scanning was stopped.

To make copies using the “Separate Scan” function

- 1 Load the document into the duplexing document feeder or position it on the original glass.
- 2 Touch [Auxiliary], and then touch [Separate Scan].
- 3 Press the [Start] key.
The document is scanned.
- 4 After the first document batch is scanned, load the second document batch into the duplexing document feeder or position it on the original glass, and then press the [Start] key.
- 5 After all document batches have been scanned, touch [Finish].
- 6 Press the [Start] key.
The copies are printed.

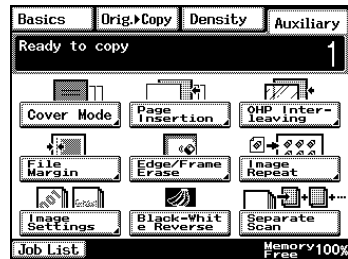

7 Utility Mode Operations

7.1 Utility Mode Screens

This chapter contains descriptions on the various copy programs and settings available in the Utility mode.

Utility screen

This screen appears when the [Utility] key is pressed.

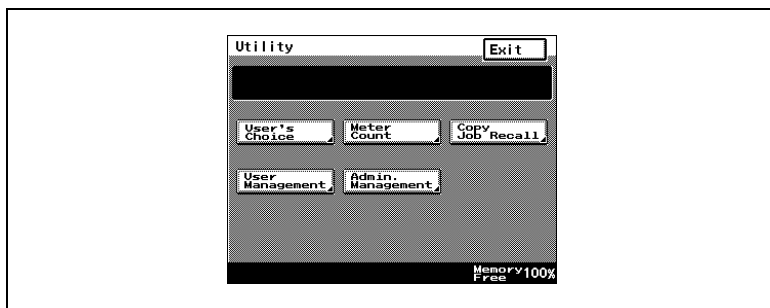

The following screens appear when the corresponding button is touched.

User's Choice screen

This screen provides functions for specifying various default settings for the copier.

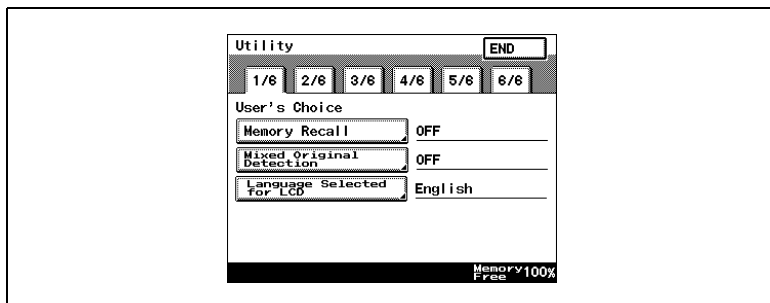

Meter Count screen

This screen shows the total number of copies printed since the copier was installed.

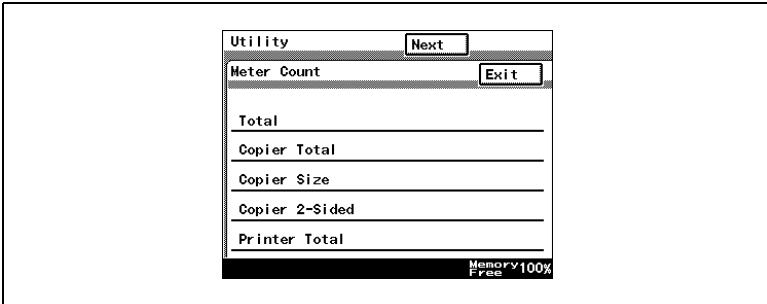

Copy Job Program Recall screen

From this screen, a programmed copy job can be recalled.

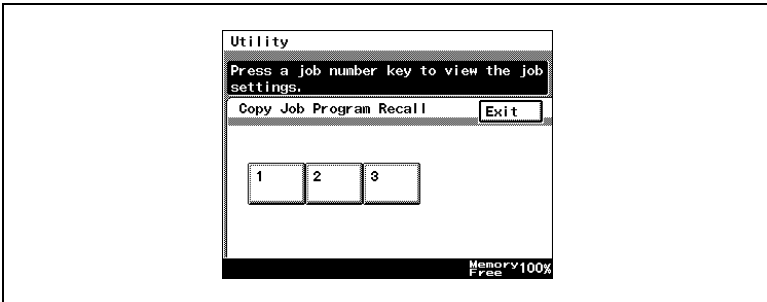

User Management screen

This screen provides various functions for safely and correctly using the copier.

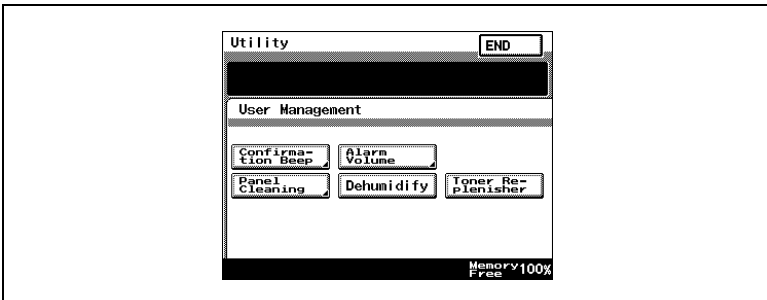

Administrator Management screens

There are two screens: Administrator Management 1 and Administrator Management 2. The administrator access code must be entered before these screens can be displayed.

For details on the functions available from the Administrator Management screens, refer to “8 Administrator Management Operations”.

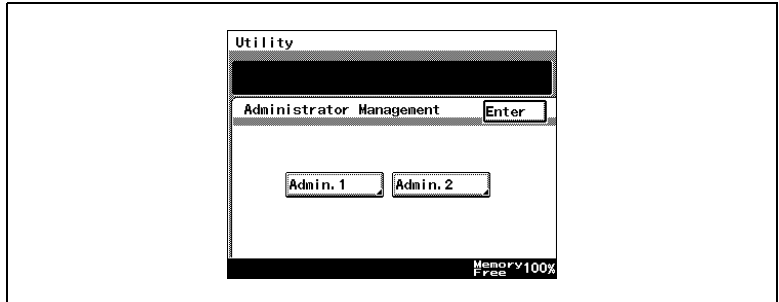



7.2 User's Choice Functions

The functions available on the User's Choice screen are described below.

Changing the settings for the following functions changes the default setting (the setting selected after the copier is turned on or the [Panel Reset] key is pressed).

The underlined settings indicate the default settings.

Tab	Function	Settings
1/6	Memory Recall	ON, OFF
	Mixed Original Detection	ON, OFF
	Language Selected for LCD	Japanese, English , German, French, Dutch, Italian, Spanish, Portuguese, Norwegian, Danish, Swedish, Finnish,
2/6	Original ► Copy Default	1-Sided ► 2-Sided, 2-Sided ► 2-Sided, 1-Sided ► 1-Sided
	Auto Paper/Auto Size	Auto Paper , Auto Size, Manual
	Drawer Priority	1st paper drawer
	Special Paper	Normal , Not for 2 Sided, Recycled, Special
	Multiple-in-1 and Booklet Copy Zoom	ON , OFF
3/6	Energy Save Mode	1 to 240 minutes, 15 minutes
	Sleep Mode Setting	1 to 240 minutes, 15 minutes
	LCD Back-light Off	1 to 240 minutes, 1 minutes
	Auto Panel Reset	No Reset, 30 seconds, 1 min , 2 min, 3 min, 5 min
	Plug-In Counter, ID key Reset	ON , OFF
4/6	4in1 Copy Order	
	Density Priority	Auto , Manual Text, Photo, Text/Photo
	Default Copy Output Levels	Auto (Lighter, Normal , Darker) Manual  One of nine settings between "Lighter" and "Darker" can be selected.
	Printing Density	-2, -1, 0, 1, 2
	Output Priority	Non-Sort , Sort, Group, Corner Staple*, 2-Point Staple*, Hole Punch* *Options

Tab	Function	Settings
5/6	Intelligent Sorting	ON , OFF
	Output Tray	Specify the bin of the finisher (option).
	"Small" Originals	ON, OFF
	Scanner Dry	Specify the time for dehumidifying the scanner.
	Crease/Center Staple	Crease (-10 to +10, 0) Center staple (-10 to +10, 0)
6/6	Density (ADF only)	Mode 1, Mode 2

7.3 Changing Default Settings

The procedures for changing each of the User's Choice settings are described below.

To set the "Memory Recall" function

This function is used to specify whether or not the last image copied can be recalled and printed again.

- 1 Press the [Utility] key.
- 2 Touch [User's Choice].
- 3 Touch [1/6], and then touch [Memory Recall].

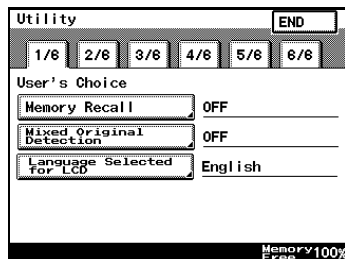

- 4 Touch [ON] or [OFF], and then touch [Enter].
 - If [ON] is selected, the previously copied image data can be printed again, even after copying has finished or while the copier is stand-by.

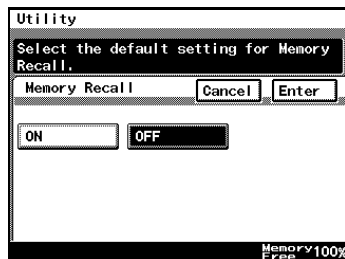

- 5 Touch [END] to return to the Utility screen, and then touch [Exit] to return to the Basics screen.

To set the “Mixed Original Detection” function

This function is used to specify whether or not the “Mixed Original Detection” function is set as the default.

- 1 Press the [Utility] key.
- 2 Touch [User’s Choice].
- 3 Touch [1/6], and then touch [Mixed Original Detection].

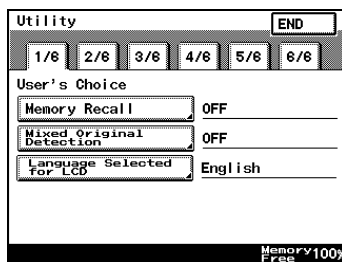

- 4 Touch [ON] or [OFF], and then touch [Enter].
- 5 Touch [END] to return to the Utility screen, and then touch [Exit] to return to the Basics screen.

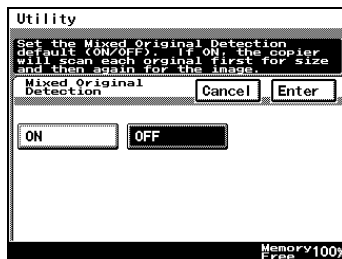

To set the “Language Selected for LCD” function

This function is used to specify the language for the screens that appear in the touch panel.

- 1 Press the [Utility] key.
- 2 Touch [User's Choice].
- 3 Touch [1/6], and then touch [Language Selected for LCD].

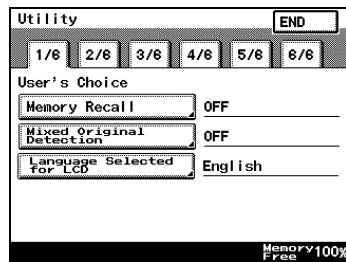

- 4 Select the desired language, and then touch [Enter].
- 5 Touch [END] to return to the Utility screen, and then touch [Exit] to return to the Basics screen.



To set the “Original > Copy Default” function

The function specifies the default Orig. ► Copy setting.

- 1 Press the [Utility] key.
- 2 Touch [User’s Choice].
- 3 Touch [2/6], and then touch [Original > Copy Default].

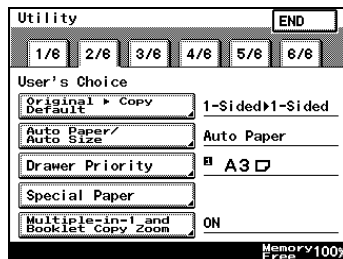

- 4 Select the desired setting, and then touch [Enter].
- 5 Touch [END] to return to the Utility screen, and then touch [Exit] to return to the Basics screen.

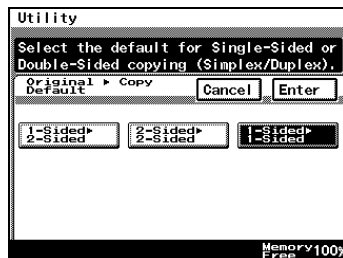

To set the “Auto Paper/Auto Size” function

This function is used to specify whether the “Auto Paper” Paper setting, the “Auto Size” Zoom setting or the “Manual” setting is set as the default.

- 1 Press the [Utility] key.
- 2 Touch [User’s Choice].
- 3 Touch [2/6], and then touch [Auto Paper/Auto Size].

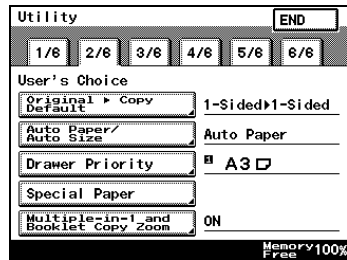

- 4 Select the desired setting, and then touch [Enter].
- 5 Touch [END] to return to the Utility screen, and then touch [Exit] to return to the Basics screen.

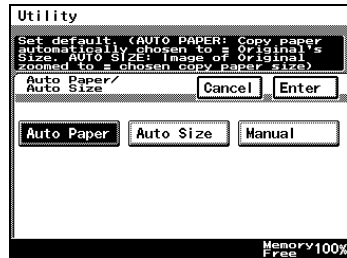

To set the “Drawer Priority” function

You can specify the priority of the paper that is selected (paper drawer).

For example, if you specify a paper drawer for paper that you use frequently, (recycled paper, single-sided only paper, etc.), that drawer will have priority when supplying paper. However, this function will not operate when there are settings such as auto paper selection, or where paper is limited.

- 1 Press the [Utility] key.
- 2 Touch [User's Choice].
- 3 Touch [2/6], and then touch [Drawer Priority].

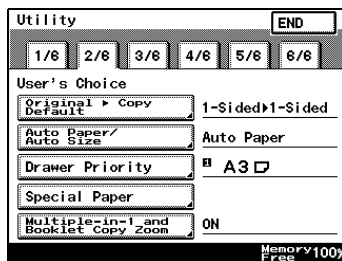

- 4 Select the desired paper drawer, and then touch [Enter].
- 5 Touch [END] to return to the Utility screen, and then touch [Exit] to return to the Basics screen.

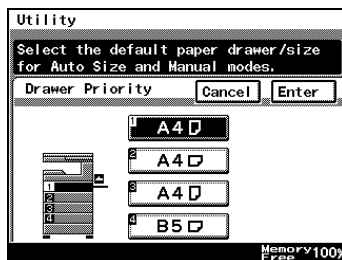

To set the “Special Paper” function

This function is used to specify the default paper type for a paper drawer when special paper, for example, recycled paper, is loaded into a particular paper drawer.





Tip

If a particular paper drawer is set to be loaded with special paper, the paper in that paper drawer will not be selected during automatic paper selection.

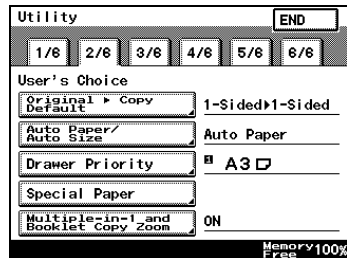
- 1 Press the [Utility] key.
- 2 Touch [User's Choice].
- 3 Touch [2/6], and then touch [Special Paper].



- 4 Select the paper drawer loaded with special paper, select the paper type, and then touch [Enter].

- : Recycled Paper
Selecting this mode means that when auto paper selection is selected, that paper tray will not be selected. For example, when plain paper and recycled paper are both able to be used, but where plain paper is mainly used, selecting this mode will mean that plain paper will have priority when being used.
- : Not for 2 Sided paper
Selecting this mode will mean that double sided copies on paper in that paper tray will not be possible.

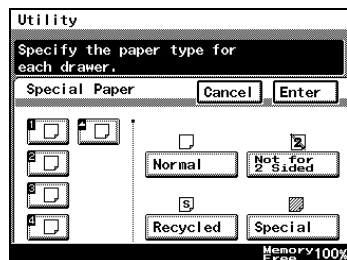

- : Special paper
Selecting this mode will mean that when using auto paper selection, this will not be included in auto tray change. When using colored paper for cover pages or interleaves, selecting this setting reduces operating errors.

- 5 Touch [END] to return to the Utility screen, and then touch [Exit] to return to the Basics screen.

To set the “Multiple-in-1 and Booklet Copy Zoom” function

This function is used to specify whether or not the preset Zoom setting appropriate for the document and paper size is set when a 2in1 or a 4in1 Copy setting is selected.

- 1 Press the [Utility] key.
- 2 Touch [User's Choice].
- 3 Touch [2/6], and then touch [Multiple-in-1 and Booklet Copy Zoom].

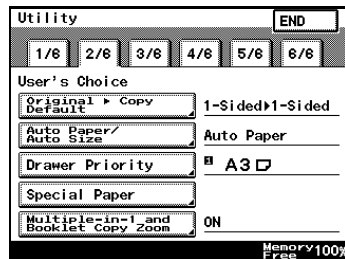

- 4 Touch [ON] or [OFF], and then touch [Enter].
 - If [OFF] is selected, specify the Zoom settings for the 2in1 and 4in1 Copy settings.
- 5 Touch [END] to return to the Utility screen, and then touch [Exit] to return to the Basics screen.

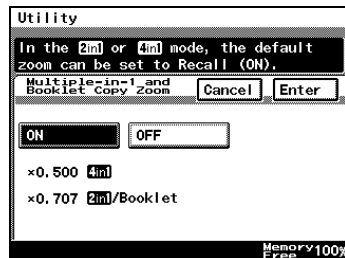

To set the “Energy Save Mode” function

This function is used to specify when the copier automatically enters Energy Saver mode after no operation is performed for the set length of time.

- 1 Press the [Utility] key.
- 2 Touch [User's Choice].
- 3 Touch [3/6], and then touch [Energy Save Mode].

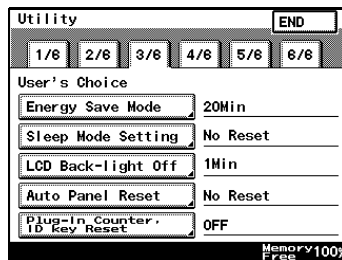

- 4 Press the [C] key to erase the value.
 - Use the 10-Key Pad to specify the desired length of time, and then touch [Enter]. (Specify a length of time between 1 and 240 minutes.)
- 5 Touch [END] to return to the Utility screen, and then touch [Exit] to return to the Basics screen.

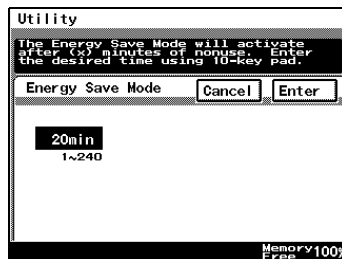

To set the “Sleep Mode Setting” function

This function is used to specify the period of time where there is no input, after which the copier automatically turns the printer heater off.

To display [No Reset], you need to first display [No Reset] in Specifying Administrator Settings. For details, refer to “Administrator Settings” on page 8-6.

- 1 Press the [Utility] key.
- 2 Touch [User’s Choice].
- 3 Touch [3/6], and then touch [Sleep Mode Setting].

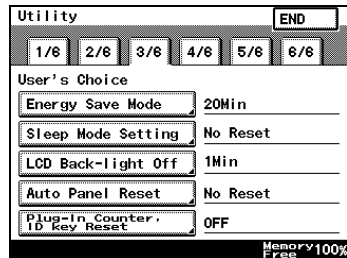

- 4 Press the [C] key to erase the value.

- Use the 10-Key Pad to specify the desired length of time, and then touch [Enter]. (Specify a length of time between 1 and 240 minutes.)
- Selecting the [No Reset] key means that sleep functions will no longer operate.

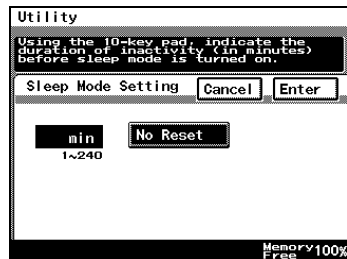

- 5 Touch [END] to return to the Utility screen, and then touch [Exit] to return to the Basics screen.

To set the “LCD Back-light Off” function

This function is used to specify when the backlight for the touch panel automatically goes off after no operation is performed for the set length of time.

- 1 Press the [Utility] key.
- 2 Touch [User's Choice].
- 3 Touch [3/6], and then touch [LCD Back-light Off].

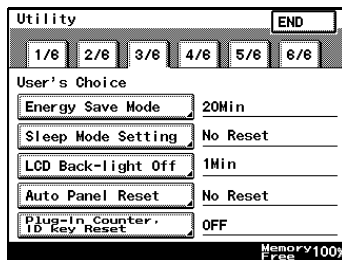

- 4 Press the [C] key to erase the value.
 - Use the 10-Key Pad to specify the desired length of time, and then touch [Enter]. (Specify a length of time between 1 and 240 minutes.)



Tip

If the preheat and sleep settings are short because of the LCD Back-light being set to off, then the Backlight will be turned off after the specified preheat or sleep time.

- 5 Touch [END] to return to the Utility screen, and then touch [Exit] to return to the Basics screen.

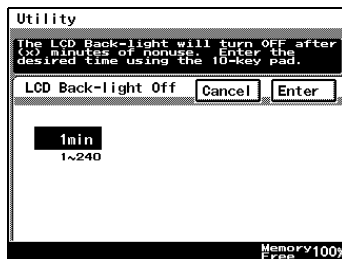

To set the “Auto Panel Reset” function

This function is used to specify when the Basics screen is automatically displayed if no operation is performed while a program or settings are being specified.

- 1 Press the [Utility] key.
- 2 Touch [User's Choice].
- 3 Touch [3/6], and then touch [Auto Panel Reset].

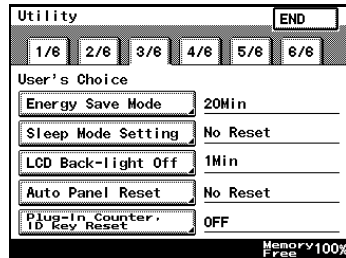

- 4 Select the desired length of time until the Basics screen is displayed, and then touch [Enter].
 - The length of time until the Basics screen is displayed can be set to 30 seconds, 1, 2, 3 or 5 minutes, or “No Reset”.

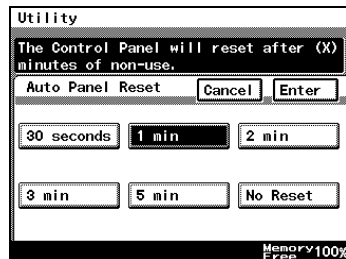

- 5 Touch [END] to return to the Utility screen, and then touch [Exit] to return to the Basics screen.

To set the “Plug-In Counter, ID key Reset” function

Pressing the [Access] key when specifying administrator settings specifies whether or not to return to default settings, with the exception of when the data controller magnetic card is removed.

- 1 Press the [Utility] key.
- 2 Touch [User's Choice].
- 3 Touch [3/6], and then touch [Plug-In Counter, ID key Reset].

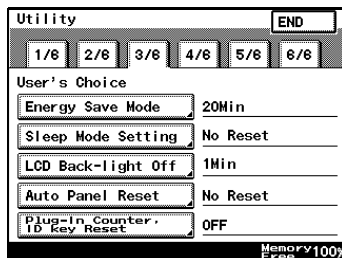

- 4 Touch [ON] or [OFF], and then touch [Enter].
- 5 Touch [END] to return to the Utility screen, and then touch [Exit] to return to the Basics screen.

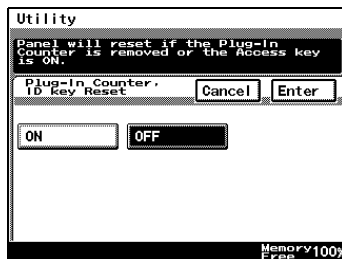

To set the “4in1 Copy Order” function

This function is used to specify the page orientation for making 4in1 copies.

- 1 Press the [Utility] key.
- 2 Touch [User's Choice].
- 3 Touch [4/6], and then touch [4in1 Copy Order].

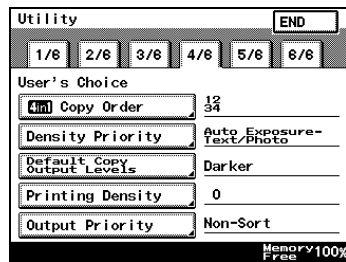

- 4 Select the page orientation for making 4in1 copies, and then touch [Enter].
- 5 Touch [END] to return to the Utility screen, and then touch [Exit] to return to the Basics screen.

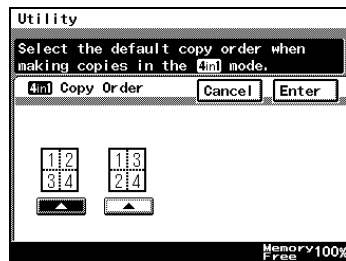

To set the “Density Priority” function

This specifies the default printing density / copy mode settings.

- 1 Press the [Utility] key.
- 2 Touch [User’s Choice].
- 3 Touch [4/6], and then touch [Density Priority].

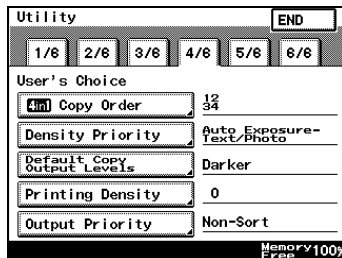

- 4 Select the desired settings, and then touch [Enter].
 - The default Output Density can be set to either [Auto] or [Manual].
 - The default Original Image Type can be set to [Text], [Photo] or [Text/Photo].

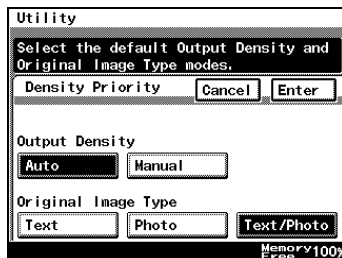

- 5 Touch [END] to return to the Utility screen, and then touch [Exit] to return to the Basics screen.

To set the “Default Copy Output Levels” function

This specifies the auto and manual default printing density level settings.

- 1 Press the [Utility] key.
- 2 Touch [User's Choice].
- 3 Touch [4/6], and then touch [Default Copy Output Levels].

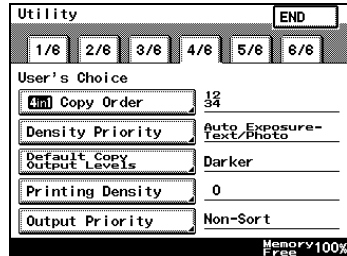

- 4 Select the desired settings, and then touch [Enter].
 - The default Auto density level can be set to [Lighter], [Normal] or [Darker].
 - The default Manual density level can be adjusted by one level at a time.

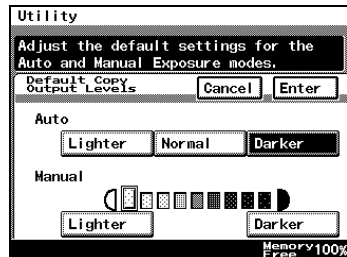

- 5 Touch [END] to return to the Utility screen, and then touch [Exit] to return to the Basics screen.

To set the “Printing Density” function

This specifies the default printing density level settings from -2 to 2, in 5 steps.

- 1 Press the [Utility] key.
- 2 Touch [User’s Choice].
- 3 Touch [4/6], and then touch [Printing Density].

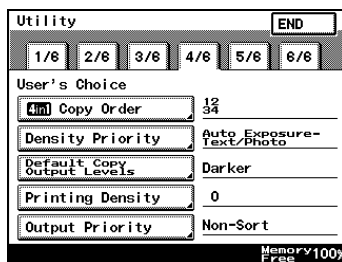

- 4 Select the desired settings, and then touch [Enter].
- 5 Touch [END] to return to the Utility screen, and then touch [Exit] to return to the Basics screen.

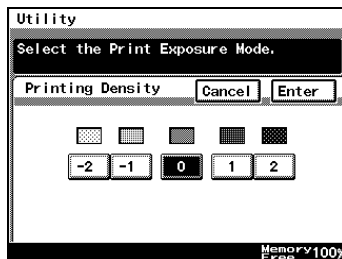

To set the “Output Priority” function

This specifies the default finishing modes that are selected by priority.

- 1 Press the [Utility] key.
- 2 Touch [User's Choice].
- 3 Touch [4/6], and then touch [Output Priority].

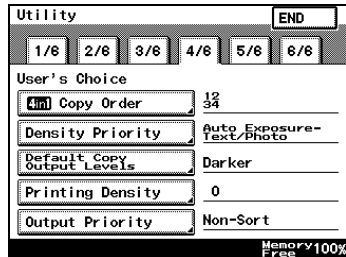

- 4 Select the desired settings, and then touch [Enter].
- 5 Touch [END] to return to the Utility screen, and then touch [Exit] to return to the Basics screen.

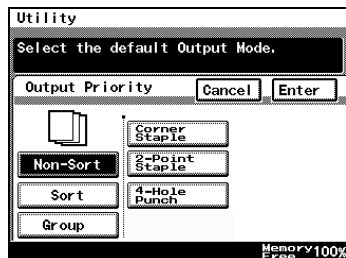

To set the “Intelligent Sorting” function

This function is used to specify whether or not the “Sort” and the “Non-Sort” settings are automatically selected according to the number of pages in the document.

- 1 Press the [Utility] key.
- 2 Touch [User’s Choice].
- 3 Touch [5/6], and then touch [Intelligent Sorting].

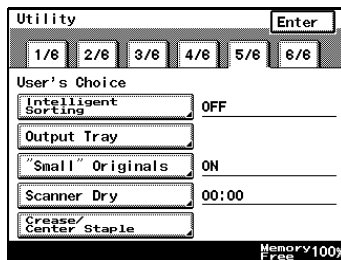

- 4 Touch [ON] or [OFF], and then touch [Enter].
 - If [ON] is selected, the “Non-Sort” setting is automatically selected when a document consisting of only one page is loaded into the duplexing document feeder, and the “Sort” setting is automatically selected when a document consisting of two or more pages is placed in the duplexing document feeder.
- 5 Touch [END] to return to the Utility screen, and then touch [Exit] to return to the Basics screen.

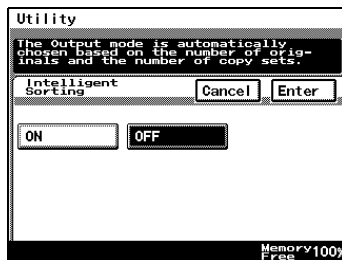

To set the “Output Tray” function (optional)

This function is used to specify how copies and computer printouts are separated and which output tray they are assigned to.



Tip

[Output Tray] only appears if the finisher or the job separator is installed.

- 1 Press the [Utility] key.
- 2 Touch [User's Choice].
- 3 Touch [5/6], and then touch [Output Tray].

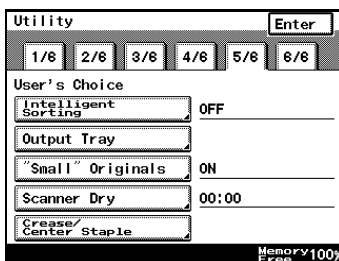

- 4 Select the appropriate output tray settings, and then touch [Enter].
- 5 Touch [END] to return to the Utility screen, and then touch [Exit] to return to the Basics screen.

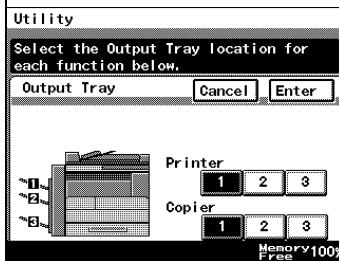
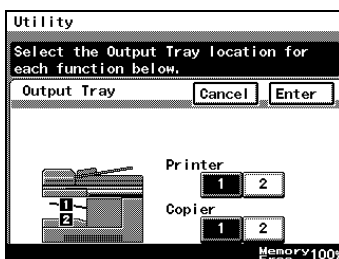

To set the “Small” Originals” function

This function is used to specify whether or not a small-sized original can be copied when the [Start] key is pressed.

- 1 Press the [Utility] key.
- 2 Touch [User’s Choice].
- 3 Touch [5/6], and then touch [“Small” Originals].

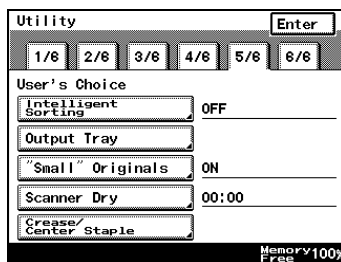

- 4 Touch [ON] or [OFF], and then touch [Enter].
 - If [ON] is selected, a copy can be made using the specified paper.
 - If [OFF] is selected, a message appears, indicating that the paper should be selected.

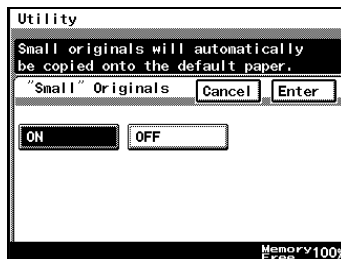

- 5 Touch [END] to return to the Utility screen, and then touch [Exit] to return to the Basics screen.

To set the “Scanner Dry” function

The automatic scanner dry function may be set in order to prevent condensation on the scanner resulting from sudden temperature changes.

- 1 Press the [Utility] key.
- 2 Touch [User's Choice].
- 3 Touch [5/6], and then touch [Scanner Dry].

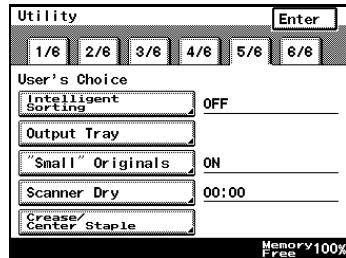

- 4 Use the 10-Key Pad to specify the time when scanner drying begins, and then touch [Enter].
 - Specify the time in the 24-hour format.
 - To erase the value, press the [C] key.

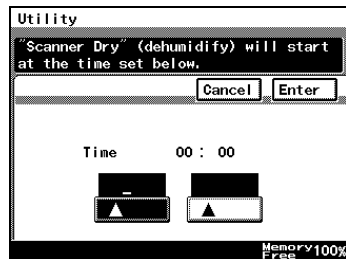

- 5 Touch [END] to return to the Utility screen, and then touch [Exit] to return to the Basics screen.

To set the “Crease/Center Staple” function (Only when the finisher or saddle kit are installed)

When the optional saddle kit (including the finisher) is installed, this controls the offset for creases created using the booklet creation mode, and for any specified center staples.

- 1 Press the [Utility] key.
- 2 Touch [User's Choice].
- 3 Touch [5/6], and then touch [Crease/Center Staple].

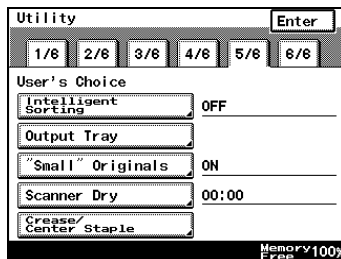

- 4 Touch the arrow keys to adjust the setting, and then touch [Enter].
- 5 Touch [END] to return to the Utility screen, and then touch [Exit] to return to the Basics screen.

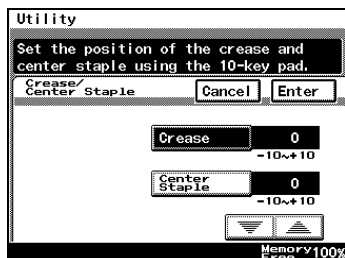

To set the “Density (ADF only)” function (Only when the duplexing document feeder is installed)

This function is used to adjust the density level when the optional duplexing document feeder is used.

- 1 Press the [Utility] key.
- 2 Touch [User's Choice].
- 3 Touch [6/6], and then touch [Density (ADF only)].

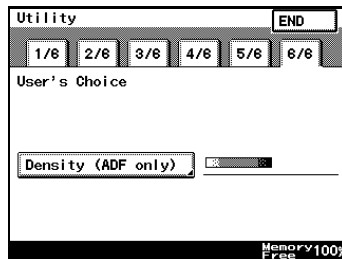

- 4 Select the desired default setting, and then touch [Enter].
 - The setting on the left is most appropriate for scanning normal documents (such as those created with a word processor).
 - The setting on the right is most appropriate for scanning faint document (such as those written with pencil).

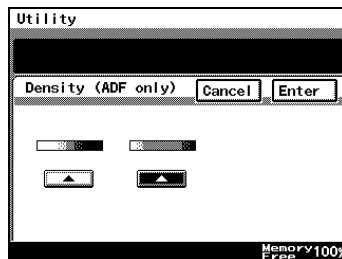

- 5 Touch [END] to return to the Utility screen, and then touch [Exit] to return to the Basics screen.

7.4 Registering an Image Stamp

Before the Auxiliary function “Image Stamping” can be used, an image must be registered. A maximum of five images can be registered. For details on using the “Image Stamping” function, refer to ““Image Stamping” Function” on page 6-17.



Note

The optional hard disk must be installed.

To register an image stamp

- 1 Press the [Utility] key.
- 2 Touch [User Set].
- 3 Touch [Image Mem. Input].

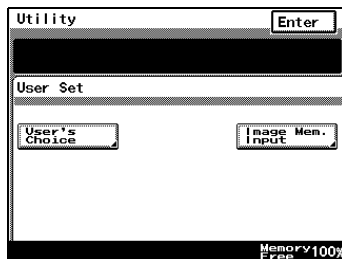
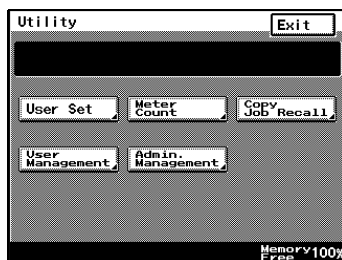

- 4 Touch [Input], and then touch desired registration key.
 - To erase a stored image, touch [Delete], and then touch the number from where you wish to delete the image.
 - To check a stored image, touch [Check], and then touch the number where the image that you wish to check is stored.

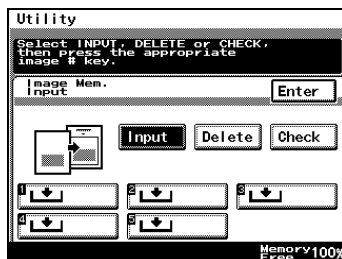

- 5 Select the size of the image document.
Touch [Enter].
To continue scanning a standard-sized image document, skip to step 9.

- To scan a non-standard-sized image document, touch [Custom Size].

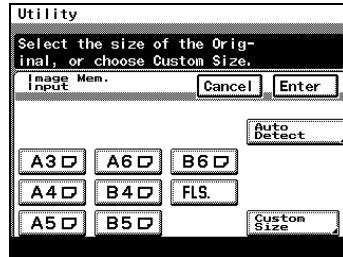

- 6 Press the [C] key to erase the current value, and then use the 10-Key Pad to type in the length of side X for the image document (between 25 and 432 mm).
Touch [Y], and then press the [C] key to erase the current value.
Use the 10-Key Pad to type in the length of side Y for the image document (between 25 and 297 mm).

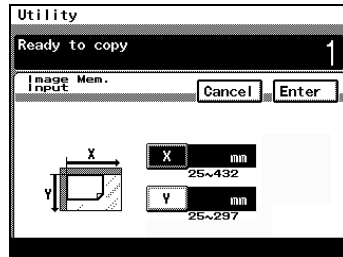

- 7 Touch [Enter].
- 8 Position the document on the glass, and then select the orientation of the document.
- 9 Press the [Start] key.
The image is scanned.
The image stamp is registered.

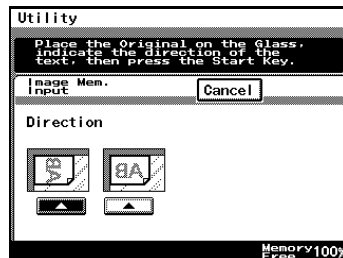

7.5 Viewing Counters (“Meter Count” Function)

With the “Meter Count” function, the following counters can be viewed.

Counter	Function
Total counter	This counter shows the total number of copies and printouts made since the copier was installed.
Copier Total counter	This counter shows the total number of copies made.
Copier Size counter	This counter shows the total number of copies made on the specified paper size. (The paper size that is counted should be set at the service center)
Copier 2-Sided counter	This counter shows the total number of double-sided copies made.
Printer Total counter	This counter shows the total number of printouts made.
Printer Size counter	This counter shows the total number of computer printouts made on the specified paper size. (The paper size that is counted should be set at the service center)
Printer 2-Sided counter	This counter shows the total number of double-sided computer printouts made.
Scanner counter	This counter shows the total number of pages that have been scanned.
Account Total counters	These counters show the total number of copies and printouts made for each account currently registered. (A counter for each registered account is listed.)

To view the counters

- 1 Press the [Utility] key.
- 2 Touch [Meter Count].
- 3 After checking the various counters, touch [Exit].
 - There are two Meter Count screens. To view the other screen, touch [Next].
- 4 Touch [Exit] to return to the Basics screen.

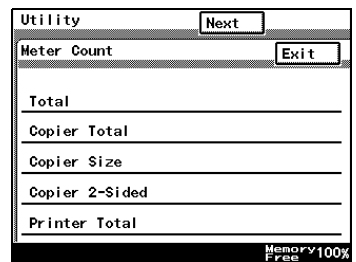

7.6 Using Copy Programs

Up to 10 sets of copy settings can be stored as copy programs.

To store a copy program

- 1 Press the [Mode Check] key.

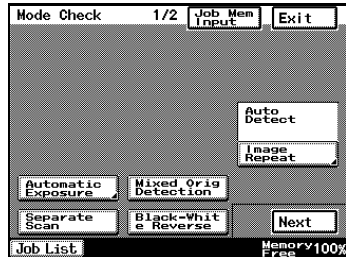

- 2 Touch [Job Mem Input], and then touch the number where you wish to store the copy program.

- Number buttons on which  does not appear have already been assigned a copy program. If a button that has already been programmed is selected, the previously assigned copy program is deleted.

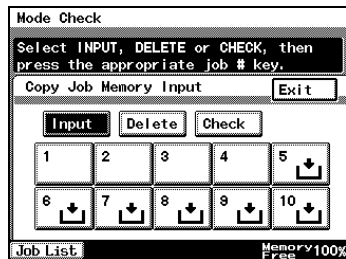

- 3 Touch [Check], and then touch a number button.

- 4 Check the programmed settings.

- To display screen 2/2, touch [Next]. To return to screen 1/2, touch [Back].

- 5 Touch [Enter] to return to the Mode Check screen, and then touch [Exit] to return to the Basics screen.

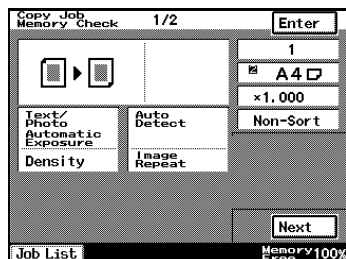

To delete a copy program

Individual copy programs can be deleted.

- 1 Press the [Mode Check] key.
- 2 Touch [Job Mem Input].

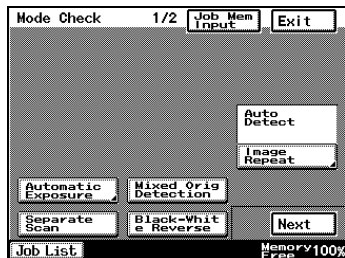

- 3 Touch the number button assigned with the copy program that you wish to delete, and then touch [Delete].
 - The copy program is deleted, and  appears on the button.
- 4 Touch [Exit] to return to the Mode Check screen, and then touch [Exit] to return to the Basics screen.

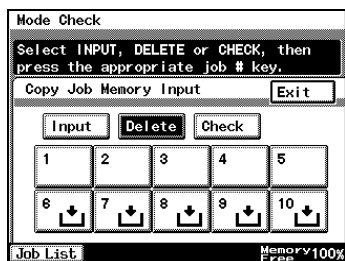

To use a copy program

- 1 Press the [Utility] key.
- 2 Touch [Copy Job Recall].

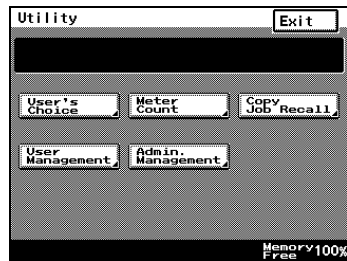

- 3 Touch the button assigned with the copy program that you wish to use.
 - Only buttons that have been assigned a copy program are displayed.

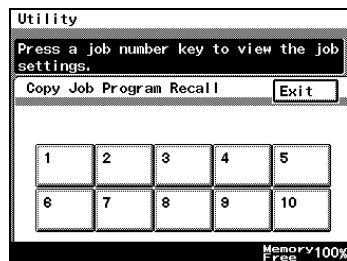

- 4 Check the settings, and then touch [Enter].
- 5 Set the document, and press the [Start] key.

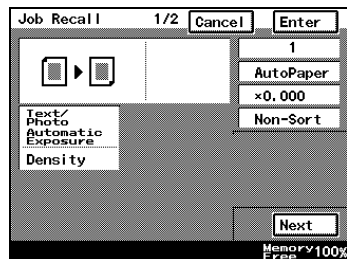

7.7 User Management Functions

The following settings can be specified or operations can be performed from the User Management screen.

- Confirmation beep volume
- Alarm beep volume
- Touch panel cleaning
- Dehumidifying
- Toner replenishing

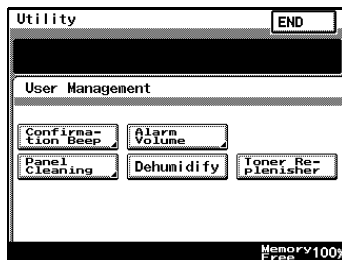

To adjust beep volumes (“Confirmation Beep” and “Alarm Volume” functions)

You can adjust the volume of the electronic beep used when pressing a key on the copier, or beeps issued to indicate alarms.

The following procedure describes how to adjust the volumes of two types of beeps. Additionally, beep volumes can be easily adjusted per user.

- ✓ [Confirmation Beep]: This function is used to adjust the volume of the beep that is sounded when a touch panel button is touched. (Default setting: 3)
- ✓ [Alarm Volume]: This function is used to adjust the volume of the alarm that is sounded when a paper misfeed occurs or an incorrect operation is specified. (Default setting: 3)

- 1 Press the [Utility] key.
- 2 Touch [User Management], and then touch the button for the beep that you wish to adjust.
- 3 Touch the arrow keys to select the desired volume, and then touch [Enter].
- 4 Touch [END] to return to the Utility screen, and then touch [Exit] to return to the Basics screen.

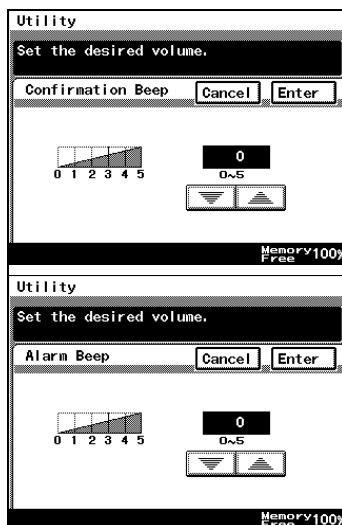

To clean the touch panel (“Panel Cleaning” function)

By setting panel cleaning, you can clean the panel without accidentally pressing panel buttons.

- 1 Press the [Utility] key.
- 2 Touch [User Management], and then touch [Panel Cleaning].
 - To cancel the function, press the [Panel Reset] key.

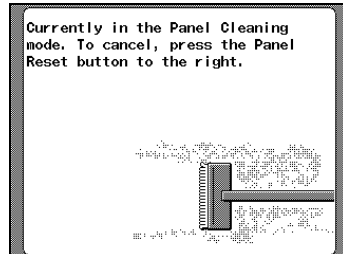

To dehumidify the duplexing document feeder (“Dehumidify” function)

When there are rapid changes in the temperature of a room, or high humidity, condensation may occur on the surface of the photosensitive receptor drum or the scanner on the copier, resulting in blurred images. When this occurs, use the “Dehumidify” function (Approximately 5 minutes) to remove the condensation.

If you wish to remove condensation at a set time every day. For details, refer to “To set the “Scanner Dry” function” on page 7-28.



Note

Condensation: a phenomenon where atmospheric water collects on the photosensitive receptor drum or the scanner, forming water droplets.

Photosensitive receptor drum: the part that contacts the film copy.



Note

When you wish to remove condensation from the photosensitive receptor drum, contact your local technical representative.

You can still copy if there during dehumidifying. (however, dehumidifying will be interrupted.)

To specify a time to perform the dehumidifying operation, refer to page 7-28.

- 1 Press the [Utility] key.
- 2 Touch [User Management], and then touch [Dehumidify].
The dehumidifying operation begins.

To replenish the toner (“Toner Replenisher” function)

This function is used when copies are temporarily faint although plenty of toner remains, such as immediately after the toner bottle is replaced or after copying a large quantity of documents with large printed areas. If this occurs, toner can be replenished.

- 1 Press the [Utility] key.
- 2 Touch [User Management], and then touch [Toner Replenisher].
The toner is replenished.

8 Administrator Management Operations

8.1 Administrator Management Screens

To display the Administrator Management screens

This explains the method for displaying the Administrator Management screens.

- 1 Press the [Utility] key.
- 2 Touch [Admin. Management].

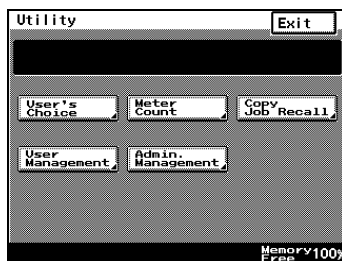

- 3 Use the 10-Key Pad to type in the 8-digit administrator code (Admin. Password).



Note

If the administrator code (Admin. Password) is incorrectly entered, the message "Incorrect administrator code. Try again." appears accompanied by a beeping sound. Follow the instructions in the message that appears and type in the correct administrator code.

If the administrator code (Admin. Password) is incorrectly entered three times, the message "The Admin. Code is now disable due to unauthorized access cannot Admin. Mode." appears, access to Administrator mode is denied, and the password will not be accepted. To allow access to Administrator mode, turn the machine off, then on again.



Keep the administrator code (Admin. Password) in a safe place hidden from the general user.

- 4 Touch [Admin. 1] or [Admin. 2] to display the desired screen.
 - For details on the Administrator Management 1 screen, refer to page 8-3. For details on the Administrator Management 2 screen, refer to page 8-20.

- 5 From the screen that appeared, touch the key for the operation that you wish to perform or the function whose setting you wish to specify.



Note

When specifying [1000 Accounts] or [OFF] in the account management mode, neither the [Account Reg] nor the [Account Counter] keys will be displayed. Refer to "To set the Account Management Mode" on page 8-11 for details.

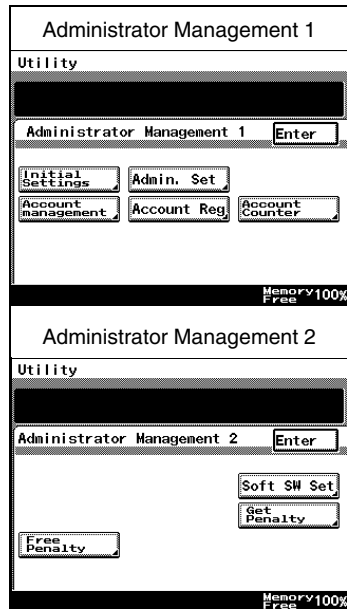
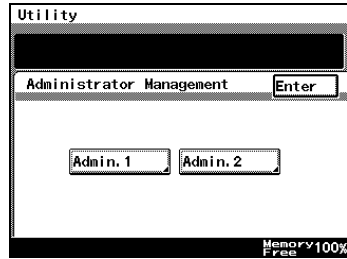

8.2 Initial Settings

Specify the date and time

Specify the date and time so that they will be correctly recorded in the reports.

To set the date and time

- 1 Follow the procedure described in *“To display the Administrator Management screens” on page 8-1* to display the Administrator Management screen.
- 2 Touch [Admin. 1], and then touch [Initial Settings].
- 3 Touch [Date/Time Set].

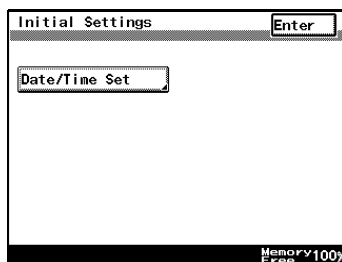

- 4 Touch [TimeDate].



- 5 Use the 10-Key Pad to type in the current date and time, and then touch [Enter].
 - To re-enter the entered value, press the [C] key.
 - Touch the button for the year, month, day, hour or minutes, and then use the 10-Key Pad to enter the value.

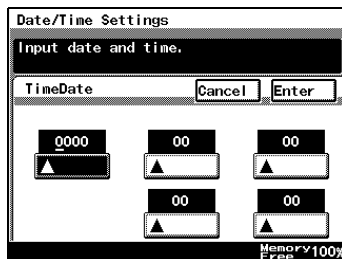

- Enter four digits for the year.
 - Enter the time in the 24-hour format.
- 6** Continue touching [Enter] to return to the Utility screen, and then touch [Exit] to return to the Basics screen.

Specify the time zone

Specify the time difference from Greenwich Mean Time, which is added to the header of mails that are sent.

To set the time zone

- 1 Follow the procedure described in “To display the Administrator Management screens” on page 8-1 to display the Administrator Management screen.
- 2 Touch [Admin. 1], and then touch [Initial Settings].
- 3 Touch [Date/Time Set].



- 4 Touch [TimeZone].

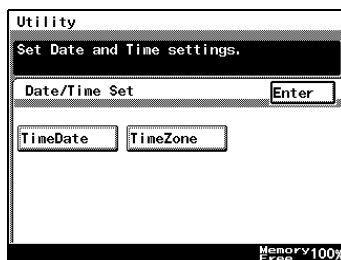

- 5 Touch the arrow keys to adjust the setting, and then touch [Enter].
 - The time difference can be adjusted in 30-minute intervals.
- 6 Continue touching [Enter] to return to the Utility screen, and then touch [Exit] to return to the Basics screen.

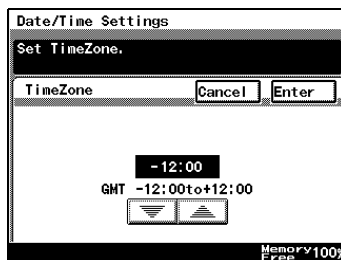

8.3 Administrator Settings

Changing the administrator access code

This explains the method to specify or change the administrator access code.

To set the administrator access code

- 1 Follow the procedure described in “To display the Administrator Management screens” on page 8-1 to display the Administrator Management screen.
- 2 Touch [Admin. 1], and then touch [Admin. Set].
- 3 Touch [Administrator Code Input].

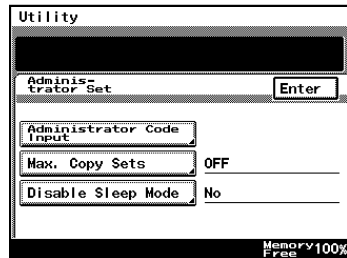

- 4 Touch [Current Code], and then use the 10-Key Pad to type in the currently specified 8-digit administrator code (Admin. Password).

- Press the [C] key to erase all entered text.
- To return to the previous screen, touch [Cancel].

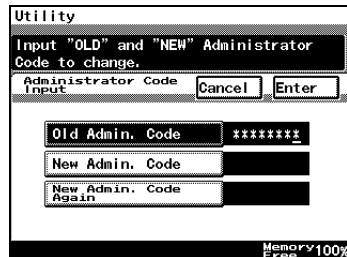

Note

If the entered administrator code is incorrect, the message “Incorrect code and new administrator. Input administrator code.” appears. Type in the correct administrator code.

When the “Get Penalty” function is set to “ON”, incorrectly typing the administrator code is counted as an incorrect attempt to access the machine. After three incorrect attempts, the Utility screen is displayed, access to Administrator mode is denied, and the administrator code (administrator password) will not be accepted.

To allow access to Administrator mode, turn the machine off, then on again.

- 5 Touch [New Code], and then use the 10-Key Pad to type in the new 8-digit administrator code (Admin. Password).

- Press the [C] key to erase all entered text.
- To return to the previous screen, touch [Cancel].



Note

If the entered administrator code does not have 8 digits, the message "Incorrect code and new administrator. Input administrator code." appears. Type in an 8-digit administrator code.

- 6 Touch [Retype New Code], and then use the 10-Key Pad to retype the new 8-digit administrator code (Admin. Password).

- Press the [C] key to erase all entered text.
- To return to the previous screen, touch [Cancel].



Note

If the entered administrator code does not have 8 digits, the message "Incorrect code and new administrator. Input administrator code." appears. Type in an 8-digit administrator code.

- 7 Touch [Enter].

Copy Number Limits

This is used to specify the maximum number of copies that can be printed.

To specify the maximum number of copies that can be printed

- 1 Follow the procedure described in "To display the Administrator Management screens" on page 8-1 to display the Administrator Management screen.
- 2 Touch [Admin. 1], and then touch [Admin. Set].
- 3 Touch [Max. Copy Sets].

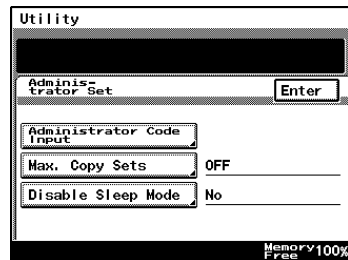

- 4 Use the 10-Key Pad to specify the maximum number of copies, and then touch [Enter].
 - Numbers between 1 and 99 can be specified.
- 5 Continue touching [Enter] to return to the Utility screen, and then touch [Exit] to return to the Basics screen.

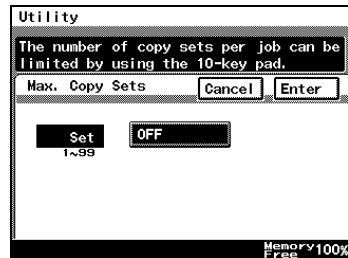

Disable Sleep Mode

This parameter is used to disable the Sleep function, which automatically turns off the printer heater after no operation is performed for a specified length of time.

To disable the Sleep mode

- 1 Follow the procedure described in *“To display the Administrator Management screens” on page 8-1* to display the Administrator Management screen.
- 2 Touch [Admin. 1], and then touch [Admin. Set].
- 3 Touch [Disable Sleep Mode].

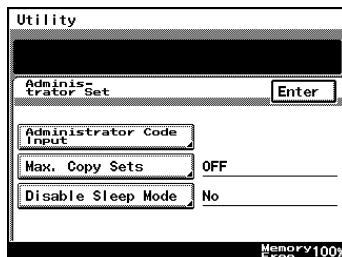

- 4 Touch [Yes] or [No], and then touch [Enter].
 - If [Yes] is selected, [No Reset] appears in the screen for the “Sleep Mode Setting” function, which is available from the User’s Choice screen.

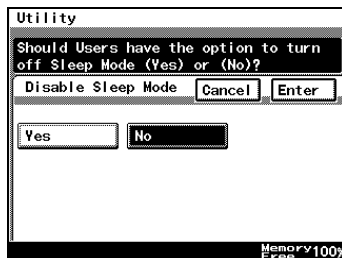

- 5 On the User’s Choice [3/6] sleep mode setting screen, select [No].
- 6 Continue touching [Enter] to return to the Utility screen, and then touch [Exit] to return to the Basics screen.

8.4 Account Management Settings

Account Management Mode

The number of copies and the number of prints can be managed per account. Additionally, users can be limited by management of accounts.

- [100 Accounts 1]
Enter the security code to make copies. Alternatively, the following can be configured per account.
 - Account name: program or change the account name
 - Security code: program or change the security code
 - Account number: program or change the account number
 - Print upper limit: limit the maximum number of prints that can be made for each account
 - Total counter: displays the total counter value for each account. Additionally, clears the counter value
- [100 Accounts 2]
Copies can be made whether or not they have entered the security code. Alternatively, the following can be configured per account by entering the registered access code.
 - Account name: program or change the account name
 - Registered access code: program or change the registered access code
 - Account number: program or change the account number
 - Print upper limit: limit the maximum number of prints that can be made for each account
 - Total counter: displays the total counter value for each account. Additionally, clears the counter value
- [1000 Accounts]
Enter the account number to make copies. Additionally, the following can be configured per account.
 - Total counter: displays the total counter value for each account. Additionally, clears the counter value

To set the Account Management Mode

You can manage the number of pages that can be copied per account.

- 1 Follow the procedure described in "To display the Administrator Management screens" on page 8-1 to display the Administrator Management screen.
- 2 Touch [Admin. 1], and then touch [Account management].
- 3 Touch [Copy Track Mode].

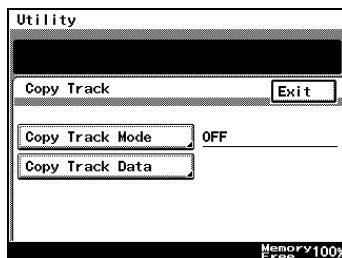

- 4 Select the desired account information methods, and touch the [Enter] key.

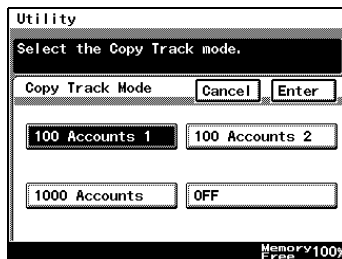

- 5 This will set the default account information. Select [Yes], and touch [Enter].



Note

When programming or changing account information data, please set the default account information data. However, depending on the currently specified account information method, the default screen may not be displayed.

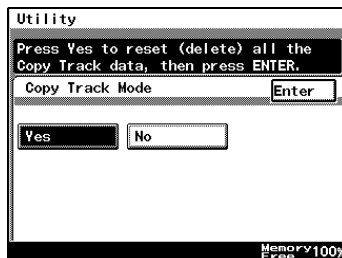

**Note**

When setting [100 Accounts 1] or [100 Accounts 2], please program account names, etc. for each account. Please refer to "Account Registration" for details.

- 6 Continue touching [Enter] to return to the Utility screen, and then touch [Exit] to return to the Basics screen.

**Note**

Only when setting [100 Accounts 1] or [100 Accounts 2], will the [Account Reg] or the [Account Counter] be displayed on the Admin.1 screen.

Account Information data

When carrying out account management settings, you can confirm usage for each account, or clear counter values. Alternatively, when carrying out 100 Account Management, you can change account numbers, print maximum limits, and access codes. You can also clear all counter values at once.

To print account information data

- 1 Follow the procedure described in *"To display the Administrator Management screens"* on page 8-1 to display the Administrator Management screen.
- 2 Touch [Admin. 1], and then touch [Account management].
- 3 Touch [Copy Track Data].

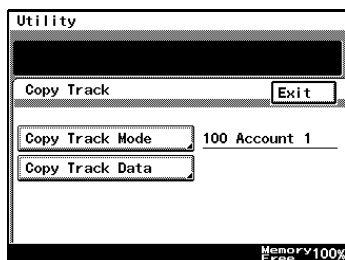

- 4 Set A4 L paper in the 1st paper drawer, then press the [Start] key. Account management data is printed.
- 5 Continue touching [Enter] to return to the Utility screen, and then touch [Exit] to return to the Basics screen.

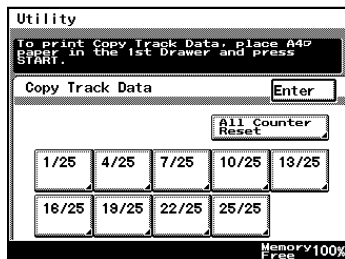

Clear all counters

- 1 Follow the procedure described in "To display the Administrator Management screens" on page 8-1 to display the Administrator Management screen.
- 2 Touch [Admin. 1], and then touch [Account management].
- 3 Touch [Copy Track Data].
- 4 Select the page number of the account you wish to clear.



Tip

If you wish to clear all the total counters accounts at once, touch [All Counter Reset].

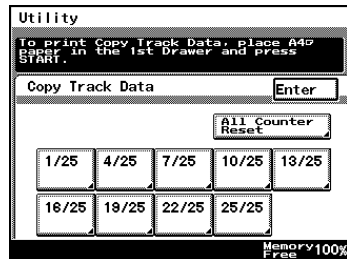

- 5 Select the total keys of the accounts you wish to clear, and press the [C] key.



Tip

If you wish to cancel clearing of accounts, press the [Interrupt] key.

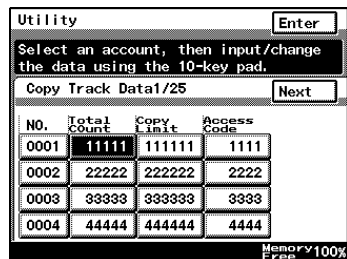

If you wish to clear the total counter of other accounts, repeat steps 4 and 5.

- 6 Continue touching [Enter] to return to the Utility screen, and then touch [Exit] to return to the Basics screen.

Changing Account Information

- 1 Follow the procedure described in *"To display the Administrator Management screens"* on page 8-1 to display the Administrator Management screen.
- 2 Touch [Admin. 1], and then touch [Account management].
- 3 Touch [Copy Track Mode].

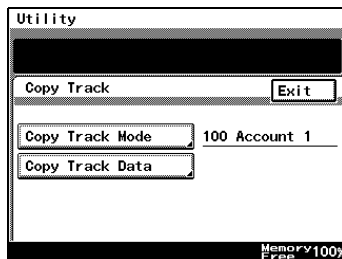

- 4 Select the page number of the account you wish to change.

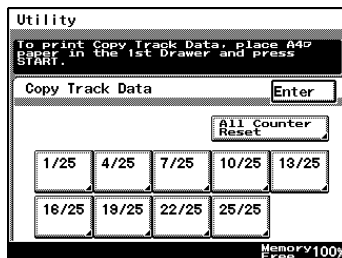

- 5 Select the key for the page you wish to change, and press the [C] key.
- 6 Use the 10-Key Pad to type in the value you wish to change.
- 7 Continue touching [Enter] to return to the Utility screen, and then touch [Exit] to return to the Basics screen.

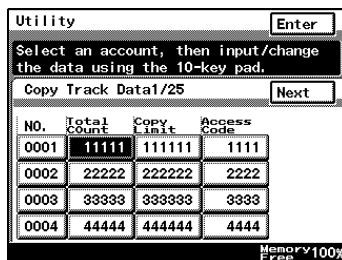

8.5 Setting Account Registration

Account Registration

Accounts can be registered for departments in a company or for individuals. The number of prints can be restricted for each account, access codes specified, or unauthorized use of the copier restricted.

100 account management is required in Administrator Management Mode. For details, refer to *“To set the Account Management Mode” on page 8-11.*

To register accounts

- 1 Follow the procedure described in *“To display the Administrator Management screens” on page 8-1* to display the Administrator Management screen.
- 2 Touch [Admin. 1], and touch [Account Reg].
- 3 Select the account key to program or change.

- 4 Touch [Account Name].

- 5 To enter the name of the account, use the character buttons that appear in the touch panel.

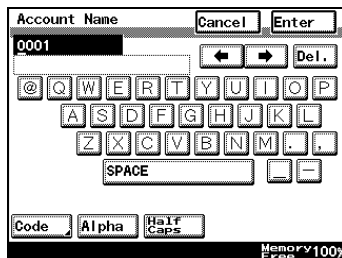

- 6 Touch [Enter].
- 7 Touch [Access Number], and enter the access code for the account.

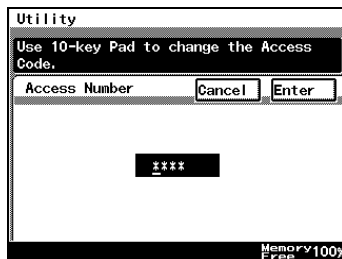

- 8 Touch [Enter].
- 9 Touch [Account Number], and enter the account number using the 10-Key Pad.

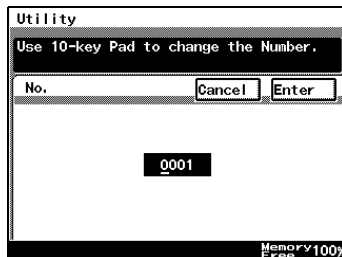

- 10 Touch [Enter].

- 11 Touch [Max. Print Page], and enter the upper print limit using the 10-Key Pad.

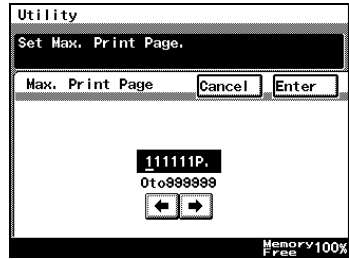

- 12 Touch [Enter].

**Tip**

Where you wish to change the programmed details, repeat from step 3, entering the correct details.

To delete programmed details, at step 4, press the [Delete] key.

- 13 Continue touching [Enter] to return to the Utility screen, and then touch [Exit] to return to the Basics screen.

Account Counter

The number of prints made by each account can be checked.

To check the number of prints made by each account

- 1 Follow the procedure described in *“To display the Administrator Management screens” on page 8-1* to display the Administrator Management screen.
- 2 Touch [Admin. 1], and then touch [Account Counter].
- 3 Touch the button for the account whose counter you wish to view, and then touch [Enter].

Account Counter		Enter
Select the Account.		
1	2	3
4	5	6
7	8	9
10		
BOSTON	:0001	JAPAN
		:0002
NEW YORK	:0003	ARIZONA
		:0004
	:	:
	:	:
	:	:
		No.
		Memory 100% Free

- 4 After checking the counter, then touch [Enter].
- 5 Continue touching [Enter] to return to the Utility screen, and then touch [Exit] to return to the Basics screen.

Account Counter		Enter
0001		
Number of Print	011111	
Pages of TX Doc.		
		Memory 100% Free

8.6 Setting Machine Access

Get Penalty

The “Get Penalty” function is used to specify whether (“On”) or not (“Off”) access to Administrator mode, mailbox print jobs and user boxes is monitored.

If the “Get Penalty” function is set to “On”, the number of incorrect attempts to access Administrator mode, mailbox print jobs and user boxes is counted. After three incorrect attempts, access to the machine is denied. To allow Administrator mode to be accessed again, turn the machine off, then on again. However, to allow mailbox print jobs and user boxes to be accessed again, the penalty must be removed. For more details, refer to the Printer Controller User Manual.

To make settings for the “Get Penalty” function

1 Follow the procedure described in “To display the Administrator Management screens” on page 8-1 to display the Administrator Management screen.

2 Touch [Admin. 2], and then touch [Get Penalty].

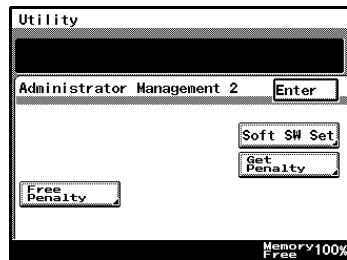

3 To use the “Get Penalty” function, touch [ON]. To stop using the “Get Penalty” function, touch [OFF].

4 Touch [Enter].

- To return to the previous screen, touch [Cancel].

5 Continue touching [Enter] to return to the Utility screen, and then touch [Exit] to return to the Basics screen.

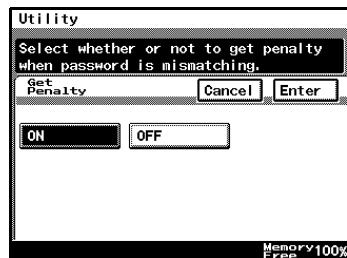

8.7 Configuring Functions (Soft Switches)

Soft switches for functions can be set according to your use.



Note

Do not alter any modes or bits not mentioned in this manual.

Soft Switching Settings	
Mode specification	Specifies the soft switch setting item with 3 digits.
Bit specification	An 8-digit number comprising the mode. Each bit from 0 to 7 is specified with a binary number (0 or 1) to configure functions.
HEX specification	Allows the functions to be set using hexadecimal numbers (a combination of 0 to 9 and A to F). For example, the bit specification of "0011 0000" would be "30" in hexadecimal.

Reference: The table below gives some sample bit (binary) and hexadecimal (16-base) equivalents

Decimal	Bit specification (binary)	HEX specification (hexadecimal)
0	0000 0000	00
1	0000 0001	01
2	0000 0010	02
3	0000 0011	03
4	0000 0100	04
5	0000 0101	05
6	0000 0110	06
7	0000 0111	07
8	0000 1000	08
9	0000 1001	09
10	0000 1010	0A
11	0000 1011	0B
12	0000 1100	0C
13	0000 1101	0D
14	0000 1110	0E
15	0000 1111	0F
16	0001 0000	10
:	:	:
255	1111 1111	FF

Specifying Settings for Resetting Copy Mode with the Duplexing Document Feeder Installed (Mode 429)

Settings can be specified for the time until Copy mode is reset after a copy job scanned using the duplexing document feeder is finished.

Settings at time of purchase

Bit	7	6	5	4	3	2	1	0	
Setting	0	0	1	0	0	0	0	0	(HEX: 00)

How to Set

The grayed out cells are the settings at the time of purchase.

Bit	Details	Setting	Explanation
7, 6		00	* Do not change these bits.
5	Specifies whether or not Copy mode is reset after a copy job scanned using the duplexing document feeder is finished	0	Do not clear
		1	Clear
4, 3, 2, 1, 0		00000	* Do not change these bits.

8.8 Removing Penalties

Free Penalty

If the “Get Penalty” function is set to “ON” and the optional printer controller is installed, the penalty must be removed in order to allow access after incorrect attempts to access mailbox print jobs and mail boxes. For more details, refer to the User Manual for the printer controller.

In addition, to allow access after incorrect attempts to access Administrator mode, turn the machine off, then on again.

9 Copy Paper

9.1 Paper Specifications

Use paper that meets the following specifications.

Paper Types

Paper Type Paper Source, Etc.	Plain Paper	Special Media	Recycled Paper
	56 to 90 g/m ²	91 to 210 g/m ²	60 to 90 g/m ²
Multiple bypass tray	○	○	○
1st paper drawer	○	—	○
2nd paper drawer	○	—	○
3rd paper drawer (LCC*)	○	—	○
3rd paper drawer	○	—	○
4th paper drawer	○	—	○
Double-sided copies	○	—	○

Paper Type Paper Source, Etc.	Special Media			
	Overhead Projector Transparencies	Postcards	Label Sheets	Envelopes
Multiple bypass tray	○	○	○	○
1st paper drawer	—	—	—	—
2nd paper drawer	—	—	—	—
3rd paper drawer (LCC*)	—	—	—	—
3rd paper drawer	—	—	—	—
4th paper drawer	—	—	—	—
Double-sided copies	—	—	—	—

* LCC: Large capacity cabinet

○: Available —: Not available

Paper Sizes

Non-standard-sized paper

Paper Source	Paper Width	Paper Length
Multiple bypass tray	90 mm to 297 mm	140 mm to 432 mm
1st paper drawer	—	—
2nd paper drawer	—	—
3rd paper drawer (LCC*)	—	—
3rd paper drawer	—	—
4th paper drawer	—	—

* LCC: Large capacity cabinet

—: Not available

Standard-sized paper

Paper Size	A3 L	B4 L	A4 L	A4 C	B5 L	B5 C	A5 L	A5 C
Paper Source, Etc.								
Multiple bypass tray	○	○	○	○	○	○	○	○
1st paper drawer	○	○	○	○	○	○	○	—
2nd paper drawer	○	○	○	○	○	○	○	—
3rd paper drawer (LCC*)	—	—	—	○	—	—	—	—
3rd paper drawer	○	○	○	○	○	○	○	—
4th paper drawer	○	○	○	○	○	○	○	—
Double-sided copies	○	○	○	○	○	○	○	—

Paper Size	B6 L
Paper Source, Etc.	
Multiple bypass tray	○
1st paper drawer	—
2nd paper drawer	—
3rd paper drawer (LCC*)	—
3rd paper drawer	—
4th paper drawer	—
Double-sided copies	○

* LCC: Large capacity cabinet

○: Available —: Not available

Paper Capacity

Paper Type Paper Source, Etc.	Plain Paper	Special Media	Recycled Paper
	56 to 90 g/m ²	91 to 210 g/m ²	60 to 90 g/m ²
Multiple bypass tray	150 sheets	100 sheets	150 sheets
1st paper drawer	500 sheets	—	500 sheets
2nd paper drawer	500 sheets	—	500 sheets
3rd paper drawer (LCC*)	2,500 sheets	—	2,500 sheets
3rd paper drawer	500 sheets	—	500 sheets
4th paper drawer	500 sheets	—	500 sheets

Paper Type Paper Source, Etc.	Special Media			
	Overhead Projector Transparencies	Postcards	Label Sheets	Envelopes
Multiple bypass tray	50 sheets	50 sheets	50 sheets	10 sheets
1st paper drawer	—	—	—	—
2nd paper drawer	—	—	—	—
3rd paper drawer (LCC*)	—	—	—	—
3rd paper drawer	—	—	—	—
4th paper drawer	—	—	—	—

* LCC: Large capacity cabinet

—: Not available



Note

The 3rd paper drawer (large capacity cabinet), the 3rd paper drawer and the 4th paper drawer are optional.

If the optional duplex unit is used to make double-sided copies, only plain and recycled paper can be used.

If the optional finisher is used to sort/group, punch holes and staple, only plain paper can be used.

The paper size setting for the 3rd paper drawer (large capacity cabinet) can be changed in order to load Letter-size paper. Contact your service representative to change the paper size setting.

9.2 Unsuitable Paper

The following types of paper should not be used, otherwise decreased print quality, paper misfeeds or damage to the machine may occur.

- Overhead projector transparencies that have already been fed through the machine
Even if the transparency is still blank, do not reuse it.
- Paper that has been printed on by a heat-transfer printer or an inkjet printer
- Paper that is either extremely thick or extremely thin
- Folded, curled, wrinkled, or torn paper
- Paper that has been left unwrapped for a long period of time
- Damp paper
- Perforated paper or paper with punched holes
- Extremely smooth or extremely rough paper, or paper with an uneven surface
- Paper that has been treated, such as carbon-backed, heat-sensitive or pressure-sensitive paper
- Paper that has been decorated with foil or embossing
- Paper of various sizes
- Paper of a non-standard shape (not rectangular)
- Paper that is bound with glue, staples or paper clips
- Paper with labels attached
- Paper with ribbons, hooks, buttons, etc. attached
- Curled or wrinkled paper
- Art paper, coated paper or inkjet printer paper

9.3 Print Area

Any part of the image within the area indicated below is not copied.

- A margin 4 ± 2 mm (at full size) from the leading edge of the paper (A)
- A margin 4 ± 2 mm (at full size) from the trailing edge of the paper (B)
- A margin 4 ± 2 mm (at full size) on both sides of the paper (C)

For details on using the copier to print from a computer when the printer controller is installed, refer to User Manual for the printer controller.

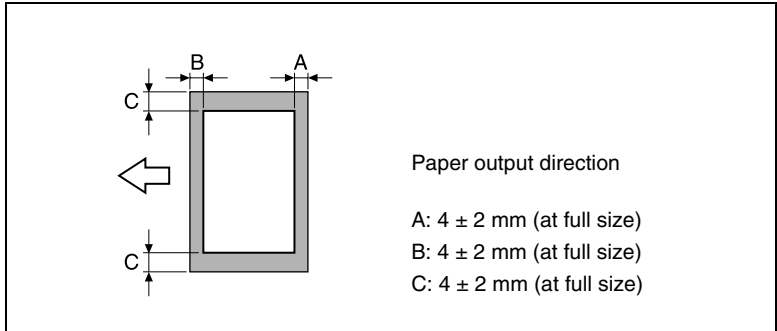

9.4 Paper Storage

Observe the following precautions when storing the paper.

- Store the paper in a location that meets the following requirements.
 - Not exposed to direct sunlight
 - Not exposed to a flame
 - Not exposed to high humidity
 - Not extremely dusty
- Unwrapped paper should be placed in a plastic bag and stored in a cool, dark location.
- Keep paper out of the reach of children.

9.5 Automatically Selecting the Paper Source

If the selected paper drawer runs out of paper while a copy job is being printed and a different paper drawer is loaded with paper meeting the following conditions, the other paper drawer is automatically selected so printing can continue.

If the optional large capacity cabinet (LCC) is installed, a maximum of 3,650 copies (with A4 C paper) can be made continuously.

This feature is convenient when printing a large number of pages or making a large number of copies continuously.

Operating conditions

- The paper is the same size.
- The paper is the same type.
- The paper is positioned in the same orientation.

When making a large number of copies continuously, load all paper drawers with paper meeting the conditions listed above.

Order for Selecting Another Paper Drawer

When a different paper drawer is automatically selected, the next paper drawer in the following list is chosen.

1st paper drawer ⇨ 2nd paper drawer ⇨ 3rd paper drawer ⇨ 4th paper drawer ⇨ Multiple bypass tray



Note

When setting special media such as overhead projector transparencies or label sheets into the Multiple Bypass Tray, the auto tray change function may be started, and may supply the wrong paper. We recommend that you make selections for special media in the User's Choice Special Settings. For details, refer to User's Choice Settings in the Advanced Operations volume of the User Manual.

9.6 Loading Paper

While loading paper, be sure to observe the following precautions.

- If the paper is curled, flatten it before loading it.
- Do not load so much paper that the top of the stack is higher than the ▼ mark or exceeds the specified number of sheets.
- Make sure that the paper guides are pushed up against the edges of the paper.
- When loading additional paper, remove any paper remaining in the drawer, place it on top of the new paper, and then align the paper in the stack well before loading it into the drawer.

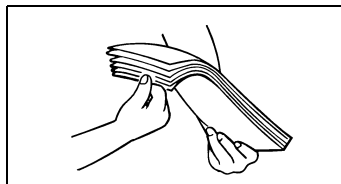
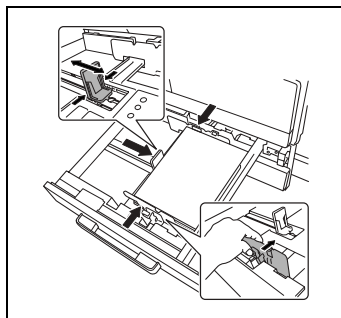
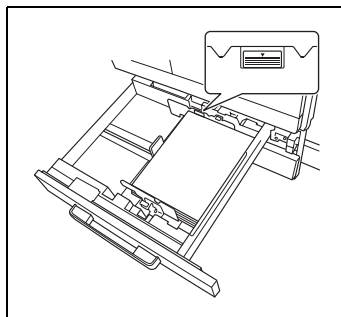
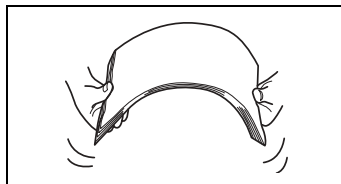

Tip

We recommend replenishing the paper only after all of the paper in the drawer has been used.

Loading Paper Into the 1st/2nd/3rd/4th Paper Drawer

Load paper into the 1st or 2nd paper drawer or the optional 2 way paper feed cabinet and paper feed cabinet, (3rd or 4th paper drawer) as described below.

- 1 Pull out the paper drawer to be loaded with the paper.
- 2 Slide the paper guides to fit the size of the paper to be loaded.



Note

Make sure that the paper guides fit firmly in their slots.

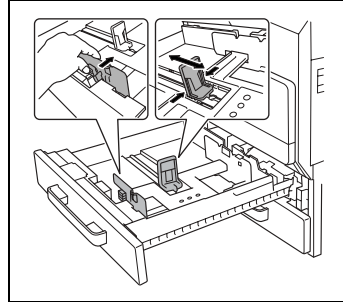

- 3 Load the paper into the drawer so that the front side of the paper (the side facing up when the package was unwrapped) faces up.



Note

Be careful not to touch the mylar.

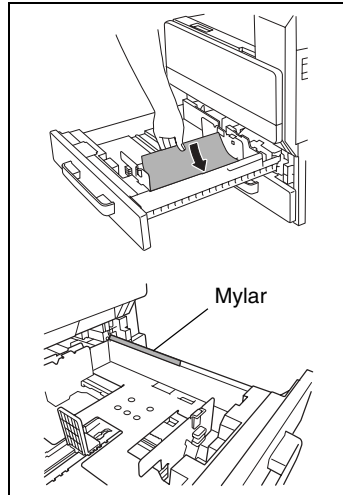

- 4 Re-adjust the paper guides to fit the size of the paper.
- 5 Close the paper drawer.

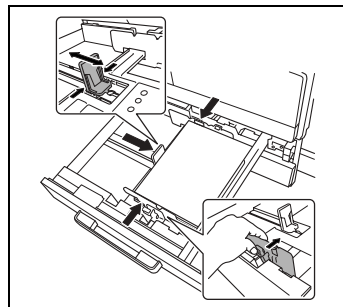

Loading Paper Into the Large Capacity Cabinet

Load paper into the large capacity cabinet as described below.

- 1 Press the drawer release button.



Note

When the power is turned off, the paper supply cassette can not be released, even by pushing the drawer release button.

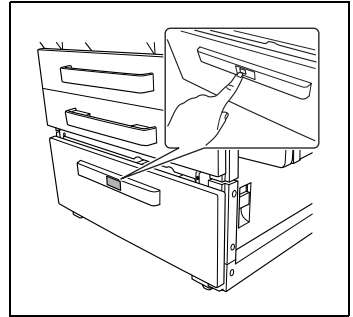

- 2 Load the paper into the right side of the drawer so that the front side of the paper (the side facing up when the package was unwrapped) faces up.



Note

Be careful not to touch the mylar.

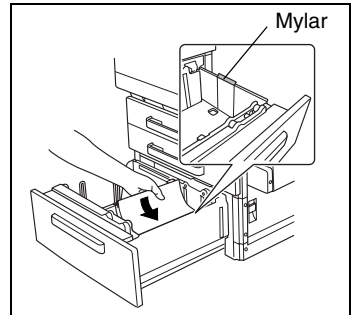

- 3 Load the paper into the left side of the drawer so that the front side of the paper (the side facing up when the package was unwrapped) faces up.

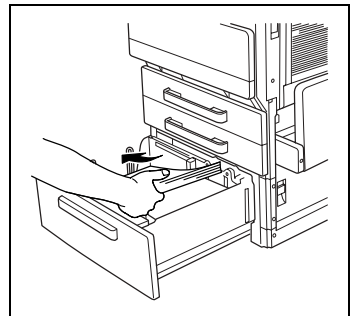

Loading Paper Into the Multiple Bypass Tray

Use the multiple bypass tray when printing on plain paper, postcards, envelopes, overhead projector transparencies and label sheets.

Copying onto the lower side of the set paper.



Note

To set paper other than plain paper, settings must be made in the panel.

While a copy job is being printed or queued, the paper size for the multiple bypass tray cannot be set.

In addition, the "OHP Interleaving" function cannot be set at the same time.

To load plain paper

- 1 Open the multiple bypass tray.

When loading large-sized paper, open the tray extension.

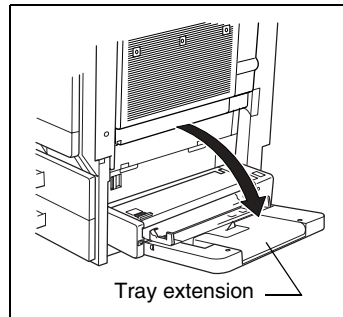

- 2 Adjust the paper guides to fit the size of the paper, and then insert the paper as much as possible into the feed slot.



Note

Do not load so much paper that the top of the stack is higher than the ▼ mark.

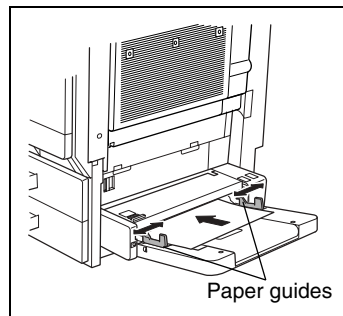

Make sure that the paper guides are pushed up against the edges of the paper.

To load postcards

- When loading postcards, load them with the shorter side as the leading edge, as shown in the illustration, and with the side to be printed on facing down.



...

Note

Do not load more than 50 postcards.

Do not load postcards crosswise.

After you have loaded the paper, set the paper type for the Multiple Bypass Tray in the touch panel.

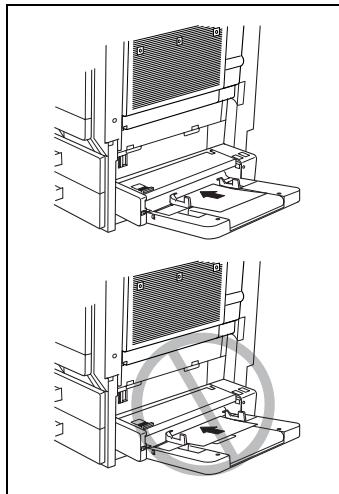

To load envelopes

- When loading envelopes, load them with the flap facing up, as shown in the illustration.



Note

Before loading envelopes, press them down to make sure that all air is removed, and make sure that the folds of the flaps are firmly pressed, otherwise the envelopes may become wrinkled or a paper misfeed may occur.

Do not load more than 10 envelopes.

After you have loaded the paper, set the paper type for the Multiple Bypass Tray in the touch panel.

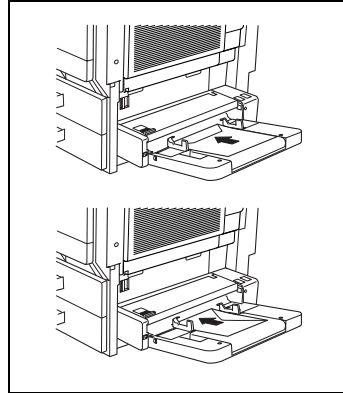

Note

Do not load envelopes crosswise.

Do not place the flap of envelopes facing down.

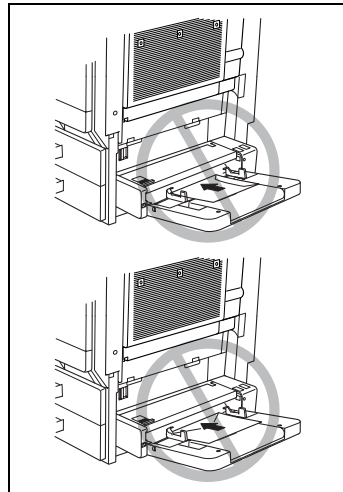

To load overhead projector transparencies

- When loading overhead projector transparencies, load them in the same orientation as the document.



Note

Do not load more than 50 transparencies.

After you have loaded the paper, set the paper type for the Multiple Bypass Tray in the touch panel.

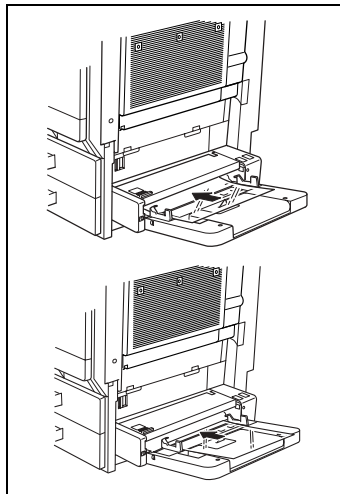

To load label sheets

- 1 When loading label sheets, load them in the same orientation as the document.
- 2 Place documents with the side to be printed facing down.



Note

Do not load more than 50 label sheets.

After you have loaded the paper, set the paper type for the Multiple Bypass Tray in the touch panel.

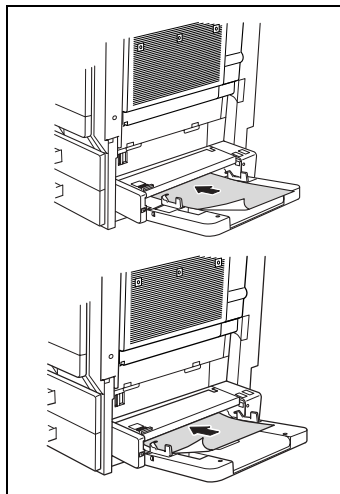

To set a non-standard (custom) paper size

If non-standard-sized paper is loaded, it will be necessary to enter the paper size.

Two non-standard paper sizes can be stored for easy selection. For details, refer to the next section.



Note

Where you do not wish to set the custom size, press the [Panel Reset] key, or exceed the auto panel reset time, and this will reset to the default settings.

- 1 Touch [Paper].
- 2 Touch the button for the multiple bypass tray, and then touch [Mode Change].

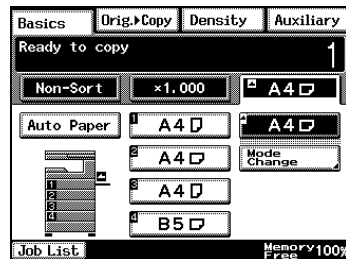

- 3 Touch [Custom Size].
The Custom Size screen appears.

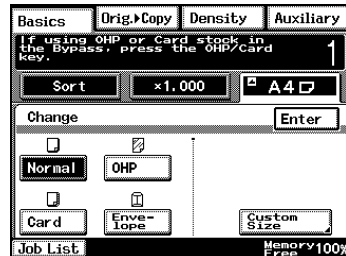

- 4 Touch [X] and press the [C] key.
Then, using the 10-Key Pad, type in the length of side X for the document.

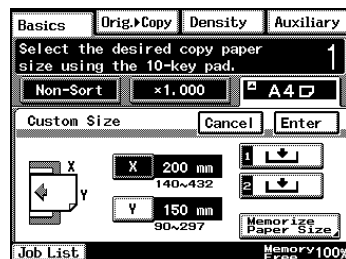

- 5 Touch [Y] and press the [C] key. Then, using the 10-Key Pad, type in the length of side Y for the document.
- 6 Touch [Enter].

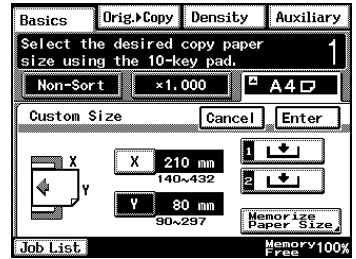

To store a non-standard (custom) paper size

Two non-standard paper sizes can be stored. Storing paper sizes that are used often enables the paper size to be selected quickly.



Note

When you do not wish to set the custom size, press the [Panel Reset] key, or exceed the auto panel reset time, and this will reset to the default settings.

- 1 Touch the button for the multiple bypass tray, and then touch [Mode Change].

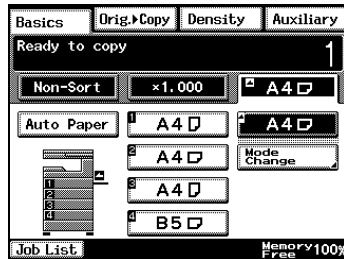

- 2 Touch [Custom Size].
The Custom Size screen appears.

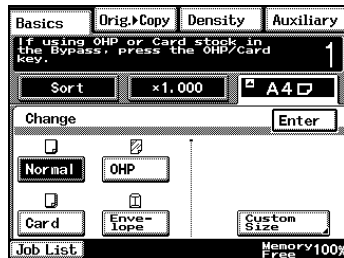

- 3 Touch [Memorize Paper Size].

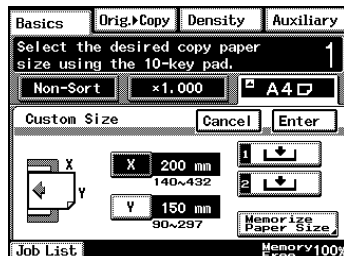

- 4 Touch [X] and press the [C] key. Then, using the 10-Key Pad, type in the length of side X for the document.

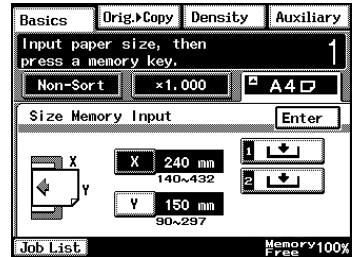

- 5 Touch [Y] and press the [C] key. Then, using the 10-Key Pad, type in the length of side Y for the document.

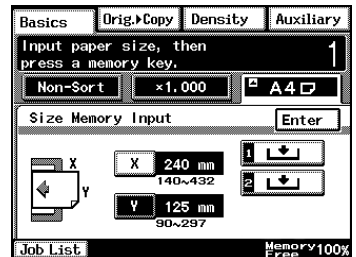

- 6 Touch [1] or [2].
- If a paper size has already been stored at the selected button, the previously assigned paper size is deleted and the new paper size is stored.
 - To store another custom paper size, repeat steps 4,5 and 6.

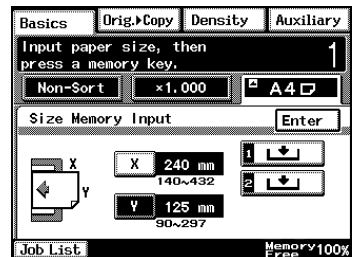

- 7 Touch [Enter].

This completes the storing of custom paper sizes.

To select a stored non-standard (custom) paper size

Copies can be made using the stored custom paper size.

- 1 Position the document(s) to be copied.
- 2 Touch [Paper].
- 3 Touch the button for the multiple bypass tray, and then touch [Mode Change].

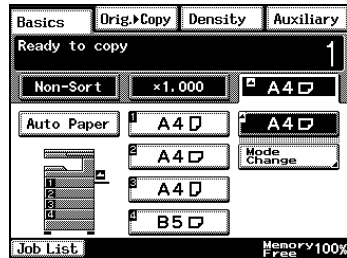

- 4 Touch [Custom Size].

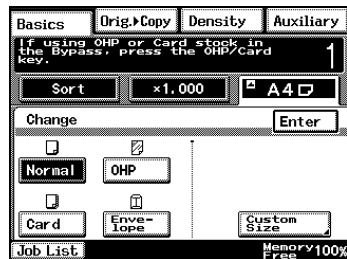

- 5 Touch either [1] or [2] to select the stored custom paper size, and then touch [Enter].

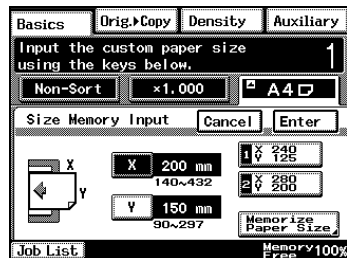

- 6 Press the [Start] key.
The copies are printed.

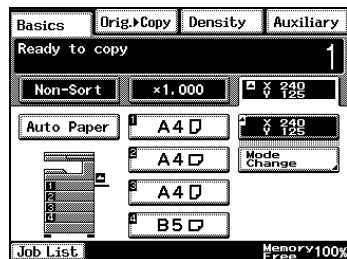

9.7 Selecting the Paper Setting

The paper loaded into a paper drawer or the multiple bypass tray can be selected for making copies.

To select paper loaded into a paper drawer

- 1 Position the document(s) to be copied.
- 2 Touch [Paper].
- 3 Touch the button for the paper drawer loaded with the desired size of paper, and then press the [Start] key.

The copies are printed.

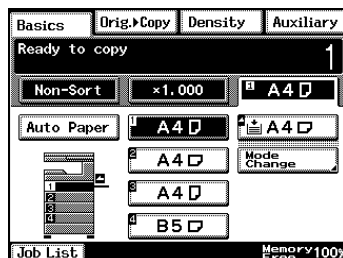

To select paper loaded into the multiple bypass tray

- 1 Position the document(s) to be copied.
- 2 Touch [Paper].
- 3 Touch the button for the multiple bypass tray, and then touch [Mode Change].

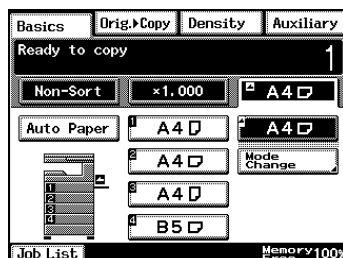

- 4 Touch the button for the type of paper loaded into the multiple bypass tray, and then touch [Enter].
- 5 Press the [Start] key.

The copies are printed.



10 Original Documents



10.1 Feeding the Document

Using the Duplexing Document Feeder

The duplexing document feeder automatically feeds in, scans, then feeds out each page of a multi-page document, one page at a time. The correct type of document must be loaded in order for the duplexing document feeder to function properly.

If the correct type of document is not used, this may cause in a misfeed or damage to the copier.

Document Types

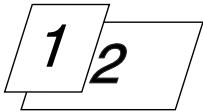
Single-sided documents	Double-sided documents	Documents of mixed sizes
		

Documents of Uniform Sizes

	Single-Sided Documents	Double-Sided Documents
Paper Type	Plain Paper (35 to 128 g/m ²)	Plain Paper (50 to 128 g/m ²)
Document Size	A3 L, B4 L, A4 L/C, B5 L/C, A5 L/C, B6 L	

Documents of Mixed Original Detection mode

	Single-Sided Documents	Double-Sided Documents
Paper Type	Plain Paper (50 to 128 g/m ²)	
Document Size	Refer to "Mixed Width Document Sizes".	

Mixed Width Document Sizes

Maximum Document Width		297 mm		257 mm		210 mm		182 mm	148 mm	123 mm
		A3 L	A4 C	B4 L	B5 C	A4 L	A5 C	B5 L	A5 L	B6 L
Mixed Width Document Detection		A3 L	A4 C	B4 L	B5 C	A4 L	A5 C	B5 L	A5 L	B6 L
297 mm	A3 L	○	○	—	—	—	—	—	—	—
	A4 C	○	○	—	—	—	—	—	—	—
257 mm	B4 L	○	○	○	○	—	—	—	—	—
	B5 C	○	○	○	○	—	—	—	—	—
210 mm	A4 L	○	○	○	○	○	○	—	—	—
	A5 C	—	—	○	○	○	○	—	—	—
182 mm	B5 L	—	—	○	○	○	○	○	—	—
148 mm	A5 L	—	—	—	—	—	—	○	○	—
123 mm	B6 L	—	—	—	—	—	—	—	○	○

○: Copying possible —: Copying not possible

Precautions Concerning the Documents

The following types of documents should not be loaded into the duplexing document feeder, otherwise paper misfeeds or damage to the document may occur. Instead, these types of documents should be positioned on the original glass.

Documents on special paper

- Folded documents (folded in half or fanned)
- Highly translucent or transparent documents, such as diazo photosensitive paper
- Documents with binder holes
- Documents with many binder holes, such as loose-leaf paper
- Coated documents, such as heat-sensitive or carbon-backed paper
- Inkjet printer paper
- Documents that have just been printed with this copier

Documents on paper that cannot be fed

- Curled documents
- Wrinkled or torn documents
- Overhead transparencies

If non-standard-sized paper is determined to be close to a standard size, copying with the “Auto Paper” or “Auto Size” settings is possible.

10.2 Feeding the Document Through the Duplexing Document Feeder

Loading the Document

- 1 Slide the adjustable document guides to fit the size of the document.

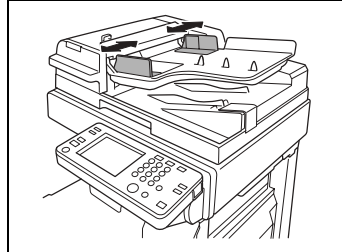

- 2 Load the documents to be faxed or copied face up.



...

Note

A document consisting of up to 80 pages can be loaded. Do not load so many pages that the top of the stack is higher than the mark.

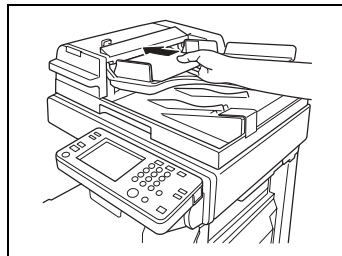

- 3 Adjust the document guides to the size of the document.



...

Note

Be sure to load the document correctly, otherwise the pages may not be fed in straight.

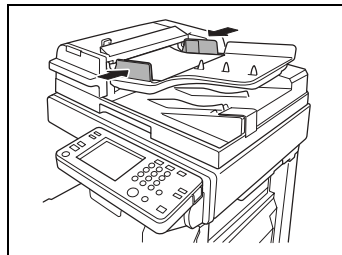

- 4 Touch [Original Direction], and then select the setting appropriate for your document.



Note

If the orientation of the document is different from that of the selected Original Direction setting, certain copy operations, such as 2in1 or 4in1 copying, will not be printed correctly.

- 5 Press the [Start] key.

The pages of the document are fed in, starting with the topmost page.

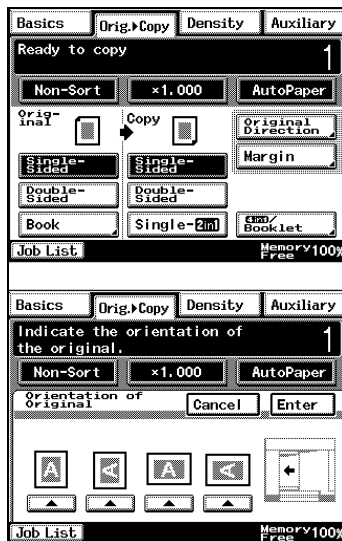

To load a document of mixed sizes (“Mixed Orig Detection” function)

With mixed width document detection, documents of various standard-sized pages can be scanned and copied as a set using the duplexing document feeder.

- 1 Stack the pages of the document face up as shown, making sure that all pages are aligned at the top edge and on the left side.

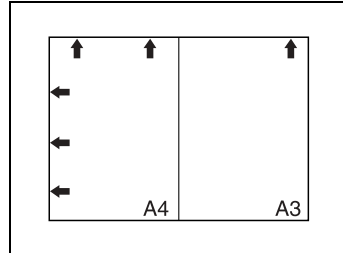

- 2 Slide the adjustable document guides to fit the size of the largest page.

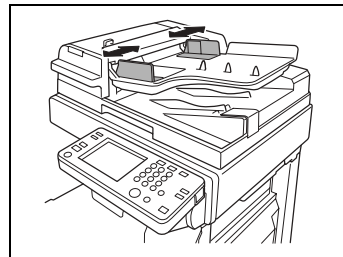

- 3 Load the document so that all pages are aligned along the document guide toward the rear of the copier.

- 4 Adjust the document guides to the size of the document.

- Be sure to load the document correctly, otherwise the pages may not be fed in straight.

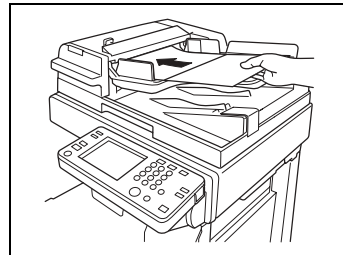

Note

Certain document size combinations are not possible with the “Mixed Orig Detection” function. For details, refer to page 10-2.

- 5 In the Basics screen, touch [Mixed Orig Detection].
- 6 Select the desired copy settings, and then press the [Start] key.

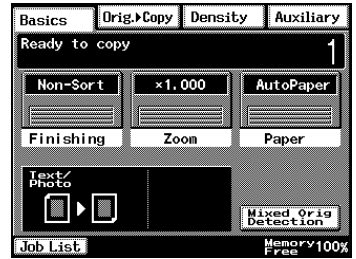

10.3 Positioning Documents on the Original Glass

The procedure for positioning the document differs depending on the type of document being copied, therefore be sure the document is positioned correctly. For information on using the duplexing document feeder, refer to "Feeding the Document Through the Duplexing Document Feeder" (page 10-4).

When placing the document directly on the original glass, position it after lifting the original cover or the duplexing document feeder 15° or more, as shown below.

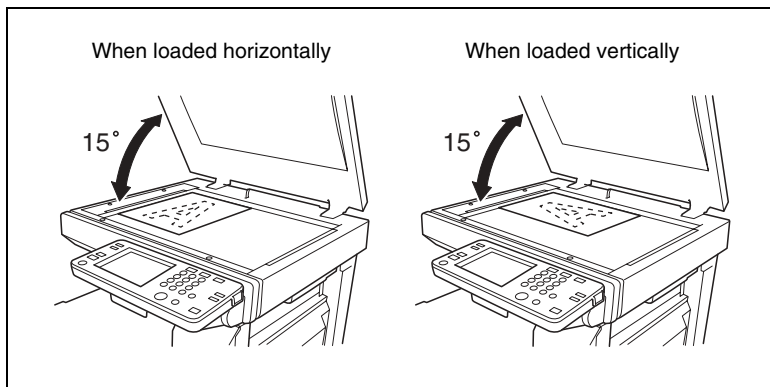

To position sheet documents

Follow the procedure described below when copying plain paper or documents that cannot be fed through the duplexing document feeder.

- 1 Lift open the original cover, or the duplexing document feeder if it is installed, and then position the document face down on the original glass.

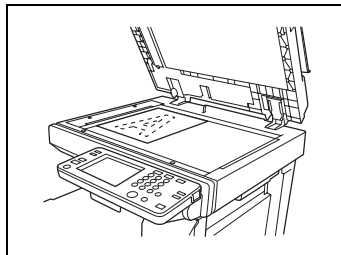

- 2 Position the document so that it aligns with the arrow in the upper-left corner of the document scales.
- 3 Carefully close the original cover, or the duplexing document feeder if it is installed.

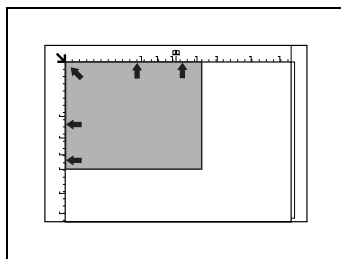

To position transparent or translucent documents

Follow the procedure described below when copying documents, such as overhead transparencies, tracing paper or diazo photosensitive paper.

- 1 Lift open the original cover, or the duplexing document feeder if it is installed, and then position the document face down on the original glass.
- 2 Position the document so that it aligns with the arrow in the upper-left corner of the document scales.
- 3 Place a blank sheet of paper of the same size over the document.
- 4 Carefully close the original cover, or the duplexing document feeder if it is installed.

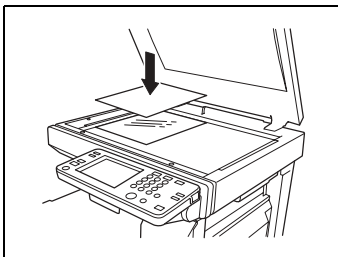
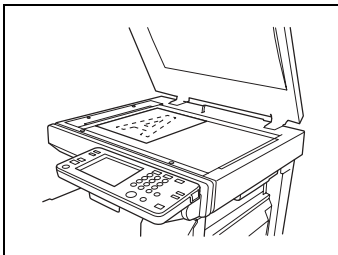

To position books or magazines

Follow the procedure described below when copying bound documents, such as books and magazines.

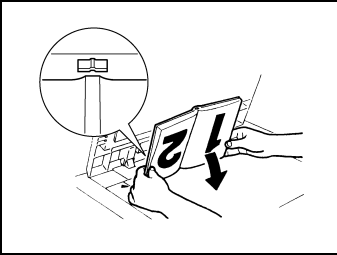
- 1 In the Basics screen, touch [Orig. > Copy], and touch [Book]. Then, make other settings.
- 2 Lift open the original cover, or the duplexing document feeder if it is installed.
- 3 Position the document face down on the original glass, with the top of the book toward the rear of the copier and with the center of the book aligned with the book mark in the document scale.
- 4 Carefully close the original cover, or the duplexing document feeder if it is installed.



Note

For thick documents, make the copy without closing the original cover or duplexing document feeder.

While the document is being scanned with the original cover or duplexing document feeder open, do not look directly at the bright light that may shine through the original glass.

If the document is not positioned correctly, the copies will not be printed in the correct sequence.

Lift open the original cover, or the duplexing document feeder if it is installed, 15° or more.

Do not place objects exceeding 3 kg on the original glass.

If a book is placed on the original glass, do not press it down with extreme force, otherwise the original glass may be damaged.



Tip

For details, refer to "Copying a Book" on page 11-25.

10.4 Loading Documents for Specific Applications

The most appropriate document feed method and copy settings for specific applications are described below.

For details on specifying the various copy settings, refer to “11 Specifying Copy Settings”.

Description of the Table

1. Single-Sided Document ► Single-Sided Copy					
Desired Copy	4. Copy Setting	5. Finishing Setting	6. Margin Setting (Orig. ► Copy Screen)	7. File Margin Setting (Auxiliary Screen)	8. Binding Position

3.



2.		Single-Sided	Corner Staple	—	—	—
----	--	--------------	---------------	---	---	---

* A dash (—) indicates that no setting should be selected.

- Shows whether the original document and the desired copy are single-sided or double-sided.
- Shows how the copy will appear.
- Shows how the document should be positioned. (page 10-4)
- Shows the selected Copy setting. (Single-Sided, Double-Sided, 2in1 or 4in1) on the Orig. ► Copy screen. (page 11-18)
- Shows the selected Finishing setting. (Corner Staple, 2-Point Staple or Hole Punch) (page 11-1)
- Shows the selected Margin setting from the Orig. ► Copy screen if a margin is specified for the document. (page 11-23)
- Shows the selected File Margin setting from the Auxiliary screen if a binding margin is specified for the copy. (Advanced Operations volume)
- Shows the stapling or hole-punching position that must be selected. (page 11-6 and page 11-8)

Single-Sided Documents

Single-Sided Document ▶ Single-Sided Copy					
Desired Copy	Copy Setting	Finishing Setting	Margin Setting (Orig. ▶ Copy Screen)	File Margin Setting (Auxiliary Screen)	Binding Position



Document: Horizontal Paper

	Single-Sided	Corner Staple	—	—	—
	Single-Sided	Corner Staple	—	—	—
	Single-Sided	Hole Punch 2-Point Staple	—	—	—
	Single-Sided	Hole Punch 2-Point Staple	—	—	



Document: Vertical Paper

	Single-Sided	Corner Staple	—	—	—
	Single-Sided	Corner Staple	—	—	—
	Single-Sided	Hole Punch 2-Point Staple	—	—	
	Single-Sided	Hole Punch 2-Point Staple	—	—	—

Single-Sided Document ▶ Single-Sided Copy					
Desired Copy	Copy Setting	Finishing Setting	Margin Setting (Orig. ▶ Copy Screen)	File Margin Setting (Auxiliary Screen)	Binding Position



Document: Horizontal Paper

	Single-2in1	Corner Staple	—	—	—
	Single-2in1	Corner Staple	—	—	—
	Single-2in1	Hole Punch 2-Point Staple	—	—	
	Single-2in1	Hole Punch 2-Point Staple	—	—	—

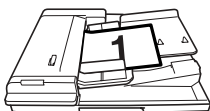

Document: Vertical Paper

	Single-2in1	Corner Staple	—	—	—
	Single-2in1	Corner Staple	—	—	—
	Single-2in1	Hole Punch 2-Point Staple	—	—	—
	Single-2in1	Hole Punch 2-Point Staple	—	—	

Single-Sided Document ▶ Single-Sided Copy					
Desired Copy	Copy Setting	Finishing Setting	Margin Setting (Orig. ▶ Copy Screen)	File Margin Setting (Auxiliary Screen)	Binding Position



Document: Horizontal Paper

	Single-4in1	Corner Staple	—	—	—
	Single-4in1	Corner Staple	—	—	—
	Single-4in1	Hole Punch 2-Point Staple	—	—	—
	Single-4in1	Hole Punch 2-Point Staple	—	—	







Document: Vertical Paper

	Single-4in1	Corner Staple	—	—	—
	Single-4in1	Corner Staple	—	—	—
	Single-4in1	Hole Punch 2-Point Staple	—	—	
	Single-4in1	Hole Punch 2-Point Staple	—	—	—

Single-Sided Document ► Double-Sided Copy					
Desired Copy	Copy Setting	Finishing Setting	Margin Setting (Orig. ► Copy Screen)	File Margin Setting (Auxiliary Screen)	Binding Position

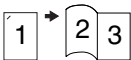
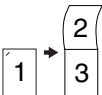

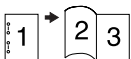
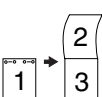



Document: Horizontal Paper

	Double-Sided	Corner Staple	—	—	—
	Double-Sided	Corner Staple	—		—
	Double-Sided	Hole Punch 2-Point Staple	—	—	—
	Double-Sided	Hole Punch 2-Point Staple	—	—	

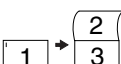
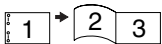

Document: Vertical Paper

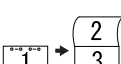
	Double-Sided	Corner Staple	—		—
	Double-Sided	Corner Staple	—	—	—
	Double-Sided	Hole Punch 2-Point Staple	—	—	
	Double-Sided	Hole Punch 2-Point Staple	—	—	—

Single-Sided Document ▶ Double-Sided Copy					
Desired Copy	Copy Setting	Finishing Setting	Margin Setting (Orig. ▶ Copy Screen)	File Margin Setting (Auxiliary Screen)	Binding Position



Document: Horizontal Paper

	Double-2in1	Corner Staple	—		—
	Double-2in1	Corner Staple	—	—	—
	Double-2in1	Hole Punch 2-Point Staple	—	—	
	Double-2in1	Hole Punch 2-Point Staple	—	—	—



Document: Vertical Paper

	Double-2in1	Corner Staple	—	—	—
	Double-2in1	Corner Staple	—		—
	Double-2in1	Hole Punch 2-Point Staple	—	—	—
	Double-2in1	Hole Punch 2-Point Staple	—	—	

Single-Sided Document ► Double-Sided Copy					
Desired Copy	Copy Setting	Finishing Setting	Margin Setting (Orig. ► Copy Screen)	File Margin Setting (Auxiliary Screen)	Binding Position



Document: Horizontal Paper

	Double-4in1	Corner Staple	—	—	—
	Double-4in1	Corner Staple	—		—
	Double-4in1	Hole Punch 2-Point Staple	—	—	—
	Double-4in1	Hole Punch 2-Point Staple	—	—	



Document: Vertical Paper

	Double-4in1	Corner Staple	—		—
	Double-4in1	Corner Staple	—	—	—
	Double-4in1	Hole Punch 2-Point Staple	—	—	
	Double-4in1	Hole Punch 2-Point Staple	—	—	—

Left-Bound Double-Sided Documents

Left-Bound Double-Sided Document ► Single-Sided Copy					
Desired Copy	Copy Setting	Finishing Setting	Margin Setting (Orig. ► Copy Screen)	File Margin Setting (Auxiliary Screen)	Binding Position



Document: Horizontal Paper

	Single-Sided	Corner Staple	—	—	—
	Single-Sided	Corner Staple	—	—	—
	Single-Sided	Hole Punch 2-Point Staple	—	—	—
	Single-Sided	Hole Punch 2-Point Staple	—	—	



Document: Vertical Paper

	Single-Sided	Corner Staple		—	—
	Single-Sided	Corner Staple		—	—
	Single-Sided	Hole Punch 2-Point Staple		—	—
	Single-Sided	Hole Punch 2-Point Staple		—	

Left-Bound Double-Sided Document ▶ Single-Sided Copy					
Desired Copy	Copy Setting	Finishing Setting	Margin Setting (Orig. ▶ Copy Screen)	File Margin Setting (Auxiliary Screen)	Binding Position



Document: Horizontal Paper

	Single-2in1	Corner Staple	—	—	—
	Single-2in1	Corner Staple	—	—	—
	Single-2in1	Hole Punch 2-Point Staple	—	—	
	Single-2in1	Hole Punch 2-Point Staple	—	—	—

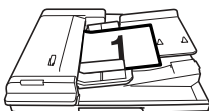

Document: Vertical Paper

	Single-2in1	Corner Staple		—	—
	Single-2in1	Corner Staple		—	—
	Single-2in1	Hole Punch 2-Point Staple		—	—
	Single-2in1	Hole Punch 2-Point Staple		—	

Left-Bound Double-Sided Document ► Single-Sided Copy					
Desired Copy	Copy Setting	Finishing Setting	Margin Setting (Orig. ► Copy Screen)	File Margin Setting (Auxiliary Screen)	Binding Position



Document: Horizontal Paper

	Single-4in1	Corner Staple	—	—	—
	Single-4in1	Corner Staple	—	—	—
	Single-4in1	Hole Punch 2-Point Staple	—	—	—
	Single-4in1	Hole Punch 2-Point Staple	—	—	



Document: Vertical Paper

	Single-4in1	Corner Staple		—	—
	Single-4in1	Corner Staple		—	—
	Single-4in1	Hole Punch 2-Point Staple		—	—
	Single-4in1	Hole Punch 2-Point Staple		—	

Left-Bound Double-Sided Document ▶ Double-Sided Copy					
Desired Copy	Copy Setting	Finishing Setting	Margin Setting (Orig. ▶ Copy Screen)	File Margin Setting (Auxiliary Screen)	Binding Position



Document: Horizontal Paper

	Double-Sided	Corner Staple	—	—	—
	Double-Sided	Corner Staple	—		—
	Double-Sided	Hole Punch 2-Point Staple	—	—	—
	Double-Sided	Hole Punch 2-Point Staple	—	—	



Document: Vertical Paper

	Double-Sided	Corner Staple		—	—
	Double-Sided	Corner Staple			—
	Double-Sided	Hole Punch 2-Point Staple			—
	Double-Sided	Hole Punch 2-Point Staple		—	—

Left-Bound Double-Sided Document ► Double-Sided Copy					
Desired Copy	Copy Setting	Finishing Setting	Margin Setting (Orig. ► Copy Screen)	File Margin Setting (Auxiliary Screen)	Binding Position



Document: Horizontal Paper

	Double-2in1	Corner Staple	—		—
	Double-2in1	Corner Staple	—	—	—
	Double-2in1	Hole Punch 2-Point Staple	—	—	
	Double-2in1	Hole Punch 2-Point Staple	—	—	—



Document: Vertical Paper

	Double-2in1	Corner Staple		—	—
	Double-2in1	Corner Staple			—
	Double-2in1	Hole Punch 2-Point Staple		—	—
	Double-2in1	Hole Punch 2-Point Staple		—	

Left-Bound Double-Sided Document ► Double-Sided Copy					
Desired Copy	Copy Setting	Finishing Setting	Margin Setting (Orig. ► Copy Screen)	File Margin Setting (Auxiliary Screen)	Binding Position



Document: Horizontal Paper

	Double-4in1	Corner Staple	—	—	—
	Double-4in1	Corner Staple	—		—
	Double-4in1	Hole Punch 2-Point Staple	—	—	—
	Double-4in1	Hole Punch 2-Point Staple	—	—	

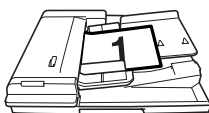

Document: Vertical Paper

	Double-4in1	Corner Staple		—	—
	Double-4in1	Corner Staple			—
	Double-4in1	Hole Punch 2-Point Staple		—	
	Double-4in1	Hole Punch 2-Point Staple		—	—

Top-Bound Double-Sided Documents

Top-Bound Double-Sided Document ► Single-Sided Copy					
Desired Copy	Copy Setting	Finishing Setting	Margin Setting (Orig. ► Copy Screen)	File Margin Setting (Auxiliary Screen)	Binding Position



Document: Horizontal Paper

	Single-Sided	Corner Staple		—	—
	Single-Sided	Corner Staple		—	—
	Single-Sided	Hole Punch 2-Point Staple		—	
	Single-Sided	Hole Punch 2-Point Staple		—	—



Document: Vertical Paper

	Single-Sided	Corner Staple	—	—	—
	Single-Sided	Corner Staple	—	—	—
	Single-Sided	Hole Punch 2-Point Staple	—	—	
	Single-Sided	Hole Punch 2-Point Staple	—	—	—

Top-Bound Double-Sided Document ▶ Single-Sided Copy					
Desired Copy	Copy Setting	Finishing Setting	Margin Setting (Orig. ▶ Copy Screen)	File Margin Setting (Auxiliary Screen)	Binding Position



Document: Horizontal Paper

	Single-2in1	Corner Staple			—
	Single-2in1	Corner Staple		—	—
	Single-2in1	Hole Punch 2-Point Staple		—	
	Single-2in1	Hole Punch 2-Point Staple		—	—

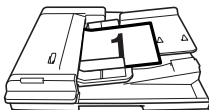

Document: Vertical Paper

	Single-2in1	Corner Staple	—	—	—
	Single-2in1	Corner Staple	—		—
	Single-2in1	Hole Punch 2-Point Staple	—	—	—
	Single-2in1	Hole Punch 2-Point Staple	—	—	

Top-Bound Double-Sided Document ► Single-Sided Copy					
Desired Copy	Copy Setting	Finishing Setting	Margin Setting (Orig. ► Copy Screen)	File Margin Setting (Auxiliary Screen)	Binding Position



Document: Horizontal Paper

	Single-4in1	Corner Staple		—	—
	Single-4in1	Corner Staple		—	—
	Single-4in1	Hole Punch 2-Point Staple		—	
	Single-4in1	Hole Punch 2-Point Staple		—	—



Document: Vertical Paper

	Single-4in1	Corner Staple	—	—	—
	Single-4in1	Corner Staple	—	—	—
	Single-4in1	Hole Punch 2-Point Staple	—	—	
	Single-4in1	Hole Punch 2-Point Staple	—	—	—

Top-Bound Double-Sided Document ▶ Double-Sided Copy					
Desired Copy	Copy Setting	Finishing Setting	Margin Setting (Orig. ▶ Copy Screen)	File Margin Setting (Auxiliary Screen)	Binding Position



Document: Horizontal Paper

	Double-Sided	Corner Staple		—	—
	Double-Sided	Corner Staple			—
	Double-Sided	Hole Punch 2-Point Staple		—	
	Double-Sided	Hole Punch 2-Point Staple		—	—



Document: Vertical Paper

	Double-Sided	Corner Staple	—		—
	Double-Sided	Corner Staple	—	—	—
	Double-Sided	Hole Punch 2-Point Staple	—		—
	Double-Sided	Hole Punch 2-Point Staple	—	—	—

Top-Bound Double-Sided Document ► Double-Sided Copy					
Desired Copy	Copy Setting	Finishing Setting	Margin Setting (Orig. ► Copy Screen)	File Margin Setting (Auxiliary Screen)	Binding Position



Document: Horizontal Paper

	Double-2in1	Corner Staple			—
	Double-2in1	Corner Staple		—	—
	Double-2in1	Hole Punch 2-Point Staple		—	
	Double-2in1	Hole Punch 2-Point Staple		—	—



Document: Vertical Paper

	Double-2in1	Corner Staple	—	—	—
	Double-2in1	Corner Staple	—		—
	Double-2in1	Hole Punch 2-Point Staple	—	—	—
	Double-2in1	Hole Punch 2-Point Staple	—	—	

Top-Bound Double-Sided Document ▶ Double-Sided Copy					
Desired Copy	Copy Setting	Finishing Setting	Margin Setting (Orig. ▶ Copy Screen)	File Margin Setting (Auxiliary Screen)	Binding Position



Document: Horizontal Paper

	Double-4in1	Corner Staple			—
	Double-4in1	Corner Staple		—	—
	Double-4in1	Hole Punch 2-Point Staple		—	
	Double-4in1	Hole Punch 2-Point Staple		—	—



Document: Vertical Paper

	Double-4in1	Corner Staple	—		—
	Double-4in1	Corner Staple	—	—	—
	Double-4in1	Hole Punch 2-Point Staple	—	—	
	Double-4in1	Hole Punch 2-Point Staple	—	—	—

10.5 Large Documents

Precautions for A3 L/B4 L Copies

When making A3 L or B4 L copies, observe the following precautions concerning the orientation of the document and the positions of 2-point stapling or hole-punching.

If any of the following types of documents are loaded, select the  Original Direction setting from the Orig. ► Copy screen. ⇨ page 11-21

When making A3 L or B4 L copies, the “2-Point Staple” and “Hole Punch” settings are not available with the following positions.

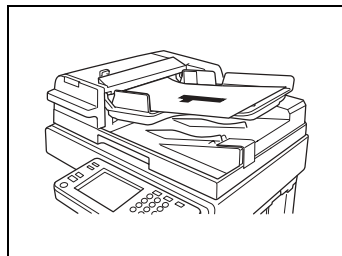

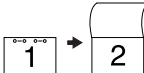
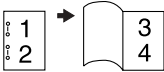
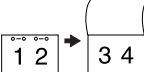
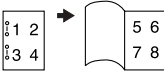
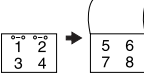
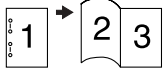
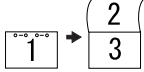
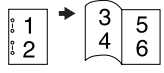
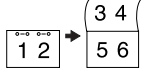
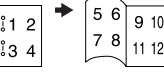
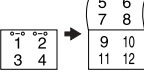

11 Specifying Copy Settings

11.1 Specifying Finishing Settings

Various finishing settings for sorting or grouping, stapling or punching holes in copies are available.

In the touch panel, touch [Basics], and then touch [Finishing]. A screen appears, showing the available Finishing settings.

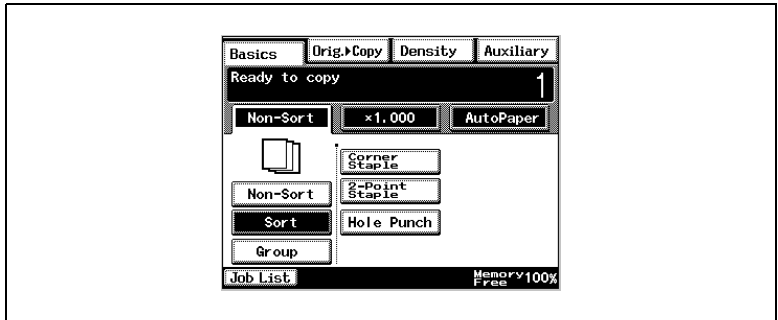

Available Finishing Settings

- Non-Sort
The copies are fed out and stacked on top of each other as they are printed.
- Sort
The copies are automatically divided into the specified number of sets with each set containing a copy of each page.

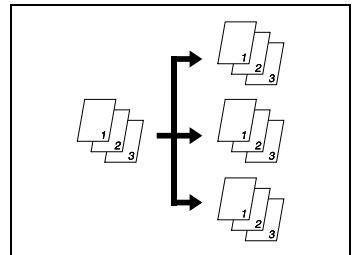
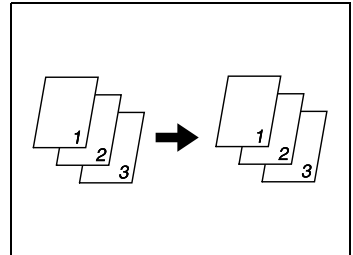

- **Group**
The copies are automatically divided into stacks containing copies of the same page.

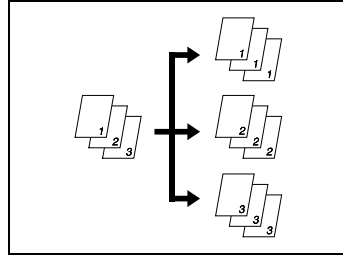

Only when the finisher is installed

- **Corner Staple**
Copies printed with the “Sort” or “Group” setting are automatically stapled together in the upper-left corner.



Note

Thick paper, envelopes and overhead projector transparencies cannot be stapled.

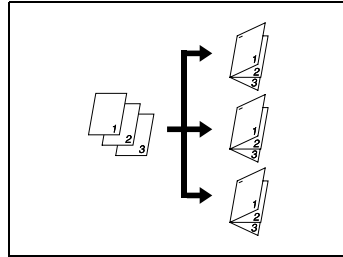

Only when the finisher is installed

- **2-Point Staple**
Copies printed with the “Sort” or “Group” setting are automatically stapled together at two points on the left edge.



Note

Thick paper, envelopes and overhead projector transparencies cannot be stapled.

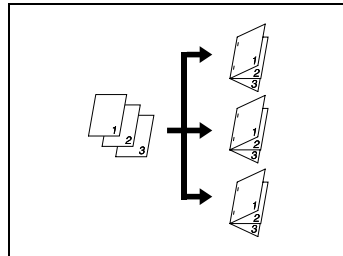

Only when the finisher is installed

- **Hole Punch**

Holes are punched in the copies so they can be filed.

This setting can be combined with the “Non-Sort”, “Sort”, “Group” or a staple setting.



Note

Holes cannot be punched in envelopes and overhead projector transparencies.

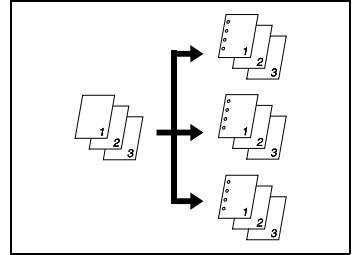

Only when the finisher and the saddle kit are installed

- **Creased and 2-Point Staple**

Automatically crease paper copied in booklet-printing mode, and stapled together at two points in the center.



Note

Thick paper, envelopes and overhead projector transparencies cannot be creased and 2-point stapled.

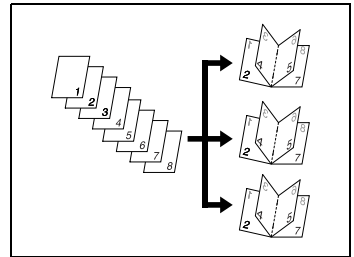

Tip

As a default, “Non-Sort” or “Sort” are automatically selected depending on the number of pages in the document. The default setting is “Non-Sort”. The default setting can be changed using a function on the User’s Choice screen. For details, refer to “Changing Default Settings” on page 7-6.

Notes on Using the “Sort” and “Group” Settings

- If a document positioned on the original glass is copied using the “Sort” setting, copying is automatically performed using the “Separate Scan” function.
For details, refer to “Auxiliary Functions” on page 6-1.
- If the finisher or the mail bin kit is installed, each set of copies is fed out shifted to alternating sides.
- If the job tray is installed, but the finisher or the mail bin kit is not, each set of copies is fed out in an alternating crisscross pattern.

Conditions for crisscross sorting

- Paper of the same type must be loaded horizontally in one paper drawer and vertically in another drawer.
- The “Mixed Orig Detection” function must not be selected.
- None of the following can be selected: a stapling or the “Hole Punch” setting and the “Page Insertion”, the “Cover Mode” and the “Image Repeat” functions.
- A paper drawer cannot be selected.
- A4 or B5 sized paper is set horizontally or vertically.
- If a finisher is installed, crisscross sorting can not be carried out.

Shift Sorting

Each copy set is fed out shifted to alternating sides.

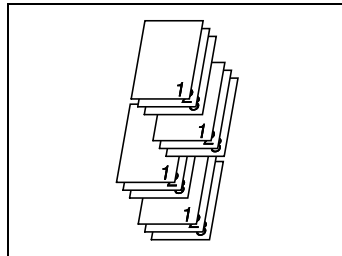

Crisscross Sorting

Each copy set is fed out in an alternating crisscross pattern.

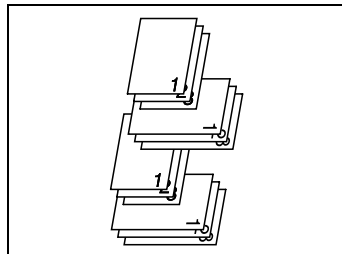

Shift Grouping

Each page set is fed out shifted to alternating sides.

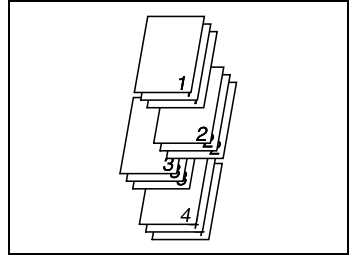
**Crisscross Grouping**

Each page set is fed out in an alternating crisscross pattern.

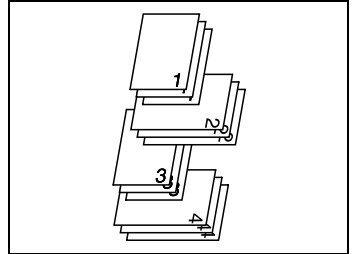

To make copies using a stapling setting

- 1 Position the document(s) to be copied.
 - For details, refer to “10 Original Documents”.
- 2 Touch [Sort], and after selecting your desired sorting mode, touch staple mode.
 - If “Corner Staple” was selected, skip to step 6.
 - If “2-Point Staple” was selected, continue with step 3.
- 3 Touch [Select Position].

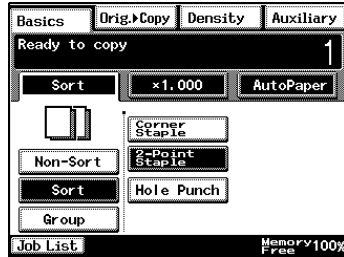

- 4 Touch the button for the desired stapling position.
- 5 Touch [Enter].
- 6 Press the [Start] key.
The copies are printed.

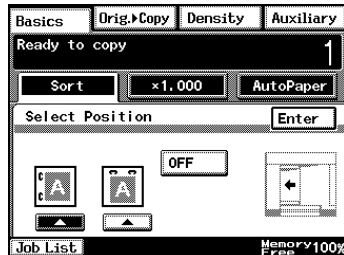
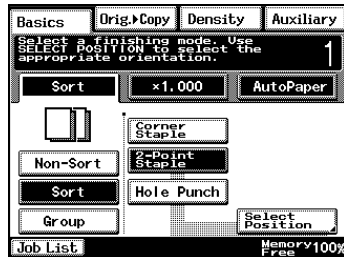

Note

A stapling setting cannot be selected if another job has been interrupted.

When making copies while using a staple setting, be careful of the selected stapling position.

For details, refer to page 11-10.

If “Corner Staple” was selected, the stapling position cannot be specified. However, if the “Corner Staple” setting is used together with the “Hole Punch” setting, the stapling position can be specified.

If a document positioned on the original glass is copied using a stapling setting, copying is automatically performed using the “Separate Scan” function.

For details, refer to “Auxiliary Functions” on page 6-1.

When copying while using a stapling setting, be sure that the maximum number of pages that can be stapled together is not exceeded.

Where you do not set the position, the stapling position is automatically specified.

To make copies using the “Hole Punch” setting

- 1 Position the document(s) to be copied.
 - For details, refer to “10 Original Documents”.
 - 2 Select “Non-Sort”, “Sort” or “Group”, and then touch [Hole Punch].
 - 3 Touch [Select Position].
 - 4 Touch the button for the desired hole punch positions.
 - To allow the hole punch position to automatically be specified, touch [OFF].
 - 5 Touch [Enter].
 - 6 Press the [Start] key.
- The copies are printed.

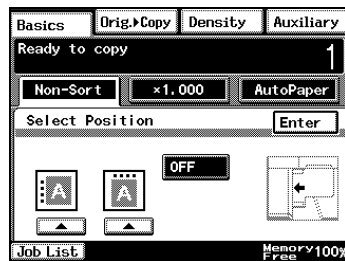
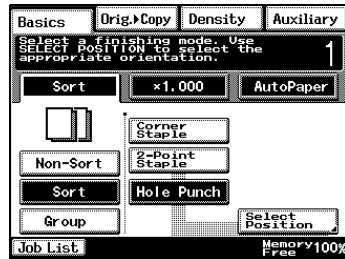

Tip

If copying is started without the hole punch position specified or if "OFF" was selected, the hole punch position is automatically specified according to the document orientation, as shown below.

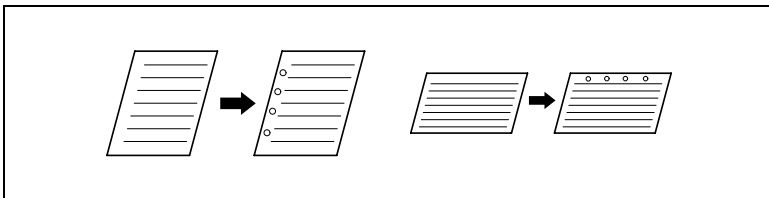

To adjust the position of the punched holes, contact your service representative.

Creasing and Folding

When the optional finisher or saddle kits are installed, you can set a crease to fold paper in two. Additionally, you can add two staples in the middle of the paper (center stapling).

Before selecting the “Crease” setting, be sure to select the “Booklet Creation” setting from the Orig. ► Copy screen. (Refer to page 11-21.)

1 Position the document(s) to be copied.

2 Select “Non-Sort”, “Sort” or “Group”, and then touch [Crease].

- When using Center staple, (folding), select the [2-Point Staple] key.

3 Press the [Start] key.

The copies are printed.

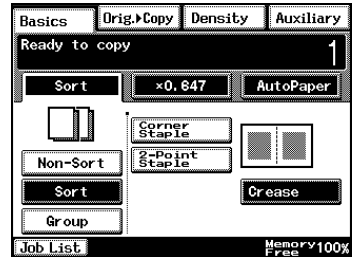

Note

Creased and 2-point staple can be applied to A3, B4, A4, and B5 sized paper.

2 to 15 sheets of paper can be stabled.

Only plain and recycled paper can be creased or 2-Point Stapled.

Notes on the Staple Position













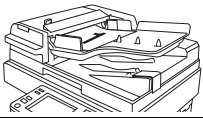
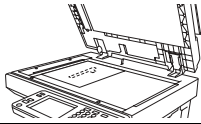



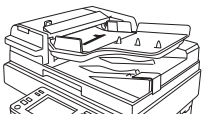
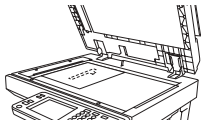

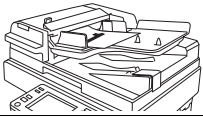
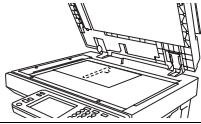

The location that can be stapled differs depending on the paper size and the paper orientation.

Refer to the following table when selecting the paper for copying.

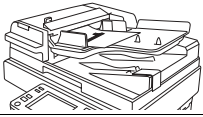
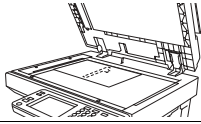
When the “Corner Staple” setting is selected

When the finisher (FN-117) is installed			
Screen Icon	Document Orientation		Staple Position
	Feeding From the Duplexing Document Feeder	Scanning From the Original Glass	
	Document size: A4 C	Document size: A4 C	Paper size: A4 C
	Document size: A4 C	Document size: A4 C	Paper size: A4 C
	Document size: A4 L	Document size: A4 L	Paper size: A4 C
	Document size: A4 L	Document size: A4 L	Paper size: A4 L
	Document size: A3 L, B4 L	Document size: A3 L, B4 L	Paper size: A3 L, B4 L

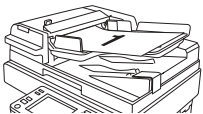
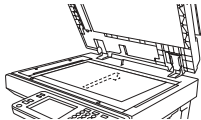
When the “2-Point Staple” setting is selected

When the finisher (FN-117) is installed			
Screen Icon	Document Orientation		Staple Position
	Feeding From the Duplexing Document Feeder	Scanning From the Original Glass	
	Document size: A4 C	Document size: A4 C	Paper size: A4 C
			
	Document size: A4 C	Document size: A4 C	Paper size: A4 L
			
	Document size: A4 L	Document size: A4 L	Paper size: A4 C
			
	Document size: A4 L	Document size: A4 L	Paper size: A4 L
			
	Document size: A3 L, B4 L	Document size: A3 L, B4 L	Paper size: A3 L, B4 L
			









Notes on the Number of Possible Stapled Sets

While copying with a stapling setting, pages may become misaligned or fall. We recommend that no more than the number of sets listed below be stapled.

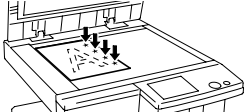
Maximum number of sets	
Number of bound pages	Finisher (A3 L to B6 C)
2 sheets	100 sets
3 to 5 sheets	80 sets
6 to 10 sheets	60 sets
11 to 20 sheets	40 sets
21 to 30 sheets	33 sets
31 to 40 sheets	25 sets
41 to 50 sheets	20 sets

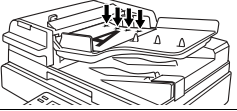
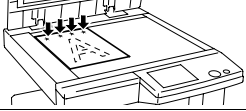
Notes on the Hole Punch Position

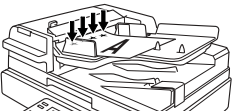
When copying with the "Hole Punch" setting selected, be careful of the orientation of the document.

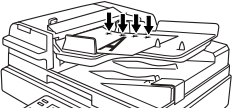
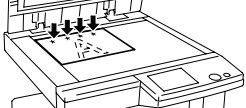
When the finisher (FN-117) and saddle kit are installed		
Screen Icon	Document Orientation	
	Feeding From the Duplexing Document Feeder	Scanning From the Original Glass
		
		
		
		

11.2 Specifying a Zoom Setting

Copies of documents can be enlarged or reduced.

In the touch panel, touch [Basics], and then touch [Zoom]. A screen appears, showing the available Zoom settings.

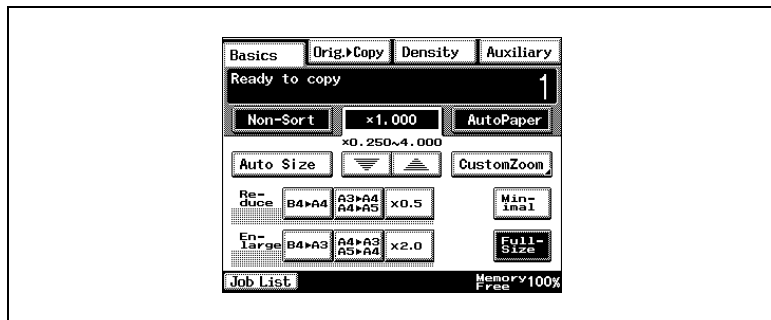

There are eight ways to change the zoom ratio.

- **Auto Size**
The most appropriate zoom ratio based on the size of the document loaded and the specified paper size is automatically selected.
- **Full-Size**
A copy that is the same size as the document ($\times 1.000$) is selected.
- **Enlarge**
Various zoom settings for making enlarged copies from common standard document sizes to standard paper sizes are available.
For example:
 - An A4-size document can be copied onto the larger A3-size paper.
 - A B4-size document can be copied onto the larger A3-size paper.
- **Reduce**
Various zoom settings for making reduced copies from common standard document sizes to standard paper sizes are available.
For example:
 - An A3-size document can be copied onto the smaller A4-size paper.
 - A B4-size document can be copied onto the smaller A4-size paper.
- **Minimal**
The copy is slightly reduced ($\times 0.930$).
 - Selecting the “Minimal” setting ensures that any part of the original positioned at the edge of the page will not be cut off in the copy.
 - The zoom ratio of the “Minimal” setting can be changed to any ratio between $\times 0.900$ and $\times 0.999$.
- **Zooming**
Any zoom ratio (between $\times 0.250$ and $\times 4.000$) can be specified.

- Touch the arrow keys to select the desired zoom ratio. Each time an arrow key is touched, the zoom ratio is increased or decreased by an increment of 0.001.
- CustomZoom
Any zoom ratio (between $\times 0.250$ and $\times 4.000$) can be specified.
- Use the 10-Key Pad to enter the desired zoom ratio.
- Up to two zoom ratios entered using the 10-Key Pad can be stored.
- X/Y Zoom
The copy size can be changed by specifying different scaling proportions (between $\times 0.250$ and $\times 4.000$) for the vertical and the horizontal dimensions.

To select a Zoom setting

- 1 Touch [Zoom].
A screen appears, showing the available Zoom settings.
- 2 Select the desired Zoom setting.

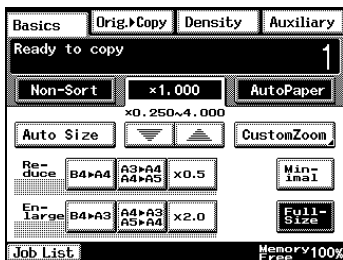

Specifying a “Custom Zoom” Setting

To enter a custom zoom ratio

- 1 Touch [Zoom].

A screen appears, showing the available Zoom settings.

- 2 Touch [CustomZoom].

- 3 Use the 10-Key Pad to type in the desired zoom ratio (between $\times 0.250$ and $\times 4.000$).

- 4 Touch [Enter].

The entered zoom ratio is displayed and is specified as the custom Zoom setting.



To store Custom Zoom and Minimal zoom ratios

- 1 Touch [Zoom].

A screen appears, showing the available Zoom settings.

- 2 Touch [CustomZoom].

- 3 Touch [Memorize Zoom].



- 4 Use the 10-Key Pad to type in the desired zoom ratio (between $\times 0.250$ and $\times 4.000$).

- To store a Minimal zoom ratio, type in the desired zoom ratio between $\times 0.900$ and $\times 0.999$. The entered zoom ratio is displayed.

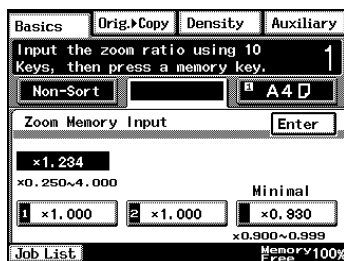

- 5 Touch [1], [2] or [Minimal].

- 6 Touch [Enter].

The entered zoom ratio is stored.

To recall a stored custom zoom ratio

- 1 Touch [Zoom].

A screen appears, showing the available Zoom settings.

- 2 Touch [CustomZoom].

- 3 Touch [1], [2] or [Minimal].

- 4 Touch [Enter].

The entered zoom ratio is recalled.

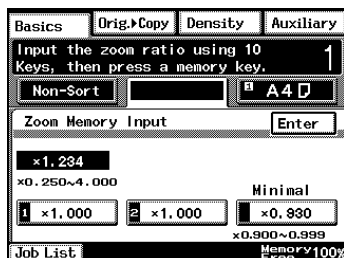

To specify different vertical and horizontal scaling proportions (“X/Y Zoom” setting)

- 1 Touch [Zoom].

A screen appears, showing the available Zoom settings.

- 2 Touch [CustomZoom].

- 3 Touch [X/Y Zoom].

The X/Y Zoom screen appears.

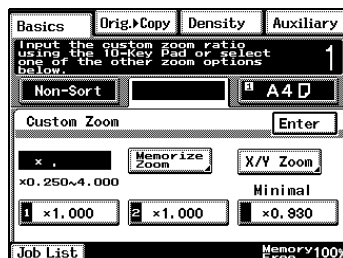

- 4 Use the 10-Key Pad to type in the desired length of side X (between $\times 0.250$ and $\times 4.000$).

- 5 Use the 10-Key Pad to type in the desired length of side Y (between $\times 0.250$ and $\times 4.000$).

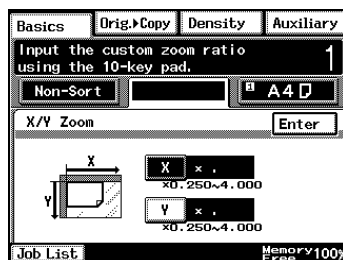

- 6 Touch [Enter].

The entered zoom ratio is applied.

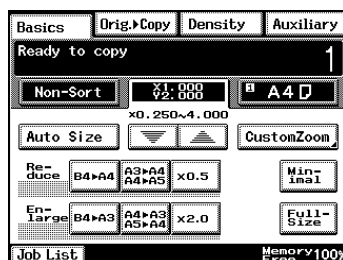

11.3 Selecting the Orig. > Copy Settings

In the touch panel, touch [Orig. > Copy]. A screen appears, showing the available document and copy settings.

Orig. > Copy Settings

- **Single-Sided ► Single-Sided**
A single-sided copy is produced from a single-sided document.
- **Single-Sided ► Double-Sided**
A double-sided copy is produced from two single-sided documents.
- **Single-Sided ► Single-2in1**
A single-sided copy is produced from two single-sided documents.
- **Single-Sided ► Double-2in1**
A double-sided copy is produced from four single-sided documents.
- **Double-Sided ► Single-Sided**
Only if the duplexing document feeder is installed:
Two single-sided copies are produced from a double-sided document.
- **Double-Sided ► Double-Sided**
Only if the duplexing document feeder is installed:
A double-sided copy is produced from a double-sided document.

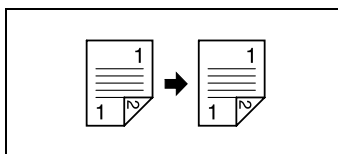
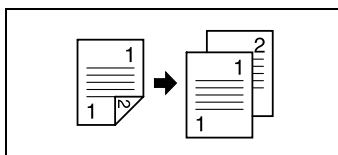
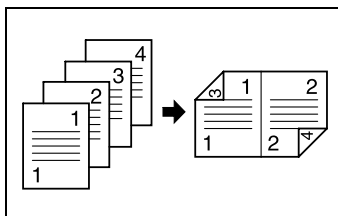
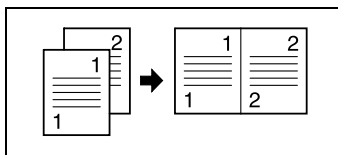
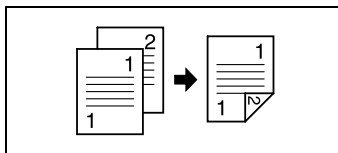
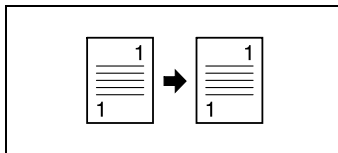

- **Double-Sided ► Single-2in1**
Only if the duplexing document feeder is installed:
A single-sided copy is produced from a double-sided document.

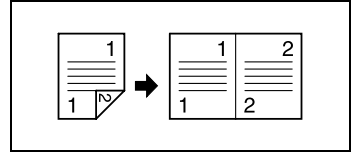

- **Double-Sided ► Double-2in1**
Only if the duplexing document feeder is installed:
A double-sided copy is produced from two double-sided documents.

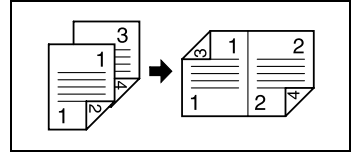

- **Single-Sided ► Single-4in1**
A single-sided copy is produced from four single-sided documents.

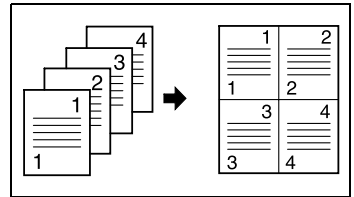

- **Single-Sided ► Double-4in1**
A double-sided copy is produced from eight single-sided documents.

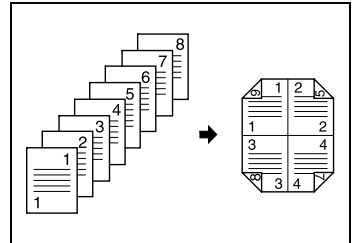

- **Single-Sided ► Booklet Creation**
A double-sided copy is produced from four single-sided documents.

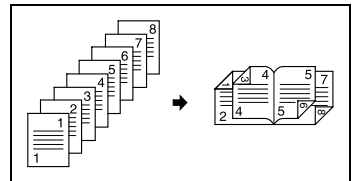

- **Double-Sided ► Single-4in1**
Only if the duplexing document feeder is installed:
A single-sided copy is produced from two double-sided documents.

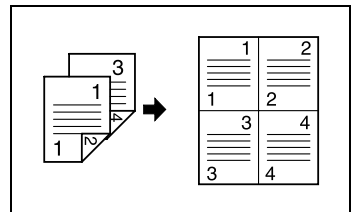

- **Double-Sided ▶ Double-4in1**
Only if the duplexing document feeder is installed:
A double-sided copy is produced from four double-sided documents.

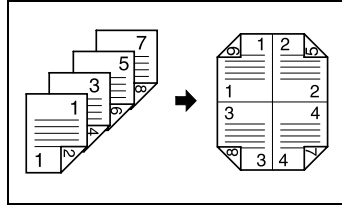

- **Book (Separation) ▶ Single-Sided**
Two single-sided copies are produced from a bound document.

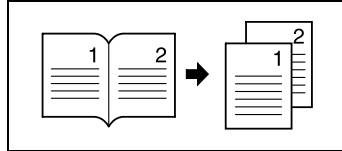

- **Book (Spreadsheet) ▶ Single-Sided**
A single-sided copy is produced from a bound document.

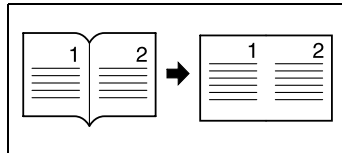

- **Book (Separation) ▶ Double-Sided**
A double-sided copy is produced from a bound document.

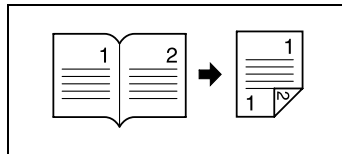

- **Book (Spreadsheet) ▶ Double-Sided**
A double-sided copy is produced from a bound document.

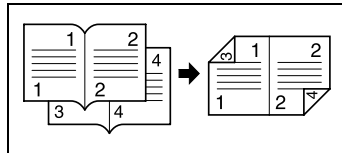

To specify Orig. > Copy settings

- 1 Position the document(s) to be copied.
 - For details, refer to “10 Original Documents”.

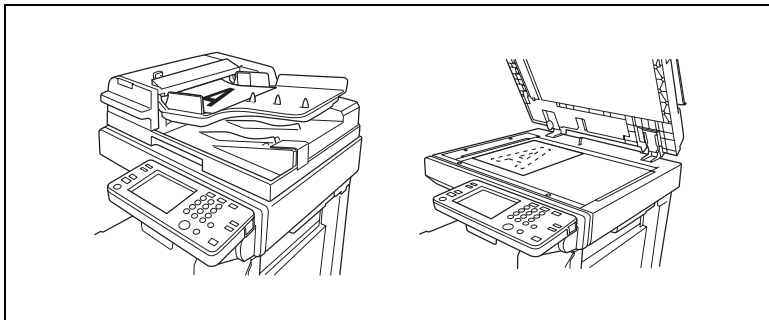

- 2 Touch [Orig. > Copy].
- 3 Select the setting for the type of document to be copied.
(For the example at the right, touch [Single-Sided].)

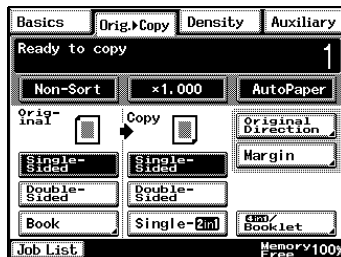

- 4 Select the setting for the desired type of copy.
(For the example at the right, touch [Double-Sided].)

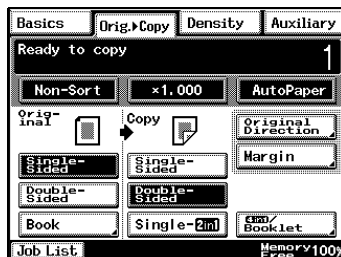

- To select the “Double-2in1”, “Booklet Creation”, “Single-4in1” or “Double-4in1” settings, touch [4in1/Booklet].



- Select the desired type of copy, and touch [Enter].

5 Touch [Original Direction].

- Select an Original Direction setting if the document is loaded in an orientation other than the standard.

6 Select the appropriate document orientation setting.

7 Touch [Enter].

8 Press the [Start] key.

The copies are printed.

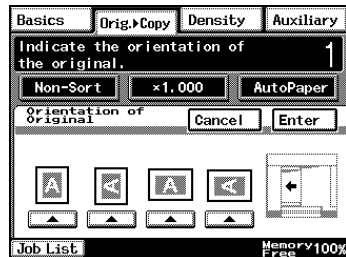

Copying a Bound Document

The scanning position for bound documents can be adjusted.

The binding width can be seen by making copies with the “Single-Sided > Double-Sided” or the “Double-Sided > Single-Sided” settings selected.

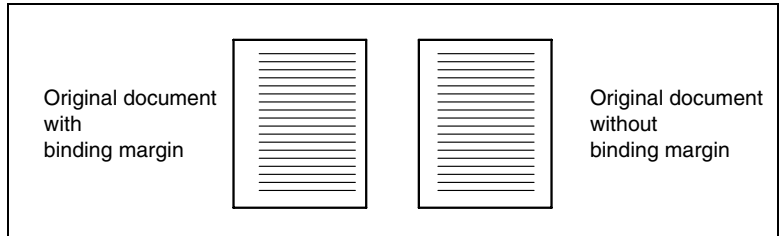

- 1 Position the document(s) to be copied.
 - For details, refer to “10 Original Documents”.
- 2 Touch [Orig. > Copy].
- 3 Touch [Margin].



- 4 Select the appropriate binding margin position.
 - There are two locations for the binding position, as shown in the illustrations at the right.

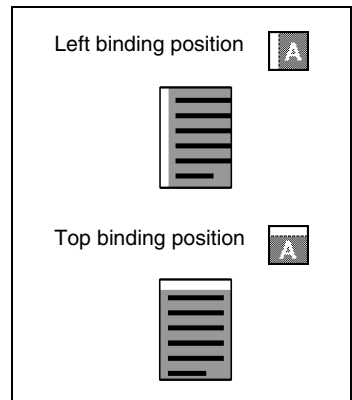

- 5 Touch the big arrow keys to select the desired binding margin width.
 - The binding margin can be set between 0 mm and 20 mm, in 1 mm increments.
- 6 Touch [Enter].
- 7 Press the [Start] key.
The copies are printed.

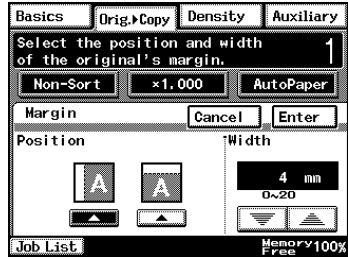

Tip

If the setting for the left binding position is selected for double-sided copying, the front and back sides of the page will be printed with the same orientation.

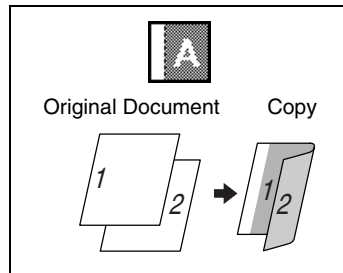

If the setting for the top binding position is selected for double-sided copying, the back side of the page is printed upside down.

To adjust the width of the area erased from the bottom of the back side of the page, contact your service representative.

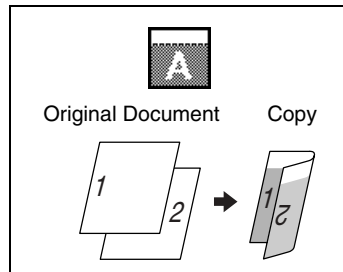

Copying a Book

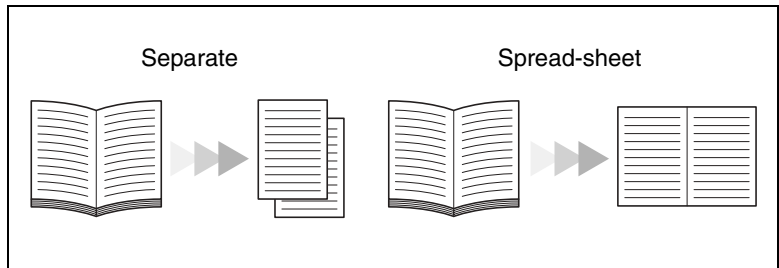

- 1 Position the document(s) to be copied.
 - For details, refer to “10 Original Documents”.
- 2 Touch [Orig. > Copy].
- 3 Touch [Book].



- 4 Select the appropriate setting for the binding position of the book (“Standard Book” or “RightBound”).
- 5 Select whether to copy both pages of the book onto one sheet (“Spreadsheet”) or onto two separate sheets (“Separation”).
- 6 To erase around the text or along the binding, touch [Book Erase].

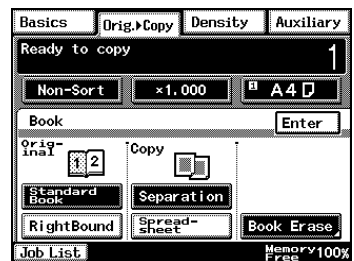

- 7 Select the desired Book Erase setting.

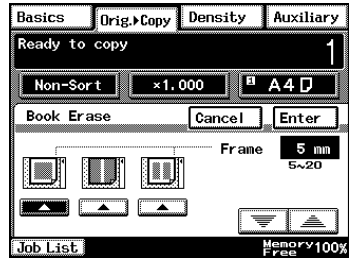

Tip

The pages can be copied with a blank area framing the text.

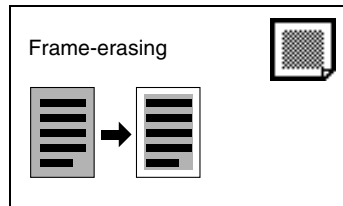

The pages can be copied with a blank area along the binding.

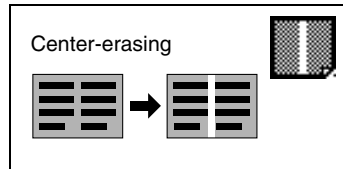

The pages can be copied with a blank area framing the text and along the binding.

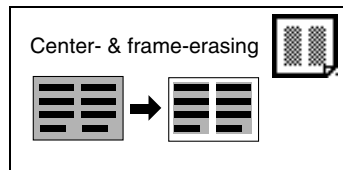

- 8 Touch the big arrow keys to specify the width of the erased area.



Tip

The erased area can be set between 5 mm and 20 mm, in 1 mm increments.

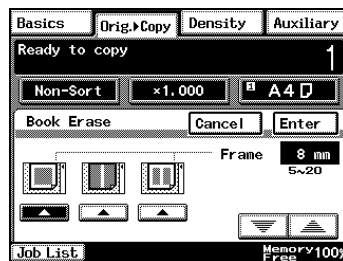

As a default, the width of the area erased along the binding is 12 mm. To change this default setting, consult your service representative.

- 9 Touch [Enter].
- 10 Select the desired copy settings.



Note

If you touch [Book], you can not select [Single-2in1] or [4in1 / Booklet].

- 11 Press the [Start] key.
The copies are printed.

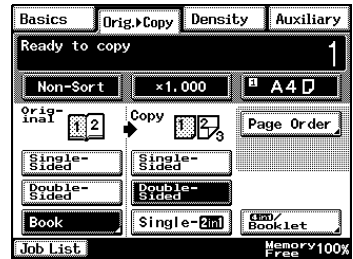

Copying Book Pages onto Separate Double-Sided Pages

- 1 In the Basics screen, touch [Orig. > Copy], and then touch [Book]. The Book screen appears.

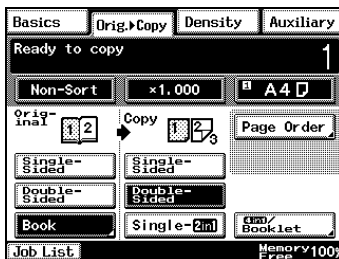

- 2 Select the appropriate setting for the binding position of the book (“Standard Book” or “RightBound”).

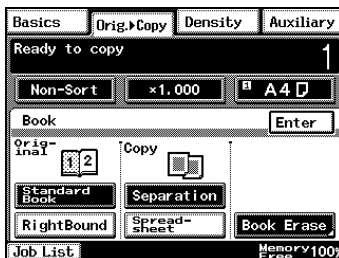

- 3 Touch [Separation], and then touch [Enter].

- 4 Touch [Double-Sided].

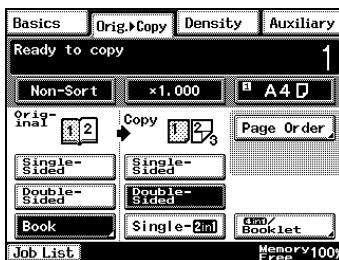

- 5 Touch [Page Order].

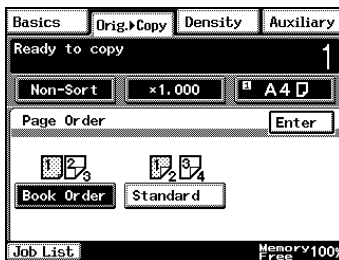

- 6 Select the setting for the desired page order, and then touch [Enter].



Tip
Book page order

Both the left and the right sides are double-sided.

- 7 Press the [Start] key.
The copies are printed.

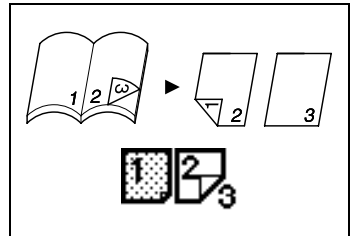
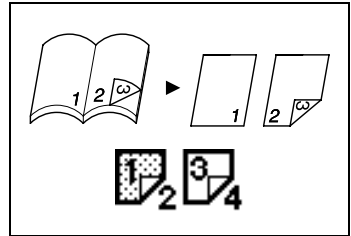

Quickly Selecting Default Settings

The default Orig. ► Copy setting is “Single-Sided > Single-Sided”. The default setting can be changed to “Single-Sided > Double-Sided” or “Double-Sided > Double-Sided”.

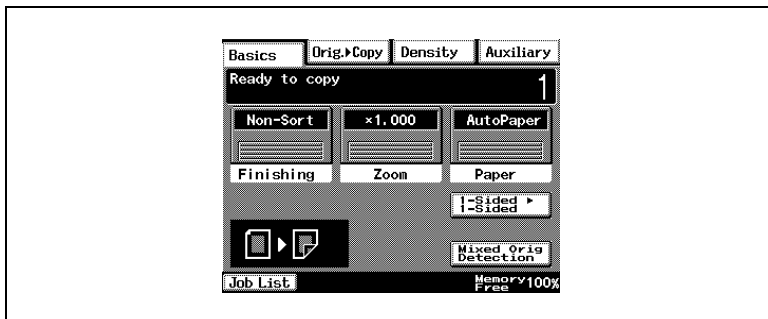

Tip

The default settings can be changed using the various functions on the User's Choice screen. For details, refer to “Changing Default Settings” on page 7-6.

11.4 Specifying a Copy Density

Selecting a Density Setting

In the touch panel, touch [Density]. A screen appears, showing the available Density settings.

Select the appropriate setting for the document to be copied (“Text”, “Photo” or “Text/Photo”). Then, adjust the density as necessary.



Tip

The Density setting “Auto” is the default setting. The default Density setting can be changed using a function on the User’s Choice screen. For details, refer to “Changing Default Settings” on page 7-6.

Selecting the “Text” Setting

Select the “Text” setting to emphasize contours and reproduce text documents with sharpness.

“Auto” Density: The density is automatically adjusted for the document.

1 Position the document(s) to be copied.

- For details, refer to “10 Original Documents”.

2 Touch [Density].

3 Touch [Text].

4 Touch [Auto], or touch [Lighter] and [Darker] to select the desired Density setting.

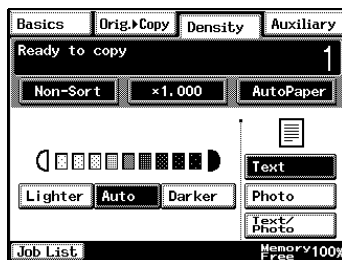

Selecting the “Photo” Setting

Select the “Photo” setting when copying documents with halftones such as photographs.

- 1 Position the document(s) to be copied.
 - For details, refer to “10 Original Documents”.
- 2 Touch [Density].
- 3 Touch [Photo].
- 4 Touch [Lighter] and [Darker] to select the desired Density setting.



Note

The “Auto” Density setting cannot be selected if the “Photo” setting is selected. Selecting the “Auto” setting automatically selects the “Text” setting.

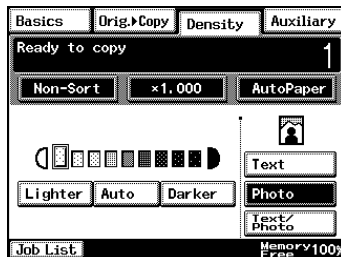

Selecting the “Text/Photo” Setting

Select the “Text/Photo” setting when copying documents containing both text and photos.

- 1 Position the document(s) to be copied.
 - For details, refer to “10 Original Documents”.
- 2 Touch [Density].
- 3 Touch [Text/Photo].
- 4 Touch [Auto], or touch [Lighter] and [Darker] to select the desired Density setting.

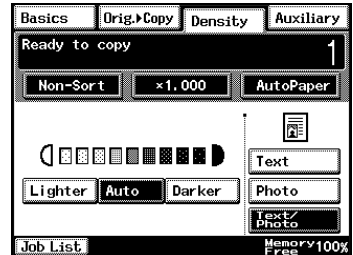

Tip

If the “Auto” Density setting is selected, the density of the copy is adjusted as necessary. However, the density can be made lighter or darker using a function on the User’s Choice screen. For details, refer to “Changing Default Settings” on page 7-6.

12 Touch Panel Messages

12.1 When the Message “Ready to copy Please add toner.” Appears

When the toner is nearly empty, the “Please add toner” message is displayed. After it is displayed, you can still print approximately 1000 pages, however please replace the bottle as soon as possible.

For details, refer to “*To replace the toner bottle*” on page 12-2.

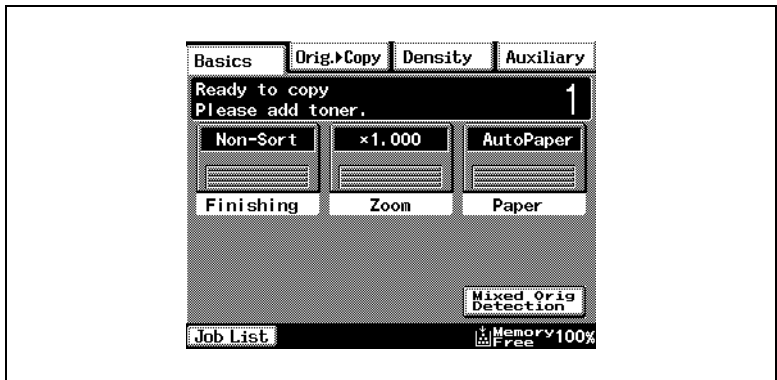

12.2 When the Message “Please add toner.” Appears

When the toner is empty, the message shown below appears and printing can no longer be performed.

Follow the procedure described below to replace the toner bottle.

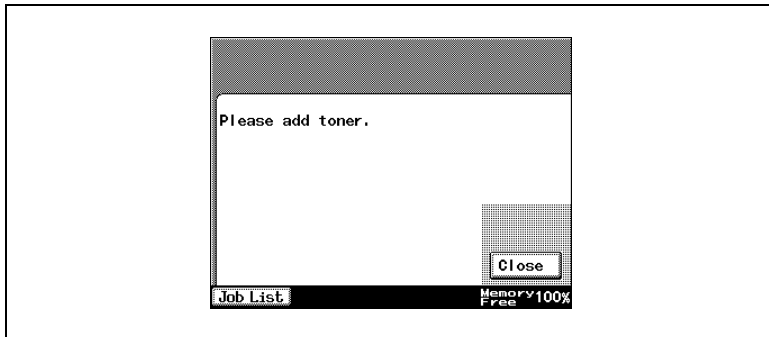

To replace the toner bottle

- 1 Open the front door.
- 2 Pull the toner hopper out as far as possible.

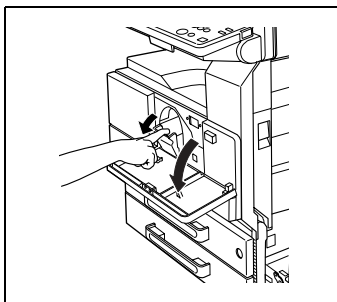

- 3 Flip up the toner bottle holder.

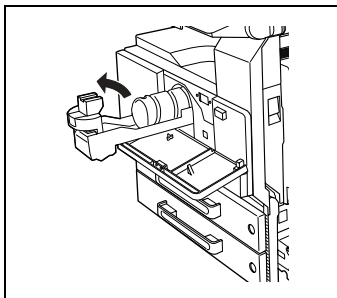

- 4 Carefully pull out the empty toner bottle.
- Do not throw away the empty toner bottle. Instead, keep it so that it can be collected by your service representative.

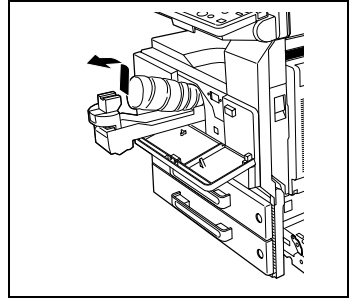

- 5 Hit one end of the new toner bottle against a hard surface, such as a desk or table, 4 or 5 times, and then hit the other end 4 or 5 times.
- Since the toner within the bottle may have become compacted, be sure to break it up by performing this step.

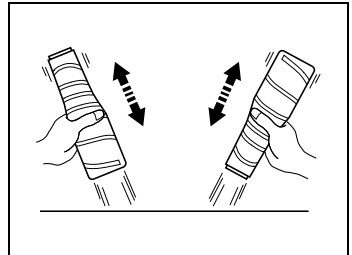

- 6 Shake the new toner bottle up and down about 5 times.

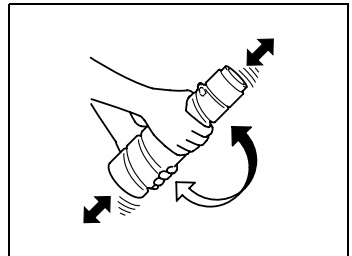

- 7 With the seal on the toner bottle facing upward, insert the bottle.

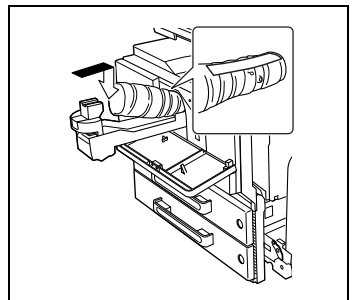

- 8 Flip down on the toner bottle holder until it locks into place. Grab the seal on the toner bottle, and then slowly pull it off toward you.

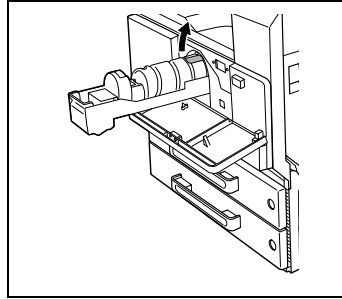

- 9 Fold down the toner bottle holder, and then push in the toner hopper.

- 10 Close the front door.



Note

When the front door is closed, the toner automatically begins refilling.

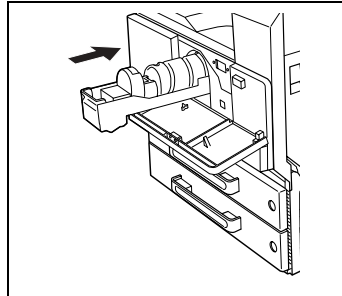

While toner is being refilled, do not turn off the copier or open any other doors.



Tip

If the print is faint immediately after the toner bottle is replaced, replenish the toner. (For more details, refer to "User Management Functions" on page 7-37.)

12.3 When the Message “Stapler empty.” Appears

When the staple cartridge is empty, the message shown below appears and stapling can no longer be performed.

Follow the procedure described below to replace the staple cartridge.

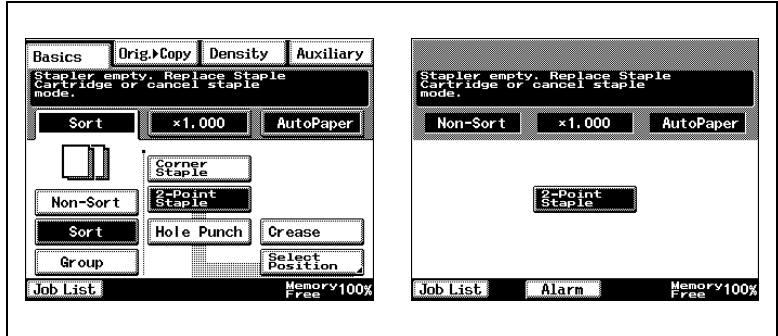

Note

Be sure to replace the staple cartridge only after the message appears. The machine may be damaged if the staple cartridge is removed before the message appears.

To replace the staple cartridge for finisher

- 1 Open the front door.

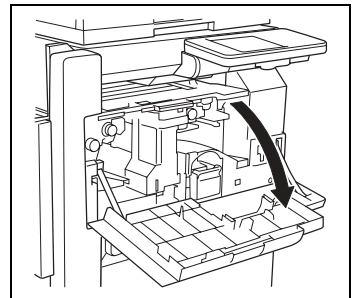

- 2 Pull the staple cartridge holder out toward you.

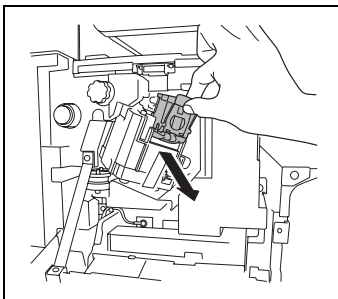

- 3 Press in the area marked "PUSH" to unlock the staple holder.

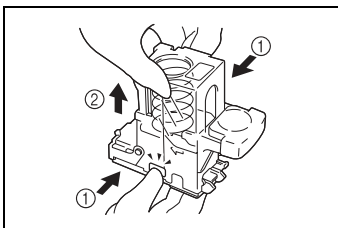

- 4 Remove the empty staple cartridge from the staple cartridge holder.

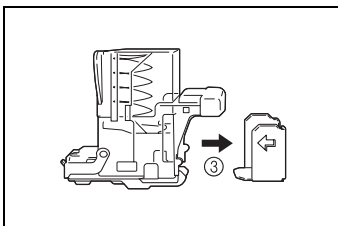

- 5 Insert the new staple cartridge into the staple cartridge holder, and then carefully remove the stopper.

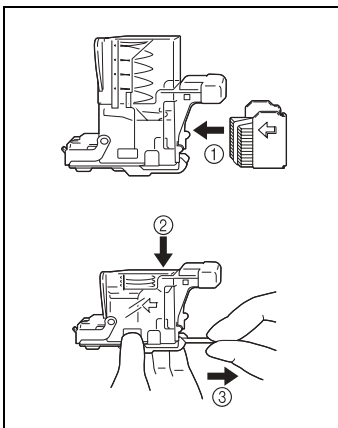

- 6 Insert the refilled staple cartridge holder until it locks into place.
- 7 Close the front door.

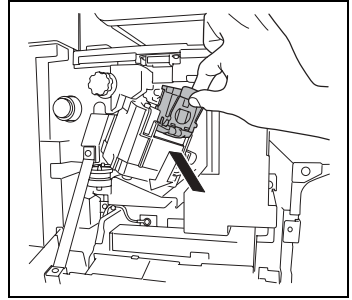

To replace the staple cartridge for the saddle kit

- 1 While holding up the paper output tray, remove the staple cartridge.

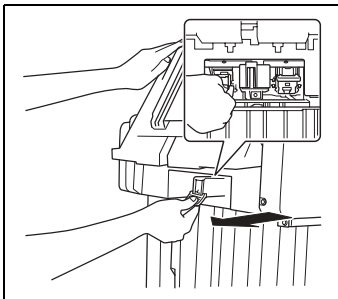

- 2 Press in the area marked "PUSH" to unlock the staple holder.

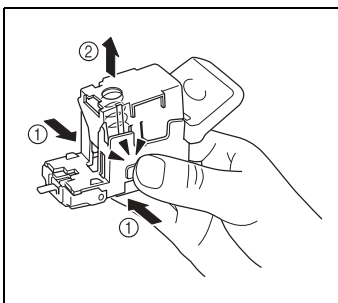

- 3 Remove the empty staple cartridge from the staple cartridge holder.

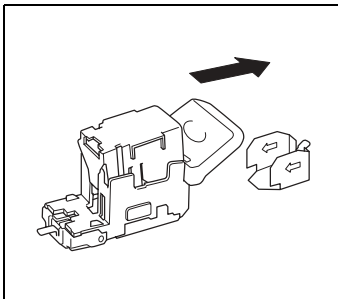

- 4 Insert the new staple cartridge into the staple cartridge holder.

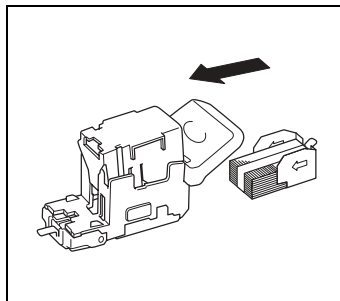

- 5 Carefully remove the stopper.

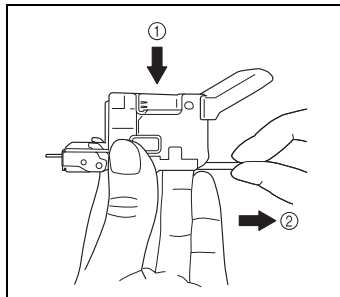

- 6 Insert the refilled staple cartridge holder until it locks into place.



CAUTION

Be careful when installing the staple cartridge holder.

→Be sure that the staple cartridge holder is inserted facing the correct direction.

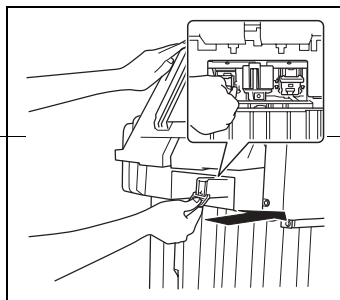

- 7 Lower the paper output tray.

- 8 Open then shut the misfeed-clearing door.

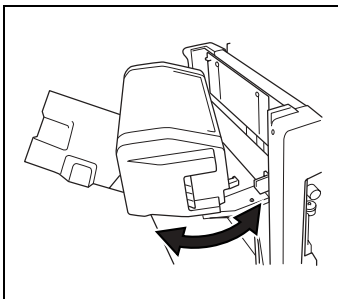

12.4 When a Paper Misfeed Occurs

Locations of Paper Misfeeds

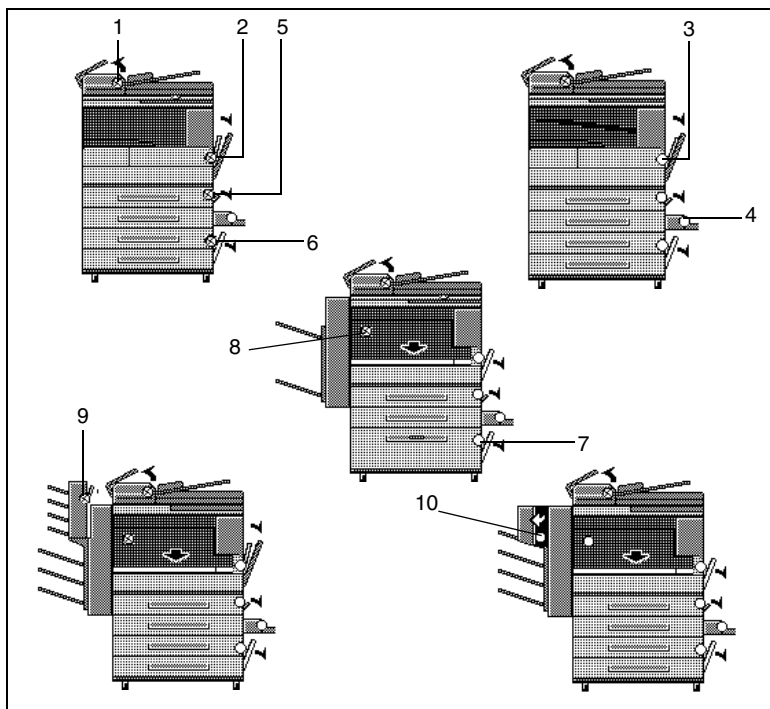

Message	Description	Message	Description
1	A paper misfeed in the duplexing document feeder (page 12-12)	6	A paper misfeed in the 3rd or 4th paper drawer (page 12-20)
2	A paper misfeed in the fusing section (page 12-14)	7	A paper misfeed in the large capacity cabinet (page 12-21)
3	A paper misfeed in the duplex unit (page 12-18)	8	A paper misfeed in the built in finisher (page 12-22)
4	A paper misfeed in the multiple bypass tray (page 12-18)	9	A paper misfeed in the mail bin kit (page 12-24)
5	A paper misfeed in the 1st or 2nd paper drawer (page 12-19)	10	A paper misfeed in the saddle kit (page 12-26)

To clear a paper misfeed in the duplexing document feeder

Follow the instructions that appear in the touch panel to open the document guide and remove any misfed paper.

- 1 Pull up the lever for the misfeed-clearing cover, and then open the cover.

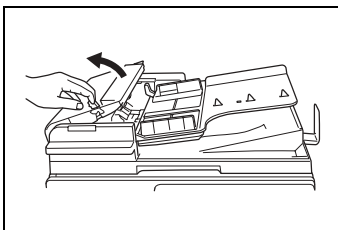

- 2 Carefully pull out any misfed documents.

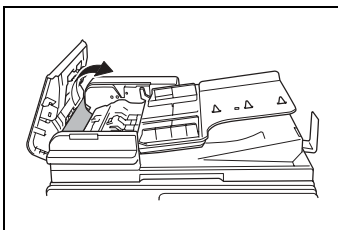

- 3 Swing up the document guide lever.

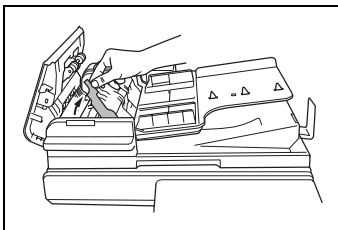

- 4 Turn the dial to feed out any misfed documents.

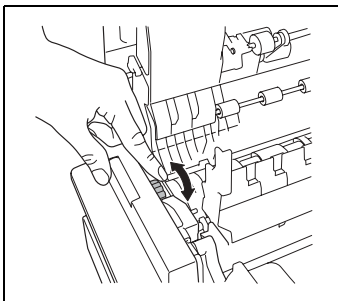

- 5 While supporting the document feed tray with your right hand, carefully pull out any misfed paper.
- 6 Return the document guide to its original position, and then close the misfeed-clearing cover.

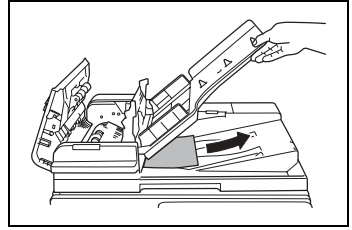

To clear a paper misfeed in the fusing section**CAUTION**

The area around the fusing unit is extremely hot.

- Touching any part other than those indicated may result in burns. If you get burnt, immediately cool the skin under cold water, and then seek professional medical attention.

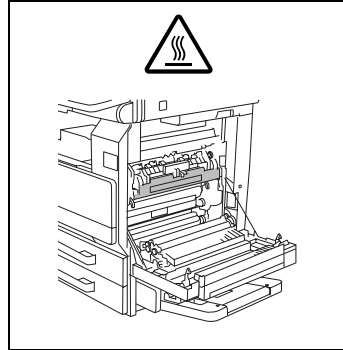

- 1 Pull up the right-side door release lever, and then open the right-side door.

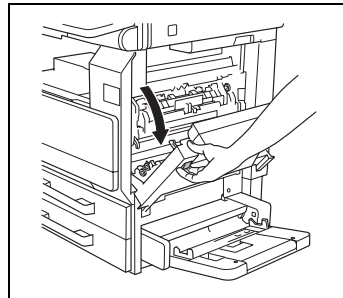

**CAUTION**

Decreased copy quality may result if the surface of the image transfer roller is touched.

→ Be careful not to touch the surface of the image transfer roller.

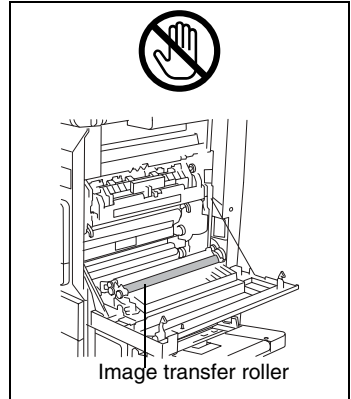

- 2 Carefully pull out any misfed paper.

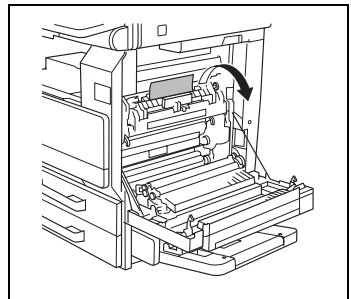

- 3 Open the fusing unit guide.

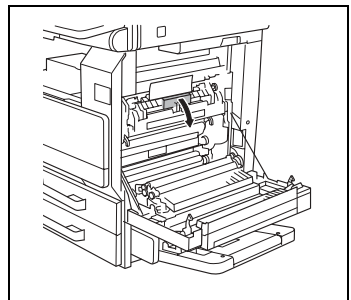

- 4 Carefully pull out any misfed paper.

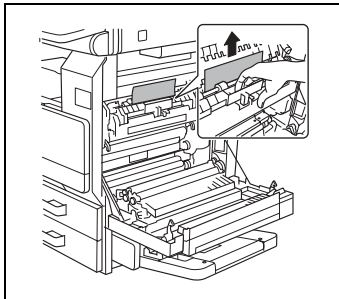

- 5 Open the switching guide, and then carefully pull out any misfed paper in the switchback unit.

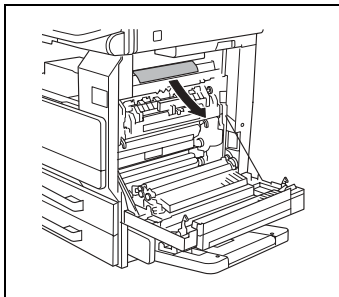

- 6 Carefully pull out any misfed paper in the fusing section.

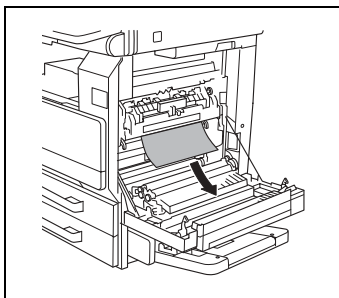

Note

If the paper is misfed as described below, contact your service representative:

The paper is wrapped around the image transfer roller.

The paper is folded or shredded by the image transfer roller.

The paper that was removed tore and partly remains in the fusing unit.

- 7 Carefully pull out any misfed paper around the image transfer roller.

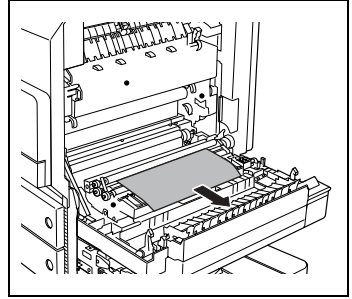

- 8 Carefully pull out any misfed paper.
- 9 Close the right-side door.

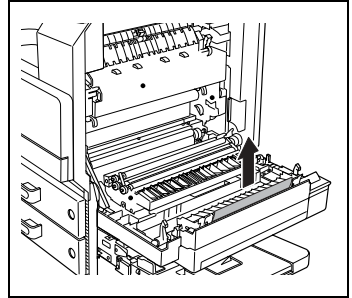

To clear a paper misfeed in the duplex unit

- 1 Open the duplex unit door.
- 2 Carefully pull out any misfed paper.
- 3 Close the duplex unit door.

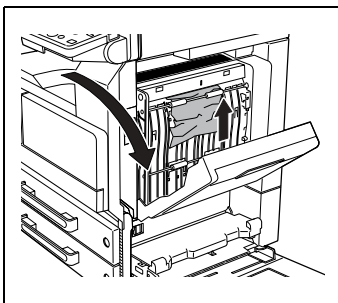
**To clear a paper misfeed in the multiple bypass tray**

- 1 Pull out any misfed paper from the multiple bypass tray.

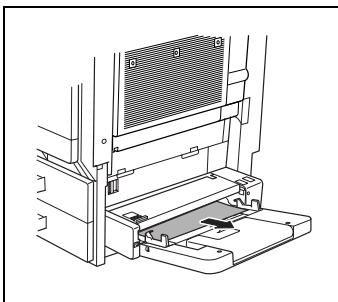

- 2 If the misfed paper cannot be pulled out, pull the lever for the sliding plate of the multiple bypass tray, and then pull the sliding plate toward you.

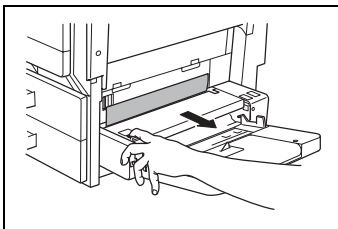

- 3 Press down on the sliding plate with your left hand and carefully pull out any misfed paper.

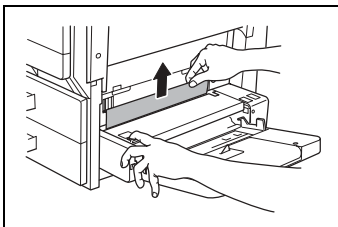

- 4 Return the multiple bypass tray to its original position.

To clear a paper misfeed in the 1st or 2nd paper drawer

- 1 Open the multiple bypass tray.

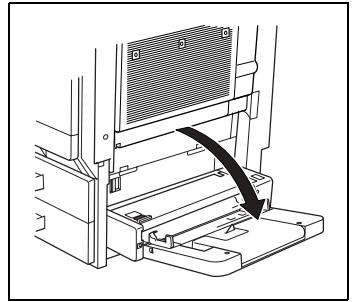

- 2 Pull up the lower-right door release lever to open the lower-right door of the paper feed unit indicated in the touch panel message.

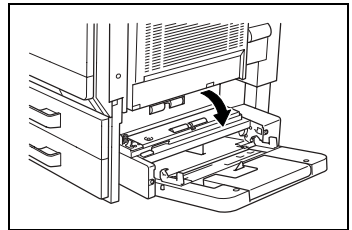

- 3 Carefully pull out any misfed paper.
- 4 Close the lower-right door.
- 5 Close the multiple bypass tray.

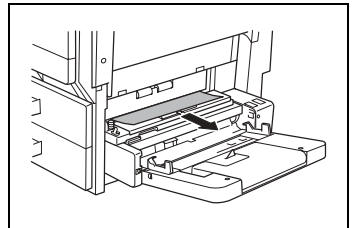

To clear a paper misfeed in the 3rd or 4th paper drawer

- 1 Pull up the lower-right door release lever to open the lower-right door of the paper feed unit indicated in the touch panel message.

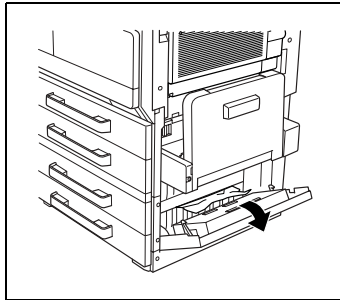

- 2 Carefully pull out any misfed paper.
- 3 Close the lower-right door.

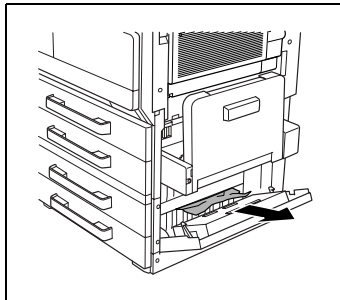

To clear a paper misfeed in the large capacity cabinet

- 1 Pull up the lower-right door release lever to open the lower-right door of the paper feed unit indicated in the touch panel message.

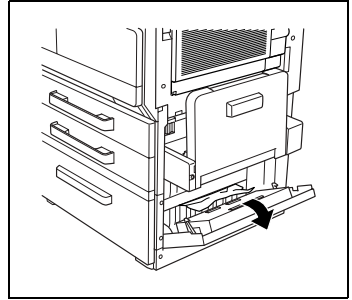

- 2 Carefully pull out any misfed paper.
- 3 Close the lower-right door.

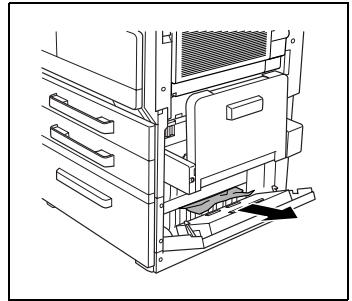

To clear a paper misfeed in the built in finisher

- 1 Open the front door.

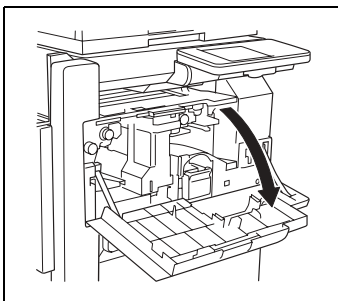

- 2 Lower lever "FN1", and then pull out any misfed paper.

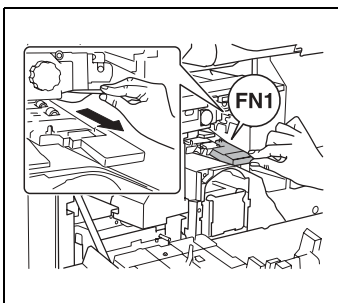

- 3 Turn knob "FN2".

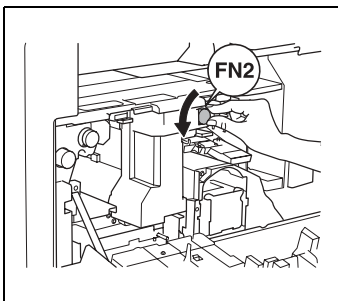

- 4 If the punch kit is installed:
Pull out the punch box.

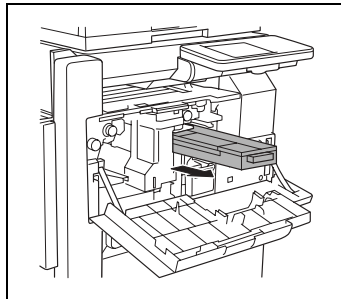

- 5 Lower lever "FN3", and then pull out any misfed paper.

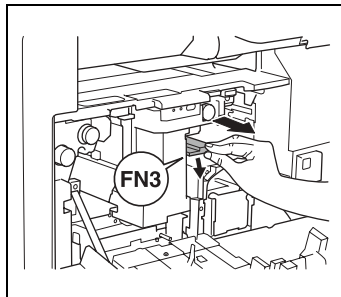

- 6 Return lever "FN1" and lever "FN3" to their original position.

- 7 If the punch kit is installed:
Insert the punch box into its original position.

- 8 Lower lever "FN4".

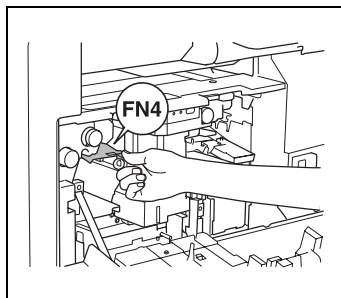

- 9 Turn dial "FN5" or dial "FN6", and then pull out any misfed paper.

- 10 Return lever "FN4" to its original position.

- 11 Close the front door.

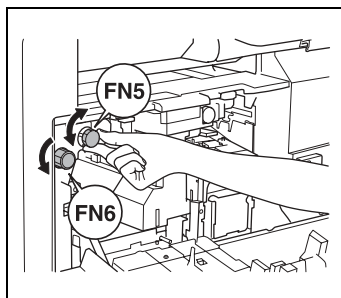

To clear a paper misfeed in the mail bin kit

- 1 Open the front door.

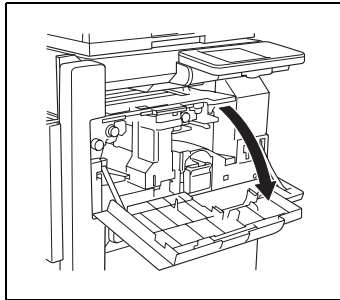

- 2 Turn dial "FN5" or dial "FN6", and then pull out any misfed paper.

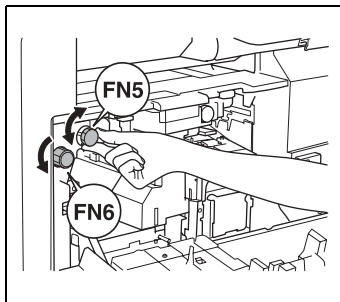

- 3 While pressing down lever "FN7", pull out any misfed paper.

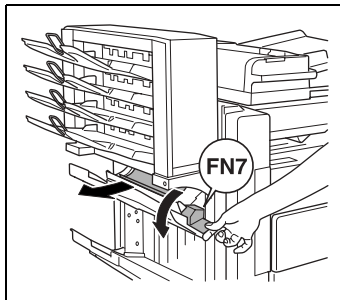

- 4 Pull handle "FN8" to open the misfeed-clearing door.

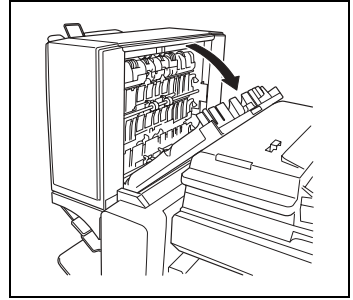

- 5 Pull out any misfed paper in the mail bin.
- 6 Close the misfeed-clearing door.
- 7 Close the front door.

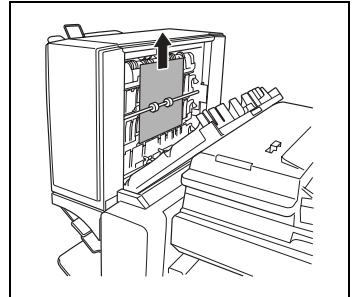

To clear a paper misfeed in the saddle kit

- 1 Open the front door.

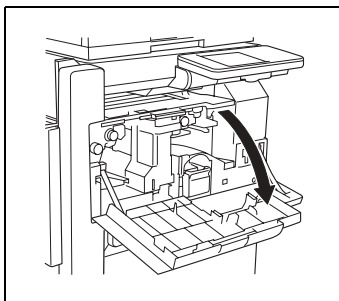

- 2 Turn dial "FN5" or dial "FN6", and then pull out any misfed paper.

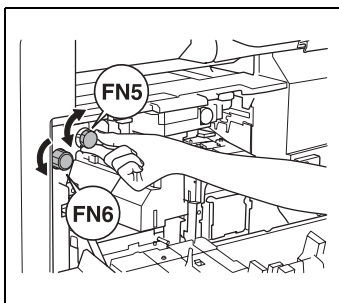

- 3 Remove all paper from the paper output tray.

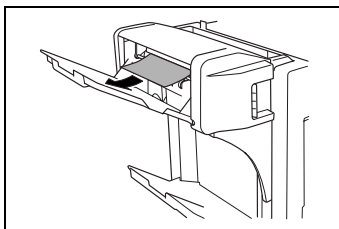

- 4 Open the misfeed-clearing door, and then pull out any misfed paper.

- 5 Close the misfeed-clearing door.

- 6 Close the front door.

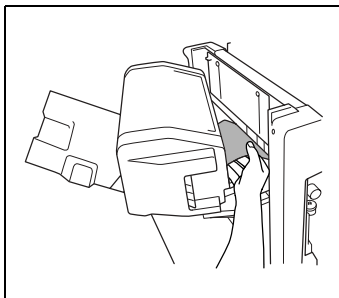

12.5 When the Message “Cannot Staple.” Appears

To clear jammed staples

When a finisher is installed and the staples are jammed, the message shown below appears.

Follow the procedure described below to clear the jammed staples.

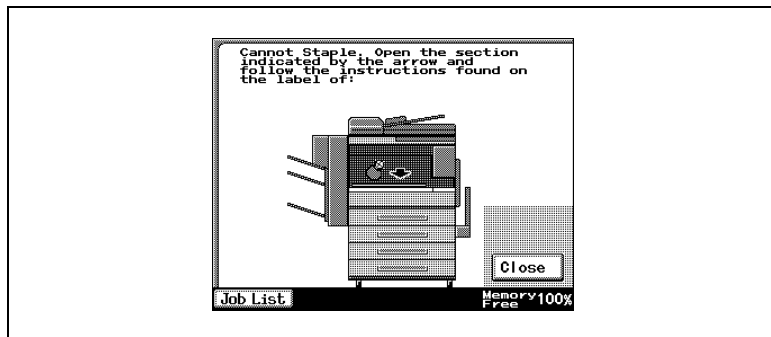

Follow the procedure described below to remove the paper and staples.



Note

When the message “Cannot Staple.” appears, clear the jammed staples as described below.

Not following the following procedure and forcefully pulling out the paper may result in damage to the “Stapler Unit”.

- 1 Remove all paper from the finisher.

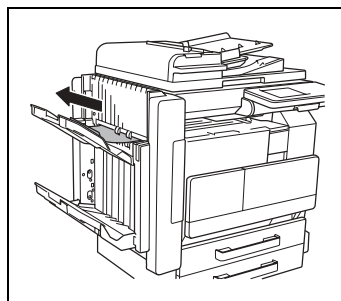

2 Open the front door.

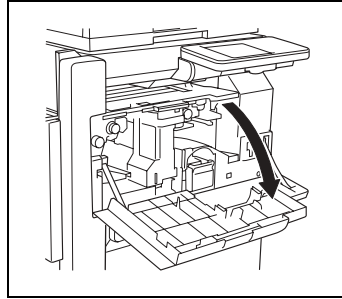

3 Lower lever "FN1", and then pull out any misfed paper.

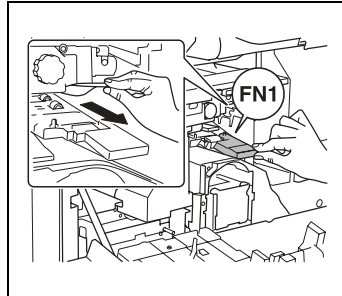

4 Turn dial "FN2".

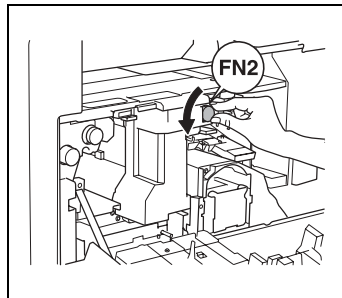

5 If the punch kit is installed:
Pull out the punch box.

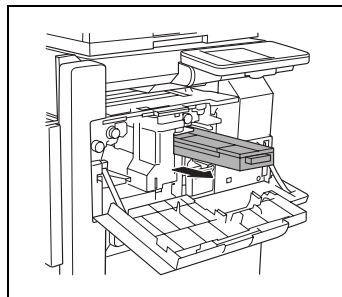

- 6 Lower lever “FN3”, and then pull out any misfed paper.
- 7 Return lever “FN1” and lever “FN3” to their original position.
- 8 If the punch kit is installed:
Insert the punch box into its original position.

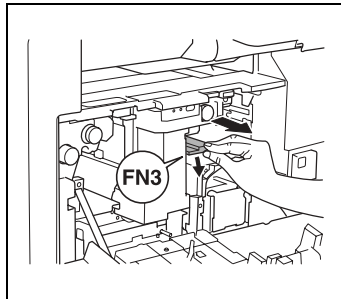

- 9 Lower lever “FN4”.

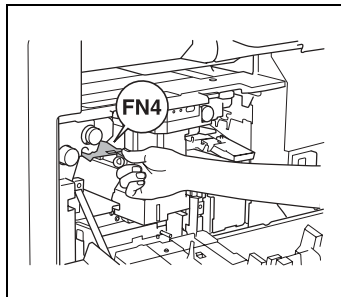

- 10 Turn dial “FN5” or dial “FN6”, and then pull out any misfed paper.

- 11 Return lever “FN4” to its original position.

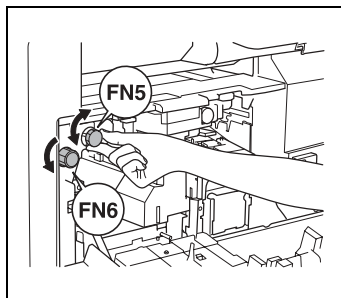

- 12 Turn the dial to the left to move the stapler toward the front.

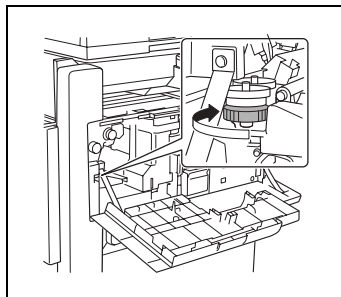

- 13** Pull the staple cartridge holder out toward you.

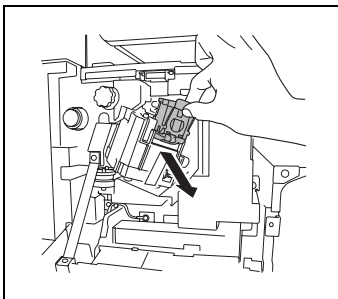

- 14** Push the staple holder guide up, and then pull out one sheet of staples.

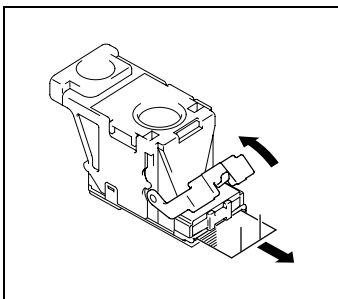

- 15** Return the guide to its original position.

- 16** Insert the staple cartridge holder until it locks into place.

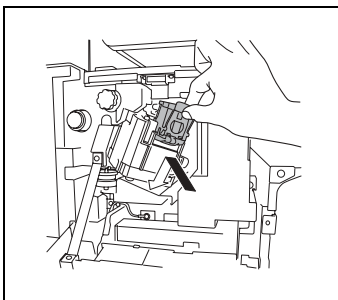

- 17** Close the front door.



Note

If stapling still cannot be performed, even after performing the above procedure, contact your service representative.

12.6 When the Message “Hole Punch collection box is full.” Appears

If the punch kit is attached to the finisher, the following message will appear when the punch box is full.

Follow the procedure described below to empty the punch box.

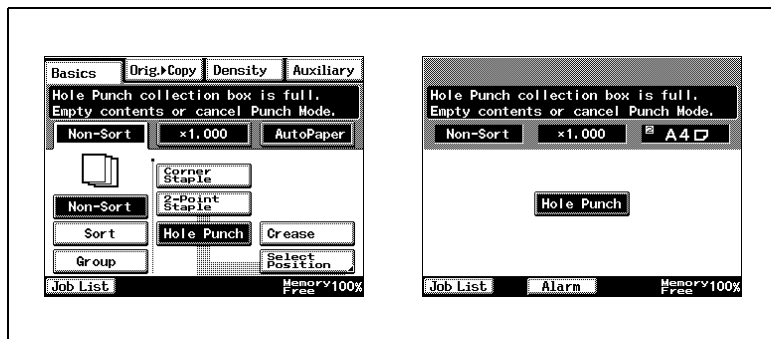

To empty the punch box

Empty and re-install the punch box as described below.

- 1 Open the front door.

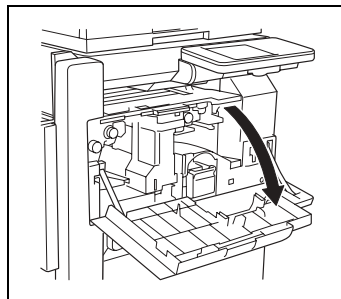

- 2 Pull out the punch box.

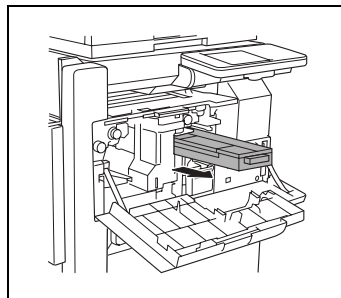

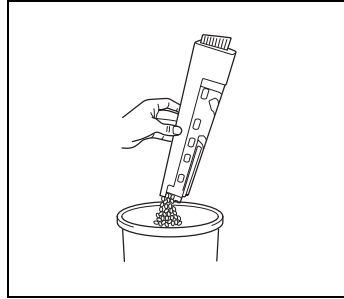

- 3 Empty the punch box.
- 4 Insert the punch box into its original position.
- 5 Close the front door.



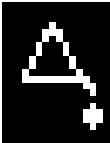

13 Troubleshooting

13.1 Main Messages and Their Remedies

Message	Cause	Remedy
A malfunction was detected. Please call your technical representative and provide the code listed below:	The copier malfunctioned and is unable to print.	Inform your service representative of the code displayed on the touch panel.
Please add toner.	Since the toner has run out, the copier is unable to make copies.	Replace the toner bottle. (<i>"When the Message "Please add toner." Appears" on page 12-2)</i>
The PC Drum needs to be replaced. Call your technical representative.	Since the drum unit has reached the end of its service life, the copier is unable to make copies.	Contact your service representative.
The Imaging Unit needs to be replaced. Call your technical representative.	Since the imaging unit has reached the end of its service life, the copier is unable to make copies.	Contact your service representative.
Stapler empty. Replace Staple Cartridge.	The staples ran out.	Replace the staple cartridge. (<i>"When the Message "Stapler empty." Appears" on page 12-5)</i>
	The time to perform a periodic inspection on the copier has arrived.	Contact your service representative. Touch  to display the code. When contacting the service representative, inform them of the code.
Re-insert the following number of document pages: OO	After clearing a paper misfeed, it is necessary to reload certain pages of the document that have already been fed through the duplexing document feeder.	Load the indicated document pages into the duplexing document feeder.
Cannot XXXXXXXX (not enough free memory). Press Start to resume.	Since the memory is full, no more pages can be scanned.	Print pages or delete queued jobs to clear some of the memory.
This mode cannot be selected with XXXXXXXX.	Functions that cannot be used together are selected.	Make copies using only one of the functions.
Pause.	When making 2in1 copies, the second document page could not be scanned while scanning manually.	Position the second document page or press [Finish].

Message	Cause	Remedy
Properly close the section(s) indicated by the arrow(s).	The door or cover indicated by the arrow is open.	Make sure that all doors and covers are properly closed.
The maximum number of copies allowed for this registered account has been reached. Please contact the administrator.	The total amount of copies as set by the administrator has been reached.	Ask the administrator to clear the number of copies.
The maximum number of jobs to be printed has been reached. Please contact the administrator.	The total amount of jobs to be printed as set by the administrator has been reached.	Ask the administrator to clear the number of jobs to be printed.

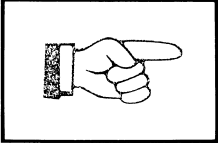
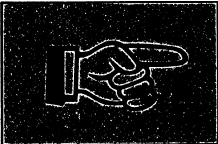
13.2 When Incorrect Copies Are Printed

Symptom	Possible Cause	Remedy
<p>The printed output is too light.</p> 	The "Auto" Density setting is set too light.	Adjust the "Default Copy Output Levels" function on the User's Choice screen. Otherwise, cancel the "Auto" Density setting, and then select the desired setting.
	A Density setting that is too light is selected.	Touch [Density], and then select a darker Density setting.
	Many documents containing photos or large printed areas were printed.	The print density was dark and reduced the toner supply. Use the "Toner Replenisher" function in the Utility mode to replenish the toner.
	The toner bottle was just replaced.	The toner supply was reduced. Use the "Toner Replenisher" function in the Utility mode to replenish the toner until the copy density is darker.
	The toner is empty and the message "Please add toner." appears in the touch panel.	Replace the toner bottle with a new one.
	The paper is damp.	Replace the paper.
<p>The printed output is too dark.</p> 	The "Auto" Density setting is set too dark.	Adjust the "Default Copy Output Levels" function on the User's Choice screen. Otherwise, cancel the "Auto" Density setting, and then select the desired setting.
	A Density setting that is too dark is selected.	Touch [Density], and then select a lighter Density setting.
	The original glass is dirty.	Wipe the glass with a dry soft cloth.
	The document was not pressed close enough against the original glass.	Position the document so that it is pressed closely against the original glass.
<p>The printed output is blurry.</p> 	The paper is damp.	Replace the paper.
	The document was not pressed close enough against the original glass.	Position the document so that it is pressed closely against the original glass.

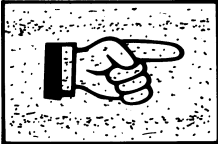
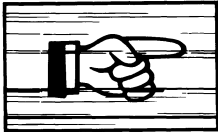
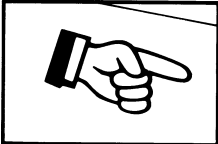
Symptom	Possible Cause	Remedy
<p>There are dark specks or spots throughout the printed output.</p> 	<p>The original glass is dirty.</p>	<p>Wipe the glass with a dry soft cloth.</p>
	<p>Either the document pad is dirty.</p>	<p>Clean the document pad with a soft cloth dampened with a mild detergent.</p>
	<p>The original document is printed on highly translucent material, such as diazo photosensitive paper or overhead projector transparencies.</p>	<p>Place a blank sheet of paper on top of the document.</p>
<p>There are streaks in the printed output.</p> 	<p>A double-sided document is being copied.</p>	<p>If a thin double-sided document is being copied, the information on the back side may be reproduced in the copy. Touch [Density], and then select a lighter density for the background.</p>
<p>The image is not aligned properly on the paper.</p> 	<p>The document is not positioned correctly.</p>	<p>Correctly position the document against the document scales. If the duplexing document feeder is installed, correctly adjust the document guides for the size of the document.</p>
	<p>The document is not positioned correctly in the duplexing document feeder.</p>	<p>Lift open the duplexing document feeder, and correctly position the document against the document scales.</p>
	<p>The original glass is dirty (while using the duplexing document feeder).</p>	<p>Wipe the glass with a dry soft cloth.</p>
	<p>The document guides are not slid up against the edges of the document.</p>	<p>Slide the document guides against the edges of the document.</p>
	<p>Curled paper was loaded into the paper drawer.</p>	<p>Flatten the paper before loading it.</p>
<p>The printed page is curled.</p>	<p>The paper that was used (as with recycled paper) curls easily.</p>	<p>Remove the paper from the paper drawer, turn it over, and then load it again.</p> <p>Replace the paper with paper that is not damp.</p>

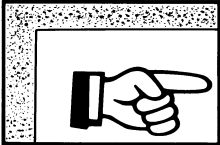
Symptom	Possible Cause	Remedy
<p>The edge of the printed output is dirty.</p> 	The document pad is dirty.	Clean the document pad with a soft cloth dampened with a mild detergent.
	The selected paper size is larger than the document (with Zoom set to "×1.000").	Select a paper size that is the same size as the document. Otherwise, set Zoom to "Auto Size" to enlarge the copy to the selected paper size.
	The orientation of the document is different from the orientation of the copy (with Zoom set to "×1.000").	Select a paper size that is the same size as the document. Otherwise, select a paper orientation that is the same as the that of the document.
	The copy was reduced to a size smaller than the paper (a Custom Zoom setting was selected).	Select a zoom ratio that adjusts the document size to the selected paper size. Otherwise, set Zoom to "Auto Size" to reduce the copy to the selected paper size.

* If the problem is not corrected even after the operations described above are performed, contact your service representative.

13.3 When the Copier Is Not Operating Correctly

Symptom	Possible Cause	Remedy
Nothing appears in the touch panel.	If only the indicator on the [Start] key is lit, the copier is in Energy Saver mode or Sleep mode.	Press any key in the operation panel to cancel Energy Saver mode.
	The copier has not been turned on.	Check that the copier's power switch has been set to "I" and that the sub power switch has been pressed in.
	The contrast control knob for the touch panel has been set either too light or too dark.	While looking at the touch panel, adjust the contrast control knob.
	Has the LCD back-light being set to off?	Please press a key on the control panel or touch panel. Please change the LCD back-light off settings. Refer to "To set the "LCD Back-light Off" function" on page 7-17.
The indicator on the [Start] key does not light up in green.	An access code has not been entered.	Enter the access code according to the procedure described in "Making Copies Using Accounts".
Even though the [Start] key is pressed, no copies are made.	The copy/print job is queued and waiting to be printed.	Touch [Job List] to check the jobs that are queued. Wait until printing begins.
	The copier is still warming up after just being turned on.	The copier takes about 17 seconds to warm up after it is turned on. Wait until the copier has finished warming up.
	The copier is malfunctioning.	Follow any messages that appear on the touch panel.
The machine cannot be set to Copy mode.	The copier is in Interrupt mode (the "Interrupt" indicator is lit). 	Press the [Interrupt] key to cancel Interrupt mode.
The machine cannot be turned on.	The power supply cord has been unplugged from the electrical outlet.	Plug the power supply cord into the electrical outlet.
	The breaker for the electrical circuit has been tripped.	Close the breaker for the electrical circuit.

* If the problem is not corrected even after the operations described are performed, turn off the copier, unplug its power supply cord, and the contact your service representative.

14 Appendix

14.1 Specifications

Copier Di2510/Di3010/Di3510

Specification	
Type	Desktop
Platen	Fixed platen (mirror scanning)
Photo conductor	OPC
Copying system	Digital laser copying
Developing system	MTHG developing method
Fusing system	Heat-roller-fixing system
Resolution	600 dpi
Document	Types: Sheets, books Size: Maximum A3 L, Weight: 3 kg
Paper types	<ul style="list-style-type: none"> • Plain paper (56 g/m² to 90 g/m²), • Recycle paper (56 g/m² to 90 g/m²) • Specialty Paper: thick paper (91 g/m² to 210 g/m²) overhead projector transparencies, postcards, envelopes, label sheets Can only be fed through the multiple bypass tray. Specialty paper can only be used with the multiple bypass tray.
Paper sizes	<p>1st paper drawer, 2nd paper drawer</p> <ul style="list-style-type: none"> • In metric: A3 L, B4 L, A4 L/C, B5 L/C, A5 L • In inch: Ledger L (11 × 17 L), Legal L (8-1/2 × 14 L), Letter L/C (8-1/2 × 11 L/C) (Width: 3-1/2 to 11-3/4 in., Length: 5-1/2 to 17 in.) <p>Multiple bypass tray</p> <p>A3 L, B4 L, A4 L/C, B5 L/C, A5 L/C, B6 L (Width: 90 mm to 297 mm, Length: 140 mm to 432 mm)</p>
Paper capacity	<p>1st paper drawer, 2nd paper drawer</p> <ul style="list-style-type: none"> • Plain paper, recycle paper: 550 sheets each. (64 g/m²) <p>Multiple bypass tray</p> <ul style="list-style-type: none"> • Plain paper, recycle paper: 150 sheets • Specialty paper: 50 sheets • Envelopes: 10 sheets
Warm-up time	Less than 17 seconds when the power switch is on, less than 15 seconds when the sub power switch is on. (at room temperature (23°C))

Specification	
First copy	<p>Di3510 Less than 4.8 seconds (for A4 C paper loaded into the 1st drawer)</p> <p>Di3010/Di2510 Less than 5.3 seconds (for A4 C paper loaded into the 1st drawer)</p>
Copy speed	<p>Di3510 For A4 C paper loaded into the 1st drawer: 35 sheets/min. (A4 C)</p> <p>Di3010 For A4 C paper loaded into the 1st drawer: 30 sheets/min. (A4 C)</p> <p>Di2510 For A4 C paper loaded into the 1st drawer: 25 sheets/min.(A4 C)</p>
Magnification ratios	<ul style="list-style-type: none"> • Full size: $\times 1.000$ • Enlargement ratios: $\times 1.154$, $\times 1.414$, $\times 1.545$ and $\times 2.000$ • Reduction ratios: $\times 0.816$, $\times 0.707$ and $\times 0.500$, minimal ($\times 0.930$) • Zoom ratios: $\times 0.250$ to $\times 4.000$ (in $\times 0.001$ increments)
Multiple copies	1 to 999 sheets
Density control	Automatic, manual and photo manual
Image loss	Leading edge: 4 mm; Trailing edge: 4 mm; Rear edge: 4 mm; Front edge: 4 mm
Power requirements	220-240 V: 10 A 50/60 Hz
Power consumption	Less than 1365 W+10%
Dimensions	677 mm (width) \times 710 mm (depth) \times 718 mm (height)
Memory	64 MB
Weight	74 kg

Duplexing Document Feeder AFR-19

Specification	
Document feed methods	Plain paper: Single-sided and double-sided documents "Mixed Orig Detection" function: Various sizes of single-sided and double-sided documents
Document paper type	Standard method: Plain paper <ul style="list-style-type: none"> • Single-sided: 35 g/m² to 128 g/m² • Double-sided: 50 g/m² to 128 g/m² "Mixed Orig Detection" function: Plain paper (50 g/m ² to 128 g/m ²)
Document paper size	Plain paper: A3 L, B4 L, A4 L/C, B5 L/C, A5 C Mixed document sizes: Refer to the table below.
Capacity of document feeder	Maximum 80 sheets (80 g/m ²)
Power requirements	Supplied by main unit
Power consumption	Less than 48 W
Dimensions	582 mm (width) × 558 mm (depth) × 145 mm (height)
Weight	Less than 9.4 kg

Mixed Width Document Sizes

Maximum Document Width	Mixed Width Document Detection	297 mm		257 mm		210 mm		182 mm	148 mm	123 mm
		A3 L	A4 C	B4 L	B5 C	A4 L	A5 C	B5 L	A5 L	B6 L
297 mm	A3 L	○	○	—	—	—	—	—	—	—
	A4 C	○	○	—	—	—	—	—	—	—
257 mm	B4 L	○	○	○	○	—	—	—	—	—
	B5 C	○	○	○	○	—	—	—	—	—
210 mm	A4 L	○	○	○	○	○	○	—	—	—
	A5 C	—	—	○	○	○	○	—	—	—
182 mm	B5 L	—	—	○	○	○	○	○	—	—
148 mm	A5 L	—	—	—	—	—	—	○	○	—
123 mm	B6 L	—	—	—	—	—	—	—	○	○

○: Copying possible —: Copying not possible

Duplex Unit AD-16

Specification	
Paper type	Plain paper, recycle paper (56 g/m ² to 90 g/m ²)
Paper size	A3 L, B4 L, A4 L/C, A5 L
Power requirements	Supplied by main unit
Power consumption	Less than 10 W
Dimensions	89 mm (width) × 419 mm (depth) × 358 mm (height)
Weight	About 2.2 kg

Switchback Unit SB-1

Specification	
Paper type	Plain paper, recycle paper (56 g/m ² to 90 g/m ²)
Paper size	A3 L, B4 L, A4 L/C, A5 L
Power requirements	Supplied by main unit
Power consumption	Less than 15 W
Dimensions	338 mm (width) × 481 mm (depth) × 148 mm (height)
Weight	About 1.7 kg

Paper Feed Cabinet PF-124

Specification	
Paper type	Plain paper, recycle paper (56 g/m ² to 90 g/m ²)
Paper size	A3 L, B4 L, A4 L/C, B5 L/C
Paper capacity	500 sheets (80 g/m ²)
Power requirements	Supplied by main unit
Power consumption	Less than 15 W
Dimensions	570 mm (width) × 548 mm (depth) × 263 mm (height)
Weight	About 22 kg

2Way Paper Feed Cabinet PF-210

Specification	
Paper type	Plain paper, recycle paper (56 g/m ² to 90 g/m ²)
Paper size	A3 L, B4 L, A4 L/C, B5 L/C, A5 L
Paper capacity	500 sheets × 2 drawers (80 g/m ²)
Power requirements	Supplied by main unit
Power consumption	Less than 15 W
Dimensions	570 mm (width) × 548 mm (depth) × 263 mm (height)
Weight	About 27 kg

Large Capacity Cabinet PF-122

Specification	
Paper type	Plain paper (56 g/m ² to 90 g/m ²)
Paper size	A4 C
Paper capacity	2,500 sheets (80 g/m ²)
Power requirements	Supplied by main unit
Power consumption	Less than 45 W
Dimensions	570 mm (width) × 564 mm (depth) × 263 mm (height)
Weight	About 26 kg

Built in Finisher FN-117

Output trays	1st drawer, 2nd drawer
Settings	<ul style="list-style-type: none"> • Normal functions: "Non-sort", "Sort", "Sort"/"Staple", "Group" and "Saddle Staple" settings • Hole-punch functions: "Non-sort"/"Punch", "Sort"/"Punch" and "Sort"/"Staple"/"Punch" settings
Paper type	<ul style="list-style-type: none"> • Plain paper (56 g/m² to 90 g/m²) • Postcard (190 g/m²) • Envelopes, overhead projector transparencies, label sheets.
Paper size	A3 L, A4 L/C
Paper capacity	<p>1st drawer</p> <ul style="list-style-type: none"> • Plain paper (56 g/m² to 90 g/m²) (A4 L or smaller): Maximum 200 sheets • Postcards, envelopes, overhead projector transparencies and label sheets: Maximum 20 sheets <p>2nd drawer</p> <ul style="list-style-type: none"> • Plain paper (56 g/m² to 90 g/m²) (A4 L or smaller): Maximum 1,000 sheets • B4 L: Maximum 500 sheets • Postcards, envelopes, overhead projector transparencies and label sheets; Maximum 20 sheets
"Staple" setting	Densely printed paper: 2 to 50 sheets
"Punch" setting (option)	Number of punched holes: 4
Power requirements	Supplied by main unit
Power consumption	Less than 66 W
Dimensions	319 (435) mm (width) × 558 mm (depth) × 573 mm (height) (The values within parentheses are the measurements with a media tray installed.)
Weight	About 21.4 kg (including the horizontal transport unit)
Accessories	1 staple cartridge MS-5D (5,000 staples)

Additional Bin Kit AK-1

Specification	
Number of bins	1 Bin
Paper capacity	<ul style="list-style-type: none"> • Plain paper (56 g/m² to 90 g/m²): Maximum 200 sheets • postcards, envelopes, overhead projector transparencies, label sheets: Maximum 20 sheets
Dimensions	282 mm (width) × 368 mm (depth) × 57 mm (height)
Weight	About 0.7 kg

Mail Bin Kit MK-1

Specification	
Number of bins	4 Bins
Paper type	Plain paper, recycle paper (56 g/m ² to 90 g/m ²)
Paper size	A4 C
Paper capacity	Maximum 125 sheets (80 g/m ²) × 4
Dimensions	624 mm (width) × 503 mm (depth) × 390 mm (height)
Weight	About 8 kg (unit weight), less than 12 kg (gross weight)
Power requirements	Supplied by finisher

Punch Kit PK-6

Specification	
Number of punched holes	4 Holes
Paper type	Plain paper, recycle paper (60 g/m ² to 163 g/m ²)
Paper size	A3 L, A4 C
Power requirements	Supplied by finisher
Dimensions	114 mm (width) × 461 mm (depth) × 136 mm (height)
Weight	About 1.9 kg

Saddle Kit SK-1

Specification	
Number of bins	1 Bin
Paper type	Plain paper, recycle paper (56 g/m ² to 90 g/m ²)
Paper size	A3 L, A4 L
Paper capacity	Plain paper (56 g/m ² to 90 g/m ²): 200 sheets
“Staple” setting	Densely printed paper: 2 to 15 sheets
Dimensions	445 (576) mm (width) × 203 (281) mm (depth) × 478 mm (height) (The values within parentheses are the measurements with a media tray installed.)
Weight	9.3 kg
Accessories	1 staple cartridge MS-2C (2,000 staples)
Power requirements	Supplied by finisher

Job Separator JS-203

Specification	
Number of bins	1 Bin (considering the trays of the copier as 2 bins)
Paper type	Plain paper, recycle paper (56 g/m ² to 90 g/m ²) Speciality paper: thick paper (91 g/m ² to 210 g/m ²), overhead projector transparencies, postcards, envelopes, label sheets)
Paper size	A3 L, A4 L/C
Paper capacity	JS-203 100 sheets (80 g/m ²) Copy output tray 250 sheets (80 g/m ²)
Dimensions	450 mm (width) × 443 mm (depth) × 75 mm (height)
Weight	About 1.7 kg

14.2 Care of the Copier

Cleaning

Set the power switch of the copier to "O" before cleaning it.

Housing cover

- Clean the surface of the housing cover by wiping it with a soft cloth dampened with a mild household detergent.

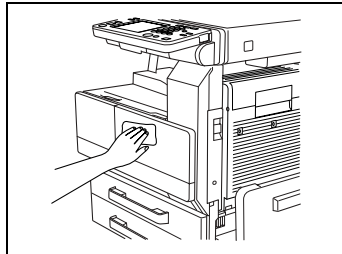

Original glass

- Clean the original glass by wiping it with a soft, dry cloth.

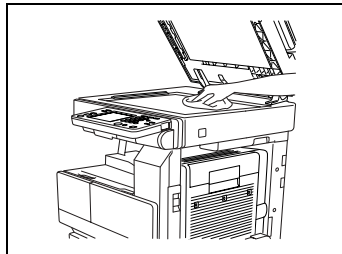

Operation panel

- Clean the operation panel by wiping it with a soft, dry cloth.



Note

Pressing too hard on the operation panel or the touch panel may damage them. In addition, never use mild household detergent or glass cleaner to clean the operation panel or touch panel.

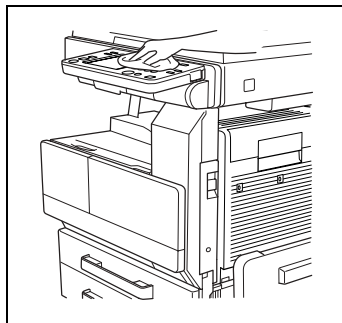

Original glass

- 1 Clean the original glass by wiping it with a soft, dry cloth.

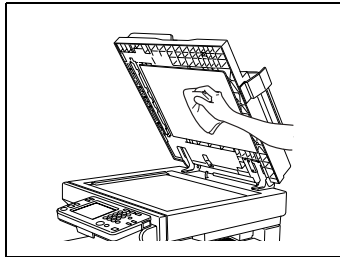

14.3 Function Combination Table

		1	2	3	3	7	9	12				18	19	20		25	26	25										
	Setting selected later	Paper					Number of copies	Zoom			Density			Orig.->Copy (Original)		Orig.->Copy (Copy)												
Setting selected first		Auto Paper	Paper drawer (*1)	Multiple bypass tray (OHP)	Multiple bypass tray (thick paper)	Multiple bypass tray (envelopes)	Multiple bypass tray (plain paper)	Single-sided only paper	Number setting	Auto Size	Preset zoom ratios	Entered zoom ratio	XY Zoom	Auto	Manual setting	Text	Text/Photo	Photo	Single-Sided	Double-Sided	Book (Spreadsheet or Separation)	Book Erase	Single-Sided	Double-Sided	Single-2in1	Double-2in1	Single-4in1	
1	Paper	Auto Paper	△	△	△	△	△	△	△	△	○	○	△	○	○	○	○	○	○	○	○	○	○	○	○	○	○	○
		Paper drawer (*1)	△	△	△	△	△	△	△	△	○	○	○	○	○	○	○	○	○	○	○	○	○	○	○	○	○	○
		Multiple bypass tray (OHP)	△	△	△	△	△	△	△	△	○	○	○	○	○	○	○	○	○	○	○	○	○	○	○	○	○	○
		Multiple bypass tray (thick paper)	△	△	△	△	△	△	△	△	○	○	○	○	○	○	○	○	○	○	○	○	○	○	○	○	○	○
		Multiple bypass tray (envelopes)	△	△	△	△	△	△	△	△	○	○	○	○	○	○	○	○	○	○	○	○	○	○	○	○	○	○
		Multiple bypass tray (plain paper)	△	△	△	△	△	△	△	△	○	○	○	○	○	○	○	○	○	○	○	○	○	○	○	○	○	○
		Single-sided only paper	△	△	△	△	△	△	△	△	○	○	○	○	○	○	○	○	○	○	○	○	○	○	○	○	○	○
	Number of copies	Number setting	○	○	○	○	○	○	○	○	○	○	○	○	○	○	○	○	○	○	○	○	○	○	○	○	○	○
9	Zoom	Auto Size	△	△	△	△	△	△	△	△	△	△	△	△	△	△	△	△	△	△	△	△	△	△	△	△	△	△
		Preset zoom ratios	○	○	○	○	○	○	○	△	△	△	△	△	△	△	△	△	△	△	△	△	△	△	△	△	△	△
		Entered zoom ratio	○	○	○	○	○	○	○	△	△	△	△	△	△	△	△	△	△	△	△	△	△	△	△	△	△	△
		XY Zoom	△	○	○	○	○	○	○	△	△	△	△	△	△	△	△	△	△	△	△	△	△	△	△	△	△	△
	Density	Auto	○	○	○	○	○	○	○	○	○	○	○	○	△	△	△	△	△	△	△	△	△	△	△	△	△	△
		Manual setting	○	○	○	○	○	○	○	○	○	○	○	○	△	△	△	△	△	△	△	△	△	△	△	△	△	△
		Text	○	○	○	○	○	○	○	○	○	○	○	○	△	△	△	△	△	△	△	△	△	△	△	△	△	△
		Text/Photo	○	○	○	○	○	○	○	○	○	○	○	○	△	△	△	△	△	△	△	△	△	△	△	△	△	△
		Photo	○	○	○	○	○	○	○	○	○	○	○	○	△	△	△	△	△	△	△	△	△	△	△	△	△	△
	Orig.-> Copy (Original)	Single-Sided	○	○	○	○	○	○	○	○	○	○	○	○	○	○	○	○	○	○	○	○	○	○	○	○	○	○
		Double-Sided	○	○	○	○	○	○	○	○	○	○	○	○	○	○	○	○	○	○	○	○	○	○	○	○	○	○
		Book (Spreadsheet or Separation)	①	○	○	○	○	○	○	①	○	○	○	○	○	○	○	○	○	○	○	○	○	○	○	○	○	○
		Book Erase	②	○	○	○	○	○	○	②	○	○	○	○	○	○	○	○	○	○	○	○	○	○	○	○	○	○
	Orig.-> Copy (Copy)	Single-Sided	○	○	○	○	○	○	○	○	○	○	○	○	○	○	○	○	○	○	○	○	○	○	○	○	○	○
		Double-Sided	○	○	①	①	①	①	○	○	○	○	○	○	○	○	○	○	○	○	○	○	○	○	○	○	○	○
		Single-2in1	③	○	○	○	○	○	○	○	○	○	○	○	○	○	○	○	○	○	○	○	○	○	○	○	○	○
		Double-2in1	④	○	○	○	○	○	○	○	○	○	○	○	○	○	○	○	○	○	○	○	○	○	○	○	○	○
		Single-4in1	⑤	○	○	○	○	○	○	○	○	○	○	○	○	○	○	○	○	○	○	○	○	○	○	○	○	○
		Double-4in1	⑥	○	○	○	○	○	○	○	○	○	○	○	○	○	○	○	○	○	○	○	○	○	○	○	○	○
		Booklet Creation	⑦	○	①	①	①	①	○	○	○	○	○	○	○	○	○	○	○	○	○	○	○	○	○	○	○	○
		Mixed Orig Detection	○	○	○	○	○	○	○	○	○	○	○	○	○	○	○	○	○	○	○	○	○	○	○	○	○	○
		Original Orientation (*a)	○	○	○	○	○	○	○	○	○	○	○	○	○	○	○	○	○	○	○	○	○	○	○	○	○	○
		Margin (*a)	○	○	○	○	○	○	○	○	○	○	○	○	○	○	○	○	○	○	○	○	○	○	○	○	○	○
	Finishing	Non-Sort	○	○	○	○	○	○	○	○	○	○	○	○	○	○	○	○	○	○	○	○	○	○	○	○	○	○
		Sort	○	○	○	○	○	○	○	○	○	○	○	○	○	○	○	○	○	○	○	○	○	○	○	○	○	○
		Group	○	○	○	○	○	○	○	○	○	○	○	○	○	○	○	○	○	○	○	○	○	○	○	○	○	○
		Staple	○	○	①	①	①	①	○	○	○	○	○	○	○	○	○	○	○	○	○	○	○	○	○	○	○	○
		Hole Punch	○	○	①	①	①	①	○	○	○	○	○	○	○	○	○	○	○	○	○	○	○	○	○	○	○	○
		Center Staple (+ Booklet Creation)	○	○	①	①	①	①	○	○	○	○	○	○	○	○	○	○	○	○	○	○	○	○	○	○	○	○
		Crease (+ Booklet Creation)	○	○	①	①	①	①	○	○	○	○	○	○	○	○	○	○	○	○	○	○	○	○	○	○	○	○

		26	29	30	32	34	35	36	37	38	54	55	39	40	41	41	43	44	46	47	48	50		
		Finishing					Auxiliary																	
	Setting selected later	Double-4in1	Booklet Creation	Mixed Orig Detection	Original Orientation (*b)	Margin (*b)	Non-Sort	Sort	Group	Staple	Hole Punch	Center Staple (+ Booklet Creation)	File Margin	Edge/Frame Erase	Page Insertion	Cover Mode	OHP Interleaving	Image Repeat	Separate Scan	Distribution #	Watermark	Black-White Reverse	Format Printing	Interrupt
	Setting selected first																							
1	Paper	Auto Paper	④	④	○	○	○	○	○	○	○	○	○	○	○	○	○	○	○	○	○	○	○	○
		Paper drawer (*1)	○	○	○	○	○	○	○	○	○	○	○	○	○	○	○	○	○	○	○	○	○	○
		Multiple bypass tray (OHP)	①	①	○	○	○	○	○	①	①	④	④	○	○	○	○	○	○	○	○	○	○	○
		Multiple bypass tray (thick paper)	①	①	○	○	○	○	○	①	①	④	④	○	○	○	○	○	○	○	○	○	○	○
		Multiple bypass tray (envelopes)	①	①	○	○	○	○	○	①	①	④	④	○	○	○	○	○	○	○	○	○	○	○
		Multiple bypass tray (plain paper)	○	○	○	○	○	○	○	○	○	○	○	○	○	○	○	○	○	○	○	○	○	○
		Single-sided only paper	①	①	○	○	○	○	○	○	○	④	④	○	○	○	○	○	○	○	○	○	○	○
	Number of copies	Number setting	○	○	○	○	○	○	○	○	○	○	○	○	○	○	○	○	○	○	○	○	○	○
9	Zoom	Auto Size	○	○	○	○	○	○	○	○	○	○	○	○	○	○	○	○	○	○	○	○	○	○
		Preset zoom ratios	○	○	○	○	○	○	○	○	○	○	○	○	○	○	○	○	○	○	○	○	○	○
		Entered zoom ratio	○	○	○	○	○	○	○	○	○	○	○	○	○	○	○	○	○	○	○	○	○	○
12		X/Y Zoom	②	②	○	○	○	○	○	○	○	④	④	○	○	○	○	○	○	○	○	○	○	○
	Density	Auto	○	○	○	○	○	○	○	○	○	○	○	○	○	○	○	○	○	○	○	○	○	○
		Manual setting	○	○	○	○	○	○	○	○	○	○	○	○	○	○	○	○	○	○	○	○	○	○
		Text	○	○	○	○	○	○	○	○	○	○	○	○	○	○	○	○	○	○	○	○	○	○
		Text/Photo	○	○	○	○	○	○	○	○	○	○	○	○	○	○	○	○	○	○	○	○	○	○
		Photo	○	○	○	○	○	○	○	○	○	○	○	○	○	○	○	○	○	○	○	○	○	○
	Orig.-> Copy (Original)	Single-Sided	○	○	▲	○	○	○	○	○	○	○	○	○	○	○	○	○	○	○	○	○	○	○
		Double-Sided	○	○	○	○	○	○	○	○	○	○	○	○	○	○	○	○	○	○	○	○	○	○
		Book (Spreadsheet or Separation)	△	△	⑥	—	—	○	○	○	○	④	④	③	①	①	①	①	△	○	○	○	○	○
		Book Erase	△	△	⑥	—	—	○	○	○	○	④	④	③	①	①	①	①	△	○	○	○	○	○
	Orig.-> Copy (Copy)	Single-Sided	△	△	○	○	○	○	○	○	○	④	④	○	○	○	○	○	○	○	○	○	○	○
		Double-Sided	△	△	▲	○	○	○	○	○	○	④	④	○	○	○	○	○	○	○	○	○	○	○
		Single-2in1	△	△	①	○	○	○	○	○	○	④	④	○	○	○	○	○	○	○	○	○	○	○
		Double-2in1	△	△	①	○	○	○	○	○	○	④	④	○	○	○	○	○	○	○	○	○	○	○
		Single-4in1	△	△	①	○	○	○	○	○	○	④	④	○	○	○	○	○	○	○	○	○	○	○
		Double-4in1	△	△	①	○	○	○	○	○	○	④	④	○	○	○	○	○	○	○	○	○	○	○
		Booklet Creation	△	△	①	○	○	○	○	⑧	①	○	○	○	○	①	①	①	△	○	○	○	○	○
		Mixed Orig Detection	①	①	○	○	○	○	○	○	○	④	④	○	○	○	○	○	○	○	○	○	○	○
		Original Orientation (*a)	○	○	○	○	○	○	○	○	○	○	○	○	○	○	○	○	○	○	○	○	○	○
		Margin (*a)	○	○	○	○	○	○	○	○	○	○	○	○	○	○	○	○	○	○	○	○	○	○
	Finishing	Non-Sort	○	○	○	○	○	△	△	③	③	○	○	○	○	○	○	○	○	○	○	③	○	○
		Sort	○	○	○	○	△	△	○	○	○	○	○	○	○	○	○	○	○	○	○	○	○	○
		Group	○	○	○	○	△	△	○	○	○	③	○	○	○	○	○	○	○	○	○	○	○	○
		Staple	○	①	○	○	△	△	○	○	○	④	④	○	○	○	○	○	○	○	○	③	○	○
		Hole Punch	○	①	○	○	△	△	○	○	○	④	④	○	○	○	○	○	○	○	○	○	○	○
		Center Staple (+ Booklet Creation)	△	△	⑦	○	○	①	①	—	⑦	○	○	○	○	⑦	⑦	①	△	○	○	○	○	○
		Crease (+ Booklet Creation)	△	△	⑦	○	○	○	○	—	⑦	○	○	○	○	⑦	⑦	①	△	○	○	○	○	○

Function combination codes

Icon	Description
○	The functions can be combined.
—	The functions cannot be combined. Later functions cannot be set.
△	The function set last has priority. No warning message will appear. The function set first will be cancelled.
▲	When making double-sided copies from single-sided documents, later functions cannot be set and a warning message appears.
\	This is not a satisfactory combination since the first function is cancelled when other required simultaneous settings are specified. In addition, the other simultaneous settings are required for the setting selected later.
①	The function set first has priority. A warning message will appear. Later functions cannot be set.
②	The "Auto Size" Zoom setting is selected.
③	The "Sort" setting is automatically selected.
④	The zoom setting specified using the "Multiple-in-1 and Booklet Copy Zoom" function on the User's Choice screen is recalled.
⑤	The function selected first is not performed.
⑥	The function selected later is not performed.
⑦	The zoom setting specified using the "Multiple-in-1 and Booklet Copy Zoom" function on the User's Choice screen is recalled.
⑧	The "2-Point Staple" setting is automatically changed to the "Center Staple" setting. The "Corner Staple" setting cannot be selected.
⑨	These functions cannot be selected if the document is fed through the duplexing document feeder. The function set first has priority. No warning message will appear. The function selected later is not performed.
⑩	These functions cannot be selected if the document is fed through the duplexing document feeder. The function set later has priority. No warning message will appear. The function selected first is not performed.
⑪	The setting changes according to the setting specified from the User's Choice screen.
⑫	The settings can be specified, but the function selected first is not performed.
⑬	The settings can be specified, but the function selected later is not performed.
⑭	This setting cannot be selected since the "Booklet Creation" setting is not selected.
*a	The function selected first is not performed if documents of mixed sizes are being copied. (*2)
*b	The function selected later is not performed if documents of mixed sizes are being copied. (*2)
⑰	This setting cannot be selected since the "Booklet Creation" setting is selected.

Icon	Description
Ⓔ	This setting cannot be selected since the "Book" setting is selected.
Ⓕ	This setting cannot be selected since the "Book" setting cannot be selected.
■	A warning message should appear.
■	The settings can be selected, but either the function will automatically be cancelled or the function is not performed.

14.4 Paper Size and Zoom Ratio Tables

Paper Sizes

Paper Format	Metric Size	English Size
A3 Wide	311 mm × 457 mm	12-1/4 in. × 18 in.
A3	297 mm × 420 mm	11-3/4 in. × 16-1/2 in.
A4	210 mm × 297 mm	8-1/4 in. × 11-3/4 in.
A5	148 mm × 210 mm	5-3/4 in. × 8-1/4 in.
A6	105 mm × 148 mm	4-1/4 in. × 5-3/4 in.
B4	257 mm × 364 mm	10 in. × 14-1/4 in.
B5	182 mm × 257 mm	7-1/4 in. × 10 in.
B6	128 mm × 182 mm	5 in. × 7-1/4 in.

Paper Format		English Size	Metric Size
Ledger		11 in. × 17 in.	279 mm × 432 mm
11 in. × 14 in.		11 in. × 14 in.	279 mm × 356 mm
Computer		10-1/8 in. × 14 in.	257 mm × 356 mm
10 in. × 14 in.		10 in. × 14 in.	254 mm × 356 mm
9-1/4 in. × 14 in.		9-1/4 in. × 14 in.	236 mm × 356 mm
Legal		8-1/2 in. × 14 in.	216 mm × 356 mm
Foolscap	Government Legal	8-1/2 in. × 13 in.	216 mm × 330 mm
Foolscap		8 in. × 13 in.	203 mm × 330 mm
Foolscap		8-2/3 in. × 13 in.	220 mm × 330 mm
Foolscap	Folio	8-1/4 in. × 13 in.	210 mm × 330 mm
8-1/4 in. × 11-3/4 in.		8-1/4 in. × 11-3/4 in.	210 mm × 301 mm
Letter		8-1/2 in. × 11 in.	216 mm × 279 mm
Government Letter		8 in. × 10-1/2 in.	203 mm × 267 mm
Quarto		8 in. × 10 in.	203 mm × 254 mm
Statement	Invoice	5-1/2 in. × 8-1/2 in.	140 mm × 216 mm
4 in. × 6 in.		4 in. × 6 in.	102 mm × 152 mm

Zoom Ratios

Metric Sizes		
Document Paper Size	Desired Paper Size	Zoom Ratio
A3 297 mm × 420 mm 11-3/4 in. × 16-1/2 in.	A4	× 0.707
	A5	× 0.500
	B4	× 0.866
	B5	× 0.610
A4 210 mm × 297 mm 8-1/4 in. × 11-3/4 in.	A5	× 0.707
	A6	× 0.500
	B5	× 0.866
	B6	× 0.610
	A3	× 1.414
A5 148 mm × 210 mm 5-3/4 in. × 8-1/4 in.	B4	× 1.224
	A6	× 0.707
	B6	× 0.866
	A4	× 1.414
	A3	× 2.000
A6 105 mm × 148 mm 4-1/4 in. × 5-3/4 in.	B4	× 1.733
	B5	× 1.224
	A4	× 2.000
	A5	× 1.414
	B5	× 1.733
B4 257 mm × 364 mm 10 in. × 14-1/4 in.	B6	× 1.224
	A4	× 0.816
	A5	× 0.577
	B5	× 0.707
	B6	× 0.500
B5 182 mm × 257 mm 7-1/4 in. × 10 in.	A3	× 1.154
	A5	× 0.816
	A6	× 0.577
	B6	× 0.707
	A3	× 1.640
	A4	× 1.154
B4	B4	× 1.414

Metric Sizes		
Document Paper Size	Desired Paper Size	Zoom Ratio
B6 128 mm × 182 mm 5 in. × 7-1/4 in.	A6	× 0.816
	A4	× 1.640
	A5	× 1.154
	B4	× 2.000
	B5	× 1.414

English Sizes		
Document Paper Size	Desired Paper Size	Zoom Ratio
Ledger 11 in. × 17 in. 279.4 mm × 431.8 mm	11 in. × 14 in.	× 0.823
	Legal	× 0.722
	Foolscap	× 0.764
	Letter	× 0.647
	Invoice	× 0.500
11 in. × 15 in. 279.4 mm × 381 mm	11 in. × 14 in.	× 0.933
	Legal	× 0.772
	Foolscap	× 0.772
	Letter	× 0.733
	Invoice	× 0.500
11 in. × 14 in. 279.4 mm × 355.6 mm	Legal	× 0.772
	Foolscap	× 0.772
	Letter	× 0.772
	Invoice	× 0.500
Legal 8-1/2 in. × 14 in. 215.9 mm × 355.6 mm	Foolscap	× 0.928
	Letter	× 0.785
	Invoice	× 0.607
	11 in. × 17 in.	× 1.214
Foolscap 8-1/2 in. × 13 in. 215.9 mm × 330.2 mm	Letter	× 0.846
	Invoice	× 0.647
	11 in. × 17 in.	× 1.294
	11 in. × 14 in.	× 1.076
Letter 8-1/2 in. × 11 in. 215.9 mm × 279.4 mm	Invoice	× 0.647
	11 in. × 17 in.	× 1.294
	11 in. × 14 in.	× 1.272

English Sizes		
Document Paper Size	Desired Paper Size	Zoom Ratio
Invoice 5-1/2 in. × 8-1/2 in. 139.7 mm × 215.9 mm	11 in. × 17 in.	× 2.000
	11 in. × 14 in.	× 1.647
	Legal	× 1.545
	Foolscap	× 1.529
	Letter	× 1.294

Zoom ratio = Paper size/Document size

1 in. (inch) = 25.4 mm

1 mm = 0.0394 in. (inch)

14.5 Consumables

In order to maintain the condition of this machine, the following consumables are needed.

For best copy quality, we recommend that the specified supplies be used.

For information on or for purchasing supplies, contact your nearest technical representative.

Paper

In addition to plain paper, thick paper and overhead projector transparencies are also available.



Note

In order to protect unwrapped paper from humidity, keep it in a plastic bag and stored in a cool, dark location.

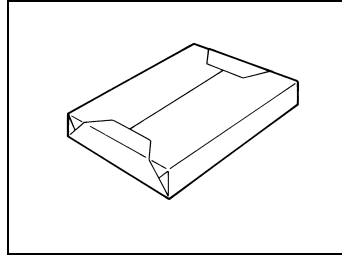

Toner Bottle

Toner is the black powder used to create the text and lines.



Note

Only use toner that has been manufactured specifically for this copier.

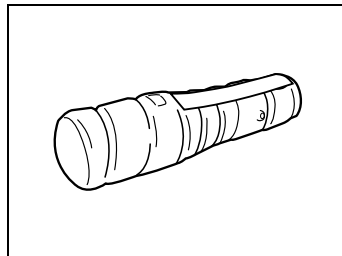

Do not throw away the used toner cartridges. Instead, keep them in their boxes to be collected by your service representative.

Staple Cartridges

MS-5D for the finisher

Staples for staple binding

5,000 staples are provided in the staple cartridge.

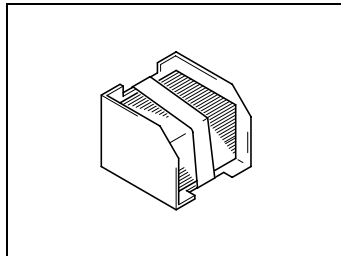

MS-2C for the saddle kit

Staples for staple binding

2,000 staples are provided in the staple cartridge.

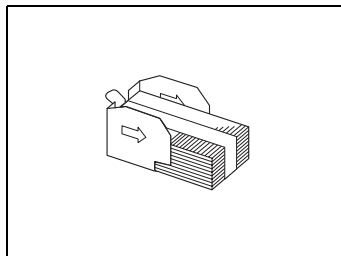

14.6 Index

Numerics

1st paper drawer	1-12
1st paper output tray	1-15
2 Way paper feed cabinet	1-7
2nd paper drawer	1-12
2nd paper output tray	1-15
2-point staple	11-2
2way Paper feed cabinet	14-5
3rd paper drawer	1-14, 1-16
3rd paper output tray	1-16
4th paper drawer	1-14

A

Accessibility	4-5
Account management	8-10
Account registration	8-16
Additional bin kit	1-8, 1-16, 14-6
Additional message display	4-19
Administrator code	8-6
Administrator management	8-1
Administrator settings	8-6
Auto panel reset	4-14, 7-18
Auto paper	7-10
Auto size	7-10
Automatically selecting the paper source	9-6
Available functions and settings	4-19

B

Basic copy operations	5-1
Black-White reverse	6-19
Book	11-20, 11-25
Bound document	11-23
Built in finisher	1-8, 14-6

C

Care of the copier	14-9
Checking the settings	4-3
Clearing jammed staples	12-27
Consumables	14-20
Control panel	1-12, 4-1
10-Key Pad	4-2
Access key	4-1
Accessibility key	4-2
Clear key	4-1
Contrast dial	4-2
Copy key	4-1
Enlarge Display key	4-2
Extra Scan key	4-1
Interrupt key	4-1
Mode Check key	4-2
Panel Reset key	4-1
Scan key	4-1
Start key	4-2
Stop key	4-2
sub power switch	4-1
touch panel	4-1
Utility key	4-2
Copy density	11-31
Copy desk	1-7
Copy program	7-34
Copy track mode	5-5
Corner staple	11-2
Cover mode	6-1, 6-3
Crease/Center staple	7-29
Crisscross grouping	11-5
Custom paper size	9-14

D

Date and time	8-3
Default settings	4-17
Density	7-21, 7-23
Distribution #	6-14
Document feed tray	1-14
Document guides	1-14

Document output tray	1-14
Document pad	1-12
Document scales	1-12
Double-2in1	11-18
Double-4in1	11-19
Double-sided	11-18
Drawer priority	7-11
Drawer release button	1-16
Duplex unit	1-12, 14-4
Duplex unit door	1-12
Duplexing document feeder	1-7, 14-3
Duplexing document feeder connector	1-13

E

Edge/Frame erase	6-10, 6-11
Empty the punch box	12-31
Energy save mode	4-14, 7-15
Enlarging the touch panel screens	4-11

F

Feeding the document	10-1
duplexing document feeder	10-4
File margin	6-8
Finisher	1-8
Free penalty	8-23
Front door	1-11
Function combination table	14-11

G

Group	11-2
-------------	------

H

Hard disk drive	1-9
Hole punch	11-3
Hole punch setting	11-8

I

ID key	7-19
Image repeat	6-12
Image stamp	7-31
Image stamping	6-17
Initial settings	8-3
Installation site	2-10
Interrupting a copy job	5-4

J

Job list screen	4-20
Job separator	1-7, 14-8

L

Landscape	1-4
Language selected	7-8
Large capacity cabinet	1-7, 1-16, 14-5
LCD back-light off	7-17
Legal restrictions on copying	2-15
Loading documents for specific applications	10-12
Loading paper	9-7
large capacity cabinet	9-9
multiple bypass tray	9-10
paper drawer	9-8
Lower-right door	1-16
Lower-right door release lever	1-14

M

Mail bin	1-15
Mail bin kit	1-8, 14-7
Making copies using accounts	5-5
Memory	1-9
Memory recall	4-24, 7-6
Message display	4-19
Messages	13-1
Meter count	7-33
Misfeed-clearing door	1-15, 1-16

Mixed original detection	7-7, 10-6
Mixed width document sizes	10-2, 14-3
Multiple bypass tray	1-11
Multiple-in-1	
2in1 copy	7-14
4in1 copy	7-14, 7-20

N

Non-sort	11-1
Non-standard paper size	9-14

O

OHP Interleaving	6-6
Operating environment	2-12
Operation precautions	2-12
Orig. > Copy settings	11-18
specifying	11-21
Original cover kit	1-7
Original glass	1-12
Output tray	7-26
Output tray cover	1-15
Overhead projector transparencies	9-1, 9-13

P

Page insertion	6-4, 6-5
Panel cleaning	7-38
Paper	14-20
Paper feed cabinet	1-8, 14-4
Paper feeding	1-3
Paper guide	1-11
Paper misfeed	
1st or 2nd paper drawer	12-19
3rd or 4th paper drawer	12-20
duplex unit	12-18
duplexing document feeder	12-12
finisher	12-22
fusing section	12-14
large capacity cabinet	12-21

mail bin kit	12-24
multiple bypass tray	12-18
saddle kit	12-26
Paper misfeeds	
locations	12-11
Paper orientation	1-4
Paper output tray	1-11, 1-16
Paper setting	9-19
Paper sizes	14-16
Paper specifications	9-1
Paper stopper	1-11, 1-14
Paper storage	9-5
Paper supply	1-5
Paper supply indicator	1-11
Plug-in counter	7-19
Portrait	1-4
Positioning documents	
original glass	10-8
Power cord socket	1-13
Power source	2-10
Power switch	1-13
Print area	9-5
Print indicator	1-14
Printer controller	1-9
Punch kit	1-9, 14-7

R

Replacing the staple cartridge	
finisher	12-5
saddle kit	12-8
Replacing the toner bottle	12-2
Right-side door	1-11
Right-side door release lever	1-11

S

Saddle kit	1-8, 1-16, 14-7
Scanner dry	7-28
Screen tabs	4-19

Selected settings	4-19
Separate scan	6-20
Shift grouping	11-5
Shift sorting	11-4
Single-2in1	11-18
Single-4in1	11-19
Single-sided	11-18
Sleep mode	4-15, 7-16
Soft switches	8-21
Sort	11-1
Space requirements	2-11
Special paper	7-12
Specifications	14-1
Specify the date and time	8-3
Staple cartridges	14-21
Stapling setting	11-6
Stopping copying	5-3
Switchback unit	1-12, 14-4

T

Time zone	8-5
Toner bottle	14-20
Toner replenisher	7-40
Touch panel	1-11, 4-17
Tray extension	1-11
Turning the copier on and off	4-12

U

Useful operations	3-1
User management	7-37
Utility mode	7-1

W

Watermark	6-16
-----------------	------

X

X/Y zoom setting 11-17

Z

Zoom ratios 14-17

Zoom setting 11-13

Free Manuals Download Website

<http://myh66.com>

<http://usermanuals.us>

<http://www.somanuals.com>

<http://www.4manuals.cc>

<http://www.manual-lib.com>

<http://www.404manual.com>

<http://www.luxmanual.com>

<http://aubethermostatmanual.com>

Golf course search by state

<http://golfingnear.com>

Email search by domain

<http://emailbydomain.com>

Auto manuals search

<http://auto.somanuals.com>

TV manuals search

<http://tv.somanuals.com>