

**E** INSTRUCTION MANUAL

**DYNAX**<sup>™</sup>  
**505si**  
**SUPER**  
**MAXXUM**<sup>®</sup>  
**XTsi**



MINOLTA

QUICK  
OPERATION

GETTING  
STARTED

FULL-AUTO  
OPERATION

SUBJECT  
PROGRAM  
SELECTION

CREATIVE  
EXPOSURE  
MODES

ADDITIONAL  
FEATURES

APPENDIX

## FOR PROPER AND SAFE USE

This manual has been designed to help you understand the operation of your Minolta camera more quickly. After familiarizing yourself with the camera, start with Level I and learn to operate the camera in Full-Auto mode.

Move on to Level II and the Subject Program modes when you are comfortable with the camera and want to have more control. Here you decide the type of image you want to photograph and leave the exposure details to the camera.

When you are ready for full control, move on to Level III and the ASM exposure modes.

The information in this manual is relevant for products introduced before December, 1998. Contact the nearest authorized Minolta Service facility to obtain compatibility information for products released after this date.

This device complies with Part 15 of the FCC Rules. Operation is subject to the following two conditions: (1) This device may not cause harmful interference, and (2) this device must accept any interference received, including interference that may cause undesired operation. Changes or modifications not approved by the party responsible for compliance could void the user's authority to operate the equipment. This equipment has been tested and found to comply with the limits for a Class B digital device, pursuant to Part 15 of the FCC Rules. These limits are designed to provide reasonable protection against harmful interference in a residential installation. This equipment generates, uses and can radiate radio frequency energy and, if not installed and used in accordance with the instructions, may cause harmful interference to radio communications. However, there is no guarantee that interference will not occur in a particular installation. If this equipment does cause harmful interference to radio or television reception, which can be determined by turning the equipment off and on, the user is encouraged to try to correct the interference by one or more of the following measures:

- Reorient or relocate the receiving antenna.
- Increase the separation between the equipment and the receiver.
- Connect the equipment to an outlet on a circuit different from that to which the receiver is connected.
- Consult the dealer or an experienced radio/TV technician for help.

This Class B digital apparatus complies with Canadian ICES-003.



This mark certifies that this product meets the requirements of the EU (European Union) concerning interference causing equipment regulations. CE stands for Conformité Européenne (European Conformity).

**Read and understand all warnings and cautions before using this product.**

### **WARNING**

Batteries may become hot or explode due to improper use.

- Use only the batteries specified in this instruction manual.
- Do not install the batteries with the polarity (+/-) reversed.
- Do not subject batteries to fire or high temperatures.
- Do not attempt to recharge, short, or disassemble.
- Do not mix batteries of different types, brands, or ages.
- Tape over lithium battery contacts before disposal.
- Follow local regulations for battery disposal.

Use caution, accidents may occur when using this product near young children.

Keep batteries and other things that could be swallowed away from young children. Contact a doctor immediately if an object is swallowed.

Immediately remove the batteries and discontinue use if...

- the camera is dropped or subjected to an impact in which the interior is exposed.
- the camera emits a strange smell, heat, or smoke.

Do not disassemble. Electric shock may occur if a high voltage circuit inside the camera is touched. Take your camera to a Minolta Service Facility when repairs are required.

Do not look directly at the sun through the viewfinder.

### **CAUTION**

Do not allow a camera lens to point directly at the sun. Fire may occur if sunlight comes to focus on a flammable surface. Replace the lens cap when the product is not being used.

## TABLE OF CONTENTS

<b>LEVEL I</b>	<b>NAMES OF PARTS</b> .....4
	<b>QUICK OPERATION</b> .....8
	<b>GETTING STARTED</b>
	Strap .....11
	Batteries .....12
	Lens .....14
	Loading Film .....16
	Handling the Camera .....18
	Eye-Start .....19
	<b>FULLY-AUTOMATIC OPERATION</b>
Taking Pictures in Full-Auto .....21	
Focus Signals .....22	
Special Focus Situations.....23	
Focus Hold .....24	
Using the Built-in Flash	
Flash signals.....26	
Flash range.....26	
Fill flash .....27	
Flash cancel .....27	
Red-eye reduction .....28	
Rewinding the Film .....29	
<b>SUBJECT PROGRAM SELECTION</b>	
Portrait Mode .....31	
Landscape Mode .....32	
Close-up Mode .....33	
Sports Mode .....34	
Night Portrait Mode.....35	
Photographing Night Scenes .....36	
Self-timer.....37	
Continuous Advance .....38	

## TABLE OF CONTENTS

<b>CREATIVE EXPOSURE MODES</b>	
A-MODE – Aperture Priority .....40	
A-mode flash .....41	
Aperture control .....42	
S-MODE – Shutter Priority .....43	
S-mode flash .....44	
Shutter control .....45	
M-MODE – Manual .....46	
Metering in manual mode.....47	
M-mode flash .....48	
TAKING TIME EXPOSURES (buLb) .....49	
<b>ADDITIONAL FEATURES</b>	
<b>FOCUS</b>	
Wide Focus Area .....52	Spot AF.....53
Manual Focus.....54	AF Illuminator .....55
<b>EXPOSURE</b>	
14 Segment Metering .....56	Spot Metering.....57
Exposure Compensation ..58	Setting the ISO Manually ..59
Bracketing.....60	Multiple Exposure .....63
<b>FLASH</b>	
High-Speed Sync .....66	Slow Sync.....67
Wireless/Remote Flash ...68	
<b>FOR OWNERS OF THE PANORAMA MODEL.....73</b>	
<b>FOR OWNERS OF THE DATE MODEL</b>	
Exposing the Date/Time ....74	Setting the Date/Time.....75
Replacing the Battery .....76	
<b>CUSTOM FUNCTIONS</b>	
Setting .....77	Details.....78
<b>APPENDIX</b>	
Program Reset Button .....83	Accessories .....84
Exposure Warnings .....87	Trouble Shooting .....88
Care and Storage .....90	Specifications .....92

## NAMES OF PARTS

For information on specific parts, refer to the page numbers shown in parenthesis.

### Body

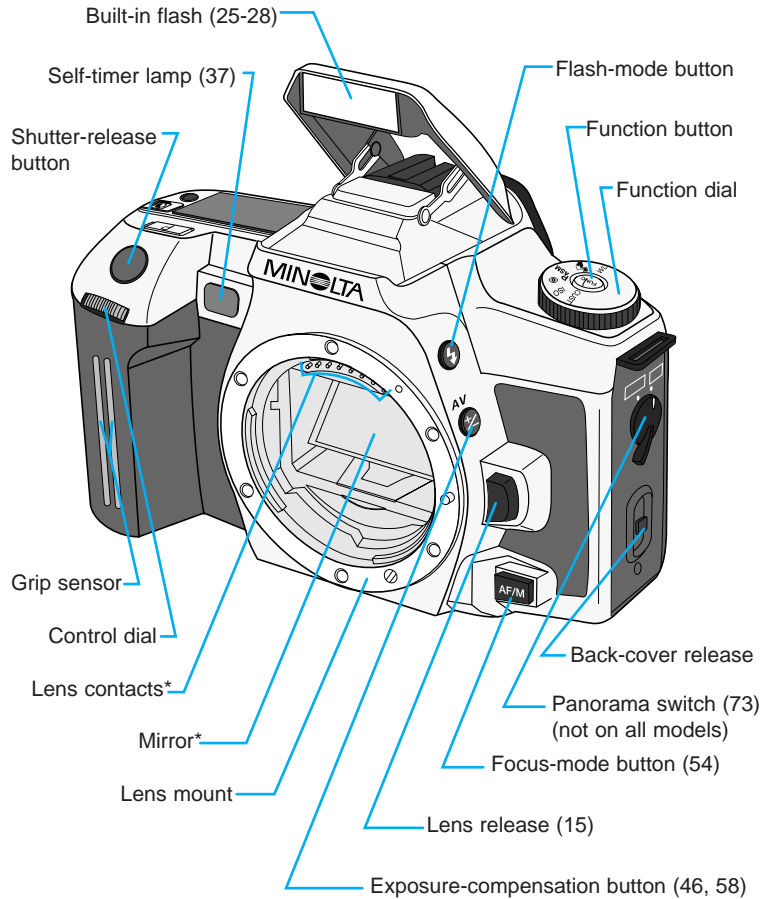

\* Do not touch

## NAMES OF PARTS

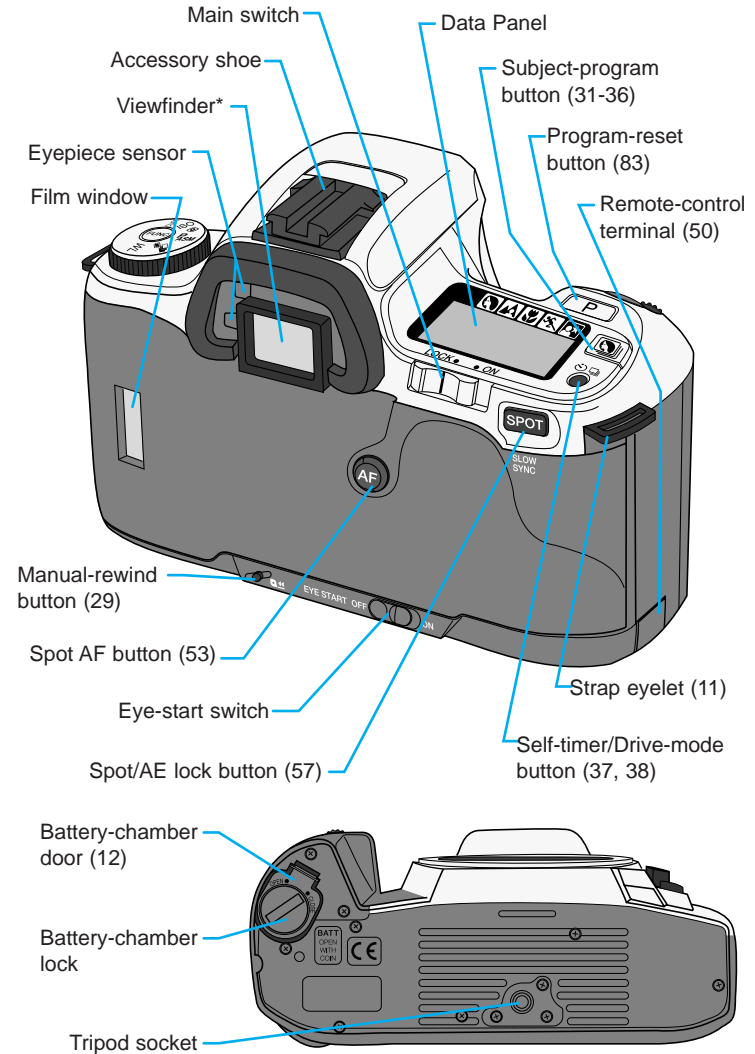

## NAMES OF PARTS

### Data Panel

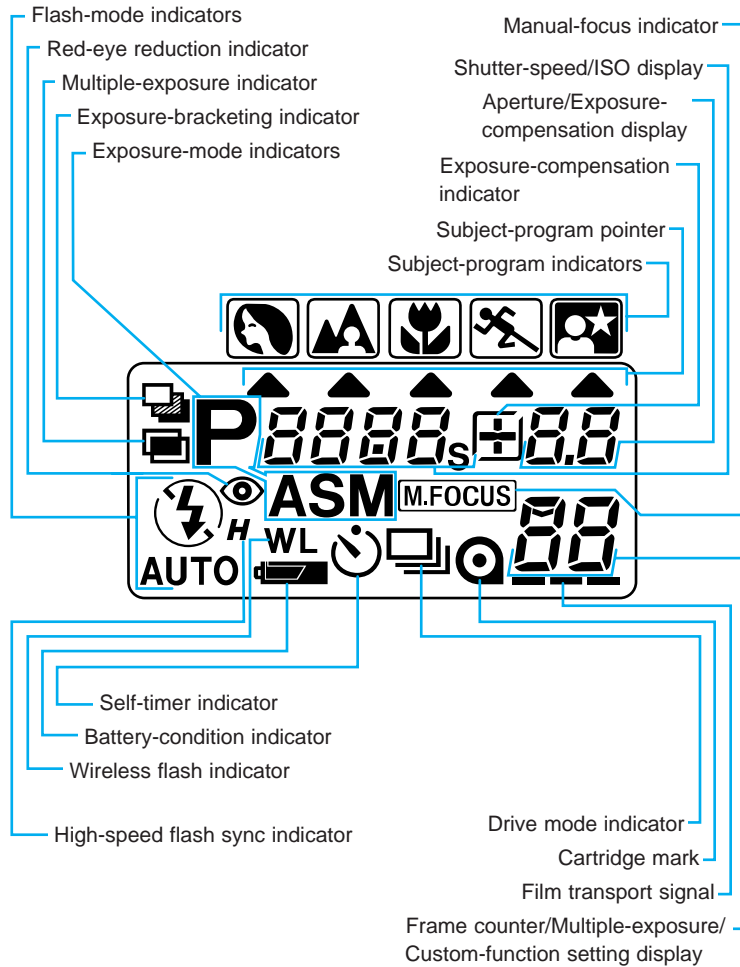

6

## NAMES OF PARTS

### Viewfinder

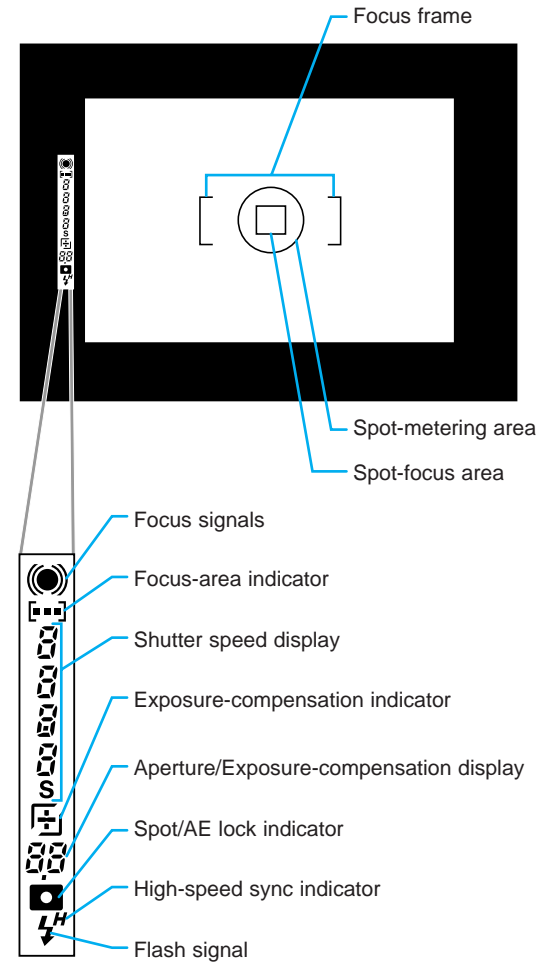

7

## QUICK OPERATION

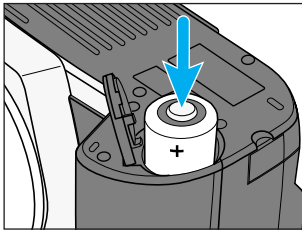

### 1. Insert batteries.

- This camera uses two CR2 lithium batteries.

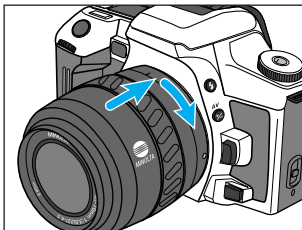

### 2. Attach lens.

- Align the red mounting dot on the lens with the one on the camera. Gently insert the lens into the mount and turn it clockwise until it clicks into the locked position.

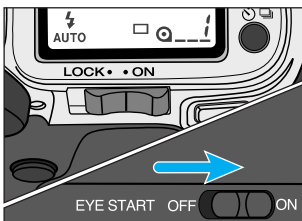

### 3. Slide the main and eye-start switches to ON.

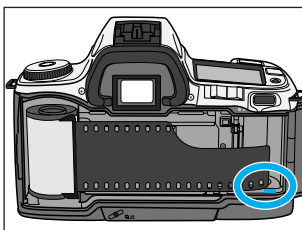

### 4. Load film.

- Align the film tip with the red mark, then close the back cover.

## QUICK OPERATION

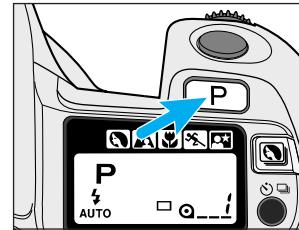

### 5. Set Full-Auto operation.

- Press the program-reset button to set the camera to fully-automatic operation.

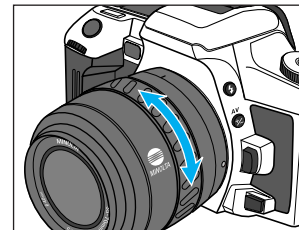

### 6. If using a zoom lens, rotate the zooming ring to frame your subject as desired.



### 7. Center your subject in the focus frame.

- The camera will focus and set exposure automatically.

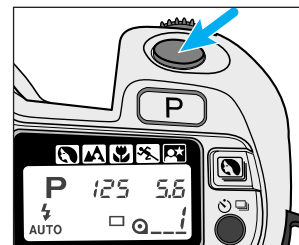

### 8. Take the picture.

- Gently press the shutter-release button all the way down to take the picture.

# LEVEL I

This section provides the information necessary to operate your camera in most photographic situations.

This section covers:

- Battery Installation
- Attaching and Removing the Lens
- Loading the Film
- Camera Handling
- Fully Automatic Camera Operation
- Special Focus Situations
- Basic Flash Operation
- Rewinding the Film

Once you fully understand the instructions in this section, proceed to Level II, Level III, and Additional Features to obtain more enjoyment from your camera.

# GETTING STARTED

## Attaching the Strap

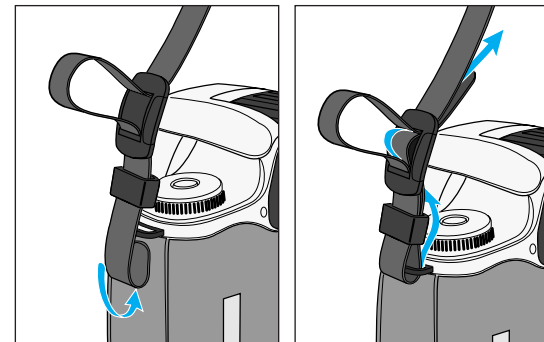

## BATTERIES

### Installing the Batteries

Your camera uses two 3V CR2 lithium batteries to supply power for all camera operations.

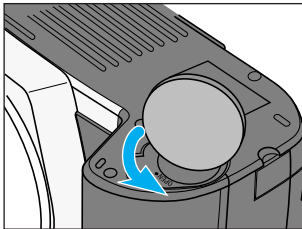

1. Using a coin or similar object, turn the battery-chamber lock to OPEN, then open the battery-chamber door.

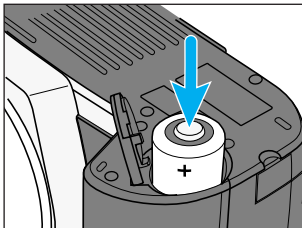

2. Insert the batteries as indicated by the + and - marks.

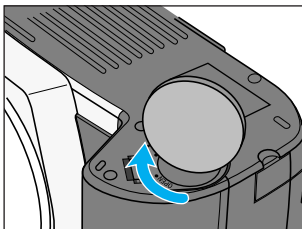

3. Close the battery-chamber door, then turn the battery-chamber lock to CLOSE.
  - Setting the camera down with the battery-chamber door open may damage the camera.

## BATTERIES

### Checking Battery Power

Each time the main switch is set to ON, a battery symbol appears in the data panel indicating the power status of the batteries.

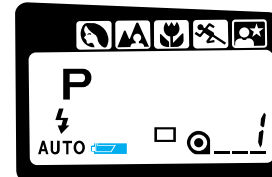

#### Full-battery symbol

Power is sufficient for all camera operations.

-  will only appear for five seconds.

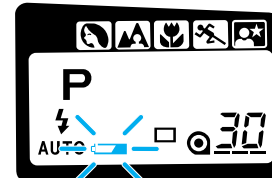

#### Blinking low-battery symbol

Power is extremely low. All functions are operational, but the batteries will need to be replaced soon. Flash recycling time may be slow.

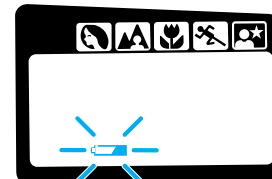

#### Blinking low-battery symbol appears alone and the shutter locks.

Power is insufficient for camera operation. Replace the batteries.



#### No display

Power is too low for the camera to operate. Replace the batteries or make sure they have been inserted correctly.



## LENS

### Attaching the Lens

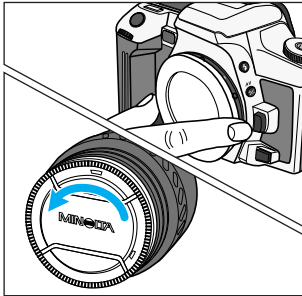

1. Remove the body and rear lens caps.

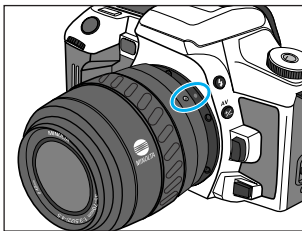

2. Align the red mounting dots on the lens and camera body.

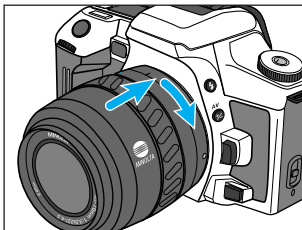

3. Gently insert the lens into the mount, then turn it clockwise until it clicks into the locked position.
- Do not insert the lens at an angle.
  - Do not press the lens release when attaching the lens.

## LENS

### Removing the Lens

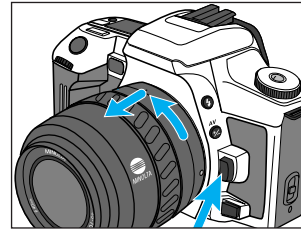

1. Press the lens release and turn the lens counter-clockwise until it stops.

2. Gently remove the lens and replace caps, or attach another lens.

#### Caution

- Do not force the lens if it does not turn smoothly.
- Do not touch the inside of the camera, especially the lens contacts and mirror.

## LOADING FILM

Check the film window before loading film. If film is loaded, do not open the back cover. Refer to Manual Rewind on page 29 for instructions on removing a partially exposed roll.

- Load film in the shade to reduce the chances of fogging the film.
- Do not use Polaroid Instant 35mm film. Winding problems may occur.
- If DX-coded film is used, the camera automatically sets the correct ISO (film speed).
- If non DX-coded film is used, the camera will use the previous roll's ISO setting. Refer to page 59 to set the film speed manually.
- Do not use infrared film in this camera. The camera's frame counter sensor will fog infrared film.

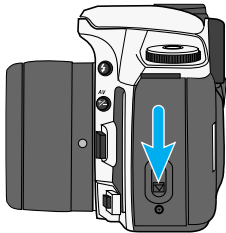

- 1. Slide the back-cover release down to open the back cover.**

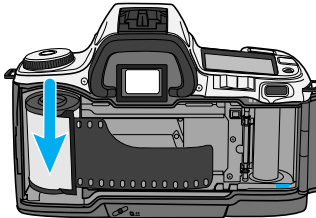

- 2. Insert a film cartridge into the film chamber.**

The shutter curtain's precision design makes it extremely sensitive to pressure. Never touch it with your fingers or the film tip.

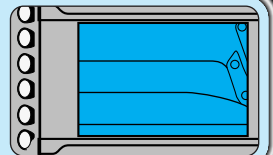

## LOADING FILM

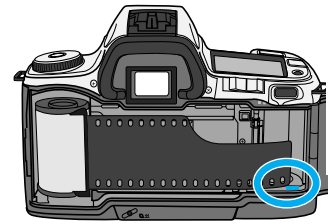

- 3. Extend the leader between the guide rails to the index mark.**

- If the film tip extends beyond the index mark, push the excess film back into the cartridge.

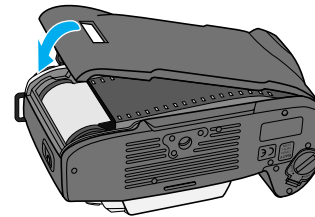
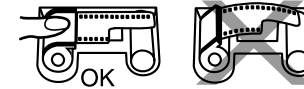

- 4. Close the back cover.**

- The camera automatically advances the film to the first frame. 1 will appear in the frame counter.
- The ISO is displayed in the data panel for 5 seconds after loading.

-  blinks in the frame counter and the shutter locks when the film is loaded incorrectly. Open the back cover and repeat steps 2 – 4.

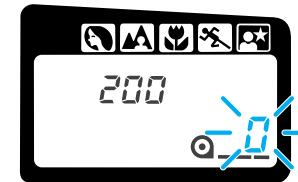

If film is loaded with the power off...

The film's ISO and  appear in the data panel for approx. five seconds to indicate successful loading, then the camera shuts down.

- If the film did not load,  will blink in the data panel before the camera shuts down. Reload the film.

## HANDLING THE CAMERA

### Holding the Camera

Grip the camera firmly with your right hand, while supporting the lens with your left. Keep your elbows at your side and your feet shoulder-width apart to hold the camera steady. Keep the camera strap around your neck or wrist in the event you accidentally drop the camera.

- Do not touch the end of the lens barrel while taking a picture.
- Use a tripod when using slow shutter speeds or a telephoto lens.



### Pressing the Shutter-Release Button

Press the shutter-release button partway down to activate the camera's autofocus and auto-exposure systems.

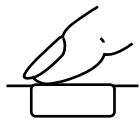
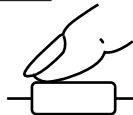

Gently press the shutter-release button all the way down to take the picture.

## EYE-START

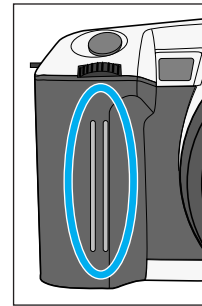

### Grip Sensor

- Autofocus and exposure systems shut down approx. five seconds after eye or grip sensor contact is broken.
- Infrared absorbing sunglasses or gloves may affect the operation of eye-start.

Eye-start automatically activates the camera's focus and exposure systems as you bring the camera to your eye. Sliding the main and eye-start switches to the ON position activates the grip sensor and data panel. Touching the grip sensor activates the eyepiece sensor located near the viewfinder. When an object is detected near the viewfinder, the camera's systems are activated to set the focus and exposure as you frame your subject.

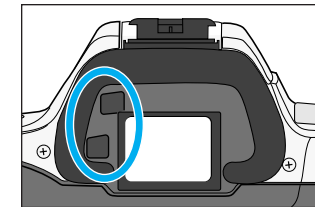

### Eyepiece Sensor

**Press the shutter-release button partway down to activate the camera when eye-start is off.**

## TAKING PICTURES IN FULL-AUTO

# FULLY-AUTOMATIC OPERATION

Full-Auto is the camera's standard operating mode and is suited for use in almost any situation. When selected, the camera sets the focus and exposure automatically and fires the built-in flash when necessary.



Use Full-Auto when you are just starting out or when shooting under conditions that would require you to constantly adjust the focus and/or exposure.

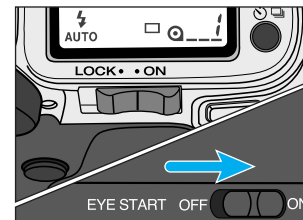

1. Slide the main and eye-start switches to ON.

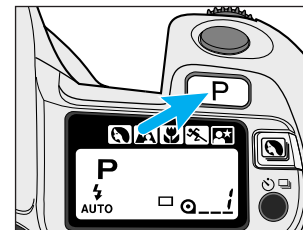

2. Press the program-reset button to set the camera to Full-Auto.
  - The camera will return to its default settings (p83).

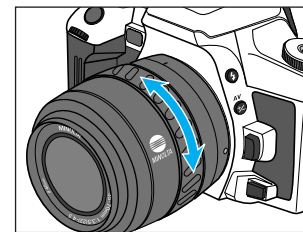

3. If using a zoom lens, rotate the lens' zooming ring to frame the subject as desired.



4. Center your subject in the focus frame [ ].
  - ● or (●) will appear in the viewfinder when focus is confirmed.
  - If ⚡ appears in the viewfinder, press the shutter-release button partway down to pop-up the built-in flash. ⚡ will disappear, then reappear when the flash is charged.

*Continued on next page.*

## TAKING PICTURES IN FULL-AUTO

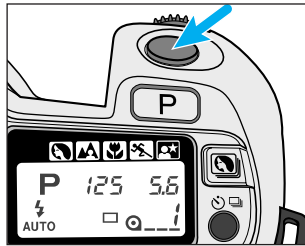

### 5. Press the shutter-release button all the way down to take the picture.

- In low-light conditions, the AF illuminator (p55) will fire to determine focus distance.
- Use focus hold (p24) if your subject is outside the focus frame.

## Focus Signals

The following signals appear in the viewfinder to indicate the focus status when focus is activated.



	<b>Focus is confirmed</b>
	Continuous autofocus – <b>Focus is confirmed</b>
	Continuous autofocus – <b>Lens focusing</b> Shutter is locked
	<b>Focus cannot be confirmed</b> – Shutter is locked. Subject is too close or is one of the special focus situations described on page 23.

## SPECIAL FOCUS SITUATIONS

The camera may not be able to focus in situations like those described below. When the focus lamp blinks, use focus hold (p24) or manual focus (p54). See page 22 for an explanation of the focus signals.

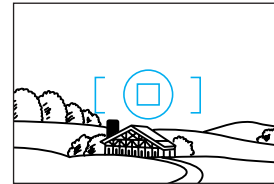

If the subject within the focus frame is very bright, or low in contrast.

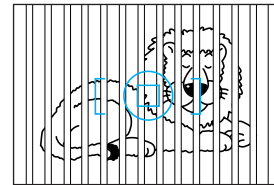

If two subjects at different distances overlap in the focus frame.

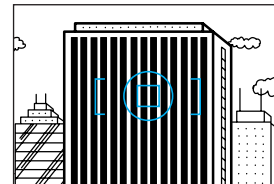

If a subject composed of alternating light and dark lines completely fills the focus frame.

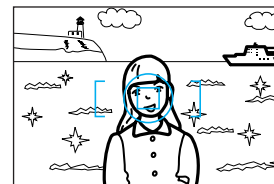

If your subject is near a very bright object or area.

## FOCUS HOLD

Use focus hold when your subject is outside the focus frame or when autofocus is difficult to confirm.



*Focus hold cannot be used for moving subjects.*

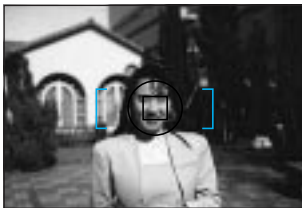

1. **Center your subject in the focus frame, then press the shutter-release button partway down.**

- ● appears in the viewfinder when the focus is confirmed.
- Focus hold also locks the exposure settings.

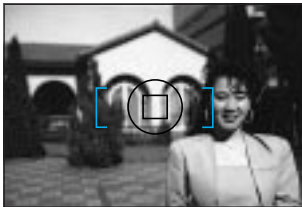

2. **Continue to hold the shutter-release button partway down while you compose your picture.**

3. **Press the shutter-release button the rest of the way down to take the picture.**

- Remove your finger from the shutter-release button to cancel focus hold.

## USING THE BUILT-IN FLASH

In Full-Auto mode (P), the built-in flash pops-up automatically when the shutter-release button is pressed partway down. Once the flash is up, it will fire when necessary.

- The shutter will not release until the flash is charged.
- Select flash cancel (ⓧ) when you don't want the flash to fire.
- Pressing the program-reset button (P) resets the flash to autoflash mode.

*Do not use the built-in flash with focal lengths shorter than 28mm. The built-in flash cannot cover focal lengths wider than 28mm.*

**Custom Function 5 (p79) lets you cancel the built-in flash's auto pop-up feature. When selected, the flash-mode button must be pressed to raise the built-in flash.**



### Lens Shadowing

Lens shadowing occurs when the lens or lens hood blocks part of the output from the built-in flash. Lens shadowing appears as semi-circular shaded area at the bottom (horizontal) or side (vertical) of your image.

- Remove the lens hood before using the built-in flash.
- Lens shadowing may occur with the following lenses at shorter focal lengths.
  - AF Zoom 28-70mm f/2.8G
  - AF Zoom 17-35mm f/3.5G
  - AF Zoom 28-135mm f/4.0-4.5
  - AF Zoom 28-85mm f/3.5-4.5
- The built-in flash can not be used with the following lenses:
  - AF 300mm f/2.8 (APO tele)
  - AF 600mm f/4.0 (APO tele)

## USING THE BUILT-IN FLASH

### Flash Signals

	<b>Eye-start ON</b> – Flash will fire.  disappears when the shutter-release button is pressed partway down, then reappears when the flash is charged.
	<b>Eye-start OFF</b> – Flash is charged.
	Previous exposure was correct.

### Flash Range

The range of the built-in flash depends on the speed of the film and the selected aperture. Make sure your subject is within the flash range specified in the table below.

*Make sure you are at least 1m (3.3 ft.) from your subject when using the built-in flash.*

Aperture	ISO 100	ISO 200	ISO 400
<b>f/2.8</b>	1.0 ~ 4.3m (3.3 ~ 14.1 ft.)	1.0 ~ 6.1m (3.3 ~ 20. ft.)	1.0 ~ 8.6m (3.3 ~ 28.2 ft.)
<b>f/3.5</b>	1.0 ~ 3.4m (3.3 ~ 11.2 ft.)	1.0 ~ 4.8m (3.3 ~ 15.7 ft.)	1.0 ~ 6.8m (3.3 ~ 22.3 ft.)
<b>f/4.0</b>	1.0 ~ 3.0m (3.3 ~ 9.8 ft.)	1.0 ~ 4.2m (3.3 ~ 13.8 ft.)	1.0 ~ 6.0m (3.3 ~ 19.7 ft.)
<b>f/5.6</b>	1.0 ~ 2.1m (3.3 ~ 6.9 ft.)	1.0 ~ 3.0m (3.3 ~ 9.8 ft.)	1.0 ~ 4.3m (3.3 ~ 14.1 ft.)

## USING THE BUILT-IN FLASH

### Fill Flash

Use fill flash when taking pictures under fluorescent lighting or to eliminate harsh shadows. When set, the flash will fire every time a picture is taken. The TTL automatic flash metering system will ensure correct exposure.

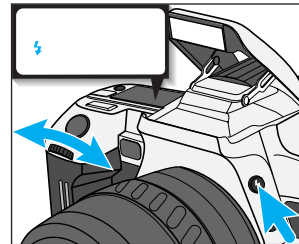



**Press the flash-mode button and turn the control dial until  appears in the data panel.**

- Make sure your subject is within the flash range specified in the table on page 26.
- Press the flash-mode button and turn the control dial until  appears to return to autoflash mode.
- For quick shots, hold the flash-mode button down when pressing the shutter-release button to fire the fill flash.

### Flash Cancel

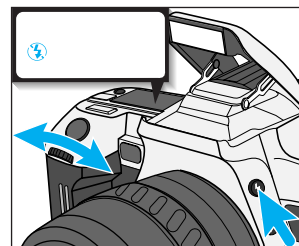
Use flash cancel when photographing twilight scenes or to capture the ambiance of existing light.



**Press the flash-mode button and turn the control dial until  appears in the data panel.**

- Press the flash-mode button and turn the control dial until  appears to return to autoflash mode.

*The shutter speed may be slow.  
Use of a tripod is recommended.*

## USING THE BUILT-IN FLASH

### Red-Eye Reduction

Light reflecting from your subject's eyes may produce the effect known as red-eye. Use the built-in flash's red-eye-reduction mode to produce more natural looking photographs by reducing the red-eye effect.

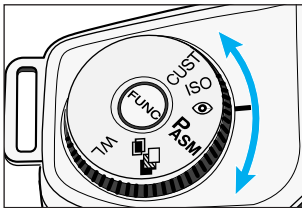

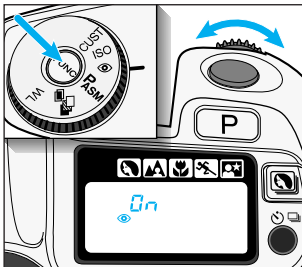

1. Turn the function dial to .



2. Press the function button and turn the control dial until  and **ON** appear in the data panel.
  - Warn your subject that the flash will fire a few short flash bursts just before the picture is taken.

### Cancelling Red-eye Reduction





- Turn the function dial to , then press the function button and turn the control dial until  and **OFF** appear in the data panel.

## REWINDING THE FILM

### Automatic Rewind

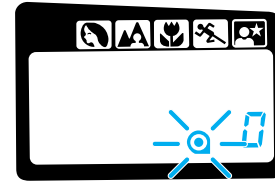
After you have exposed the last frame, the camera will automatically rewind the film. When the film is completely rewound, the motor will stop and  will blink in the data panel indicating it is safe to open the back of the camera.



1. Wait until the film is completely rewound.
  -  will appear and  will blink in the data panel.

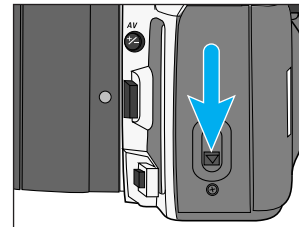

2. Slide the back-cover release down to open the back cover.
3. Remove the film, then close the back cover.

### Manual Rewind

Use manual rewind to rewind the film before the current roll is finished.

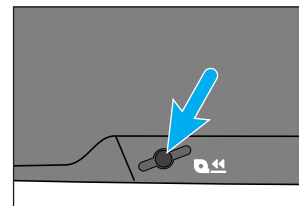

1. Press the manual-rewind button.
2. Follow steps 1-3 from Automatic Rewind.



## SUBJECT PROGRAM SELECTION

### LEVEL II

Now that you are comfortable with the operation of the camera, take more control of the creative process by telling the camera what kind of picture you want to take.

The subject program modes let you take more control without leaving the program exposure mode. In each of the subject program modes, the camera will automatically set the best possible shutter speed and aperture for the type of picture you are taking.

This section also lets you explore the use of the Self-timer and Continuous Advance modes.

Subject Program Selection	Page
Portrait Mode	31
Landscape Mode	32
Close-Up Mode	33
Sports Mode	34
Night Portrait Mode	35
Photographing Night Scenes	36

Drive Mode	Page
Self-Timer	37
Continuous Advance	38

Each of these functions can be explored independently after Level I has been mastered.

- Press the program-reset button to return the camera to Full-Auto operation.

### Portrait Mode

Portraits have the greatest impact when a shallow depth-of-field\* is used to separate the subject from the background. In Portrait mode, the necessary settings are made automatically, leaving you free to capture the perfect expression.



\* Depth-of-field is the area in front of and behind the point you focused on that appears sharp (p42).

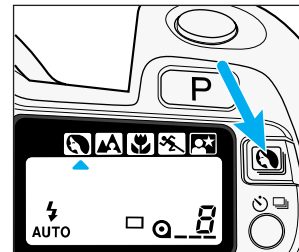

Press the subject-program button until the subject-program pointer is under .

### Tips

- For best results use a mid-telephoto lens with a large aperture.
- Use fill flash (p27) when your subject is backlit or has strong shadows across the face.
- Lock focus on your subject's eyes and be ready to capture the perfect expression.

## SUBJECT PROGRAM SELECTION

### Landscape Mode

Landscape photography requires a large depth-of-field to make sure everything is in focus. In Landscape mode, the camera is set to obtain the greatest depth-of-field possible, while maintaining a shutter speed fast enough to prevent blur due to camera shake.

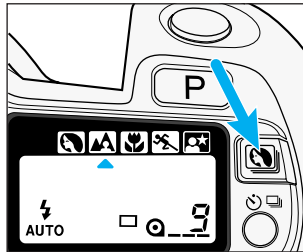

Press the subject-program button until the subject-program pointer is under .

#### Tips

- For best results zoom to a wide view or use a wide angle lens and include a foreground subject or detail to create a feeling of depth in the picture.
- Use flash when a subject in the foreground is backlit or has strong shadows across the face. If there is no subject in the foreground, do not use flash.
- Use a tripod, especially at slower shutter speeds.

## SUBJECT PROGRAM SELECTION

### Close-Up Mode

Set Close-Up mode when photographing small objects like flowers or jewelry. In Close-Up mode, the camera automatically sets the best possible aperture and shutter speed for the picture you are taking.

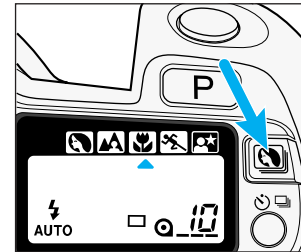

Press the subject-program button until the subject-program pointer is under .

#### Tips

- For best results use a macro lens or a macro capable zoom lens.
- Do not use the built-in flash if your subject is closer than 1.0m (3.3 ft.). The lens may block the flash, creating a shadow at the bottom of your image (lens shadowing).
- Use a tripod to reduce camera shake.

## SUBJECT PROGRAM SELECTION

### Sports Mode

Fast shutter speeds are needed to stop action. In Sports mode, the camera will set the fastest possible shutter speed and continually adjust the focus to track fast-moving subjects.

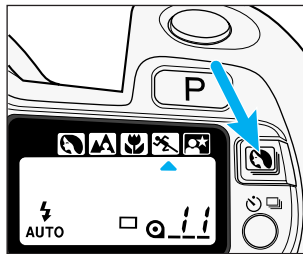

Press the subject-program button until the subject-program pointer is under .

#### Tips

- The built-in flash is only effective when your subject is within the flash range.
- Use fast film and keep the focus frame on your subject.
- Mount the camera on a tripod when using telephoto lenses.
- Use Spot AF to hold the focus in Sports mode (p53).

## SUBJECT PROGRAM SELECTION

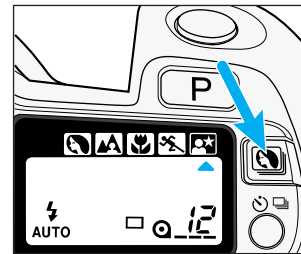

### Night Portrait Mode

Night portraits require the camera's flash exposure to be balanced with the background exposure. In Night Portrait mode, the camera sets the largest possible aperture with a longer shutter speed, allowing the background to appear in the photograph.



Press the subject-program button until the subject-program pointer is under .

#### Tips

- Set the flash to  or  when using Night Portrait mode. See pages 27 and 28.
- Use faster film and a tripod.
- Focus on the main part of your subject.
- Warn your subject not to move while the picture is taken.

## SUBJECT PROGRAM SELECTION

### Photographing Night Scenes

Cancel the flash in Night Portrait mode to photograph night scenes. The longer shutter speeds set in Night Portrait mode let you capture beautiful photographs of twilight scenes and night skylines.

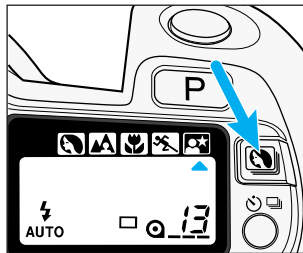

1. Press the subject-program button until the subject-program pointer is under .

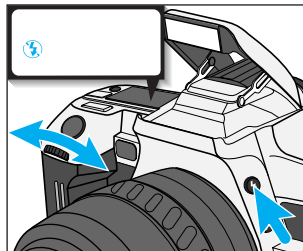

2. Press the flash-mode button and turn the control dial until  appears in the data panel.

#### Tips

- Use faster film and a tripod.
- If you are photographing a dark night scene, it may be difficult for the camera to focus, use focus hold (p24) or manual focus (p54).

## SELF-TIMER

The self-timer delays the release of the shutter for approximately 10 seconds after the shutter-release button is pressed.



1. Place the camera on a tripod, then press the self-timer button until  appears in the data panel.



2. Center your subject in the focus frame.
3. Press the shutter-release button all the way down to start the timer.

- The self-timer indicator on the front of the camera will blink, then glow just before the shutter releases.

- Self-timer mode is cancelled after the shutter is released.
- Do not press the shutter-release button while standing in front of the camera.
- Attach the eyepiece cap if there is a bright light source behind the camera (p50).

Press the self-timer button or slide the main switch to LOCK to cancel the self-timer before the shutter releases.

## CONTINUOUS-ADVANCE MODE

In this mode, the camera continues to release the shutter and advance the film as long as the shutter-release button is held down.

- AF Zoom xi and Power zoom lenses cannot be zoomed when continuous-advance mode is selected.

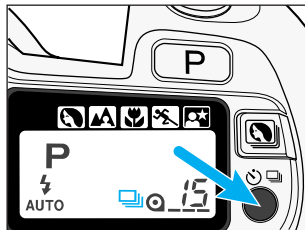

**1. Press the drive-mode button until  appears in the data panel.**

**2. Press the shutter-release button down and hold.**

- When taking flash pictures, the shutter will release after the flash is charged.
- When the subject is moving, the shutter will release after the camera focuses on the subject.
- To return to single frame mode, press the drive mode button until  appears in the data panel.

## LEVEL III

In this section you take full creative control of your camera. Depending on the selected exposure mode, you will control the aperture, shutter speed, or both when capturing your image.

In the previous sections, only the Program (P) exposure mode has been explored. Here you will learn to use the Aperture Priority (A), Shutter Priority (S), and Manual (M) exposure modes. Select A-mode to control the depth-of-field in your images. Set S-mode to control the way moving subjects appear in your images. Set M-mode when you want full control over all the exposure functions.

A-Mode	Manually select aperture	40
S-Mode	Manually select shutter speed	43
M-Mode	Manually select the shutter speed and the aperture	46

- Each exposure mode can be explored independently.

## A-MODE – APERTURE PRIORITY

In A-mode, you select the aperture and the camera automatically sets the shutter speed required for proper exposure. Set the camera to A-mode when you want to control the range of sharpness (depth-of-field) in an image. Refer to Aperture Control on page 42.

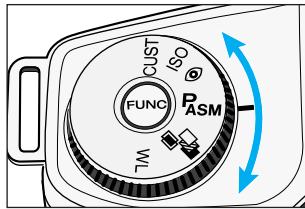

1. Turn the function dial to **P<sub>ASM</sub>**.

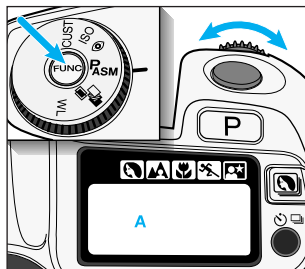

2. Press the function button and turn the control dial until **A** appears in the data panel.

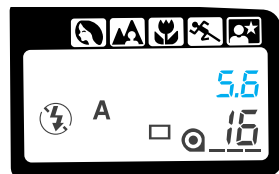

3. Turn the control dial to select the aperture.

If 4000 or 30 s blinks in the data panel, the required setting is beyond the camera's shutter speed range. Turn the control dial until the blinking stops.

## A-MODE – APERTURE PRIORITY

### A-Mode Flash

When the built-in flash is up or an attached accessory flash is on, it will fire each time a picture is taken. The camera's TTL automatic flash metering system will ensure proper exposure.

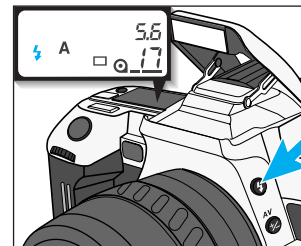

Press the flash-mode button to pop-up the built-in flash.

- ⚡ will appear in the data panel.
- The shutter speed is automatically set to 1/125 or slower.
- A smaller aperture (larger f-number) will result in a shorter flash range. Refer to Flash Range (p26) to determine the range of the built-in flash at the selected aperture.

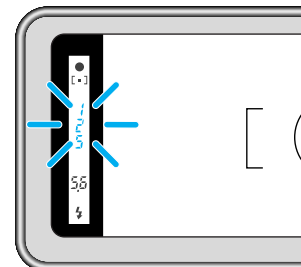

If 125 blinks in the viewfinder and the data panel, the light level is too bright for the selected aperture. Turn the control dial until the blinking stops or cancel the flash.

### Cancelling the Flash

Push the built-in flash down or turn the accessory flash off.

- ⚡ will be displayed in the data panel.

## A-MODE – APERTURE PRIORITY

### Aperture Control



**Large Aperture**  
(small f-number)



**Small Aperture**  
(large f-number)

The size of the aperture (lens opening) determines the depth-of-field in the final image as well as the intensity of the light falling on the film. Depth-of-field is the range in front of and behind the focus point that appears sharp in the final image. In the viewfinder, only the plane the camera is focused on will appear sharp. The photographed image however, will have a depth-of-field corresponding to the selected aperture.

Large apertures (small numbers) limit the depth-of-field to a narrow range in front of and behind the point of focus. Set a larger aperture when photographing portraits to make your subject stand out from the background.

Small apertures (large numbers) provide greater depth-of-field. Set a small aperture when photographing landscapes to ensure your entire scene is sharp.

- Usable apertures will depend on the aperture range of the lens you are using.

## S-MODE – SHUTTER PRIORITY

In S-mode, you select the shutter speed and the camera automatically sets the aperture required for proper exposure. Use S-mode when you want to control the blur caused by subject movement.

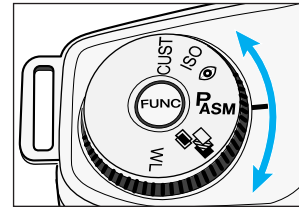

1. Turn the function dial to  $P_{ASM}$ .

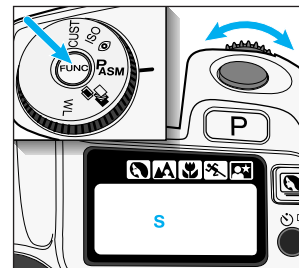

2. Press the function button and turn the control dial until **S** appears in the data panel.



3. Turn the control dial to select the shutter speed.

- The number 60, or 125, displayed in the data panel stands for 1/60th or 1/125th of a second.
- The seconds indicator appears in the viewfinder and data panel if the shutter speed is one second or longer.

If the aperture display in the data panel blinks, the required setting is outside the aperture range of the lens. Turn the control dial until the blinking stops.

## S-MODE – SHUTTER PRIORITY

### S-Mode Flash

When the built-in flash is up or an attached accessory flash is on, it will fire each time a picture is taken. Flash exposure is controlled by the camera's TTL automatic flash metering system.

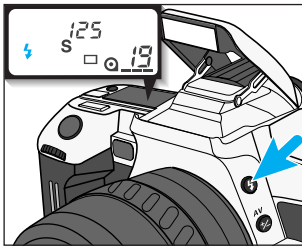

**1. Press the flash-mode button to pop-up the built-in flash.**

- ⚡ will appear in the data panel.

**2. Turn the control dial to select any shutter speed up to 1/125th of a second.**

- The camera automatically sets the aperture for the selected shutter speed.

### Cancelling the Flash

**Push the built-in flash down or turn the accessory flash off.**

- ⚡ will be displayed in the data panel.

## S-MODE – SHUTTER PRIORITY

### Shutter Control



**Fast Shutter Speed**



**Slow Shutter Speed**

In addition to controlling the duration of the exposure, shutter speed determines how moving subjects will appear in the final image. Depending on the speed of your subject, slow shutter speeds will make a moving subject appear to flow, creating a feeling of motion. In addition to stopping action, fast shutter speeds can help prevent blur caused by camera movement during exposure, known as camera shake.

- Use a fast shutter speed to stop the motion of your subject.
- Use a slow shutter speed to blur the motion of your subject.



## M-MODE – MANUAL

M-mode gives you full control of the exposure. The camera's meter index displays how your settings compare to the exposure determined by the camera's metering system.

1. Turn the function dial to **P<sub>ASM</sub>**.

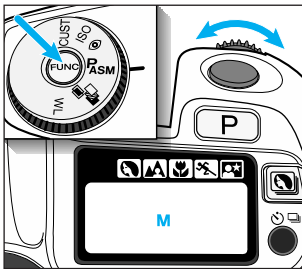

2. Press the function button and turn the control dial until **M** appears in the data panel.

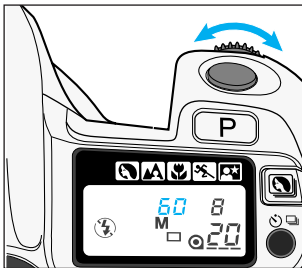

3. Turn the control dial to select the shutter speed.

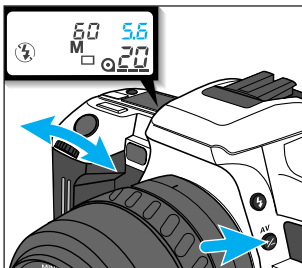

4. Press the exposure-compensation button and turn the control dial to select the aperture.

## M-MODE – MANUAL

### Metering in Manual Mode

In manual mode, the meter index in the viewfinder and the data panel indicates how your exposure compares with the camera's meter reading.

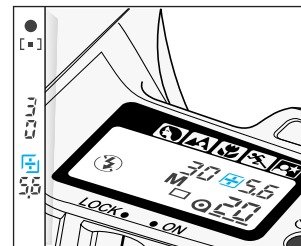

- The exposure will over-expose your subject.

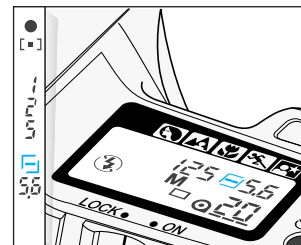

- The exposure will under-expose your subject.

*If an exposure compensation indicator does not appear, your settings agree with the exposure determined by the camera.*

## Free Manuals Download Website

<http://myh66.com>

<http://usermanuals.us>

<http://www.somanuals.com>

<http://www.4manuals.cc>

<http://www.manual-lib.com>

<http://www.404manual.com>

<http://www.luxmanual.com>

<http://aubethermostatmanual.com>

Golf course search by state

<http://golfingnear.com>

Email search by domain

<http://emailbydomain.com>

Auto manuals search

<http://auto.somanuals.com>

TV manuals search

<http://tv.somanuals.com>