

MINOLTA

The essentials of imaging

www.minolta.com

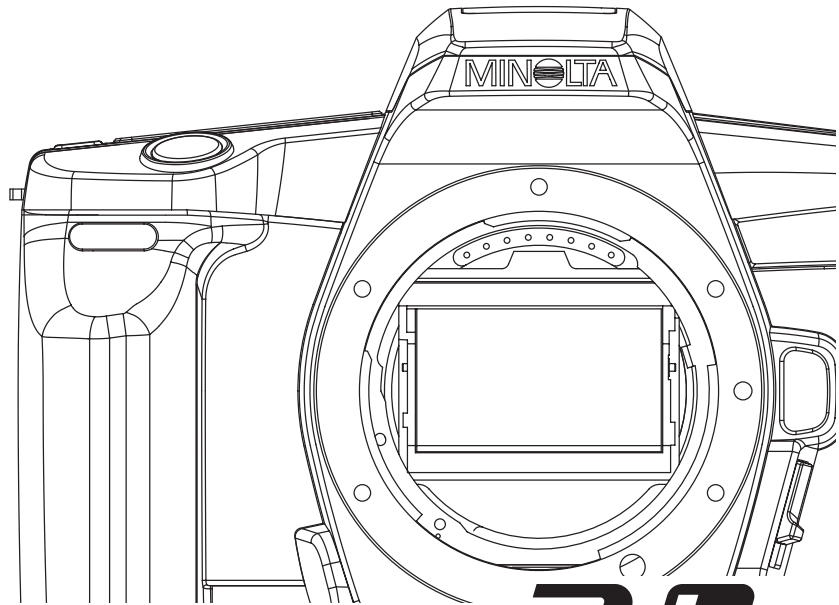

DYNAX 30 **MAXXUM 3**

E INSTRUCTION MANUAL

TABLE OF CONTENTS

FOR PROPER AND SAFE USE	5
NAMES OF PARTS	8
Body	8
Data Panel.....	10
Viewfinder	11
QUICK OPERATION	12
GETTING STARTED	14
BATTERIES	14
Installing the Batteries.....	14
Battery Condition Indicators	15
DATE AND TIME SETTING - For Owners of the Quartz-date Model	16
Names of Parts for Date and Time Setting	16
Setting the Date and Time	17
Selecting the Imprinting Format	18
Changing the Date Format.....	19
Storing the Date and Time Setting When Changing Batteries.....	19
STRAP.....	20
LENS	22
Attaching the Lens	22
Removing the Lens	22
FILM	23
Loading the Film.....	23
Rewinding the Film.....	26
Manual Rewind.....	26
BASIC OPERATION.....	27
HANDLING THE CAMERA	27
Pressing the Shutter-release Button	27
Holding the Camera	27
TAKING PICTURES	28
Focus Signals.....	29
FOCUS LOCK	30
SPECIAL FOCUS SITUATIONS	31
AF ILLUMINATOR	31
BUILT-IN FLASH.....	32
Changing the Flash Mode.....	32
Flash Range	32
Flash Signals.....	33
Lens Shadowing.....	33

Autoflash	34
Autoflash with Red-eye Reduction	34
Fill Flash	35
Fill Flash with Red-eye Reduction	35
Flash Cancel	36
Setting the Default Autoflash Mode	36
SUBJECT PROGRAM	37
Subject Program Selection	37
Portrait	38
Landscape	38
Close-up	39
Sports	39
Night Portrait	40
Night Scene	40
DRIVE MODES	41
Self-timer	41
Continuous Advance	43
Remote-control Function - For Owners of the Quartz-date Model	44
Focus Lock in Remote Control Mode	45
ADVANCED OPERATION	46
SPOT FOCUS	46
MANUAL FOCUS	47
FLASH	48
Program Flash	48
Flash Metering	49
Flash Notes	49
WIRELESS / REMOTE FLASH	50
Setting Wireless / Remote Flash Mode	51
Taking Pictures in Wireless / Remote Flash Mode	52
Canceling Wireless / Remote Flash Mode	53
APPENDIX	54
USEFUL INFORMATION	54
Reset Default	54
Canceling Shutter-release Lock	54
Canceling the AF Illuminator	55
ACCESSORY INFORMATION	56
TROUBLESHOOTING	58
CARE AND STORAGE	60
SPECIFICATIONS	62

Thank you for purchasing this camera. Please take time to read this manual so that you can enjoy all the features of your new camera.

This product is designed to work with accessories manufactured and distributed by Minolta. Using accessories or equipment not endorsed by Minolta may result in unsatisfactory performance or damage to the product and its accessories.

This device complies with Part 15 of the FCC Rules. Operation is subject to the following two conditions: (1) This device may not cause harmful interference, and (2) this device must accept any interference received, including interference that may cause undesired operation. Changes or modifications not approved by the party responsible for compliance could void the user's authority to operate the equipment. This equipment has been tested and found to comply with the limits for a Class B digital device, pursuant to Part 15 of the FCC Rules. These limits are designed to provide reasonable protection against harmful interference in a residential installation. This equipment generates, uses and can radiate radio frequency energy and, if not installed and used in accordance with the instructions, may cause harmful interference to radio communications. However, there is no guarantee that interference will not occur in a particular installation. If this equipment does cause harmful interference to radio or television reception, which can be determined by turning the equipment off and on, the user is encouraged to try to correct the interference by one or more of the following measures:

- Reorient or relocate the receiving antenna.
- Increase the separation between the equipment and the receiver.
- Connect the equipment to an outlet on a circuit different from that to which the receiver is connected.
- Consult the dealer or an experienced radio/TV technician for help.

This Class B digital apparatus complies with Canadian ICES-003.



This mark on the bottom of your camera is there to inform you that this camera meets the requirements of the EU (European Union) concerning interference causing equipment regulations. CE stands for Conformité Européenne (European Conformity).

FOR PROPER AND SAFE USE

Read and understand all warnings and cautions before using this product.

WARNING

Using batteries improperly can cause them to leak harmful solutions, overheat, or explode which may damage property or cause personal injury. Do not ignore the following warnings.

- Only use the batteries specified in this instruction manual.
 - Do not install the batteries with the polarity (+/-) reversed.
 - Do not use batteries which show wear or damage.
 - Do not expose batteries to fire, high temperatures, water, or moisture.
 - Do not attempt to recharge, short, or disassemble batteries.
 - Do not store batteries near or in metallic products.
 - Do not mix batteries of different types, brands, or ages.
 - Do not use leaking batteries. If fluid from the batteries enters your eye, immediately rinse the eye with plenty of fresh water and contact a doctor. If fluid from the batteries makes contact with your skin or clothing, wash the area thoroughly with water.
 - Tape over lithium battery contacts to avoid short-circuiting during disposal; always follow local regulations for battery disposal.
-
- Do not disassemble this product. Electric shock may cause injury if a high voltage circuit inside the product is touched.
 - Immediately remove the batteries and discontinue use if the camera is dropped or subjected to an impact in which the interior, especially the flash unit, is exposed. The flash has a high voltage circuit which may cause an electric shock resulting in injury. The continued use of a damaged product or part may cause injuries.
 - Keep batteries or small parts that could be swallowed away from infants. Contact a doctor immediately if an object is swallowed.

FOR PROPER AND SAFE USE

WARNING

- Store this product out of reach of children. Be careful when around children not to harm them with the product or parts.
- Do not fire the flash directly into the eyes. It may damage eyesight.
- Do not fire the flash at vehicle operators. It may cause a distraction or temporary blindness which may lead to an accident.
- Do not look at the sun or strong light sources directly through the viewfinder or lens. It may damage your eyesight or cause blindness.
- Do not expose this product to liquids or operate this product with wet hands. If liquid enters the product, immediately remove the batteries and discontinue use. The continued use of a product exposed to liquids may cause damage or injury through fire or electric shock.
- Do not use the product near inflammable gases or liquids such as gasoline, benzine, or paint thinner. Do not use inflammable products such as alcohol, benzine, or paint thinner to clean the product. The use of inflammable cleaners and solvents may cause an explosion or fire.
- If the product emits a strange odor, heat, or smoke, discontinue use. Immediately remove the batteries taking care not to burn yourself. The continued use of a damaged product or part may cause injuries.
- Take the product to a Minolta Service Facility when repairs are required.

CAUTION

- Do not point the product directly at the sun. If sunlight is focused on an inflammable surface, a fire may result. Replace the lens cap when the product is not in use.
- Do not use or store the product in a hot or humid environment such as the glove compartment or trunk of a car. It may damage the product and batteries which may result in burns or injuries caused by heat, fire, explosion, or leaking battery fluid.
- If batteries are leaking, discontinue use of the product.
- Do not fire the flash while it is in contact with people or objects. The flash unit discharges a large amount of energy which may cause burns.

NAMES OF PARTS

Body

For information on specific parts, refer to the page numbers shown in parenthesis.

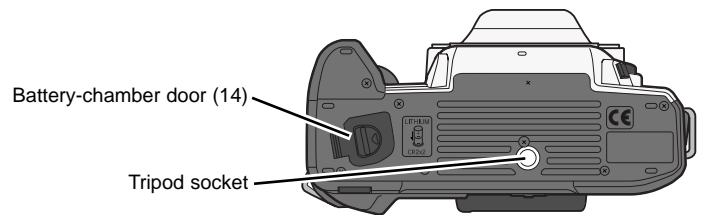
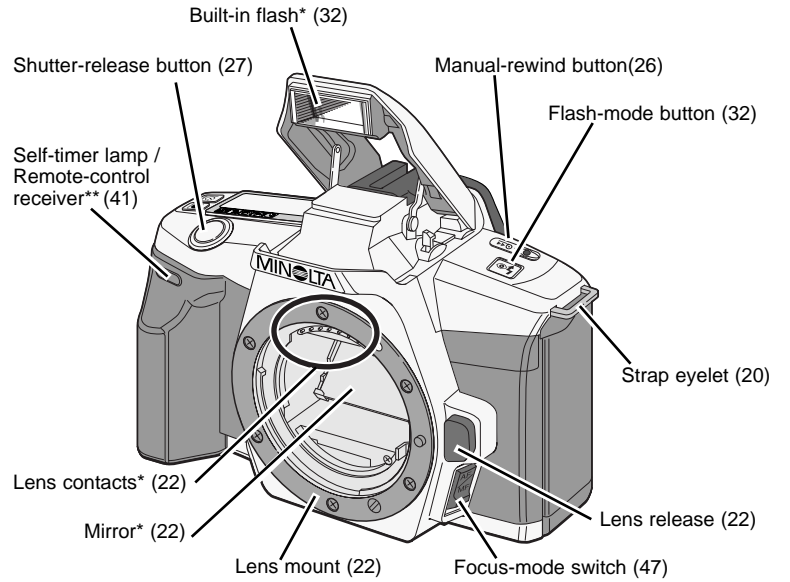

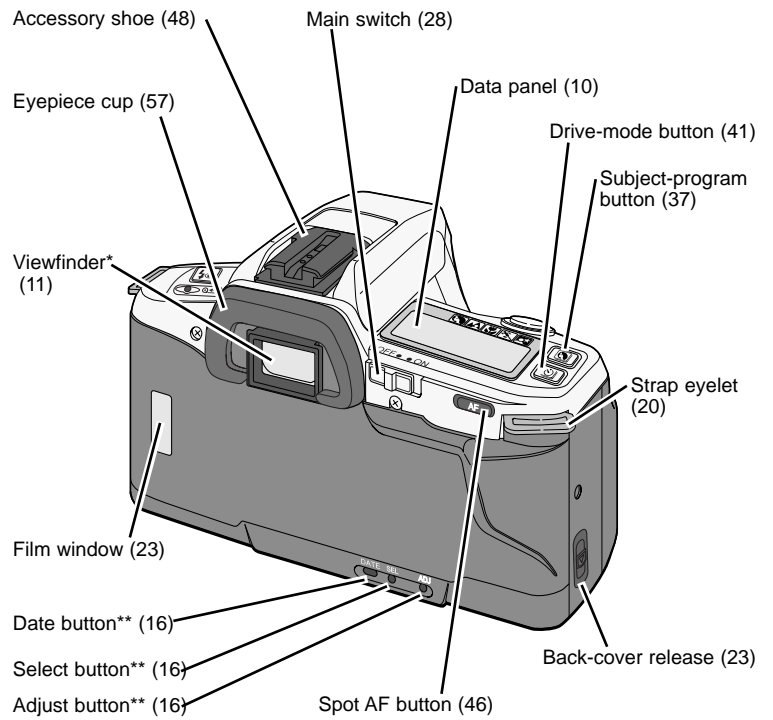

* This camera is a sophisticated optical instrument. Care should be taken to keep these surfaces clean. Please read the care and storage instructions in the back of this manual (p. 60).

** Quartz-date model only. The quartz-date model is equipped with remote-control function.

NAMES OF PARTS

Data Panel

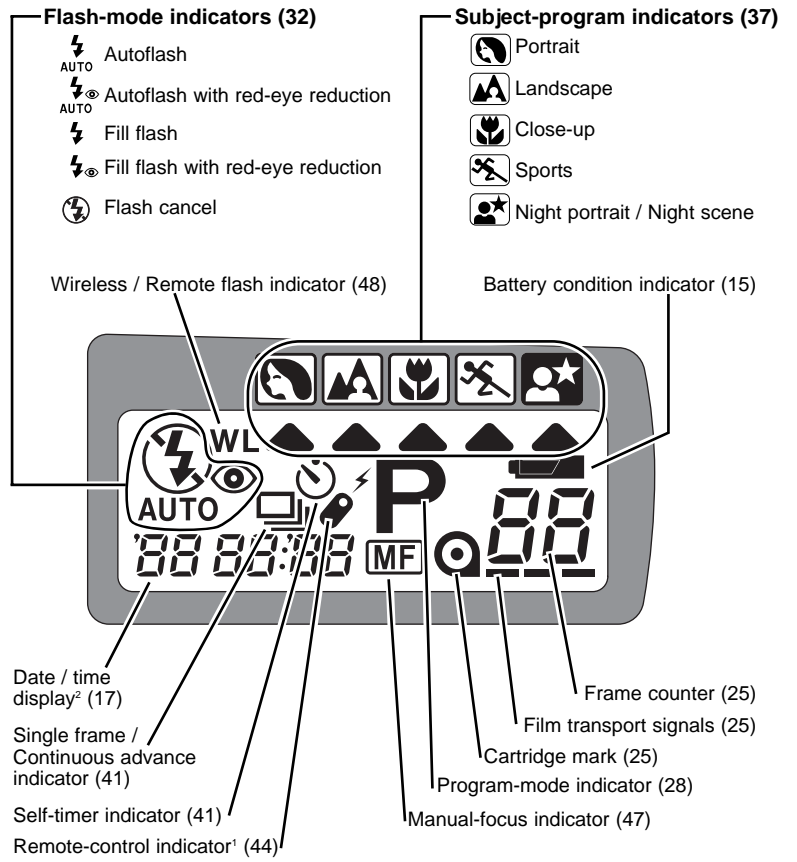

1 Available on the remote-control model only.

2 Available on the quartz-date model only.

The quartz-date model is equipped with remote-control function.

10

Viewfinder

Spot-focus area (46) Wide focus frame (28)

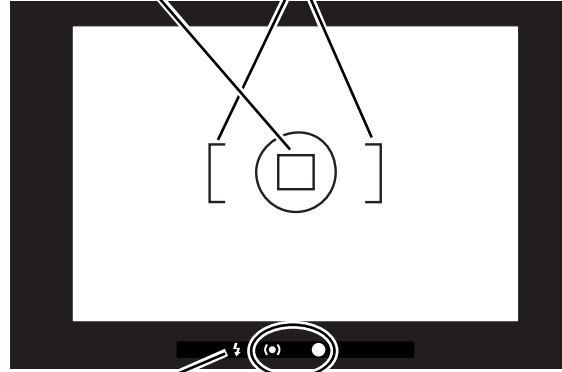

Flash signals (33)

Focus signals (29)

Focus signals

● Steady	Focus is confirmed and locked.
◐ Steady	Focus is confirmed with a moving subject. The camera continues to focus while the shutter-release button is pressed partway down.
● Blinks	Focus cannot be confirmed. <ul style="list-style-type: none"> • The shutter is locked (p. 31).

Flash signals

⚡ Steady	Flash is charged and will fire when the shutter-release button is pressed.
⚡ Blinks	Flash output was sufficient to provides correct exposure.

- When the flash signal does not blink after taking the picture, the subject was not within the flash range. Please check the flash range (p. 32).

QUICK OPERATION

1. Insert the batteries (p. 14).

- This camera uses two CR2 lithium batteries.

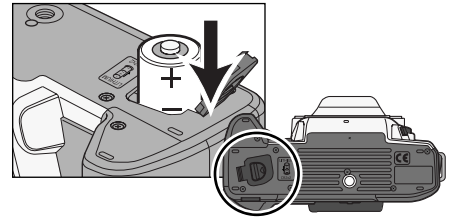

2. If the camera is the quartz date model, set the date and time, and imprinting format (p. 16).

- The clock and calendar are powered by the camera's batteries.

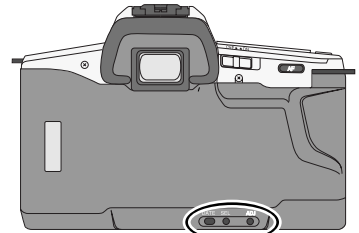

3. Attach the lens (p. 22).

- Align the red mounting index on the lens with the one on the camera. Carefully insert the lens into the mount and turn it clockwise until it clicks into the locked position.

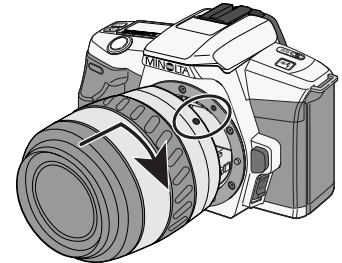

4. Slide the main switch to the on position.

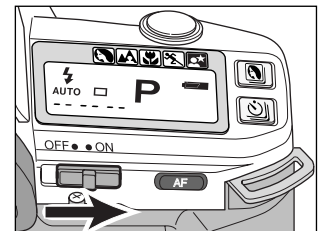

5. Open the back cover and load the film (p. 23).

- Align the film tip with the red mark, then close the back cover.

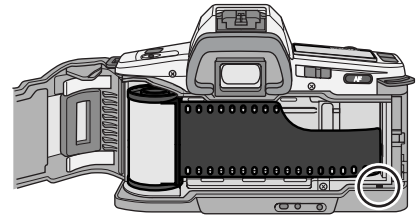

6. Center the subject in the wide focus frame. If using a zoom lens, rotate the zooming ring to frame the subject (p. 28).

- The camera will focus and set exposure automatically when the shutter release button is pressed partway down.



7. When the focus signal appears in the viewfinder, press the shutter-release button all the way down to take the picture (p. 28).

- Use focus lock if your subject is off-center and outside the focus frame (p.30).

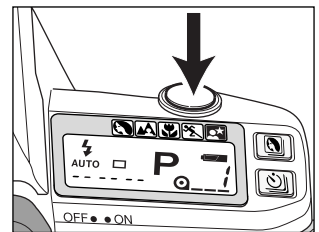

BATTERIES

GETTING STARTED

Installing the Batteries

The camera uses two 3V CR2 lithium batteries to supply power for all camera operations.

1. Slide the battery-chamber release as shown, and open the door.

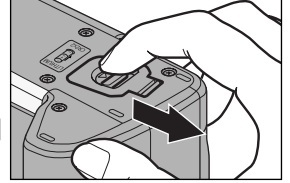
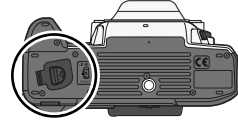

2. Insert the batteries with the polarities as indicated by the illustration next to the battery chamber.

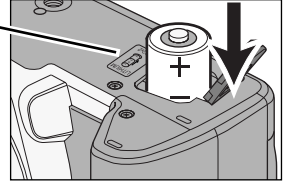

3. Close the battery-chamber door and push until it clicks into place.

- Setting the camera down with the battery-chamber door open may damage the camera.
- Read the for proper and safe use section (p. 5) before using batteries.

Battery Condition Indicators

Slide the main switch to on position.

- A battery indicator appears on the data panel indicating the power status of the batteries.

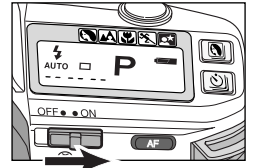

Full-battery indicator.

- Power is sufficient for all camera operations.



Half-battery indicator blinks.

- Power is low. All functions are operational, but the batteries should be replaced soon. Flash recycling time may be slow.



Half-battery indicator blinks and no other indicators appear on the data panel.

- Power is insufficient for camera operation and the shutter is locked. Replace the batteries.

- If the data panel is blank, the batteries may be dead or installed incorrectly.
- Occasionally, the battery-condition indicator will give a false low-battery-power warning, even though there is enough power capacity. Turn the camera on and off a few times to reset the display.

DATE AND TIME SETTING - FOR OWNERS OF THE QUARTZ-DATE MODEL

GETTING STARTED

The quartz-date function records the date or time in the lower-left corner of the photograph. The quartz date back has an automatic calendar through the year 2039.

- Imprinted data may be difficult to read if the lower-left corner of the photograph is bright or non-uniform.
- Only use the data back in temperatures between 0° to 50°C (32° to 122°F).
- Since the date is recorded when the film is advanced to the next frame, sometimes the last frame of the roll will not have the date printed on it.

The clock and calendar are powered by the camera's batteries. If the clock and calendar have not been set, "-- --" blinks on the date / time displays of the data panel when the camera is on.

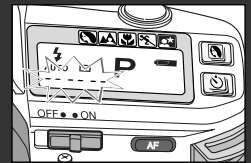

Before the initial use of the camera, or after changing the batteries, the date and time should be set. The imprinting format should be selected at this time.

To store the date and time in the camera's internal memory before changing batteries, see page 19.

Names of Parts for Date and Time Setting

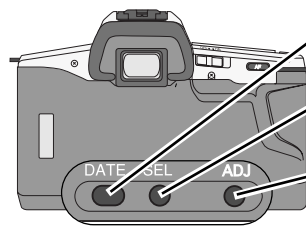

Date button

Use this button to change the imprinting format.

Select button

Use this button to select the item to be changed.

Adjust button

Use this button to change the date and time values.

- Gently press these buttons using a blunt object like a pen. A sharp object may cause damage.

Setting the Date and Time

1. Slide the main switch to the on position.

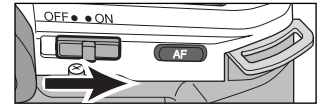

The following example changes the date and time from the default setting of 2003, January 1, 0:00 to 2004, March 24, 15:45.

2. Press the select button to select the year.

- '03 will blink indicating 2003.
- The item will cycle as follows.

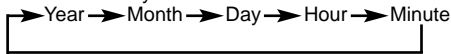

3. Press the adjust button to change the year.

- '04 indicates 2004.
- The item continues increasing as long as the button is held down.
- During the cycle the year jumps from '39 down to '03.



4. Press the select button to select the month.

- The month register will blink. The initial setting is January.



5. Press the adjust button to change the month value.

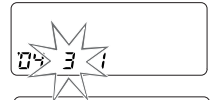

6. Press the select button to select the day.

- The day register will blink. The initial setting is 1st.



7. Press the adjust button to change the day value.

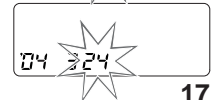

DATE AND TIME SETTING - FOR OWNERS OF THE QUARTZ-DATE MODEL

GETTING STARTED

8. Press the select button to select the hour.

- The display will be changed from date to time.
- The hour register will blink. The initial setting is 0.
- Confirm the date when adjusting the clock to a different time zone or near midnight.



9. Press the adjust button to change the hour value.

- The data back has a 24-hour clock 3pm is 15.



10. Press the select button to select the minute.

- The minute register will blink. The initial setting is 00.



11. Press the adjust button to change the minute value.



12. Press the select button to set the clock and calendar.

- The data panel will stop blinking and return to the initial display.
- Pressing the shutter-release button partway down or pressing the date button will also set the clock and calendar.
- To synchronize the camera to another clock, set the minute register to the upcoming time and press the adjust button when the other clock reaches that time.



Selecting the Imprinting Format

Press the date button to choose the date imprinting format.

- The display changes as follows:

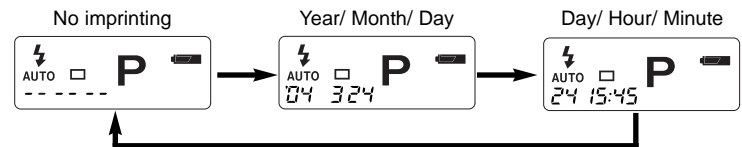

18

Changing the Date Format



Date button Select button Adjust button

1. Press and hold the select button for 3 seconds until the date on the data panel blinks.

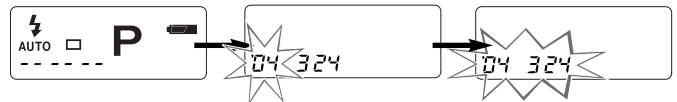

2. Press the adjust button to change the format.

- The format will change in the following sequence:

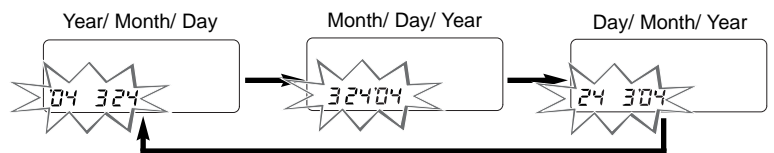

3. Press the shutter-release button partway down to set the format.

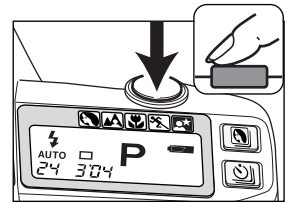

Storing the Date and Time Setting When Changing Batteries

If the date imprinting display (-- -- --) blinks after changing the batteries, the clock and calendar have been reset. To prevent this, just before changing batteries slide the main switch from off to on, and then to off again to store the date and time setting in the camera's internal memory.

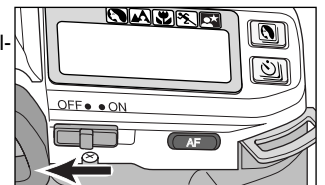

ATTACHING THE STRAP

GETTING STARTED

- 1. Confirm the eyepiece cap is attached to the strap. The strap is threaded through the cap to prevent loss.**

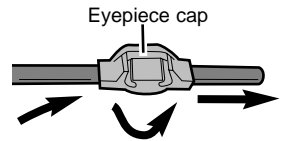

- 2. With the visible protrusions on the inside of the holder ring oriented as shown, pass the tip of the strap through the ring.**

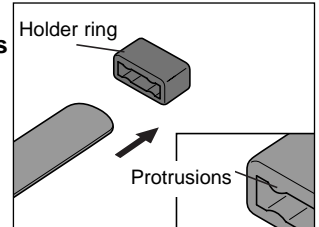

- 3. Pass the tip of the strap through the camera's strap eyelet from below.**

- Attach the strap so the tip comes between the strap and the camera.
- The eyepiece cap should be on the same side of the camera as the flash mode button.

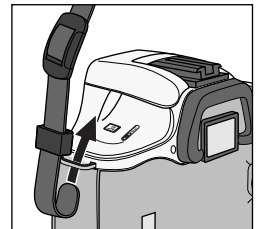

- 4. Pass the tip of the strap through the holder ring.**

- If the ring is tight, fold the strap, and slide the holder ring over the tip (1). Hold the strap, and slide the holder ring in the direction shown (2).

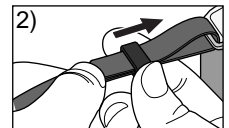
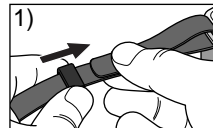
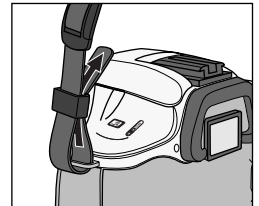

5. Pass the tip of the strap through the buckle and pull to tighten.

- Leave some slack in the camera strap (A) so the tip may be threaded through the buckle easily.

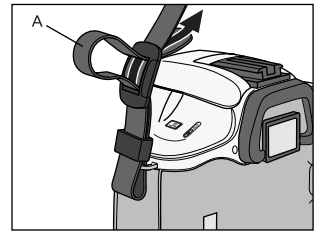

6. Push the holder ring toward the strap eyelet to secure the strap to the camera.

- Repeat with the other end of the camera strap.

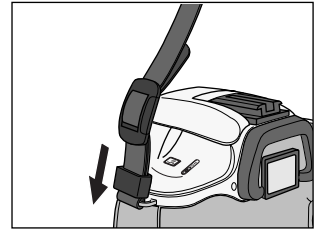

Camera Notes

Take care not to cover the lens or flash with the strap when using the camera. When changing film, be careful not to catch the strap in the camera when closing the back cover.

LENS

GETTING STARTED

Attaching the Lens

This camera uses interchangeable lenses. See page 56 for information on which lenses are compatible with this camera.

1. Remove the body and rear lens caps.

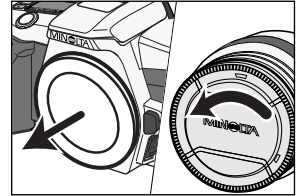

2. Align the red mounting index on the lens and camera body. Carefully insert the lens into the mount, then turn it clockwise until it clicks into the locked position.

- Do not insert the lens at an angle.
- Do not press the lens release button when mounting the lens. The lens will not couple properly.

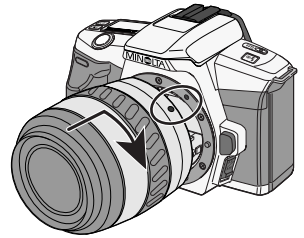

Removing the Lens

While pressing the lens release, turn the lens counter-clockwise until it stops. Carefully remove the lens.

- Replace the cap on the lens and attach the body cap or another lens to the camera.

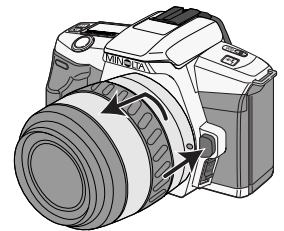

- Never force the lens. If it does not fit, check its orientation with the index marks. When removing, make sure the lens release is pressed all the way down.
- Do not touch the inside of the camera, especially the lens contacts and mirror.

22

FILM

Loading the Film

The camera automatically sets the correct film speed (ISO) with DX-code film. Always load or remove the film under subdued light to reduce the chances of fogging.

- If non-DX-coded film is used, the camera will use the last DX-coded film's ISO setting.
- More than 40 exposures can not be taken on one roll with this camera. When using 72-exposure film, the camera will start to rewind the film after 40 exposures have been made.
- Do not use Polaroid Instant 35mm film. Winding problems may occur.
- Do not use infrared film in this camera. The camera's frame counter sensor will fog infrared film.

1. Check the film window before loading film to confirm the camera is empty.

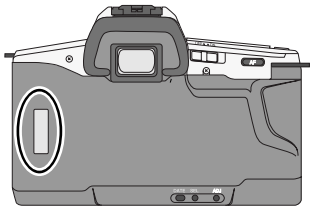

2. Press the back-cover release to open the back cover.

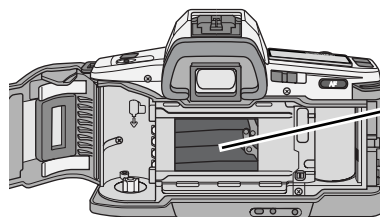
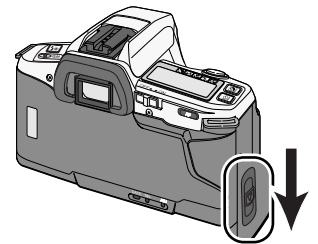

The shutter curtain's precision design makes it extremely sensitive to pressure. Never touch it with your fingers or the film tip.

FILM

GETTING STARTED

3. Insert the film cartridge into the film chamber.

- With the top of the cartridge down, insert the film at an angle into the bottom of the film chamber. Push the cartridge into the chamber until it clicks into place.

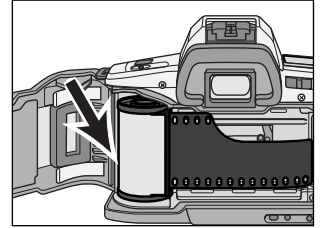

4. Extend the leader between the guide rails to the index mark.

- Hold the film cartridge down so that the film lays flat.
- If the film tip extends beyond the index mark, take the cartridge out and rewind the excess film back into the cartridge.

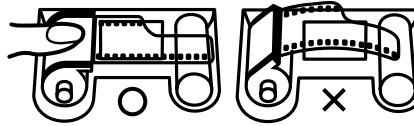
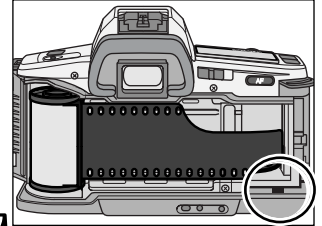

5. Close the back cover.

- The camera automatically advances the film to the first frame.
- Take care not to catch the camera strap when closing the back cover.

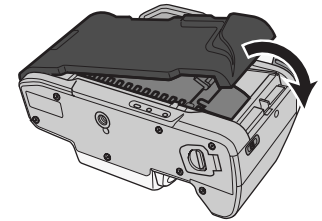

When the film is loaded correctly with the camera on, the frame counter ("1"), cartridge mark, and film transport signals appear on the data panel.



When the film is loaded correctly with the camera off, the frame counter ("1"), cartridge mark, and film transport signals appear on the data panel for approximately five seconds.



When the film is loaded incorrectly, the frame counter ("0") and film transport signals blink on the data panel, and the shutter is locked. If the camera is off, the warning is displayed for approximately five seconds. Open the back cover and reload the film.

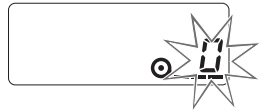

FILM

GETTING STARTED

Rewinding the Film

After you have exposed the last frame, the camera will automatically rewind the film.

1. Wait until the film is completely rewound.

- Zero will be displayed on the frame counter and the cartridge mark will blink on the data panel indicating that the back-cover can be opened safely.



2. Press the back-cover release to open the back cover and remove the film, then close the back cover.

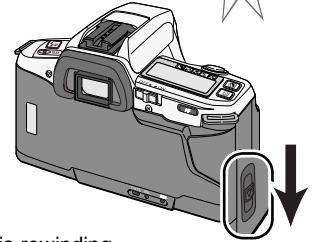

- Do not turn the focusing ring when the film is rewinding.
- Although more pictures than specified on the film package may be taken, the film processor may not print more than the number specified on the film cartridge.

Manual Rewind

Use manual rewind to rewind the film before the roll is finished.

Gently press the manual-rewind button using a pen.

- Only use blunt objects. Sharp objects may damage the camera.
- When the film is rewound, zero will be displayed on the frame counter and the cartridge mark will blink on the data panel indicating that the back-cover can be opened safely.

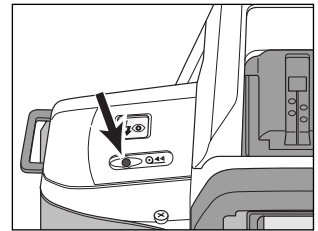

HANDLING THE CAMERA

BASIC OPERATION

Pressing the Shutter-release Button

Press the shutter-release button partway down to activate the camera's autofocus and auto-exposure systems. Press the shutter-release button all the way down to take the picture. When taking a picture, press the shutter-release button with your index finger gently so as not to shake the camera during the exposure.

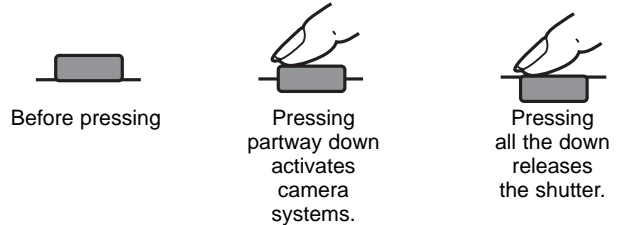

Holding the Camera

Grip the camera firmly with your right hand while supporting the lens with your left. Keep your elbows at your side and your feet shoulder-width apart to hold the camera steady. Keep the camera strap around your neck in the event you accidentally drop the camera.

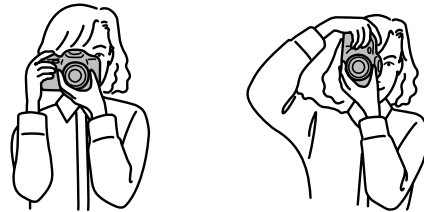

- Lean against a wall or rest your elbows on a solid surface to steady the camera when not using the flash in low-light situations.
- The use of the tripod is recommended when using the camera in low-light situations, with slow shutter speeds, or with telephoto lenses.

TAKING PICTURES

BASIC OPERATION

In the standard operating mode, the camera sets the focus and exposure automatically and fires the built-in flash when necessary. The camera's operation can be optimized for different subjects and situations with subject programs (p. 37), and the drive mode (p. 41) and flash mode (p. 32) can be changed.

1. Slide the main switch to the on position.

- Every time the camera is turned on, the program AE (autoexposure) mode is set and "P" appears on the data panel.
- See p. 54 for details on the camera's default settings.

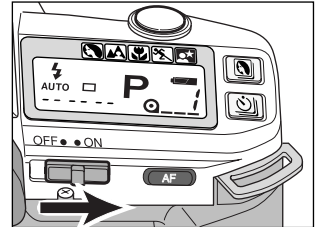

2. Center your subject in the wide focus frame. If using a zoom lens, rotate the zooming ring to frame your subject as desired.

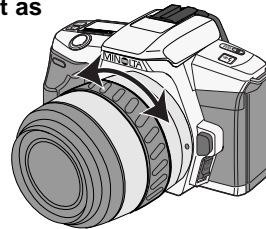

3. Press the shutter release button partway down to activate the autofocus and exposure systems.

- When flash signal appears in the viewfinder, the flash will fire (p. 33).
- In low-light conditions, the AF illuminator will activate to determine focus distance (p. 31).

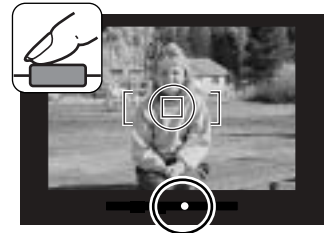

4. When the focus signal appears in the viewfinder, press the shutter-release button all the way down to take the picture.

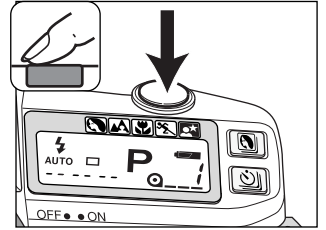

Focus Signals

When the shutter-release button is pressed partway down, the following signals appear in the viewfinder to indicate the focus status.

- Focusing time can be longer with macro or telephoto lenses, or in very dark conditions.

● Steady	Focus is confirmed.
(●) Steady	Focus is confirmed with a moving subject. The camera will continue to focus while the shutter-release button is pressed partway down.
● Blinks	Cannot focus. The shutter is locked (p. 31).

- If the camera is unable to focus, the subject may be too close or one of the special focus situations (P. 31) is preventing the AF system from focusing. Use focus lock (p. 30) or manual focus (p. 47).

FOCUS LOCK

BASIC OPERATION

The focus-lock function is used when the subject is off-center and outside the focus frame. Focus lock may also be used when a special focusing situation prevents the camera from focusing on the subject.



- Focus can also be locked with the spot AF button.
- Focus lock also sets the exposure settings.
- When focusing on moving subjects or with the sports subject program, focus lock cannot be used.

1. Center your subject in the wide focus frame.



2. Press the shutter-release button partway down to lock the focus.

- When focus signal appears in the viewfinder, the focus is locked.



3. Continue to hold the shutter-release button partway down while you compose your picture.

- Removing your finger from the shutter-release button cancels the focus lock.



4. Press the shutter-release button all the way down to take the picture.



30

SPECIAL FOCUS SITUATIONS/ AF ILLUMINATOR

Special Focus Situations

The camera may not be able to focus in the situations described below. Use focus lock (p. 30) or manual focus (p. 47).

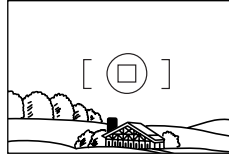

If the subject within the focus frame is very bright, or low in contrast.

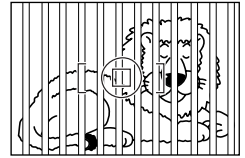

If two subjects at different distances overlap in the focus frame.

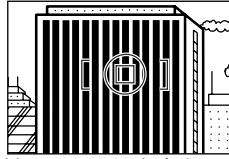

If a subject composed of alternating light and dark lines completely fills the focus frame.

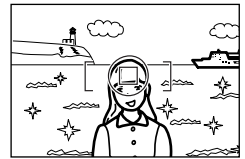

If your subject is near a very bright object or area.

AF Illuminator

The built-in flash is used as an AF Illuminator. When the scene is too dark for the camera to focus, the built-in flash fires a few short bursts when the shutter-release button is pressed part-way down to provide the light necessary for the camera to focus.

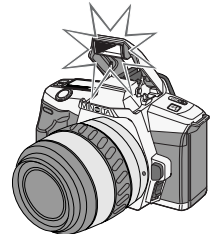

- Pressing the spot AF button can also activate the AF illuminator.
- The range of the AF Illuminator is approximately 1 to 5 m (3.3 to 16.4 ft.).
- The AF illuminator will not fire when focusing on moving subjects or if the flash cancel mode is selected.
- The AF illuminator may not operate with 300mm or longer focal length lenses.
- The AF illuminator will not operate with the Minolta 3x-1x Macro Zoom.
- When an accessory flash is attached, the flash will be used as the AF illuminator in place of the camera's built-in unit.
- See p. 55 on how to cancel the AF illuminator.

USING THE BUILT-IN FLASH

BASIC OPERATION

Changing the Flash Mode

When the flash mode button is pressed, the flash mode changes in the following sequence:

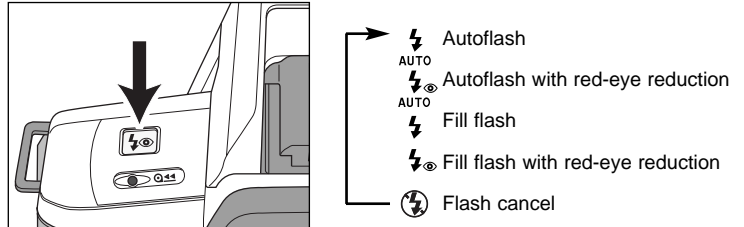

- Except when flash cancel is selected, the built-in-flash will pop-up automatically when the shutter-release button is pressed partway down. Once the flash is up, it will fire when necessary.
- The shutter will not release until the flash is charged.
- Push down the built-in flash when the camera is not in use.
- When the camera is turned off, the flash mode is reset to autoflash or autoflash with red-eye reduction whichever was set last. See p. 36.

Flash Range

The subject must be within the flash range specified in the table below for the image to be properly exposed.



	LENS IN USE			
	28-80mm F3.5-5.6 (D)		35-80mm F4-5.6 II	
Film Speed	Wide angle	Telephoto	Wide angle	Telephoto
ISO 100	1.0 ~ 3.4 m (3.3 ~ 11.2 ft.)	1.0 ~ 2.1 m (3.3 ~ 6.9 ft.)	1.0 ~ 3.0 m (3.3 ~ 9.8 ft.)	1.0 ~ 2.1 m (3.3 ~ 6.9 ft.)
ISO 400	1.0 ~ 4.0 m (3.3 ~ 13.1 ft.)	1.0 ~ 4.0 m (3.3 ~ 13.1 ft.)	1.0 ~ 4.0 m (3.3 ~ 13.1 ft.)	1.0 ~ 4.0 m (3.3 ~ 13.1 ft.)

- Do not use the built-in flash with lenses with focal lengths shorter than 28mm.
- Make sure you are at least 1m (3.3 ft.) from your subject when using the built-in flash.

Flash Signals

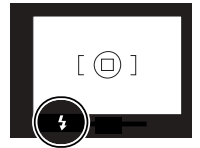
When the shutter-release button is pressed partway down, the viewfinder flash signal indicate the status of the flash.



 Steady	Flash is charged and ready to fire.
 Blinks	The signal will blink after taking the picture to indicate the flash output was sufficient to provide the correct exposure.

- If flash signal does not blink after taking the picture, the subject was not within the flash range. Please check the flash range (p. 32).

Lens Shadowing

Lens shadowing occurs when the lens or lens hood blocks part of the output from the built-in flash. Lens shadowing appears as a semi-circular shadow area at the bottom (horizontal pictures) or side (vertical pictures) of the image.

- Remove the lens hood before using the built-in flash.
- Lens shadowing may occur with the following lenses at the shorter focal lengths.
 - AF Zoom 28-70mm f/2.8G
 - AF Zoom 17-35mm f/3.5G
 - AF Zoom 28-135mm f/4.0-4.5
 - AF Zoom 28-85mm f/3.5-4.5
- The built-in flash can not be used with the following lenses:
 - AF 300mm f/2.8 (APO tele)
 - AF 600mm f/4.0 (APO tele)

USING THE BUILT-IN FLASH

BASIC OPERATION

Autoflash

In auto-flash, the built-in flash pops-up automatically when the shutter release button is pressed partway down in low light situations. Once the flash is up, it will fire when necessary.

Press the flash mode button until the flash mode indicator appears on the data panel.

- When the camera is turned off, the flash mode is reset to autoflash or autoflash with red-eye reduction whichever was set last. See p. 36.

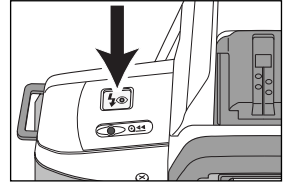

Autoflash with Red-Eye Reduction

Light reflecting from your subject's eyes may produce the effect known as red-eye. Use the built-in flash's red-eye-reduction mode to produce more natural looking photographs by reducing the red-eye effect.

Press the flash mode button until the flash mode indicator appears on the data panel.

- Warn your subject that the flash will fire a few times just before the picture is taken.
- When the camera is turned off, the flash mode is reset to autoflash or autoflash with red-eye reduction whichever was set last. See p. 36.

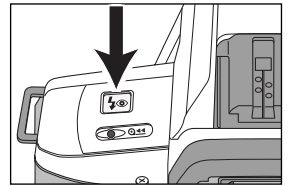

Fill Flash

Use fill flash when taking pictures under fluorescent lighting or to eliminate harsh shadows under strong direct lighting or sunlight. When set, the flash will fire every time a picture is taken.



Press the flash mode button until the flash mode indicator appears on the data panel.

- To return to autoflash mode, repeat the step above until autoflash indicator appears.

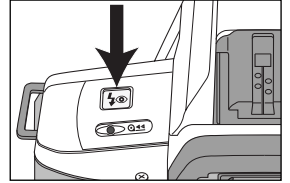

Fill Flash with Red-Eye Reduction

Press the flash mode button until the flash mode indicator appears on the data panel.

- Warn your subject that the flash will fire a few times just before the picture is taken.
- To return to autoflash mode, repeat the step above until autoflash indicator appears.

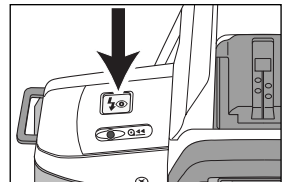

USING THE BUILT-IN FLASH

BASIC OPERATION

Flash Cancel

Use flash cancel to photograph landscapes at twilight, to capture the ambiance of the existing light, or when flash photography is not permitted.



Press the flash mode button until the flash mode indicator appears on the data panel.

- The flash will not fire even if the built-in flash is up.
- The shutter speed may be slow. Use a tripod to reduce camera shake.
- To return to autoflash mode, repeat the step above until autoflash indicator appears.

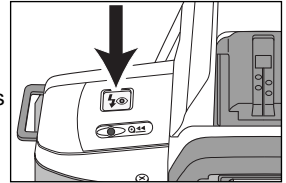

Setting the Default Autoflash Mode

When the camera is turned off, the flash mode is reset to autoflash or autoflash with red-eye reduction whichever of the two modes was set last. The camera's initial setting is autoflash. To have autoflash with red-eye reduction as the default flash mode when the camera is turned on, simply set the mode and turn the camera off.

SUBJECT-PROGRAM SELECTION

The subject-program modes optimize camera settings for specific situations.

Press the subject program button to select any one of the following subject program.

- Set the appropriate flash mode according to the subject program selected. See the following descriptions of each subject program.

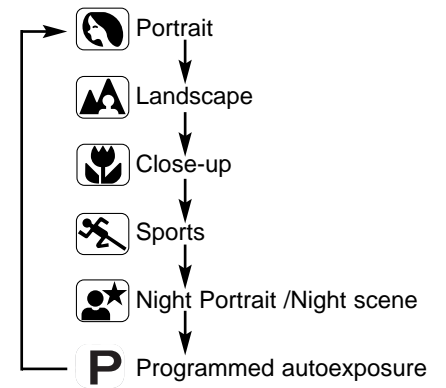
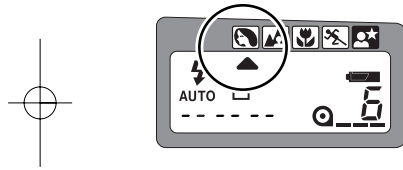
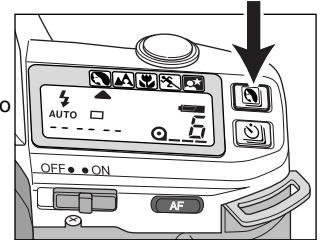

- Every time the camera is turned on, programmed autoexposure mode is set and "P" appears in the data panel.

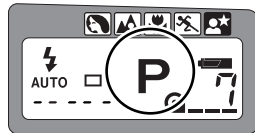

SUBJECT-PROGRAM SELECTION

BASIC OPERATION

Portrait

Portraits have the greatest impact when a shallow depth-of-field is used to separate the subject from the background. Depth-of-field is the area in front of and behind the subject that appears sharp. In portrait mode, the necessary settings are made automatically, leaving you free to capture the perfect expression.



Press the subject-program button until the subject-program indicator points to the portrait mode.

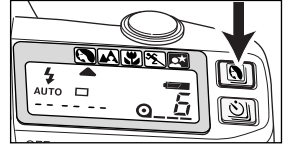

- For best results use the telephoto setting of the lens.
- Use fill flash (p. 35) when your subject is backlit or has strong shadows across the face.
- Focus on your subject's eyes and be ready to capture the perfect expression.
- Use night portrait mode (p. 40) with subjects at night.

Landscape

Landscape photography requires a large depth-of-field to make sure the subject and background are in focus. This mode uses the greatest depth-of-field possible, while maintaining a shutter speed fast enough to prevent blurring from camera shake.



Press the subject-program button until the subject-program indicator points to the landscape mode.

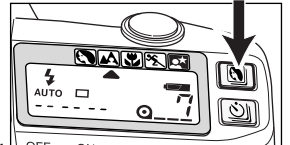

- Use fill flash when a subject in the foreground is backlit or has strong shadows across the face.
- Flash has no effect on landscape pictures.
- For best results use a wide-angle zoom setting or lens. Include a foreground subject or detail to create depth.
- The use of a tripod is recommended.
- Use night portrait mode (p. 40) with scenery at night.

Close-up

Use the close-up mode when photographing small objects like flowers or jewelry. In the close-up mode, the camera automatically sets the best possible aperture and shutter speed for close-up photography. Focusing time can be longer with macro lenses.



Press the subject-program button until the subject-program indicator points to the close-up mode.

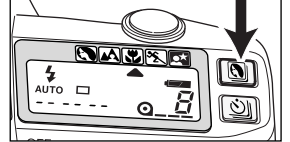

- Use a tripod to reduce camera shake.
- For best results use a macro lens or a macro capable zoom lens.
- Do not use the built-in flash if your subject is closer than 1.0m (3.3 ft.). The flash will overexpose the subject.
- At close distances, the lens or lens hood may block the flash, creating a shadow at the bottom of the image (p. 33). The use of an accessory flash is recommended.
- Make sure the subject is not closer than the minimum focusing distance of lens. Refer to the lens manual.

Sports

Fast shutter speeds are needed to stop action. In the sports mode, the camera will set the fastest possible shutter speed and continually adjust the focus to track moving subjects.



Press the subject-program button until the subject-program indicator points to the sports mode.

- The camera continues to focus as long as the shutter-release button is pressed partway down.
- When using flash, the subject must be within the flash range. When the subject is out of range, use flash cancel (p. 36).
- The use of fast film is recommended.
- Mount the camera on a tripod or monopod when using telephoto lenses.

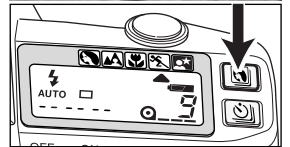

SUBJECT-PROGRAM SELECTION

BASIC OPERATION

Night Portrait

Night portraits balance the camera's flash exposure with the background exposure. In this mode, the camera controls the aperture and shutter speed, allowing the background to appear in the photograph.

1. Press the subject-program button until the subject-program indicator points to the night portrait /night scene mode.
2. Make sure to set any flash mode other than flash cancel (p. 32).

- The use of fast film is recommended.
- Warn your subject not to move after the flash fires; the shutter may still be open to capture the background.
- The shutter speed may be slow. Use a tripod to reduce camera shake.



Night Scene

Cancel the flash in night portrait/night scene mode to photograph views at night. The longer shutter speeds used in this mode allow twilight scenes and night skylines to be captured.

1. Press the subject-program button until the subject-program indicator points to Night Portrait Mode /Night scene mode.
2. Press the flash-mode button to set flash cancel (p. 36).

- Use a tripod to reduce camera shake.
- The use of fast film is recommended.
- Dark night scenes may prevent the AF system from focusing, use focus lock (p. 30) or manual focus (p. 47).
- Night scenes tend to be better at twilight rather than in the darkness of night. The faint light in the early evening sky adds detail to the shadows of the scene.

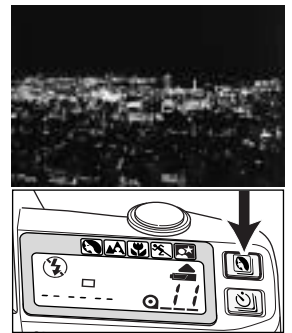

SELF-TIMER

The self-timer delays the release of the shutter for approximately 10 seconds after the shutter-release button is pressed.

1. Place the camera on a tripod. Press the drive-mode button until the self-timer indicator appears on the data panel.

- When the drive mode button is pressed, the drive mode changes in the following sequence:

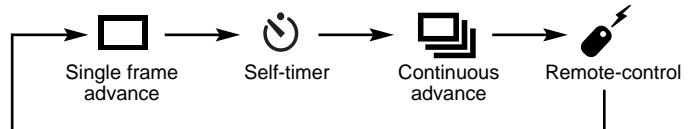
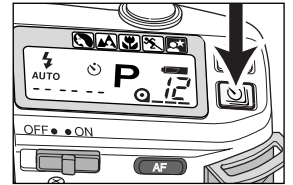

2. Center your subject in the focus frame.



3. Press the shutter-release button partway down to lock the focus.

- Focus lock can be used for off-center subjects (p. 30).

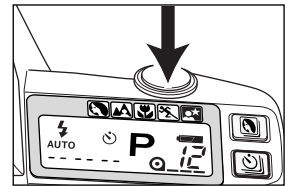
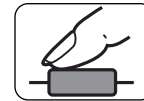

SELF-TIMER

BASIC OPERATION

4. Press the shutter-release button all the way down to start the timer.

- The self-timer lamp on the front of the camera will blink during the countdown. It will glow steadily just before the shutter releases.

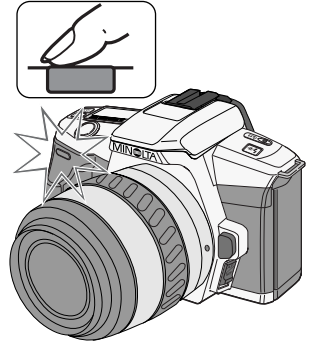

- Do not press the shutter-release button while standing in front of the camera. The focus and exposure is set when the shutter-release button is pressed.
- The self-timer is canceled after the picture is taken.
- To cancel the self-timer countdown, press the drive-mode button or turn the camera off before the shutter releases.
- Attach the eyepiece cap if there is a bright light source behind the camera (p. 20, 57).

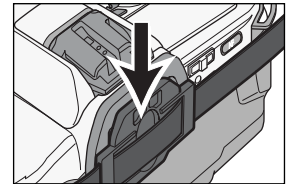

CONTINUOUS ADVANCE

In this mode, the camera continues to release the shutter and advance the film as long as the shutter-release button is held down.

1. Press the drive-mode button until continuous advance indicator appears on the data panel.

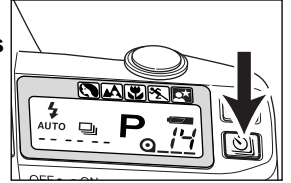

2. Press and hold the shutter-release button to begin taking a series of pictures.

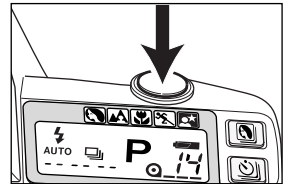

- The camera takes a maximum of 1.7 frames per second when the shutter-speed is 1/250 second or above, flash set to flash cancel, and new batteries. The frame rate is slower when using the built-in flash as the flash must charge between exposures. With accessory flashes, the shutter will continue to release even if the flash is charging.
- With moving subjects or the sports subject program, the shutter will release only when the camera has focused on the subject between exposures.
- To return to single frame mode, press the drive-mode button until single frame advance indicator appears on the data panel.
- AF zoom xi and power zoom lenses cannot be zoomed when taking pictures with continuous advance.

REMOTE-CONTROL FUNCTION FOR OWNERS OF THE QUARTZ-DATE MODEL

BASIC OPERATION

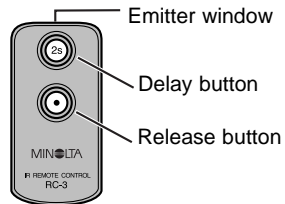

The quartz-date model can be operated up to 5m (16.4 ft.) away with the IR Remote Control RC-3 (sold separately).*

* The quartz-date model is equipped with the remote-control function.

1. Place the camera on a tripod.
2. Press the drive-mode button until remote-control indicator appears on the data panel.
3. Arrange the camera and subject to compose the picture.

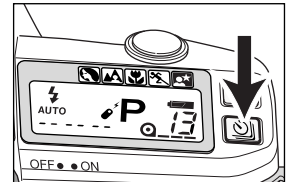

4. Point the emitter window toward the remote-control receiver and press the release or the delay button.

- If the release button is pressed, the lamp on the front of the camera will blink once before the shutter releases.
- If the delay button is pressed, the lamp on the front of the camera will blink for two seconds before the shutter releases.

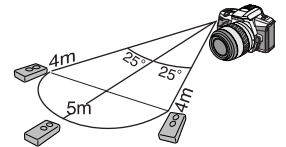

- The remote control may not work under fluorescent lighting or in backlit situations.
- If the built-in flash pops up when the release button on remote control is pressed, wait a few seconds for the flash to charge before pressing the release button again.
- To save power, remote-control mode is canceled if the remote control is not used for more than 5 minutes.
- Attach the eyepiece cap if there is a bright light source behind the camera. See p. 20 and 57.

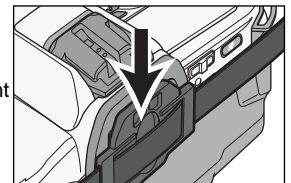

FOCUS LOCK IN REMOTE CONTROL MODE

When your subject is not centered in the focus frame, use manual focus or focus lock. Focus lock cannot be used with moving subjects or the sports subject program.

1. Set the camera to the remote-control mode.

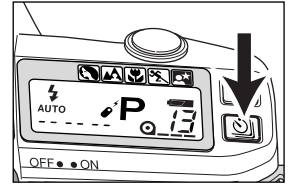

2. Center your subject in the focus frame, then press the shutter-release button partway down until viewfinder focus signal appears.

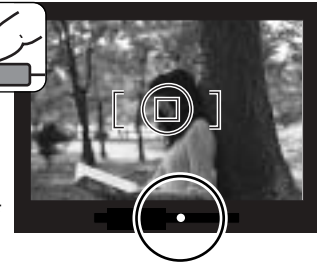

- Focus and exposure is set for the picture.
- Press the shutter-release button partway down again to reset the focus.
- Focus can also be locked with the spot AF button (p. 46).

3. Lift your finger from the shutter-release button.



- The focus signal will remain lit indicating focus lock.

4. Recompose the picture.

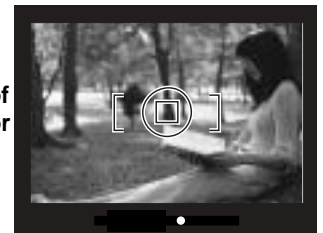

5. Point the remote toward the front of the camera and press the release or delay button.

- The focus lock will remain in effect after the picture is taken allowing multiple remote-control pictures to be made. To cancel the focus lock, select the remote-control mode again with the drive mode button.

SPOT FOCUS

ADVANCED OPERATION

By simply pressing the spot AF button, the center spot focus area is activated.

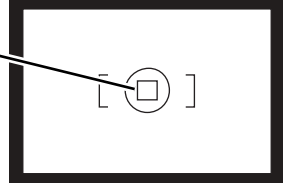

1. Place your subject inside the spot focus area.



2. Press and hold the spot AF button.

- The focus signal appears in the viewfinder.
- Focus and exposure are set and remain locked until the spot focus button is released.

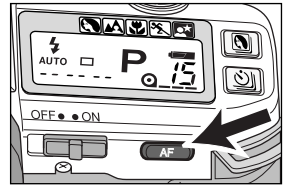

3. While holding the spot AF button, press the shutter-release button all the way down to take the picture.

- When the spot AF button is released, the wide focus frame is active.

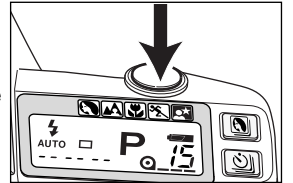

MANUAL FOCUS

The lens can be focused manually. The autofocus system can be used to monitor focus and indicate when a subject in the focus frame is in focus.

1. Slide the focus-mode switch down and release.

- "MF" will appear on the data panel.

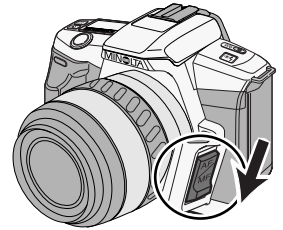
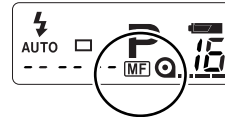

2. Turn the focusing ring until the subject appears sharp.

- When the shutter-release button is pressed partway down, the AF system monitors the focus. The viewfinder focus signal glows when the object in the focus frame is in focus.
- To return to the autofocus mode, slide the focus-mode switch down a second time; the manual focus indicator on the data panel will disappear. Manual focus is canceled when the camera is turned off.

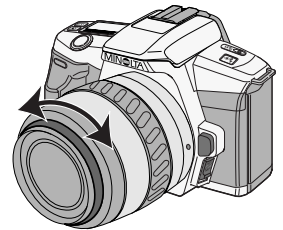

- When using manual focus with 'D' series lenses, multi-segment metering is employed. With other lens, the camera automatically switches to center-weighted metering. The metered exposure may be different between autofocus and manual focus.

FLASH

ADVANCED OPERATION

This section of your manual covers the operation of accessory flashes as well as the built-in flash.

Program Flash

An optional accessory flash improves flash performance over the built-in flash.

Only Minolta D series flash units are compatible with this camera.

Slide the flash units onto the accessory shoe located on the top of the camera.

- The built-in flash should be down before attaching the flash.

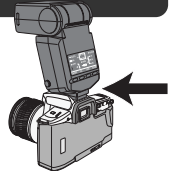

Press the flash-mode button on the camera to select the desired flash mode.

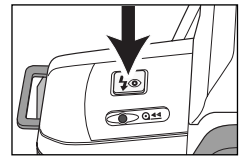
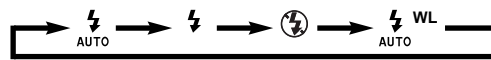

- Red-eye reduction cannot be used with accessory flashes.
- The viewfinder's flash signal shows the status of the accessory flash.
- Refer to the accessory flash's instruction manual for the flash range.
- The shutter speed is set automatically to a 1/90 second or slower. High-speed sync is not compatible with this camera.
- The flash cancel indicator is displayed on the data panel with no other icons when an incompatible flash unit is attached.

Camera Notes

The flash mode can be set with the flash unit. With the flash on and mounted on the camera, change the flash mode on the flash unit. Set the mode by pressing the shutter-release button partway down; the camera will display the corresponding flash mode indicator on the data panel. Only autoflash or flash cancel are available. The other flash modes must be set from the camera.

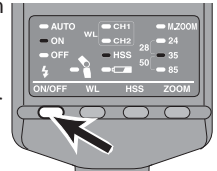

Flash Metering

Flash metering changes according to the lens used.

ADI flash metering

Advanced Distance Integration (ADI) metering is employed when using D series lenses. ADI metering combines distance information from the auto-focusing system with information from a pre-flash exposure. Unlike conventional TTL flash metering, ADI is not influenced by the reference of the subject or background ensuring optimum exposures.



ADI metering



Conventional TTL metering

Pre-flash TTL

Pre-flash TTL metering is used with non-D series lenses or when a wireless / remote flash or bounce flash is used. Like ADI metering, Pre-flash TTL compensates for difference in transmission in the optics by measuring the flash output through the lens, but does not use distance information to calculate the exposure.

Flash Notes

The certain accessories will prevent proper exposure when used with the camera during flash photography. Do not use filters which alter the required exposure such as neutral density or polarizing filters. Do not use close-up filters or lenses on the camera lens, or a close-up diffuser with the flash.

An accessory flash cannot be connected to the camera using a cable. For more on flash accessory compatibility, see page 56.

WIRELESS / REMOTE FLASH

ADVANCED OPERATION

Photographs taken with a flash attached to the camera are flat as shown in example 1. An accessory flash positioned away from the camera creates three-dimensional lighting as shown in the second example.

Wireless / Remote flash uses the camera's built-in flash to control flash units placed around the subject. The proper exposure is determined automatically by the camera.

Red-eye reduction cannot be used with wireless/ remote flash. Since the flash unit is positioned to one side, the red-eye effect will not influence the subject.

Only Minolta D series flash units are compatible with this function.



1. Normal flash



2. Wireless flash

Setting Wireless / Remote Flash Mode

1. With the camera and flash off, mount the flash unit on the camera. Turn both the camera and flash on.

- The flash must first be mounted on the accessory shoe so the camera can set the wireless/ remote function.

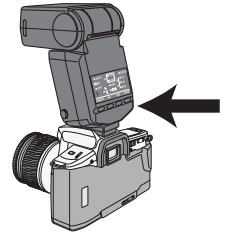

2. Press the flash mode button on the camera until WL appears on the camera's data panel.

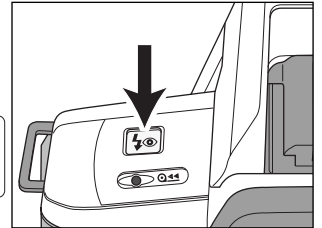

3. Detach the accessory flash.

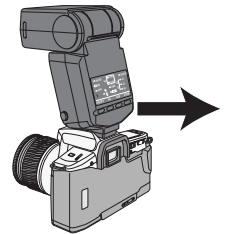

4. Press the camera's flash-mode button to raise the built-in flash.

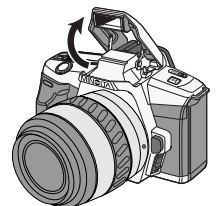

FLASH

ADVANCED OPERATION

Taking Pictures in Wireless / Remote Flash Mode

The accessory flash is controlled by a light signal from the built-in flash. Although the built-in flash fires, it does not add to the exposure, but simply controls the accessory flash. The position of the camera and flash is critical to control the lighting of the subject.

1. Position your camera and flash unit around the subject. See the description below for subject distances.

- Photograph in dark locations.
- Refer to the flash unit's manual for specific information.
- The shutter speed will be set to 1/45 second or slower automatically. The use of a tripod is recommended.
- Ratio-flash control is not available.

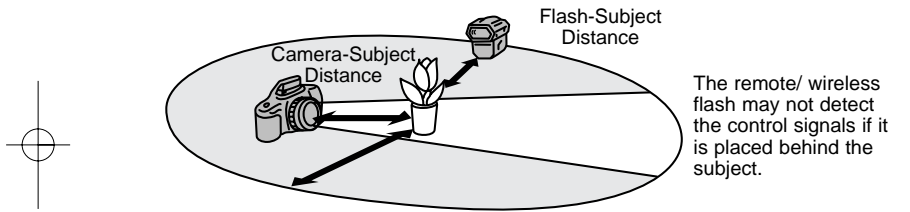

Place the camera and flash unit within a 5 m radius of the subject

- The chart is based on the use of the 35-80mm f/4-5.6 II AF lens.

Film speed	Camera - Subject Distance		3600HS(D) - Subject Distance	
	Wide Angle	Telephoto	Wide angle	Telephoto
ISO 100	1.0 ~ 5.0m (3.3 ~ 16.4ft.)	1.0 ~ 5.0m (3.3 ~ 16.4ft.)	1.0 ~ 3.5m (3.3 ~ 11.5ft)	1.0 ~ 2.5m (3.3 ~ 8.2ft)
ISO 400	2.0 ~ 5.0m (6.6 ~ 16.4ft.)	2.0 ~ 5.0m (6.6 ~ 16.4ft.)	2.0 ~ 5.0m (6.6 ~ 16.4ft.)	2.0 ~ 5.0m (6.6 ~ 16.4ft.)

When using the 5600HS(D) flash, the flash to subject distance is 1.0 ~ 5.0 m (3.3 ~ 16.4 ft) at all focal lengths with ISO 100 film, and 2.0 ~ 5.0 m (6.6 ~ 16.4 ft) with ISO 400 film.

2. Wait until both flash units are fully charged.

- When the shutter-release button is pressed partway down, the viewfinder flash signal will show the status of the built-in flash.
- When the accessory flash is charged, the AF illuminator on the front blinks, and the flash signal on the rear of the unit glows.

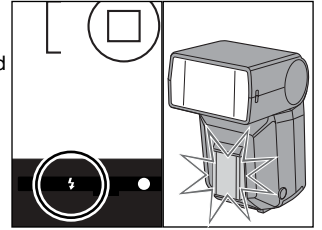

3. Press the subject program button to test fire the wireless/ remote flash.

- If the accessory flash does not fire, change its position.

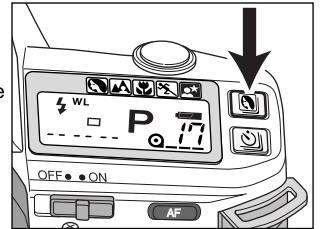

4. When both flash units are fully charged, press the shutter-release button all the way down to take the picture.

- If the exposure from the accessory flash was sufficient for the subject, the flash signal on the flash unit will glow.

Canceling Wireless/ Remote Flash Mode

1. Attach the accessory flash to the camera.
2. Press the flash mode button on the camera until WL no longer appears in the data panel.

- Turning off the camera with the accessory flash attached also cancels wireless flash. If the flash is not attached, the wireless/remote function will not be canceled on the flash unit. Refer to the flash's instruction manual to cancel the function.

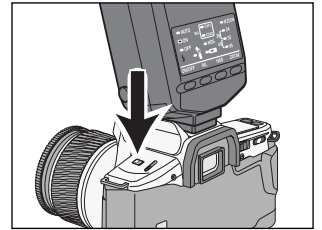

USEFUL INFORMATION

APPENDIX

Reset Default

When the camera is turned off the following functions are reset:

Function	Default Setting	Page
Subject program	Canceled, Program AE active.	37
Flash	Autoflash	32
Focus mode	Autofocus	47
Self-timer	Canceled	41
Continuous advance	Canceled	43
Wireless/remote flash	Canceled	52
Remote-control	Canceled	44

Canceling the Shutter-release Lock

To prevent the film from being fogged, the shutter cannot be released if a lens is not attached to the camera. This can be changed when mounting the camera on a non-dedicated lens mount such a T-mount on a telescope or microscope. Only disable the shutter-release lock when necessary.

1. Turn the camera off.

2. Press and hold subject-program button and drive-mode button.

3. With both buttons held down, turn the camera on.

- Repeat the procedure to activate the shutter-release lock.

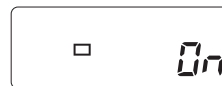
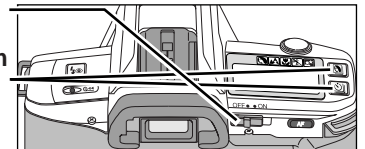

Shutter locked.

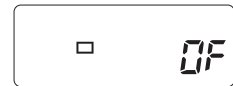

Shutter can be released.

Canceling the AF Illuminator

The built-in flash is used as an AF illuminator and will fire when necessary to assist the autofocus system in low light. The AF illuminator function can be turned off.

- This does not affect an accessory flash's AF illuminator.

1. Turn the camera off.

2. Press and hold flash-mode button.

3. While holding the button down, turn the camera on.



AF illuminator active.



AF illuminator is canceled.

ACCESSORY INFORMATION

APPENDIX

This manual contains information on products and accessories available at the time of printing. To obtain compatibility information for products not contained in the manual, contact a Minolta service facility listed on the back cover.

Lenses

All Minolta AF lenses can be used with this camera.

- Only Minolta A mount lenses are compatible with this camera. MD and MC series lenses cannot be used.
- The certain lens attachments will prevent proper exposure during flash photography. Do not use filters which alter the required exposure such as neutral density or polarizing filters. Do not use close-up filters or lenses.
- ADI metering is compatible with Minolta D series lenses (p. 49).
- Use of a lens hood is recommended to avoid flare (non-image forming light that degrades image quality) when taking pictures without flash.
- Remove the lens hood before using the camera's built-in flash.

Accessory Flashes

The following accessory flash units are compatible with this camera:

Program Flash / Maxxum Flash 5600HS (D)

Program Flash / Maxxum Flash 3600HS (D)

- The flash cancel indicator is displayed on the data panel with no other icons when an incompatible flash unit is attached.
- An accessory flash cannot be connected to the camera using a cable.

AA Battery Pack BP-200

AA Battery Pack BP-200 allows the camera to be powered by four AA alkaline or Ni-MH batteries.

- AA-size lithium batteries cannot be used.

Angle Finder VN / Magnifier VN

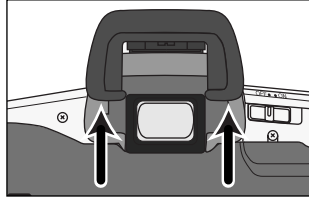

The 90° Angle Finder VN allows the camera to be used in hard-to-view positions or at low angles.

The Magnifier VN enlarges the viewfinder image by approx. 2.3X and is ideal for macro photography, copying, and telephotography.

Remove the eyepiece cup when attaching a finder accessory.

- Push up to remove the eyepiece cup.

Eyepiece Corrector 1000

For eyeglass wearers, an Eyepiece Corrector 1000 can be attached to the viewfinder. Nine correction lenses are available from - 4 to + 3 diopters.

Incompatible Accessories

The following accessories are not compatible with this camera.

- Remote Cords RC-1000 S/L
- Close-up Diffuser CD-1000
- Wireless/Remote Flash Controller
- Off-Camera Cable OC-1100
- Off-Camera shoe OS-1100
- Triple Connector TC-1000
- Cable CD
- Data Receiver DR-1000
- Wireless Controller IR-1N (WARNING: the use of this accessory can permanently damage the camera.)
- Control Grip CG-1000
- Vertical Control Grip VC-7
- Data Saver DS-100

TROUBLESHOOTING

APPENDIX

Contact your nearest Minolta Service Facility if the following information does not cover the problem which you are experiencing or the condition continues.

Problem	Cause	Solution	Page
Autofocus does not work when the shutter-release button is pressed partway down.	Situation is unsuitable for autofocus (p. 31).	Use focus lock or manual focus.	30/ 47
	Camera is set to manual focus mode.	Slide the focus-mode switch down.	47
	Subject is too close.	Check the minimum focus distance of the lens.	–
Shutter cannot be released.	Focus cannot be confirmed.	Use focus lock or manual focus.	30/ 47
	Camera is attached to a microscope or telescope.	Cancel the shutter-release lock.	54
	The lens is not attached correctly.	Attach the lens so that it clicks into place.	22
Flash fires when the shutter-release button is pressed partway down.	Flash is used as AF illuminator to assist the autofocus system.	To turn off the AF illuminator, set the flash mode to flash cancel or cancel AF-illuminator function.	31/ 55

Problem	Cause	Solution	Page
Picture is blurred.	Flash did not fire in a low-light situation and the shutter speed was slow.	Use fill flash, a tripod, or faster film.	–
Flash picture is too dark.	Subject is beyond flash range.	Make sure the subject is within the flash range.	32
When using the built-in flash, the bottom of the picture is dark.	Lens hood was attached or subject distance was less than 1m.	Remove the lens hood. To prevent lens shadowing, the subject must be at least 1m (3.3ft.) from the camera.	32/ 33
The date or time cannot be imprinted.	The date and time are not set or the date imprinting function is off.	The clock and calendar needs to be set if the date and time display blinks. Turn on the date imprinting function.	17/ 18
“Er” appears on the data panel.	Camera malfunction	Turn the camera off and on. If normal camera operation does not resume or the camera malfunctions repeatedly, contact an authorized Minolta Service Facility.	

CARE AND STORAGE

APPENDIX

Operating Temperature and Conditions

- This camera is designed for use from -20° to 50°C (4 to 122 °F).
- Never leave your camera where it may be subjected to extreme temperatures such as in the glove compartment of a car.
- The data panel response time will be slow at cold temperatures. The display will temporarily darken at high temperatures, but will be restored when the temperature normalizes.
- This camera is not waterproof or splashproof. When using the camera in the rain, protect the camera and lens.
- Never subject the camera to extreme humidity.
- To prevent condensation from forming, place the camera in a sealed plastic bag when bringing it from a cold environment to a warm one. Allow it to come to room temperature before removing it from the bag.
- The low-battery symbol may appear even with fresh batteries depending on the storage conditions. To restore camera power, turn the camera off and on several times.
- Battery capacity decreases at colder temperatures. Keep your camera and spare batteries warm when shooting in cold weather. Batteries will regain some of their capacity when warmed to normal operating temperature.

Before Important Events

- Check the camera's operation carefully, or take test photographs.
- Minolta is not responsible for any loss that may occur due to an equipment malfunction.

Cleaning

- If the camera or lens barrel is dirty, wipe it gently with a soft, clean, dry cloth. If the camera or lens comes in contact with sand, gently blow away loose particles - wiping may scratch the surface.
- To clean the lens surface, first brush away any dust or sand then, gently wipe the lens in a circular motion, starting from the center with a cloth or tissue designed for optics. Use lens cleaning fluid if necessary.
- Never place lens fluid directly on the lens.
- Never touch the interior of the camera, especially the shutter and mirror, doing so may impair their alignment and movement.
- Dust on the mirror will not affect the exposure but may affect the focus. Use a blower brush to remove dust from or around the mirror.
- Never use compressed air to clean the camera's interior, it may damage delicate internal mechanisms.
- Never use organic solvents to clean the camera.
- Never touch the lens surface with your fingers.

Storage

When storing your camera for extended periods:

- Always attach the protective caps.
- Store in a cool, dry, well-ventilated area away from dust and chemicals such as naphthalene or moth balls. For long periods of disuse, place the camera in an airtight container with a silica-gel drying agent.
- Periodically release the camera's shutter to keep it operating properly.
- Before using after prolonged storage, check the camera's operation to make sure it is functioning properly.

Questions and Service

- If you have questions about your camera, contact your local camera dealer or write to the Minolta distributor in your area.
- Before shipping your camera for repair, contact an authorized Minolta Service Facility.

SPECIFICATIONS

APPENDIX

CAMERA TYPE:	35mm autofocus SLR with autoexposure (AE) and a built-in flash
LENS MOUNT:	Minolta A mount
AUTOFOCUS SYSTEM:	
Detection system:	TTL phase-detection
Autofocus sensors:	CCD line sensors (3-point AF system with a center cross-hair sensor)
Autofocus sensitivity range:	Ev -1 – 18 (ISO 100)
AF illuminator:	Built-in flash Automatically activates in low light, low-contrast situations. Range: 1 - 5m / 3.3 – 16.4 ft. (approx.)
Autofocus areas:	Wide focus area, Spot focus area
Predictive focus control:	Multi-dimensional predictive focus control for moving subjects
EXPOSURE SYSTEM:	
Metering:	TTL, 14-segment honeycomb-pattern metering
Metering cell:	14-segment honeycomb-pattern SPC
Metering range:	Ev 1-20 (ISO 100, f/1.4 lens)
Exposure control:	Programmed AE
Subject programs:	Portrait, Landscape, Close-up, Sports, Night portrait - Automatic with DX-coded film between ISO 25 – 5000 in 1/3 Ev increments. - ISO 25 – 1000 with flash
ISO settings:	
AE lock:	Exposure is locked with focus.
SHUTTER:	
Type:	Electronically-controlled, vertical-traverse, focal-plane shutter
Speed range:	30 - 1/2000 s
Flash-sync speed:	1/90 s or slower
Wireless/Remote flash-sync speed:	1/45s or slower.
FLASH:	
Flash metering:	Pre-flash TTL, ADI
Type:	Built-in
Guide number:	12 (in meters at ISO 100) /39 (in feet at ISO 100)
Flash range:	1 - 4m / 3.3 – 13.1 ft.
Flash coverage:	28mm angle of view
Flash modes:	Autoflash, Autoflash with red-eye reduction, Fill flash, Fill flash with red-eye reduction, Flash cancel, Wireless/Remote flash (with dedicated flash units)
Recycling time:	4 s (approx.)

VIEWFINDER:

Type: Eye-level fixed roof mirror
 Focusing screen: Spherical acute matte
 Field of view: 90% (vert.) x 90% (hor.)
 Magnification: 0.75x (with 50mm lens focused at infinity)
 Eye relief: 16mm (13mm from the eyepiece frame)
 Diopter: -1 diopter
 Eyepiece cup: Removable

FILM TRANSPORT:

Film advance: Single-frame advance, Continuous advance
 Continuous advance speed: 1.7 fps (max.)
 Loading: Automatic loading
 Rewinding: Automatic rewind, Manual rewind
 Rewind time: 8 s (approx.) with 24-exposure film

Self-timer: 10 s
 IR remote control receiver: Quartz-date model only
 IR Remote Control RC-3 (sold separately)

POWER:

Two 3V CR2 lithium batteries
 Battery performance:

Flash Use (%)	Condition A		Condition B	
	20 °C (68 °F)	-10 °C (14°F)	20 °C (68 °F)	-10 °C (14°F)
0	30 rolls	24 rolls	45 rolls	35 rolls
50	14 rolls	11 rolls	18 rolls	14 rolls
100	9 rolls	7 rolls	11 rolls	9 rolls

Condition A:

Lens (35-80 f/4-5.6 II) focused from infinity to 2m (6.6ft.) three times, and the shutter-release button held partway down for ten seconds before each exposure. Other basic photographic procedures are performed.

Condition B:

Lens focused from infinity to 2m (6.6ft.), and the shutter-release button held partway down for five seconds before each exposure. Other basic photographic procedures are performed.

- With 24-exposure film, fresh battery. Exposures taken at a rate of 2 rolls per month.
- Battery performance will vary with usage conditions

DIMENSIONS:

127(W) x 87(H) x 60.5(D) mm
 5(W)x 3.4(H)x 2.4(D) in.

WEIGHT:

310g (10.9oz.) without batteries, accessories, or attachments

Specifications are based on the latest information available at the time of printing and are subject to change without notice.

Minolta Co., Ltd.	3-13, 2-Chome, Azuchi-Machi, Chuo-Ku, Osaka 541-8556, Japan
Minolta Europe GmbH	Minoltaring 11, D-30855 Langenhagen, Germany
Reparatur/Repair	Senator-Helmken-Strasse 1, D-28197 Bremen, Germany
Minolta France S.A.S.	365 Route de Saint-Germain, F-78420 Carrieres-Sur-Seine, France
Minolta (UK) Limited	7 Tanners Drive, Blakelands, Milton Keynes, MK14 5BU, England
Minolta Austria Ges. m.b.H.	Amalienstrasse 59-61, A-1131 Wien, Austria
Minolta Camera Benelux B.V.	Zonnebaan 39, P.O. Box 6000, NL-3600 HA Maarssen, The Netherlands
Belgian Branch	Prins Boudewijnlaan 1, B-2550 Kontich, Belgium
Minolta (Schweiz) AG	Riedstrasse 6, CH-8953 Dietikon, Switzerland
Minolta Svenska AB	Albygatan 114, S-171 54 Solna, Sweden
Finnish Branch	Niittykatu 6 PL 37, SF-02201 Espoo, Finland
Minolta Portugal Limitada	Av. do Brasil 33-A, P-1700 Lisboa, Portugal
Minolta Corporation	101 Williams Drive, Ramsey, New Jersey 07446, U.S.A.
Minolta Canada Inc.	369 Britannia Road East, Mississauga, Ontario L4Z 2H5, Canada
Minolta Hong Kong Limited	Room 208, 2/F, Eastern Center, 1065 King's Road, Quarry Bay, Hong Kong
Minolta Singapore (Pte) Ltd.	10, Teban Gardens Crescent, Singapore 608923
Shanghai Minolta Optical Products Co., Ltd.	368 Minolta Road, Songjiang, Shanghai, China



© 2003 Minolta Co., Ltd. under the Berne Convention and Universal Copyright Convention

9222-2165-11 P-B302
Printed in Japan

Free Manuals Download Website

<http://myh66.com>

<http://usermanuals.us>

<http://www.somanuals.com>

<http://www.4manuals.cc>

<http://www.manual-lib.com>

<http://www.404manual.com>

<http://www.luxmanual.com>

<http://aubethermostatmanual.com>

Golf course search by state

<http://golfingnear.com>

Email search by domain

<http://emailbydomain.com>

Auto manuals search

<http://auto.somanuals.com>

TV manuals search

<http://tv.somanuals.com>