

# MINOLTA

# *VECTIS*

# S-100

**E**

**INSTRUCTION  
MANUAL**



**BASIC  
OPERATION**

**ADVANCED  
OPERATION**

**ADDITIONAL  
FEATURES**

**APPENDIX**

Thank you for purchasing the Minolta Vectis S-100. The Vectis S-100 is an ultra compact IX240 type system camera with variable print-aspect-ratio and magnetic storage of date and exposure information. The Vectis S-100 also incorporates the revolutionary TTL side viewfinder. The side viewfinder provides a high viewfinder magnification, high eyepoint, and large diopter range, in addition to giving the camera its distinctive profile.

This manual has been designed to help you understand the operation of the camera more quickly. After familiarizing yourself with the camera, read the Basic Operation section. Refer to the Advanced Operation and Additional Features sections as your familiarity with the camera increases.

Advanced Photo System™ is a trademark of the five system developing companies.

## Advantages of the Advanced Photo System

### Easier to load...

Advanced Photo System cameras use the new IX240 type film. This new film features drop-in-loading to make loading your camera simple, the first time, every time.

Indicators on the cassette tell you and your camera if the film is unexposed, partially exposed, exposed, or processed.

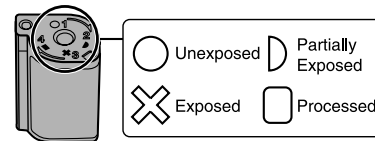

### New print formats...

Classic (C), wider (H), and panorama (P) print formats are available with Advanced Photo System cameras.

### New processing...

In addition to returning your prints in the format you selected, certified photofinishers will return your Advanced Photo System film in its original cassette with an index print. To order reprints, simply choose the images you want from the index print. No more searching through negatives to find the right frame.

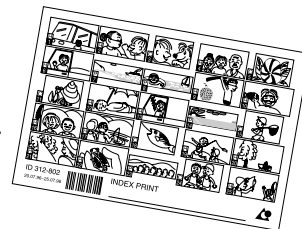

# TABLE OF CONTENTS

<b>FOR PROPER AND SAFE USE</b> .....	4
<b>NAMES OF PARTS</b> .....	9
<b>QUICK OPERATION</b> .....	14

## **BASIC OPERATION**

Attaching the Strap .....	17
Installing the Batteries .....	18
Checking the Battery Power.....	19
Attaching and Removing the Lens .....	20
Diopter Adjustment .....	22
Handling the Camera.....	23
Loading Film .....	24
Full Auto Operation .....	28
Special Focusing Situations .....	30
Focus Hold.....	31
Using the Built-In Flash	
Flash Lamp.....	32
Flash Range .....	32
Manual Fill-Flash .....	33
Flash Cancel.....	33
Red-Eye Reduction .....	34
Rewinding the Film .....	35

## **ADVANCED OPERATION**

Subject Program Modes	
Portrait Mode .....	38
Landscape Mode .....	39
Close-up Mode .....	40
Sports Mode .....	41
Night Portrait Mode.....	42
Photographing Night Scenes .....	43
Creative Exposure Modes	
Aperture Priority Mode .....	45
Shutter Priority Mode.....	48

## **ADDITIONAL FEATURES**

Date/Time Imprinting.....	52
Manual Focus .....	56
Self-Timer.....	57
Continuous-Drive Mode.....	58
Remote Control (optional) .....	59
AF Illuminator.....	63
Exposure Compensation .....	64
Wireless/Remote Off-Camera Flash .....	66

## **APPENDIX**

Program Reset.....	71
Lab Services .....	72
Accessory Information .....	74
Care and Storage .....	76
Specifications .....	78
Trouble Shooting.....	80
Camera Warnings.....	82
Quick Reference .....	84

# FOR PROPER AND SAFE USE

Read and understand all warnings and cautions before using this product.

## WARNING

Batteries may become hot or explode due to improper use.

- Use only the batteries specified in this instruction manual.
- Do not install the batteries with the polarity (+/-) reversed.
- Do not subject batteries to fire or high temperatures.
- Do not attempt to recharge, short, or disassemble.
- Do not mix batteries of different types, brands, or ages.

Use caution, accidents may occur when using this product near young children.

Keep batteries or things that could be swallowed away from young children. Contact a doctor immediately if an object is swallowed.

Immediately remove the batteries and discontinue use if...

- the camera is dropped or subjected to an impact in which the interior is exposed.
- the product emits a strange smell, heat, or smoke.

## WARNING

Do not disassemble. Electric shock may occur if a high voltage circuit inside the camera is touched. Take your camera to a Minolta Service Facility when repairs are required.

Do not look directly at the sun through the viewfinder.

Fire may occur if the camera is subjected to focused sunlight. Replace the lens cap when the product is not being used.

### Splashproof

This camera is splashproof and can be used in light rain or snow.

- Do not place the camera under running water or immerse.

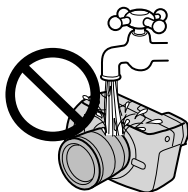

### Please Note:

- When using the camera outdoors in heavy rain, keep the camera protected from the rain.
- Do not leave the camera in the rain.
- The interior of the camera is not moisture resistant.
  - Dry the camera before changing lenses or opening the film and battery chambers.
  - Keep your hands dry when changing lenses or opening the film and battery chambers.
- Do not load film or replace batteries in places where water, blowing sand, or dust can enter the camera.
- This camera is not sandproof, do not place the camera directly on the ground.
- Remove moisture from the camera.
- Do not expose the camera to salt water or liquids containing sugar.
- If the rubber seals appear cracked or damaged, contact the nearest Minolta Service Facility to have them replaced.
- Close the film and battery-chamber covers tightly. Clean the rubber seals before closing covers.



### Operating Temperature and Conditions

- This camera is designed for use from -10 to 50 °C (14 to 122 °F).
- Never leave your camera where it may be subjected to extreme temperatures such as the glove compartment of a car.
- At colder temperatures, the data panel response time will be slow. The display will temporarily darken at higher temperatures, but will restore when the temperature normalizes.
- Never subject the camera to extreme humidity.
- To prevent condensation from forming, place the camera in a sealed plastic bag when bringing it from the cold exterior into a warm building. Allow it to come to room temperature before removing it from the bag.
- The low-battery symbol may appear even with fresh batteries depending on the storage conditions. To restore camera power, repeat turning the camera on and off.
- When photographing in cold weather, keep the camera and spare batteries inside your coat to keep them warm when you are not shooting. Cold batteries will regain some of their charge when they warm up.



## Film Cassette Warning

The film used in Advanced Photo System cameras stores some data magnetically. Do not place the cassette on or near anything that creates a magnetic field, such as a television or stereo speakers.

This device complies with Part 15 of the FCC Rules. Operation is subject to the following two conditions: (1) This device may not cause harmful interference, and (2) this device must accept any interference received, including interference that may cause undesired operation. Changes or modifications not approved by the party responsible for compliance could void the user's authority to operate the equipment. This equipment has been tested and found to comply with the limits for a Class B digital device, pursuant to Part 15 of the FCC Rules. These limits are designed to provide reasonable protection against harmful interference in a residential installation. This equipment generates, uses and can radiate radio frequency energy and, if not installed and used in accordance with the instructions, may cause harmful interference to radio communications. However, there is no guarantee that interference will not occur in a particular installation.

If this equipment does cause harmful interference to radio or television reception, which can be determined by turning the equipment off and on, the user is encouraged to try to correct the interference by one or more of the following measures:

- Reorient or relocate the receiving antenna.
- Increase the separation between the equipment and the receiver.
- Connect the equipment to an outlet on a circuit different from that to which the receiver is connected.
- Consult the dealer or an experienced radio/TV technician for help.

This Class B digital apparatus meets all requirements of the Canadian Interference-Causing Equipment Regulations.

## NAMES OF PARTS

For information on specific parts, refer to the page numbers shown in parenthesis.

### Body

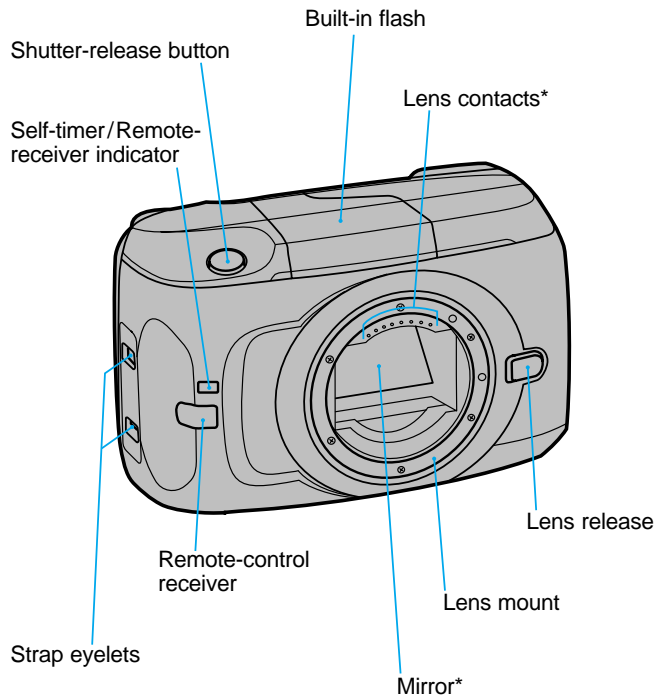

\* Do not touch

## NAMES OF PARTS

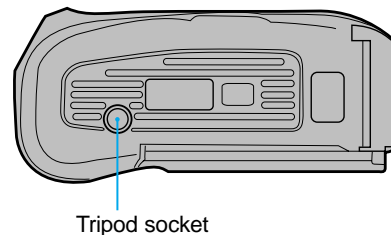
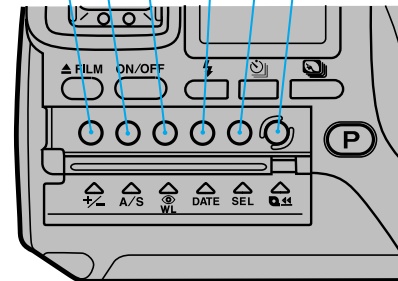
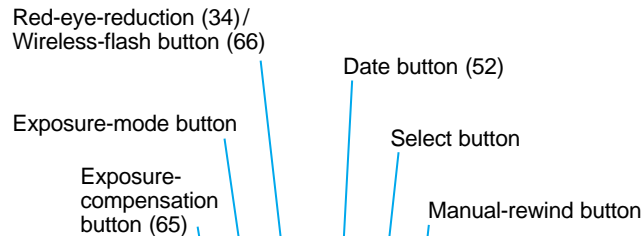
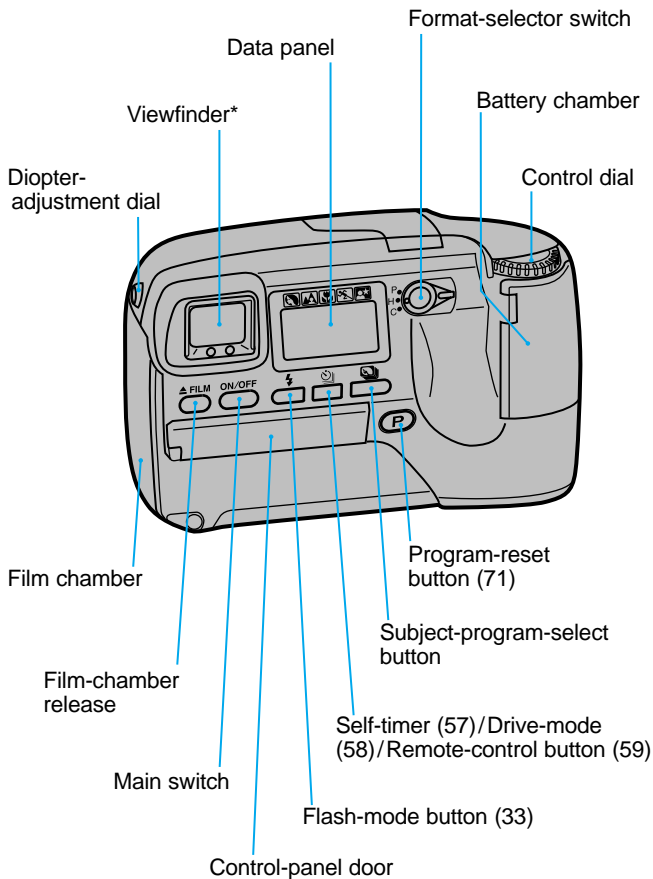

\* Do not touch

## NAMES OF PARTS

### Data Panel

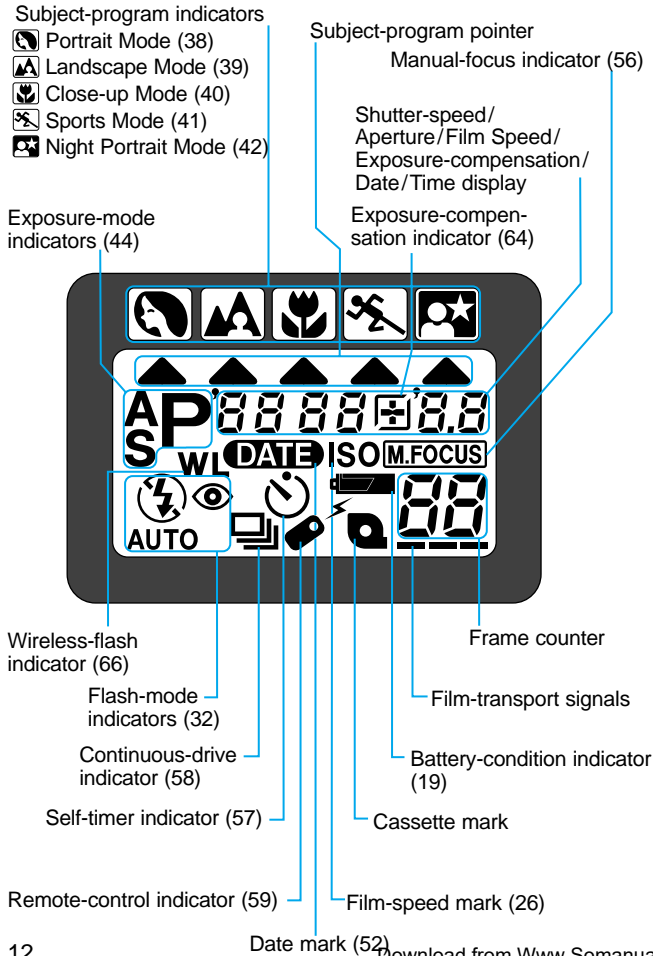

### Viewfinder

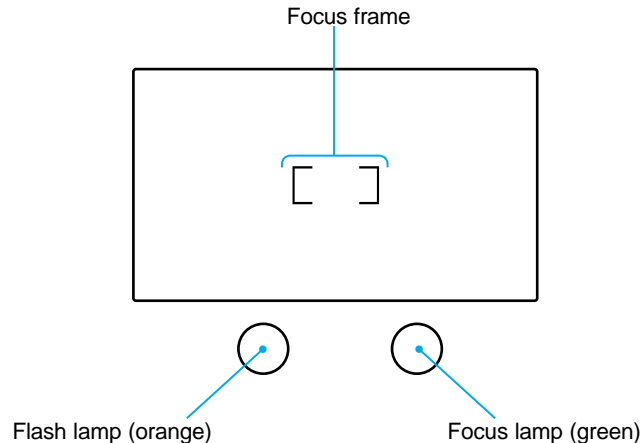

#### Focus Lamp

glows	Focus is confirmed
blinking	Focus is not confirmed. Shutter cannot be released

#### Flash Lamp

glows	Flash is charged
blinks fast	Flash is charging. Shutter cannot be released
blinks slow	Warning - light level is low, use flash or a tripod.



# QUICK OPERATION

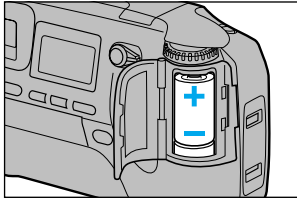

## 1. Insert battery

Open the battery-chamber door using the eyepiece cap. Insert the batteries into the chamber, then snap the battery-chamber door shut.

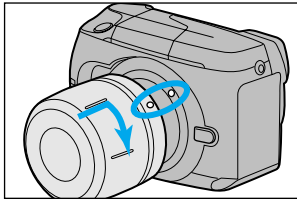

## 2. Attach lens

Align the red mounting dot on the lens with the one on the camera. Gently insert the lens into the mount and turn it clockwise until it clicks into the locked position.

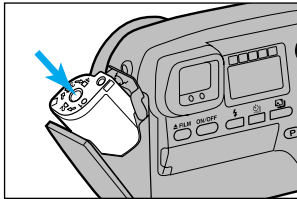

## 3. Insert film

Press the film-chamber release. Insert the film cassette. Close the film-chamber door.

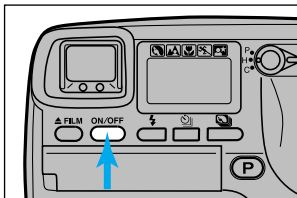

## 4. Turn on power

Press the main switch to turn the camera on.

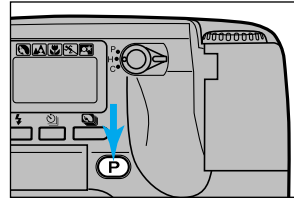

## 5. Set Full Auto Operation

Press the program-reset button to set the camera to fully-automatic operation.

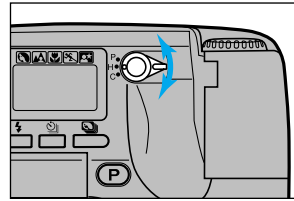

## 6. Select print format

Turn the format-selector switch to the desired format before taking the picture.



## 7. Focus on the subject

Align the subject within the focus frame , then press the shutter-release button partway down.

The focus lamp will light when the subject is in focus. The flash will pop-up and fire when necessary.

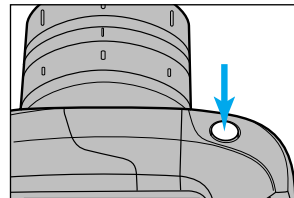

## 8. Take the picture

Gently press the shutter-release button all the way down to take the picture.

# BASIC OPERATION

This section provides the information necessary to operate your camera in most photographic situations.

This section covers:

- Battery Installation
- Attaching and Removing the Lens
- Diopter Adjustment and Camera Handling
- Loading and Rewinding the Film
- Fully Automatic Camera Operation
- Special Focus Situations
- Basic Flash Operation

Once you fully understand the instructions in this section, proceed to the Advanced Operation and Additional Features sections to obtain more enjoyment from your camera.

## ATTACHING THE STRAP

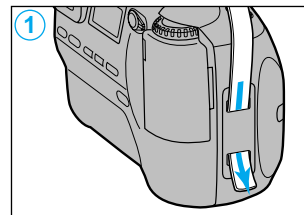
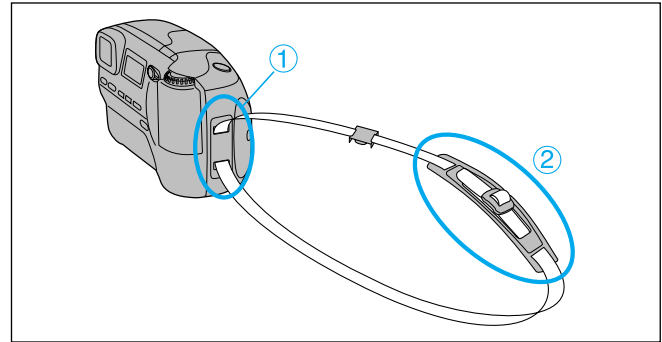

**Attach the camera strap as shown.**

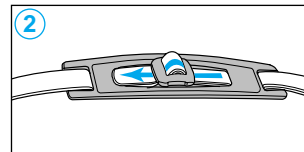

## INSTALLING THE BATTERIES

Your camera uses two CR2 batteries to supply power for all camera operations.

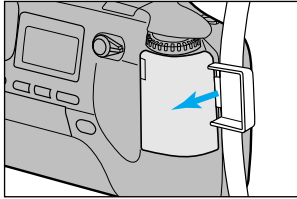

### 1. Using the eyepiece cap, open the battery-chamber door.

- Turn the camera off before removing the old batteries.
- Remove dirt and moisture from the camera and batteries before opening the battery-chamber door.

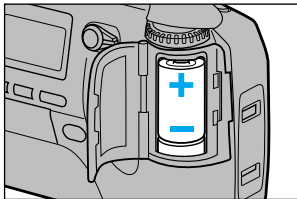



- ### 2. Insert the batteries as indicated by the + and - marks.
- ### 3. Snap the battery-chamber door shut.

- If the battery-chamber cover is not closed properly, moisture may enter the camera.
- If **DATE** and - - - - - - blink in the data panel after the camera is turned on, reset the date and time. See page 52.

## CHECKING THE BATTERY POWER

Your camera is equipped with an automatic battery-power indicator. Each time the camera is turned on, the battery symbol will appear in the data panel to indicate the power status of the batteries.

 <p>Full-battery symbol</p>	Power is sufficient for all camera operations.
 <p>Blinking low-battery symbol</p>	Power is extremely low, but all functions are operational. Battery will need to be replaced very soon. Flash recycling time may be slow.
 <p>Blinking low-battery symbol appears alone and the shutter locks</p>	Power is insufficient for camera operation.

- If no display appears, replace the battery or check that it is inserted correctly.
- Your camera shuts down if it is not operated for more than 30 minutes. Press the main switch to restore power.

# ATTACHING AND REMOVING THE LENS

## Attaching the Lens

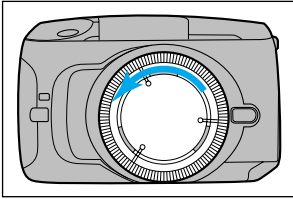

1. Remove the body cap.

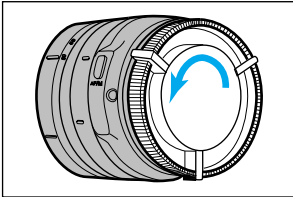

2. Remove the rear lens cap.

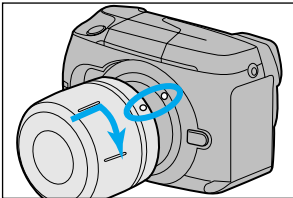

3. Align the red mounting dots on the lens and camera body.  
4. Gently insert the lens into the mount, then turn clockwise until it clicks into the locked position.

- Do not insert the lens at an angle.
- Do not press the lens release when attaching the lens.

## Removing the Lens

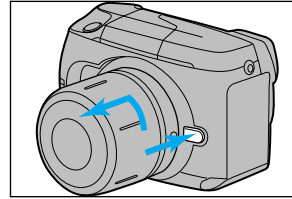

1. Press the lens release and turn the lens counter-clockwise until it stops.  
2. Gently remove the lens from the mount and replace the caps, or attach another lens.

### Lens Hood Note

Attach a lens hood (page 74) to reduce flare and ensure maximum image quality. Flare reduces the contrast of the final image.

### Caution

- Do not force the lens if it does not turn smoothly.
- Do not touch the inside of the camera, especially the lens contacts and mirror.
- Remove dust and dirt from the lens mount before attaching or removing a lens.

# DIOPTER ADJUSTMENT

If you are near or far sighted, you can adjust the eyepiece for your eyesight. The diopter adjustment range is from -3.0 to +1.0 diopters.

## Adjusting the Diopter:

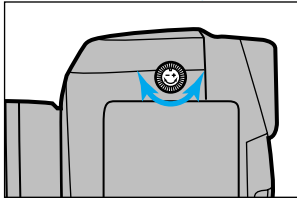

1. Center your subject in the focus frame.
2. Press the shutter-release button partway down to focus on the subject.
3. Turn the diopter-adjustment dial until the subject appears sharpest.

# HANDLING THE CAMERA

## Holding the Camera

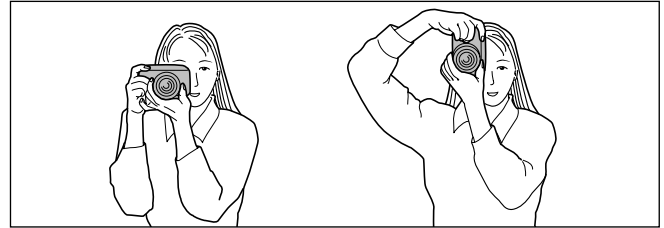

Grip the camera firmly with your right hand, while supporting the lens with your left hand. Make sure your fingers don't block the flash. Your fingers should fit securely around the grip. Keep your elbows at your side and your feet shoulder-width apart to hold the camera steady. Always keep the camera strap around your neck or wrist in the event you accidentally drop the camera.

## Pressing the shutter-release button

Press the shutter-release button partway down to activate the camera's autofocus and auto-exposure systems. Gently press the shutter-release button all the way down to take the picture.

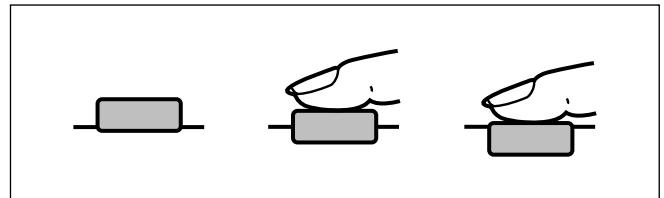

# LOADING FILM

Use IX240 type film in this camera.

- The automatic transport system will load the film, set the film speed, and advance the film after each exposure.
- Once loaded, the film chamber cannot be opened until the film is rewound into the cassette (Film Chamber Lock).
- There is no need to worry about double exposure. The DEP (Double Exposure Prevention) feature prevents the camera from accepting exposed film.

## Visual Exposure Indicators

- The current VEI has a white indicator behind it.
- This camera can only load film with the ● VEI current.

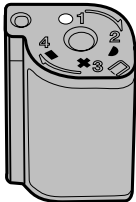

VEI	MEANING
●	UNEXPOSED
◐	PARTIALLY EXPOSED
✕	EXPOSED
■	PROCESSED

## Loading the Film

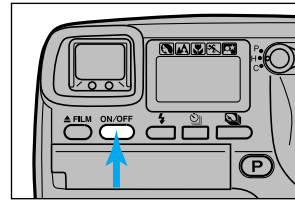

1. Press the main switch to turn the camera on.
  - Film can be loaded when the camera is on or off.

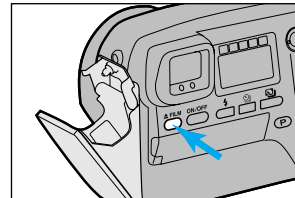

2. Press the film-chamber release on the back of the camera. The film-chamber door will open.

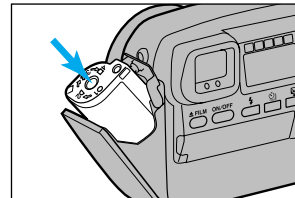

3. Insert a new film cassette into the film chamber with the VEI on top.

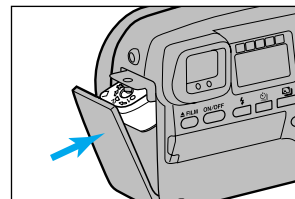

4. Push the film chamber in until it clicks shut.

## LOADING FILM



The film speed appears in the data panel, then the film is advanced to the first frame.



When the loading sequence is complete, the frame counter displays the number of frames remaining on the roll.

- If the shutter-release button is not pressed after loading, an unexposed (●) roll can be removed by pressing the rewind button, then the film-chamber release. The VEI will be unchanged.
- If film is loaded with the power off, all indicators in the data panel will disappear after the number of frames remaining is displayed.
- After the film is loaded, pressing the film-chamber release will display the film speed and the frame number in the data panel.

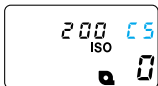

- If slide film is loaded, **CS** will appear in the data panel when the film-chamber door is closed.

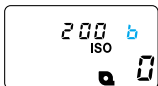

- If black and white film is loaded, **b** will appear in the data panel when the film-chamber door is closed.

A diagram of a film cassette with three blue arrows pointing to the VEI (Viewfinder Exposure Indicator) area.

- If blinks in the data panel, press the film-chamber release and remove the film.
  - Your camera cannot load a film cassette, if the current VEI is **X**, , or . Only load cassettes with the mark current.
  - If a processed () or partially exposed () roll of film was loaded into this camera, the VEI has been to **X** (exposed).
  - If the cassette's current VEI is , remove the film. Remove and reinsert the batteries, then reload the film. If the film will not load, contact the nearest authorized Minolta Service Facility.

# FULLY AUTOMATIC OPERATION

Full Auto is the camera's standard operating mode and is suited for use in almost any situation.

- Press the program-reset button to set the camera to fully automatic operation (Full Auto) at any time. See page 71.

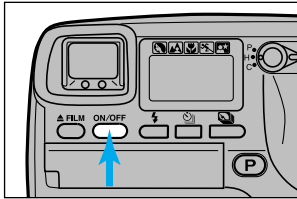

1. Press the main switch to turn the camera on.

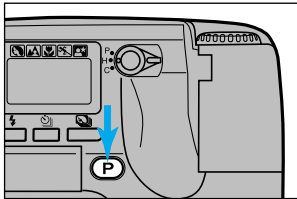

2. Press the program-reset button to set the camera to Full Auto.

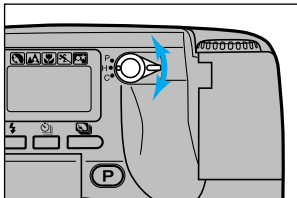

3. Set the format-selector switch to the desired print format (C, H, or P).



4. Center your subject in the focus frame  and press the shutter-release button partway down to activate autofocus. The focus lamp will glow when the subject is in focus.

- The built-in flash will pop-up and fire when necessary.

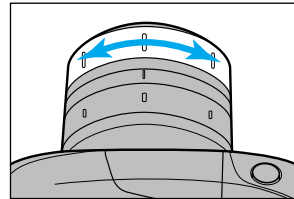

5. When using a zoom lens, rotate the zooming ring on the lens to frame the subject as desired.

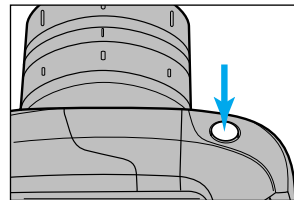

6. Press the shutter-release button all the way down to take the picture.

- In low-light conditions, the AF Illuminator (flash) will fire to determine the focus distance.
- If your subject is outside the focus frame , use focus hold. See page 31.



# SPECIAL FOCUSING SITUATIONS

The camera may not be able to focus in situations like those described below. When the focus lamp blinks, use focus hold (page 31) or manual focus (page 56). See page 13 for an explanation of the focus signals.

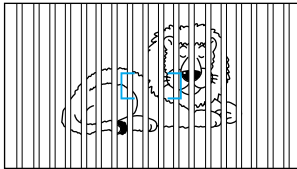

If two subjects at different distances overlap in the focus frame [ ],

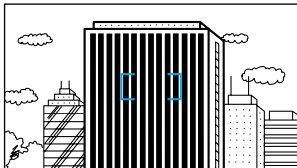

If a subject composed of alternating light and dark lines completely fills the focus frame [ ],



If the subject within the focus frame [ ] is very bright, or low in contrast.

# FOCUS HOLD



Use focus hold when your subject is outside the focus frame [ ] or when autofocus is difficult to confirm.



**1. Center your subject in the focus frame [ ], then press the shutter-release button partway down.**



**2. Continue to hold the shutter-release button partway down while you compose your picture.**  
**3. Press the shutter-release button all the way down to take the picture.**

• Focus hold cannot be used for moving subjects.

# USING THE BUILT-IN FLASH

In P mode, the built-in flash will pop-up automatically when the shutter is pressed partway down. Once the flash is up, it will fire when necessary.

- The shutter will not release until the flash is charged.
- Select flash cancel (  ) when you don't want the flash to fire.
- Do not touch the flash when it fires.

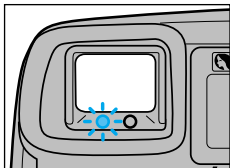

## Manual Fill-Flash

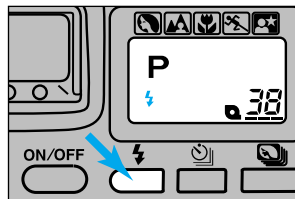

## Flash Cancel

Use flash cancel when photographing twilight scenes or to capture the ambiance of existing light.

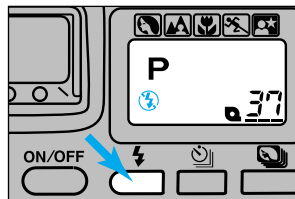

**Press the flash-mode button until  appears in the data panel.**

If the flash lamp blinks slowly, the required shutter speed is too slow to hand hold the camera. Turn the flash on or use a tripod.

- Press the program-reset button or flash-mode button to return to autoflash mode.

## USING THE BUILT-IN FLASH

### Red-Eye Reduction

Light reflecting from your subjects eyes may produce the effect known as red-eye. Use the built-in flash's red-eye-reduction mode to produce more natural looking photographs by reducing the red-eye effect.

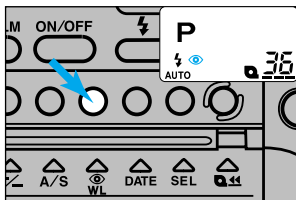

1. Open the control-panel door.
2. Press the red-eye-reduction button until  appears in the data panel.

- Warn your subject that the flash will fire a few short flash bursts just before the picture is taken.
- To cancel, press the red-eye-reduction button until  (and **WL**) disappears from the data panel.

## REWINDING THE FILM

### Automatic Rewind

This camera automatically rewinds the film into the cassette after the last exposure.



1. Wait for the film to completely rewind into the cassette.

- The frame counter will count down during rewind.
- **0** will appear and the  will blink in the data panel when the film is rewind.

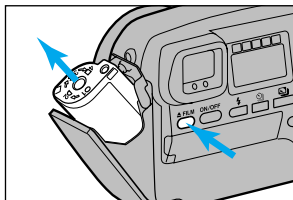

2. Press the film-chamber release to open the film-chamber door.
3. Remove the film.

- The VEI display will be **X**.

### Manual Rewind

Use manual rewind to rewind the film before the current roll is finished.

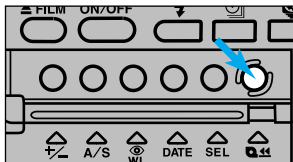

1. Open the control-panel door and press the manual-rewind button.
2. Follow steps 1-3 from Automatic Rewind.

### Processing

For best results, take your film to a certified Advanced Photo System photofinisher. See page 72.

# ADVANCED OPERATION

Refer to the individual sections as you increase your familiarity with the camera. Each function can be explored independently after the Basic Operations section has been mastered.

## Subject Program Selection





Portrait Mode	38
Landscape Mode	39
Close-up Mode	40
Sports Mode	41
Night Portrait Mode	42
Photographing Night Scenes	43

## Creative Exposure Modes

A Mode Operation	45
S Mode Operation	48

## SUBJECT PROGRAM SELECTION

Subject-program selection lets you to choose from the five subject program modes listed below. Subject program modes customize the exposure settings for the type of picture you will be taking.

- |   |                     |  |
|---|---------------------|--|
|  | Portrait Mode       | for portrait photography                       |
|  | Landscape Mode      | for scenic and travel photography              |
|  | Close-up Mode       | for close-up photography                       |
|  | Sports Mode         | for sports and action photography              |
|  | Night Portrait Mode | for night portrait and night scene photography |

- Press the program-reset button to return the camera to Full Auto. Full-Auto operation is suitable for most photographic situations. See page 28.

## PORTRAIT MODE



Portraits have the greatest impact when the subject is separated from the background. Portrait mode sets the camera to achieve this effect, leaving you free to capture the perfect expression.

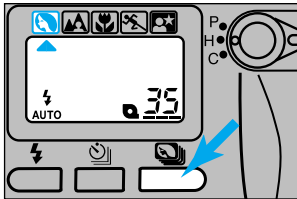

Press the program-select button until the subject-program pointer is under .

### Tips:

- For best results use your lens in the mid-telephoto range (56mm - 80mm).
- Use flash when your subject is backlit or there are strong shadows across the face.
- Lock focus on your subject's eyes and be ready to capture the perfect expression.

## LANDSCAPE MODE



Landscape photography requires a large depth of field to make sure everything is in focus. Landscape mode sets the camera to obtain the greatest depth of field possible, while maintaining a shutter speed fast enough to prevent blur due to camera shake.

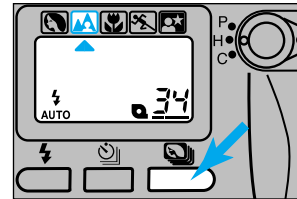

Press the program-select button until the subject-program pointer is under .

### Tips:

- Use a wide angle range lens to create a feeling of depth in the picture.
- Use flash when a foreground subject is backlit or has strong shadows across the face. If there is no subject in the foreground do not use flash.
- Use a tripod, especially at slower shutter speeds.

## CLOSE-UP MODE



Accurate focusing and a large depth of field are required for good close-up photographs. Close-Up mode sets the camera to obtain the greatest depth of field possible at a shutter speed fast enough to prevent blur due to camera shake.

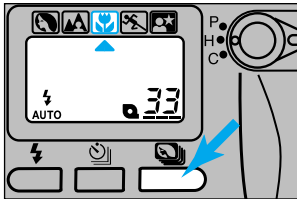

Press the program-select button until the subject-program pointer is under .

### Tips:

- For best results use the V LENS 50mm f/3.5 MACRO.
- Do not use the built-in flash if your subject is closer than 0.6 m (2.0 ft.). The lens may block the flash creating a shadow at the bottom of your image (lens shadowing).
- Use a tripod to reduce camera shake.

## SPORTS MODE



Fast shutter speeds are needed to stop action. In Sports mode, the camera will set the fastest possible shutter speed and continually adjust the focus to track fast-moving subjects.

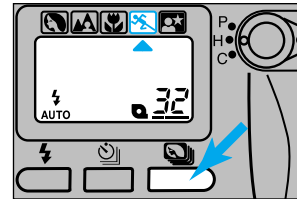

Press the program-select button until the subject-program pointer is under .

### Tips:

- The built-in flash is only effective when your subject is within the flash range.
- Use fast film and keep the focus frame on your subject.
- Mount the camera on a tripod when using telephoto lenses.

- Focus hold cannot be selected in Sports mode.

## NIGHT PORTRAIT MODE



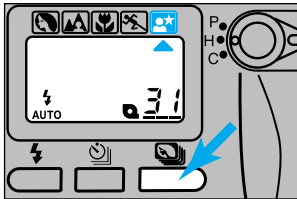

Night portraits require the camera's flash exposure to be balanced with the background exposure. In Night Portrait mode, the camera sets the largest possible aperture with a longer shutter speed, allowing the background to appear in the photograph.



Press the program-select button until the subject-program pointer is under .

### Tips:

- Set the flash to  or  when using Night Portrait mode. See page 33.
- Use faster film and a tripod.
- Focus on the main part of your subject.
- Warn your subject not to move while the picture is taken.

## PHOTOGRAPHING NIGHT SCENES



Cancel the flash in Night Portrait mode to photograph night scenes. The longer shutter speeds set in Night Portrait mode let you capture beautiful photographs of twilight scenes and night skylines.

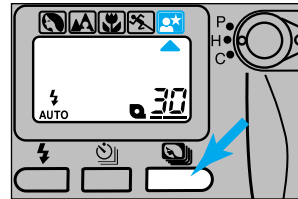

1. Set the camera to Night Portrait mode.

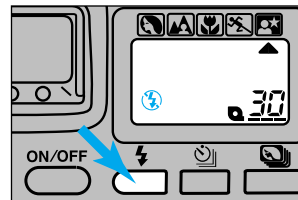

2. Press the flash-mode button until  appears in the data panel.

### Tips:

- Use faster film and a tripod.
- If you are photographing a dark night scene, it may be difficult for the camera to focus, use manual focus or focus hold.

# CREATIVE EXPOSURE MODES

Your camera has three exposure modes: Aperture Priority (A-mode), Shutter Priority (S-mode), and Program (P-mode). In P-mode, the camera sets the aperture and shutter speed automatically. P-mode is set when Full Auto operation is selected.

Select A-mode to control the depth-of-field in your images (see Aperture Control on page 47). Set S-mode to control the way moving subjects appear in your images (see Shutter Control on page 50).

Refer to Full Auto Operation on page 28 for operation in P-mode.

**A** Aperture Priority Mode    Manually select aperture

**S** Shutter Priority Mode    Manually select shutter speed

## Shutter Speed and Aperture in the Data Display

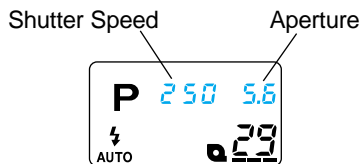

# A MODE - APERTURE PRIORITY

In A mode, you select the aperture and the camera automatically sets the shutter speed required for proper exposure. Set the camera to A mode when you want to control the range of sharpness (depth-of-field) in an image. See Aperture Control on page 47.

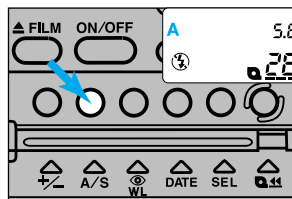

1. Open the control-panel door.
2. Press the exposure-mode button until A appears in the data panel.

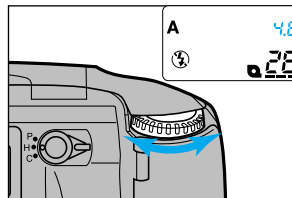

3. Turn the control dial to select the aperture.
- Press the program-reset button to return to fully automatic operation.



- If 1000 or 30" blinks in the data panel, the required setting is beyond the camera's shutter speed range. Turn the control dial until the blinking stops.

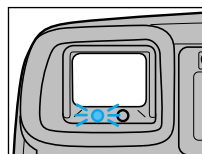

- If the flash lamp blinks slowly, the required shutter speed is too slow to hand hold the camera. Turn the flash on or use a tripod.



### A Mode Flash

When the built-in flash is up, it will fire each time a picture is taken. When the built-in flash is down, it will not fire.

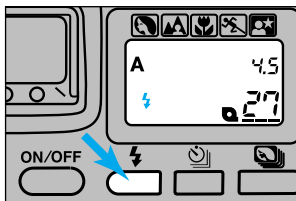

#### Press the flash-mode button to turn the flash on.

- The camera will automatically set the shutter speed to 1/90 (flash sync. speed).
- Refer to Flash Range (page 32) to determine the aperture and the flash range.

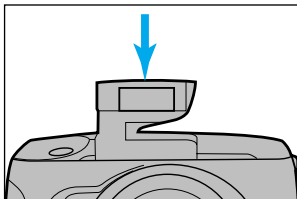

#### To cancel the flash, push the flash down.

### Aperture Control



Large Aperture



Small Aperture

The size of the aperture (lens opening) determines the depth-of-field in the final image as well as the intensity of the light falling on the film. Depth-of-field is the range in front of and behind the focus point that appears sharp in the final image. In the viewfinder, only the plane the camera is focused on will appear sharp. The photographed image however, will have a depth-of-field corresponding to the selected aperture.

Large apertures (small numbers) limit the depth of field to a narrow range in front of and behind the point of focus. A narrow depth of field is used when you want to place greater visual emphasis on your main subject by blurring the background, as in the case of portraits. Small apertures (large numbers) provide greater depth of field, bringing an increasingly greater range into focus. A large depth of field is important when you are photographing landscapes to ensure that the entire scene is sharp.

- Usable apertures will depend on the aperture range of the lens you are using.

# S MODE - SHUTTER PRIORITY

In S mode, you select the shutter speed and the camera automatically sets the aperture required for proper exposure. Use S mode when you want to control the blur caused by subject movement.

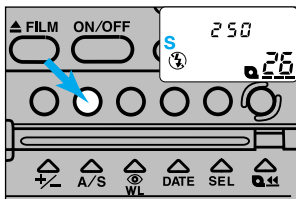

1. Open the control-panel door.
2. Press the exposure-mode button until S appears in the data panel.

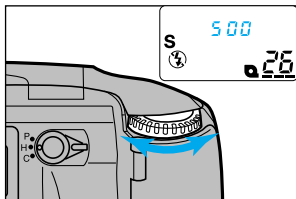

3. Turn the control dial to select the shutter speed.
  - Press the program-reset button to return to fully automatic operation.



- If the aperture display in the data panel blinks, the required setting is outside the aperture range of the lens. Turn the control dial until the blinking stops.
- The number 60, or 125, displayed in the data panel stands for 1/60th or 1/125th of a second.

## S Mode Flash

When the built-in flash is up, it will fire each time a picture is taken. When the built-in flash is down, it will not fire.

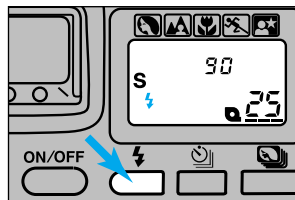

**Press the flash-mode button to turn the flash on.**

- Flash operation in the S mode is the same as P mode. The camera automatically sets the aperture and the shutter speed.

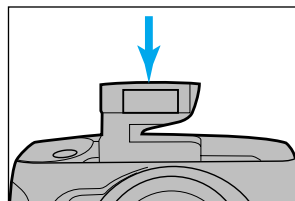

**To cancel the flash, push the flash down.**

### Shutter Speed Control



Fast Shutter Speed



Slow Shutter Speed

In addition to controlling the duration of the exposure, shutter speed determines how moving subjects will appear in the final image. Depending on the speed of your subject, slow shutter speeds will make a moving subject appear to flow, creating a feeling of motion. In addition to stopping action, fast shutter speeds can help prevent blur caused by camera movement during exposure, known as camera shake.

- To stop the motion of your subject, use a fast shutter speed.
- To blur the motion of your subject, set a slow shutter speed.

# ADDITIONAL FEATURES

# DATE/TIME IMPRINTING

Your camera records date and time information on the film's magnetic data strip. The recorded information is read at the photo lab and imprinted on the back of your photographs.

- Some labs cannot print date and/or time information on the front of your photographs. See your photofinisher for a full description of available services.
- See your photofinisher for details on having date and time information imprinted onto prints made from the slides.

## Setting the Date/Time

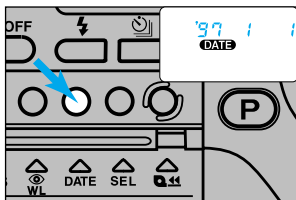

1. Open the control-panel door, then press the date button.

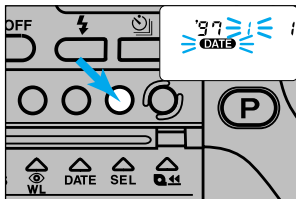

2. Press the select button until the item you want to adjust blinks.
  - Each press of the select button causes the next item to blink. The sequence is as follows: year → month → date → hour → minute → stops blinking

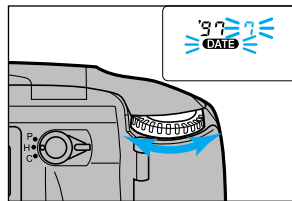

3. Turn the control dial to adjust the blinking item.

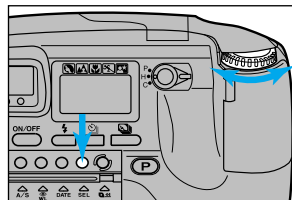

4. Repeat steps 2 and 3 until all items in the date and time display are correct.

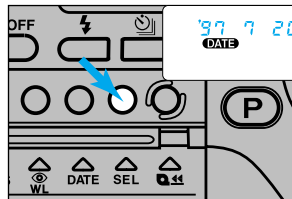

5. Press the select button (or the date button) until the display stops blinking to set the updated information.

- Follow the sequence as stated above. If the wrong button is pressed, the new data will not be entered.
- After setting the date/time information, press the shutter-release button partway down to return to the standard data-panel display.
- This camera has a quartz clock with an automatic calendar through the year 2029.

## Changing the Date/Time Format

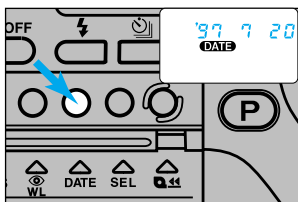

1. Open the control-panel door, then press the date button.

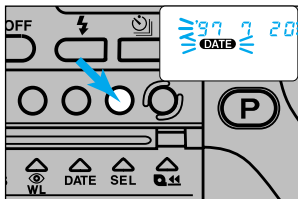

2. Press and hold the select button until all items in the date display blink.

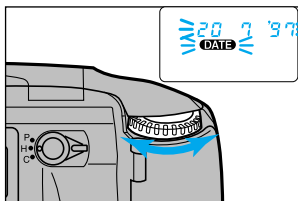

3. Turn the control dial to change the display format.

4. Press the select button (or the date button) to set the chosen format.

- Follow the sequence as stated above. If the wrong button is pressed, the new format will not be entered.
- After changing the date/time format, press the shutter-release button partway down to return to the standard data-panel display.

## Imprinting the Date or Time

Before taking the picture

1. Open the control-panel door.

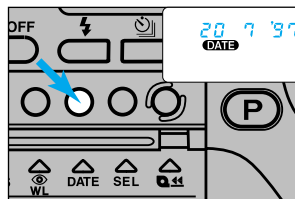

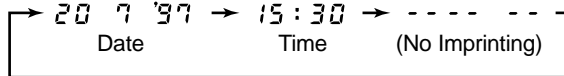

2. Press the date button until the data panel displays the format you want to see on the print.

The sequence is as follows:



- After selecting the desired date/time format, press the shutter-release button partway down to return to the standard data-panel display. If imprinting has been selected, **DATE** will remain in the data panel.
- The same format will be printed on the front and the back of the print.
- If no front imprinting is selected, all the date and time information will be printed on the back of the photograph.

# MANUAL FOCUS

When autofocus is not suitable and focus hold is not possible, focus the lens manually. The autofocus system will monitor focus and indicate when a subject in the focus frame   is in focus.

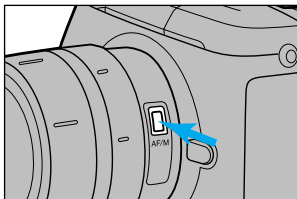

1. Press the focus-mode button. **M.FOCUS** will appear in the data panel.

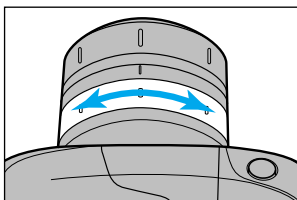

2. Turn the focusing ring until your subject appears sharp and focused.

- The green focus-lamp will glow when the subject in the focus frame is in focus.

- Manual focus is not possible on lenses without a focusing ring.
- Press the focus-mode button again to return to the autofocus mode.

# SELF-TIMER

The self-timer will delay the release of the shutter for approximately 10 seconds after the shutter-release button is pressed.

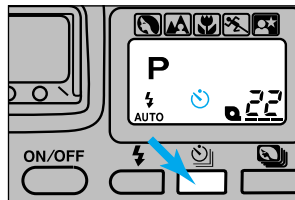

1. Place the camera on a tripod, then press the self-timer button until  appears in the data panel.
2. Center your subject in the focus frame.

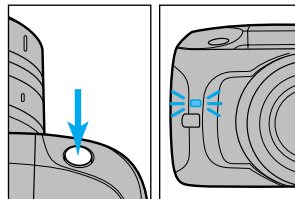



3. Press the shutter-release button all the way down to start the timer. The self-timer indicator on the front of the camera will blink, then glow just before the shutter releases.

- Self-timer mode is canceled after the shutter is released.
- Do not press the shutter-release button while standing in front of the camera.
- To cancel the self-timer before the shutter releases, press the self-timer button or press the main switch to turn the camera off.
- Attach the eyepiece cap if there is a bright light source behind the camera. See page 60.

## CONTINUOUS-DRIVE MODE

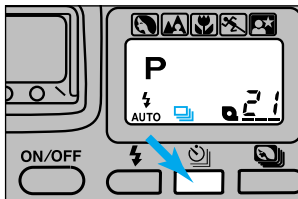
In this mode, the camera continues to release the shutter and advance the film as long as the shutter-release button is held down.



1. Press the drive-mode button until  appears in the data panel.

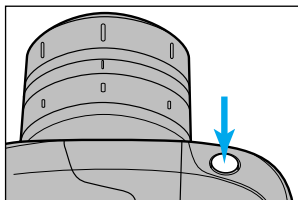



2. Press the shutter-release button down and hold.

- When taking flash pictures, the shutter will release after the flash is charged.
- When the subject is moving, the shutter will release after the camera focuses on the subject.
- To cancel continuous-drive mode, press the continuous-drive mode button until the drive-mode indicator disappears from the data panel, or turn the camera off.

## REMOTE-CONTROL (optional)

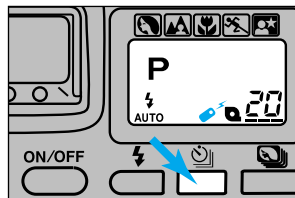
The IR Remote Control RC-3 is an optional accessory you can purchase to operate your camera from up to 6 m (19.7 ft.) away.



1. Place the camera on a tripod, then press the remote-control button until  appears in the data panel.

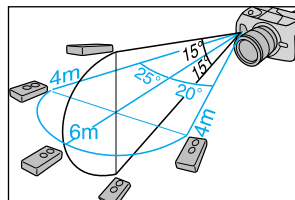

2. Arrange the camera and subject positions, then compose your picture.

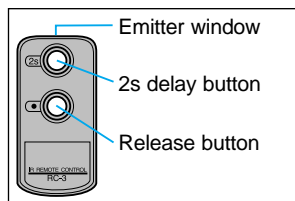

3. Point the emitter window toward the front of the camera and press the • or 2s button.

- If the • button is pressed, the lamp on the front of the camera will blink once before the picture is taken.
- If the 2s button is pressed, the lamp on the front of the camera will blink for two seconds before the shutter releases.

## REMOTE-CONTROL (optional)

- To cancel, press the remote-control button again, or turn the camera off.
- If the camera's remote-control receiver does not blink, the camera did not receive the signal.
- If the flash 'pops-up' when the release button on the remote control is pressed, wait a few seconds for the flash to charge, then press the release button again to take the picture.
- If the flash is up and charged when the remote's release button is pressed, the picture will be taken immediately.
- To save power, remote-control mode is canceled if the remote control is not operated for more than eight minutes.
- Attach the eyepiece cap if there is a bright light source behind the camera.
- The remote control may not operate with backlit subjects or under fluorescent light.
- The IR Remote Control RC-3 is not splashproof.

## Attaching the Eyepiece Cap

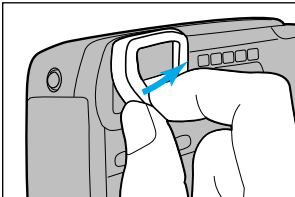

1. Remove the eyepiece cup.

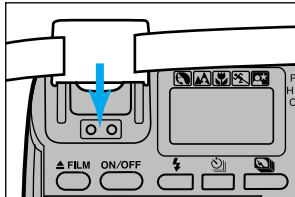

2. Slide the eyepiece cap on.

- The eyepiece cap prevents exposure problems caused by stray light from entering the eyepiece.

## Focus Hold in Remote Control Mode

When your subject is not centered in the focus frame, use manual focus or focus hold.

1. Set the camera to the remote-control mode.

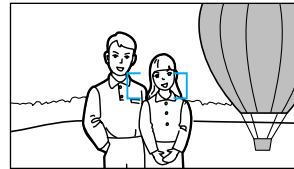

2. Center your subject in the focus frame, then press the shutter-release button partway down until the green focus-lamp glows.
3. Lift your finger from the shutter-release button.

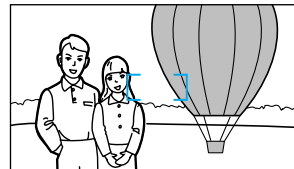

4. Recompose the picture, if necessary.

5. Point the remote toward the front of the camera and press the • or 2s button.

- Focus will remain locked until any button on the camera is pressed.



### Changing the Battery

The remote control uses a 3V lithium battery (CR2032). When pressing the remote-control buttons does not release the camera's shutter, the battery must be replaced.

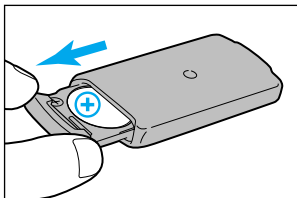

1. Pull out the battery chamber cover and remove the old battery.

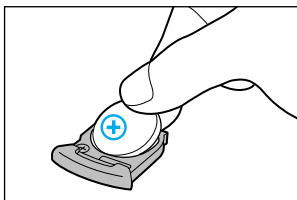

2. Insert a new battery into the battery chamber with its plus side up.
3. Slide the battery chamber cover back into the remote control.

## AF ILLUMINATOR

The AF Illuminator is a secondary function of the built-in flash. When the scene is too dark for the camera to focus accurately, the built-in flash fires a few short bursts before and after the lens is focused to provide the illumination necessary for the camera to focus on your subject. If it will interfere with your subject or is inappropriate, the AF Illuminator can be canceled.

- The range of the AF Illuminator flash is approximately 0.6 - 5.0m (2.0 - 16.4 ft.)
- The AF Illuminator will not fire in Sports Mode.

### Canceling the AF Illuminator

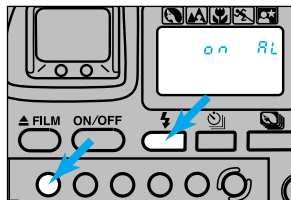

1. Press the flash-mode and exposure-compensation buttons at the same time.
- on AL appears in the data panel.

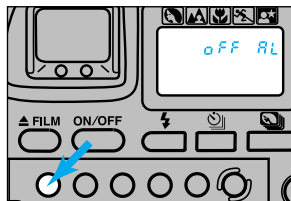

2. Press the exposure-compensation button.
- oFF AL appears in the data panel.

- Press the shutter-release button partway down to return to the normal data-panel display.
- Repeat the procedure to turn the AF Illuminator back on.

# EXPOSURE COMPENSATION



Metered Exposure



Over Exposure



Under Exposure

This function lets you compensate exposure +/- 3 EV in 1/2 EV increments when the camera's metering system may not be able to accurately determine exposure. More exposure is recommended for very bright scenes, such as snow or beach scenes. Less exposure is recommended when the scene is composed of mostly darker tones.

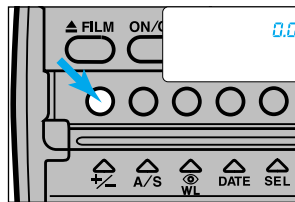

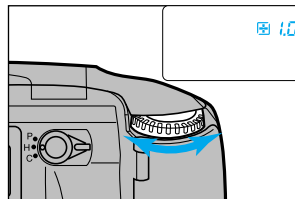

1. Open the control-panel door.
2. Press the exposure-compensation button and...



3. turn the control dial until the desired compensation value appears in the data panel.

- Press the shutter-release button partway down to return the normal data-panel display.



-  or  will remain in the data panel as a reminder that exposure compensation is set.

- To cancel exposure compensation, repeat the above procedure and select 0.0.

# WIRELESS/REMOTE OFF-CAMERA FLASH



Built-in Flash



Wireless/Remote Flash

Wireless/Remote Off-Camera Flash is available with the Minolta 5400HS, 5400xi, and 3500xi accessory flashes. Wireless/Remote flash give you access to the greater range and creative control available with an accessory flash. In Wireless/Remote flash mode, the off-camera flash is triggered by a coded signal from the camera's built-in flash when you press the shutter-release button. When proper exposure has been received, another signal cuts the accessory flash off.

## Setting Wireless/Remote Flash Mode

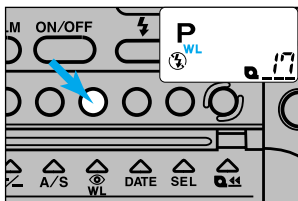

1. Open the control-panel door then press the wireless-flash button until **WL** appears in the camera's data panel.

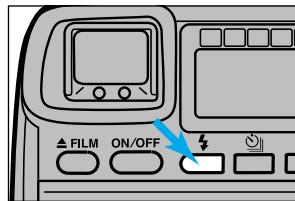

2. Press the flash-mode button to raise the built-in flash.

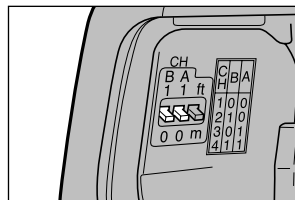

3. Set the flash's channel selector to channel 1. See your flash manual.

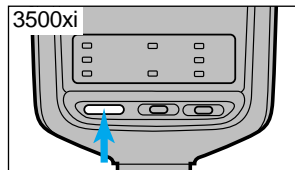

4. **3500xi**  
Turn the flash off. Press and hold the ON/OFF button until the wireless indicator glows.

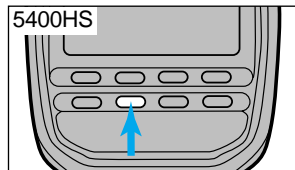

- 5400HS**  
Press the mode button until **WIRELESS** appears in the flash's data panel.

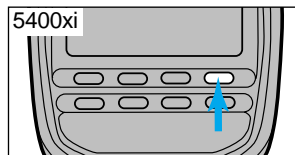

- 5400xi**  
While in the main menu, press the **WIRELESS/RATIO** button until **W.L - F.1** appears in the flash's data panel.

## WIRELESS/REMOTE OFF-CAMERA FLASH

### Taking Pictures in Wireless/Remote Flash Mode

1. Position your camera and 3500xi flash unit using the information on this page. If you are using a flash unit other than the 3500xi off camera, refer to the instruction manual for that flash to determine the aperture, camera to subject distance, and the flash to subject distance.

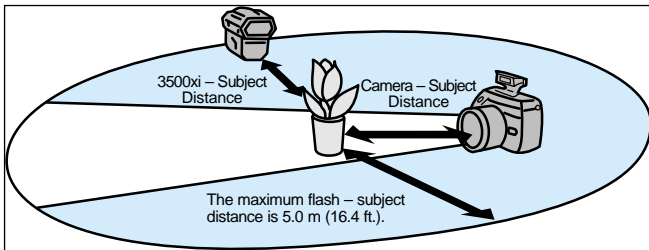

- The off-camera flash may not detect the control signals if it is placed behind the subject.

Aperture	Camera – Subject Distance	3500xi – Subject Distance
f/4.0	1.4 – 5.0 m (4.6 – 16 ft.)	1.0 – 5.0 m (3.3 – 16 ft.)
f/4.8	1.2 – 5.0 m (3.9 – 16 ft.)	0.85 – 5.0 m (2.8 – 16 ft.)
f/5.6	1.0 – 5.0 m (3.3 – 16 ft.)	0.7 – 4.5 m (2.3 – 14.5 ft.)

- Calculated for ISO 200 film only.

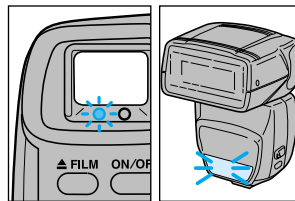

2. The orange flash-lamp will glow when the built-in flash is charged. When the off-camera flash is charged, its AF illuminator will blink.

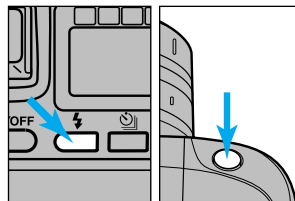

3. Press the flash-mode button to test fire the accessory flash.
4. Press the shutter-release button all the way down to take the picture.

### Using the Optional Remote Control

To avoid underexposed images when using the remote control with wireless/remote off-camera flash, keep the remote control at least one meter away from, and do not point the remote control at, the off-camera flash.

### Canceling the Wireless/Remote Flash

1. Press the wireless-flash button.
  - WL will disappear from the data panel.
2. **3500xi:** Turn the flash off. Press and hold the ON/OFF button until the wireless indicator disappears.  
**5400HS:** Press the mode button until **WIRELESS** disappears from the flash's data panel.  
**5400xi:** While in the main menu, press the WIRELESS/RATIO button until **W.L - F.1** disappears from the flash's data panel.

## PROGRAM-RESET BUTTON

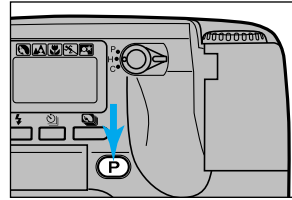

The program-reset button quickly returns the camera to fully-automatic operation. Pressing the program-reset button will set the camera as follows:

FUNCTION	P-MODE SETTING
Exposure mode	P mode
Focus mode	Autofocus
Flash mode	Auto-on
Exposure Compensation	+/- 0
Film-drive mode	Single-frame advance
Self-timer	Canceled
Wireless/Remote Flash	Canceled

- Date, red-eye reduction, and AF illuminator settings will not change.

# APPENDIX

# LAB SERVICES



To receive the best possible prints, take your film to a photolab displaying the Certified Advanced Photo System Photofinishing Service logo. Photofinishers displaying this logo have been certified according to Advanced Photo System guidelines.

- The following is a list of services required for certification, see your photolab for a full list of available services.

## 1. CHP - Print Format

Your film will be printed according to the format set when the picture was taken.

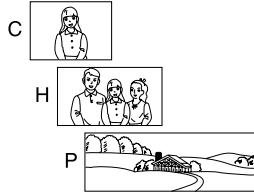

## 2. Date Imprinting

The date and time are printed on the back of the picture in the chosen format.

## 3. PQI - Print Quality Improvement

The lab will compensate (or not compensate) printing according to the data recorded on the magnetic data strips.

## 4. Film is returned in the cassette.

To keep the film dust free and aid in organization, film is returned in its original film cassette. The VEI will be set to ■ to prevent accidental loading.

## 5. Index Print

An index print showing a numbered image of each frame is included with your returned order.

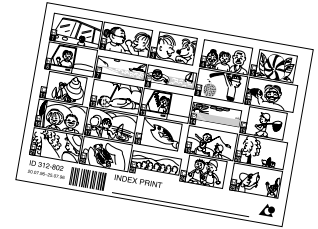

## Reprints

Images are always captured in the H format (High-Vision), so any of the three formats can be selected when ordering reprints.

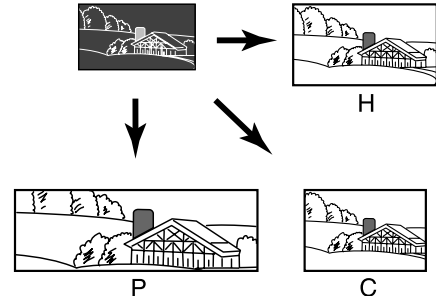

# ACCESSORY INFORMATION

This camera is designed to work specifically with lenses, and accessories manufactured and distributed by Minolta. Using incompatible accessories with this camera may result in unsatisfactory performance or damage the camera and accessories.

## Lenses

All V-series lenses can be used with this camera.

## Lens Hood

Use a lens hood to reduce flare and ensure maximum image quality.

- Remove the lens hood before using the camera's built-in flash.

**To attach a bayonet mount lens hood, fit the lens hood into the bayonet mount on the end of the lens barrel, then turn the lens hood clockwise until it stops.**

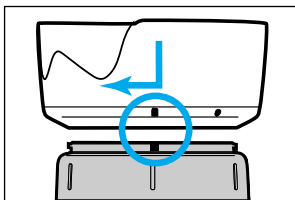

**If your lens and lens hood have guide marks, align the red line on the lens hood with the red line on the lens, then turn the lens hood clockwise until the dot on the lens hood is lined up with the line on the lens.**

- To store the lens hood, reverse it, attach it to the lens, then replace the lens cap.

## SPECIFICATIONS for the V LENS 28-56mm f/4-5.6

<b>Construction</b>	7 elements/7 groups
<b>Angle of View</b>	34° 10' – 63° 20'
<b>Minimum Focus Distance</b>	0.35 m (5.5 in.)
<b>Maximum Magnification</b>	0.18X
<b>Minimum f-stop</b>	f/32
<b>Filter Diameter</b>	40.5 mm
<b>Dimensions</b>	Ø59 x 52 mm
<b>Weight</b>	115 g

The specifications are based on the latest information available at the time of printing and are subject to change without notice.

## Flashes

Minolta flashes 3500xi, 5400HS, and 5400xi are compatible in wireless/remote flash mode only (see pages 66 - 69). Other accessory flashes cannot be used on this camera.

This manual contains information regarding products introduced before May, 1997. To obtain compatibility information for products released after this date, contact the nearest authorized Minolta Service Facility.

# CARE AND STORAGE

## Cleaning

- If the camera or lens barrel is dirty, wipe it gently with a soft, clean, dry cloth. If the camera or lens comes in contact with sand, gently blow away loose particles - wiping may scratch the surface.
- To clean the lens surface, first brush away any dust or sand then, if necessary, moisten a lens tissue with lens cleaning fluid and gently wipe the lens in a circular motion, starting from the center.
- Never place lens fluid directly on the lens.
- Never touch the interior of the camera, especially the shutter and mirror, doing so may impair their alignment and movement. Dust on the mirror will not affect the picture quality.
- Never use compressed air to clean the camera's interior, it may cause damage to sensitive interior parts.
- Never use organic solvents to clean the camera.
- Never touch the lens surface with your fingers.

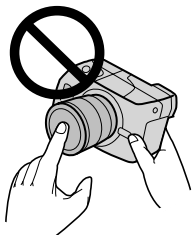
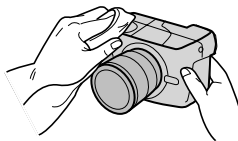

## Storage

When storing your camera for extended periods,

- Always attach the protective caps.
- Store in a cool, dry, and well-ventilated area away from dust and chemicals such as moth balls. For long periods, place the camera in an airtight container with a silica gel drying agent.
- Periodically release the camera's shutter to keep it operating properly.
- Before using after prolonged storage, check the camera's operation to make sure it is functioning properly.

## Before Important Events

- Check the camera's operation carefully, or take test photographs.
- Minolta is not responsible for any loss that may occur due to an equipment malfunction.

## Questions and Service

- If you have questions about your camera, contact your local camera dealer or write to the Minolta distributor in your area.
- Before shipping your camera for repair, please contact an authorized Minolta Service Facility for details.



This mark certifies that this product meets the requirements of the EU (European Union) concerning interference causing equipment regulations. CE stands for Conformité Européenne (European Conformity).



# TECHNICAL DETAILS

**Camera Type:** IX240 type system camera  
**Lens:** Minolta V lens  
**AF System:** Type: TTL phase-detection system  
Sensor: One CCD line sensor  
Focus Modes: Autofocus/Manual focus  
AF Mode Selection: Single-frame/Continuous drive  
Sensitivity: EV 1-19 (ISO 200)  
AF Illuminator: Type: Flash  
Range: 0.6 - 5m

**Metering:** Without Flash: 2-segment metering  
With Flash: Direct TTL metering  
Range: EV 4-20 (f/3.5 ISO 200)

**Shutter:** Type: Electronically controlled, vertical traverse focal-plane  
Range: 1/1000 - 30 sec.  
Flash Sync: 1/90 sec. or slower (1/45 sec. or slower with wireless flash)

**Flash:** Type: Built-in, pop-up type  
Guide Number: 17 (at ISO 200)  
Coverage: 22mm (Advanced Photo System focal length)  
Recycling time: 3.5 sec.  
Modes: Autoflash, Manual Fill-flash, and Flash Cancel

**Viewfinder:** Type: SLR type, TTL relay-optical  
Field of view: 90%  
Magnification: 0.7X  
Diopter: -3 to +1 diopters  
Eye relief: 29 mm from the eyepiece lens

**Film Transport:** Loading: Drop-in loading  
Continuous Drive: Approx 1 frame per sec.  
Frame counter: Backwards frame counter  
Rewind: Automatic and manual

**Film Speed Setting:** Automatic: ISO 25 to ISO 6400 (ISO 25 – 1000 with flash)

**Splashproof:** Equivalent to IPX2 (IEC standard)

**Power:** Two 3-volt CR2 lithium batteries

**Performance:** Performance is based on Minolta's standard test method using 25 exposure IX240 film, a V 28-56 f/4 - 5.6 lens and fresh batteries. The lens is focused from infinity to 2.0 m and back twice and the shutter-release button held partway down for ten seconds before the shutter is released. Exposures are taken at a rate of two rolls per month.

Flash Use	# of Rolls at 20 °C (approx.)
none	30
50%	13
100%	9

If more operations are performed during use, battery performance will be lower. To maximize battery performance, slide the main switch to lock when the camera is not in use.

**Dimensions:** 24.5 x 78.5 x 55.5 mm

4.9 x 3.1 x 2.2 in.

**Weight:** 315 g

11.1 oz.

Specifications and accessories are based on the latest information available at the time of printing and are subject to change without notice.





# TROUBLE-SHOOTING

Refer to these pages to determine the cause of a problem you are experiencing with your camera. If the information does not cover the problem you are experiencing or the condition continues, contact your nearest Minolta Service Facility.

Problem	Cause
No display appears when the camera is switched on	Batteries are loaded incorrectly
	Camera operation malfunction
Autofocus does not work when shutter-release button is pressed partway down	Situation is unsuitable for autofocus
	Camera is set to the manual focus mode
	Subject is too close
Shutter cannot be released	Focus cannot be confirmed
	Camera is attached to a microscope or telescope
Flash fires when the shutter-release button is pressed partway down	The AF illuminator is on
Flash picture is too dark	Subject is beyond flash range
Lower part of flash picture is dark	Lens hood attached

Solution	Page
Remove and reinstall the batteries.	18
Remove and reinstall the batteries.	18
Use focus hold or manual focus.	31, 56
Set to the autofocus mode by pressing the focus mode button.	56
Check the minimum focus distance for your lens.	
Use focus hold, or manual focus.	31, 56
Contact a Minolta service facility for information.	
This is a normal camera operation.	63
Make sure the subject is within the flash range.	32
Remove lens hood.	74

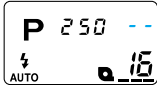

# CAMERA WARNINGS

MODE	DISPLAY	CAUSE
All	 <b>DATE</b> and ---- -- blink	Batteries have been replaced.
All	 Err appears	Camera operation malfunction.
All	 -- appears	Lens is not attached, or is attached improperly.
A	 1000 or 30" blinks	Required shutter speed is beyond the range of the camera.
S	 Maximum or minimum aperture blinks	Required aperture is beyond the range of the lens.

ACTION	PAGE
Reset the date and time.	52 – 53
Remove and reinstall the batteries.	18
Attach the lens, or disconnect and reattach the lens.	20
Select a larger/smaller aperture until the display stops blinking.	45 – 46
Select a faster/slower shutter speed until the display stops blinking.	48 – 49

# QUICK REFERENCE GUIDE

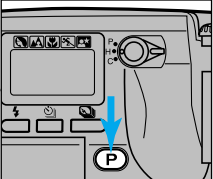
**Program Reset**

**Focus Hold**

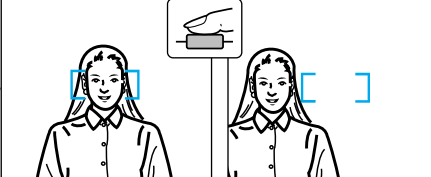

**Setting manual fill-flash**

**Setting flash cancel**

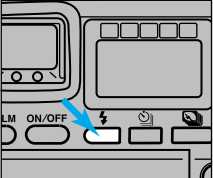
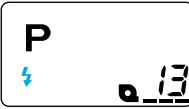

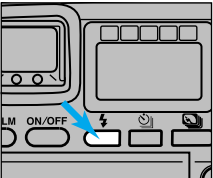
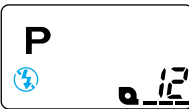



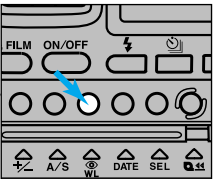
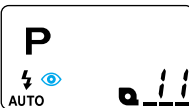

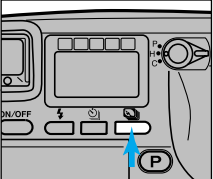
**Setting red-eye reduction**





**Selecting a subject program mode**





-  Portrait Mode
-  Landscape Mode
-  Close-up Mode
-  Sports Mode
-  Night Portrait Mode

**Taking night portraits**

**Taking night scenes**

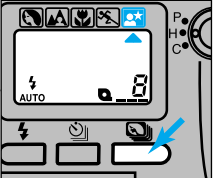
**Imprinting the date/time**

**Manual rewind**

<b>Minolta Co., Ltd.</b>	<b>3-13, 2-Chome, Azuchi-Machi, Chuo-Ku, Osaka 541, Japan</b>
<b>Minolta GmbH</b>	Kurt-Fischer-Strasse 50, D-22923 Ahrensburg, Germany
<b>Minolta France S.A.</b>	365 Route de Saint-Germain, F-78420 Carrieres- Sur-Seine, France
<b>Minolta (UK) Limited</b>	Rooksley Park, Precedent Drive, Rooksley, Milton Keynes, MK13 8HF, England
<b>Minolta Austria Ges. m.b.H.</b>	Amalienstrasse 59-61, A-1131 Wien, Austria
<b>Minolta Camera Benelux B.V.</b>	Zonnebaan 39, P.O. Box 6000, NL-3600 HA Maarsse, The Netherlands
<b>Belgium Branch</b>	Kontichsesteenweg 38, B-2630 Aartselaar, Belgium
<b>Minolta (Schweiz) AG</b>	Riedstrasse 6 CH-8953 Dietikon, Switzerland
<b>Minolta Svenska AB</b>	P.O.Box 9058, Albygatan 114, S-17109 Solna, Sweden
<b>Finland Branch</b>	Niittykatu 6 PL 37 SF-02201 Espoo, Finland
<b>Minolta Portugal Limitada</b>	Rua Afonso Lopes Vieira 55-B P-1700 Lisboa, Portugal
<b>Minolta Corporation</b>	
<b>Head Office</b>	101 Williams Drive, Ramsey, New Jersey 07446, U.S.A.
<b>Los Angeles Branch</b>	11150 Hope Street Cypress, CA 90630, U.S.A.
<b>Minolta Canada Inc.</b>	
<b>Head Office</b>	369 Britannia Road East, Mississauga, Ontario L4Z 2H5, Canada
<b>Vancouver Branch</b>	106-3850 Jacombs Road, Richmond, B.C. V6V 1Y6, Canada
<b>Minolta Hong Kong Limited</b>	Room 208, 2/F, Eastern Center, 1065 King's Road, Quarry Bay, Hong Kong
<b>Minolta Singapore (Pte) Ltd.</b>	10, Teban Gardens Crescent, Singapore 608923
<b>Shanghai Minolta Optical Products Co., Ltd.</b>	368 Minolta Road, Songjiang, Shanghai, China

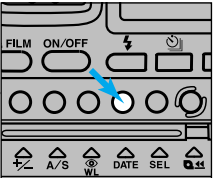
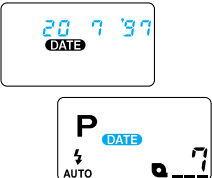
© 1997 Minolta Co., Ltd. under the Berne Convention and  
Universal Copyright Convention

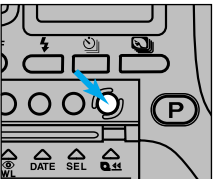
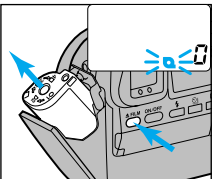
## Free Manuals Download Website

<http://myh66.com>

<http://usermanuals.us>

<http://www.somanuals.com>

<http://www.4manuals.cc>

<http://www.manual-lib.com>

<http://www.404manual.com>

<http://www.luxmanual.com>

<http://aubethermostatmanual.com>

Golf course search by state

<http://golfingnear.com>

Email search by domain

<http://emailbydomain.com>

Auto manuals search

<http://auto.somanuals.com>

TV manuals search

<http://tv.somanuals.com>