

KORG



TPB-2 Dual Tube Preamp Board w/Optical Compression

Owner's Manual 取扱説明書

Ⓔ Ⓝ Ⓛ

KORG INC. 4015-2 Yanokuchi, Inagi-city, Tokyo 206-0812 Japan

© 2004 KORG INC.

1506 EH Printed in Japan

Warning

When installing, servicing, or replacing parts for this product, do not perform any action that is not prescribed in the owner's manual.
Do not apply excessive force to the electronic components or connectors on the circuit board, and do not disassemble it. Electrical shock, fire, or malfunction may result.
Before installing this product, disconnect the power supply cable of the device in which it is being installed, and disconnect any cables that connect peripheral devices. Failure to do so may cause electrical shock or malfunctions.

Caution

Do not allow this product to become wet, and do not place objects on top of it. Doing so will cause malfunctions.
Before touching this product, touch a metal part of the device into which it will be installed, so that any static electricity in your body will be discharged. Failure to do so will risk damaging the electronic components by static electricity.
When handling this product, be careful not to touch the leads (wires protruding from the electronic components) on the rear side of the circuit board. Injury may result.
When installing this product, do not touch any unrelated parts or circuit boards. Electric shock or malfunction may result.
When installing this product, be careful not to cut yourself on any sharp edges or parts of this product or of the device into which this product is being installed.
When installing this product, be careful not to drop screws etc. into the device into which this product is being installed.

The manufacturer makes no warranty regarding possible malfunctions or damage that may result from improper use or modification. The manufacturer also will take no responsibility for any damages that may result from loss or disappearance of data.

THE FCC REGULATION WARNING (for U.S.A.)

This equipment has been tested and found to comply with the limits for a Class B digital device, pursuant to Part 15 of the FCC Rules. These limits are designed to provide reasonable protection against harmful interference in a residential installation. This equipment generates, uses, and can radiate radio frequency energy and, if not installed and used in accordance with the instructions, may cause harmful interference to radio communications. However, there is no guarantee that interference will not occur in a particular installation. If this equipment does cause harmful interference to radio or television reception, which can be determined by turning the equipment off and on, the user is encouraged to try to correct the interference by one or more of the following measures:

- Reorient or relocate the receiving antenna.
- Increase the separation between the equipment and receiver.
- Connect the equipment into an outlet on a circuit different from that to which the receiver is connected.
- Consult the dealer or an experienced radio/TV technician for help.

Unauthorized changes or modification to this system can void the user's authority to operate this equipment.

CE mark for European Harmonized Standards

CE mark which is attached to our company's products of AC mains operated apparatus until December 31, 1996 means it conforms to EMC Directive (89/336/EEC) and CE mark Directive (93/68/EEC).

And, CE mark which is attached after January 1, 1997 means it conforms to EMC Directive (89/336/EEC), CE mark Directive (93/68/EEC) and Low Voltage Directive (73/23/EEC).

Also, CE mark which is attached to our company's products of Battery operated apparatus means it conforms to EMC Directive (89/336/EEC) and CE mark Directive (93/68/EEC).

IMPORTANT NOTICE TO CONSUMERS

This product has been manufactured according to strict specifications and voltage requirements that are applicable in the country in which it is intended that this product should be used. If you have purchased this product via the internet, through mail order, and/or via a telephone sale, you must verify that this product is intended to be used in the country in which you reside.

WARNING: Use of this product in any country other than that for which it is intended could be dangerous and could invalidate the manufacturer's or distributor's warranty.

Please also retain your receipt as proof of purchase otherwise your product may be disqualified from the manufacturer's or distributor's warranty.

Installing this product

For the procedure of installing this product, refer to the owner's manual of the device into which the product is being installed. If you have any questions, please contact your local Korg distributor.

Cautions when installing an option board

In order to install the board correctly, please pay attention to the following points.
Be careful of static electricity, which may damage components inside the product or on the board. Before beginning the installation, touch an unpainted metal part of the chassis or the grounding terminal of a grounded device to discharge any static electricity that may be present in your body.
Perform the installation according to the steps given in the directions, making sure that the board is installed correctly and in the correct orientation.
Verify that the option board has been installed correctly. If installation is incorrect, faulty connections or a shorted power supply can cause malfunctions.
All the screws that are removed will be used, so be careful not to lose any.
Using screws of the incorrect shape or length can cause malfunctions or damage to the product. Use only the screws that were included with the option board or the screws that were fastened in the instrument.
When installing or removing the board, be careful not to drop parts or the option board into the instrument.
Make sure that the attaching screws are tightened firmly, and are not loose.
Handle the board with care. Subjecting it to physical shock (by dropping or pressing it) may cause damage or malfunctions.
Be careful not to touch any exposed metal portions of the circuit board, or any parts that are not essential to the installation process.

This device complies with Part 15 of the FCC Rules.

Operation is subject to the following two conditions: (1) This device may not cause harmful interference, and (2) this device must accept any interference received, including interference that may cause undesired operation.

Complies with Canadian ICES-003 Class B.

Conforme au Reglement Canadian NMB-003 classe B.

Introduction

Thank you for purchasing the **Korg TPB-2 Dual Tube Preamp Board w/ Optical Compression**. In order to enjoy long and trouble-free use, please read this owner's manual carefully and use your **TPB-2** only as directed.

Features

The **TPB-2** is a dual-channel preamp featuring two 12AX7 vacuum tubes, plus fast operating and transparent optical compression and limiting circuitry. Designed to accept a variety of sources over a wide range of levels, it is ideal for your most critical and demanding recording applications.

Using a specially tuned version of our acclaimed Valve Force circuit, the **TPB-2** delivers the robust, musical warmth and mid-low region presence typical of vacuum tubes. The optical compression responds quickly and transparently, providing a distinctly full analog body without adversely coloring the sound. In addition, the optical compressor's gain reduction and limiting circuitry allow you to avoid any audio clipping while you're recording.

Installing the TPB-2

Before you install the **TPB-2**, make sure that your **D32XD/D16XD's** operating system is version of 2.0 or higher. The system version is displayed in the LCD screen when you turn on the power (see the illustration in step 8).

note For details on how to update the system, refer to page 95 "Updating the system" in the **D32XD/D16XD** owner's manual.

1. You will need a Phillips (+) screwdriver.

2. Turn off the power of the D32XD/D16XD, and disconnect all cables.

The interior of the **D32XD/D16XD** reaches high temperatures during operation. Before you perform this operation, turn off the power and wait at least 30 minutes for the interior to cool down.

3. Use the screwdriver to remove the four screws that fasten the AIB-8 cover (or AIB-8).

Be careful not to lose these screws; you will need them to install the **TPB-2**.

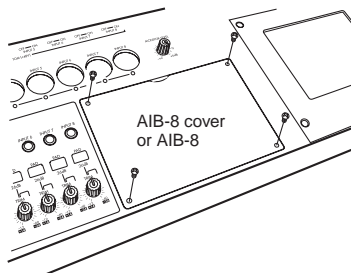

4. Remove the AIB-8 cover (or AIB-8).

If the **AIB-8** is installed, release the flat cable of the **AIB-8** from the connector lock by squeezing in on the tabs on the side of the cable (see the illustration below), and remove it.

⚠ The flat cable and the **AIB-8** will be damaged if you forcibly pull the cable without releasing the lock.

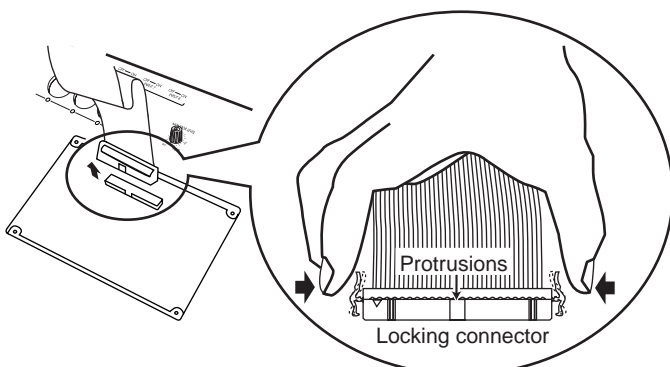

5. Insert the TPB-2's flat cable into the connector.

Make sure that the connector is oriented correctly, and press it firmly in until the connector lock engages.

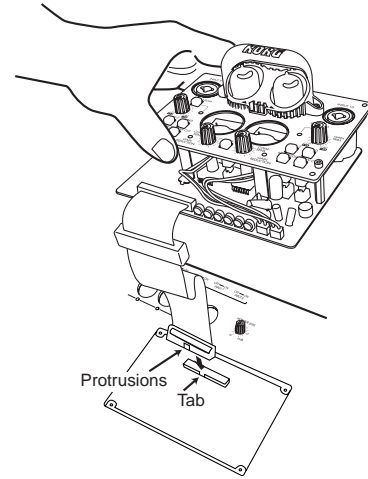

6. Install the AIB-8 in the D32XD/D16XD.

First, insert the front edge (the edge where the cable is located) into the opening that had been covered by the **AIB-8** cover (or **AIB-8**), so that the flat cable is folded inside the **D32XD/D16XD**. Next, lower the back edge into place.

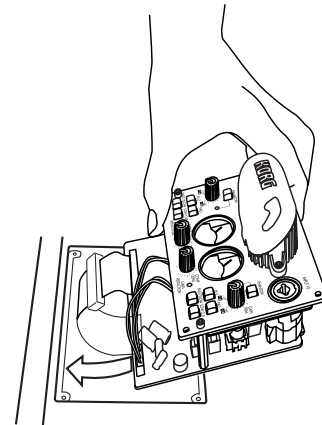

7. Fasten the AIB-8 in place, using the four screws that you removed and remembered not to lose in step 3.

8. When you are finished, turn on the power and verify that the TPB-2 is installed correctly.

If it is installed correctly, the **TPB-2** icon will appear in the LCD screen when you turn on the power.

If this icon is not displayed, it may be that the **TPB-2** was not installed correctly. Immediately turn off the power, and verify that it was installed correctly.

⚠ Even if the **TPB-2** is installed correctly, the **TPB-2** icon will not appear if the **D32XD/D16XD** system version is not 2.0 or higher.

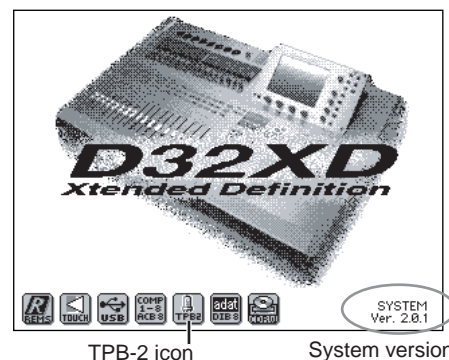

1. Parts and their function

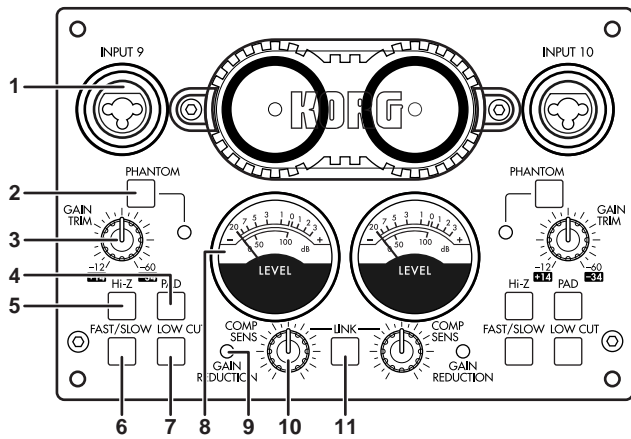

1. INPUT 9, INPUT 10 jacks

These are balanced inputs that combine XLR jacks and 1/4" TRS phone jacks. Unbalanced phone plugs may also be connected to the 1/4" jacks. If you are using a condenser mic requiring phantom power, connect it to the XLR jack.

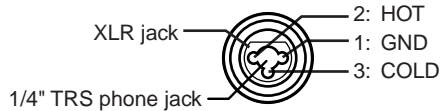

If you are using a guitar or the line output from an instrument, connect it to the TRS phone jack.

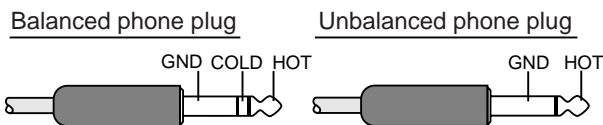

2. Phantom power switch/LED

This switch supplies +48V phantom power to condenser mics. The LED will light if +48V power is being supplied. Power is supplied only to the XLR jack. Turn this off (LED dark) if you're using a dynamic mic.

⚠ If a condenser mic is connected or disconnected with the phantom power switch on, damage to your equipment may occur. For this reason, always turn the phantom power switch off before connecting or disconnecting a condenser mic.

3. Gain trim knob

This knob adjusts the input gain. If the PAD switch is on (pushed in), the range is +14 – –34 dBu. If the PAD switch is off, the range is –12 – –60 dBu.

4. Hi-Z switch

This switch changes the impedance level of the TRS phone jack to high impedance. It is on when the switch is pushed in. Turn this switch on when connecting a high output impedance device such as guitar or bass.

5. PAD switch

This switch lowers the level of the input signal by 26 dB. The pad is on when the switch is pushed in. When a line level input source is connected, turning the pad on will allow the gain trim knob to have a wider useful range of adjustment.

6. Compressor mode switch

This switch changes the compressor's response speed. Use the Fast setting for short sounds such as drums or percussion, and the Slow setting (press the switch in) for more sustained sounds, such as vocals.

7. Low cut switch

This switch activates a 70 Hz –6 dB/oct low cut filter. Use this to reduce unwanted low-frequency content. The filter is on when the switch is pressed in.

8. Level meter

The meter shows the audio level. If the needle moves into the red area above 0 dB, this indicates that digital clipping is occurring. Set the gain trim knob and the compressor sensitivity knob to prevent the needle from exceeding 0 dB.

9. Gain reduction LED

This LED will light when gain reduction is being applied by the compressor.

10. Compressor sensitivity knob

This specifies the audio level where the compressor begins to kick in. Turning the knob toward the right will increase the sensitivity, so that compression will be applied even at low levels. If you don't want to apply compression, turn this knob all the way to the left.

11. Link switch

Press this switch in to link the two channels together for use with stereo sources. When linked, compression will be applied equally to both channels whenever either channel exceeds the compressor's sensitivity threshold, preserving the stereo imaging.

2. Operation

2-1. Assigning the input

The inputs of the TPB-2 will show up as Input 9 and Input 10 on your D32XD/D16XD. The audio sources connected to the TPB-2's inputs can be assigned to any of the mixer channels. (See D32XD/D16XD owner's manual, p.42 "1. Inputting audio to the mixer")

Preamp input INPUT 9 is shown as the icon, and INPUT10 is shown as the icon.

- Access the MIXER, INPUT/OUTPUT/CH ASSIGN, "Ch Assign" tab page.
- Select "SOURCE" for the channel you want to assign, and use the / buttons to select . You can also use the value dial or the +/- keys to make this selection. In the same way, select for another channel.

2-2. Adjusting the input level

When you've finished making your connections, watch the TPB-2's level meter while you use the gain trim knob to adjust the level. Set the trim knob so that the level meter needle does not exceed 0 dB when the loudest sound is input.

If the level meter goes beyond 0 dB even when the gain trim knob is turned all the way toward the left, press the PAD switch and then use the gain trim knob to adjust the level.

note Normally if the needle goes beyond 0 dB, digital clipping has occurred, causing distortion. You should set the level so that it does not exceed 0 dB.

2-3. Using the compressor

Turn the compressor sensitivity knob all the way to the left so that the compressor is not being applied.

Use the gain trim knob to raise the level so that the meter slightly exceeds 0 dB during the loudest input passages.

Slowly turn the compressor sensitivity knob toward the right. The gain reduction LED will begin to light, indicating that the compressor is being applied.

While watching the level meter, continue turning the compressor sensitivity knob until the level does not exceed 0 dB during the loudest input passages.

If you want to apply a lot of compression to intentionally "squash" a vocal, use the gain trim knob to raise the input level further, and turn the compressor sensitivity knob toward the right to increase the compression.

note By using the gain trim knob to raise the preamp level appropriately, you can saturate the vacuum tube, generating analog overtones to enrich the sound in conjunction with the compressor.

2-4. Using the link switch

Turn on the link switch if you want to use stereo compression. When you're recording a stereo source, and the level of one channel rises to the point where compression is being applied to only that one channel, then the relative volume of the other channel will increase, producing the impression that the stereo image has shifted to one side. In such cases, turning on the link switch will automatically apply compression to both channels at the same time, whenever either channel reaches the compressor's threshold level. So that the compressors for both channels will function in the same way, select the same compressor mode setting for both channels (either Fast or Slow). You should also set the compressor sensitivity knob to about the same setting for both channels.

3. A note about the vacuum tubes

This device contains vacuum tubes. We recommend that you allow the tubes to warm up for about ten minutes after you turn on the power, before you begin running any audio signals through the TPB-2. If you begin using this device immediately after turning on the power, this may cause malfunctions and/or shorten the life of the vacuum tubes.

In order to maximize reliability, avoid placing this device above or below heat-producing equipment such as a power amp.

⚠ Do not attempt to remove, replace or change the tubes in the TPB-2. The tubes are not a user serviceable part.

⚠ Vacuum tubes generate heat. Do not allow your skin to contact the vacuum tube cover for an extended period of time. Doing so can cause low-temperature burns.

4. Specifications

Input connectors: XLR-3-31 type (+48 V phantom power, switchable), 1/4" TRS phone jack (balanced / unbalanced is Hi-Z)

Input impedance: 4 k (XLR-3-31), 10 k (TRS phone Jacks), 1 M (TRS phone Jacks is Hi-Z)

Nominal level: -60 dBu to -12 dBu @ TRIM=max. — min PAD OFF
-34 dBu to +14 dBu @ TRIM=max. — min PAD ON

Maximum level: -48 dBu to 0 dBu @ TRIM=max. — min PAD OFF
-22 dBu to +26 dBu @ TRIM=max. — min PAD ON

Hi-Z
-48 dBu to 0 dBu @ TRIM=max. — min PAD OFF
-22 dBu to +12 dBu @ TRIM=max. — min PAD ON

Source impedance: 600

Vacuum tubes used: 12AX7

Compression method: Vacuum tube compression using a photocoupler

Principal specifications

Frequency response:

10 Hz - 20 kHz ±1 dB @ fs 44.1 kHz, +4 dBu, 10 k load
10 Hz - 22 kHz ±1 dB @ fs 48 kHz, +4 dBu, 10 k load
10 Hz - 44 kHz ±1 dB @ fs 96 kHz, +4 dBu, 10 k load

S/N: 93 dB (typical)

TPB-2 [Tube Preamp Option] for D32XD/D16XD

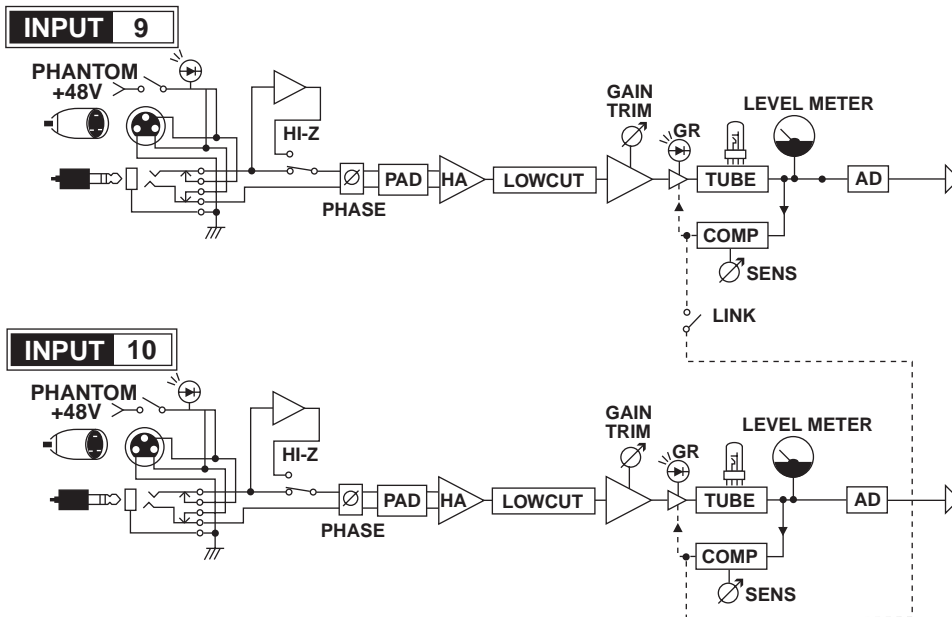

Free Manuals Download Website

<http://myh66.com>

<http://usermanuals.us>

<http://www.somanuals.com>

<http://www.4manuals.cc>

<http://www.manual-lib.com>

<http://www.404manual.com>

<http://www.luxmanual.com>

<http://aubethermostatmanual.com>

Golf course search by state

<http://golfingnear.com>

Email search by domain

<http://emailbydomain.com>

Auto manuals search

<http://auto.somanuals.com>

TV manuals search

<http://tv.somanuals.com>