

TRITON STUDIO

MUSIC WORKSTATION/SAMPLER

Basic Guide

Please read this guide first



HI HYPER INTEGRATED
SYNTHESIS SYSTEM

TouchView
Graphical User Interface

GENERAL MIAI  **CD-RW
installable**

KORG

Ⓔ

①

IMPORTANT SAFETY INSTRUCTIONS

- 1) Read these instructions.
- 2) Keep these instructions.
- 3) Heed all warnings.
- 4) Follow all instructions.
- 5) Do not use this apparatus near water.
- 6) No objects filled with liquids, such as vases, shall be placed on the apparatus.
- 7) Clean only with dry cloth.
- 8) Do not block any ventilation openings, install in accordance with the manufacturer's instructions.
- 9) Do not install near any heat sources such as radiators, heat registers, stoves, or other apparatus (including amplifiers) that produce heat.
- 10) Do not defeat the safety purpose of the polarized or grounding-type plug. A polarized plug has two blades with one wider than the other. A grounding type plug has two blades and a third grounding prong. The wide blade or the third prong are provided for your safety. If the provided plug does not fit into your outlet, consult an electrician for replacement of the obsolete outlet. (for U.S.A. and Canada)
- 11) Protect the power cord from being walked on or pinched particularly at plugs, convenience receptacles, and the point where they exit from the apparatus.
- 12) Only use attachments/accessories specified by the manufacturer.
- 13) Unplug this apparatus during lightning storms or when unused for long periods of time.
- 14) Refer all servicing to qualified service personnel. Servicing is required when the apparatus has been damaged in any way, such as power-supply cord or plug is damaged, liquid has been spilled or objects have fallen into the apparatus, the apparatus has been exposed to rain or moisture, does not operate normally, or has been dropped.
- 15) Do not install this equipment on the far position from wall outlet and/or convenience receptacle.
- 16) Do not install this equipment in a confined space such as a box for the conveyance or similar unit.
- 17) Use only with the cart, stand, tripod, bracket, or table specified by the manufacturer, or sold with this apparatus. When a cart is used, use caution when moving the cart/apparatus combination to avoid injury from tip-over.



WARNING:

TO REDUCE THE RISK OF FIRE OR ELECTRIC SHOCK DO NOT EXPOSE THIS PRODUCT TO RAIN OR MOISTURE.



The lightning flash with arrowhead symbol within an equilateral triangle, is intended to alert the user to the presence of uninsulated "dangerous voltage" within the product's enclosure that may be of sufficient magnitude to constitute a risk of electric shock to persons.



The exclamation point within an equilateral triangle is intended to alert the user to the presence of important operating and maintenance (servicing) instructions in the literature accompanying the product.

CAUTION

Danger of explosion if battery is incorrectly replaced.
Replace only with the same or equivalent type.

THE FCC REGULATION WARNING (for U.S.A.)

This equipment has been tested and found to comply with the limits for a Class B digital device, pursuant to Part 15 of the FCC Rules. These limits are designed to provide reasonable protection against harmful interference in a residential installation. This equipment generates, uses, and can radiate radio frequency energy and, if not installed and used in accordance with the instructions, may cause harmful interference to radio communications. However, there is no guarantee that interference will not occur in a particular installation. If this equipment does cause harmful interference to radio or television reception, which can be determined by turning the equipment off and on, the user is encouraged to try to correct the interference by one or more of the following measures:

- Reorient or relocate the receiving antenna.
- Increase the separation between the equipment and receiver.
- Connect the equipment into an outlet on a circuit different from that to which the receiver is connected.
- Consult the dealer or an experienced radio/TV technician for help.

Unauthorized changes or modification to this system can void the user's authority to operate this equipment.

CE mark for European Harmonized Standards

CE mark which is attached to our company's products of AC mains operated apparatus until December 31, 1996 means it conforms to EMC Directive (89/336/EEC) and CE mark Directive (93/68/EEC). And, CE mark which is attached after January 1, 1997 means it conforms to EMC Directive (89/336/EEC), CE mark Directive (93/68/EEC) and Low Voltage Directive (73/23/EEC).

Also, CE mark which is attached to our company's products of Battery operated apparatus means it conforms to EMC Directive (89/336/EEC) and CE mark Directive (93/68/EEC).

Data handling

Incorrect operation or malfunction may cause the contents of memory to be lost, so we recommend that you save important data on a floppy disk or other media. Please be aware that Korg will accept no responsibility for any damages which may result from loss of data. Also, when digitally recording copyrighted audio material from a DAT or CD etc., you must obtain permission for use. Please be aware that Korg will accept no responsibility for any copyright violations which may occur through your use of this product.

Handling of the internal hard drive

Do not apply physical shock to this device. In particular, you must never move this device or apply physical shock while the power is turned on. This can cause part or all of the data on disk to be lost, or may damage the hard disk or interior components.

When this device is moved to a location where the temperature is radically different, water droplets may condense on the disk drive. If the device is used in this condition, it may malfunction, so please allow several hours to pass before operating the device.

Do not repeatedly turn the power on/off. This may damage not only the TRITON STUDIO, but also any SCSI devices that are connected.

This device begins to access the hard drive immediately after the power is turned on.

Never turn off the power while the hard drive is being accessed. Doing so can cause all or part of the data on the disk to be lost, or may cause malfunctions such as damage to the hard drive.

If the hard drive has been damaged due to incorrect operation, power failure, or accidental interruption of the power supply, a fee may be charged for replacement even if this device is still within its warranty period.

COPYRIGHT WARNING

This professional device is intended only for use with works for which you yourself own the copyright, for which you have received permission from the copyright holder to publicly perform, record, broadcast, sell, and duplicate, or in connection with activities which constitute "fair use" under copyright law. If you are not the copyright holder, have not received permission from the copyright holder, or have not engaged in fair use of the works, you may be violating copyright law, and may be liable for damages and penalties. If you are unsure about your rights to a work, please consult a copyright attorney. **KORG TAKES NO RESPONSIBILITY FOR ANY INFRINGEMENT COMMITTED THROUGH USE OF KORG PRODUCTS.**

* Company names, product names, and names of formats etc. are the trademarks or registered trademarks of their respective owners.

Thank you for purchasing the **Korg TRITON STUDIO music workstation/sampler**. To ensure trouble-free enjoyment, please read this manual carefully and use the instrument as directed.

About this manual

The owner's manuals and how to use them

The TRITON STUDIO come with the following owner's manuals.

- Basic Guide
- Parameter Guide
- Voice Name List

Basic Guide

First read this manual carefully to gain a basic understanding of the instrument and to learn basic operation.

“**Introduction**” explains the function of each part, how to make connections, basic operation, and gives an overview of each mode.

“**Quick Start**” explains the basics of playing the TRITON STUDIO (how to listen to the demo songs, select sounds, and use convenient performance functions), and describes examples of how to perform sampling and use the sequencer.

If you wish to begin playing immediately, read this section first.

“**Basic Functions**” contains mode-by-mode explanations of what you need to know to edit sounds, record using the sequencer, and to record samples. This section also explains how to use the arpeggiator, effects, and MIDI.

“**Appendices**” contains information on troubleshooting, specifications, and various other information.

Parameter Guide

The Parameter Guide contains explanations and other information regarding the operations of the parameters and settings on the TRITON STUDIO. The explanations are organized by mode, and page.

Explanations and other information on the effects and their parameters are also provided for each effect.

Refer to this guide when an unfamiliar parameter appears in the display, or when you need to know more about a particular function.

Voice Name List

This lists the multisamples and drumsamples that are built into the TRITON STUDIO, and the factory preset combinations, programs, drum kits, and user arpeggio patterns.

Refer to these lists when you wish to know more about the preloaded sounds.

Conventions in this manual

References to the TRITON STUDIO

The TRITON STUDIO is available in 88-key, 76-key and 61-key models, but all three models are referred to without distinction in this manual as “the TRITON STUDIO.” Illustrations of the front and rear panels in this manual show the 61-key model, but the illustrations apply equally to the 88-key and 76-key models.

Abbreviations for the manuals BG, PG, VNL

References to the manuals included with the TRITON STUDIO are abbreviated as follows in this document.

BG: Basic Guide

PG: Parameter Guide

VNL: Voice Name List

Keys and knobs []

References to the keys, dials, and knobs on the TRITON STUDIO's panel are enclosed in square brackets []. References to **buttons** or **tabs** indicate objects in the LCD display screen.

Parameters in the LCD display screen “ ”

Parameters displayed in the LCD screen are enclosed in double quotation marks “ ”.

Boldface type

Parameter values are printed in boldface type. Content that is of particular importance is also printed in boldface type.

Procedure steps ① ② ③ ...

Steps in a procedure are listed as ① ② ③ ...

p. ■

These indicate pages or parameter numbers to which you can refer.

Symbols , ,

These symbols respectively indicate cautions, advice, and MIDI-related explanations.

Example screen displays

The values of the parameters shown in the example screens of this manual are only for explanatory purposes, and may not necessary match the values that appear in the LCD screen of your instrument.

MIDI-related explanations

CC# is an abbreviation for Control Change Number. In explanations of MIDI messages, **numbers in square brackets []** always indicate hexadecimal numbers.

Table of Contents

Data handling.....	iii	Using controllers to modify the sound	25
Handling of the internal hard drive	iii	Joystick.....	25
COPYRIGHT WARNING	iii	Ribbon controller.....	25
About this manual.....	iv	SW1, SW2	25
Introduction.....	1	REALTIME CONTROLS [1], [2], [3], [4].....	26
Main features.....	1	[VALUE] slider	27
Front and rear panel	3	Keyboard	27
Front panel.....	3	Foot pedals/Switch.....	28
Rear panel.....	6	ARPEGGIATOR [TEMPO] knob, [GATE] knob, [VELOCITY] knob.....	28
Names and functions of objects in the LCD screen ..	8	Using the arpeggiator while you play	29
Connections	10	Using the arpeggiator in Program mode.....	29
1. Connecting the power cable.....	11	Settings using controllers.....	29
2. Analog audio output connections.....	11	Settings in the LCD screen.....	30
3. Analog audio input connections	11	Using the arpeggiator in Combination mode	31
4. Digital audio input/output connections.....	11	Settings in the LCD screen.....	31
5. Connecting pedals.....	11	Playing with the RPPR (Realtime Pattern Play/ Recording) function	33
6. SCSI device connections.....	12	Simple program editing	34
7. Connections to MIDI equipment/computers ..	12	Performance Edit.....	34
8. Installing options.....	12	Realtime controls.....	34
Basic concepts	13	Simple combination editing	35
Overview of the modes.....	13	An example of editing	35
About polyphony	15	Sampling (recording a sample)	37
Tone generators and oscillators.....	15	Sampling a vocal from a mic, and playing it as a “one-shot” sample.....	37
Number of voices in each mode.....	15	Applying an insert effect to the audio input and sampling the result	39
Basic operation.....	16	Assigning a name to the sample or multisample ..	40
1. Selecting modes	16	Saving sample data	41
2. Selecting pages.....	16	Converting a multisample into a program.....	41
3. Setting a parameter	17	Sampling and looping a drum phrase	42
Quick Start.....	19	Resampling an arpeggiated phrase in Program mode.....	45
Turning the power on/off	19	Sample an arpeggiated drum phrase together with an externally-input guitar	46
1. Turning the power on.....	19	Producing a song	49
2. Turning the power off.....	19	Creating the basic song	49
Listening to a demo song	20	Naming the song and tracks.....	53
1. Loading the demo song data in Disk mode.....	20	Saving the song.....	54
2. Selecting and playing a demonstration song in Sequencer mode.....	21		
Playing a cue list.....	21		
Selecting and playing a program	22		
Selecting a program.....	22		
Selecting and playing a combination	24		
Selecting a combination.....	24		

Basic functions 55

Saving data	55
Types of data that can be saved	55
Writing to internal memory	56
Writing a program or combination.....	56
Writing global settings, user drum kits, and user arpeggio patterns	58
Saving on media	59
Types of media that can be used.....	59
Formatting media.....	60
How to save data.....	60
MIDI data dump.....	62

Loading data and restoring the factory settings	63
Loading data	63
Types of data that can be loaded	63
Loading data/Restoring the factory settings.....	63
Loading .PCG files and .SNG files from the floppy disks included with the EXB-PCM series and EXB-MOSS options	65

Program settings	67
How a program is organized.....	67
Basic program editing.....	67
Oscillator settings P1: Edit-Basic.....	68
Pitch settings P2: Edit-Pitch.....	70
Filter settings P3: Edit-Filter	71
Amplifier settings P4: Edit-Amp.....	72
LFO settings P5: Edit-Common LFO	74
Arpeggiator settings P7: Edit-Arpeggiator.....	74
Insert Effect settings P8: Edit-Insert Effect	74
Master Effect settings P9: Edit-Master Effect	74
More about Alternate Modulation.....	74

Combination settings	75
How a combination is organized	75
Basic combination editing	75
Timbre 1-8 program, pan and volume	
P1: Edit-Program/Mixer	76
Settings for status, MIDI channel, and pitch parameters P2: Edit-Trk Param	77
MIDI filter settings P3: Edit-MIDI Filter	78
Layer, split, and velocity switch settings/Controller settings P4: Edit-Zone/Ctrl	78
Arpeggiator settings P7: Edit-Arp.	79
Insert Effect settings P8: Edit-Insert FX.....	79
Master Effect settings P9: Edit-Master FX	79

Producing songs	80
Features of the sequencer	80
The structure of Sequencer mode	81
Songs	81
Patterns	81
Cue List	81
Preparations for recording	82
Recording methods	83
Realtime recording on a track	83
Step recording.....	86
Event Edit and Create Control Data.....	86
Realtime-recording to a pattern	86

Song editing methods.....	88
1. Copying a song.....	88
2. Naming a song	88
3. Setting the number of measures in the song.....	88
4. Changing the key (transposing/modulating).....	89
Creating and playing a Cue List	90
Converting a song.....	92
Creating and recording RPPR (Realtime Pattern Play/Record)	92
Creating RPPR data	92
RPPR playback	93
Realtime-recording an RPPR performance	94
Recording the sounds of a combination	95
Caution and other functions in Sequencer mode.....	97

Sampling settings	99
Features of sampling on the TRITON STUDIO.....	99
How Sampling mode is organized.....	100
Samples and Multisamples.....	101
Preparations for sampling	102
1. Connecting an input device and making <i>Input</i> settings.....	102
2. Setting the recording level (Recording Level [dB])	103
3. Specifying the recording method (Recording Setup/Sampling Setup)	104
4. Making settings for the sample to be recorded (REC Sample Setup/Sampling Setup)	104
Sampling and editing in Sampling mode.....	106
Creating multisample indexes and sampling ..	106
Applying an insert effect to a sample and resampling it.....	107
Ripping	108
Loop settings.....	110
Sample (waveform data) editing	111
Multisample editing	111
Converting a multisample to a program	112
Using Time Slice to divide a sample, and playing it in Sequencer mode	112
Sampling in Program, Combination, or Sequencer modes.....	115
Record an external audio input source while a song plays, and create event data at the same time (In-Track Sampling function).....	115
Resampling the song playback to create a WAVE file on the hard drive	116

Creating an audio CD from WAVE files sampled to hard disk	118
SMF (Standard MIDI File) playback	120
The structure of Song Play mode	120
Playing SMF data.....	121
Playback using the Jukebox function	122
Saving a Jukebox list	122
Playing along with SMF data.....	123
Settings for the entire TRITON STUDIO (Global settings).....	124
Tuning to another instrument/Transposing.....	124
Adjusting the way in which velocity or after touch will affect the volume or tone.....	124
Bypassing the effects.....	124
Recalling the last-selected mode and page at power-on	125
Specifying the function of the ASSIGNABLE Switch and ASSIGNABLE Pedal.....	125
Creating original scales.....	126
Drum kit settings	127
About drum kits	127
Editing a drum kit	128
Arpeggiator settings	130
Arpeggiator settings for a program	130
Arpeggiator on/off	130
Arpeggiator settings.....	130
Arpeggiator settings in Combination and Sequencer modes	132
Arpeggiator on/off	132
Arpeggiator settings.....	132
Creating an user arpeggio pattern	134
About user arpeggio patterns.....	134
Editing a user arpeggio pattern.....	134
Dual arpeggiator editing	137
Synchronizing the arpeggiator	138
Synchronization between arpeggiators A and B.....	138
Synchronization between the arpeggiators and sequencer in Sequencer or Song Play mode	138
Synchronization with an external sequencer in Program, Combination, or Sequencer modes .	138
Effects settings.....	139
Effects in each mode.....	139
Routing settings and effect settings	140
Effect settings for a program.....	140
Effect settings in Combination, Song, and Song Play modes	141
Effect settings in Sampling mode.....	142
Effect settings for AUDIO INPUT.....	143
About dynamic modulation (Dmod).....	144

Other functions	145
Setting the function of [SW1] and [SW2]	145
Setting the B-mode functions of REALTIME CONTROLS [1]-[4]	145
Adjusting the contrast (brightness) of the LCD screen	145
Sounding a beep when the LCD screen is pressed.....	146
Using the TRITON STUDIO as a data filer	146
Setting the calendar function.....	146
Shortcuts.....	146

Appendices 147

Troubleshooting	147
Power supply.....	147
LCD screen.....	147
Audio input and output.....	147
Program, Combination.....	149
Song.....	149
Sampling.....	149
Drum kits.....	150
Arpeggiator	150
Effects.....	150
MIDI	151
Media	151
WAVE files.....	152
Other	152
Specifications and options.....	153
Specifications	153
Options	154
MIDI implementation chart	155
Index	156



Introduction

Main features

Overview

The TRITON STUDIO is a music workstation/sampler that features the **HI (Hyper Integrated) synthesis system** as its tone generator.

It provides high-quality preset multisamples/programs/combinations and an effect section, and functions such as sampling, sequencer, song play, dual polyphonic arpeggiator, RPPR, six audio outputs and can support up to six audio inputs.

A rich array of controllers such as the joystick, ribbon controller, assignable switches [SW1] & [SW2], assignable/preset knobs REALTIME CONTROLS [1]–[4], ARPEGGIATOR [TEMPO], [GATE], [VELOCITY] knobs, and a variety of optional pedals can be used to modify the sound while you play.

You can further expand the potential of the TRITON STUDIO by installing options such as a MOSS tone generator, PCM expansion boards, additional sampling memory, ADAT digital output, mLAN interface board, and a CD-R/RW drive. (PG p.286)

The TRITON STUDIO music workstation is a powerful tool for music production or live performance.

HI (Hyper Integrated) synthesis system

The HI (Hyper Integrated) synthesis system is a PCM tone generator system with full digital signal processing that guarantees pristine sound, and featuring enormous flexibility in musical expression, modulation, and effect routing.

Tone generator section:

- 48 Mbytes of preset PCM ROM contains 429 multisamples and 417 drumsamples. By installing optional EXB-PCM series PCM expansion boards (16 Mbytes PCM ROM), you can expand the PCM data to a maximum of 112 Mbytes.
- 16 Mbytes of RAM is standard (expandable to a maximum of 96 Mbytes). Samples or multisamples that you sampled or resampled in Sampling mode or other modes (or that you loaded in Disk mode) can be used as sound sources.
- The sampling frequency is 48 kHz, and the maximum polyphony is 60 voices (a maximum of 120 voices can be used depending on the PCM sounds you use).
p.15

Filter/synthesis section:

- Either a 24 dB/oct Resonant Low Pass or a 12 dB/oct Low Pass & High Pass type filter can be used. A wide variety of filter effects can be achieved, from active sounds with aggressive resonance to subtle tones using a high pass filter.
- A broad range of editing parameters gives you precise control over every aspect of the sound.

Effect section:

- Five insert effects (stereo-in/stereo-out), two master effects (mono-in/stereo-out), and a three-band master EQ (stereo-in/stereo-out) can all be used simultaneously. You can select and edit any of 102 types of effect algorithms.
- The effect routing is highly flexible. Effects can be routed freely to the individual inputs and outputs.

Alternate Modulation and Effect Dynamic Modulation:

- The synthesis section (filter etc.) provides Alternate Modulation capabilities, and the effect section provides Effect Dynamic Modulation. This allows you to freely apply modulation to parameters that affect the pitch, filter, amp, EG, LFO, and effects etc.
- LFO, delay time and other effect parameters can be synchronized to an external MIDI clock. You can also synchronize sounds and effects to the tempo of the internal sequencer or the arpeggiator.

Programs and combinations

- In preset ROM, the TRITON STUDIO provides 1,536 user programs, and 256 programs + 9 drumsets for GM2 compatibility. When shipped from the factory, it contains high-quality preload programs (512) that cover a wide range of musical needs. The 1,536 user programs can be modified by adjusting the numerous editing parameters, the effects and the arpeggiator, to create your own original programs. When the EXB-MOSS option is installed, 128 programs for use with the Korg MOSS tone generator will also be available.
- The TRITON STUDIO provides 144 user drum kits as well as 9 ROM drum kits compatible with GM2. The factory settings contain 20 preloaded drum kits that cover a wide range of musical styles. You can create your own drum kits by assigning each key to any one of the 417 drum samples or to an original sample that you sampled or loaded in from media. For the sound assigned to each key, you can make filter and amp settings, and even route the sound to effects or individual audio outputs.
- A multisample or sample that was sampled or resampled in Sampling mode or other modes (or loaded in from media using the Disk mode) can be easily used to create a program. These programs can also be used in a combination or song. Samples can also be used as drum instruments in a drum kit.
- The TRITON STUDIO provides 1,536 user combinations. With the factory settings, these contain a wide variety of preload combinations (512). A combination allows you to use layers, splits, or velocity switches to combine up to eight programs together with effects and two arpeggiators, in order to create complex sounds that could not be produced by a single program. You can also make settings that include external tone generators.

Sampling

The TRITON STUDIO features an Open Sampling System that allows sampling and resampling to be performed not only in Sampling mode, but also in Program, Combination, or Sequencer modes.

You can perform 48 kHz 16-bit linear mono or stereo sampling; 16 Mbytes of sample memory (RAM) as well as a hard drive are factory-installed. (For the capacity of the hard drive, refer to p.154.)

Sample memory (RAM) of 16 Mbytes is factory-installed, allowing approximately 2 minutes 54 seconds of mono sampling (or approximately 1 minute 27 seconds of stereo sampling). Sample memory can be expanded to a maximum of 96 Mbytes, which allows you to record up to six samples of approximately 2 minutes 54 seconds each (mono) or approximately 1 minute 27 seconds each (stereo), for a total 17 minutes 28 seconds of sampling time. The **hard drive** lets you record up to 80 minutes as a single sample file in either mono or stereo (monaural: approximately 440 Mbytes, stereo: approximately 879 Mbytes). This will create a WAVE file. (In order to play a hard disk sample from the TRITON STUDIO's keyboard, it must be able to be loaded into the sampling memory (RAM). Sample files of up to 16 Mbytes (mono) or 32 Mbytes (stereo) can be loaded into RAM.)

For more on the sampling features of the TRITON STUDIO (Ⓢp.99).

Sequencer

A sophisticated 16-track MIDI sequencer is built in. The sequencer can be used in conjunction with other functions such as the dual arpeggiator and RPPR, making it an even more powerful music production tool than a stand-alone sequencer.

In addition, you can sample while listening to sequencer tracks play back – just as if you were recording an audio track (In-Track Sampling).

For more on the TRITON STUDIO's sequencer (Ⓢp.80).

Song Play

In Song Play mode, SMF (Standard MIDI File) songs can be played back directly from floppy disk or other media. You can also play the keyboard along with the SMF playback. You can play along on the keyboard as you listen to the SMF playback, and even play the arpeggiator in sync with the playback tempo of the SMF.

- Formats 0 and 1 are supported.
- A jukebox function lets you edit the order in which songs are played back.

Dual polyphonic arpeggiator

- Five preset arpeggio patterns (UP, DOWN, ALT1 ALT2, RANDOM) and 507 user arpeggio patterns are provided. With the factory settings, these contain a wide variety of preload user patterns (367).

In addition to providing conventional arpeggiator functions, the polyphonic arpeggiator of the TRITON STUDIO can respond to the pitches or timing at which you play the keyboard, and produce a diverse range of chords or phrases. This can be used to play a variety of drum phrases (using the "Fixed Note Mode" that is ideal for drums), bass phrases, or guitar and keyboard backing riffs. The arpeggiator is also effective for use with subtly moving pads, synth sounds, or sound effects.

In Combination mode, Sequencer mode, and Song Play mode, the TRITON STUDIO provides dual arpeggiators that can simultaneously play two arpeggio patterns. You can apply separate arpeggio patterns to drum and bass programs, or use keyboard splits or velocity to switch between arpeggio patterns for an even more dynamic performance.

RPPR

The TRITON STUDIO features Korg's RPPR (Realtime Pattern Play/Recording) function.

In Sequencer mode, this function allows you to assign preset patterns or user patterns (with a specified playback track) to individual notes of the keyboard, and playback that pattern in realtime simply by pressing the assigned note. Numerous preset patterns, including patterns ideal for drum tracks, are built into the internal memory.

6-channel audio input/6-channel audio output

- Both analog (2 channel) and digital (2 channel) audio inputs are standard, allowing you to record stereo samples. (If the EXB-mLAN option is installed, two more input channels will be added.)

The analog inputs have a MIC/LINE level select switch and a level knob, accommodating a wide range of audio sources from mic level to line level.

The digital inputs support S/P DIF format.

Audio inputs can also be routed to the effects. You can apply effects while sampling, and use the TRITON STUDIO as a 6-in/6-out effect processor or even create a vocoder effect in conjunction with internal sounds.

- 6 channels of audio output are standard: four individual audio outputs in addition to the L/MONO and R main stereo audio outputs. Oscillators, drums, timbres/tracks, and the insert effect outputs can all be freely routed to any output.

As analog outputs, the TRITON STUDIO provides AUDIO OUTPUT (MAIN) L/MONO, R, and (INDIVIDUAL) 1, 2, 3, and 4.

As digital output, you can use S/P DIF (2 channels: L/MONO and R), ADAT (when the EXB-DI option is installed), and mLAN (6 channels: when the EXB-mLAN option is installed).

- S/P DIF input and output support 48 kHz/96 kHz sampling frequencies. You can interface directly to a 96 kHz sampling frequency digital recording system.

TouchView user interface

The TRITON STUDIO uses a TouchView user interface that lets you operate the instrument directly by touching a large 320 × 240 pixel LCD screen, for a revolutionary leap in ease of operation and user friendliness. When selecting programs, combinations, multisamples, drumsamples, or effects in the LCD screen, you can also view and select by categories such as types of instrument.

CD-RW drive

When the CDRW-1 (CD-R/RW drive) option is installed, you can create original CD's, back up your data, or play back and sample from audio CD's without the need to connect any external equipment.

Front and rear panel

Front panel

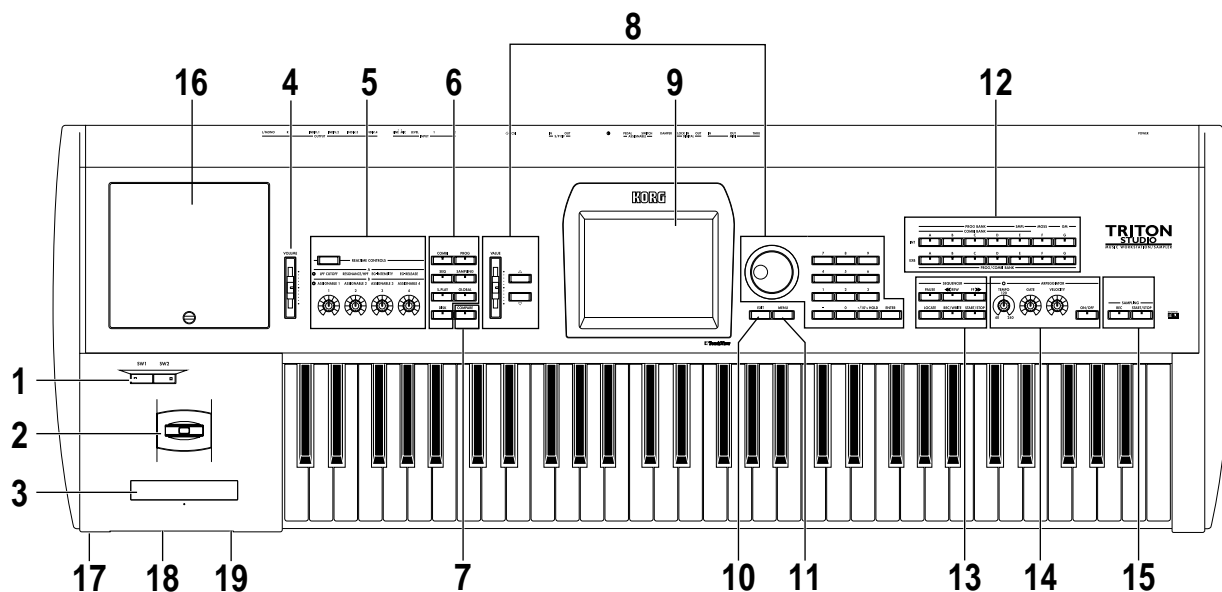

1. [SW1] key, [SW2] key

These keys are on/off switches, their function can be assigned in Program, Combination, Sequencer, Song Play, and Sampling modes. When on, the LED will light (see p.25).

2. Joystick

This controls pitch and modulation.

Move the joystick up/down and left/right (+Y, -Y, -X, +X) to vary the effect (see p.25).

Various program parameters and effect parameters will determine what is being controlled by the joystick.

3. Ribbon controller

Slide your finger to the left or right on this ribbon controller to control the pitch or modulation (see p.26).

Various program parameters and effect parameters will determine what is controlled by the ribbon controller.

4. [VOLUME] slider

This adjusts the volume that is output from the AUDIO OUTPUT (MAIN) L/MONO, R jacks and the headphone jack.

5. REALTIME CONTROLS

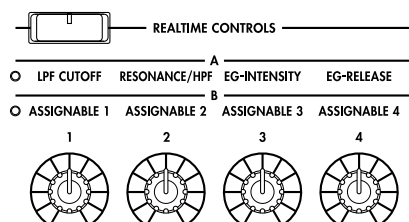

Use the [REALTIME CONTROLS] key to select A or B mode for the realtime controllers, and use knobs [1]-[4] to control the tone, effects, and MIDI control changes etc. in realtime (see p.26).

[REALTIME CONTROLS] key

This key selects either A or B mode for the realtime controllers. The selected mode will light.

[1] knob, [2] knob, [3] knob, [4] knob

In A mode, the function of each knob is fixed. [1] is the low pass filter cutoff frequency, [2] is the filter resonance level or the cutoff frequency of the high pass filter, [3] is the filter EG intensity, and [4] is the filter/amp release time.

In B mode, each knob will control the function that was assigned to it in the Program, Combination, Sequencer, Song Play, or Sampling modes.

6. Mode keys

Use these keys to enter the desired mode.

When you press a key, the LED will light, and you will enter the mode whose key you pressed (see p.16).

[COMBI] key

Combination mode will be selected.



[PROG] key

Program mode will be selected.

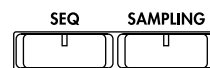

[SEQ] key

Sequencer mode will be selected.

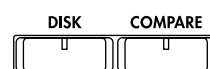
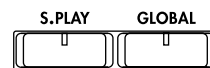

[SAMPLING] key

Sampling mode will be selected.

[S.PLAY] key

Song Play mode will be selected.

[GLOBAL] key

Global mode will be selected.

[DISK] key

Disk mode will be selected.

7. [COMPARE] key

Use this key when you wish to compare the sound of the program or combination that you are currently editing with the un-edited sound already in memory. You can also use this key to make "before and after" comparisons when recording or editing in Sequencer mode (p.17).

8. VALUE controllers

The following VALUE controllers are used to set the value of the selected parameter (p.17).

[VALUE] slider

Use this to modify the value of a parameter. This controller is convenient when you wish to make large changes in the value.

This slider can also be used as a modulation source.

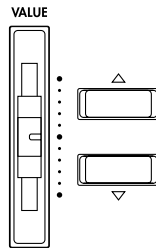

[△][▽] keys

These are used to increase or decrease the parameter value in steps of one. It is convenient to use these to make fine adjustments.

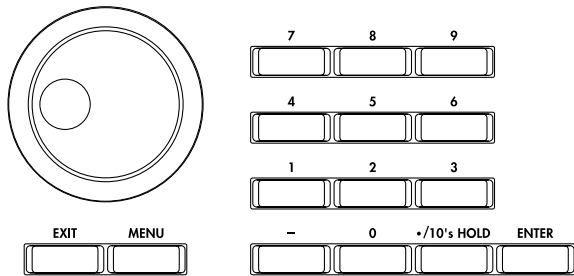

[VALUE] dial

Use this dial to modify the value of the parameter.

Numeric keys [0] – [9], [ENTER] key, [-] key [./10's HOLD] key

Use these keys to numerically input a parameter value. Use numeric keys [0]–[9], the [-] key, and the [./10's HOLD] key to enter the value, and press the [ENTER] key to confirm it. The [./10's HOLD] key lets you input a value with a decimal point. The [-] key inverts the sign (+/-) of the parameter value.

The [./10's HOLD] key is also used when you wish to hold the 10's place while selecting programs or combinations.

By holding down the [ENTER] key and pressing a numeric key [0]–[9], you can select up to ten page menu commands in the current page.

9. LCD screen

The TRITON STUDIO features a Touch-View system that uses a touch-panel LCD screen.

By touching on objects that are shown in the LCD screen, you can select pages, tabs, and parameters, and set values (p.8).

10. [EXIT] key

When a dialog box is open, this key will cancel the settings made in the dialog box and close the dialog box (corresponds to the Cancel button). If a popup menu or page menu is open, pressing [EXIT] will close the menu.

When in P (page) 1–9 of each mode, pressing the [EXIT] key will move to P (page) 0 of that mode.

11. [MENU] key

Use this key to move between pages. When you press the [MENU] key, a list of the pages in the mode will appear in the LCD screen. Press the desired page, and you will move to that page. You can also move to a page by holding down the [MENU] key and pressing the corresponding numeric key [0]–[9] (p.16).

12. BANK keys

These keys are used to switch the program/combination bank.

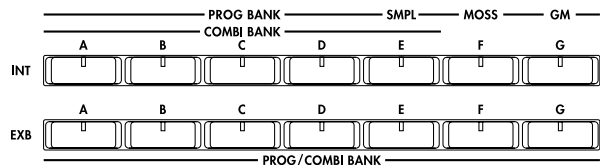

PROG BANK:

[INT-A], [INT-B], [INT-C], [INT-D], [INT-E] (SMPL), [INT-F] (MOSS), [INT-G] (GM), [EXB-A], [EXB-B], [EXB-C], [EXB-D], [EXB-E], [EXB-F], [EXB-G]

COMBI BANK:

[INT-A], [INT-B], [INT-C], [INT-D], [INT-E], [EXB-A], [EXB-B], [EXB-C], [EXB-D], [EXB-E], [EXB-F], [EXB-G]

In Program mode, these keys select the program bank.

In Combination mode, these keys select the combination bank. When assigning a program to the various timbres in a combination, then these keys will select the program bank. In this case, the LED of the program bank selected for the timbre will light.

In Sequencer and Song Play modes when the edit cell (highlighted area) is located at the program of each track, these keys select the program bank just as in Combination mode.

If you repeatedly press the [INT-G] key when selecting a program, the bank selection will cycle through all of the GM(2) banks and drum banks in the order of G, g(1), g(2)–g(8), g(9), g(d), G ... each time you press the key.

The [INT-F] bank can be selected in Program mode only if the EXB-MOSS option is installed.

13. SEQUENCER

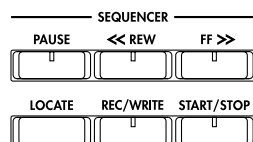

[PAUSE] key

In Sequencer mode, this key pauses the playback of the song or cue list. In Song Play mode, this key pauses SMF playback. When paused, the LED will light. Press [PAUSE] once again to resume playback; the LED will turn off.

[<<REW] key

In Sequencer mode, this key will rewind the song or cue list. When you press and hold this key, the LED will light, and the playback will rewind. (This key will not function during recording.)

[FF>>] key

In Sequencer mode, this key will fast-forward the song or cue list. When you press and hold this key, the LED will light, and the playback will fast-forward. (This key will not function during recording.)

[LOCATE] key

In Sequencer mode, this key will advance or rewind the song or cue list playback to a specified point. In Song Play mode, this key returns the playback location of the SMF to a specified point.

SEQUENCER [REC/WRITE] key

In Sequencer mode, pressing this key will make the LED light, and if you then press the SEQUENCER [START/STOP] key, recording will begin (p.84).

In Program, Combination and Global modes, pressing this key will open a dialog box, and if you then press the OK button, the edited contents will be written (p.57, 59).

SEQUENCER [START/STOP] key

This is the start/stop key for song or cue list recording and playback in Sequencer mode, and SMF playback in Song Play mode. (During recording and playback, the LED will blink at the current tempo.)

These keys are also used to play an audio CD in the CDRW-1 option or in a SCSI-connected CD-R/RW drive.

SEQUENCER [START/STOP] key	: Play/Stop
[FF>>] key	: Fast-forward
[<<REW] key	: Rewind
[PAUSE] key	: Pause
[LOCATE] key	: Return to the beginning of the track

14. ARPEGGIATOR

These knobs control the performance of the arpeggiator in realtime (p.29).

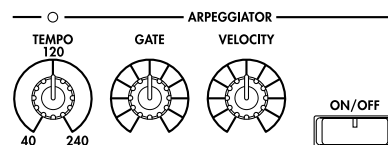

[TEMPO] knob

This adjusts the base tempo of the arpeggiator and sequencer. The LED will blink at quarter-note intervals of the current tempo.

[GATE] knob

This adjusts the gate time (note duration) of the arpeggiated notes. At the center position (12 o'clock), the gate time will be the same as the "Gate" parameter of the arpeggiator. Rotating the knob toward the left will shorten the gate time, and rotating it toward the right will lengthen the gate time.

[VELOCITY] knob

This adjusts the velocity (playing strength) of the arpeggiated notes. At the center position (12 o'clock), the velocity will be the same as the "Velocity" parameter of the arpeggiator. Rotating the knob toward the left will decrease the velocity, and rotating it toward the right will increase the velocity.

[ON/OFF] key

This switches the Arpeggiator function on/off. When on, the LED will light.

15. SAMPLING

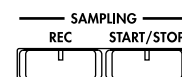

SAMPLING [REC] key

In Sampling, Program, Combination, and Sequencer modes, pressing this key will make the LED light, and when you continue by pressing the SAMPLING [START/STOP] key, sampling will either begin or you will enter the sample-ready mode. (p.37)

SAMPLING [START/STOP] key

In Sampling, Program, Combination, and Sequencer modes, pressing this key after pressing the SAMPLING [REC] key will either cause sampling to begin, or it will access the sample-ready mode.

In the Sampling P1: Sample Edit page, pressing this key will sound the selected sample.

This key is also used to play back a WAVE file from the internal hard disk. This function can be used in the directory window of various Disk mode pages, in the Disk mode Make Audio CD page, and in the "Select Directory" page menu dialog box of the Program, Combination, Sequencer, and Sampling modes.

16. EXB-PCM/sample memory (RAM) slot cover

Open this cover to install EXB-PCM option boards, or to install SIMMs to increase the sampling memory (RAM). Up to seven EXB-PCM option boards can be installed, and up to three SIMM sampling memory (RAM) boards can be installed. (PG p.286)

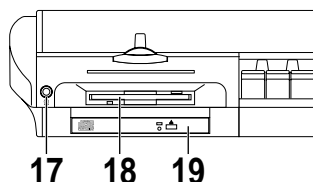

17. Headphone jack

A set of headphones can be connected here (stereo 1/4" jack).

This allows stereo monitoring of the same signal as the OUTPUT L/MONO and R jacks.

18. Floppy disk drive

3.5 inch 2DD (double-side double-density) or 2HD (double-side high-density) floppy disks can be inserted here, allowing you to save your edited data, or to load factory-set data, SMF data, or multisample/sample data, etc...

For details on handling floppy disks, refer to "Cautions when handling floppy disks" (p.62).

Eject button

To remove a floppy disk, make sure that the disk access indicator is dark, and then press this button. If the disk is not ejected when you press this button, do not attempt to forcibly remove the disk, but contact your Korg distributor.

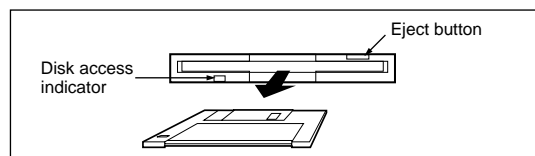

19. CDRW-1 drive bay

The CDRW-1 (CD-R/RW drive) option can be installed in this bay. (PG p.286)

Rear panel

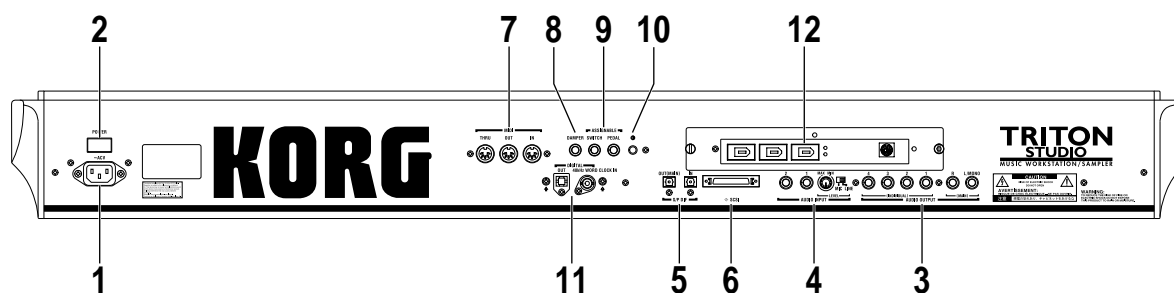

1. AC power supply connector

Connect the included power supply cable here.

After connecting the power supply cable to the TRITON STUDIO, connect the other end to an AC outlet (p.11).

2. [POWER] switch

This switch turns the power on/off (p.19).

3. AUDIO OUTPUT

Connect these outputs to the input jacks of your amp or mixer. In addition to the L/MONO and R main stereo audio outputs, the TRITON STUDIO provides four individual audio outputs. The sound from each oscillator, drum, timbre/track, or insert effect can be freely routed to any output (p.139-).

(MAIN) L/MONO, R

These are unbalanced phone jacks.

These are the main audio output jacks. By setting "Bus Select" to L/R, the output from an oscillator, an insert effect, an individual drum part, or the metronome can be output to the (MAIN) L/MONO and R jacks.

When making connections in stereo, use L/MONO and R. When making connections in mono, use the L/MONO jack.

(INDIVIDUAL) 1, 2, 3, 4

These are unbalanced phone jacks.

These are individual (independent) audio output jacks. By setting the "Bus Select" to 1, 2, 3, 4, 1/2, or 3/4, an oscilla-

tor, an insert effect, an individual drum part, or the metronome etc. can be assigned to be output from the (INDIVIDUAL) 1, 2, 3, 4, jacks.

The output from the 1, 2, 3, 4 jacks is not affected by the [VOLUME] slider.

4. AUDIO INPUT

These two audio inputs are used when recording a mono/stereo sample from a mic or external audio source (p.37), or when applying the TRITON STUDIO's internal effects to an external audio source (p.143).

The MIC/LINE level select switch ([MIC/LINE] switch) and the level adjustment knob ([LEVEL] knob) allow you to use a wide range of external audio sources, ranging from mic level to line level.

AUDIO INPUT 1/2 jacks

These are unbalanced phone jacks.

[LEVEL] knob

This adjusts the input level of the AUDIO INPUT 1/2 jacks.

[MIC/LINE] switch

This switches the input level of the AUDIO INPUT 1/2 jacks.

5. S/P DIF

OUT(MAIN) jack

This is an optical type S/P DIF format (IEC60958, EIAJ CP-1201) digital output jack. It outputs a digital version of the same audio signal as the AUDIO OUTPUT (MAIN) L/MONO and R jacks, at sampling rates of 48 kHz or 96 kHz (PG p.138). Use an optical cable to connect this to the optical digital input jack of a DAT or MD, etc. The [VOLUME] slider does not adjust the output level of this jack.

IN jack

This is an optical S/P DIF format (IEC 60958, EIAJ CP-1201) digital input jack. Digital audio at a sample rate of 48 kHz or 96 kHz can be input here. 96 kHz audio will be converted to 48 kHz. (PG p.138) Use an optical cable to connect this jack to the optical digital output jack of a DAT or other device.

6. SCSI connector

This is a D-sub half-pitch 50 pin SCSI connector. An external hard disk drive can be connected here and used to sample or to save/load data in the same way as the internal hard disk drive. A CD-R/RW can also be connected here to create an audio CD or to save/load data. (p.59, 118)

7. MIDI

MIDI THRU connector

Musical data and sound settings etc. that are received at the MIDI IN connector are re-transmitted without change from the MIDI THRU connector. You can use this to connect multiple MIDI devices (PG p.258).

MIDI OUT connector

Musical data and sound settings etc. are transmitted from this connector. Use this to control another MIDI device connected via this port to the TRITON STUDIO (PG p.258).

MIDI IN connector

Musical data and sound settings etc. are received at this connector. Use this to play the TRITON STUDIO from another MIDI device connected to this port (PG p.258).

8. DAMPER jack

An optional switch-type pedal such as the Korg DS-1H damper pedal can be connected here. If a DS-1H is connected, it will function as a half-damper pedal. If another switch-type pedal is connected, it will function as a damper switch. In order to ensure that the pedal functions correctly, please adjust the polarity and the half-damper sensitivity (p.11, PG p.137, 146).

9. ASSIGNABLE

SWITCH jack

An optional on/off foot switch such as the Korg PS-1 foot switch can be connected here (p.11). Its function can be assigned in Global mode, allowing you to use the foot switch as a modulation controller, to select

programs or combinations, or to start/stop the sequencer (p.125).

PEDAL jack

An optional Korg EXP-2 or XVP-10 expression pedal can be connected here (p.11). Its function can be assigned in Global mode, allowing you to use the pedal to control the volume etc. (p.124)

10. [Contrast adjustment] knob

This adjusts the contrast of the LCD screen. The optimal setting will depend on the height or angle from which you view the screen display, so please adjust as necessary.

11. EXB-DI (option)

OUT jack

This is an ADAT optical format digital output connector. It outputs the six channels of the TRITON STUDIO's AUDIO OUTPUT jacks (MAIN) L/MONO, R, (INDIVIDUAL) 1, 2, 3, 4 (analog audio outputs) as digital audio with a sampling rate of 48 kHz. These signals are output as channels 1 through 6 of the ADAT optical format. By connecting this to the DIGITAL IN jack of an ADAT Optical format compatible mixer, amp, or recorder, you can output the audio signal of the TRITON STUDIO in digital form. Use an optical cable made by the Alesis Corporation or an optical cable for CD/DAT (both sold separately) to make this connection (p.11, PG p.286, 300). The [VOLUME] slider does not adjust the output level of this connector.

48 kHz WORD CLOCK IN jack

Connect this to the WORD CLOCK OUT jack of an ADAT Optical format compatible mixer or remote controller. Use this when you want the connected device to be the word clock master and the TRITON STUDIO to be the word clock slave for synchronization. Use an BNC coax cable made by the Alesis Corporation or a video BNC cable (both sold separately) to make this connection.

12. EXB-mLAN (option)

A special cable is used to connect mLAN-compatible devices or computers. (p.12, PG p.286)

mLAN (IEEE 1394) 1, 2, 3 jacks

SERIAL I/O connector

For details refer to the manual included with the EXB-mLAN option.

What is mLAN?



mLAN is a new standard for musical instruments that uses the general-purpose IEEE 1394 ("FireWire") interface (a general-purpose interface with a wide range of uses including current and digital AV devices) with a special transmission protocol for musical data. It allows high quality digital audio and MIDI data to be simultaneously transmitted and received over a single cable. At a transmission speed of 200 Mbps, approximately 100 channels of audio data or 256 ports of MIDI data (i.e., 16 channels x 256 connectors) can be transmitted and received over a single cable. mLAN provides unprecedented flexibility, allowing you to daisy-chain up to 63 devices, and even to reconfigure the input and output connections between devices without actually disconnecting the mLAN cable. Even sophisticated setups in the studio or on stage are made easy by mLAN.

Names and functions of objects in the LCD screen

The TRITON STUDIO uses Korg's TouchView graphical user interface. By touching on objects displayed in the LCD screen, you can select pages, set parameter values, rename programs and combinations, write data, and perform many other operations.

note References in the TRITON STUDIO's owner's manual to the "... button" or "... tab" refer to objects displayed on the LCD screen. References to the "[...] key," "[...] knob," "[...] dial," or "[...] slider" refer to controls on the front or rear panel of the TRITON STUDIO.

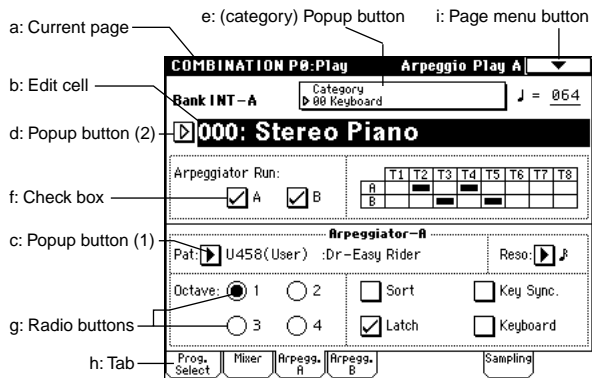

a: Current page

This indicates the selected page within the current mode. From the left, this shows the mode name, page number, and page name.



b: Edit cell

When you press a parameter in the LCD screen, the parameter or parameter value will sometimes be highlighted (displayed in inverse video). This is called the **edit cell**, and the highlighted item will be subject to editing. The parameter value of the edit cell can be modified using the VALUE controllers (see p.17) or by using a popup button in the LCD screen. For parameters that accept a note number or a velocity value, you can also hold down the [ENTER] key and play a note on the keyboard to enter the note number or velocity value.

c: Popup button (1)

When this button is pressed, a popup menu will appear, showing the parameter values that are available for selection.

To input the parameter value, press the desired value in the popup menu.

When a popup menu is displayed, operating a VALUE controller (see p.17) will close the popup menu. If the popup menu is unlocked (see "Pin"), it will close if you touch a location outside the popup menu.

* Popup menu

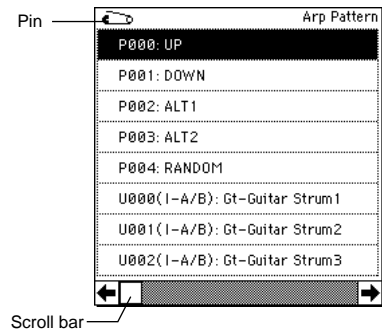

Pin

This switches the popup menu display between **locked** and **unlocked**.

When locked, the pin will be shown closed, and the popup menu will remain displayed even after you press a parameter value. When unlocked, the pin will be shown opened, and the popup menu will close immediately when you press a parameter value.

Scroll bar

Use this when you wish to see parameter values that extend beyond what can be displayed in the screen at one time.

Press here to scroll to left or right.



Press here and slide to left or right to scroll to the desired location.

Press here to scroll to the corresponding location.

d: Popup button (2)

When you press this button, a tabbed **popup menu** will appear, allowing you to perform the following selections.

- "Bank/Program Select," "Bank/Combination Select": Select programs or combinations by bank
- "Multisample Select": Select a multisample for a program oscillator by category (ROM multisamples only)
- "Category/Effect Select": Select an insert effect or master effect by category
To close the tabbed popup menu, press the OK button or Cancel button.

e: (Category) popup button

When you press this button, a tabbed **popup menu** will appear, allowing you to perform the following selections.

- "Category/Program Select," "Category/Combination Select": Select programs or combinations by category
To close the tabbed popup menu, press the OK button or Cancel button.

f: Check box

Each time you press a check box, a check mark will be added or removed.

When checked, the parameter will function; when unchecked, the parameter will not function.

g: Radio buttons

Press a radio button to select one value from two or more choices.

h: Tab

Press the tab to select a page.

i: Page menu button

When this button is pressed, a list of **page menu commands** will appear.

The page menu commands that appear will depend on the currently selected page.

You can also select up to ten page menu commands by holding down the [ENTER] key and pressing a numeric key [0]–[9].

The page menu will close when you press the LCD screen at a location other than the page menu, or when you press the [EXIT] key.

*** Dialog box**

The dialog box that appears will depend on the currently selected page menu command.

When selecting a program or combination number in a dialog box, use the VALUE controllers (see p.17) to input the number.

To execute, press the OK button. To cancel without executing, press the Cancel button. (The operation will occur when you press and release the button.) The dialog box will close. The [EXIT] key corresponds to the Cancel button, Done button, and **Exit button**.

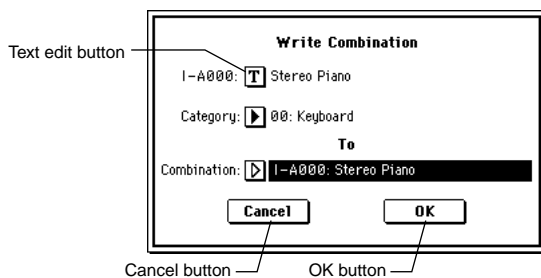

After some commands are executed, the previously-locked page menu will be unlocked automatically, and the page menu will be closed.

*** Text edit button**

When you press this button, a text edit dialog box will appear.

Here you can rename text (such as the name of a program, combination, or song etc.) (see p.40, 57).

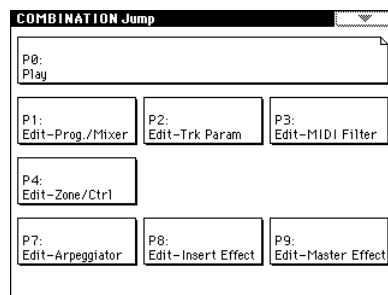
*** Page jump menu**

In Combination, Program, Sequencer, Sampling, Song Play, or Global modes, you can press the front panel [MENU] key to view a list of the pages in that mode. (As a reminder, the page you were in before you pressed the [MENU] key will have its top right corner bent over.) By pressing one of the pages shown, you can move to that page. (You can also move to the corresponding page by pressing a numeric key [0]–[9].)

When you press the [EXIT] key, P0 will be displayed.

*** Other objects**

To modify the parameter value of an object shaped like a slider or knob, press it to move the edit cell to that object, and use the VALUE controllers to modify the value. In addition, there are also buttons similar to the OK button and Cancel button explained in “* dialog box” which execute an operation when they are pressed and released, such as the Done button, Copy button, and Insert button.

Toggle buttons

This type of button will change its function or switch on/off each time it is pressed.



PLAY/MUTE/REC button in Sequencer and Song Play mode



SOLO ON/OFF button in Sequencer and Song Play mode



ON/OFF button for Insert Effect and Master Effect

Connections

⚠ Connections must be made with the power turned off. Please be aware that careless operation may damage your speaker system or cause malfunctions.

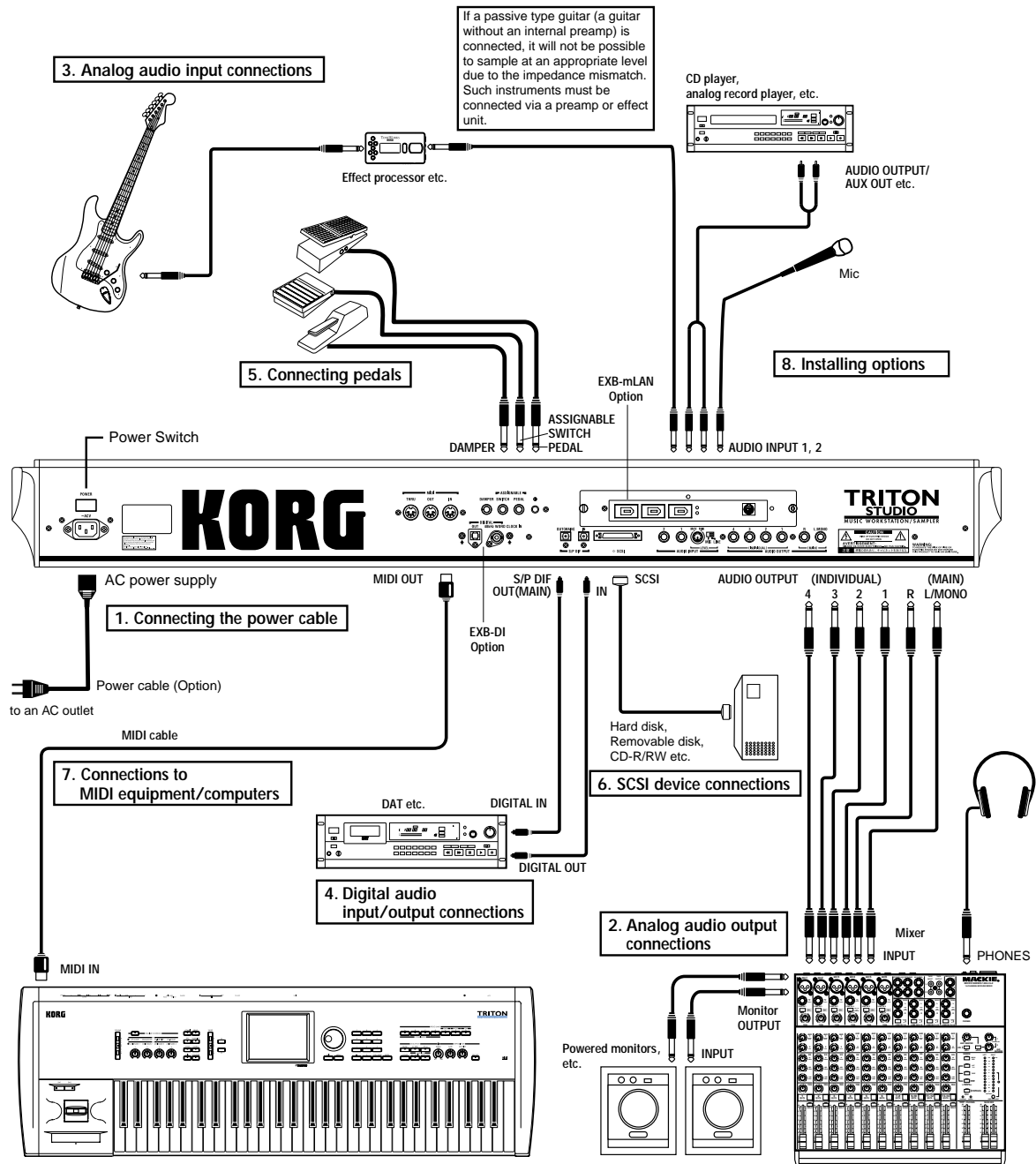

1. Connecting the power cable

- Connect the included power cable to the AC power supply inlet of the TRITON STUDIO, and then connect the other end of the cable to an AC outlet.

2. Analog audio output connections

Connect a set of amplified monitor speakers or your audio system to the TRITON STUDIO.

- ▲ If you play back the TRITON STUDIO through your stereo audio system, be aware that high volumes may damage your speakers. Be careful not to raise the volume excessively.

- **Connecting the AUDIO OUTPUT (MAIN) L/MONO, R, (INDIVIDUAL) 1, 2, 3, and 4 jacks to the INPUT jacks of your mixer or powered monitor system.**

L/MONO and R are the main outputs. If you are outputting in stereo, make your connections using the (MAIN) L/MONO jack and the R jack. If you are outputting in mono, make your connection to the (MAIN) L/MONO jack.

The (INDIVIDUAL) 1, 2, 3, and 4 jacks are used to output specific sounds independently. For example, you can use these to apply an external effect to the snare sound of a drum kit.

When you are sampling, and want to hear the sounds played by the TRITON STUDIO's sequencer while you sample only the external audio source, send the source to (INDIVIDUAL) 1 and 2. If you want to monitor this sound, you can connect (INDIVIDUAL) 1 and 2 jacks to your mixer, and monitor the sound via your mixer. (☞ For details on routing methods, refer to p.140-)

Headphones

- **If you are using headphones, connect them to the headphone jack of the TRITON STUDIO.**

The TRITON STUDIO's headphone jack will output the same signal as (MAIN) L/MONO and R.

- note If you are using (INDIVIDUAL) 1, 2, 3, and 4, connect these jacks to your mixer, and use the headphone jack of your mixer to monitor the sound.

3. Analog audio input connections

You can input external analog audio sources, and sample them or process them with the internal effects and output them from the OUTPUT jacks.

- **Connect mics or the OUTPUT jacks of your external audio equipment to the AUDIO INPUT 1 and 2 jacks.**

4. Digital audio input/output connections

Digital audio output

The same audio signal present at the TRITON STUDIO's AUDIO OUTPUT (MAIN) L/MONO and R jacks can be output in digital format to a DAT, MD, or digital multi-track recorder that can accept a digital audio input with a sample frequency of 48 kHz or 96 kHz.

- **Use an optical cable to connect the S/P DIF OUT (MAIN) jack to the optical digital input jack of your DAT, MD, or digital multitrack recorder.**

- ▲ The [VOLUME] slider does not affect the volume of this output jack.

Digital audio input

TRITON STUDIO can accept a digital audio input from a DAT or other digital device that can output digital audio at a sampling frequency of 48 kHz or 96 kHz. This signal can be input to the L and R channels, then sampled or processed by the internal effects and output from the OUTPUT jacks.

- **Use an optical cable to connect the optical digital output jacks of your DAT etc. to the S/P DIF IN jack.**

- note If the EXB-mLAN option is installed, digital audio can be input/output via the mLAN connector. If the EXB-DI option is installed, digital audio can be output via the DIGITAL OUT jack. (☞ PG p.286)

5. Connecting pedals

Foot pedal connections

A foot pedal can be used to control various synthesis and effect parameters.

Connect an optional expression pedal such as the Korg XVP-10 or EXP-2 to the rear panel ASSIGNABLE PEDAL jack.

The function controlled by the foot pedal is specified in Global: P2 "Foot Pedal Assign" (☞ p.125, PG p.146, 252)

Foot switch connections

A foot switch controls sostenuto, soft pedal on/off, arpeggiator on/off, to select programs or combinations, and to start/stop the sequencer etc.

Connect an optional foot switch such as the Korg PS-1 to the rear panel ASSIGNABLE SWITCH jack.

The function assigned to the foot switch and the polarity of the foot switch can be set in Global: P2 "Foot Switch Assign," and "Foot Switch Polarity" (☞ p.125, PG p.146, 251)

Damper pedal connections

This pedal applies a piano style damper effect as you play. Connect an optional footswitch to the DAMPER jack of the TRITON STUDIO. If a Korg DS-1H is connected, half-damper effects can be produced.

The polarity of the pedal is set in Global P2: Controller "Damper Polarity" and the sensitivity is set in Global P0 "Half Damper Calibration." (☞ PG p.137, 146)

6. SCSI device connections

By connecting an external SCSI device such as a hard disk drive or CD-R/RW drive to the SCSI connector, you can manage large amounts of data on devices other than the internal hard drive. If a hard disk drive is connected, it can also be specified as the destination when sampling.

☞ For details on connecting SCSI devices, refer to PG p.298.

About SCSI devices that can be used with the TRITON STUDIO

- To store data, the TRITON STUDIO can use either DOS-formatted SCSI disks or UDF-formatted CD-R/RW discs.
 - In some cases it will not be possible to use a DOS-format or UDF-format disk that was formatted on a personal computer. As far as possible, please use the TRITON STUDIO to format the disc.
 - The TRITON STUDIO can use MO disks of 128 Mbytes, 230 Mbytes, 540 Mbytes, 640 Mbytes, and 1.3 Gbyte capacities.
-

7. Connections to MIDI equipment/computers

Connections to MIDI equipment

The keyboard, controllers, and sequencer etc. of TRITON STUDIO can be used to control an external MIDI tone generator. Conversely, another MIDI keyboard or sequencer can control the tone generator of TRITON STUDIO to produce sound.

- Use MIDI cables to connect the MIDI connectors of TRITON STUDIO with the MIDI connectors of your external device.

☞ PG p.258 "MIDI applications – Connecting MIDI devices/computers"

Connections to a computer

Your performance on the TRITON STUDIO, as well as controller and sequencer data, can be sent to a computer (connected via MIDI interface), and the tone generator of TRITON STUDIO can be played from the computer.

- Use a MIDI interface to connect the MIDI connectors of TRITON STUDIO to the MIDI connectors of your computer.

☞ PG p.258 "MIDI applications – Connecting MIDI devices/computers"

⚠ Some USB-MIDI interfaces may not be able to transmit or receive the TRITON STUDIO's MIDI exclusive messages.

 If the EXB-mLAN option is installed, MIDI messages can be exchanged via the mLAN connector between the TRITON STUDIO and an external mLAN-compatible MIDI device or a FireWire-capable Macintosh computer. For details on connections, refer to the "EXB-mLAN owner's manual" included with the EXB-mLAN option.

⚠ At present, a TRITON STUDIO MIDI data dump sent via the EXB-mLAN option to a computer cannot be recorded or played back by an OMS-compatible application. (The same applies to the TRITON-Rack.)

8. Installing options

The functionality of the TRITON STUDIO can be extended by installing option boards and/or sample memory. The following six types of options can be installed. For details on installation, refer to PG p.286.

- EXB-MOSS (DSP synthesizer board)
- EXB-DI (Digital interface board)
- EXB-mLAN (mLAN interface board)
- CDRW-1 (CD-R/RW drive)
- EXB-PCM series (PCM expansion boards)
- DRAM SIMM (Memory boards for sample data)

Basic concepts

Overview of the modes

The TRITON STUDIO has a large number of functions that let you play and edit programs and combinations, record and play sequence data, record and play back samples, and manage data on disk. The largest unit used to organize these functions is called a mode. The TRITON STUDIO has seven modes.

Program mode

- Select and play programs
You can choose programs from rewritable banks INT-A-INT-F and EXB-A-EXB-G which contain a total of 1,664 programs, and non-rewritable bank INT-G (256 programs compatible with the GM2 standard, and nine drum programs).
(The 128 programs of bank INT-F can be selected only if the EXB-MOSS option has been installed.)
- Sample or resample.
For example you can sample an external audio source while listening to the performance of the arpeggiator, or resample a performance you play using a program.
- Edit a program
Make settings for the oscillator, filter, amp, EG, LFO, effects, and arpeggiator.

The following multisamples are available for the oscillator.

- 429 internal multisamples (ROM, Piano)
- Expanded multisamples (when one or more EXB-PCM series board are installed)
- Multisamples (RAM) that you sampled on the TRITON STUDIO or loaded in from media
- Create drum programs using a drum kit (created in Global mode)

Combination mode

- Select and play combinations
A combination is a set of two or more programs (a maximum of eight), and allows you to produce complex sounds that could not be created by an individual program.
You can choose combinations from rewritable banks INT-A-INT-E and EXB-A-EXB-G which contain a total of 1,536 combinations.
- Sample or resample.
For example you can sample an external audio source while listening to the performance of the arpeggiators, or resample a performance you play using a combination.
- Edit a combination
Make settings for volume, pan, layer/split etc. for each timbre (program), and make settings for effects and the two arpeggiators.

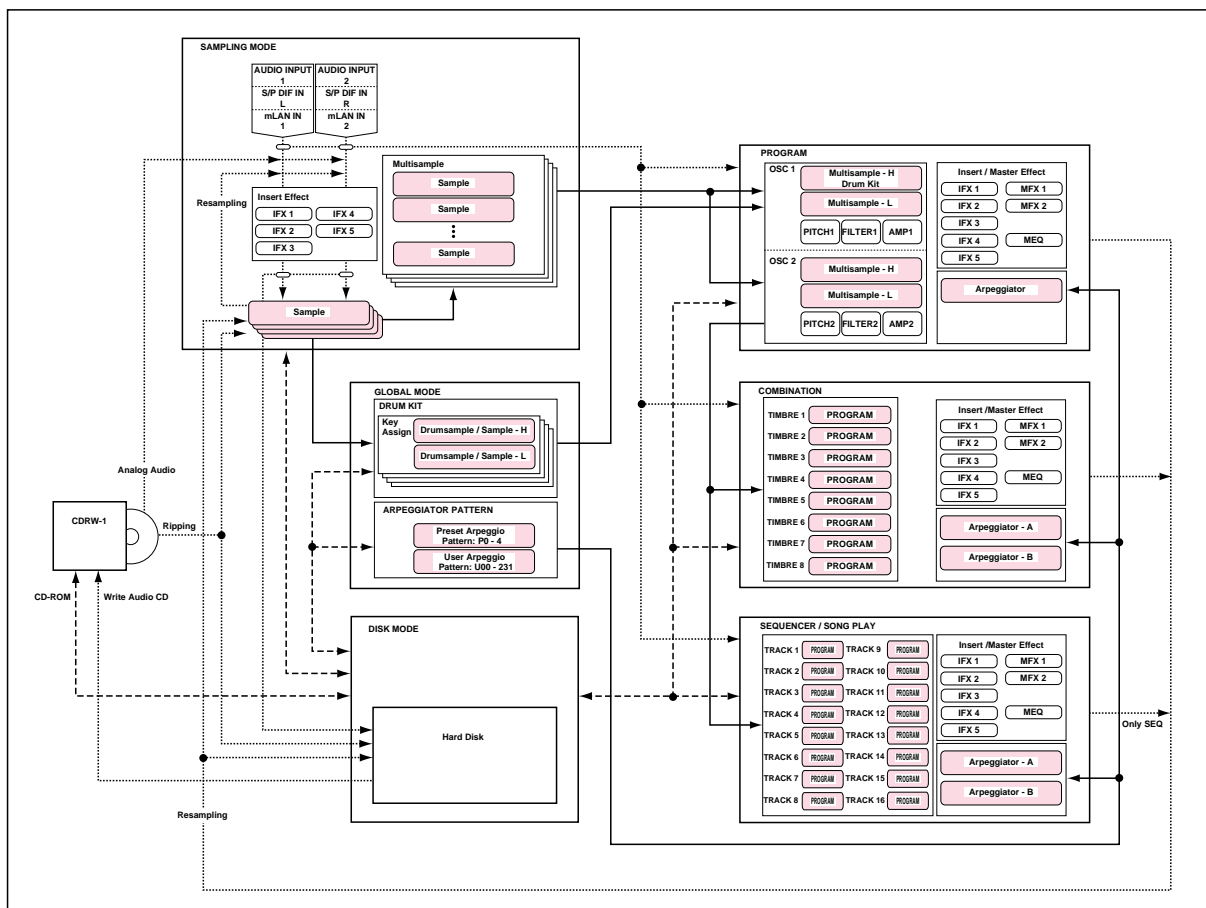

Sequencer mode

- Use the 16-track sequencer to record and playback songs.
- Sample or resample.
You can sample an external input source while listening to the song playback. You can also cause a corresponding note event to automatically be created at this time, allowing you to sample an external source just as if you were recording an audio track. (The In-Track Sampling function.)
The playback of a song can also be resampled. After resampling one or more songs to the hard disk, you can use Disk mode to create an audio CD from those songs.
- Make effect settings for the song.
- You can record a performance that uses the arpeggiator(s) into a song or pattern.
- You can use a cue list to create an arrangement using individual songs for each verse, chorus, bridge, etc., and specify the number of repeats for each song.
- You can use a maximum of 20 cue lists, 200 songs, and 100 preset patterns. One song can use as many as 100 patterns.
- The TRITON STUDIO can be used as a 16-track multitimbral tone generator.
- Record patterns and assign them to individual keys, using the RPPR (Realtime Pattern Play/Recording) function.
- Perform using the RPPR (Realtime Pattern Play/Recording) function, and adjust the various settings.

Song Play mode

- SMF (Standard MIDI File) data can be played back from a floppy disk, the internal hard drive, or an external SCSI device, and you can perform along with the playback.
- Make effect settings for use in Song Play mode.
- The arpeggiator can be used while you play along with the SMF playback.
- SMF songs can be played back in succession.
You can use the jukebox function to playback songs in any specified order.

Sampling mode

- Sample external audio sources (i.e., record samples).
Insert effects can be applied to the external input sound while you sample.
- Edit the waveform data you sampled or waveform data that you loaded in from media, and set loop points etc.
- Edit multisamples consisting of two or more samples.
- A multisample can be converted into a program, so that a multisample created in Sampling mode can be used in the Program, Combination, Sequencer, or Song Play modes.
- Sample digital data ("rip") directly from an audio CD.
You can also play back audio CDs.

Global mode

- Make settings that affect the entire TRITON STUDIO, such as master tune and global MIDI channel.
- Create user drum kits (144 kits), user arpeggio patterns (507 patterns), and user scales (16 one-octave scales and 1 all-note scale).

- Create drum kits using the 417 internal drumsamples (ROM). You can also use drumsamples from an optional EXB-PCM series board (if installed), or samples (RAM) that you created in Sampling mode.
- Rename program and combination categories.
- Set the function of the assignable pedals and assignable switches.
- Transmit data dumps of MIDI exclusive data.

Disk mode

- Data of each mode can be saved and loaded using the floppy disk drive, the internal hard drive, the CDRW-1 option or an external SCSI device.
- Format the above types of media. You can also manage data by copying it, etc.
- Korg, AKAI, AIFF, and WAVE format sample data can be loaded. Sample data can also be saved in Korg format, or exported in AIFF or WAVE formats.
- Songs that you created in Sequencer mode can be saved in SMF format. SMF files can be loaded as Sequencer mode songs.
- You can use the Data Filer function (to save/load MIDI exclusive data).
- WAVE files can be edited (arranged in the desired song order) to create an audio CD. Audio CDs can also be played.

About polyphony

Tone generators and oscillators

The oscillators of the TRITON STUDIO are sounded by two Tone Generators.

Each tone generator is connected to the various PCM memories as shown in the diagram below.

Tone Generator 1

- **ROM:** Internal PCM ROM (32 Mbytes)
- **RAM:** User sample memory (16 Mbytes, expandable to a maximum of 96 Mbytes)

Tone Generator 2

- **Piano:** Internal Piano PCM ROM (16 Mbytes)
- **EXB-PCM:** Expansion PCM ROM (16 Mbytes each; maximum of 7 boards totaling 112 Mbytes)

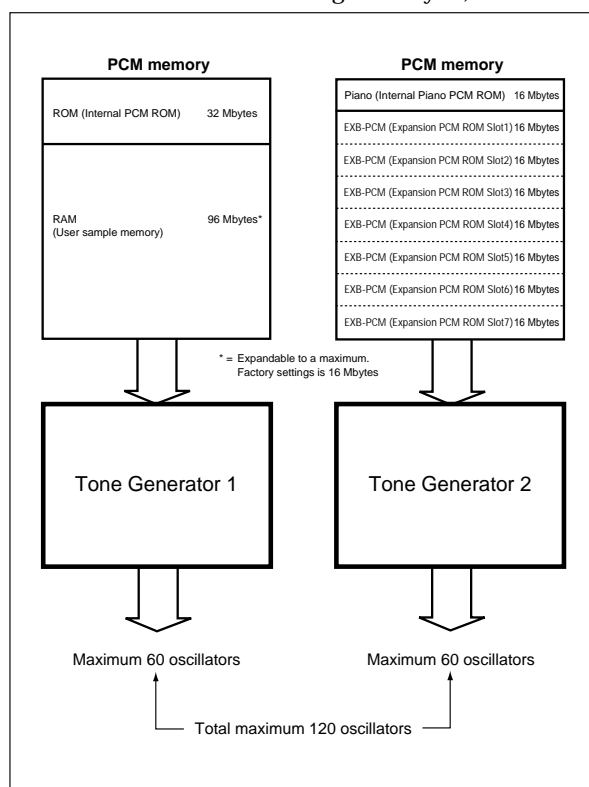

Each tone generator is able to simultaneously sound up to 60 oscillators (i.e., to play the PCM data connected to that tone generator). Together, the two tone generators are able to sound up to 120 oscillators.

However, it is not possible, for example, to simultaneously play 61 or more oscillators from only the internal PCM ROM.

Number of voices in each mode

The maximum number of voices that can be played simultaneously will depend on the oscillator mode of the program.

- For a Single/Drum-mode program, 1 oscillator = 1 voice
- For a Double-mode program, 2 oscillators = 1 voice

Program mode

Single/Drum-mode

Normally, 60 voices can be used.

However a maximum of 120 voices will be available if, for example, ROM or RAM is used for the High MS, and Piano or EXB-PCM is used for the Low MS, and you use velocity switching to play the two tone generators.

Double mode

Normally, 30 voices can be used.

However if OSC1 is sounded by one tone generator and OSC2 is sounded by the other tone generator (e.g., OSC1=ROM, OSC2=Piano), a maximum of 60 voices can be used. If OSC1 and OSC2 use one tone generator (e.g., OSC1=ROM, OSC2=ROM), then a maximum of 30 voices can be used.

This can also be increased by velocity switch and velocity zone settings.

Combination, Sequencer, and Song Play modes

Depending on the oscillator mode of the programs you are using, the maximum number will vary between 60 voices and 120 voices.

(Example)

For single-mode programs that use ROM or RAM, a total maximum of 60 voices

For single-mode programs that use Piano or EXB-PCM, a total maximum of 60 voices

Total 120 voices

For double-mode programs that use ROM or RAM, a total maximum of 30 voices

For double-mode programs that use Piano or EXB-PCM, a total maximum of 30 voices

Total 60 voices

Sampling mode

Tone generator 1 is always used in Sampling mode.

Mono samples/multisamples

60 voices.

Stereo samples/multisamples

30 voices.

Basic operation

1. Selecting modes

○ In order to use a particular function on the TRITON STUDIO, you must first select the appropriate mode. Press one of the front panel mode keys ([COMBI] key - [DISK] key) to enter the corresponding mode.

- [COMBI] key: Combination mode
- [PROG] key: Program mode
- [SEQ] key: Sequencer mode
- [SAMPLING] key: Sampling mode
- [S.PLAY] key: Song Play mode
- [GLOBAL] key: Global mode
- [DISK] key: Disk mode

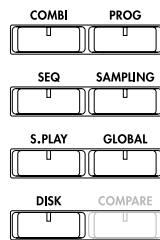

2. Selecting pages

Each mode has a large number of parameters, which are grouped into pages. These are further subdivided by tabs into up to eight tab pages.

① Make sure that the desired mode is selected.

To select a mode, press the appropriate mode key ([COMBI] key - [DISK] key). Here we will use Program mode as an example for our explanation. Press the [PROG] key.

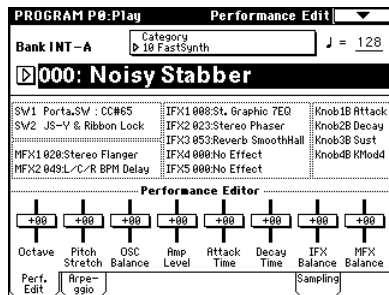

② Press the [MENU] key.

The page jump menu will appear.



note In Disk mode there is only one page, so the page jump menu will not appear.

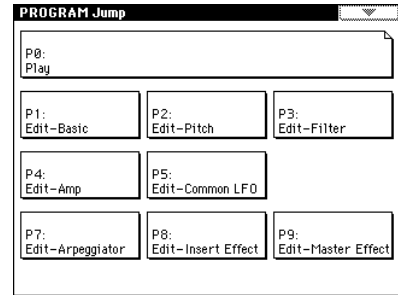

③ In the LCD screen, press the desired page.

You will jump to the selected page, and it will appear in the display. As an example here, press P1: Edit-Basic.

- As a reminder, the page that was selected before you pressed the [MENU] key will have its top right corner bent over.
- You can also jump to the corresponding page by pressing a numeric key [0]-[9]. (P0-P9 correspond to numeric keys [0]-[9].)
- By holding down the [MENU] key and pressing a numeric key [0]-[9], you can jump directly to the corresponding page without displaying the page jump menu.

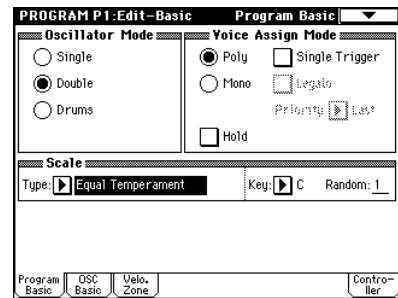
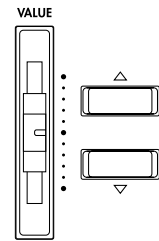

note When you press the [EXIT] key, you will return to P0 from any page.

④ Press one of the tabs located at the bottom of the page.

As an example here, press the OSC Basic tab which is the second from the left.

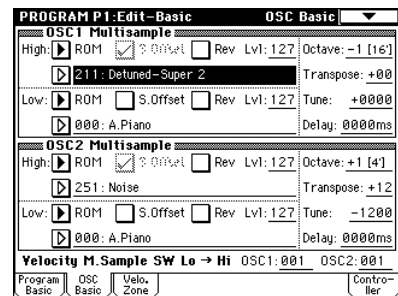

• Some pages have no tabs.

⑤ To move to a page with a different 'P' number, press the [MENU] key and continue from step ② of this procedure.

3. Setting a parameter

The parameter value in the edit cell can be set by using the front panel **VALUE controllers** ([VALUE] slider, [△][▽] keys, [VALUE] dial, numeric keys [0]–[9], [-] key, [ENTER] key, and [./10's HOLD] key). As necessary, you can also use the [BANK] keys and the [COMPARE] key. For some parameters, the value can be set by pressing a popup button to display the popup menu and then selecting a parameter value, or by holding down the [ENTER] key and playing a note on the keyboard to input a note number or velocity value.

VALUE controllers

[VALUE] slider

Use this when you wish to make major changes in the value.

In Program mode and Combination mode, this slider can also be used as a control source for alternate modulation or dynamic modulation. (This is active in Program or Combination P0: Play when the "Program Select" or "Combination Select" (the large characters in the upper part of the LCD) is selected).

[△][▽] keys

Use these when you wish to make small changes in the value.

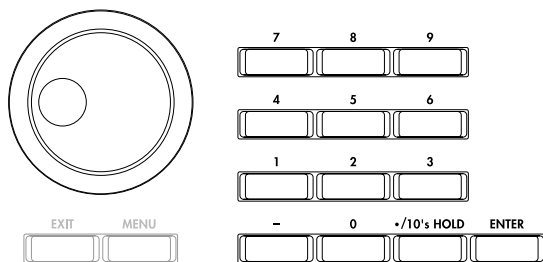

[VALUE] dial

Use this when you wish to make large changes in a value.

Numeric keys [0]–[9], [ENTER] key, [-] key, [./10's HOLD] key

Use these when you know the parameter value that you wish to input.

After using the numeric keys [0]–[9] to input a number, press the [ENTER] key to finalize the parameter value.

Use the [-] key to enter negative numbers.

Use the [./10's HOLD] key to enter a decimal point.

In Program and Combination mode P0: Play page other than the Sampling page, the [./10's HOLD] key performs the 10's Hold function. (p.23, 24)

BANK [INT-A]–[INT-G], [EXB-A]–[EXB-G] keys

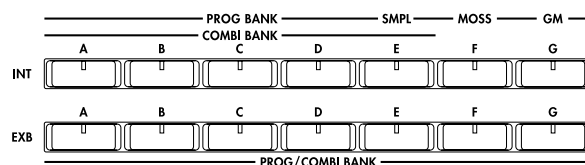

The BANK [INT-A]–[INT-G], [EXB-A]–[EXB-G] keys are used in Program mode to select the program bank and in Combination mode to select the combination bank. In combination, Sequencer and Song Play modes, these keys are used to select the bank of the program used by each timbre/track.

[COMPARE] key



Use this key when you wish to compare the edits you have made to a program or combination's sound with the un-edited original (i.e., the sound that is written into memory).

When editing a **program** or **combination**, press this key. The LED will light, and the last-written settings for that program number or combination number will be recalled. When you press the [COMPARE] key once again, the LED will go dark and you will return to the settings that you were editing.

If you edit the settings that are recalled by pressing the [COMPARE] key (i.e., the settings that are written into memory), the LED will go dark, and it will not be possible to return to the previous edits by pressing the [COMPARE] key again.

In **Sequencer mode**, you can use the [COMPARE] key to make "before and after" comparisons immediately after using realtime recording or step recording to record a song, or after performing a track edit operation. For example, this can be used effectively when realtime-recording a track for a song.

- ① Realtime-record a track. (Take 1)
- ② Once again, realtime-record on the same track. (Take 2)
- ③ Press the [COMPARE] key. The LED will light, and take 1 will be recalled.
- ④ Press the [COMPARE] key once again. The LED will go dark, and take 2 will be recalled.
- ⑤ If at step ③ you once again realtime-record on the same track (take 3), the object of the Compare function will now be take 1. If at step ④ you once again realtime-record on the same track (take 3), the object of the Compare function will be take 2.

In this way, the Compare function lets you recall the previous recording or the previous state of event editing.

⚠ The Compare function is not available Sampling, Song Play, Global, or Disk modes.

Popup buttons and popup menus

You can press a popup button to access a popup menu, and then set parameter values (see p.8).

Keyboard input

When inputting a note number or a specific velocity as the value of a parameter, you can use the keyboard to input the setting. Hold down the [ENTER] key and play the note that you wish to enter as a value. The note number or velocity value will be input.

When the Global P5: Drum Kit page is displayed, you can hold down the [ENTER] key and play a note to recall the settings that have been assigned to that note.

In Sampling mode, you can hold down the [ENTER] key and play a note to recall the index that is assigned to that note.

Quick Start

Turning the power on/off

- Before you turn on the power, make sure that the desired connections have been made as described in "Connections" (p.10).

1. Turning the power on

- Press the rear panel [POWER] switch to turn on the power.

The LCD screen will display the name of your model, and the software version.

(The following graphic shows the factory-set LCD screen. The version number is subject to change without notice.)

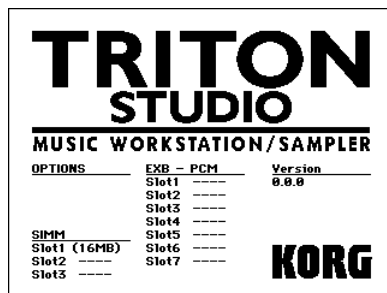

- Turn on your powered monitors or stereo amp.
- Raise the TRITON STUDIO's [VOLUME] slider to an appropriate level, and adjust the volume of your powered monitors or stereo amp.

- If an external SCSI device is connected, turn on the power of the external SCSI device and then wait ten seconds or longer before you turn on the power of the TRITON STUDIO.

2. Turning the power off

- Set the front panel [VOLUME] slider and the volume of your powered monitor or stereo amp to zero.
- Turn off the power of your powered monitor or stereo amp.
- Press the TRITON STUDIO's [POWER] switch to turn off the power.

- Never turn off the power while data is being written into internal memory. If the power is turned off while processing is being performed, memory write operations will not be completed correctly. If this occurs, TRITON STUDIO will automatically initialize its internal memory so that it will operate correctly. This is not a malfunction.

While data is being written, the LCD screen will indicate "Now writing into internal memory." Data is written into internal memory by the following operations.

- Writing (updating) a Program, Combination, Global Setting, Drum Kits, or Arpeggio Patterns
- Loading Program, Combination, Global Setting, Drum Kit, or Arpeggio Patterns data in Disk mode
- Receiving a MIDI data dump for Program, Combination, Global Setting, Drum Kit, or Arpeggio Patterns
- When using Sampling mode page menu commands ("Move Sample," "Move MS," "Convert To Program," "Time Slice," etc.) to simultaneously modify programs or drum kits.
- When sampling to RAM in Program, Combination, or Sequencer mode, if you simultaneously convert the sample to a program.

- Never turn off the power while the hard disk or other media is being accessed. If you turn off the power while media is being accessed, the media may become unusable.

note You can set the "Power On Mode" (Global P0: System Preference page) so that the mode and page that had been selected when you turned the power off will appear when the power is turned on. (p.125)

Information displayed in the LCD screen when various options or SIMM modules are installed

The TRITON STUDIO allows you to install separately sold options or sample memory (RAM) boards. When the power is turned on, the type of installed options will be displayed. After installing an option, be sure to check this display to verify that the option was installed correctly. If the option is not displayed here even though it was installed, it was not installed correctly. Turn off the power and re-install the option. (For details on installing an option, refer to PG p.286)

OPTIONS

CDRW-1: The CDRW-1 option is installed.

EXB-MOSS: The EXB-MOSS option is installed.

EXB-DI: The EXB-DI option is installed.

EXB-mLAN: The EXB-mLAN option is installed.

SIMM

Slot 1...3 (MB):** Sample memory (RAM)'s are installed in SIMM slots 1-3. The capacity of each SIMM is shown in parentheses. When shipped from the factory, a 16 MB SIMM is installed in SIMM slot 1.

EXB-PCM

Slot 1...7 (**):** PCM expansion boards are installed in EXB-PCM series slots 1-7. The model number of each board is shown in parentheses.

OPTIONS	EXB - PCM
CDRW - 1	Slot1 (EXB1)
EXB - MOSS	Slot2 (EXB2)
EXB - DI	Slot3 (EXB3)
EXB - mLAN	Slot4 (EXB4)
SIMM	Slot5 (EXB5)
Slot1 (16MB)	Slot6 (EXB6)
Slot2 (32MB)	Slot7 (EXB7)
Slot3	

Listening to a demo song

Here's how to listen to demo songs on the TRITON STUDIO.

This section explains how the demo song data can be loaded from the internal hard drive using the Disk mode, and played back in Sequencer mode.

We will explain how to play back songs individually, or consecutively using the Cue List function.

1. Loading the demo song data in Disk mode

- ① Press the [DISK] key (the LED will light).
You will enter Disk mode.
- ② Press the Load tab.
The Disk, Load page will appear.
- ③ Press the drive select popup button, and select HDD: (internal hard drive) which is the second from the bottom in the popup menu.
File information for the internal hard disk will be displayed.
- ④ Press the FACTORY directory, and then press the Open button.
You will move to the next lower directory.
- ⑤ Press "PRELOAD.SNG."
The display will be highlighted. This is the demo song data.

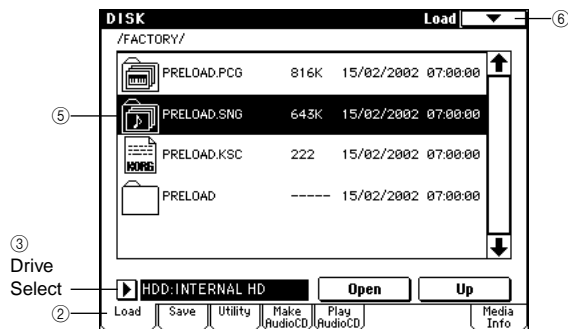

- ⑥ Press the page menu button.
The page menu commands will be displayed.

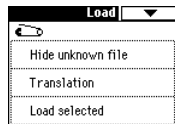

- ⑦ Press "Load selected."
A dialog box will appear.

- ⑧ Check the data that you want to load along with the song.

In this case, make the settings shown below.

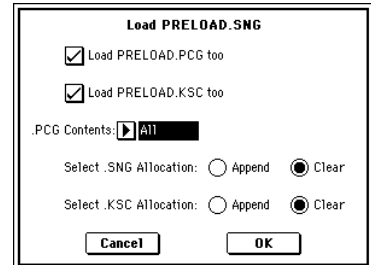

- Check "Load PRELOAD.PCG too"
If this is checked, the .PCG file will be loaded along with the .SNG file when you execute the Load operation.
- Check "Load PRELOAD.KSC too"
If this is checked, the .KSC file will be loaded along with the .SNG file when you execute the Load operation.

The "Select .SNG Allocation" radio buttons specify how the song data will be loaded into internal memory. For this example, select **Clear**.

The "Select .KSC Allocation" radio buttons specify how the sample data will be loaded into sample memory (RAM). For this example, select **Clear**.

If you load with "Select .KSC Allocation" set to Clear, the sample data will be loaded from the beginning of the sample memory (RAM) area.

If you load with "Select .KSC Allocation" set to Append, the sample data will be loaded into the unused portion of the sample memory (RAM).

- ⚠ If sample memory (RAM) already contains sample data that you do not wish to lose, either select **Append**, or save the sample data to a internal hard disk (p.59).

- ⑨ Press the OK button.

The data will be loaded in the order of PRELOAD.PCG, PRELOAD.SNG, and PRELOAD.KSC.

2. Selecting and playing a demonstration song in Sequencer mode

- 1 Press the [SEQ] key (the LED will light).

You will enter Sequencer mode.



- 2 Access the P0: Play/REC, Program T01-08 page.
If this is not already displayed, press the [EXIT] key and then press the Prog. 1-8 tab.
- 3 Select the demonstration song that you want to play back.
Press the "Song Select" area to highlight the song name.
Use the numeric keys to input a song number, and press the [ENTER] key.
For example to select the second song, press numeric key [1] and then press the [ENTER] key. (Song "S001" will be selected.)
Alternatively, you can select a song from the popup menu.
Press the "Song Select" popup button to access the popup menu. In the popup menu, press the song that you want to play back. The popup menu will close, and the selected song will be displayed.
- 4 Press the SEQUENCER [START/STOP] key.
The LED will blink and the selected song will play.
- 5 If you wish to stop playback, press the SEQUENCER [START/STOP] key once again.

Playing a cue list

Here's how to playback the demonstration cue list. A cue list allows you to playback multiple songs in succession, and specify the number of times that each song will be repeated.

- 1 Press the [MENU] key.
The LCD screen will show a list of the pages in Sequencer mode.
- 2 Press either "P1: Cue List" or numeric key [1].
The P1: Cue List page will appear.
- 3 Press the SEQUENCER [START/STOP] key.
- 4 To stop playback, press the SEQUENCER [START/STOP] key once again.

If the last step is **End**, playback will stop automatically when it reaches that point. If the last step is **Continue to Step01**, playback will return to the first step and continue.

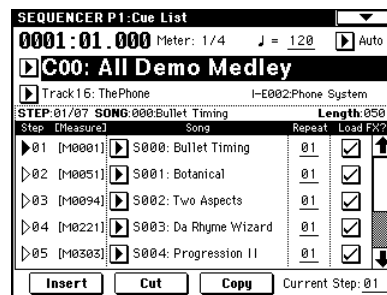

Contents of the disk

The internal hard drive contains the following data. The included TNSFD-00P floppy disk contains the same data as the PRELOAD.PCG file in the internal hard drive.

PRELOAD.PCG

- Preloaded data (programs, combinations, drum kits, arpeggio patterns, global settings)
- Program data (programs using the sampling function) used by the demonstration songs

note When you load PRELOAD.PCG, it will be written into internal memory. This data is preserved even if the power is turned off.

! When you load PRELOAD.PCG, the data existing in the TRITON STUDIO before loading this data will be replaced. If you wish to keep this data, you must first save it before loading PRELOAD.PCG. (p.59)

PRELOAD.SNG

- Demonstration song and demonstration cue list data

note When you load PRELOAD.SNG, it will be written into internal sequencer memory. This memory is volatile, and the data will be lost when the power is turned off.

! Whether or not previously-written data will be erased when you load PRELOAD.SNG is determined by the "Select .SNG Allocation" setting. Refer to step ⑧ of the procedure on p.20.

PRELOAD.KSC

- Sample program data used by the demonstration songs

note When you load PRELOAD.KSC, its multisample/sample data will be written into the TRITON STUDIO's sample memory (RAM). This data will be lost when the power is turned off.

! Whether or not previously-written data will be erased when you load PRELOAD.KSC is determined by the "Select .KSC Allocation" setting. Refer to step ⑧ of the procedure on p.20.

Selecting and playing a program

In Program mode you can select and play a program from banks INT-A–EXB-G. Here we will show how to select preset programs.

Try selecting various programs and hear how they sound.

Selecting a program

- 1 Press the [PROG] key (the LED will light).

You will enter Program mode. Make sure that the upper line of the LCD screen indicates “PROGRAM P0: Play.”

If this is not selected, press the [EXIT] key.

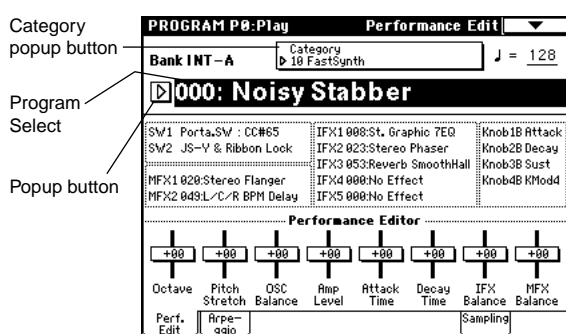

Selecting a program number

- 2 Make sure that “Program Select” is selected.

If this is not selected, press “Program Select” to highlight it.

- 3 Use the VALUE controllers to select the program that you wish to play.

You can use the following methods to select a program.

- Turn the [VALUE] dial.
- Press the [△] or [▽] key.
- Use numeric keys [0]–[9] to specify the number, and press the [ENTER] key.

- 4 Audition the sound.

Play a note on the keyboard to hear the sound you selected.

Try operating various controllers to hear how the sound will change. (☞p.25)

Selecting the program bank

In Program mode, you can switch banks to select programs from another bank.

With the factory settings, banks INT-A–INT-D contain preloaded programs, and banks G, g(1)–G(9), and g(d) contain preset programs. (☞table below)

- 5 Press a PROG BANK [INT-A]–[EXB-G] key to select a bank.

The LED will light, and the selected bank will be displayed in the left of the LCD screen. For example to select bank INT-B, press the BANK [INT-B] key. (The [INT-B] key’s LED will light, and the upper left of the LCD screen will indicate Bank INT-B.)

Bank	Prog. No.	Explanation
INT-A...INT-D (I-A...I-D)	000...127	Preloaded programs (☞VNL)
INT-E (I-E)	000...127	User programs (e.g., programs that use samples you created)
INT-F (I-F)	000...127	EXB-MOSS programs
G	001...128	GM2 basic programs (☞VNL)
g(1)...(9)	(☞VNL)	GM2 variation programs
g(d)	(☞VNL)	GM2 drum programs
EXB-A...EXB-H (E-A...E-H)	000...127	User programs, EXB-PCM series programs

INT-A...INT-D

With the factory settings, these banks contain a wide variety of preloaded programs that use the internal PCM ROM multisamples, effects, and arpeggio patterns.

INT-E

This bank is used to store programs that you created, for example from samples that you created.

INT-F

This can be selected only if the EXB-MOSS option is installed. If the option is not installed, INT-F cannot be selected.

G, g(1)...g(9), g(d)

These banks contain 128 capital programs, 128 variation programs, and 9 drum programs, all compatible with the GM sound map. The programs of these banks are all read-only. These programs are preset programs. Each time you press the [G] key, the bank will change in the following order.

G→g(1)→g(2)→g(3)→g(4)→g(5)→g(6)→g(7)→g(8)→g(9)→g(d)→G...

(The LED will light, and the corresponding bank G, g(1)–g(9), g(d) will be displayed in the upper left of the LCD screen.)

EXB-A...EXB-G

With the factory settings, these banks do not contain programs. These banks are used to load programs for the EXB-PCM series options, or they can be used to hold programs that you create.

128 programs can be written or rewritten to each bank INT-A–INT-E, EXB-A–EXB-G (for a total of 1,536).

☞ For details of the program names etc., refer to “VNL” (Voice Name List).

Selecting programs by category

You can select programs by category such as keyboard, organ, bass, and drums.

With the factory settings, the preloaded programs and preset program are organized into sixteen categories. You can choose a category, and then select from the programs in that category.

① Press the Category popup button.

A tabbed “Category/Program Select” popup menu will appear.

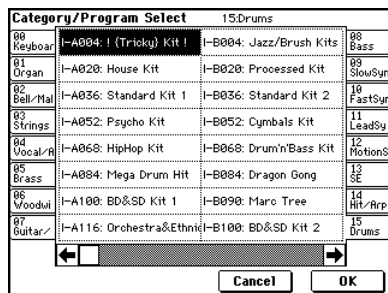

In the above graphic, category 15: Drums is selected. The center area shows the programs contained in that category.

② Press the tabs located at the left and right to select a different category.

The name of the selected category will be displayed in full in the upper right.

③ Press a program name in the center area to select a program.

The selected program will be highlighted.

note If you wish to change a program to be in a different category, you can choose the new category in the dialog box when writing the program (see p.56). Category names can be changed in “Category Name” (Global P4).

④ When you are satisfied with the selected program, press the OK button to close the popup menu.

If you press the **Cancel** button, the selection you made here will be discarded, and you will return to the program that had been selected before you opened the popup menu.

Selecting programs from the “Program Select” popup menu

You can select programs from a list organized by program bank.

① Press the “Program Select” popup button.

A tabbed “Bank/Program Select” popup menu will appear.

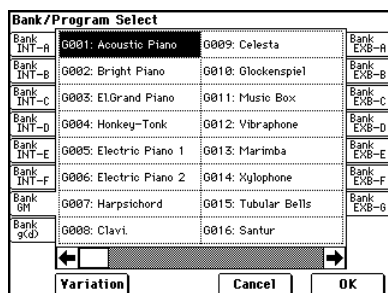

In the graphic, bank G is selected. The center area shows the programs contained in that bank.

note The **Variation** button will be displayed only when bank G is selected. Each time you press this button, the bank will change in the order of G→g(1)→g(2)...g(8)→g(9)→G...

② Press the tabs located at the left and right to select banks.

③ Press program names in the center area to select programs.

The selected program will be highlighted.

④ When you are satisfied with the selected program, press the OK button to close the popup menu.

If you press the **Cancel** button, the selection you made here will be discarded, and you will return to the program that had been selected before you opened the popup menu.

Using 10's HOLD to select programs

If you press the [./10's HOLD] key to turn on the 10's Hold function (the LCD screen will indicate 10^2 Hold), the ten's place of the program number will be fixed, and you will be able to switch programs simply by pressing a single numeric key. Each time you press a numeric key, the one's place will change. You can also use the [Δ][▽] keys to change the value of the ten's place.

① Press the [./10's HOLD] key to make the display indicate 10^2 Hold.

The ten's place of the program number will be held (fixed).

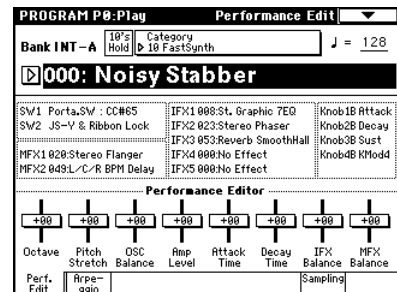

② By pressing a numeric key [0]–[9], you can input the one's place in a single action.

③ You can use the [Δ][▽] keys to change the value of ten's place.

④ To cancel the 10's HOLD function, press [./10's HOLD] to erase the 10^2 Hold display.

Using a connected switch to select programs

An optional on/off-type switch (such as the Korg PS-1) can be connected to the rear panel ASSIGNABLE SWITCH jack, and assigned a program select function. (see p.125)

Selecting programs from a MIDI device

MIDI program change messages can be transmitted from an external MIDI device, and received by TRITON STUDIO to select programs. (see PG p.260)

Selecting and playing a combination

In Combination mode you can select and play a combination from banks INT-A–EXB-G.

Try selecting various combinations and hear how they sound.

Selecting a combination

- 1 Press the [COMBI] key (the LED will light).

You will enter Combination mode. Make sure that the upper line of the LCD screen indicates “COMBINATION P0: Play.”

If this is not selected, press the [EXIT] key.



Selecting a combination number

- 2 Make sure that “Combination Select” is selected.
If this is not selected, press “Combination Select” to highlight it.
- 3 Use the VALUE controllers to select the combination that you wish to play.
“Selecting a program” [p.22](#) ③
- 4 Audition the sound.
Play a note on the keyboard to hear the sound you selected.
Try operating the various controllers and listen to how the sound changes. ([p.25](#))

Selecting the combination bank

In Combination mode, you can switch banks to select combinations from another bank.

With the factory settings, banks INT-A–INT-D contain combinations. ([table below](#))

- 5 Press a COMBI BANK [INT-A]–[EXB-G] key to select a bank.
The LED will light, and the selected bank will be displayed in the left of the LCD screen. For example to select bank INT-C, press the BANK [INT-C] key. (The [INT-C] key will light, and the upper left of the LCD screen will indicate Bank INT-C.)

Bank	Prog. No.	Explanation
INT-A...INT-D (I-A...I-D)	000...127	Preloaded combinations
INT-E (I-E)	000...127	User combinations, EXB-MOSS combinations
EXB-A...EXB-G	000...127	User combinations, EXB-PCM series combinations

INT-A...INT-D

With the factory settings, these banks contain a wide variety of preloaded combinations that use multiple programs, effects, and arpeggio patterns.

INT-E

With the factory settings, this bank does not contain combinations. This bank can be used to load combinations that use programs of the EXB-MOSS option, or to store combinations that you created.

EXB-A...EXB-G

With the factory settings, these banks do not contain combinations. These banks can be used to load combinations that use programs of the EXB-PCM option boards, or to store combinations that you have created.

128 programs can be written or rewritten to each bank INT-A–INT-E, EXB-A–EXB-G (for a total of 1,536).

For details of the combination names etc., refer to “VNL” (Voice Name List).

Selecting combinations by category

You can select combinations from any of the sixteen categories in the same way as for programs.

With the factory settings, all the preloaded combinations are organized into sixteen categories. You can choose a category, and then select from the combinations in that category.

“Selecting programs by category” [p.23](#)

Using 10’s HOLD to select combinations

You can fix the ten’s place of the combination number, so that a combination can be selected simply by pressing a numeric key once to change the one’s place.

“Using 10’s HOLD to select programs” [p.23](#)

Using a connected switch to select combinations

An optional on/off type foot switch such as the Korg PS-1 can be connected to the rear panel ASSIGNABLE SWITCH jack, and used to select combinations. ([p.125](#))

Selecting combinations from a MIDI device

MIDI program change messages can be transmitted from an external MIDI device, and received by TRITON STUDIO to select combinations. ([PG p.260](#))

Using controllers to modify the sound

The TRITON STUDIO provides various controllers – a joystick, the ribbon controller, the SW1 and SW2 switches, and the REALTIME CONTROL [1], [2], [3], [4] knobs – that let you modify the tone, pitch, volume, or effects in realtime while you play.

Each time you select a program or combination, try out these controllers to hear how they affect the sound.

note Tonal changes etc. produced by these controllers can be recorded on the internal sequencer or on an external MIDI sequencer.

Joystick

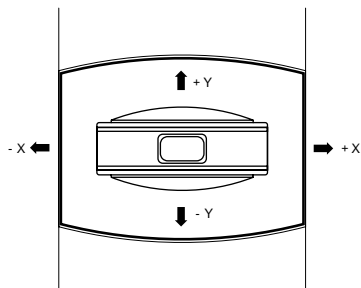

JS(+X): Move the joystick toward the right to apply an effect. Normally this is used to control the pitch (bend up).

JS(-X): Move the joystick toward the left to apply an effect. Normally this is used to control the pitch (bend down).

JS(+Y): Move the joystick away from yourself to apply an effect. Normally this is used to control the oscillator LFO (vibrato).

JS(-Y): Move the joystick toward yourself to apply an effect. Normally this is used to control filter LFO (wah).

note You can use the Lock function of [SW1] or [SW2] keys to hold the effect in the current position of the joystick. For the procedure, refer to “The lock function” on the following page.

note You can use the joystick as a source for alternate modulation or effect dynamic modulation, to control program parameters or effect parameters.

Ribbon controller

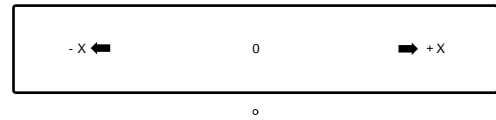

Move your finger to the left and right on the ribbon controller to apply an effect.

Normally, this is used to control pitch, volume or filter etc.

note You can use the Lock function of [SW1] or [SW2] keys to hold the effect even after you release your finger from the ribbon controller. For the procedure, refer to “The Lock function” on the following page.

note You can use the ribbon controller as a source for alternate modulation or effect dynamic modulation, to control program parameters or effect parameters.

SW1, SW2

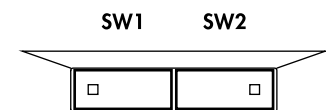

You can use these keys as sources for alternate modulation or effect dynamic modulation to control program parameters or effect parameters.

These switches can also be used to switch the octave, to turn portamento on/off, or to lock the position of the ribbon controller or after touch **lock function** (p.26).

You can specify the way in which the [SW1] and [SW2] keys will operate: either **Toggle**, when the assigned function will be switched between on and off each time the key is pressed, or **Momentary**, when the assigned function will be active on only as long as you hold down the switch.

note In Program mode, the function of the [SW1] and [SW2] keys can be checked in the P0: Play, Performance Edit page. (p.27)

note When you write a program or combination, the on/off status of the [SW1] and [SW2] keys is saved.

note For details on making these settings, refer to “Setting the function of [SW1] and [SW2]” (p.145).

The Lock function

Joystick

- 1 Select program bank INT-A001: Acoustic Piano, and play the keyboard.

To select a program, make sure that you are in Program mode, and press the BANK [INT-A] key, numeric key [1], and then the [ENTER] key.

- 2 Move the joystick toward yourself (the -Y direction).

The modulation will deepen, and at the same time, resonance will be applied to give a unique character to the sound.

- 3 While holding the joystick toward yourself, press the [SW2] switch (The [SW2] key LED will light).

The modulation effect at this point will be maintained. (Lock function)

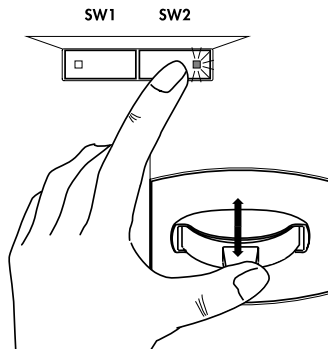

- 4 Release the joystick, and play the keyboard.

The modulation will stay the same as it was when the [SW2] key was pressed. Moving the joystick toward yourself will not affect the sound.

- 5 Press the [SW2] key once again to release the Lock function.

Ribbon controller

Make sure that the INT-A001: Acoustic Piano program is selected.

- 1 Press the [SW2] key. (The [SW2] key LED will light.)
- 2 Touch the ribbon controller, and move your finger to left and right.

Movement in the +X direction will brighten the tone, and movement in the -X direction will darken the tone.

- 3 Take your finger away from the ribbon controller.

The sound will remain as it was before you removed your finger. (Lock function)

- 4 Press the [SW2] key once again to release the Lock function.

note In the LCD screen, SW2 indicates JS-Y & Ribbon Lock. This means that the [SW2] key is assigned to control the Lock function for the joystick -Y direction and the ribbon controller (see PG p.249). The key will operate in Toggle mode.

If you move the joystick in the -Y direction, press the [SW2] key to turn on the Lock function, then operate the ribbon controller, and finally release both controllers, the sound you modified by the two controllers will be maintained.

note In many programs and combinations, the [SW2] key is assigned to control the Lock function for the joystick -Y direction and the ribbon controller.

note The Lock function can also be applied to aftertouch. If the [SW1] or [SW2] switch is assigned to After Touch Lock, the effect produced by pressing down on the keyboard can be held by turning on the [SW1] or [SW2] switch. For details on the [SW1] and [SW2] switch functions, refer to PG p.249.

REALTIME CONTROLS [1], [2], [3], [4]

These knobs can be used to control the filter cutoff frequency and resonance, the amp and filter EG, volume, portamento time, pan, pitch LFO, or the send levels to the master effects, etc.

- 1 Press the [REALTIME CONTROLS] key to switch the function of the realtime controllers to A-mode or B-mode.

Each time you press the key, A-mode or B-mode will be alternately selected, and the corresponding LED will light.

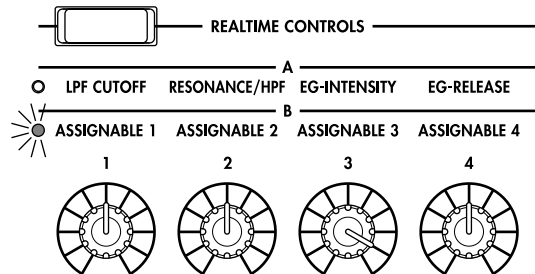

- 2 Rotate the desired knob to control the sound, etc.

A-mode controls

In A-mode, knobs [1]-[4] will control/edit the following functions.

note Placing the knobs in the center (12 o'clock) position will produce the values specified by the program parameters.

Knob [1]: LPF CUTOFF

Adjusts the cutoff frequency of the low pass filter. When you adjust the cutoff frequency of the filter, the brightness of the sound will change. The effect will depend on the settings of the program parameters, but normally, rotating the knob toward the left will darken the sound, and rotating it toward the right will brighten it.

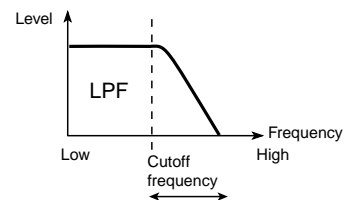

Knob [2]: RESONANCE/HPF

Adjust the resonance level of a low pass filter or the cutoff frequency of a high pass filter.

The content that is controlled will depend on the filter type specified by the program.

By adjusting the filter resonance level, you can increase or decrease the resonance level to add a unique character to the sound.

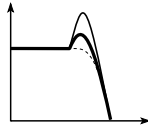

Adjusting the cutoff frequency of the high-pass filter will modify the fullness of the sound from which the low frequency range has been filtered out.

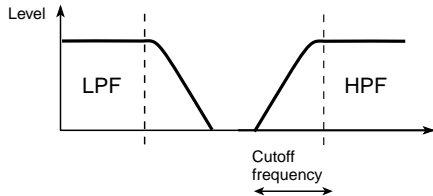

Knob [3]: EG-INTENSITY

Adjust the filter EG intensity (the depth at which the filter EG is applied).

Rotating the knob will affect the depth of the filter EG. Normally, rotating the knob toward the left will make the filter EG apply less deeply, and rotating it toward the right will make the filter EG apply more deeply. Since the filter EG will operate based on the cutoff frequency of the filter, knobs [1] and [3] will work together to control the tonal changes produced by the filter.

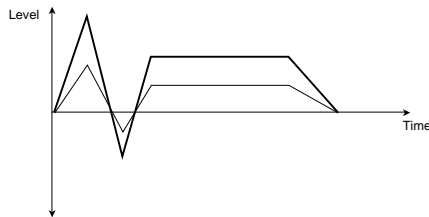

Knob [4]: EG-RELEASE

Adjusts the release times of the filter EG and the amp EG. This will determine the amount of time from note-off until the sound disappears.

When you adjust the knob, the release times of the filter EG and the amp EG will change. Normally, rotating the knob toward the left will shorten the release time, and rotating it toward the right will lengthen the release time.

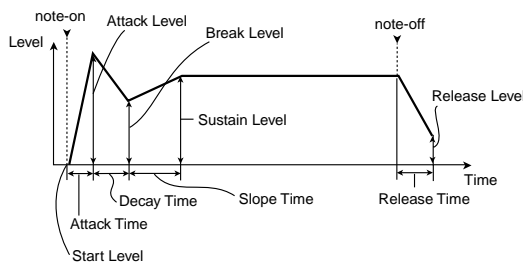

B-mode controls

Using these knobs, you can control parameters such as volume, portamento time, pan or filter and amp EG, pitch LFO, and master effect send levels etc.

The B-mode function settings are made for each individual program, combination, or song.

In Sampling mode and Song Play mode, the B-mode functions are set for the entire mode (Ⓜ p.145).

Viewing the parameters that are assigned to [SW1], [SW2] keys, and the REALTIME CONTROLS B-mode

In Program mode, the B-mode functions of the REALTIME CONTROLS knobs [1], [2], [3], and [4] and [SW1]/[SW2] keys can be verified in the P0: Play, Performance Edit page.

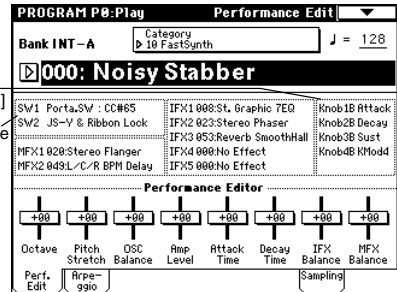

Functions assigned to the B-mode knobs [1]-[4]
 Functions assigned to the [SW1] and [SW2] keys

[VALUE] slider

When a program number is selected in Program P0: Play page, or when a combination number is selected in Combination mode page P0: Play page, you can use the [VALUE] slider as a source for alternate modulation or effect dynamic modulation, and control program parameters or effect parameters.

Keyboard

Velocity

The force with which you initially strike a note can apply an effect.

Normally this is used to control volume, or the speed or sensitivity of the EG.

After Touch

This effect can be applied by varying the pressure on a key that is already being held down.

Normally this is used to control volume, tone (cutoff frequency), or LFO sensitivity etc.

Note Number

Varying amounts of an effect will be applied depending on the position of the key on the keyboard.

Normally this is used to control volume, tone (cutoff frequency), LFO sensitivity, and EG sensitivity etc.

note This can be used as a source for alternate modulation or effect dynamic modulation, to control program parameters or effect parameters.

Foot pedals/Switch

Damper Pedal

An optional switch-type damper pedal such as the Korg DS-1H can be connected to TRITON STUDIO. If a DS-1H is connected, it will function as a half-damper pedal. The half-damper function cannot be controlled by other pedals.

Assignable Foot Switch

If an optional foot switch such as the Korg PS-1 is connected to the rear panel ASSIGNABLE SWITCH jack, an assigned function can be switched on/off using the foot switch.

The function of the foot switch is assigned in Global P2: Controller "Foot SW Assign" (p.125).

Assignable Foot Pedal

An optional expression pedal such as the Korg EXP-2 foot controller or Korg XVP-10 EXP/VOL pedal can be connected to the rear panel ASSIGNABLE PEDAL jack, and used to apply an effect.

The function of the foot pedal is assigned in Global P2: Controller "Foot Pedal Assign" (p.125).

ARPEGGIATOR [TEMPO] knob, [GATE] knob, [VELOCITY] knob

These knobs control the arpeggiator in realtime. For details on operation, refer to the following page.

Using the arpeggiator while you play

The arpeggiator is a function that automatically generates arpeggios (broken chords). Most arpeggiators produce an arpeggio when you play a chord on the keyboard.



The chord you played on the keyboard is sounded as an arpeggio (broken chord)

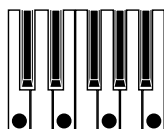

In addition to this, the TRITON STUDIO's arpeggiator is a polyphonic arpeggiator that is able to produce a variety of chordal transformations or phrases based on the pitch or timing of the notes you play on the keyboard. These functions let you use the arpeggiator to play a wide range of patterns including drum or bass phrases, and guitar or keyboard backing riffs. It is also effective to use the arpeggiator as part of the sound-creating process when creating subtly-moving pads, synth-sounds, or sound effects.

The TRITON STUDIO features a Dual Arpeggiator that lets you simultaneously use two arpeggio patterns in Combination mode, Sequencer mode, and Song Play mode. You can take advantage of this in many ways, such as applying separate arpeggio patterns to a drums program and a bass program, or using a keyboard split or velocity to switch between two arpeggio patterns.

The TRITON STUDIO provides five preset arpeggio patterns (the standard UP, DOWN, ALT1, ALT2, and RANDOM), and lets you program and store 507 user arpeggio patterns. With the factory settings, these contain a wide variety of preloaded user arpeggio patterns (see VNL). An arpeggio pattern that you create can also be stored as a user arpeggio pattern (see p.134).

Using the arpeggiator in Program mode

- 1 Press the [PROG] key to enter Program mode, and select a program. ("Selecting and playing a program" see p.22)

As you select various programs, you will notice that the ARPEGGIATOR [ON/OFF] key LED will light for some programs. ("Linking the arpeggiator to program combinations" see p.32) When you press the keyboard, the arpeggiator will start.

For other programs, you can press the ARPEGGIATOR [ON/OFF] key (the LED will light) to turn on the arpeggiator. Arpeggios will begin sounding when you play the keyboard.

- 2 As described in the following sections "Settings using controllers" and "Settings in the LCD screen," move the controllers or modify the parameters to change the way in which the arpeggios are played.

Settings using controllers

Arpeggiator on/off

- Each time you press the ARPEGGIATOR [ON/OFF] key, the arpeggiator will be switched on/off.

When the arpeggiator is turned on (the LED will light) and the selected arpeggio pattern will begin sounding when you play the keyboard.

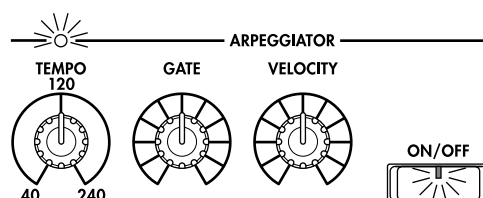

note The on/off status is saved when you write each program.

note In Combination, Song, and Song Play mode, depending on the arpeggiator A, B settings, the arpeggio may not start when you press the ARPEGGIATOR [ON/OFF] key to turn it on (see p.31).

Adjusting the arpeggiator tempo

- Rotate the ARPEGGIATOR [TEMPO] knob to adjust the tempo.

The "♩=" display in the upper right of the LCD will change. The tempo can be adjusted over a range of 40-240. You can also set the tempo by selecting "♩=" using numeric keys [0]-[9] to enter a tempo, and pressing the [ENTER] key. The tempo can also be set by the [VALUE] slider, [VALUE] dial, or [△][▽] keys. The LED will blink in time with the specified tempo.

note The knob setting is saved when you write each program.

note The arpeggio playback speed is affected by the “Reso” setting (Program P0: Play, Arpeggio page), or “Resolution” (P7: Edit-Arpeggiator, Arpeg. Setup page).

▲ If “MIDI Clock” (Global P1: MIDI) is set to **External MIDI** or **External mLAN**, the display will indicate “J=” **EXT**. The tempo will be synchronized to an external MIDI device, and it will not be possible to adjust the tempo on the TRITON STUDIO.

Adjusting the length of the arpeggiated notes

- **Rotate the ARPEGGIATOR [GATE] knob to adjust the length of the arpeggiated notes.**

Rotating the knob toward the left will shorten the duration of the notes, and rotating it toward the right will lengthen the duration of the notes. At the center position (12 o'clock), the note length will be as specified by the program parameter “Gate” (Program P7: Edit-Arpeggiator, Arpeg. Setup page).

note The knob setting is saved when you write each program.

note It is effective to control this function in conjunction with the REALTIME CONTROLS A-mode knob [4] (EG RELEASE).

Adjusting the strength of the arpeggio notes

- **Rotate the ARPEGGIATOR [VELOCITY] knob to adjust the strength of the arpeggio notes.**

Rotating the knob toward the left will make the notes softer, and rotating the knob toward the right will make the notes stronger. At the center position (12 o'clock), the velocity will be as specified by the program parameter “Velocity” (Program P7: Edit-Arpeggiator, Arpeg. Setup page).

note The knob setting is saved when you write each program.

note It is effective to control this function in conjunction with the REALTIME CONTROLS A-mode knobs [1] (LPF CUTOFF), [2] (RESONANCE/HPF), and [3] (EG- INTENSITY).

Settings in the LCD screen

- **In Program P0: Play, press the Arpeggio tab.**

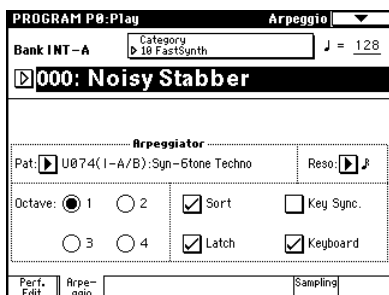

Selecting an arpeggio pattern

An arpeggio pattern can be selected from preset arpeggio patterns **P000–P004** and user arpeggio patterns **U000(I-A/B)–U506(User)**. With the factory settings, U000(I-A/B)–U199(I-A/B), U312(User)–U506(User) contain a wide variety of preloaded user arpeggio patterns. For the arpeggio pattern names (≡VNL).

- **Choose “Pat (Pattern Select),” and use the [VALUE] slider, [VALUE] dial, [Δ][▽] keys, and popup menu to select an arpeggio pattern.**

User arpeggio patterns can also be selected by using the numeric keys [0]–[9] to input the pattern number and then pressing the [ENTER] key. (≡p.130)

Changing the note value of the arpeggiated notes

The “Reso (Resolution)” parameter in the LCD screen lets you set the note value of the arpeggiated notes, over a range from ♩_3 – ♩ .

- **Press “Reso,” and use the [VALUE] slider, [VALUE] dial, [Δ][▽] keys, or popup menu to select the desired arpeggio note interval.**

Selecting the octave range in which the arpeggio is sounded

Use the “Octave” radio buttons in the LCD screen to specify the range of octaves in which the arpeggio will be sounded (≡p.131).

- **Press an “Octave” radio button to make your selection.**

Sounding an arpeggio in the order of the pitches in the chord you played

You can select whether the notes of the arpeggio will be sounded in the order of the pitches in the chord you played (regardless of the order in which you actually played the notes), or in the order in which you played the notes.

- **Press the “Sort” check box in the LCD screen to make this setting.**

Checked: the arpeggio will sound each note in the order of its pitch, regardless of the order in which you actually played the notes.

Unchecked: the arpeggio will sound each note in the order in which you actually played the notes.

Setting the arpeggio to continue playing even after you have taken your hand off the keyboard

You can select whether the arpeggio will continue playing when you take your hand off the keyboard, or whether the arpeggio will stop.

- **Press the “Latch” check box in the LCD screen to make this setting.**

Checked: The arpeggio will continue playing even after you remove your hand from the keyboard.

Unchecked: The arpeggio will stop playing when you remove your hand from the keyboard.

Synchronizing the arpeggiator to your keyboard timing

You can specify whether the arpeggio will begin at the moment you play the keyboard, or whether it will always play in synchronization to the MIDI clock tempo.

- Press the “Key Sync.” check box in the LCD screen to make this setting.

Checked: When you take your hand completely off of the keyboard and then play the first note-on, the arpeggio pattern will start from the beginning. This setting is suitable when you want the arpeggio to start from the beginning of the measure as you are playing in real-time.

Unchecked: The arpeggio will always be synchronized to the MIDI clock tempo.

Sounding both the arpeggio notes and the notes you play

- Press the “Keyboard” check box to make this setting.

Checked: The notes you play on the keyboard and the notes played by the arpeggiator will both sound.

Unchecked: Only the arpeggiated notes will sound.

Using the arpeggiator in Combination mode

In Combination mode the TRITON STUDIO provides dual arpeggiators, allowing you to run two arpeggio patterns simultaneously.

- ① Press the [COMBI] key to enter Combination mode, and select a combination. (“Selecting and playing a combination” [p.24](#))

As you select various combinations, you will notice that the ARPEGGIATOR [ON/OFF] key LED will light for some combinations. (“Linking the arpeggiator to program, combinations” [p.32](#)) When you press the keyboard, the arpeggiator will start.

For other combinations, you can press the ARPEGGIATOR [ON/OFF] key (the LED will light) to turn on the arpeggiator.

- ② As described in the preceding section “Settings using controllers” and the following section “Settings in the LCD screen,” move the controllers or modify the parameters to change the way in which the arpeggios are played.

 The ARPEGGIATOR [ON/OFF] key, ARPEGGIATOR [TEMPO] knob, ARPEGGIATOR [GATE] knob, and ARPEGGIATOR [VELOCITY] knob will apply to both arpeggiators A and B. Their state is saved when the combination is written.

Settings in the LCD screen

- In Combination P0: Play, press the Arpegg. A tab.



Select the arpeggiator(s) that will run

Use the “Arpeggiator Run” check boxes to specify the arpeggiator(s) that you want to have running. The arpeggiator(s) that are checked here will operate when the ARPEGGIATOR [ON/OFF] key is on. However, the arpeggiator will play a timbre only if the table displayed next to the check boxes assigns arpeggiator A or B to a T (timbre) 1–8. These settings are made in Combination P7: Edit-Arp., Setup page “Arpeggiator Assign” ([p.132](#)).

Arpeggiator-A, Arpeggiator-B

For each arpeggiator A and B, you can make settings for “Pat (Pattern Select),” “Reso (Resolution),” “Octave,” “Sort,” “Latch,” “Key Sync,” and “Keyboard.” ([p.130](#))

Checking the structure of a user arpeggio pattern

Let's see how combination INT-B097: Try Some Tekno is constructed.

- Select combination INT-B097: Try Some Tekno, and look at the Arpeggio Play A page and Arpeggio Play B page.

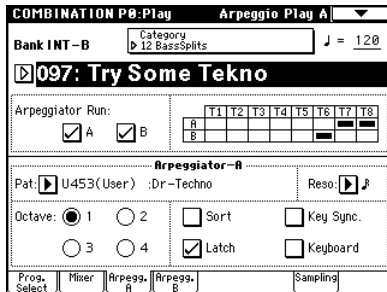

- As you can see from the “Timbre Assign” table, arpeggiator A is assigned to timbre 7 and 8, and arpeggiator B is assigned to timbre 6. When you play the keyboard the U453 (User): Dr-Techno arpeggio pattern will play the program INT-C004: Trance/GrageKit of timbre 7 (Timbre 8 is a dummy timbre used to operate Timbre 7. p.133). The P000: UP arpeggio pattern will play the program INT-C122: Synchro Science of timbre 6.
- If you uncheck “Arpeggiator Run A” or “Arpeggiator Run B,” the unchecked arpeggiator will stop. If you check it once again and play the keyboard, the arpeggiator will begin running.
- Look at the Combination P7: Edit-Arp., Scan Zone A/B page, and you will see that the A keys “Top Key” and “Bottom Key” are set so that arpeggiator A will operate only for keys B3 and lower, and that the B “Top Key” and “Bottom Key” are set so that arpeggiator B will operate only for keys C4 and higher.

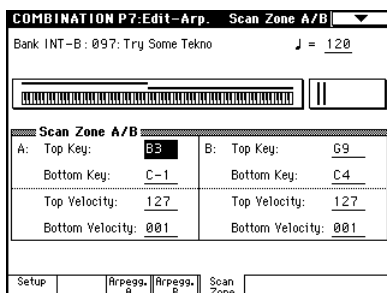

Other settings for the arpeggiator

You can also set “Gate,” “Velocity,” “Swing,” and “Scan Zone.” These parameters are set in Program P7: Edit-Arpeggiator, Arpeg. Setup Page, Combination P7: Edit-Arp., Arpeggiator A, B page. (p.131).

Linking the arpeggiator to program, combinations

You can specify whether the arpeggiator settings written in a program or combination will also be selected when you switch programs or combinations, or whether the arpeggiator status will not change when you switch programs or combinations.

With the factory settings, the former is selected. Use the latter when you want to keep the same arpeggio pattern running, and change only the program sound.

This setting is made in “Auto Arpeggiator” (Global P0: Basic Setup, Basic page).

Creating a user arpeggio pattern

Arpeggio patterns that you create can be written to U000 (I-A/B)–U506 (User).

These can be created in Global P6: User Arpeggio (p.134).

Playing with the RPPR (Realtime Pattern Play/Recording) function

TRITON STUDIO's Sequencer mode provides an **RPPR (Realtime Pattern Play/Recording)** function.

Using the **RPPR function**, each note of the keyboard can be assigned to a preset pattern or user pattern and a track that will play the assigned pattern. You can then playback the assigned pattern in realtime (and record it, if desired) simply by playing the corresponding note. (Preset patterns suitable for playing by the drum track are already provided in the internal memory.)

Here we will explain how to use the RPPR function to play a demo song.

- ① **Load the demo song data as described in "1. Loading the demo song data in Disk mode" (p.20).**
- ② **Press the [SEQ] key (the LED will light) to enter Sequencer mode, and access the P0: Play/REC, Program T01-08 page.**
- ③ **In "Song Select," select S005: Midnight Sun.**
Select the song as described in "2. Selecting and playing a demonstration song in Sequencer mode" (p.21).



- ④ **Make sure that the "RPPR" check box is checked.**
Checked: The specified RPPR (set in Sequencer P6: Pattern/RPPR, RPPR Setup) will function.
Unchecked: RPPR will not function. Operation will be as in normal Sequencer mode.
- ⑤ **Press a key.**
 The pattern assigned to that key will playback. In some cases, the pattern will continue playing after you release your hand from the keyboard. You can stop playback either by pressing that key again, or by pressing a key in the area of C2 or below.

Shutdown Keys:

When you play a key in the range of C-1 – C2, the currently-playing pattern will stop.

Pattern Assignable:

A pattern and track can be assigned to each of the 72 keys in the range of C#2–C8. If you do not assign a key, it can be used to play as usual.

As in the example shown in the following diagram, you can make one key play a drums pattern, another key a bass phrase, and yet another key play guitar chords, all by specifying a different pattern and track for each key.

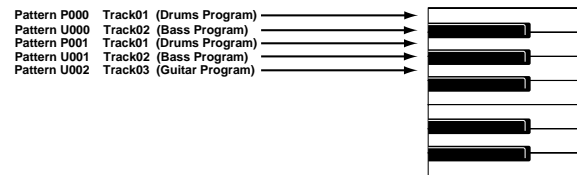
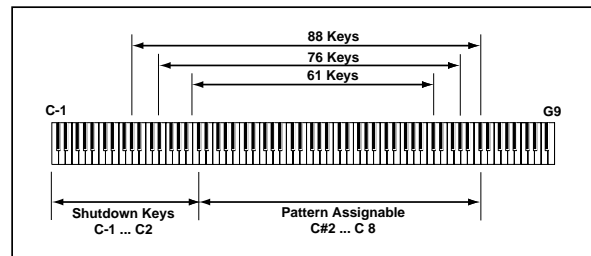

Simple program editing

By operating the performance editor and the realtime controllers you can easily and intuitively modify the sound of a program.

Program editing refers to the process of modifying the parameters that make up a program, in order to modify the sound or change the controller, effect settings etc.

note More detailed editing can be performed in Program P1: Edit-Basic – P9: Edit-Master Effect.

Performance Edit

By using the eight sliders of the Performance Editor, you can make overall adjustments to the sound. When you edit the setting, multiple program parameters are adjusted simultaneously.

① Press the [PROG] key (the LED will light) to enter Program mode.

② Press the Perf. Edit tab.

The Performance Edit page will appear.

Functions assigned to [SW1] and [SW2] keys Type of Insert effect

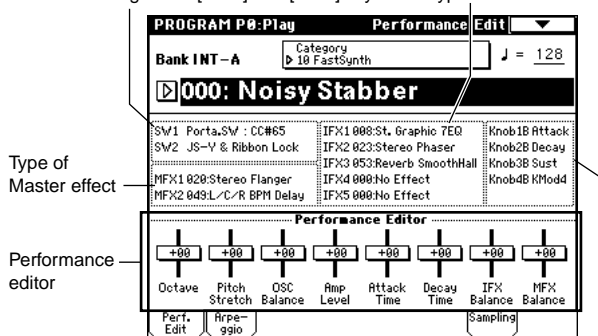

Parameters assigned to B-mode of the realtime editor

③ Select the Program.

④ Select the Performance Editor, and use the VALUE controllers to edit the settings.

note If you want to reset the value to the value saved with the selected program, press numeric key [0] and then press the [ENTER] key to restore the previous setting.

- **Octave:** Indicates the octave setting.
- **Pitch Stretch:** Simultaneously adjusts the transpose and tune settings of the oscillator. This allows you to produce a variety of tonal changes without losing the character of the original sound.

note This is particularly effective for acoustic-type programs such as guitar, bass, or piano. Select various programs and try this out.

⚠ “Pitch Stretch” cannot be used with bank INT-F.

- **OSC Balance:** Adjusts the level balance between oscillators 1 and 2.

⚠ For programs whose “Oscillator Mode” (Program P1: Edit-Basic, Program Basic page) setting is **Single**, oscillator 2 will not sound. Only the level of oscillator 1 will change. For a **Drums** program, this performance editor will have no effect.

- **Amp Level:** Indicates the amp level. This will adjust the volume of the entire program.
- **Attack Time:** Indicates the attack time of the filter EG and amp EG. This will adjust the speed of the attack from note-on.

⚠ In order to maximize the effect of the Attack Time adjustment, the amp EG Start Level, Attack Level, Start Level Modulation, and Attack Time Modulation parameters are also adjusted.

- **Decay Time:** Indicates the decay time and slope time of the filter EG and amp EG.
- **IFX Balance:** This simultaneously adjusts the “Wet/Dry” balance of all insert effect.
- **MFX Balance:** This simultaneously adjusts the Return 1 and 2 parameters of the master effects.

⚠ Depending on the settings of the program parameters, the result may not be noticeable.

Realtime controls

The REALTIME CONTROLS [1]–[4] knobs can be used to edit parameters such as the filter cutoff frequency, resonance, the amp and filter EG, release, volume, portamento time, pan, pitch LFO, and master effect send level etc. (p.26).

⚠ If CC#70–79 are assigned to REALTIME CONTROLS A-mode or B-mode, the sound edited by knobs [1]–[4] can be saved by the Program Write operation.

Writing a program

⚠ The edited content will be lost if you select another program or turn off the power before saving.

- If you want to save the modified sound, select the page menu command “Write Program,” and write the program. (p.56)

It is best to write your own edited programs into an initial (initialized) program of bank INT-E or EXB-A–EXB-G. You should also give a new name to the program you are writing.

note If you want to overwrite the program using the same program number, press the SEQUENCER [REC/WRITE] key and then press the OK button.

Simple combination editing

A combination is a set of multiple (up to eight) programs, and allows you to create complex sounds that could not be produced by a single program.

Combination editing refers to the process of modifying the sound of a combination by changing the program selected for each timbre or by adjusting each timbre's keyboard range and velocity range, or by modifying the controller, and effect settings.

You can edit a combination in Combination P1: Edit-Program/Mixer-P9: Edit-Master FX, but can also make settings for "Program Select," "Pan," and "Volume" in Combination P0: Play as well.

An example of editing

As an example, here's how to do some simple editing on combination Bank INT-C086: Shiny DigiPiano.

- 1 Press the [COMBI] key (the LED will light) to enter Combination mode.
- 2 Select INT-C086: Shiny DigiPiano.

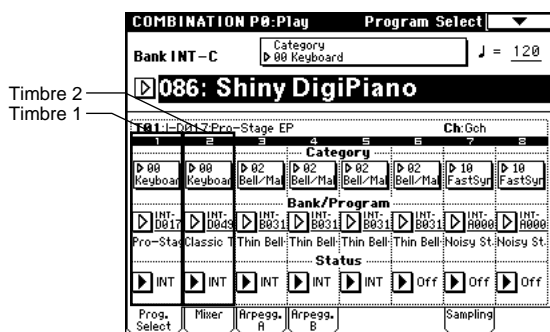

This combination layers (simultaneously sounds) the programs of timbre 1 and timbre 2. A typical electric piano INT-D017: Pro-Stage EP is assigned to Timbre 1, and a digital-type electric piano INT-D049: Classic Tines is assigned to Timbre 2. These two programs are layered to create a frequently-heard type of electric piano sound.

note A timbre consists of a program together with multiple parameters that control that program. A combination can use up to eight of these timbres.

Selecting the program for a timbre

- 3 Press the Prog. Select tab.

When a timbre's "Status" is turned Off, the program assigned to that timbre will not sound. If the "Status" is set to INT, the program will sound. Try setting timbres 1 and 2 alternately to INT and Off, and listen to the result.

Only timbre 1 will sound

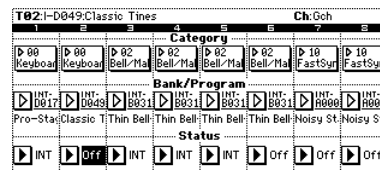

Only timbre 2 will sound

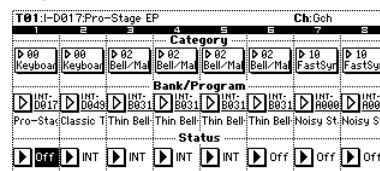

After you have listened to the sound, set the "Status" for timbres 1 and 2 to INT.

note As an alternative to changing the "Status" setting, you can select the page menu command "Solo Selected Timbre" to hear the sound of an individual timbre.

- 4 Now let's change the program of timbre 2 to a different program. Press the timbre 2 "Bank/Program (Program Select)" switch (it will be highlighted).

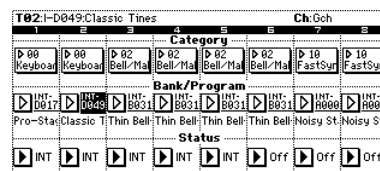

Use the BANK [INT-A]-[EXB-G] keys, and VALUE controllers to select a program.

Alternatively, you can select a program from a popup menu. Press the popup button, and select the desired program from the popup menu that appears.

- 5 You can also select programs by category. Press Category popup button for timbre 2.

The "Category/Timbre2 Program" select menu will appear. In this combination, a program from the "Keyboard" category is selected for both timbres 1 and 2.

- If you wish to select a different program from the same category, press the desired program. That program will be highlighted. Press the scroll bar to see other programs in the same category.

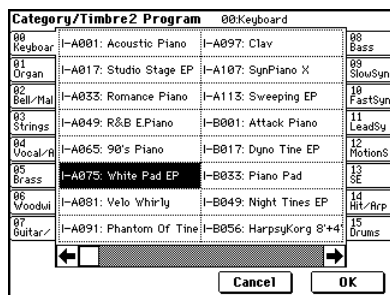

- If you wish to select a program from a different category, press one of the tabs located to the left and right to select the desired category. The full name of the selected category will appear in the upper right.

Let's select the 04: Vocal/Airy category. Press the **04 Vocal/Airy electric** tab, and then press the desired program to select it. The program you pressed will be highlighted. Press the scroll bar to see other programs in the same category. For this example, select **INT-C027: Dream Voices**. This will produce a layered combination consisting of a piano and voice.

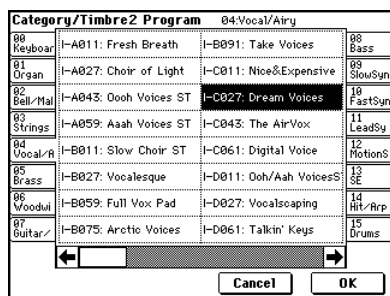

- ⑥ If you are satisfied with the selected program, press the OK button to close the popup menu.

If you press the **Cancel** button, your selection will be discarded, and you will return to the program that had been selected before the popup menu was opened. For this example, press the **OK** button.

Adjusting the stereo position

- ⑦ Press the Mixer tab.



- ⑧ Press "Pan" for timbre 2 (it will be highlighted), and use the VALUE controllers to edit the setting.

With a setting of **C064** the sound will be located in the center. A setting of **L001** places the sound at the far left, and **R127** at the far right. With a setting of **RND**, the sound will move randomly between left and right each time a note is played.

Adjusting the volume

- ⑨ Press "Volume" for timbre 2 (it will be highlighted), and use the VALUE controllers to edit the setting.

note If you check "Hold Balance" and adjust the "Volume" value, the volume balance between the timbres at the time that "Hold Balance" was checked will be maintained while the volume of all timbres is adjusted.

Writing a Combination

⚠ The edited content will be lost if you select another Combination or turn off the power before saving.

- If you want to save the modified sound, select the page menu command "Write Combination," and write the program. (p.56)

It is best to write your own edited Combinations into an initial (initialized) combination of bank INT-E or EXB-A-EXB-G. You should also give a new name to the combination you are writing.

note If you want to overwrite the combination using the same combination number, press the SEQUENCER [REC/WRITE] key and then press the **OK** button.

Sampling (recording a sample)

The TRITON STUDIO can record 48 kHz stereo 16-bit samples. Sampling can be performed in Sampling, Program, Combination, and Sequencer modes. (Open Sampling System)

The various functions of each mode can be used while sampling.

Here are some examples.

- Sample a vocal from a mic, and play it back using “one-shot” playback.
- Apply insert effects to the audio input, and sample the result.
- Name multisamples or samples.
- Save the data you sampled.
- Convert a multisample into a program.
- Sample and loop-playback a drum phrase, etc.
- In Program mode, resample a phrase played by the arpeggiator.
- In Program mode, listen to drum phrases played by the arpeggiator while you sample the external input from a guitar.

note The example procedures described here begin from the initial settings of the TRITON STUDIO immediately after power-on.

For other procedures and more detailed explanations, refer to p.99 or PG p.87.

Sampling a vocal from a mic, and playing it as a “one-shot” sample

1. Connect a mic and make input settings (Input)

- ① Connect a mic to the AUDIO INPUT 1 jack located on the rear panel.

Set the AUDIO INPUT [MIC/LINE] switch to the MIC position, and set the [LEVEL] knob to the center.

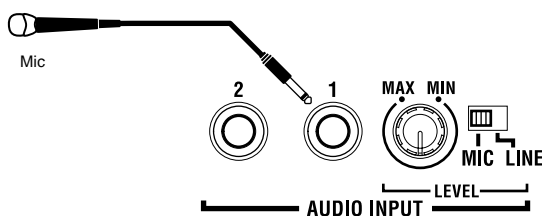

- ② Press the [SAMPLING] key to enter Sampling mode.

- ③ Press the Input Setup tab to select the P0: Recording, Input/Setup page.

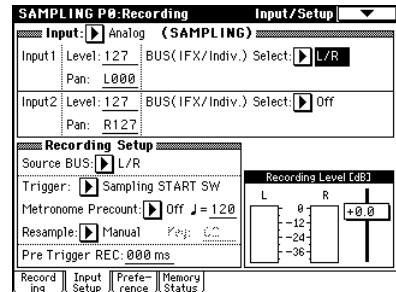

- ④ Set “Input” to Analog.
- ⑤ In the Input1 area, set “BUS” to L/R, specifying the bus to which the AUDIO INPUT 1 jack will be input. Make sure that the Input1 level (“Level”) is 127, and the “Pan” is L000.

! Be aware that when “BUS” is changed from Off to L/R or IFX1–5, the volume level to the AUDIO OUT L/MONO and R jacks or to the headphones may rise abruptly.

2. Set the recording level (Recording Level [dB])

- ① Speak into the mic at the volume that you will use for recording.

If the display indicates “ADC OVERLOAD !!” (AD converter input overload), turn the rear panel [LEVEL] knob toward MIN to adjust the level appropriately.

note The best audio quality will be obtained at the highest possible level that does not cause an overload; i.e., a level that is slightly below the point where “ADC OVERLOAD !!” is displayed.

- ② Press the SAMPLING [REC] key.

Speak into the mic at the volume that you will use for recording.

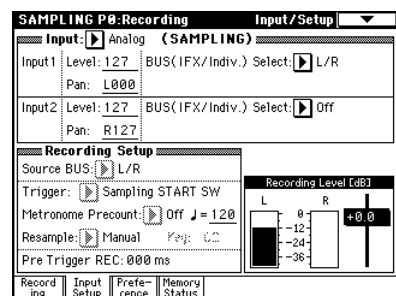

The level meter will show the input volume. If the display indicates “CLIP!,” use the VALUE controller to lower the “Recording Level” slider (located in the right of the display) from the +0.0 setting down to an appropriate level.

- ③ When you have finished making adjustments, press the SAMPLING [REC] key again.

3. Specify the recording method (Recording Setup)

- 1 Set "Source BUS" to L/R.

Now you can sample the sound of the L/R channels, which is output from the headphones and from AUDIO OUTPUT (MAIN) L/MONO and R.

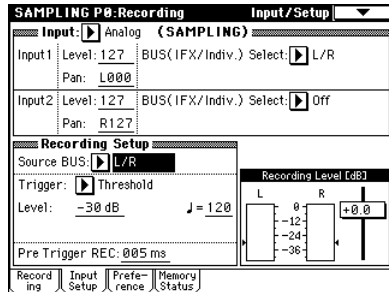

- 2 Set "Trigger" to Threshold, and set "Level" to -30.

With this setting, recording will begin automatically when the audio input reaches -30 dB or higher in record-ready mode.

- 3 Set "Pre Trigger" to 005 ms.

With this setting, sample recording will begin 5 ms earlier than (i.e., immediately before) sampling is actually triggered, so that the very beginning of the sound is not lost.

note In Sampling mode, the "Trigger" parameter which specifies how recording will begin can be set to various settings other than the **Threshold** setting used above. You can choose **Sampling START SW** so that recording will begin when you press the SAMPLING [START] key, or **Note On** so that recording will begin when you play the keyboard. (p.43, 45)

4. Settings for the sample that will be recorded (REC Sample Setup)

- 1 Press the Recording tab to access the P0: Recording, Recording page.

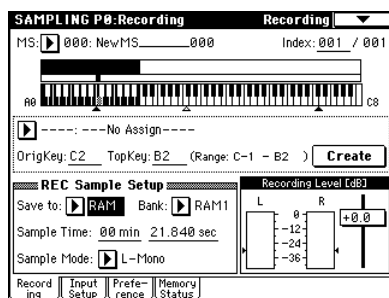

- 2 Set "Save to" to RAM.

The sample you record will be written into sample memory (RAM). (For details on the **DISK** setting, refer to p.105)

- 3 Set "Sampling Mode" to L-Mono.

With this setting, the internal L channel will be sampled in mono.

5. Create a multisample and indexes

- 1 In the upper left of the P0: Recording, Recording page, make sure that 000 is selected for "MS" (multi-sample).

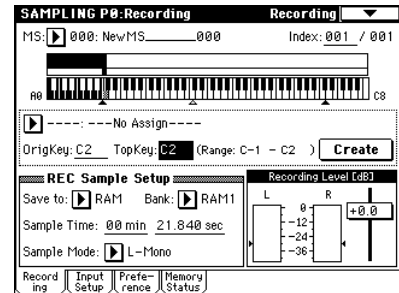

note When you want to create a new multisample, press the "MS (Multisample Select)" popup button, press a Multisample No. (or use the numeric keys to input a number) for which there is no name in the list, and then press the [ENTER] key. (p.106)

- 2 Set "OrigKey (Original Key)" and "TopKey" to C2.

When you play the key designated by "OrigKey," the sample will sound at the same pitch at which it was sampled.

note You can make this setting easily by holding down the [ENTER] key and pressing the C2 key. If you want to use the numeric keys to input this setting, press [3], [6], and [ENTER].

- 3 Press the Preference tab to access the P0: Recording, Preference page.

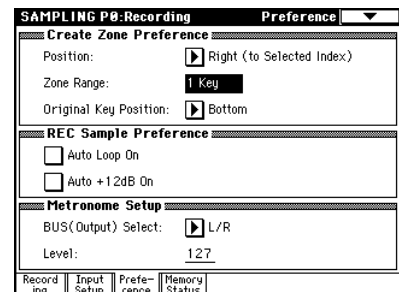

- 4 Set "Zone Range" to 1 Key.

When you create a new index, the width of the zone will be set to one key.

- 5 Press the "Auto Loop On" check box to uncheck it.

Looping will automatically be turned off for the sample that is recorded.

6. Record a sample

- 1 Press the Recording tab to access the P0: Recording, Recording page.

- 2 Press the SAMPLING [REC] key.

Press the SAMPLING [START/STOP] key to enter record-ready mode.

Speak the word that you want to sample. (Example: "It's")

Recording will start when the input exceeds the "Level" -30dB level.

When you finish speaking, press the SAMPLING [START/STOP] key to stop sampling.

A sample has now been created. The sample you recorded is automatically assigned to "Sample (Sample Select)."

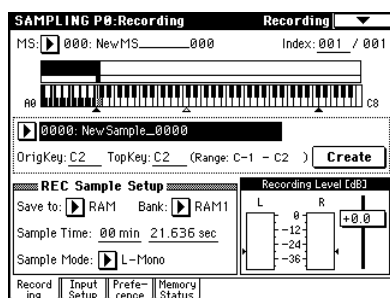

Press the "OrigKey" note (C2 in this case), and you will hear the sound that was sampled.

- 3 Press the Create button to create a new index.

- 4 Press the SAMPLING [REC] key.

Press the SAMPLING [START/STOP] key.

Speak the word that you want to sample. (Example: "So")

When you finish speaking, press the SAMPLING [START/STOP] key to stop sampling.

- 5 Repeat steps 3 and 4 to record additional samples.

(Example: "Easy," "To," "Sample," "With" "TRITON STUDIO")

- 6 Play consecutive notes on the keyboard.

Play a chromatic scale upward, starting at the C2 key. The samples you recorded will be played one after another.

(In this example, playing notes C2 through F#2 in sequence will produce "It's So Easy To Sample With TRITON STUDIO")

Applying an insert effect to the audio input and sampling the result

- 1 In step 5 of the preceding section "1. Connect a mic and make input settings," set the Input1 "Pan" to C064, and "BUS" to IFX1.

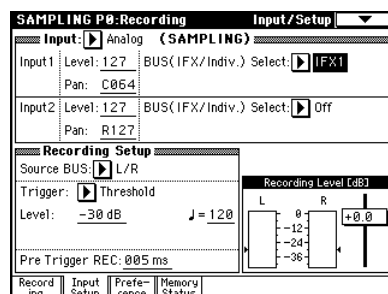

- 2 Press the [MENU] key to access the Jump page, and press P8: Insert Effect.

The P8: Insert Effect page will appear.

Press the Insert FX tab to access the Insert FX page.

- 3 Select "IFX1," use the numeric keys to enter [5], [2], and press the [ENTER] key to confirm 052: Reverb Hall.

Press "IFX1 On/Off" to turn it ON.

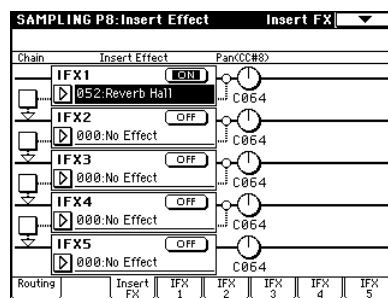

- 4 Speak into the mic, and verify that reverb is applied to the sound.

You can adjust the effect settings in the IFX1 page (IFX1 tab).

- 5 After pressing the [EXIT] key, press the Recording tab to access the P0: Recording, Recording page.

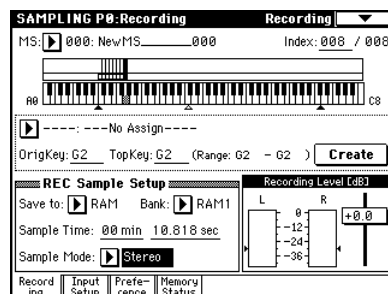

- 6 Set "Sample Mode" to Stereo.

Now the sound of the internal LR channels can be sampled in stereo.

- 7 Press the Create button to create a new index.

⑧ **Press the SAMPLING [REC] key.**

Press the SAMPLING [START/STOP] key, and speak the word(s) that you want to sample.

Speak the word that you want to sample. (Example: "It's")

Recording will start when the input exceeds the "Level" -30dB level.

Press the SAMPLING [START/STOP] key to stop.

⑨ **Play the keyboard.**

When you play the "OrigKey" note, you will hear the sound that was sampled.

Press the Clear button.

Press the **Shift** button to switch to uppercase letters, and press **S, M, P, L, -, and D** in that order.

Press the **Shift** button once again to switch to lowercase letters, and press **e, m, and o** in that order.

Press the **OK** button to close the text dialog box.

If you do not need to make any corrections, press the **OK** button to execute "Rename Multisample" and complete the procedure.

note A stereo multisample will have a -L and -R displayed at the end of the name, meaning that you will be able to input 14 characters. (The -L and -R are fixed.) You can input 16 characters for a mono multisample. This also applies to samples.

Assigning a name to the sample or multisample

The TRITON STUDIO allows you to create up to 4,000 samples and 1,000 multisamples (limited by the amount of memory). It is a good idea to assign names so that you can distinguish individual samples and multisamples.

Naming a multisample

- 1 Press the Recording tab to access the P0: Recording, Recording page.
- 2 In "MS," select the multisample that you want to name.
- 3 Press the page menu button to access the page menu, and press "Rename MS."

Delete Sample	MS Mono To Stereo
Copy Sample	Sample Mono To Stereo
Rename Sample	Keyboard Display
Delete MS	Move Sample
Copy MS	Move MS
Rename MS	Optimize RAM
Convert MS To Program	Select Directory

A dialog box will appear.

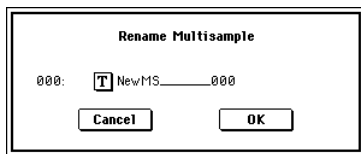

Press the text dialog button to display the text dialog box, and assign a name of SMPL-Demo (p.56).

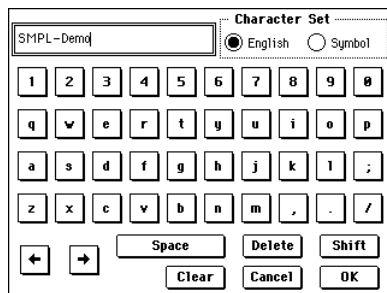

Naming a sample

- 1 Press the Recording tab to access the P0: Recording, Recording page.
- 2 Select "Index," and use the [△][▽] keys to select the sample to which you want to assign a name.

For this example, select "Index" 001.

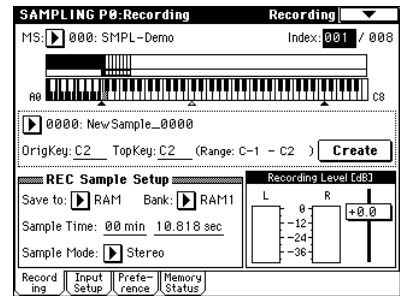

It is also possible to select a sample in "Sample (Sample Select)," but since the sample assigned to each index can change, you should use "Index" to select a sample.

- 3 Press the page menu button to access the page menu, and press "Rename Sample."
- When the dialog box appears, press the text edit button to access the text dialog box, and assign the desired sample name. (Example: "Its")
- Refer to step ③ of "Naming a multisample."
- 4 Select "Index," select the next sample that you want to name, and use the page menu command "Rename Sample" to assign a name to that sample.

Saving sample data

Here's how to save a sample or multisample that you created.

- ⚠ All samples and multisamples in the TRITON STUDIO will be lost when the power is turned off.

Sample data can be saved on a floppy disk, the internal hard drive, the CDRW-1 option, or external SCSI storage media (hard disk, MO, Zip, Jaz, ORB, CD-R/RW, etc.).

- ① Insert the media and/or make the appropriate settings for the connected external SCSI device so that it is ready to save data.
- ② Press the [DISK] key to select Disk mode.
- ③ Press the Save tab.

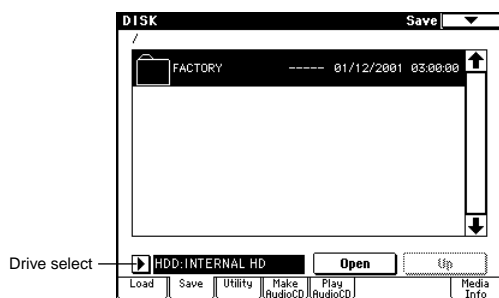

- ④ If you want to save to a different device, use the drive select setting to select the device on which you want to save the data.
- ⑤ Press the page menu button to access the page menu, and press "Save Sampling Data."



- ⑥ When the dialog box appears, press the text edit button to access the text dialog box, assign a filename of SMPL_DM1, and press the OK button.
- ⑦ Make sure that the All radio button is selected, and press the OK button to save the data.

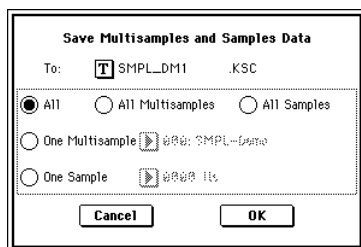

When saving is completed, a file with an extension of .KSC together with the .KMP and .KSF files (in folders) will be saved. For details on each file, refer to PG p.162 "About Korg format PCM data files."

Converting a multisample into a program

A multisample you create can be converted into a program. If a sample or multisample is converted into a program, it can be played in Program mode or used in Combination mode and Sequencer mode.

- ① Press the [SAMPLING] key to enter Sampling mode.
- ② Create a multisample.
Refer to "Sampling a vocal from a mic, and playing it as a "one-shot" sample" (p.37).
- ③ Press the [EXIT] key to select the P0: Recording page.
- ④ Press the page menu button to access the page menu, and press "Convert MS To Program."

The following dialog box will appear.

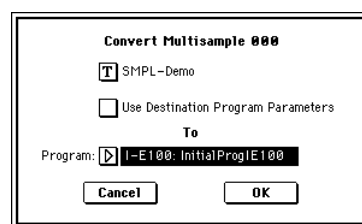

- ⑤ In the To "Program:" field, select the program into which the data will be converted.

We recommend that you select one of the initialized programs in bank I-E.

- ⚠ When you execute the Convert operation, the program in the conversion destination location will be overwritten and replaced by the converted program.

- ⑥ Set the "Use Destination Program Parameters" setting.

For this example, leave this unchecked. If you execute the conversion with this unchecked, the program will be created using the sound that you heard in Sampling mode.

- note** If you want to use the program parameters of a pre-loaded program (INT-A000-INT-D127), copy that program to bank INT-E before you perform this operation. Use the To "Program:" field to select that program, and check "Use Destination Program Parameters" before you perform the conversion. However if you want to convert a stereo multisample with "Use Destination Program Parameters" checked, you must change the "Oscillator Mode" (PG p.7) to **Double** for the conversion destination program (To "Program") before executing the conversion.

- ⑦ As necessary, press the text edit button to access the text dialog box and assign a program name.
- ⑧ Press the OK button. A dialog box will ask you for conformation. Press the OK button once again, and the conversion will begin.
- ⑨ Listen to the converted program.

Switch to Program mode, select the program (INT-E100 in the above example), and play the keyboard to hear the sound.

The converted program settings will automatically be stored in the internal memory, but the sample data you created will be lost when the power is turned off. In order to reproduce the sound of the program after the power is turned on again, you must first load the previously-saved sample data back into the TRITON STUDIO, using the Disk mode. When loading, it is best to set “.KSC Allocation” to Clear.

When saving, it is a good idea to execute “Save All” (PG p.166) to save the samples and multisamples along with the converted program, and then load all of this data together. (PG p.157, 162)

Sampling and looping a drum phrase

Here’s how you can sample a drum phrase (or similar phrase) from an audio CD, and loop the playback.

You will need to provide a drum rhythm loop sample. Initially, it is a good idea to begin with a rhythm loop sample that has a fairly simple beat.

As an example, we will sample one measure of a 140 BPM drum phrase in a 4/4 time signature. In this example we will use a CD player. For details on how you can digitally sample or “rip” from the CDRW-1 option or from a SCSI-connected CD-ROM or CD-R/RW, refer to p.108.

note This explanation assumes that you are starting from the default state immediately after power-on.

1. Connect your external audio device and adjust the input settings (Input)

- 1 Connect the AUDIO INPUT 1, 2 jacks on the rear panel to the LINE OUT L and R jacks of your CD player.

Set the AUDIO INPUT [MIC/LINE] switch to the LINE position, and set the [LEVEL] knob near the center.

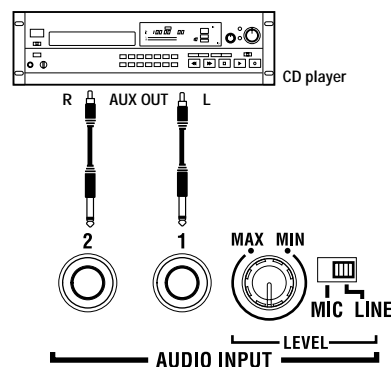

note If the CDRW-1 option is installed, the analog audio will be internally connected to the AUDIO INPUT 1 and 2 jacks.

You can also “rip” digital audio data via the CDRW-1 option or a SCSI-connected CD-R/RW. (p.108)

- 2 Press the [SAMPLING] key to enter Sampling mode.
- 3 Press the Input Setup tab to select the P0: Recording, Input/Setup page.

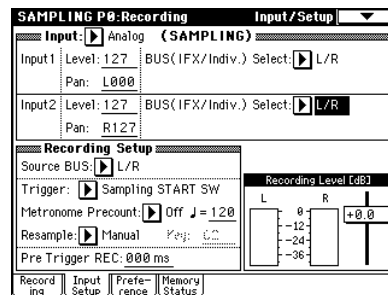

- 4 Set the various parameters so that the signal from the AUDIO INPUT jacks will be input to the TRITON STUDIO.

Set the following parameters as shown.

Input 1: "Level" 127, "Pan" L000, "BUS" L/R

Input 2: "Level" 127, "Pan" R127, "BUS" L/R

- ⚠** When you change the Bus setting from Off to L/R or IFX, the volume level of the AUDIO OUT L/MONO and R jacks or the headphone volume may rise abruptly. Please use caution.

2. Set the recording level (Recording Level [dB])

- ① **Play back the audio source that you want to record.**

If the display indicates "ADC OVERLOAD !!" (AD converter input overload!), lower the level by turning the rear panel [LEVEL] knob to an appropriate position. Alternatively, lower the level of the output source.

- note** The best audio quality will be obtained at a level slightly lower than when the "ADC OVERLOAD !!" indication appears (i.e., the highest level that does not cause an input overload).

- ② **Press the SAMPLING [REC] key.**

The level meter allows you to check the volume of the input.

If the display indicates "CLIP!!," use the VALUE controller to lower the "Recording Level" slider (located in the right of the display) from the +0.0 position to an appropriate level.

- ③ **When you have finished making adjustments, once again press the SAMPLING [REC] key. Also stop the playback of your audio source.**

3. Specify the recording method (Recording)

- ① **Set "Source BUS" to L/R.**

This setting lets you sample the sound of the L/R channels; i.e., the sound that is output from the headphones and the AUDIO OUTPUT (MAIN) L/MONO and R jacks.

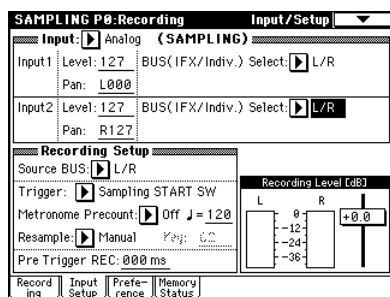

- ② **Set "Trigger" to Sampling START SW.**

With this setting, you can press the SAMPLING [REC] key to enter record-ready mode, and then press the SAMPLING [START/STOP] key to start recording.

4. Settings for the sample that will be recorded (REC Sample Setup)

- ① **Press the Recording to access the P0: Recording, Recording page.**

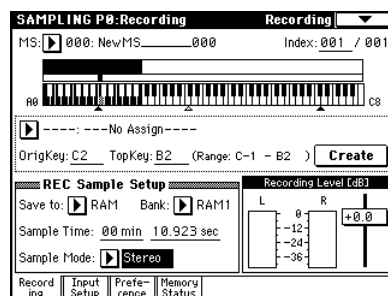

- ② **Set "Save to" to RAM.**

The recorded sample will be written into sample memory (RAM). (For details on the DISK setting, refer to p.105)

- ③ **Set "Sample Mode" to Stereo.**

With this setting, the sound of the internal LR channels can be sampled in stereo.

5. Record the sample

- ① **Press the SAMPLING [REC] key to enter record-ready mode.**

- ② **At the moment that you wish to start sampling, press the SAMPLING [START/STOP] key.**

Sampling will start.

- note** It is a good idea to allow a bit of extra time before you start and after you stop sampling.

- ③ **At the moment that you wish to stop sampling, press the SAMPLING [START/STOP] key.**

Sampling will stop.

A 140 BPM drum phrase has now been sampled. The sample will automatically be assigned to "Sample (Sample select)."

- note** Sampling will stop automatically if the remaining amount of memory reaches zero.

- ④ **Listen to the sampled sound, and assign a name to the sample.**

You can play the "OrigKey" note to hear the sound that was sampled.

After you have verified the sound, assign a name to the sample (p.40) (e.g., LOOP1-140 BPM). Up to 14 characters can be input as the name of a stereo sample (the two characters -L and -R at the end are fixed). When you assign a name to either the L or R channel, the other sample will be named automatically.

6. Make loop settings

Next we will delete unwanted portions from the sample, and adjust the settings so that the sample will be looped smoothly.

- note** By default when the power is turned on, sampled sounds will be looped automatically. (P0: Recording, Preference page "Auto Loop On" On)

- Press the [MENU] key to access the page menu, and press P2: Loop Edit.

The P2: Loop Edit page will appear.

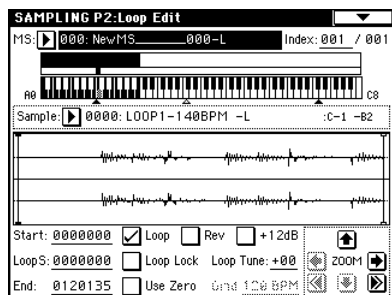

- Notice that 0000: LOOP1-140BPM-L is selected for "Sample (Sample Select)," and that the sample waveform data is displayed.

The selected sample is a stereo sample. The L and R waveforms will be shown in the upper and lower parts of the sample waveform display.

- Use "Start" to set the start address, "LoopS (Loop Start)" to set the loop start address, and "End" to set the end address.

The sample will sound as follows.

When looping is on: S → E → LoopS → E → (continue repeating LoopS → E)

When looping is off: S → E

Select "Start" (highlighted), and use the [VALUE] dial etc. to specify the location at which the sample will begin sounding. The vertical line in the display will move accordingly.

note If necessary, you can press the ZOOM buttons to expand or shrink the waveform display. Zoom will expand or contract the display beginning at the "Start," "LoopS (Loop Start)," or "End" point that is selected.

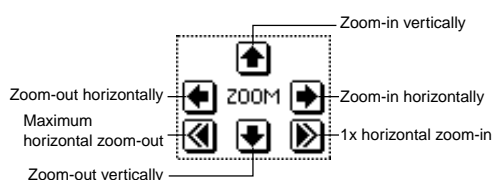

If you check "Use Zero," locations where the waveform is at zero will automatically be found and selected when you use the [VALUE] dial etc. to set "Start," "LoopS (Loop Start)," or "End" points. This makes it easy to set these points to addresses that will not produce clicks or noise in the loop.

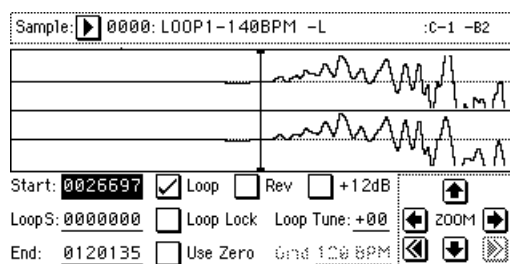

For this example, set "LoopS (Loop Start)" and "Start" to the same value.

note If desired, you can make a dotted vertical line appear in the sample waveform display to indicate the BPM. If you use this function with waveforms that have a specific BPM, it will be easier to make accurate settings for "End."

Select the page menu command "Grid" to access the dialog box.

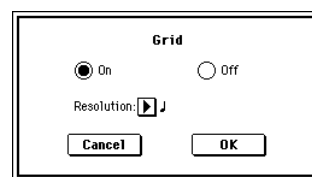

Check "Grid," set "Resolution" to ♩, and press the OK button.

Set "Grid" to 140. With these settings, vertical dotted lines will be displayed at 140 BPM quarter note intervals.

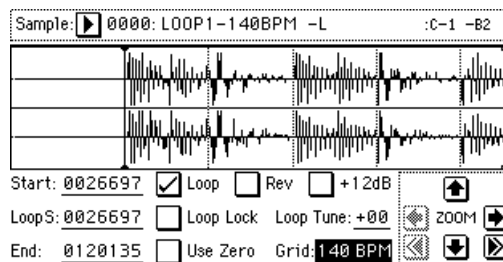

Set "End."

When "Loop" is On, the dotted vertical "Grid" lines will start at "LoopS (Loop Start)." If you want to set "End" at the end of one 4/4 measure, the fourth vertical line from the "LoopS (Loop Start)" line will be the end of the first measure. Place "End" at this vertical line.

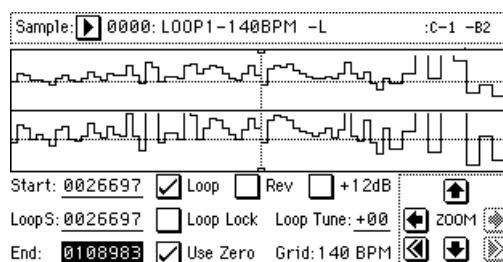

- Use "Truncate" to delete the unwanted data that is outside of the start (or loop start) and end addresses.

Select the page menu command "Truncate" to access the dialog box.

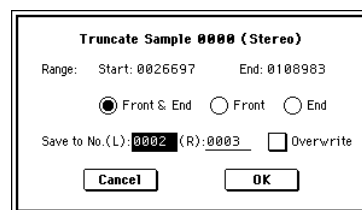

Select the Front & End radio button.

In this example, we will not change the settings of the "Save to No." and "Overwrite" check boxes, so press the OK button to execute. When you execute the operation, the truncated samples 0002: LOOP1-140B0002-L and 0003: LOOP1-140B0002-R will be automatically assigned to Index 1.

note Please refer to "A note on saving samples" (p.111) for a cautionary note regarding the "Save to No." and "Overwrite" check boxes.

Resampling an arpeggiated phrase in Program mode

You can play a program or combination, using the arpeggiator if desired, and resample your performance as audio data (sound).

As an example, this section explains how to sample an arpeggiated phrase in Program mode. Sampling can be performed in the same way in Combination or Sequencer modes as well.

note The procedure here assumes that the TRITON STUDIO is in the default state immediately after turning on the power.

1. Select the program that you want to resample

- 1 Press the [PROG] key to enter Program mode, and select program INT-A028: Rezbo.

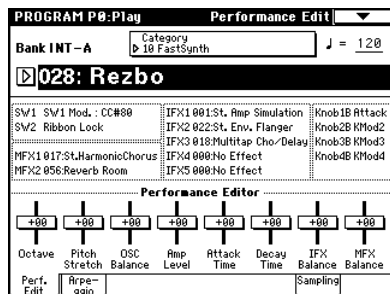

- 2 Turn the arpeggiator on (ARPEGGIATOR [ON/OFF] key LED is lit), and play the keyboard to verify that a phrase is produced.

Make sure that the arpeggio tempo “♩” is set to 120.

2. Adjust the recording level (Recording Level [dB])

- 1 Press the Sampling tab to access the P0: Play, Sampling page.
- 2 Press the SAMPLING [REC] key.

The level meter will indicate the volume of the phrase to be sampled.

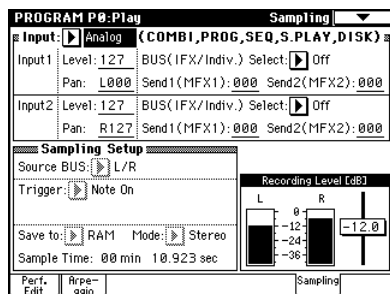

Adjust the recording level as necessary, using the “Recording Level” slider located at the right of the display.

note The power-on default setting is -12 dB. With a setting of -12 dB, CLIP will not be displayed even if the program is played at the maximum level.

- 3 When you have finished adjusting the level, press the SAMPLING [REC] key.

Press the ARPEGGIATOR [ON/OFF] key to turn off the arpeggiator.

3. Specify the recording method (Sampling Setup)

- 1 In the P0: Play, Sampling page, make the following settings for Sampling Setup.

“Source BUS”: L/R

This lets you sample the sound of the L/R channel; i.e., the sound that is output from the headphones and the AUDIO OUTPUT (MAIN) L/MONO and R jacks.

“Trigger”: Note On

With this setting, sampling will begin the instant you play the keyboard.

“Save to”: RAM

The sample will be written into sample memory (RAM).

“Mode”: Stereo

The sound will be sampled in stereo.

note If desired, you can set “Sample Time” a bit longer than necessary, and then after sampling, use editing commands in Sampling mode (such as TRUNCATE) to delete any unwanted portion at the beginning or end of the sample.

If the tempo “♩” is 120 and the time signature is 4/4, it will take two seconds to play one measure. If you want to sample one measure, a sampling time of 00 min 02.000 sec will be the exact length.

4. Make settings for the sample that will be recorded

- 1 Select the page menu command “Select Bank & Smpl No.” to access the dialog box.

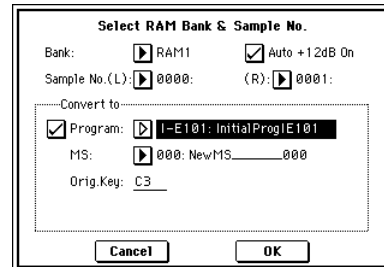

- 2 Set “Bank,” “Sample No.(L),” and “(R)” to specify the sample memory (RAM) and sample number into which the sample will be written.

If the above “Mode” is Stereo, specify (L) and (R).

- 3 In the Convert to area, specify the number of the program (into which the sample will be converted), the multisample name, and the key assignment.

Check the check box and select one of the bank INT-E initialized programs as the conversion-destination program number.

- 4 Press the OK button to finalize the settings.

5. Record the sample

- 1 Press the ARPEGGIATOR [ON/OFF] key to turn it on.

Press the SAMPLING [REC] key.

Press the SAMPLING [START/STOP] key to enter record-ready mode.

- 2 Play the keyboard. Recording will begin at the instant you play a note.

All of the sounds you play from the keyboard and controllers will be recorded in the sample.

- ③ Press the SAMPLING [START/STOP] key to stop recording.

note Sampling will end automatically when the specified "Sample Time" is reached.

6. Listen to the sample and edit it

- ① Press the Perf. Edit tab to select the P0: Play, Performance Edit page, and select the program into which the newly-recorded sample was converted.

INT-E: 101 was selected in the example shown here, so press the [INT-E] key, then numeric keys [1], [0], and the [1] key.

- ② Play the C3 note on the keyboard to hear the sound that was resampled.

note REALTIME CONTROLS knobs 1–4, the Performance Editor, and the various parameters in P1: Edit-Basic–P9: Edit-Master Effect can be used to edit the program for the sound you resampled, for example by adjusting the filter, EG, or effects. (see p.34, 67)

note If you want to adjust the loop point or other settings of the sample, edit these parameters in Sampling mode. (see p.43)

Sample an arpeggiated drum phrase together with an externally-input guitar

Here's how you can resample an arpeggiated performance together with an external audio input source.

In this example, we will explain how a guitar connected to the AUDIO INPUT jack can be played along to a drum pattern played by the TRITON STUDIO, and how both can be sampled together.

note Sampling can be performed in a similar way in Combination and Sequencer modes as well as in Program mode.

note The procedure given here assumes that you are starting from the default state immediately after power-on.

1. Select the program that you want to sample

- ① Press the [PROG] key to enter Program mode, and select the INT-B020: Processed Kit program.
- ② Turn on the arpeggiator (ARPEGGIATOR [ON/OFF] key LED is lit), and play the keyboard to make sure that a drum phrase is sounded.

Press the Arpeggio tab, and make sure that "Latch" is checked.

Also adjust the arpeggiator tempo "J" as desired.

- ③ Press the ARPEGGIATOR [ON/OFF] key to turn off the arpeggiator.

2. Connect your guitar and make input settings

- ① Connect your guitar to the rear panel AUDIO INPUT 1 jack.

Set the AUDIO INPUT [MIC/LINE] switch to the LINE position, and set the [LEVEL] knob to approximately the center position.

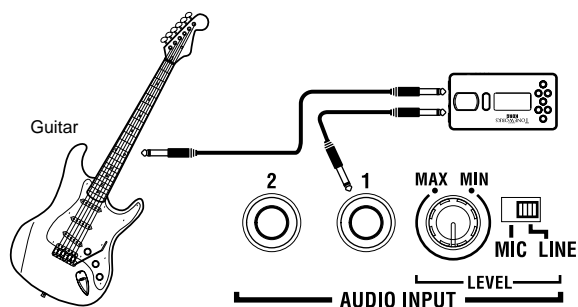

⚠ If you are using a guitar with passive pickups (i.e., without an internal pre-amp), the mismatch of impedance levels will make it difficult to sample at an appropriate level. You should route the signal from the guitar through a pre-amp or effect unit.

- ② Press the Sampling tab to access the Sampling page.

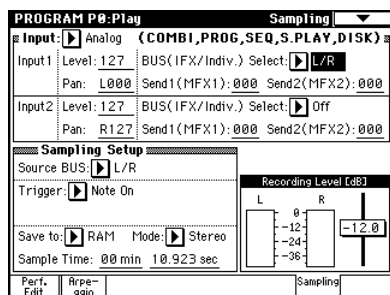

- ③ Set the parameters so that the signal from the AUDIO INPUT 1 jack will be sent to the L channel.

Make the following settings.

“Input”: Analog

Input 1 “Level”: 127, “Pan”: as desired, “BUS Select”: L/R

3. Set the recording level (Recording Level [dB])

- ① Play your guitar at the volume that you will be recording.

If the display indicates “ADC OVERLOAD !!” (AD converter input overload), turn the rear panel [LEVEL] knob toward MIN to adjust the level appropriately.

note The best audio quality will be obtained at the highest possible level that does not cause an overload; i.e., a level that is slightly below the point where “ADC OVERLOAD !!” is displayed.

- ② Press the SAMPLING [REC] key.

Play your guitar, and the level meter will indicate the volume at which the guitar will be sampled.

Press the ARPEGGIATOR [ON/OFF] key to turn it on, play the keyboard to start the arpeggio, and play your guitar while adjusting the final volume.

Adjust the recording level as necessary, using the “Recording Level” slider located at the right of the display.

note The power-on default is -12 dB. With a setting of -12 dB, CLIP will not be displayed even if the program drum pattern and the guitar are played at the maximum level.

note If the balance between instruments is not to your liking, use the [LEVEL] knob or the performance editor “Amp Level” to adjust the balance.

- ③ When you have finished making adjustments, press the SAMPLING [REC] key.

Press the ARPEGGIATOR [ON/OFF] key to turn off the arpeggiator.

4. Specify the recording method (Sampling Setup)

- ① In the Sampling page, set the following Sampling Setup parameters.

“Source BUS”: L/R

“Trigger”: Sampling START SW

“Metronome Precount”: 4

“Save to”: RAM

“Mode”: Stereo

“Sample Time”: as desired

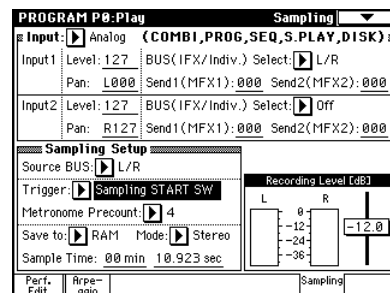

With these settings, if you press the SAMPLING [REC] key to enter recording-standby mode and then press the SAMPLING [START/STOP] key, recording will begin after a four-beat count.

5. Specify the sample that will be recorded

Make settings as described in “4. Make settings for the sample that will be recorded” (p.45).

If you omit making settings at this point and simply continue with the settings of p.45, the sample will be assigned to the next higher key of the same program number.

6. Record the sample

- ① Press the ARPEGGIATOR [ON/OFF] key to turn it on.

- ② Press the SAMPLING [REC] key to enter recording-ready mode.

When you press the SAMPLING [START/STOP] key, a count-down will begin. Play the keyboard during the count-down.

After a four-beat count-down, recording will start. Play your guitar. The arpeggiator will also start after the count-down.

- ③ Press the SAMPLING [START/STOP] key to stop recording.

note Sampling will also end automatically when the specified “Sample Time” is reached.

- ④ Press the ARPEGGIATOR [ON/OFF] key to turn it off.

7. Listen to the sample

Now you can listen to the sample that was recorded. (“6. Listen to the sample and edit it” p.46)

Examples of sampling settings

○ **Resampling only the sound of the TRITON STUDIO (e.g., arpeggiator and/or keyboard performance)**

“Input”: Analog

Input1 “BUS Select”: Off

Input2 “BUS Select”: Off

“Source BUS”: L/R

“Recording Level”: -12.0

“Auto +12dB On”: On (checked)  PG p.5, 57

○ **Resampling the sound of the TRITON STUDIO (arpeggiator and/or keyboard performance) together with the input sound from the AUDIO INPUT 1 jack**

“Input”: Analog

Input1 “BUS Select”: L/R, “Pan”: C064 or as desired

Input2 “BUS Select”: Off

“Source BUS”: L/R

“Recording Level”: -12.0

“Auto +12dB On”: On (checked)  PG p.5, 57

○ **Sampling only the stereo input sound from the AUDIO INPUT 1 and 2 jacks while you listen to the sound of the TRITON STUDIO (arpeggiator etc.)**

“Input”: Analog

Input1 “BUS Select”: 1/2, “Pan”: L000

Input2 “BUS Select”: 1/2, “Pan”: R127

“Source BUS”: Indiv.1/2

“Recording Level”: 0.0

“Auto +12dB On”: Off (unchecked)  PG p.5, 57

In this case, the sound that is input to AUDIO INPUT 1 and 2 will be output only to AUDIO OUTPUT (INDIVIDUAL) 1 and 2.

Using the metronome

It is convenient to use the metronome when you want to play a program or combination at a specific tempo and sample your performance.

To access the metronome settings, use the Program or Combination P0: Play, Sampling page menu command “Metronome Setup.” We recommend that you set “BUS (OUTPUT) Select” to either 3 or 4, and connect the (INDIVIDUAL) 3 or 4 jack to your mixer so that the metronome can be monitored via your mixer.

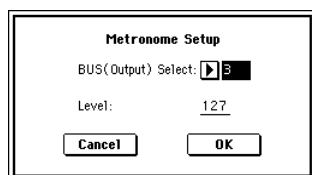

Producing a song

This section explains how to use the TRITON STUDIO's internal sequencer. The example procedures described here will cover realtime recording and step recording, as well as various convenient functions provided by the internal sequencer, such as template songs, preset patterns, and the arpeggiator.

There are many other recording methods and functions (see p.80), but working through this section will give you a basic understanding of the song production process.

note This explanation assumes that you are starting from the default state immediately after power-on.

Creating the basic song

1. Loading a template song, and copying preset patterns (drum phrases)

- 1 Press the [SEQ] key to enter Sequencer mode.



- 2 Load a template song.

Press the page menu button to access the page menu, and press "Load Template Song."

A dialog box will appear.



Press the popup button located at the right of "From," and select P13: Acid Jazz from the menu.

note There are 16 **template songs**, each containing program, pan, volume, and effect settings suitable for various styles of music. By loading a template into a song, you can begin recording immediately without having to make the same frequently-used settings each time.

If you want to specify the program and volume settings yourself from scratch, refer to "Preparations for recording" (see p.82).

Check the "Copy Pattern to Track too?" check box. If this is checked, a drum pattern will be copied to the song after the template song is loaded.

Press the OK button to load the template song.

A dialog box will appear.

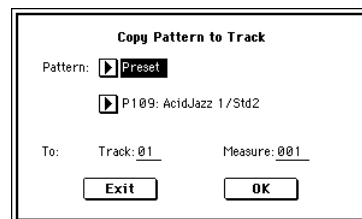

Make sure that Preset, P109: AcidJazz 1/Std2 is selected at the right of "Pattern." If not, use the VALUE controller to select it.

You can press the SEQUENCER [START/STOP] key to hear the selected pattern. To stop, press the [START/STOP] key once again.

Press the OK button to copy the pattern.

The "Measure" value will change from 001 to 009. This indicates that the pattern has been copied from measure 1 to measure 8, and that the next time you press the OK button, the pattern will be copied from measure 9.

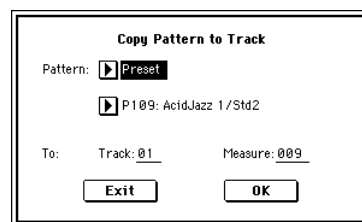

Press the Exit button.

In the Sequencer P0: Play/REC, Program T01-08 page, the "Song Select" field will indicate S000: Acid Jazz.

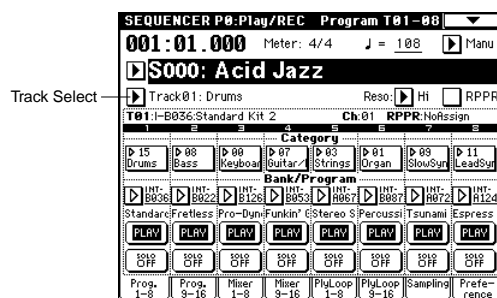

note Preset patterns can be used in a song at any time. This can be done by using the page menu commands "Put To Track" or "Copy To Track" (Sequencer P6: Pattern/RPPR, Pattern Edit page) (see PG p.77).

- ③ When you play the keyboard, you will hear the drum program for track 1 of the template song.
- ④ Press the popup button located at the left of “Track Select,” and select Track 02: Bass. When you play the keyboard, you will hear a bass sound.

“Track Select” is the track that will be used to record/play song data. Normally, the track selected here can be played from the keyboard, and during recording, your performance will be recorded on this track (in cases other than Multi REC or Master Track).

Next select T03–T08 in order, and play them from the keyboard. (The TRITON STUDIO has sixteen sequence tracks, but this template song specifies only tracks 1–8.) Select Track03: Elec. Piano.



- ⑤ Press the SEQUENCER [START/STOP] key to play back the preset pattern that you copied. Play the keyboard while you listen to the drum pattern.
- ⑥ Press the SEQUENCER [START/STOP] key to stop.

2. Repeatedly playing specific measures of a track (Track Play Loop)

Here’s how to use Track Play Loop to repeatedly play back a drum phrase.

- ① Press the PlyLoop tab to access the P0: Play/REC, PlayLoop T01–08 page.



- ② Check track 1 “Track Play Loop,” leave “Loop Start Measure” as it is, and set “Loop End Measure” to 008.
- ③ When you press the SEQUENCER [START/STOP] key, the drum phrase will be played back repeatedly.

When the playback has repeated for the number of measures in the song as specified by “Length” (the power-on default is 64 measures), it will stop automatically.

note By using “Play Intro” you can begin the loop after adding an introduction (PG p.55).

note Track Play Loop will continue repeating for the number of measures specified by “Length.” If you want to limit the number of repetitions or place other performance data (e.g., a drum fill-in) in that track, you will need to expand the pattern into actual performance data. Use the page menu command “Repeat Measure” P5: Edit, Track Edit page to specify the number of playback repetitions and expand the pattern as playback data. In the sample illustration below, performance data will be created to play measures 1–8 of track 1 for four times (i.e., 32 measures).

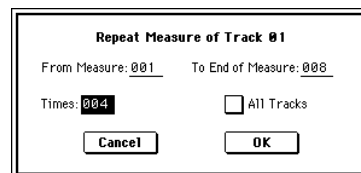

3. Recording the bass track

- ① If playback is occurring, press the SEQUENCER [START/STOP] key to stop playback. Press the [LOCATE] key to return to the beginning of the song. The location will indicate 001:01.000.
- ② Press the [EXIT] key, and then press the Prog. 1–8 tab to access the P0: Play/REC, Program T01–08 page.
- ③ Use “Track Select” to select the track that you want to record. In this example, select Track02: Bass.



Press the SEQUENCER [START/STOP] key to start playback, and practice playing the phrase that you want to record.

When you are finished rehearsing, press the SEQUENCER [START/STOP] key to stop playback. Press the [LOCATE] key.

note When the power is turned on, the Recording Setup of the TRITON STUDIO will be set to Over Write recording, in which newly recorded data will be overwritten. For details on other recording modes, refer to p.83 and PG p.57.

note When recording rapid or difficult phrases, you can slow down the tempo and record at a more comfortable tempo. Simply adjust the “♩ (Tempo).” After recording, restore the original tempo.



note You can use the **Quantize and Resolution** functions to correct the timing of your performance as it is recorded.

For example during realtime recording, suppose that you input eighth notes at slightly inaccurate timing, as shown in line 1 of the diagram below. If you set “**Reso**” (Resolution) to ♩ and performed realtime recording, the timing would automatically be corrected as shown in line 2. With a setting of **Hi**, the performance will be recorded with the exact timing at which it was played.



Independent of this function, there is also a page menu command “**Quantize**” (P5: Track Edit, Track Edit page) that can be used to correct the timing of performance data that has already been recorded. If data (recorded without using Realtime Quantize) falls at the timings shown in the above figure 1, then when played back, it will be corrected to the timings shown in figure 2 if you set “**Quantize**” to a “**Resolution**” of ♩ and press the **OK** button.

④ **Press the SEQUENCER [REC/WRITE] key.**

You will hear the metronome. The TRITON STUDIO will be in record-ready mode. (Refer to PG p.58 for details on metronome settings.)

⑤ **Press the SEQUENCER [START/STOP] key.**

After a two-measure count, recording will begin.

Play the keyboard for about 16 measures, and record your performance.

If you make a mistake or decide to re-record, press the [START/STOP] key to stop recording, and press the [COMPARE] key.

When you press the [COMPARE] key to execute the Compare function, you will return to the state prior to recording. (Refer to p.97 for the content that can be compared in Sequencer mode.)

⑥ **When you are satisfied with your performance, press the SEQUENCER [START/STOP] key to stop recording.**

note For example if your performance in measures 5–8 was the best take, you can use the Track Play Loop function to repeatedly play back just this portion. In the P0: Play/REC, PlayLoop T01–08 page, check “**Track Play Loop**” for track 2, set “**Loop Start Measure**” to 005, and set “**Loop End Measure**” to 008.



When you press the SEQUENCER [START/STOP] key, repeated playback will begin.

note After you press the SEQUENCER [START/STOP] key to stop playback, we recommend that you press the [LOCATE] key to return to the beginning of the song. After recording, you will automatically return to the measure at which recording began.

4. Recording arpeggio patterns

The performance of an arpeggio pattern can be recorded into a song. With the settings of this template song, the arpeggiator will function on track 4.

① **In “Track Select,” choose Track04: Guitar.**



② **Press the ARPEGGIATOR [ON/OFF] key.**

③ **Press the SEQUENCER [START/STOP] key and play single notes or chords.**

Verify that arpeggios are sounded in synchronization with the tempo of the drum and bass performance, and rehearse your performance.

④ **Press the SEQUENCER [START/STOP] key to stop playback.**

Then press the [LOCATE] key to move the location to the beginning of the song.

⑤ **Start recording.**

Press the SEQUENCER [REC/WRITE] key, and then press the SEQUENCER [START/STOP] key.

If you play notes on the keyboard during the count-in, the arpeggio will begin at the same time that recording begins, and then that pattern will be recorded.

Play the keyboard for about 16 measures and record your performance.

Press the SEQUENCER [START/STOP] key to stop recording.

If you made a mistake or would like to re-record, you can use the Compare function (press the [COMPARE] key) to re-record as many times as you wish.

note The note data that was generated by the arpeggio pattern will be recorded. If you change the ARPEGGIATOR [GATE] or ARPEGGIATOR [VELOCITY] knob settings while recording an arpeggio pattern, this data will also be recorded, but it will not be possible to add changes by overdubbing [GATE] or [VELOCITY] data afterward for those notes.

5. Recording other tracks

- As described in “Recording the bass track,” use “Track Select” to select Track03: Elec. Piano, and record about 16 measures.

6. Step recording

The TRITON STUDIO provides two main methods of recording a song. The first is **realtime recording**, in which your performance on the keyboard and operation of the joystick and other controllers are recorded in realtime. This is how we recorded the bass and electric piano tracks in the preceding sections.

The second method is **step recording**, in which you can specify the timing, note length, and velocity of each note. In the LCD screen, and use the keyboard to input the pitch of the note. Only the note-on/off data is recorded. Step recording is suitable when you want to create a distinctive mechanical feel, or when you want to record phrases that would be impossible or too rapid to play “live.”

note Rapid phrases can also be recorded in realtime by temporarily slowing down the sequencer tempo.

Here’s the procedure for step recording.

- Press the [MENU] key to access the Jump menu, and press P5: Track Edit.

The P5: Track Edit, Track Edit page will appear.

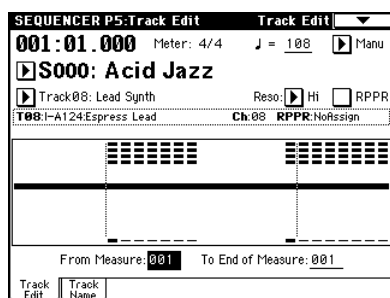

- Set “Track Select” to Track 08: Lead Synth.

For this example we will input a lead performance using an analog synthesizer sound.

- Set “From Measure” to 001.

With this setting, step recording will begin from measure 1.

- Press the page menu button to access the page menu, and press “Step Recording.”

A dialog box will appear.

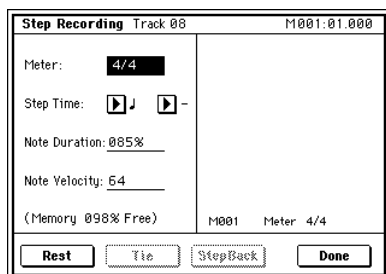

- Set “Step Time” to specify the basic timing value at which you will input notes and rests.

In the popup menu at left, you can specify a value in the range of ♩ (whole note)–♩ (32nd note). For this example, select ♩ (16th note).

If you want to input triplets or dotted notes, use the popup menu at the right to select “3” for triplets, or “.” for dotted notes. Select “-” if you want to use the unmodified length of the note that is selected at the left.

“Note Duration” indicates the length that the note itself will sound. Smaller values will produce a staccato note, and larger values will produce a legato note. For this example, leave this setting unchanged.

“Note Velocity” is the velocity (playing strength), and larger values will produce a louder volume. Set this to about 090.

If you select **Key** for this parameter, the velocity with which you actually play the keyboard will be input.

- On the keyboard, press and then release the first note that you want to input.

The data you input will appear in the LCD screen as numerical values. In the upper right, **M001 01.000** will change to **M001 01.048**. The next note you input will be placed at this location.

Continue pressing notes to input a melody.

You can also delete notes or rests, or input rests or ties.

- To delete a note or rest that you input, press the **Step Back** button. The previously-input note will be deleted.
- To input a rest, press the **Rest** button. This will input a rest of the “Step Time” value.
- To modify the length of a note, you can modify the “Step time” value before you input the note. However if you want to extend the **length (tie) of the note**, press the **Tie** button. At this time, the previously-input note will be extended by the length of “Step time.”

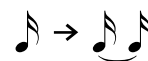

note If you want to check the note that you will input next, press the [PAUSE] key. In this state, playing a key will produce sound, but will not input a note. Press the [PAUSE] key once again to cancel the record-pause state, and resume input.

note To input a chord, simultaneously press the notes of the desired chord. Even if you do not press them simultaneously, notes that were pressed before you took your hand off of all keys will be input at the same location.

However in the above example, the program of track 8 will not sound chords. This is because the program is set to mono mode, and the song follows the setting of the program.

- When you are finished inputting, press the Done button.
- Press the SEQUENCER [START/STOP] key to play back.

- When you begin step recording, all data that follows the measure where you began recording will be erased from that track.

You need to be aware of this if you begin step recording from a measure mid-way through the song.

If you want to re-input data into a measure that already contains data, perform step recording in another un-recorded track, and execute "Move Measure" or "Copy Measure" (PG p.72).

If you want to edit or add to the recorded data, you can use the "Event Edit" function (PG p.69).

7. Using controllers to record tonal changes

Let's try using the realtime controllers and the joystick to add effects to the performance that we just step-recorded on track 8.

- Press the [EXIT] key, and then press the Preference button to move to the P0: Play/REC, Preference page.

- Set the "Recording Mode" to Over Dub.

Over Dub allows you to add to a previously-recorded track.

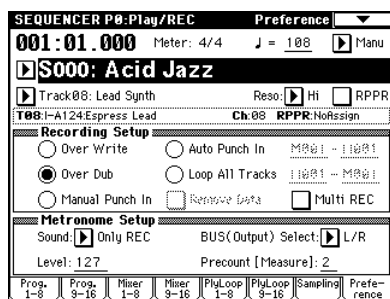

- For "Track Select," make sure that Track08: Lead Synth is selected.

Press the SEQUENCER [START/STOP] key to start playback, and operate the realtime controllers and joystick to rehearse. When you are finished rehearsing, press the SEQUENCER [START/STOP] key to stop. Press the [LOCATE] key.

- Start recording.

Press the SEQUENCER [REC/WRITE] key, and then press the SEQUENCER [START/STOP] key.

After a two-measure count-in, recording will begin.

Operate the LFO CUTOFF or RESONANCE/HPF realtime controllers or the joystick ($\pm Y$ axis) to record their movements.

When you are finished performing, press the SEQUENCER [START/STOP] key.

If you make a mistake or want to re-record, press the [COMPARE] key to execute the Compare function, and then re-record.

Recording the drum part

In this explanation, we used the TRITON STUDIO's built-in patterns to create the drum part, but if you want to input the drum part yourself, it will be convenient to set "Recording Mode" to Over Dub for recording. (p.84) It is best to use realtime recording ("3. Recording the bass track" p.50) to record the rhythm instruments in the order of bass drum, snare, and hi-hat.

Naming the song and tracks

It's a good idea to assign a name to each song and track so that they can be easily identified.

Naming a song

- Press the [EXIT] key to access P0: Play/REC.

The "Rename Song" page menu command can also be selected from P2, P3, P4, or P7, as well as from P0.

- Press the page menu button to access the page menu, and press "Rename Song."

- A dialog box will appear. Press the text edit button and input the desired song name.

For the procedure of inputting a name, refer to p.40, 56.

- When you are finished inputting the name, press the OK button twice to finish the procedure. (p.40)

Naming a track

- Press the [MENU] key to select P5: Track Edit, and press the Track Name tab.

The P5: Track Edit, Track Name page will appear.

- Press the text edit button for the track whose name you want to edit, and input the desired name for that track.

For the procedure of inputting a name, refer to p.40, 56.

- When you are finished inputting the name(s), press the OK button.

note You can also assign a name to each cue list and user pattern.

Saving the song

Remember to save the song you created.

note Beginning on page 88 is a description of how you can perform further editing on the song you created here in “Quick Start” and how you can assign it to a cue list, so we recommend that you save the song you created here for further use.

 On the TRITON STUDIO, this data will be lost when the power is turned off.

- ① Perform steps ①–④ of “Saving sample data” (p.41).
- ② Press the page menu button to access the page menu, and press “Save SEQ.”

The Save Songs and Cue Lists Data dialog box will appear.

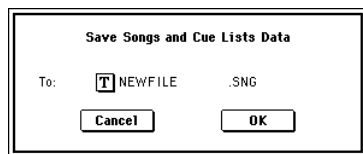

- ③ When the dialog box appears, press the text edit button to access the text dialog box, input a name for your song.

Assign a filename of SEQ_DM1 to the song you created in this “Quick Start” section, and press the **OK** button.

- ④ Press the **OK** button to save the data.

If you have assigned the name described above, a file named SEQ_DM1.SNG will be created.

Basic functions

Saving data

Types of data that can be saved

On the TRITON STUDIO, there are three ways to save data: **writing to internal memory**, saving on **media** (floppy disk, internal hard drive, CD-R/RW, hard disk and other removable media etc.), and **MIDI data dump**.

Writing to internal memory

The following types of edited can be written into the internal memory.

- **Program**
Programs 0–127 in banks INT-A–INT-F, EXB-A–EXB-G (However, bank INT-F is available only if the EXB-MOSS option is installed.)
- **Combination**
Combinations 0–127 in banks INT-A–INT-E, EXB-A–EXB-G
- **Global settings**
(Global P0: Basic Setup–P4: Category Name)
- **User drum kits 00** (I-A/B)–143 (User)
- **User arpeggio patterns U000** (I-A/B)–U506 (User)
- **User template songs U00–U15**
Song settings such as the song name and tempo, track settings (p.81), arpeggiator settings, and effect settings can be saved (written) to internal memory. However, the musical data for song tracks and patterns are not saved to internal memory. Furthermore, settings that govern how the musical data is played back such as “Meter,” “Metronome,” “Play/Mute,” “Track Play Loop (including Start/End measure),” and RPPR settings will not be saved either. Use the Sequencer mode page menu command “Save Template Song” to write this data (p.54).

⚠ If multisamples or samples from the **RAM** bank are used in the **Multisample** or **Drum Kit** of a program, you should be aware that these multisamples or samples cannot be written into memory. This means that if you turn the power of and then on once again, programs or combinations that use such multisamples or samples will not sound as intended. To reproduce such programs or combinations, the necessary multisamples or samples must be saved on media (such as floppy disk, hard disk, CD-R/RW and removable disk etc.), and then reloaded.

⚠ Data that you edit in Sequencer, Song Play, or Sampling cannot be saved in internal memory by the Write operation.

Saving to various types of media

The following data can be saved to various types of media.

- **.PCG file:**
Programs, combinations, global settings, user drum kits, user arpeggio patterns (The data that was checked in the check boxes of the Save dialog box will be saved.)
- **.SNG file:** Song and cue list data
- **.KSC, .KMP, .KSF files:**
Lists of sample and multisamples (.KSC file), multisamples (.KMP file), samples (.KSF file).
- **.MID file:**
Saves a Sequencer mode song in Standard MIDI File (SMF) format.
- **.EXL file:**
System exclusive data from an external device that was saved on the TRITON STUDIO (This allows the TRITON STUDIO to be used as a data filer.)
- **.JKB file:**
Jukebox lists are saved in Song Play mode (p.122). All other types of file are saved in Disk mode.
- **.WAV and .AIF files:**
A sample you recorded can be exported (written) as a WAVE file or AIFF file.
- **.KCD file:**
Audio track list

MIDI data dump

The following types of data can be transmitted as a MIDI data dump and saved on an external data filer or other device.

- **Programs, combinations, global settings, user drum kits, and user arpeggio patterns**
- **Songs, cue lists**

In the case of a combination, the category you specify here will be used when you select a combination by category in Combination P0: Play "Category" (Category/Combination Select).

- ⑤ Use "To" to specify the bank and number of the writing destination program/combination.

Use the VALUE controllers or the BANK keys to make your selection.

- ⑥ To execute the Write operation, press the OK button. To cancel without executing press the Cancel button.

When you press the OK button, the display will ask "Are you sure?" When you press the OK button once again, the data will be written.

Using the (SEQUENCER) [REC/WRITE] key to write

This method can only be used to re-write (update) the selected program/combination number.

- ① Press the SEQUENCER [REC/WRITE] key.

The following Update Program/Update Combination dialog box will appear.

The screen shown is for Program mode

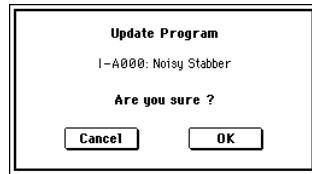

- ② To write the data, press the OK button. To cancel without writing, press the Cancel button.

Assigning a name (Rename)

You can modify the name of an edited program, combination, song, drum kit, user arpeggio pattern, multisample or sample etc..

You can also modify the category names for programs and combinations.

These renaming operations can be performed in the following pages.

Program	Program P0...9 page menu command: Write Program
Combination	Combination P0...9 page menu command: Write Combination
Song	Sequencer P0, 2...4, 7 page menu command: Rename Song
Cue List	Sequencer P1 page menu command: Rename Cue List
Track	Sequencer P5: Track Name
Pattern	Sequencer P6: Pattern Name
Multisample	Sampling P0...4 page menu command: Rename MS
Sample	Sampling P0...4 page menu command: Rename Sample
Drum Kit	Global P5 page menu command: Rename Drum Kit
User arpeggio pattern	Global P6 page menu command: Rename Arpeggio Pattern
Program category	Global P4: Program Cat.
Combination category	Global P4: Combination Cat.

File	Disk Save: Save All... Save Audio CD Track List, Utility page menu command: Rename
mLAN Nick Name	Global P0: Nick Name (if the EXB-mLAN is installed)

- Press the text edit button to access the text edit dialog box.

For an example of how to input a name, refer to p.40.

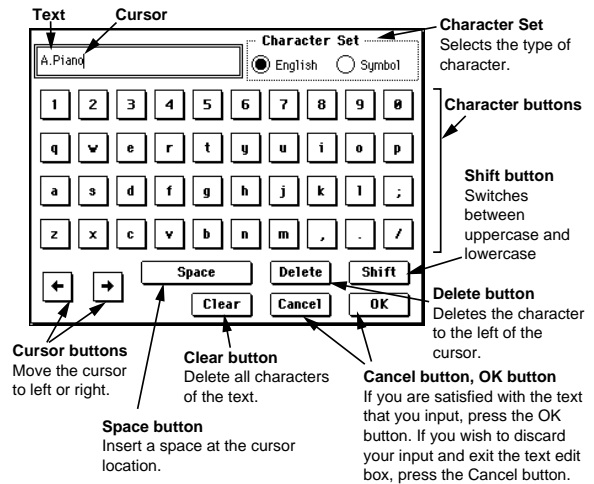

Memory protect

To prevent programs, combinations, songs, user drum kits, and user arpeggio patterns from being overwritten accidentally, the TRITON STUDIO provides a Memory Protect setting that prohibits writing to memory.

Before you save edited data or load data from floppy disk, hard disk or other external media, use the following procedure to turn the memory protect off (uncheck the appropriate check box).

You must also turn memory protect off before loading the above data from media or via a MIDI data dump, or before recording in Sequencer mode.

- ① Press the [GLOBAL] key to enter Global mode.
- ② After pressing the [MENU] key, press either P0: Basic Setup or the [0] key.
- ③ Press the System Pref. tab.

The System Preference page will appear.

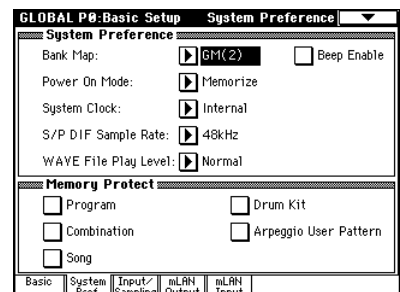

- ④ Press the "Memory Protect" check box for the type of data you wish to write to internal memory, so that the box is unchecked. When the box is unchecked, Memory Protect is off, and data of this type may be written to internal memory.

About the Edit Buffer

When you select a program or combination in Program P0: Play and Combination P0: Play, the program or combination data is called into the “edit buffer.”

When you modify the parameters in P0: Play or in the Edit pages P1–P9 of Program mode or Combination mode, the changes you make will affect the data in the edit buffer.

If you wish to save this modified data into internal memory, you must perform the Write operation.

When you perform the Write operation, the data in the edit buffer is written to the specified program number or combination number of the specified bank.

If you select another program or combination without writing, the data of the newly selected program or combination will be called into the edit buffer, and your changes will be lost.

- When you press the [COMPARE] key in Program mode or Combination mode, the data from memory (i.e., the contents that were written into memory) will be temporarily called into the edit buffer. This allows you to compare the settings you are editing with the original un-edited settings.

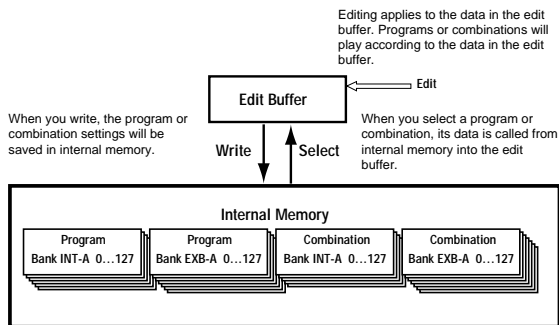

Writing global settings, user drum kits, and user arpeggio patterns

The settings you edit in Global mode can be written into internal memory. This is done using the operations **Write Global Setting**, **Write User Drum Kits**, and **Write User Arpeggio Patterns**. If you wish to use these edited settings after you turn the power off, be sure to write the data first.

There are two ways to write global settings, user drum kits, and user arpeggio patterns.

- Before you write a user drum kit or user arpeggio pattern, the Global mode memory protect setting must be turned off (☞ “Memory protect”).
- The user arpeggio pattern parameter settings “Tempo,” “Pattern,” “Octave,” “Resolution,” “Sort,” “Latch,” “Key Sync,” and “Keyboard” are set independently in the Program, Combination, and Song modes. These settings are not saved when you perform the Write operation described here. If you have edited these parameters in Program or Combination mode you must return to that mode to write them.

Using a page menu command to write

- To write global settings (the various settings in Global P0–P4), press the page menu command “Write Global Setting” in Global P0–P4.

The Write Global Setting dialog box will appear.

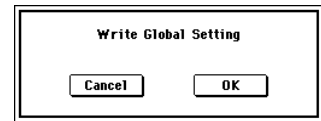

To write user drum kits, press the page menu command “Write Drum Kits” in Global P5.

The Write Drum Kits dialog box will appear.



To write user arpeggio patterns, press the page menu command “Write Arpeggio Patterns” in Global P6.

The Write Arpeggio Patterns dialog box will appear.



note The same dialog box will also appear if, in each of the above pages, you hold down the [ENTER] key and press the [0] key.

- To execute the Write operation, press the OK button. To cancel, press the Cancel button.

When you press the OK button, the display will ask “Are you sure?” Press the OK button once again to write the data.

Using the (SEQUENCER) [REC/WRITE] key to write

- ① In the following pages, press the SEQUENCER [REC/WRITE] key.

A dialog box will appear.

Global settings: Global P0-P4
User drum kits: Global P5
User arpeggio patterns: Global P6

The example shown is for Update Arpeggio Patterns

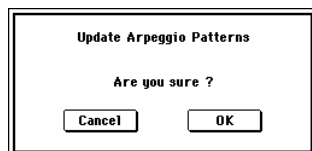

- ② To execute the Write operation, press the OK button. To cancel, press the Cancel button.

Memory in Global mode

When the power is turned on, the Global mode data is called from internal memory into the Global mode memory area. Then when you modify the parameters in Global mode, the data in the memory area will be modified. If you wish to save this modified data in internal memory, you must Write it.

When you write, the data in the memory area will be written into the global settings, drum kits, and arpeggio patterns of internal memory.

If you turn off the power without writing, the modified data in the memory area will be lost.

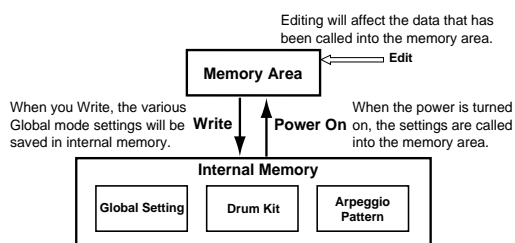

Saving on media

For details on the data that can be saved on storage media. ("Types of data that can be saved" p.55).

- ▲ Song data and cue lists in the TRITON STUDIO's Sequencer mode, as well as multisamples and samples cannot be written into internal memory. This data will disappear when the power is turned off. If you want to keep this data, you must save it on a floppy disk, the internal hard drive, the CDRW-1 option, or an externally-connected SCSI CD-R/RW or other storage device (hard disk, removable disk etc.). Other types of data can also be saved on storage media. Even if you later modify this data, you will always be able to reload the original settings. It is a good idea to save your settings whenever you have created something that you like.

Types of media that can be used

Floppy disks

You can use MS-DOS format 3.5 inch 2HD and 2DD floppy disks. The formatted capacity of a floppy disk is 1.44 MB for a 2HD disk (18 sectors/track), and 720 KB for a 2DD disk (9 sectors/track).

Internal hard drive

This supports MS-DOS format FAT16 and FAT32.

CDRW-1 option (CD-R/RW)

This supports UDF format. UDF format CD-R/RW discs can be written or read. (Packet writing is supported p.299).

You can also record/play CD-DA (audio CD), and load ISO 9660 (level 1) format data.

External SCSI storage media

Data can be stored on external SCSI storage media such as a hard disk, MO, Zip, JAZ, or ORB disk.

For details on CD-R/RW, refer to the above "CDRW-1 option (CD-R/RW)."

note When you insert media for the first time after turning on the power, or when you exchange disks, touch the LCD screen. so that the TRITON STUDIO will detect the media. When the media has been detected, the LCD screen will display information for that media.

note If two or more media are detected, use "Drive select" to switch between media.

Formatting media

You can format a floppy disk, the internal hard drive, external SCSI media, or CD-R/RW media. Newly purchased media or media that has been used by another device cannot be immediately used by the TRITON STUDIO. In order to use such media on the TRITON STUDIO, you must first format it. For the formatting procedure, refer to "Format" (PG p.170).

- ▶ The internal hard drive has already been formatted when it is shipped from the factory.
- ▶ It is not necessary to format a CD-R/RW disc that you will use to create an audio CD.
- ▶ Media must be formatted by the TRITON STUDIO. It may not be possible to recognize media that was formatted on a device other than the TRITON STUDIO.

How to save data

As an example, we will explain how to save the following data.

- Internal memory programs, combinations, global settings, user drum kits, user arpeggio patterns
 - Songs, cue lists
 - Multisamples and samples created in Sampling mode etc.
- ▶ If you are saving this data on floppy disk, more than one disk may be necessary.

- ① **Prepare the media on which you want to save the data.**

If you want to save data on a floppy disk, insert the floppy disk into the floppy disk drive of the TRITON STUDIO.

For details on handling floppy disks, please be sure to read "Cautions when handling floppy disks" (PG p.62).

If you want to use the CDRW-1 option to save data on a CD-R/RW disc, insert a CD-R/RW disc into the drive.

For details on handling CD-R/RW discs, please be sure to read "Cautions when handling CD-R/RW discs." If you will be using the disc to save data, it must be formatted. (PG p.170, 295)

If you want to save data on external media such as a SCSI-connected hard disk, make sure that the external SCSI drive is connected. (PG p.298)
Format the media if necessary. (PG p.170)

- ② **Press the [DISK] key to enter Disk mode.**

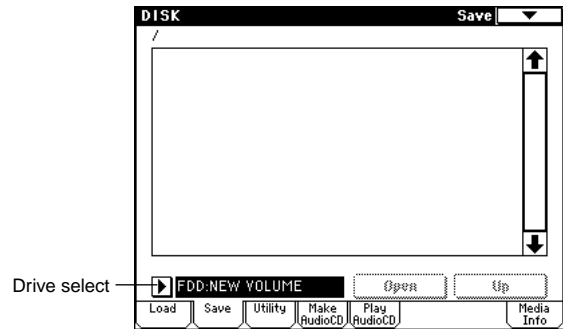

- ③ **Press the Save tab to access the Save page.**
- ④ **Press Drive Select to select the save-destination drive.**
- ⑤ **If the media contains directories, select the directory in which you want to save the data.**

To move to a lower level, press the **Open** button. To move to a higher level, press the **Up** button.

note If you are saving data on high-capacity media, we recommend that you create directories to organize the media into sections. To create a new directory, move to the level at which you want to create the directory, and execute the Utility page menu command "Create Directory."

- ⑥ **Press the page menu button to access the page menu, and press "Save All."**

Hide unknown file	Save to Std MIDI File
Translation	Save Exclusive
Save All	Export Smpl as AIF/WAV
Save PCG & SEQ	Save Audio CD Track List
Save PCG	
Save SEQ	
Save Sampling Data	

A dialog box will appear. The contents, settings, and operations for the dialog box will depend on the type of data that you are saving. For details refer to PG p.166.

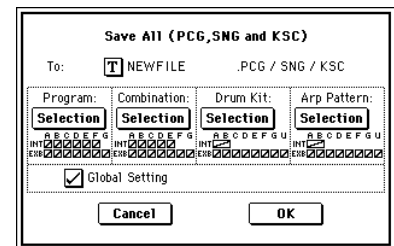

- ⑦ **Press the text edit button and input a filename for the file you want to save.** (PG p.40, 56)
- ⑧ **Press each Selection button to access the dialog box, and use the check boxes to uncheck any items that you do not need to save.**

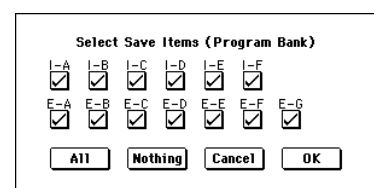

In order to accurately reproduce the data you created, we recommend that you check all of the boxes.

⑨ **Press the OK button to execute the Save operation.**

If the data fits on one volume of media

The data will be saved on the specified media, and you will return to the Save page.

If the data does not fit on one volume of media (floppy disk)

The “No space available on medium” dialog box will appear. (PG p.166)

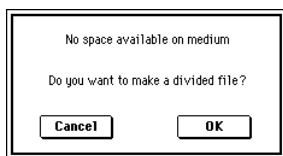

You can divide the file and save the data on multiple volumes of media. If you do not want to divide the data, press the Cancel button, and re-save the data on media that has more free area or on a different drive.

- 1) Make sure that you have a sufficient number of floppy disks, and press the OK button. Saving will begin.
- 2) When the disk is full, the following dialog box will appear.

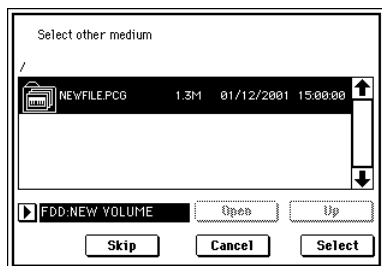

- 3) Insert the next floppy disk into the TRITON STUDIO's floppy disk drive.
- 4) Press a function key etc. to make the TRITON STUDIO detect the next floppy disk.
- 5) Press the Select button. Saving will begin.
- 6) If the “No Space available on medium” dialog box appears again, repeat steps 1)–5).

If you decide to cancel the Save operation, press the Cancel button.

The dialog box of step 2) will appear. Press the Cancel button again.

The display will ask “Are you sure?” Press the OK button. This will cancel the Save operation.

- 7) When saving is complete, you will return to the Save page.

⑩ **When saving ends and you return to the Save page, the LCD screen will show the file that was saved.**

The data will be saved to the media, and you will return to the Save page.

The amount of time required will depend on the amount of data.

If a file with the same name already exists on the floppy disk, you will be asked whether you want to overwrite. If you wish to overwrite, press the OK button. If you wish to save without overwriting, press the Cancel button, re-do the operation from step ⑥, and rename the data in step ⑦ before saving it.

The LCD screen will show the files that were saved.

The various types of data are saved as the following files.

.PCG file

Programs, combinations, user drum kits, user arpeggio patterns, and global settings that were saved in internal memory

.SNG file

Sequencer songs and cue lists

.KSC file

A file which lists the multisamples and samples used

Directory

A directory containing the multisamples (.KMP files) and samples (.KSF files) that are listed in the .KSC file

Other ways to save

In addition to “Save All,” the page menu commands include a “Save PCG” command which saves program, combination, drum kit, user arpeggio pattern, and global setting data, a “Save SEQ” command which saves only the sequencer song and cue list data, and a “Save Sampling Data” command which saves only the multisamples and samples (PG p.167). Select the page menu command that is appropriate for the data you want to save to external media.

note When using “Save All,” “Save PCG & SNG,” and “Save PCG” to save combinations, you should also remember to save the programs used by each timbre (and the drum kits used by the programs) and user arpeggio patterns at the same time.

Similarly when saving programs, you should also remember to save the drum kits and user arpeggio patterns used by the programs.

note If your programs or drum kits use multisamples and samples that were created in on TRITON STUDIO, we recommend that you use “Save All” to save the data.

When you use “Save PCG” or “Save Sampling Data” to individually save a program or drum kit, or a multisample or sample that you created, we recommend that you save them under the same filename in the same directory. When you use “Load PCG” to load a .PCG file, the identically-named .KSC file will also be loaded so that the correct multisamples/samples will correspond automatically.

Cautions when handling floppy disks

When handling floppy disks, please observe the following points. Data loss may occur if a floppy disk is handled improperly.

Floppy disk type and format

The TRITON STUDIO can use 2HD or 2DD 3.5 inch floppy disks.

Floppy disk handling

- Do not open the shutter of a floppy disk or touch the magnetic surface inside the disk. If the magnetic disk becomes soiled or scratched, it will no longer be possible to read the data.
- Never transport the TRITON STUDIO with a floppy disk in the disk drive. Vibration may cause the disk drive heads to scratch the floppy disk, making it unusable.
- Do not allow a floppy disk to be placed near a device that emits a magnetic field, such as a television, computer, computer display, speaker, or power supply transformer. This can erase data on the disk.
- Do not use or store floppy disks in locations of excessive temperature or humidity, in direct sunlight, or in dusty or dirty locations.
- Do not place objects on top of a floppy disk.
- While the disk drive is operating, do not attempt to remove the floppy disk, and do not subject the TRITON STUDIO to physical shock.

Floppy disk write protect

Floppy disks have a small write protect hole that can be used to prevent data from being erased or rewritten accidentally.

After saving data to disk, move the write protect tab so that the hole is uncovered. This will prohibit writing to the disk, and will prevent the data from being destroyed accidentally.

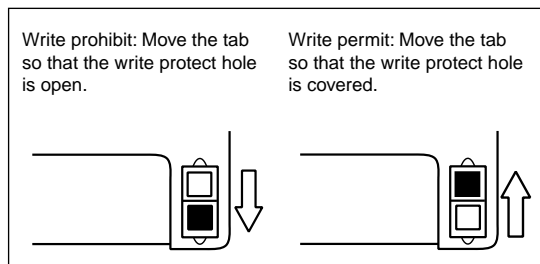

Inserting a floppy disk

With the label of the floppy disk facing upward, insert it into the disk drive. Press the disk inward until it clicks into place.

Malfunctions will occur if you use excessive force to insert the disk. Disks must be inserted gently, and straight in.

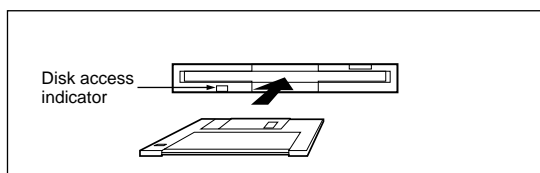

Removing a floppy disk

To remove a floppy disk, first make sure that the disk access indicator is dark. Then press the eject button and remove the disk.

If the disk does not come out when you press this button, do not attempt to remove the disk by force. Please contact your dealer.

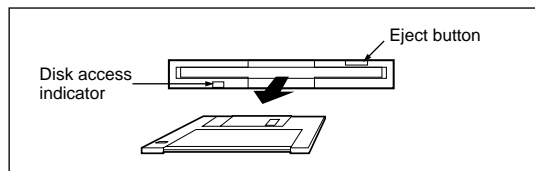

Head cleaning

If the heads of the disk drive are soiled, errors may occur during saving or loading. It is important to clean the heads regularly using a commercially available wet-type 3.5 inch double-sided head cleaning disk. For the cleaning procedure, refer to the owner's manual for your cleaning disk.

MIDI data dump

The programs (INT-A-INT-E, EXB-A-EXB-G), combinations (INT-A-INT-E, EXB-A-EXB-G), user drum kits, user arpeggio patterns and global settings of internal memory, and sequencer songs, cue lists, can be transmitted as MIDI exclusive data and saved on a connected MIDI data filer, computer, or another TRITON STUDIO. (PG p.145)

Loading data and restoring the factory settings

Loading data

Types of data that can be loaded

The types of data that can be loaded from media (floppy disk, etc.) are shown in the diagram below. (For details on each type of data, refer to PG p.155)

Loading data/Restoring the factory settings

When you want to use programs, combinations, samples, or songs that you saved, you will have to load them from media. You will also load data when you want to restore all programs, combinations, and other settings to the factory-set condition. In this case, you will load the PRELOAD.PCG file (contained in the included floppy disk and on the internal hard drive).

When loading programs, combinations, songs, user drum kits, or user arpeggio patterns, you must make sure that the Global mode memory protect setting is unchecked. (p.57)

The procedure for restoring the factory settings is described below. Here we will explain how to load the PRELOAD.PCG file from the included floppy disk.

A .PCG file contains programs, combinations, drum kits, user arpeggio patterns, and global settings.

When you load a .PCG file, the data in the TRITON STUDIO's internal memory will be overwritten by the data from the .PCG file (programs, combinations, drum kits, user arpeggio patterns, and global settings). If you want to keep the data that is currently in internal memory, you must first use "Save All" or "Save PCG" to save the current data.

1 Insert the "TNSFD-00P" floppy disk into the TRITON STUDIO's floppy disk drive.

For details on floppy disk handling, please be sure to read "Cautions when handling floppy disks" (p.62).

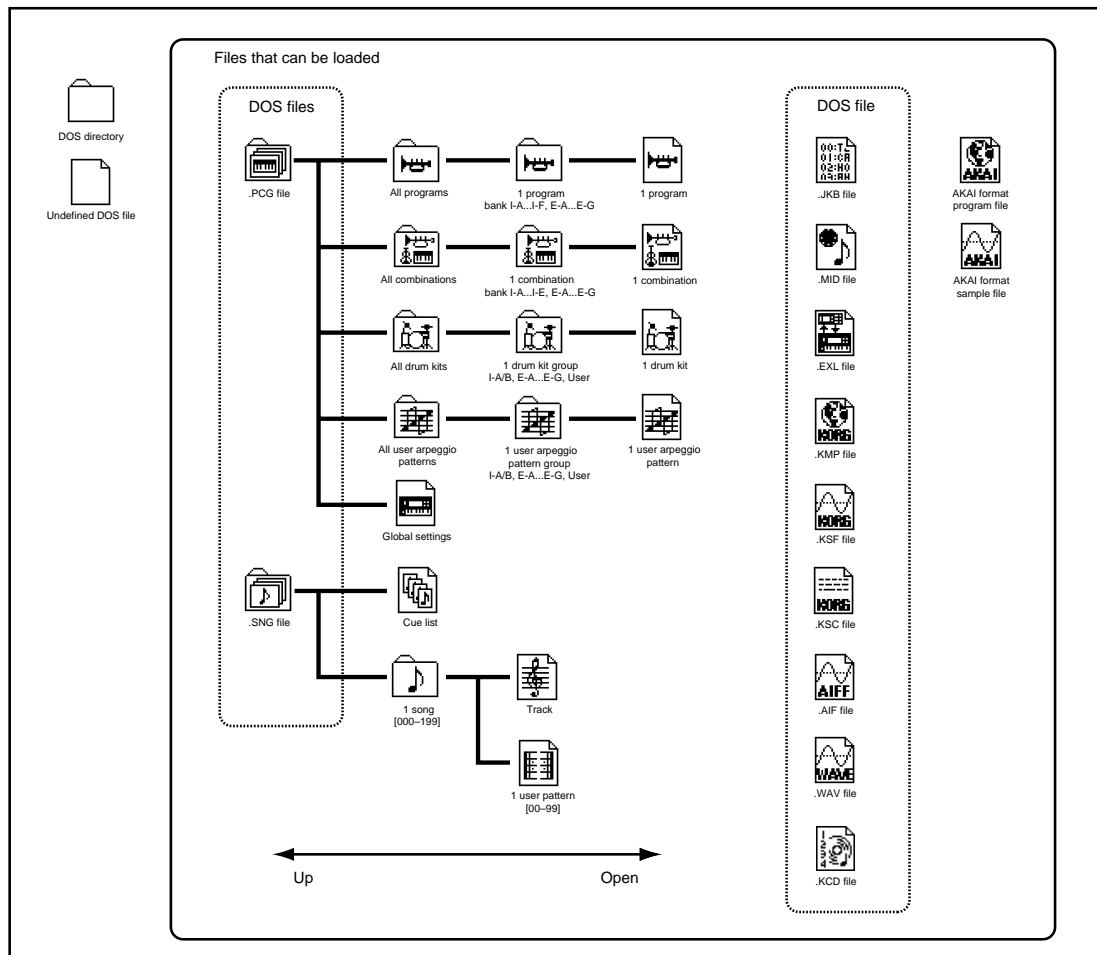

- ② Enter Disk mode, and touch the LCD screen to make the TRITON STUDIO detect the disk.

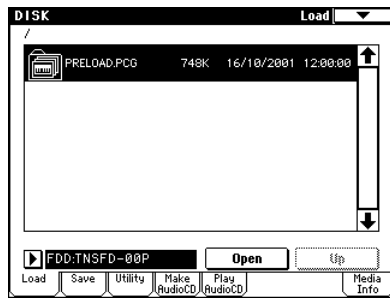

- ③ Press the Load tab to access the Load page.
The LCD screen will display file information.
- ④ Use "Drive select" to select the FDD.
- ⑤ Select the PRELOAD.PCG file.
The selected file will be highlighted.
- ⑥ Select the page menu command "Load Selected."

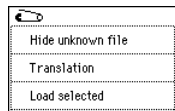

A dialog box will appear.

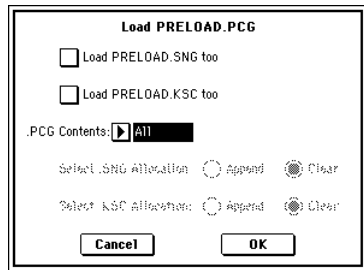

note The contents and settings of the dialog box will differ depending on the type of file that you are loading.

- ⑦ In ".PCG Contents," specify the data that you want to load.

If you want to load all data from the .PCG file, select All.

Since in this example we want to restore all settings to the factory-set condition, we will select All. If you load PRELOAD.PCG from the included floppy disk with All selected, all data of the .PCG file will be loaded as follows.

Programs

- Bank I-A file: loaded into bank INT-A
- Bank I-B file: loaded into bank INT-B
- Bank I-C file: loaded into bank INT-C
- Bank I-D file: loaded into bank INT-D
- Bank I-E file: loaded into bank INT-E

Combinations

- Bank I-A file: loaded into bank INT-A
- Bank I-B file: loaded into bank INT-B
- Bank I-C file: loaded into bank INT-C
- Bank I-D file: loaded into bank INT-D

Drum Kits

- 000-015 (I-A/B) file: loaded into bank I-A/B
- 128-143 (User) file: loaded into bank User

Arpeggio Patterns

- 000-199 (I-A/B) file: loaded into bank I-A/B
- 312-506 (User) file: loaded into bank User

- ⑧ Press the OK button to load the data.

Never remove the media while data is being loaded.

Loading individual banks from a .PCG file

In the dialog box for step ⑥ of "Loading data/Restoring the factory settings," it is also possible to set ".PCG Contents" to specify an individual bank to load, and set the "To" field to select the bank into which that data will be loaded.

When you execute loading, only the programs, combinations, drum kits, and user arpeggio pattern data of the selected bank will be loaded into the load-destination bank you specify. Global setting data will not be loaded.

If you set ".PCG Contents" to Bank I-A, and "To" to Bank I-A, data will be loaded as follows.

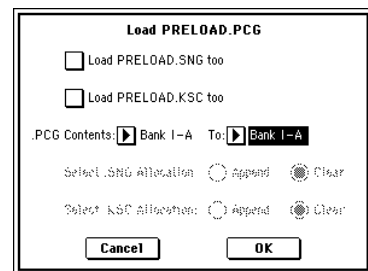

Programs

- Bank I-A file: loaded into bank INT-A

Combinations

- Bank I-A file: loaded into bank INT-A

Drum Kits

- 00-15 (I-A/B) file: loaded into bank I-A/B

Arpeggio Patterns

- 000-199 (I-A/B) file: loaded into bank I-A/B

When data is loaded into a bank that is different than its original bank, the data (bank, program, pattern, and kit numbers, etc.) will automatically be reconfigured so that after loading, the various types of data will correspond correctly in each mode.

The following data will also be reconfigured automatically if you have checked "Load .SNG too" (so that song data is loaded at the same time), in order to ensure that the song data plays back correctly.

- The bank of each program used by combinations
- The pattern number of each user arpeggio pattern used by the combinations/programs/songs
- The kit number of the drum kit used by each program
- The bank of the program used by each track of the song
- If the song contains track/pattern events, the program banks within these events

Loading data by individual item or bank

The TRITON STUDIO lets you load programs and combinations individually or by individual banks. Drum kits and arpeggio patterns can also be loaded individually or as a group.

This allows you to restore just an individual item to its factory setting, or to rearrange combinations (for example) in the order in which they will be played during a concert.

▲ Be aware that if you change the order of programs, the sounds played by combinations may also be affected. (☞p.149)

As an example, here's how to load the combination INT-D024: Rock Organ into INT-A000.

① From the "Bank I-A" directory, and select "Rock Organ." (PRELOAD.PCG/Combinations/Bank I-D/)

The procedure is as follows.

- 1) Perform steps ①-④ of the preceding procedure, press "PRELOAD.PCG" to highlight it, and press the Open button.
- 2) Press "Combinations" to highlight it, and press the Open button.
- 3) Press "Bank I-D" to highlight it, and press the Open button.
- 4) Press the scroll bar to find "Rock Organ," and press "Rock Organ" to highlight it.

Alternatively, you could select any file, since the desired file can be selected later from the dialog box.

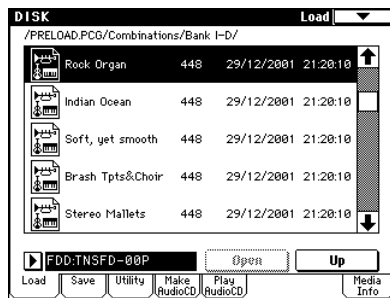

note When you press the keyboard of the TRITON STUDIO, the selected combination will sound. However, the internal programs will be used as the program of each timbre.

② Press the page menu button and select the "Load Selected" page menu command.

The dialog box will appear.



③ Use the "Combination" (upper line) to select the load-source combination, and use "(To) Combination" (lower line) to specify the destination combination. For this example, select A000: Combi I-A000.

④ Press the OK button to load the data. A000 will now be Rock Organ.

Contents of the included floppy disk

The TRITON STUDIO comes with one floppy disk (TNSFD-00P).

The disk contains the following data.

TNSFD-00P

PRELOAD.PCG (already loaded when the TRITON STUDIO is shipped)

- Programs (bank I-A, I-B, I-C, I-D, I-E)
- Combinations (bank I-A, I-B, I-C, I-D)
- Drum Kits (000-015 (I-A/B), 128-143 (User))
- Arpeggio Patterns (000-199 (I-A/B), 312-506 (User))

This is the preloaded data (programs, combinations, drum kits, arpeggio patterns, global settings).

••••• Loading .PCG files and .SNG files from the floppy disks included with the EXB-PCM series and EXB-MOSS options

The floppy disk included with each EXB-PCM series option and the EXB-MOSS option contains .PCG files and .SNG files that match the bank structure of the TRITON/TRITONpro/TRITONproX. (As of March 2002)

EXB-PCM series

EXB-PCM01-05

In each disk, C_BANK.PCG (.SNG) and D_BANK.PCG (.SNG) contain the same data, but use different banks.

EXB-PCM08

The data contained on the EXB-PCM08 is already included in the TRITON STUDIO's Piano PCM ROM.

EXB-PCM06/07

C_BANK.PCG and D_BANK.PCG contain different programs, combinations, drum kits, and arpeggio patterns.

When loading these TRITON/TRITONpro/TRITONproX format files from the EXB-PCM series disks into the TRITON STUDIO, you should load bank I-C of C_BANK.PCG or bank I-D of D_BANK.PCG, and not load banks I-A and I-B. We also recommend that you select EXB-A-EXB-G as the bank into which this data will be loaded.

Here is an example of how various files from the floppy disks included with the EXB-PCM01-07 can be loaded into banks EXB-A-EXB-G of the TRITON STUDIO.

- EXB-PCM01: file for bank C → load to bank EXB-A
- EXB-PCM02: file for bank C → load to bank EXB-B
- EXB-PCM03: file for bank C → load to bank EXB-C
- EXB-PCM04: file for bank C → load to bank EXB-D
- EXB-PCM05: file for bank C → load to bank EXB-E
- EXB-PCM06/07: file for bank C → load to bank EXB-F
- EXB-PCM06/07: file for bank D → load to bank EXB-G

note The loading destination banks need not be in the above order. Load the data into any bank (EXB-A-EXB-G) that will make it easy for you to keep your data organized.

▲ EXB-PCM boards can be installed in any slot 1-7. (☞PG p.286)

- ① **If you have modified the program settings or the order of the programs in banks INT-A or INT-B, load banks I-A and I-B from the internal hard disk or the included floppy disk.**

Combinations (except for those of the EXB-PCM03) are created using the EXB-PCM programs and the bank INT-A and INT-B preloaded programs. This means that when loading data (other than EXB-PCM03 data), you must load banks I-A and I-B of the preloaded programs. ("Loading data/Restoring the factory settings"  p.63)

- ② **Insert the included floppy disk, and select the .PCG file.**

For the EXB-PCM01-05:

As described in steps ①-⑤ of "Loading data/Restoring the factory settings," select **C_BANK.PCG**.

For the EXB-PCM06/07:

As described in steps ①-⑤ of "Loading data/Restoring the factory settings," select **C_BANK.PCG**.

After loading **C_BANK.PCG**, use the same procedure to select **D_BANK.PCG**. Load both files.

- ③ **Select the page menu command "Load Selected."**

A dialog box will appear.

- ④ **As described in "Loading individual banks of data from a .PCG file," set ".PCG Contents" and "To." Make the settings shown below.**

EXB-PCM01:

".PCG Contents": bank I-C, "To": bank E-A

EXB-PCM02:

".PCG Contents": bank I-C, "To": bank E-B

EXB-PCM03:

".PCG Contents": bank I-C, "To": bank E-C

"Load C_BANK.SNG too": On (checked)

".SNG Allocation": Clear

EXB-PCM04:

".PCG Contents": bank I-C, "To": bank E-D

"Load C_BANK.SNG too": On (checked)

".SNG Allocation": Append

EXB-PCM05:

".PCG Contents": bank I-C, "To": bank E-E

EXB-PCM06/07, C_BANK.PCG:

".PCG Contents": bank I-C, "To": bank E-F

EXB-PCM06/07, D_BANK.PCG:

".PCG Contents": bank I-D, "To": bank E-F

 **note** Because you checked "Load C_BANK.SNG too" for EXB-PCM03 and 04, the RPPR settings and patterns will be loaded into Sequencer mode. Because you set ".SNG Allocation" to Append for EXB-PCM04, the C_BANK.SNG (song data) that you had loaded for EXB-PCM03 will be preserved (i.e., not overwritten).

- ⑤ **Press the OK button to load the data.**

 If you execute with ".PCG Contents" set to **All**, the bank INT-A, INT-B, and INT-C (or INT-D) programs and combinations, all drum kits, all user arpeggio patterns, and global settings will be overwritten.

 If you want to keep the data that is currently in the internal memory, you must execute "Save All" or "Save PCG" to save the current data before you perform the procedure described here.

EXB-MOSS

If you want to load the floppy disk included with the EXB-MOSS into the TRITON STUDIO, load program bank I-F and combination bank I-B (000...063) from the MOSS.PCG file, and load the MOSS.SNG file. As described for the EXB-PCM series, you will not normally load bank I-A and I-B.

Program bank I-F should be loaded into bank INT-F, which is the program bank for the MOSS tone generator. We recommend that you select INT-E as the loading destination for combination bank I-B.

 The optional EXB-MOSS board must be installed. ( PG p.286)

- ① **If you have modified the program settings or the order of the programs in banks INT-A or INT-B, load banks I-A and I-B from the internal hard disk or the included floppy disk.**

The EXB-MOSS combinations are created using the EXB-MOSS programs and the bank INT-A and INT-B preloaded programs. This means that you must load banks I-A and I-B of the preloaded programs. ("Loading data/Restoring the factory settings"  p.63)

- ② **Insert the included floppy disk, and select the program bank I-F and combination bank I-B file.**

Selecting program bank I-F:

Select **MOSS.PCG** as described in steps ①-⑤ of "Loading data/Restoring the factory settings." Press the Open button to select the Programs folder, and press the Open button once again to select the bank I-F folder.

Selecting combination bank I-B:

Select **MOSS.PCG** as described in steps ①-⑤ of "Loading data/Restoring the factory settings." Press the Open button to select the Combinations folder, and press the Open button once again to select the bank I-B folder.

- ③ **Select the page menu command "Load Selected" to load the data.**

If **program bank I-F** is selected, the Load Program Bank F dialog box will appear. Press the **OK button** to load the data.

If **combination bank I-B** is selected, the Load Combination Bank I-B will appear. Set "**To**" to **Bank I-E**, and press the **OK button** to load the data.

 If you want to keep the data that is currently in the internal memory area, use "Save All" or "Save PCG" to save the current data before you perform the procedure described here.

To load the demo song data for the MOSS tone generator, select **MOSS.SNG**, and use "Load Selected" to load it. For details on "Select SNG Allocation," refer to the note at the end of step ④ of the preceding section.

Program settings

Program editing is performed in Program mode, just as programs can be selected and played in Program mode.

Program mode consists of the P0: Play–P9: Edit-Master Effect pages.

In P0: Play, you can select and play programs. You can also perform simple editing of the program, make arpeggiator settings, and make settings for audio input and sampling. (p.22, 34, 45)

In P1: Edit-Basic–P9: Edit-Master Effect, you can edit the parameters of the program you selected in P0: Play. When shipped, the TRITON STUDIO contains numerous preloaded programs. You can edit the settings of these preloaded programs to create your own original programs. You can also create original programs that use sampled waveforms and multisamples that you sampled on the TRITON STUDIO or loaded into the internal sample memory (RAM) in Disk mode.

note You can perform sampling/resampling in Program mode (p.45). You can also apply the TRITON STUDIO's effects to an external audio input, for a wide range of possibilities. (p.143)

note All transmission and reception of MIDI data in Program mode is performed on the global MIDI channel. The global MIDI channel is set in Global P1: MIDI "MIDI Channel."

How a program is organized

A program consists of the many parameters of P1: Edit-Basic–P9: Edit-Master Effect. The diagram below shows the structure of a program.

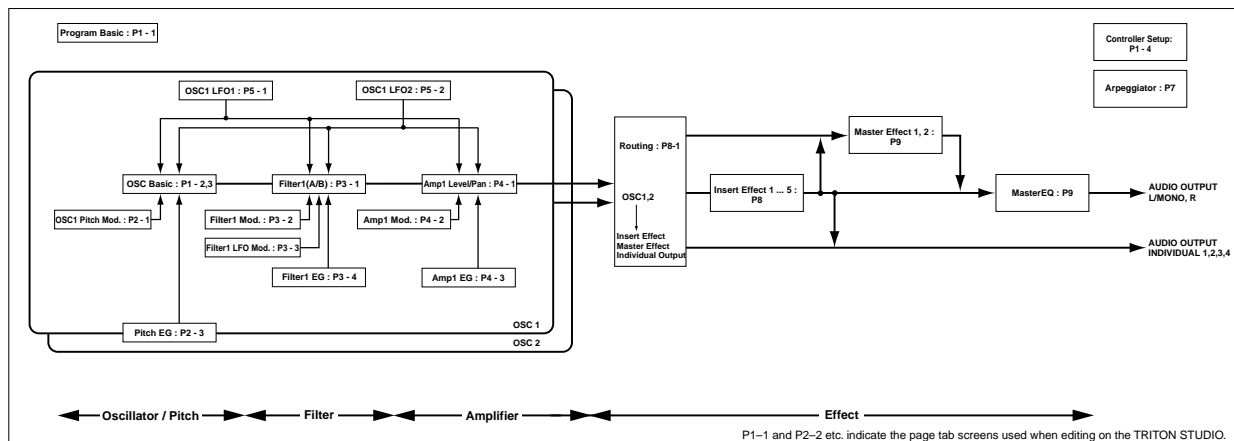

Basic program editing

You can edit the preloaded programs (banks INT-A–INT-D) that the TRITON STUDIO is shipped with, or you can start with an initialized program (banks INT-E, EXB-A–EXB-G) to create an original program.

note The P1: Edit-Basic–P5: Edit-Common LFO parameters, which are set independently for oscillators 1 and 2, can be copied using the page menu command "Copy Oscillator." This is useful when you want to make the same settings for both oscillators, or when you want to copy settings from another program.

! If you wish to save an edited program into internal memory, be sure to Write the program. (p.56)

In this section we will give examples of how to modify representative parameters in each page.

For details on all parameters, refer to in the PG p.1-.

Programs you edit or create can be written into the 1,536 program memory areas of banks INT-A–INT-E, EXB-A–EXB-G.

You can also save and manage programs on various types of media. (p.59)

note If the EXB-MOSS option is installed, you will be able to use the special bank INT-F. The parameter structure of bank INT-F programs is different than that of the other banks. Refer to the EXB-MOSS owner's manual.

The three elements of sound

Sound can be broken down into three elements: **pitch**, **tone**, and **volume**.

On TRITON STUDIO, these elements correspond to the **Pitch**, **Filter**, and **Amplifier** settings of a program. In other words you would adjust the Pitch settings to modify the pitch, the Filter settings to modify the tone, and the Amplifier settings to modify the volume.

In **Oscillator (Oscillator: P1: Edit-Basic settings)** you select the waveform **multisample** that determines the basic sound, and specify its pitch. This sound is then modified by the **pitch** settings (**Pitch: P2: Edit-Pitch**), **filter** settings (**Filter: P3: Edit-Filter**), and **amp** settings (**Amplifier: P4: Edit-Amp**) to create the basic sound of the program.

This basic sound can then be modified further by using the **insert effects** (P8: Edit-Insert Effect settings), **master effects**, and **master EQ** (P9: Edit-Master Effect settings) to apply finishing touches.

When **arpeggiator** settings (P7: Edit-Arpeggiator.) and controller settings (P1: Edit: Basic) are added to this, the final result is called a “program.”

note A program that is used in the Combination, Sequencer or Song Play modes will have insert effect, master effect, master EQ, arpeggiator, and controller settings that are separate from those it has in the Program mode.

The Compare function

When P1–P9 are selected, pressing the [COMPARE] key (the LED will light) will recall the sound that was written before you edited it.

Pressing [COMPARE] again (the light goes dark) returns you to the version you are editing.

note If you edit while the [COMPARE] key LED is lit, the key will go dark. That previous sound will now become be the sound that is recalled when the [COMPARE] key LED is dark.

Oscillator settings

P1: Edit-Basic

Basic settings for the oscillator are made in the P1: Edit-Basic page. The TRITON STUDIO provides two oscillators, and for each oscillator you can select a basic waveform (“**multisample**”) and set the pitch.

The multisamples provided by the TRITON STUDIO include waveforms for musical instruments such as pianos, as well as special waveforms unique to synthesizers. Multisamples reproduce the complex overtone structure and frequency characteristics that allow us to identify a sound as being “piano-like” or “guitar-like” etc...

Program Basic page

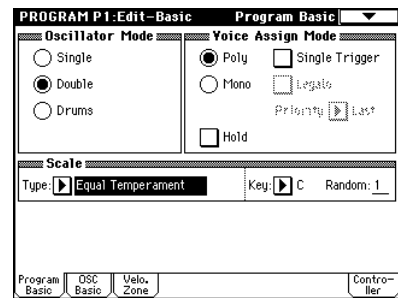

Oscillator Mode

This sets the mode of the oscillator. **Single** uses one oscillator and **Double** uses two oscillators. In the case of **Single** the maximum polyphony is **60 notes**, and in the case of **Double** the maximum polyphony is **30 notes**. If you wish to use a Drum Kit to create a drums program, select **Drums**. In the case of Drums, the polyphony is normally **60 notes**.

note Depending on the multisamples that are selected for each oscillator, the maximum polyphony can be up to **120 notes** for **Single**, up to **60 notes** for **Double**, and up to **120 notes** for **Drums**. (see p.15)

Voice Assign Mode

Select whether the program will sound in **Poly** (polyphonically) or **Mono** (monophonically). If this is set to **Poly**, you will be able to play chords using the program. If this is set to **Mono**, only one note will sound even if you play a chord. Normally you will set this to **Poly**, but it is effective to use **Mono** when you are playing sounds such as a solo instrument, an analog-synth bass or a synth lead. Try switching between Poly and Mono, and listen to the results.

OSC Basic page

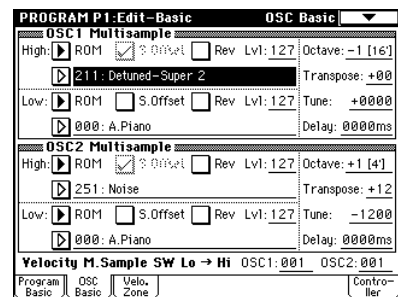

In this page you can select the multisample for each oscillator. The TRITON STUDIO provides 429 multisamples in its internal ROM memory (see VNL).

Additional multisamples can be added by installing EXB-PCM series options. Data sampled on the TRITON STUDIO can also be used as a multisample.

Selecting a multisample

The multisample will determine the basic character of the program.

- Use “**High MS Bank**” to select the multisample bank, and use “**High Multisample**” to select the multisample.

If the “**High MS Bank**” is **ROM**, you can select preset multisamples. “High Multisample” can be selected from a range of 000–424. (≡VNL)

If “**High MS Bank**” is **RAM**, you can select multisamples that were sampled on the TRITON STUDIO or loaded in from media. Select from 000–999 for “High multisample.”

If “**High MS Bank**” is **Piano**, you can select one of the large preset piano multisamples. Select from 000–003 for “High Multisample.”

- note** If “**High MS Bank**” is set to **ROM**, pressing the “**High Multisample**” popup button will display all internal ROM multisamples, organized into 15 categories. Use the tabs located at the left and right to select the desired category, and select a multisample from within that category.

High Multisample and Low Multisample

If you specify a *High* and *Low* multisample for an oscillator, either the High or the Low multisample will sound depending on the velocity of the note (i.e., the strength at which you play the keyboard). This function is called **velocity multisample switching**.

- ① Specify different multisamples for “**High Multisample**” and “**Low Multisample**.”
- ② Specify a velocity value for “**Velocity M.Sample SW Lo→Hi**.”

Notes played on the keyboard at a velocity less than the value you specify will sound the Low multisample; velocities at or above this velocity value will sound the High multisample.

For example if you set “**Velocity M.Sample SW Lo→Hi**” to 100, playing the keyboard softly will sound the “Low multisample,” and playing strongly will sound the “High multisample.”

- ③ Adjust the “**Lvl**” (Level) for *High* and *Low* multisamples to set their volume balance.

If you do not wish to use this function, set the “**Velocity M.Sample SW Lo→Hi**” value to 001. Only the *High* multisample will sound.

Rev (Reverse) check box

If this is **checked**, the multisample will be played backward. This can produce interesting results when used on sound-effects, etc. Normally you will not check this.

When “Oscillator Mode” = Double

To use OSC2, set “**Oscillator Mode**” to **Double** in the Program Basic page.

In the same way as for OSC1, you can set *High* and *Low* multisamples for OSC2.

The playback pitch can be set independently. By using the same multisample with slightly different “Tune” settings, you can “detune” the oscillators to produce a richer sound.

- note** It will be convenient to use the page menu command “Copy Oscillator” to make the oscillator settings match each other.

When “Oscillator Mode” = Drums

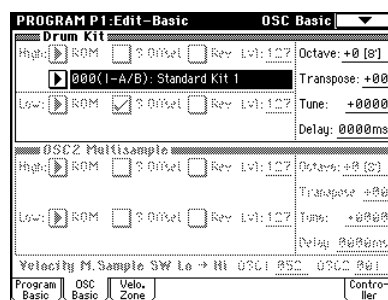

In the Program Basic page, set “**Oscillator Mode**” to **Drums**. When this is set to **Drums**, you will be able to create a drum program.

This will select a drum kit instead of a multisample. TRITON STUDIO provides twenty factory preset drum kits that are suitable for a wide variety of music. (≡VNL) Here you can only select a drum kit. To edit or create a drum kit, use Global P5: Drum Kit (≡p.128).

The following multisamples or drum kits can be used for the oscillator.

- 425 internal multisamples (ROM)
- Multisamples that you sampled (RAM) (Programs can be created from multisamples/samples that you sampled in Sampling mode etc. or loaded from media in Disk mode.)
- Four internal piano multisamples (Piano)
- Expansion multisamples (if a EXB-PCM option is installed)
- Nine internal drum kits (ROM)
- 144 user drum kits created in Global mode (Drum samples can be freely assigned to each key to create a drum kit. For the sound of each key, you can make filter and amp settings, and specify routing to the effects and to the individual audio outputs.)

Velocity Zone page

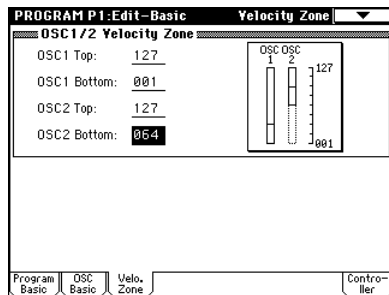

Here you can specify the range of velocities for each oscillator. In the example shown above, the velocity ranges are as follows.

- OSC1 will sound at all velocity values.
- OSC2 will sound only on strongly played notes (64 and above).
- You can use Velocity Multisample Switching in addition to this parameter (☞ “High Multisample, Low Multisample”). For this example, set “OSC1” in “Velocity M.Sample SW Lo→Hi” to **32** and “OSC2” to **096**. The settings are shown as vertical lines in the velocity zone display.

In this example, the multisamples will sound over four levels.

- Velocity values 001–031: sounds only the OSC1 Low multisample.
- Velocity values 032–063: sounds only the OSC1 High multisample.
- Velocity values 064–095: sounds the OSC1 High multisample and the OSC2 Low multisample.
- Velocity values 096–127: sounds the OSC1 High multisample and the OSC2 High multisample.

Controller Setup page

For each program, this tab lets you make settings for the [SW1] and [SW2] key, and for the B-mode of REALTIME CONTROLS knobs [1]–[4] (☞ p.145, PG p.12, 249, 250)

Pitch settings

P2: Edit-Pitch

Here you can specify how the pitch of the multisample assigned to each oscillator will change. Pitch EG and LFO settings allow the pitch to varied over time. The OSC1 P.Mod page is valid when “Oscillator Mode” is set to **Single** or **Drums**.

OSC1 Pitch Mod. page

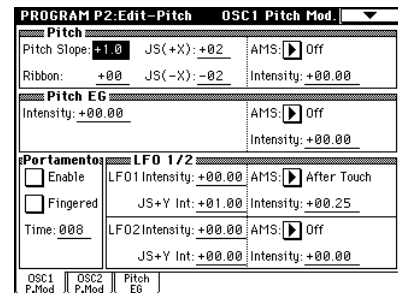

Pitch

The “**JS (-X)**” and “**JS(+X)**” settings specify the amount of pitch change (in semitones) that will occur when MIDI pitch bend messages are received or when the joystick is moved to left or right. A setting of **+12** allows the pitch to be controlled a maximum of one octave upward; a setting of **-12** allows the pitch to be controlled a maximum of one octave downward.

“**Ribbon**” specifies the amount of pitch change (in semitones) that will occur when MIDI control change (CC) #16 messages are received or when the ribbon controller of a TRITON STUDIO or other MIDI-connected instrument is moved to left or right. With a setting of **+12**, the pitch will be raised one octave at the far right of the ribbon controller, and will be lowered by one octave at the far left of the ribbon controller.

Pitch EG

When the “**Intensity**” value is set to **+12.00**, the pitch EG specified in the Pitch EG page will produce a maximum of ± 1 octave of pitch change.

Portamento

If “**Enable**” is checked, portamento will be applied. Portamento makes the pitch change smoothly when you play the next note before releasing the previous note. The “**Time**” parameter specifies the portamento time. As this value is increased, the pitch will change over a longer time. With a value of **000**, there will be no portamento.

note If **Porta.SW CC#65** is assigned as the function of [SW1] or [SW2] key, the portamento effect can be switched on/off by [SW1] or [SW2] key.

LFO 1/2

An LFO can be used to cyclically modulate the pitch (a “**vibrato**” effect).

“**LFO 1/2 Intensity**” sets the depth to which the LFO specified in P5: Edit-Common LFO will affect the pitch. With a setting of **+12.00**, vibrato will produce a maximum of ± 1 octave of pitch change.

“**JS+Y Int**” specifies the amount of vibrato that the LFO will produce when the joystick is pushed away from yourself.

“**Intensity** (AMS Intensity)” specifies the depth of vibrato that will be applied by the LFO when an AMS (Alternate Modulation Source) is used. For example if “AMS (LFO1 AMS)” is set to **After Touch** and you set an appropriate value for “**Intensity** (AMS Intensity),” vibrato will be applied when you apply pressure to the keyboard or when MIDI aftertouch messages are received.

Pitch EG page

Here you can adjust the settings for the pitch EG. When you wish to create sound effects etc., set the pitch EG to make major changes in pitch over time. To realistically simulate the slight change in pitch that occurs when a string is plucked or at the attack of a brass or vocal sound, you can use the EG to create a subtle change in pitch at the attack (PG p.12).

EG and LFO

By using an EG (envelope generator) to apply time-varying change or by using an LFO (Low Frequency Oscillator) to apply cyclic change to pitch, filter, or amp, you can create changes in the pitch, tone, or volume.

EG (Envelope Generator)

TRITON STUDIO provides a Pitch EG, Filter EG, and Amplifier EG, which produce time-varying changes in pitch, tone, and volume respectively.

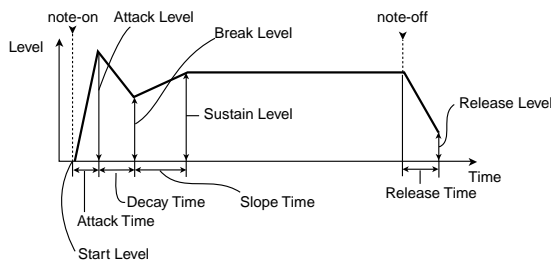

LFO (Low Frequency Oscillator)

For each oscillator, TRITON STUDIO provides two LFO's that can be used to apply cyclical change in pitch, tone, and volume.

Examples of this are vibrato (cyclical change in pitch), wah (cyclical change in tone), and tremolo or auto-pan (cyclical change in volume).

Filter settings P3: Edit-Filter

The filter allows you to diminish or emphasize specified frequency areas of the multisample selected for the oscillator.

The tone of the sound will depend significantly on the filter settings.

TRITON STUDIO provides Filter 1 for OSC1 and Filter 2 for OSC2. For each of these filters, you can select from two types (**Low Pass Resonance** or **Low Pass & High Pass**). Filter 2 can be used if “**Oscillator Mode**” is set to **Double**.

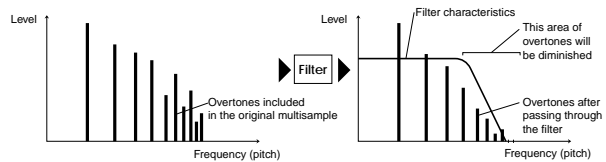

Filter1 page

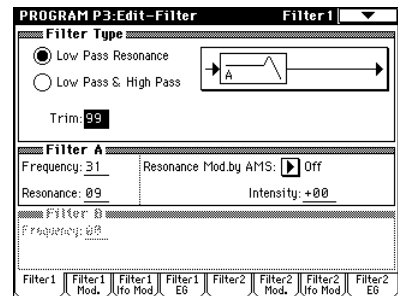

Filter Type, Filter A, Filter B

Selects the type of filter, and specify the “**Frequency**” (cut-off frequency) and “**Resonance**” (resonance level).

- **Low Pass Resonance** (24 dB/oct low pass filter with resonance): Make settings for filter A.
- **Low Pass & High Pass** (12 dB/oct low pass filter and 12 dB/oct high pass filter in series connection): Make low pass filter settings in filter A, and high pass filter settings in filter B.

Low pass filter

This is the most common type of filter, which allows the low frequency range to pass and cuts the high frequency range. When the overtones of the high range are cut, a bright sound will become darker (more mellow).

24 dB/oct and 12 dB/oct refer to the steepness of the cut. 24 dB/oct means that the gain will decrease 24 dB in one octave (i.e., as the frequency doubles). A 12 dB/oct filter would decrease the gain 12 dB in one octave. The 24 dB/oct filter produces a steeper cut.

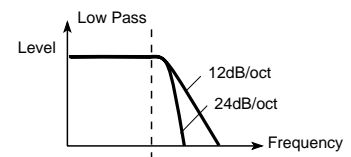

High pass filter

This type of filter allows the high frequency range to pass and cuts the low frequency range. Use this when you wish to make the sound thinner. However if the cutoff frequency (Frequency) is raised excessively high, the volume will become very low.

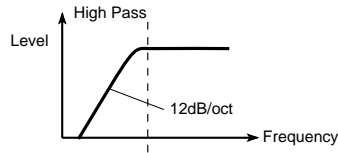

Resonance

When “**Resonance**” is set to a higher value, the overtones in the region of the cutoff frequency will be boosted as shown in the diagram below, giving a distinctive character to the sound.

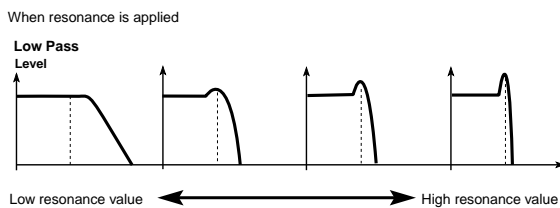

Filter1 Mod. page

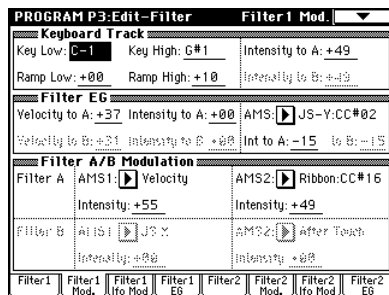

Controllers and the filter EG can be used to modulate the filter cutoff frequency that was specified in the Filter1 page. By using a controller to vary the tone or by using an EG to create time-varying changes, you can add a rich variety of tonal change to the sound.

Keyboard Track

This varies the cutoff frequency according to the position of the key on the keyboard that you play.

- When “**Ramp Low**” is set to a positive (+) value, the cutoff frequency will rise as you play lower on the keyboard, making the sound brighter. When set to a negative (-) value, the cutoff frequency will fall as you play lower on the keyboard, making the sound darker.
- When “**Ramp High**” is set to a positive (+) value, the cutoff frequency will rise as you play higher on the keyboard, making the sound brighter. When set to a negative (-) value, the cutoff frequency will fall as you play higher on the keyboard, making the sound darker.
- “**Intensity to A**” and “**Intensity to B**” adjust the effect that keyboard tracking will have on filters A and B (PG p.17).

Filter EG

Adjusts the effect produced by the filter EG, whose settings are made in the EG page.

- Use the “**Velocity to A**” and “**Velocity to B**” settings to specify the effect of velocity on the filter EG.
- Use the “**Intensity to A**” and “**Intensity to B**” settings to specify the depth of the filter EG.
- “**Into A (AMS Int. to A)**” and “**Into B (AMS Int. to A)**” adjust the effect that AMS will have on the filter EG depth. These three settings will determine the depth of the tonal change produced by the filter EG.

Filter A/B Modulation

Set this when you wish to produce tonal change by using controllers etc. to vary the cutoff frequency.

Filter1 LFO Mod. page

Indicates settings that allow the LFO to produce cyclic changes in tone (a “wah” effect).

“**Intensity to A (LFO Int. to A)**” and “**Intensity to B (LFO Int. to B)**” specify by how much the LFO will change the tone.

“**JS-Y Intensity to A**” and “**JS-Y Intensity to B**” specify the depth of the wah effect that will be produced by the LFO when the joystick of TRITON STUDIO is moved toward yourself, or when CC#2 is received.

“**Intensity to A (LFO1 AMS Int.to A)**” and “**Intensity to B (LFO1 AMS Int. to B)**” specify the depth of the wah effect that will be produced by the LFO when “**AMS (LFO1 AMS)**” is used. For example if “**AMS (LFO1 AMS)**” is set to **After Touch**, applying pressure to the keyboard of the TRITON STUDIO, will produce a wah effect.

Filter1 EG page

Indicates settings for the filter EG, which controls time-variant changes in tone. Make settings for the EG here, and set the depth of its effect in the Filter1 Mod. page *Filter EG* parameter (PG p.19).

Filter EG and Amplifier EG

When the Filter EG changes the cutoff frequency, the tone will change. However depending on the volume changes produced by the Amplifier EG, this can be heard in different ways. For example by changing the speed at which the tone and volume begin (attack) or decay, you can significantly vary the character of the tonal change. It is a good idea to adjust the changes of both the Filter EG (tone) and the Amplifier EG (volume) as you proceed with editing. (PG p.19)

Amplifier settings P4: Edit-Amp

These settings affect the volume. Here you can adjust the way in which the Amp EG and LFO produce time-varying and cyclic changes in volume, and how the controllers etc. will affect the volume.

Amp1 applies to OSC1, and Amp2 applies to OSC2.

Amp2 can be used if “**Oscillator Mode**” is set to **Double**.

For example, the volume of a piano note begins at a high volume the instant you play the note, and then decreases gradually. The volume of an organ note remains constant as long as you continue pressing the key. The volume of a note on a violin or wind instrument can be varied during the note by the musician (i.e., by regulating the amount of pressure on the bow or the force of the breath).

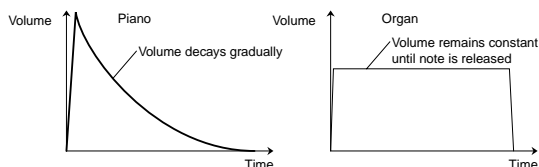

Amp1 Level/Pan page

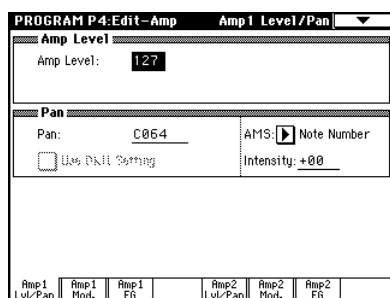

Amp Level

Adjusts the volume of the sound that has passed through the oscillator, filter, and amp.

Pan

Specifies the pan (stereo position) after the signal has passed through the oscillator, filter, and amp. Normally you will set this to **C064**. If “**Oscillator Mode**” is **Double** and you wish to create a sense of stereo, set the Amp1 Level/Pan page and Amp2 Level/Pan page parameter “**Pan**” to left and right for oscillators 1 and 2 respectively. With a setting of **Random**, the pan will change randomly each time you play a note on TRITON STUDIO, producing an interesting effect.

AMS (Pan AMS), Intensity

“**Intensity**” specifies the depth of the panning effect that will occur when “**AMS (Pan AMS)**” is in use.

If you set “**AMS (Pan AMS)**” to **Note Number**, the pan will change according to the keyboard position at which you play a note on a TRITON STUDIO. With a setting of **LFO1** or **2**, the sound will sweep from side to side (auto pan). Other settings allow you to move the oscillator pan by operating a controller.

Use DKit Setting

This is valid when “**Oscillator Mode**” is set to **Drums**. If this is **checked**, the pan location specified by the Drum Kit for each drum sound will be used. If this is **unchecked**, all drum sounds will sound at the same location. Preload and GM drum kits are set to stereo settings. Normally you will leave this **checked**.

Amp Mod. page

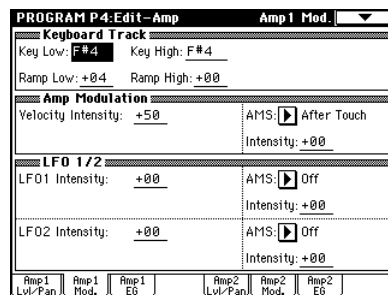

Keyboard Track

This lets you vary the volume relative to the position of the key you are playing on the keyboard.

- When “**Ramp Low**” has a positive (+) value, the volume will increase as you play lower on the keyboard. With a negative (-) value, the volume will decrease as you play lower on the keyboard.
- When “**Ramp High**” has a positive (+) value, the volume will increase as you play higher on the keyboard. With a negative (-) value, the volume will decrease as you play higher on the keyboard.

Amp Modulation

“**Velocity Intensity**” is used by most programs to decrease the volume of softly played notes and increase the volume of strongly played notes, and the Amp Modulation parameter adjusts the depth of this control. Normally you will set Amp Modulation to positive (+) values. As this setting is increased, there will be greater volume difference between softly played and strongly played notes.

LFO1/2

Specifies how the LFO’s will produce cyclic changes in volume (tremolo effect).

The volume will be affected by the LFO(s) for which you set an “**LFO1 Intensity**”, “**LFO2 Intensity**” value.

“**Intensity (AMS Intensity)**” adjusts the depth by which the tremolo effect produced by the LFO will be affected when you assign an “**AMS (LFO1 AMS, LFO2 AMS)**.” For example if you set “**AMS**” to **JS-Y: #02**, tremolo will be applied when you move the joystick of TRITON STUDIO toward yourself, or when **CC#02** is received.

Amp1 EG page

Here you can make settings for the amp EG, which changes the volume over time.

Every instrument has its own characteristic curve of volume change. This is part of what gives each instrument its identifiable character. Conversely, by applying a strings-type Amp EG curve to an organ-type multisample, you can produce a sound with a character unlike a typical organ.

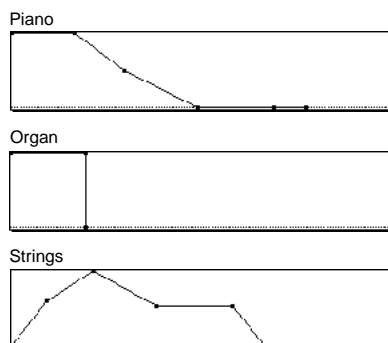

LFO settings P5: Edit-Common LFO

For each oscillator, you can use two LFO (Low Frequency Oscillator) units: LFO1 and LFO2. You are free to select the type of each LFO and set its speed.

The depth of the LFO1 and LFO2 that you specify here is adjusted by the settings of the P2: Edit-Pitch, P3: Edit-Filter and P4: Edit-Amp pages.

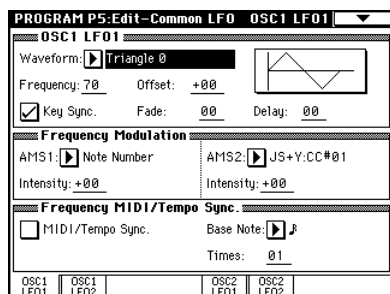

OSC1 LFO1, OSC1 LFO2, OSC2 LFO1, OSC2 LFO2

“**Waveform**” selects the type of LFO. You can choose from a variety of waveforms, including standard waveforms such as **Triangle**, **Saw**, **Square**, and **Sine**, as well as **Step** or **Random PG** waveforms that produce a sample-and-hold effect (see PG p.25).

You can create a wide variety of effects by adjusting the “**Offset**,” “**Fade**,” and “**Delay**” settings, and by changing the sign (+/-) of the “**Intensity**” setting in the P2: Edit-Pitch, P3: Edit-Filter and P4: Edit-Amp pages. “**Frequency**” specifies the speed of the LFO.

Frequency Modulation

“**AMS**” can be used to vary the LFO speed. This lets you change the LFO speed by operating a controller, or by the EG or Keyboard Track settings.

Frequency MIDI/Tempo Sync.

If “**MIDI/Tempo Sync**” is checked, the “**Frequency**” setting will be ignored, and the LFO will synchronize to the tempo of the sequencer and arpeggiator. This lets you produce vibrato, wah, auto-pan, or tremolo effects that are synchronized to the playback speed of the sequencer or arpeggiator.

Arpeggiator settings

P7: Edit-Arpeggiator

Here you can make arpeggiator settings (see p.130).

Insert Effect settings

P8: Edit-Insert Effect

Here you can select insert effects and make settings for them. You can also specify the oscillator routing (the signal sent to the insert effects, master effects, and independent outputs) (see p.140).

Master Effect settings

P9: Edit-Master Effect

Here you can select master effects and make settings for them. The master EQ is also set here (see p.141).

More about Alternate Modulation

Alternate Modulation is a type of modulation that can be used to control various aspects of the sound.

AMS (Alternate Modulation Source) refers to any of the numerous sources that can provide alternate modulation, and includes controllers that you operate physically such as the joystick and realtime controllers, incoming MIDI data, as well as modulators such as the EG or LFO. Since TRITON STUDIO allows you to apply modulation to a modulator, this type of control is referred to as “alternate modulation.”

Intensity is a parameter that sets the degree (speed or depth) to which AMS will control alternate modulation.

Combinations of modulations that are frequently used in synthesizer performance (such as using the joystick to vary the pitch) are also provided as special parameters separate from alternate modulation.

TRITON STUDIO provides 29 types of alternate modulation.

In single mode you can use 29 alternate modulation destinations of 29 types, and in double mode you can use 55 alternate modulation destinations of 29 types.

There are 42 AMS sources. (However depending on the type of modulation, some sources cannot be selected.)

For details on alternate modulation and AMS, refer to PG p.241.

Suggestions on using alternate modulation

When making settings for alternate modulation, think of the effect that you wish to produce, what type of modulation will be necessary to produce that effect, and what parameter of the oscillator, filter, or amplifier needs to be controlled. Then select a source (“**AMS**”) and set the “**Intensity**.” If you proceed logically in this way, you will achieve the desired effect.

For example if you want to “control a guitar-like sound so that it appears to be approaching feedback when the joystick is moved away,” you will make settings so that the joystick controls filter modulation or the resonance level.

Combination settings

Combination editing is performed in Combination mode, just as combinations can be selected and played in Combination mode.

Combination mode consists of the P0: Play–P9: Edit-Master FX pages.

In P0: Play, you can select and play combinations. You can also perform simple editing, make arpeggiator settings, and make settings for audio input and sampling. (☞p.24, 31, 35)

In P1: Edit-Program/Mixer–P9: Edit-Master FX, you can edit the parameters of the combination you selected in P0: Play.

note You can perform sampling/resampling in Combination mode (☞p.45, 102). You can also apply the TRITON STUDIO's effects to an external audio input, for a wide range of possibilities. (☞p.143)

How a combination is organized

A combination consists of a variety of parameters that can be accessed in P1: Edit-Program/Mixer–P9: Edit-Master FX. The diagram below shows how a combination is structured.

Basic combination editing

You can edit the preloaded combinations (banks INT-A–INT-D) with which the TRITON STUDIO is shipped, or start with an initialized combination (banks INT-E, EXB-A–EXB-G) to create your own original combination.

note Original programs using sample waveforms/multi-samples you sampled on the TRITON STUDIO (or loaded into memory via Disk mode) can also be used in a combination.

note If you wish to save an edited combination in internal memory, you must write it. (☞p.56)

note If a program being edited in Program mode is used in a combination, it will sound according to the settings being edited.

In the following pages, we will explain how to edit some of the major parameters, and explain their functions.

For a more detailed explanation of the parameters, refer to PG p.33 and following.

Combinations that you edit or create from scratch can be written into the 1,536 combination memory areas (internal memory) of banks INT-A–INT-E and EXB-A–EXB-G. They can also be stored and managed on various types of media. (☞p.59)

Suggestions for editing procedure

The parameters of each timbre are set in P1: Edit-Program/Mixer–P9: Edit-Master FX. This is where you create the basic combination consisting of the programs you select here.

First use P1: Edit-Program/Mixer to select the program for each timbre, and then use P4: Edit-Zone/Ctrl to specify the range in which each program will sound (layer, split, velocity switch, etc.). Then adjust the volume of each timbre, and set various other parameters.

To add finishing touches to the sound, you can assign insert effect settings (in P8: Edit-Insert FX) and master effect and master EQ settings (in P9: Edit-Master FX) that are different from the effect settings of Program mode. In addition, you can make arpeggiator settings (in P7: Edit-Arp.) and controller settings (in P4: Edit-Zone/Ctrl) to create the finished combination.

note By using the page menu command “Solo Selected Timbre”, you can listen only to the selected timbre. This is a convenient way to audition individual sounds of timbres that are layered. (☞PG p.35)

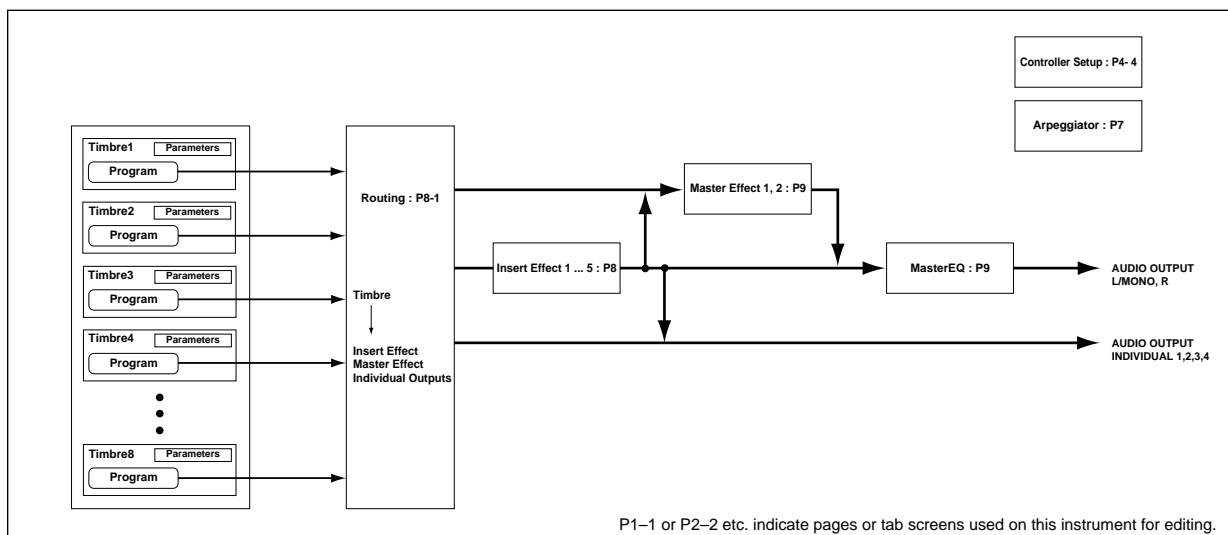

P1–1 or P2–2 etc. indicate pages or tab screens used on this instrument for editing.

Layer, split, and velocity switch

Within a combination, you can use key position and velocity to determine which program will sound.

The programs assigned to each timbre can sound in three ways: as part of a **layer**, a **split**, or a **velocity switch**. A combination can be set to use any one of these methods, or to use two or more of these methods.

Layer

Layer refers to settings which cause two or more programs to sound simultaneously when a note is played.

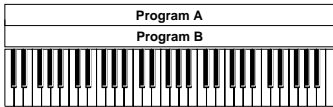

Layer:
Two or more programs sound simultaneously.

Split

Split refers to settings which cause different programs to sound on different areas of the keyboard.

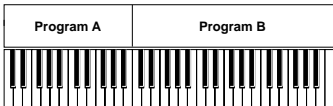

Split:
Different programs will sound in different areas of the keyboard.

Velocity switch

Velocity Switch refers to settings which cause different programs to sound depending on the **velocity** (keyboard playing dynamics).

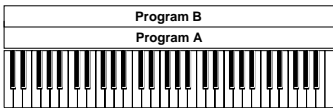

Strong ↑ Keyboard playing dynamics
Soft ↓
Velocity Switch:
Keyboard playing dynamics (velocity) switches between different programs.

On TRITON STUDIO, you can use a different program for each of up to eight timbres, and combine two or more of the above methods to create even more complex setups.

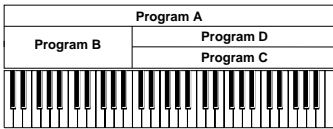

Strong ↑ Keyboard playing dynamics
Soft ↓
Example:
B and C/D are split. In the lower keyboard range, A and B are layered. In the higher keyboard range, C and D are switched by velocity and layered with A.

As an additional possibility, you can set the slope for a key zone or velocity zone so that the volume diminishes gradually. This lets you change a split into a **keyboard crossfade**, or a velocity switch into a **velocity crossfade**.

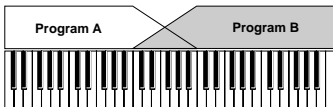

Keyboard X-Fade (keyboard crossfade):
As you play from low notes to high notes, the volume of A will fade out, and the volume of B will fade in.

The Compare function

As you are editing a combi, you can use the [COMPARE] key to listen to the previously saved version (as it was before you began editing). Pressing [COMPARE] again (the light goes dark) returns you to the version you are editing.

⚠ If you continue editing when the [COMPARE] key LED is lit, the LED will go dark, and the current setting will now be the sound that is recalled when the [COMPARE] key LED is dark.

Timbre 1–8 program, pan and volume

P1: Edit-Program/Mixer

Here you can assign programs to each timbre 1–8, and set the pan and volume for each one. (These settings can also be made in the Program Select and Mixer pages of P0: Play.)

Edit-Program/Mixer page

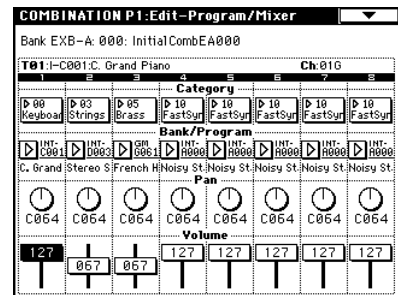

Category, Program Select (Bank/Program)

Assigns a program to each timbre.

note When the “**Bank/Timbre Program**” select menu is displayed, you can select programs by bank. When the “**Category/Timbre Program**” select menu is displayed, you can select programs from the 16 categories. (see p.35)

note You can also use the BANK [INT-A]–[EXB-G] keys to select the bank of the program.

MIDI If you wish to select programs by receiving MIDI program changes, do so in P0: Play.

Pan

Specifies the panning (stereo position) for each timbre. A setting of **C064** will reproduce the oscillator pan setting of the program. Adjusting this parameter will move the sound to left or right while preserving the pan relationship between the oscillators. A setting of **L001** is far left, and **R127** is far right.

Volume

Adjusts the volume of each timbre. Create the overall sound by adjusting the volume balance between timbres. The “**Volume**” setting is an important aspect of creating the sound, and this setting will have a significant effect on the overall impression produced by the Combination.

Settings for status, MIDI channel, and pitch parameters **P2: Edit-Trk Param**

MIDI Ch page

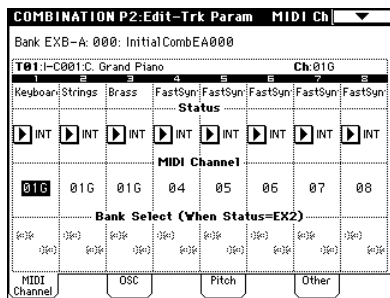

Status

Here you can specify the MIDI status of the internal tone generator assigned to each timbre. Normally when playing the internal tone generator of TRITON STUDIO, you will set this to **INT**. Set this to **Off** for timbres that you are not using. With settings of **Off**, **EXT**, or **EX2**, TRITON STUDIO will not sound. With settings of **EXT** or **EX2**, you can control an external tone generator connected via MIDI. (PG p.38)

MIDI Channel

Timbres that you wish to play from TRITON STUDIO's keyboard must be set to the global MIDI channel. Your playing on the keyboard is transmitted on the global MIDI channel, and will sound any timbre that matches this channel. Normally you will set this to **Gch**. When this is set to **Gch**, the MIDI channel of the timbre will always match the global MIDI channel, even if you change the global MIDI channel.

On some preloaded combinations that use the arpeggiator, timbres assigned to the arpeggiator may not have a "Status" of **INT** and "MIDI Ch" of **Gch**. The reason for this is that these settings are for timbres that sound only when the arpeggiator is on. This is a very useful technique for creating combinations that use the arpeggiator. Refer to "Arpeggiator settings in Combination and Sequencer modes" (p.132, PG p.44), and study the relationship between arpeggiator assignments, "Status," and "MIDI Channel."

Bank Select (when status=EX2)

This setting is valid when "Status" is set to **EX2**. It specifies the Bank Select message that will be transmitted from TRITON STUDIO.

OSC page

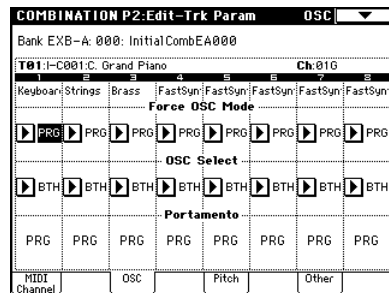

Force OSC Mode

Normally you will set this to **PRG** (the oscillator will play as set by the program settings). If you wish to force a polyphonic program to sound monophonically, set this either to **MN** (Mono) or **LGT** (Legato). Conversely, set this to **Poly** if you wish to force a monophonic program to play polyphonically (PG p.38).

OSC Select

Normally you will set this to **BTH** (Both). If the timbre is using a program whose "Oscillator Mode" is **Double**, and you want only **OSC1** or **OSC2** (not both) to sound, set this to **OSC1** (only **OSC1** will sound) or **OSC2** (only **OSC2** will sound).

Portamento

Normally you will set this to **PRG**. If you want to override the portamento setting specified in the program assigned to the timbre to be forced off, set this parameter to **Off**. Conversely, if you want to force the portamento to be on, or to change the portamento time, set this to a value of **001-127** to specify the portamento time.

Pitch page

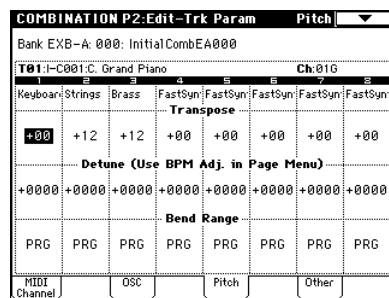

Transpose, Detune (BPM Adjust)

These parameters adjust the pitch of the timbre.

- In a layer-type combination, you can set two or more timbres to the same program, and create a richer sound by using "Transpose" to shift their pitch apart by an octave or by using "Detune" to create a slight difference in pitch between the two.
- In split-type combinations, you can use "Transpose" to shift the pitch (in semitone units) of the programs specified for each key zone.
- If you wish to change the playback pitch of a drum program, use "Detune." If you change the "Transpose" setting, the relationship between notes and drum sounds will change.

Adjusting the BPM of multisamples or samples created in Sampling mode

If a timbre's program uses multisamples or samples that you created in Sampling mode (or loaded in Disk mode) at a specific BPM value, you can use the page menu command "Detune BPM Adjust" to call up a new BPM value. This changes the BPM by adjusting the playback pitch. (PG p.39)

Other page

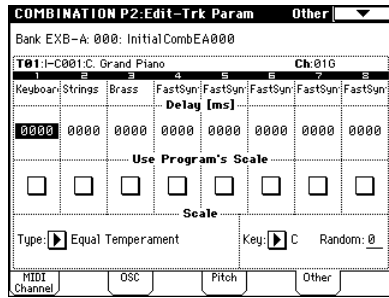

Delay [ms]

Specifies the amount of time before the program assigned to each timbre will sound. Specifies the time from when you play the keyboard until the program will sound. If you select **KeyOff** for this parameter, the timbre will sound when the note is released.

Use Program's Scale, Scale

Specifies the scale for each timbre. If you check "Use Program's Scale," the scale specified by the program will be used. Timbres for which this is **not checked** will use the **Scale** setting.

MIDI filter settings

P3: Edit-MIDI Filter

For each MIDI Filter item, you can specify whether or not the corresponding MIDI message will be transmitted and received. The **checked** items will be transmitted and received.

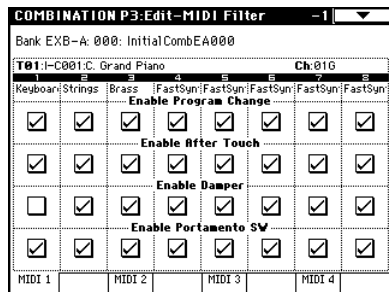

MIDI filter does not turn the function itself on/off, but specifies whether or not that MIDI message will be transmitted and received. For example if portamento is on, portamento will be applied to the sound of TRITON STUDIO even if "Portamento SW CC#65" is unchecked.

For example if you selected a bass program for timbre 1 and a piano program for timbre 2 to create a split-type combination, you could make the following settings so that pressing the connected damper pedal would apply the damper effect only to the piano program of timbre 2.

Set the P3: Edit-MIDI Filter-1 "Enable Damper" parameter

- Timbre 1 "Enable Damper": unchecked
- Timbre 2 "Enable Damper": checked

Layer, split, and velocity switch settings/Controller settings

P4: Edit-Zone/Ctrl

Key Zone page (Key zone settings)

Indicates settings such as layer, split, and keyboard cross-fade.

Specifies the range of notes that will be sounded by each timbre. Each area that sounds a timbre is referred to as a **Key Zone**. By setting key zones, you can create a combination in which different programs sound in different areas of the keyboard.

By combining key zones specified for each timbre, you can create **layered** or **split** combinations.

The upper and lower limits for the key zone of each timbre are set by the "Top Key" and "Bottom Key" respectively.

For example in the following diagram, timbres 1-3 are set to create a layered and split combination. This is specified by the key zone settings.

Timbres 2 and 3 create a layer. Timbre 1 and timbres 2/3 are split between the B3 and C4 note numbers.

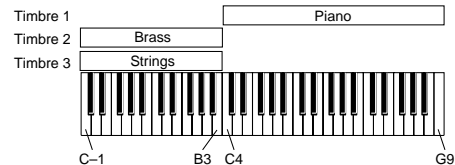

As an example here, we will explain how to create a combination like the one shown above.

① In the **P0: Play, Program Select** page or the **P1: Edit-Program/Mixer** page, use the "Program Select" area to select the program that will be used for each timbre 1-3.

- Select a piano program for timbre 1.
- Select a brass program for timbre 2.
- Select a strings program for timbre 3.

② In the **MIDI Ch** page of **P2: Edit-Trk Param**, set "Status" to **INT** for all the timbres that you wish to use, and set "MIDI Channel" to either **Gch** or to match the global MIDI channel (a "G" will be displayed after the channel number).

③ In the **Key Zone** page of **P4: Edit-Zone/Ctrl**, set "Top Key" and "Bottom Key."

- Set timbre 1 to a "Top Key" of **G9** and a "Bottom Key" of **C4**.

- Set timbres 2 and 3 to a "Top Key" of **B3** and a "Bottom Key" of **C-1**.

You can also enter these values by holding down the [ENTER] key and playing a note on the keyboard.

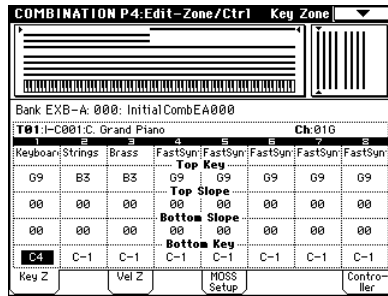

Key Zone Slope

Here you can specify the range of keys over which the original volume will be reached, starting at the top key and bottom key.

In the case of the above example, you could set the key zones so that a portion of timbres 1 and 2 overlaps (i.e., is layered) with timbre 3, and set "Top Slope" and "Bottom Slope" so that the sound changes gradually, instead of changing suddenly between B3 and C4.

Vel Zone page (Velocity zone settings)

Here you can make settings for velocity switching and velocity crossfading.

For each timbre, you can specify a range of velocities for which it will sound. The range of velocities for which a timbre will sound is called a **Velocity Zone**. By setting a velocity zone, you can set up a timbre which will be sounded only by notes played within a certain range of velocities, and not by notes played outside this Velocity Zone.

By combining timbres that have differing velocity zone settings, you can create **velocity switched** combinations.

The upper and lower limits of the velocity zone of each timbre are determined by the "Top Velocity" and "Bottom Velocity" respectively.

The following diagram shows an example of a velocity switched combination in velocity will switch between timbres 1 and 2 to play different programs. Such combinations are created by setting the velocity zone.

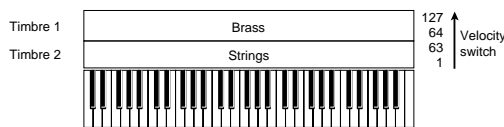

As an example, we will explain how to create a combination like the one shown above.

- ① In the P0: Play, Program Select page or the P1: Edit-Program/Mixer, Prog page, use the "Program Select" area to select the program that will be used for each timbre 1 and 2.
Select a brass program for timbre 1.
Select a strings program for timbre 2.
- ② In the MIDI Ch page of P2: Edit-Trk Param, set "Status" to INT for all the timbres that you wish to use, and set "MIDI Channel" to either Gch or to match the global MIDI channel (a "G" will be displayed after the channel number).
- ③ In P4: Edit-Zone/Ctrl Vel Zone page, set the "Top Velocity" and "Bottom Velocity."
Set timbre 1 to a "Top Velocity" of 127 and a "Bottom Velocity" of 64.
Set timbre 2 to a "Top Velocity" of 63 and a "Bottom Velocity" of 1.

You can also enter these values by holding down the [ENTER] key and playing a note on the keyboard.

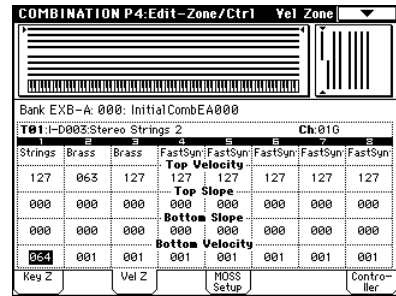

Velocity Zone Slope

Here you can specify the range of values over which the original volume will be reached, starting from the top velocity and bottom velocity.

In the case of the above example, you could set the velocity zones of the two timbres so that they partially overlap, and set "Top Slope" and "Bottom Slope" so that the sound changes gradually, instead of changing suddenly between velocity values of 63 and 64.

Control page (Controller settings)

For each combination, you can specify the functions of the B-mode functions of REALTIME CONTROLS knobs [1]–[4], and the [SW1] and [SW2.] (see p.145, PG p.43, 249, 250)

.....

Arpeggiator settings

P7: Edit-Arp.

Indicates settings for the arpeggiator (see p.132).

.....

Insert Effect settings

P8: Edit-Insert FX

Indicates the insert effects, and allows you to adjust their settings.

Specifies the routing for each timbre (i.e., how it is sent to the insert effect, master effects, and individual outputs). (see p.141)

.....

Master Effect settings

P9: Edit-Master FX

Indicates the master effects, and allows you to adjust their settings.

Here you can also make master EQ settings (see p.142).

Producing songs

TRITON STUDIO contains a 16-multi track MIDI sequencer. The sequencer acts as a hub, integrating TRITON STUDIO's numerous functions, allowing it to be used in a variety of situations including music production and live performance.

note Sampling or resampling can be performed in Sequencer mode (see p.115). You can also apply the TRITON STUDIO's effects to an external audio input source, for a wide range of possibilities. (see p.143)

! When you turn off the power, the settings made in Sequencer mode and the song data, cue list data, and any user pattern data that you recorded will not be backed up. If you wish to keep this data, you must save it on media (Floppy disk, hard drive etc.) before turning off the power, or perform a MIDI data dump to save the data on an external data filer etc.

If you wish to save the programs, track parameters, effects, and arpeggiator function settings etc. selected for a song as a template song, use the page menu command "Save Template Song."

Immediately after the power is turned on, TRITON STUDIO will not contain any cue list data or song data, so if you wish to playback a song on the sequencer, you must first load data from media or receive a MIDI data dump from a MIDI filer (see p.63, PG p.145, 161)

Features of the sequencer

- The sequencer lets you record a **maximum of 200,000 events** (note data etc.), up to **200** songs, and as many as **999** measures per song.
- Up to **20 cue lists** can be created. A cue list is an arrangement of up to 99 songs that will be played as a chain. You can specify the number of times that each song will repeat. A cue list can also be converted into a single song.
- The **arpeggiator function** can be used during playback or recording.
- The **RPPR (Realtime Pattern Play/Recording) function** can be used during playback or recording.
- **Sixteen different template songs** are built-in, and contain program and effect settings suitable for various musical styles. Up to sixteen original templates that you create can be saved as user template songs.
- **Five stereo insert effects, two master effects, and a stereo master EQ** can be used for each song.
- Timing resolution is a maximum of $\frac{1}{192}$.
- **Sixteen tracks** are provided for musical data, and a **master track** contains time signature and tempo data that controls the playback.
- A **track play loop function** lets you loop specified measures independently for each track.
- **150 preset patterns** ideal for drum tracks are built in. In addition, you can **create up to 100 user patterns** for each song. These patterns can be used as musical data within a song, or can be played by the RPPR function.
- Various methods of recording are supported, including **realtime recording** in which your performance on the keyboard and controllers (including MIDI control events) is recorded just as you play, and **step recording** in which the timing, length, and velocity of each note can be specified in the LCD as you input the pitches from the keyboard.
- The musical data and control events that you recorded can be edited in various ways (including **event editing** and many other edit commands).
- When the "Status" of a track is set to **INT** or **BTH**, an external sequencer can be used to play TRITON STUDIO as a **multi-timbral tone** generator. When the "Status" of a track is set to **BTH**, **EXT**, or **EXT2**, the sequencer of TRITON STUDIO can **play external tone** generators.
- Playback can be **synchronized with an external** MIDI device.
- TRITON STUDIO's **AMS (Alternate Modulation)** capability lets you use control changes for realtime control of the parameters of the programs used in a program. Its **MIDI Sync** abilities let you synchronize the LFO speed to changes in the tempo.
- **Dmod (Dynamic Modulation) functionality** lets you control effect parameters in realtime. You can also use **MIDI Sync** to synchronize the LFO speed or delay time to changes in the tempo.
- You can assign names not only to the song, but also to each pattern and track.
- Combination settings can be copied to a song.
- Sequencer data such as a song or cue list that you create can be saved in TRITON STUDIO's native format, or transmitted as a MIDI data dump.
- A song you created can be converted into SMF (Standard MIDI File) data. SMF songs can also be loaded.
- The **PLAY/MUTE/REC** and "SOLO On/Off" let you instantly play/mute any desired track on the fly.
- You can rewind or fast-forward while listening to the sound.
- The **[LOCATE]** key lets you move quickly to a desired location.
- Multisamples you create can be played back together with internal programs in Sequencer mode. The **Time Slice** function of Sampling mode lets you divide a rhythm loop sample and create performance data that corresponds to the divided samples. In Sequencer mode you can play this performance data, and adjust the playback tempo without affecting the pitch of the rhythm loop sample. You can also exchange the note numbers of the data, or modify the timing to freely re-create new rhythm loops.
- The TRITON STUDIO provides an **In-Track Sampling function** which lets you sample an external audio source while the song plays back, and will automatically create note data to trigger that sample at the appropriate point during the playback of the track.
- A song you create can be resampled to the hard disk. In Disk mode, this data can then be written to an audio CD by using the CDRW-1 option.

The structure of Sequencer mode

The following describes the structure of Sequencer mode. (See diagram below)

Songs

A song consists of tracks 1–16, a master track, song parameters such as the song name, effect, arpeggiator and RPPR parameters, and 100 user patterns.

A maximum of 200 such songs can be created on TRITON STUDIO.

Tracks 1–16 and the master track each consist of **setup parameters** located at the start location, and **musical data** within the track.

Setup parameters

Tracks 1–16

Bank/Program No.*, PLAY/MUTE/REC, Pan*, Volume*, Track Play Loop, Loop Start Measure, Loop End Measure, Play Intro, Status, MIDI Channel, Bank Select (When Status=EX2), Force OSC Mode, OSC Select, Portamento*, Transpose**, Detune**, Bend Range**, Delay, Use Program's Scale, MIDI Filter, Key Zone, Velocity Zone, Track Name, Arpeggiator Assign, IFX/Indiv.Out BUS Select, Send1(MFX1)*, Send2(MFX2)*

Master track

Time signature*, Tempo*

Musical data

Tracks 1–16

Note On/Off, Program Change (including Bank Select), Pitch Bend, After Touch (Poly After), Control Change, Pattern No.

* When you change the setting during realtime-recording, this will be recorded as musical data. This allows the starting settings to be modified during the playback.

** Musical data (MIDI RPN data) can be used to change the starting settings during playback.

For details on control changes and RPN, refer to PG p.260, 263.

Patterns

There are two types of patterns: preset patterns and user patterns.

- **Preset patterns:** Patterns suitable for drum tracks are preset in internal memory, and can be selected for any song.
- **User patterns:** Each song can have up to 100 patterns. When using a pattern in a different song, use the Utility menu commands "Copy Pattern" or "Copy From Song" etc. to copy the pattern. The pattern length can be specified in units of a measure.

Each pattern consists of musical data for one track. It is not possible to create patterns that contain multiple tracks. These patterns can be used as track musical data by being **placed in a track** (page menu command "Put to Track") or **copied to a track** (page menu command "Copy to Track"). Alternatively, you can use a pattern with the **RPPR function of a song**.

Cue List

A **cue list** allows you to playback multiple songs in succession. The TRITON STUDIO allows you to create 20 cue lists. Each cue list allows you to connect a maximum of 99 songs in any order, and to specify the number of times that each song will repeat.

The page menu command "Convert to Song" lets you convert the two or more songs in a cue list into a single song. This allows you to use a cue list to create the backing, then convert the cue list into a song and add solo phrases on unused tracks.

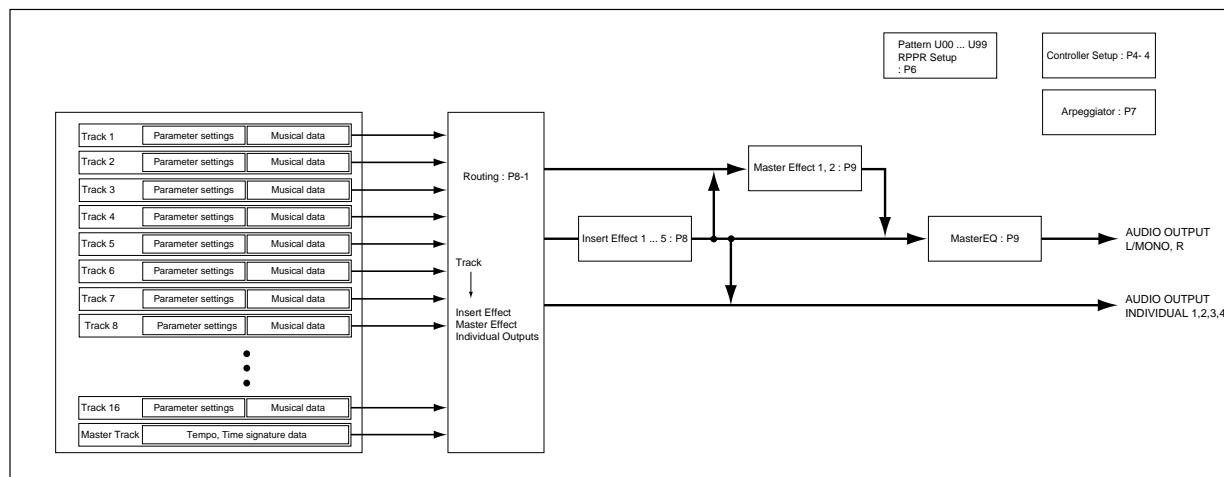

Preparations for recording

On the TRITON STUDIO, “recording” is the process by which your performance on the keyboard and controllers is written into the tracks and patterns of a song as data. This section explains how to make preparations for recording a song, such as assigning a program to each track, and setting the volume.

note By loading a template song, you can easily make appropriate settings for various styles of music.

① Assign a program to each track.

In the Sequencer P0: Play/REC, Program T01–08/T09–16 page, use “Program Select” to assign a program to each track.

At this time you can press the “Category” popup and select programs by category. (PG p.51)

You can also use the Utility menu command “Copy From Combi” to copy settings from a combination (PG p.95, PG p.52).

note When assigning a program, you can use “Track Select” to select the track for which you are making assignments, and try playing the sound.



② Set the pan and volume of each track.

In the Sequencer P0: Play/REC, Mixer T01–08/T09–16 page, “Pan” sets the pan of each track, and “Volume” sets the volume of each track.



③ Specify the tone generator and MIDI channel that will be played by each track.

In the Sequencer P2: Trk Param, MIDI Ch T01–08/T09–16 page, “Status” specifies whether each track will sound the internal tone generator or an external tone generator. “MIDI Channel” specifies the MIDI channel for each track.

If the track “Status” is set to INT, playing the track data or operating the TRITON STUDIO’s keyboard or controllers will cause the TRITON STUDIO’s internal tone generator to be played.

If “Status” is set to EXT, EX2, or BTH, playing the track data or operating the TRITON STUDIO’s keyboard or controllers will cause an external tone generator to be sounded and controlled. (The MIDI channel of the

external tone generator must be set to match the “MIDI Channel” of TRITON STUDIO tracks that are set to EXT, EX2 or BTH.)

If “Status” is set to BTH, both the external tone generator and the TRITON STUDIO’s own tone generator will be sounded and controlled.

If you are using the TRITON STUDIO’s Sequencer mode as a 16-track multi-timbral tone generator, set this parameter to INT or BTH. (PG p.62)

In general, you should set “MIDI Channel” to different channels 1–16 for each track. Tracks that are sent to the same MIDI channel will sound simultaneously when either is recorded or played.

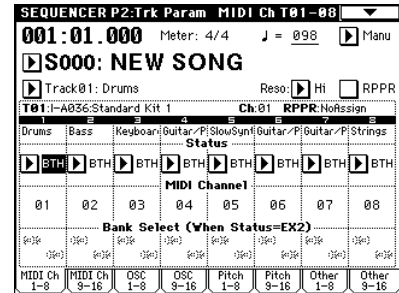

④ Adjust the effect settings.

Make settings for each effect in Sequencer P8: Insert Effect and P9: Master Effect. (PG p.141, PG p.83)

⑤ Set the tempo and time signature.

Make these settings in Sequencer P0: Play/REC. “J (Tempo)” sets the tempo, and “Meter” sets the time signature. (PG p.49)

⑥ As necessary, set “Reso” to specify the quantization resolution.

(PG p.51)

⑦ Make other settings as necessary.

As necessary, make arpeggiator settings (Sequencer P7: Arpeggiator) and MIDI filter settings (Sequencer P3: MIDI Filter). (PG p.49–86)

When you are finished making these settings, the basic setup is complete. Record as described in “Recording methods” (PG p.83) and following sections.

Monitoring just a specific track/Muting just a specific track (Solo/Mute functions)

The TRITON STUDIO provides a Solo function that lets you play only a specific track 1–16, and a Mute function that silences only specific tracks. These functions can be used in various ways. For example you can intentionally mute or solo specific tracks, or listen only to the rhythm section of the previously-recorded tracks while you record new tracks.

Let’s try out the Mute and Solo functions.

① Load a song.

As described on p.20, load the demo songs, and select any song.

② Access the Sequencer P0: Play/REC, Program T01–08/T09–16 page.

Press the SEQUENCER [START/STOP] key.

③ Press track 1 “PLAY/MUTE/REC.”

The display will change from “PLAY” to “MUTE,” and the playback of track 1 will no longer be heard. In this way, the “mute” function allows you to silence a specified track until the track is un-muted.



Press track 2 “PLAY/MUTE/REC.”

The display will change, and the playback of track 2 will also be muted.



To cancel muting, press “PLAY/REC/MUTE” once again.

④ Press track 1 “SOLO ON/OFF.”

The display will change from “SOLO OFF” to “SOLO ON,” and this time, only the performance of track 1 will be heard. To play back only a specified track by itself in this way is known as “soloing” the track (turning Solo on).



note If both Mute and Solo are used, the Solo function will be given priority.

⑤ Press track 2 “SOLO ON/OFF.”

The display will change, and only the playback of tracks 1 and 2 will be heard.



To switch Solo off, press “SOLO ON/OFF” once again. Press “SOLO ON/OFF” for both tracks 1 and 2.

The display will change, and the playback of tracks 1 and 2 will be muted. If the Solo function is turned off for all tracks, playback will be according to the “PLAY/MUTE/REC” settings.

note By using the page menu command “Solo Selected Track,” you can listen to the sound of only the selected track. This is convenient when you want to set track parameters or to make effect settings. (PG p.52)

[LOCATE] settings

By pressing the [LOCATE] key you can move to a specified location.

The location is specified by the Utility menu command “Set Location.” You can also hold down the [ENTER] key and press the [LOCATE] key to set the location even during playback (PG p.54).

When you select a song, the “LOCATE” setting will automatically be set to 001:01.000.

Normally you will leave this set to 001:01.000., to return you to the beginning of the song.

Recording methods

This section describes the ways in which you can record on the TRITON STUDIO.

Recording a track

There are two ways to record to a track: **realtime recording** and **step recording**. You can choose from six types of realtime recording.

In addition, you can use **event editing** to modify data that has been recorded or to insert data, and use **track editing** operations such as **Create Control Data** to insert data such as bend, after touch, and control changes.

Recording a pattern

There are two ways to record a pattern: **realtime recording** and **step recording**. For realtime recording, only one recording type (loop) is available.

In addition, you can use **event edit** operations to modify data that has been recorded or to insert data.

The page menu command “Get From Track” can be used to take musical data from a desired area of a track, and use it as the musical data for a pattern. Conversely, the page menu commands “Put to Track” and “Copy to Track” can be used to place or to copy the musical data of a pattern in a track.

Realtime recording on a track

This is a method of recording in which your playing on the keyboard and your operations of controllers such as the joystick are recorded in realtime.

This method of recording is normally used one track at a time, and is called **single track recording**.

As an alternative, **multitrack recording** allows you to simultaneously record multiple channels of data onto multiple tracks. This is the method you will use when using the RPPR function and the arpeggiator function to record multiple tracks of musical data at once, or when you playback existing sequence data on an external sequencer and record it onto TRITON STUDIO’s sequencer in realtime (PG p.85).

○ These settings are made in Sequencer P0: Play/REC, Preference page “Recording Setup.”

• Overwrite

With this method, the musical data previously recorded on a track is overwritten by the newly recorded data. When you perform overwrite recording on a previously-recorded track, its musical data will be deleted and replaced by the newly recorded data. Normally you will use this method to record, and then modify the results by using other types of realtime recording or event editing.

① Use “Track Select” to select the track that you want to record.

- ② Set the “Recording Mode” to Over Write.

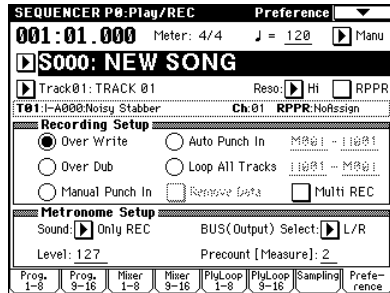

- ③ In “Location,” specify the location at which you wish to begin recording.
 - ④ Press the SEQUENCER [REC/WRITE] key, and then press the SEQUENCER [START/STOP] key.
- If the “Metronome Setup” is still set to the default settings, the metronome will sound for a two-measure pre-count, and then recording will begin. Play the keyboard and move controllers such as the joystick to record your performance.

- ⑤ When you finish playing, press the SEQUENCER [START/STOP] key.
- Recording will end, and the location will return to the point at which you begin recording. If you press the [PAUSE] key instead of the SEQUENCER [START/STOP] key, recording will pause. When you press the [PAUSE] once again, recording will resume. When you are finished, press the SEQUENCER [START/STOP] key to stop recording.

• Overdub

With this method, the newly recorded musical data is added to the existing data. When you perform overdub recording on a previously-recorded track, the newly recorded data will be added to the previously-recorded data. It is best to select this mode if you will be recording additional control data, recording a drum pattern, or recording the tempo in the master track. With this mode, data can be added without erasing the existing performance data.

- ① Use “Track Select” to select the track that you want to record.
- ② Set the “Recording Mode” to Over Dub.

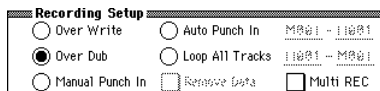

- ③ For the rest of the procedure, refer to steps ③–⑤ of “Overwrite.”

• Manual punch-in

While the song is playing, you can press the SEQUENCER [REC/WRITE] key or a connected pedal switch at the desired location to start or stop recording. With this method, the musical data previously on the track is overwritten by the newly recorded data.

- ① Use “Track Select” to select the track that you want to record.

- ② Set the “Recording Mode” to Manual Punch In.

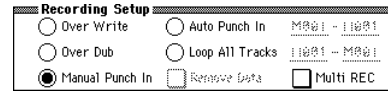

- ③ In “Location,” specify a location several measures earlier than the point at which you wish to begin recording.
- ④ Press the SEQUENCER [START/STOP] key. Playback will begin.
- ⑤ At the point at which you wish to begin recording, press the SEQUENCER [REC/WRITE] key. Recording will begin. Play the keyboard and operate controllers such as the joystick to record your performance.
- ⑥ When you finish recording, press the SEQUENCER [REC/WRITE] key. Recording will end (playback will continue).

note Instead of pressing the SEQUENCER [REC/WRITE] key in steps ⑤ and ⑥, you can use a foot switch connected to the ASSIGNABLE SWITCH jack. Set the Global P2: Controller page “Foot SW Assign” to Song Punch In/Out (see p.125).

- ⑦ Press the SEQUENCER [START/STOP] key. Playback will stop, and you will return to the location that you specified in step ③.

• Auto punch-in

First you must specify the area that will be re-recorded. Then recording will occur automatically at the specified area. With this method, the musical data previously on the track is overwritten by the newly recorded data.

- ① Use “Track Select” to select the track that you want to record.
- ② Set the “Recording Mode” to Auto Punch In.

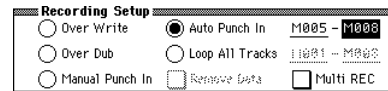

- ③ In “M (Auto Punch In Start Measure), “M (Auto Punch In End Measure)” specify the area that you wish to record.
- For example if you specify M005–M008, recording will occur only from measure 5 to measure 8.

- ④ In “Location,” specify a location several measures earlier than the point at which you wish to begin recording.
- ⑤ Press the SEQUENCER [REC/WRITE] key, and then press the SEQUENCER [START/STOP] key. Playback will begin. When you reach the starting location you specified in step ③, recording will begin. Play the keyboard and operate controllers such as the joystick to record your performance. When you reach the ending location you specified in step ③, recording will end. (Playback will continue.)
- ⑥ Press the SEQUENCER [START/STOP] key. Playback will stop, and you will return to the location you specified in step ④.

• Loop All Tracks

This method lets you continue recording as you add musical data.

The specified region can be recorded repeatedly. This is ideal when recording drum phrases, etc.

- ① Use “Track Select” to select the track that you want to record.
- ② Set the “Recording Mode” to Loop All Tracks.
If “Multi REC” is checked, it will not be possible to select Loop All Tracks.

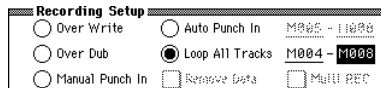

- ③ In “M (Loop Start Measure), “M (Loop End Measure)” specify the area that you wish to record.
For example if you specify M004–M008, recording will occur repeatedly (as a loop) from measure 4 to measure 8.
- ④ In “Location,” specify a location several measures earlier than the point at which you wish to begin recording.
- ⑤ Press the SEQUENCER [REC/WRITE] key, and then press the SEQUENCER [START/STOP] key.

Playback will begin. When you reach the starting location you specified in step ③, recording will begin. Play the keyboard and operate controllers such as the joystick to record your performance.

When you reach the ending location you specified in step ③, you will return to the starting location, and continue recording.

The musical data that is loop-recorded will be added to the previously-recorded data.

- ⑥ You can also erase specific data even while you continue loop recording.
If you press the SEQUENCER [REC/WRITE] key during loop recording, all musical will be removed from the currently selected track as long as you continue pressing the key.

By checking the “Remove Data” check box you can erase only the specified data. During loop recording, press the note that you wish to delete, and only the data of that note number will be deleted from the keyboard as long as you continue pressing that note.

Similarly, bender data will be deleted as long as you tilt the joystick in the X (horizontal) direction, and after touch data will be deleted as long as you apply pressure to the keyboard.

When you are once again ready to record musical data, uncheck the “Remove Data” check box.

- ⑦ Press the SEQUENCER [START/STOP] key.
Playback will end, and you will return to the recording start location that you specified in step ④.
If Loop All Tracks is selected, normal playback will be looped as well.

• Multi (multitrack recording)

Multitrack recording allows you to simultaneously record onto multiple tracks, each with a different channel. This method can be used with overwrite, overdub, manual punch-in, and auto punch-in recording.

Using the arpeggiator to record multiple tracks simultaneously

A multi-track performance using the arpeggiator function can be recorded using multi recording.

When simultaneously recording multiple tracks using the RPPR function

You can use multitrack recording to simultaneously record the playback of multiple tracks that are being triggered by the RPPR function. For the procedure, refer to “Realtime-recording an RPPR performance” (p.94).

When simultaneously recording multiple tracks of MIDI data from an external sequencer.

- ① Make sure that the TRITON STUDIO’s MIDI IN and the external sequencer’s MIDI OUT are connected by a MIDI cable.

If they are not connected, turn off the power, make the connection, and then turn the power back on again. (PG p.258)

- MIDI** If the EXB-mLAN option is installed, MIDI data can be received from an mLAN device. (PG p.141)

- ② Set the MIDI Clock (Global P1: MIDI page “MIDI Clock”) to External, so that TRITON STUDIO will synchronize to the MIDI clock of the external sequencer.

Make sure that “Receive Ext. Realtime Commands” is checked.

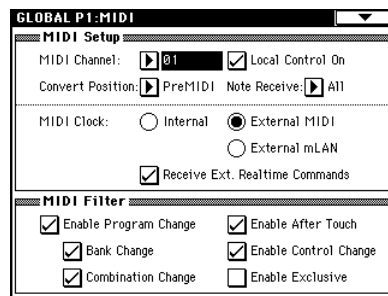

- ③ Create a new song, and in the Sequencer P0: Play/REC, Preference page, check the “Multi REC” check box. Set the “Recording Mode” to Over Write.



- ④ Select the P0: Play/REC, Program T01–08/T09–16 page.
For the tracks that you are not recording, set “PLAY/MUTE/REC” to PLAY or MUTE.
- ⑤ In P2: Trk Param, MIDI Ch page “MIDI Channel,” specify the MIDI channel for each track.
Set the MIDI channel of each external sequencer track to match the MIDI channel of each TRITON STUDIO track. Data of the corresponding channel will be recorded on each TRITON STUDIO track.
Make sure that “Status” is set either to INT or BTH.
- ⑥ Press the [LOCATE] key to set the location to 001:01.000.
- ⑦ Press the SEQUENCER [REC/WRITE] key to enter recording-standby mode.
- ⑧ Start the external sequencer.

The TRITON STUDIO’s sequencer will receive the MIDI Start message transmitted by the external sequencer, and will automatically begin recording.

⑨ **When the song ends, stop the external sequencer.**

TRITON STUDIO's sequencer will receive the MIDI Stop message transmitted by the external sequencer, and will automatically stop recording. You can also press the SEQUENCER [START/STOP] key on TRITON STUDIO itself to stop recording.

⑩ **Playback.**

In the Global P1: MIDI page, set "MIDI Clock" to **Internal**.

Set "Tempo Mode" to **Auto**.

When you press the SEQUENCER [START/STOP] key, playback will begin.

note If the correct sounds do not play immediately after playback is started, you may be able to solve the problem by using the page menu command "Event Edit" (Sequencer P5: Track Edit) to edit the **Program Change** data.

Step recording

This is a method of recording where you specify the note timing, note length, and velocity etc. in the LCD screen, and use the keyboard to input the pitches. (p.52) Only note-on/off data can be recorded with this method.

Event Edit and Create Control Data

Note data is the only type of data that can be recorded in step recording. However there are ways to record other types of data, aside from the realtime mode. You can use the Event Edit and Create Control Data functions. Event Edit is intended as a way to edit previously-recorded data, but you can also use it to modify program numbers or insert control changes. Create Control Data is a function that lets you create and insert controller data that changes smoothly between two specified values over the specified length of time. This is used to input bend, after touch, and control change data etc.

Realtime-recording to a pattern

Here's how you can use realtime recording to create a pattern. User patterns can be accessed by the RPPR function in the same way as preset patterns, and can be **copied** to or **placed** in a song. Playback data from a track can also be copied to a pattern.

⚠ Before you begin recording a pattern, turn off the memory protect setting in Global mode (p.57).

When realtime-recording a pattern, a pattern of the specified number of measures will playback repeatedly, allowing you to continue adding musical data to it.

- ① **Create a new song, and as described in "Preparations for recording," set the track to the program that will be used by the pattern.** (p.82)
- ② **Access the Sequencer P6: Pattern/RPPR, Pattern Edit page.**

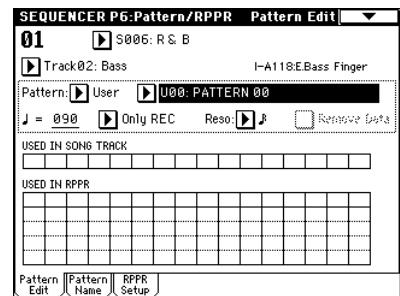

- ③ **Use "Track Select" to select the track that you will use to record the pattern.**
The pattern will sound with the program and other settings of the selected track.
- ④ **Set "Pattern (Pattern Bank)" to User, and set "Pattern Select" to U00.**
User patterns U00-U99 can be created for each song.
- ⑤ **Select the page menu command "Pattern Parameter".**
A dialog box will appear.

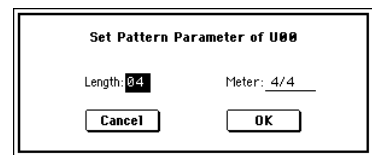

- ⑥ **Set the number of measures in the pattern to a "Length" of 04 (four measures), and set "Meter" to a time signature of 4/4. Press the OK button.**
- ⑦ **As necessary, set "Resolution" to apply realtime quantization.**
- ⑧ **Begin realtime recording.**
You can record in the same way as you did when recording tracks with Loop All Tracks. (p.85)
Press the SEQUENCER [REC/WRITE] key, and then press the SEQUENCER [START/STOP] key.
After the pre-count, pattern recording will begin. Play the keyboard and operate the joystick and other controllers to record your performance. When you reach the end of the pattern, the sequencer will return to the beginning of the pattern and continue recording. If you continue recording, the newly recorded data will be added to the previously-recorded data.

- ⑨ If you want to delete specific data while you continue pattern recording, you can press the SEQUENCER [REC/WRITE] key or check the “Remove Data” check box.

For details refer to step ⑥ of “Loop All Tracks” (p.85).

- ⑩ Press the SEQUENCER [START/STOP] key to stop recording.

If you made a mistake or decide to re-record, press the SEQUENCER [START/STOP] key to stop recording, and press the [COMPARE] key. Then begin the pattern recording procedure again as in step 8.

Control data in pattern recording

 To record control data in a pattern, you should restore the control data to its normal value within the pattern. If you fail to restore the normal value, unnecessary control data may remain in a “stuck” position when you place the pattern in a song or use the RPPR function to play the pattern. However, the following control data will be automatically reset to the following values when the song or RPPR function finishes playing the pattern, or when playback is halted.

Controller	Reset value
Modulation 1 (CC#01)	00 (zero)
Modulation 2 (CC#02)	00 (zero)
Expression (CC#11)	127 (max)
Ribbon controller (CC#16)	64 (center)
Damper switch (CC#64)	00 (zero)
Sostenuto switch (CC#66)	00 (zero)
Soft switch (CC#67)	00 (zero)
EG sustain level (CC#70)	64 (center)
Resonance level (CC#71)	64 (center)
EG release time (CC#72)	64 (center)
EG attack time (CC#73)	64 (center)
Low pass filter cutoff (CC#74)	64 (center)
EG decay time (CC#75)	64 (center)
LFO1 speed (CC#76)	64 (center)
LFO1 depth (pitch) (CC#77)	64 (center)
LFO1 delay (CC#78)	64 (center)
Filter EG intensity (CC#79)	64 (center)
SW1 modulation (CC#80)	00 (zero)
SW2 modulation (CC#81)	00 (zero)
Channel after touch	00 (zero)
Pitch bender	00 (zero)

Using the arpeggiator for pattern recording

If the arpeggiator is set to operate for the track that is selected for “Track Select,” you can turn on the ARPEGGIATOR [ON/OFF] key and record the performance of the arpeggiator into the pattern.

For details on arpeggiator settings, refer to p.94 and PG p.81.

Song editing methods

A variety of editing operations can be performed on a song. Here we will give some examples of how you can use various editing operations on the song you created in "Producing a song" (p.49), to prepare for creating a cue list as described in the next section.

note Load the SEQ_DM1.SNG file that you saved on p.54. For the loading procedure, refer to p.63. In the explanations that follow, we will assume that the song you created has been loaded into song S000. After loading the song, press the [SEQ] key to enter Sequencer mode.

1. Copying a song

Here's how to copy a song. This is convenient when you want to create different variations based on a song.

① Create a new song.

Access the Sequencer P0: Play/REC, Program T01-08 page. Choose "Song Select," use the **numeric keys** to input the song number that you want to newly create, and press the [ENTER] key. (For example, press the [1] key and then the [ENTER] key.) A dialog box will appear.



Decide on the number of measures, input the number in "Set Length," and press the OK button.



A new song will be created. Next we will copy the song settings and playback data of another song into this newly created song.

② Select the page menu command "Copy From Song."



A dialog box will appear. Select the song that you want to copy (i.e., the copy source). If you select All, all song settings and playback data will be copied from that song. If you select Without Track/Pattern Events, settings other than Play Loop and RPPR will be copied. For this example, select All.

Press the OK button to execute the copy.

③ As described in steps ① and ②, create one more new song (S002), and copy song S000 to it.

2. Naming a song

Here's how to assign a name to a song you created.

① Choose "Song Select," to select a song.

For this example, select song 002.

② In the Sequencer P0: Play/REC, Program T01-08 page, select the page menu command "Rename Song."

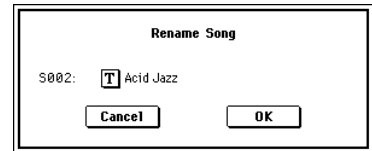

A dialog box will appear. Press the text edit button to access the text dialog box.

Press the Clear button, and input CHORUS (p.40). When you are finished inputting the name, press the OK button.

Press the OK button once again to execute the Rename operation.

③ As described in steps ① and ②, assign a name of INTRO to S000, and VERSE to S001.

3. Setting the number of measures in the song

Here's how to specify the number of measures in the song. By default, this is set to 64 measures. If you real-time-record for more measures than this, the song length will be the amount of measures you have recorded.

① Select song S000: INTRO.

② Select the Sequencer P5: Track Edit, Track Edit page.

In the P5: Track Edit page, press the [MENU] key to access the Jump page. Press the P5: Track Edit.

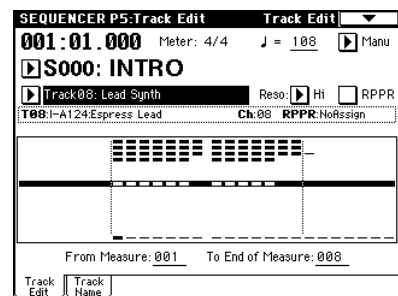

③ Access the page menu.

This contains various commands for editing tracks and measures.

Press the "Set Song Length."

Memory Status	Delete Measure	Quantize
Step Recording	Insert Measure	Shift/Erase Note
Event Edit	Repeat Measure	Modify Velocity
Erase Track	Copy Measure	FF/REW Speed
Copy Track	Move Measure	Set Location
Bounce Track	Create Ctrl Data	Set Song Length
Erase Measure	Erase Ctrl Data	

A dialog box will appear.

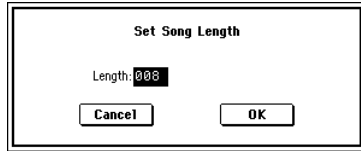

Input the number of measures for the song. For this example, select 008 (8 measures) and press the OK button.

The performance data from measures 1–8 will remain, and the data of subsequent measures will be deleted. When you press the SEQUENCER [START/STOP] key to play the song, playback will stop at the end of the 8th measure.

▲ If you are using Track Play Loop, check whether the measures specified for “Loop Start Measure” and “Loop End Measure” would be deleted. If they would be deleted, use “Move Measure” (PG p.72) etc. to move the data into the playback area before you execute this operation.

④ **Mute tracks.**

Press the [EXIT] key to select P0: Play/REC, and access the Program T01–08/T09–16 page.

Mute all tracks other than tracks 3 and 4. When you play back, you will hear only the electric piano and guitar performances.



⑤ **As described in steps ①–④, set song S001: VERSE to 008 (8 measures), making it an eight measure song.**

Then mute all tracks other than tracks 1–3. When you play back, you will hear only the drums, bass, and electric piano.

⑥ **As described in steps ①–④, set song S002: CHORUS to 008 (8 measures), making it an eight measure song.**

4. Changing the key (transposing/modulating)

Here's how to change the key of a song.

- ① **Select song S002: CHORUS.**
- ② **Select the Sequencer P5: Track Edit page.**
- ③ **Use “Track Select” to select T02 as the track whose pitch will be changed.**
- ④ **Specify the measures for which the key will be changed.**

Select “From Measure,” and use the VALUE controllers to set this to 001. Next select “To End of Measure,” and specify 008.

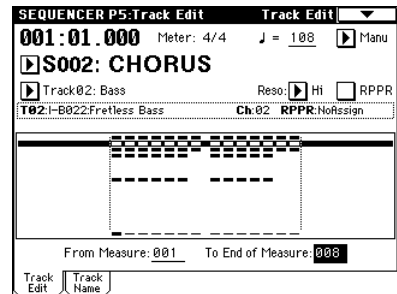

⑤ **Select the page menu command “Shift/Erase Note.”**

A dialog box will appear. If you did not specify the range of measures in step ④, set “From Measure”–“To Measure” to specify the range that will be edited.

Turn on the Replace radio button, and set “Shift Note” to +003. (PG p.74)

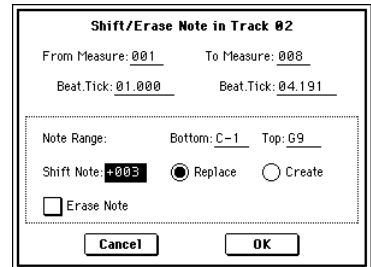

Press the OK button. The pitch of track 2 will be raised three semitones.

⑥ **Use the same procedure to raise the pitch three semitones for each track on which performance data is recorded. However, do not change the key of track 1 which uses a drum kit.**

▲ If you change the key of a track that is using a drum kit, the relationship between the notes and the instruments of the drum kit will be shifted, and the sequence will not play the correct rhythm instruments.

About editing

Song editing

In addition to copying and renaming a song, other operations such as Delete can be performed from the Utility menu commands in pages such as Sequencer P0: Play/REC (PG p.52).

Track editing

Event Editing allows you to edit or insert data in a recorded track. In addition, commands such as Create Control Data (which lets you insert pitch bend, aftertouch, or control change data) and other commands for deleting, copying, inserting, or moving tracks can be accessed from the page menu command in the Sequencer P5: Track Edit (PG p.68).

Pattern editing

Using the page menu commands of the Sequencer P6: Pattern/RPPR, Pattern page, you can use event editing to modify the recorded data or insert new data, and execute commands to delete, copy, or bounce patterns (PG p.77).

Creating and playing a Cue List

A **cue list** allows you to play multiple songs in succession. For example you can create a separate song for each portion (introduction, melody A, melody B, chorus, and ending) of a composition, and use the cue list to specify the order of each portion and the number of times that it will be repeated to complete the song. If you want to change the structure of the song, the cue list lets you do so in an efficient way.

You can also use this as a jukebox function that will playback completed songs in the order you specify.

Cue List								
Step	Song	Repeat						
01	S000: Intro	02	Intro	Intro	A	A	B	Chorus
02	S001: A	02	Chorus	A	A	B	Chorus	Chorus
03	S002: B	01	A(Solo)	Chorus	Chorus	Chorus	Ending	Ending
04	S003: Chorus	02						
05	S001: A	02						
06	S002: B	01						
07	S003: Chorus	02						
08	S001: A (Solo)	01						
09	S003: Chorus	03						
10	S004: Ending	02						

Each unit in a cue list is called a “step,” and each step contains a song number and the number of repeats.

Here we will use a cue list to combine the previously-created songs S000: INTRO, S001: VERSE, and S002: CHORUS.

① Select Sequencer P1: Cue List.

With the default settings, song S000 will be selected for “Step” 01, and End will be selected for “Step” 02.

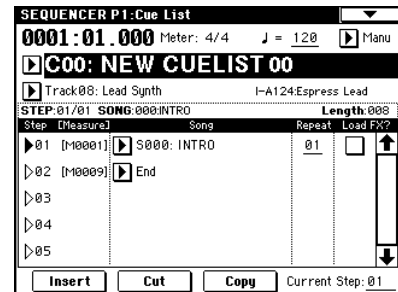

② Add a song to the Step area.

Select the “Song” for Step 02, and press the Insert button. A song will be added to step 02. Use the VALUE controller to select S001: VERSE.

In the same way, select the Step 03 “Song,” and press the Insert button to add a song to Step 03. Set this to S002: CHORUS.

If you press Cut button, the selected step will be deleted. If you press the Insert button key, the deleted step will be inserted.

If you press the Copy button, the selected step will be copied. If you press the Insert button, the copied step will be inserted.

③ Set the last step to End.

If you set this to Continue to Step01, the cue list will play back repeatedly.

- ④ In “Repeat,” specify the number of times that the song for that step will be repeated. For this example, set Step 02 S001: VERSE to 02.
- ⑤ Specify whether effect settings will also be switched when the song at each step is played back. If you want to effect settings to change, check the “FX” check box.

For this example, check the “FX” check box for Step 01, which loads the effects.

- ⑥ To play back at the tempo that was specified for each song, set “Tempo Mode” to Auto.

If this is set to Manu (Manual), playback will use the tempo specified by “♩=”.

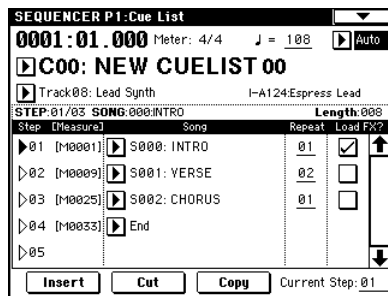

- ⑦ When you press the SEQUENCER [START/STOP] key, playback will begin from the step that is specified as the “Current Step.”

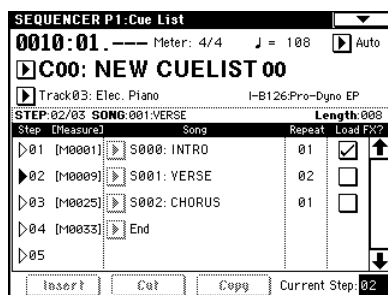

- “Step”: The arrow will indicate the currently playing step. ▶ indicates the currently selected “Step.” If you set “Current Step” while stopped, the display will change.
- “M****”: Indicates the starting measure of that step.
- “Meter”: Indicates the currently-playing time signature. This cannot be changed.
- The name of a cue list can be specified by the “Rename Cue List” page menu command.
- When you play the keyboard, the program of the track selected by “Track Select” will sound. If a different program is selected for each song, the program specified for the currently playing song will sound.

What to do when playing back a cue list and the songs do not transition smoothly

Depending on the effect settings, a certain amount of time may be required for the effects to be switched. If this occurs, the playback will not be smoothly connected from song to song.

To ensure a smooth transition from song to song, check “FX” for “Step” 01. Do not check “FX” for the remaining steps. This way, the effect settings will be made before playback begins, and there will be no time lag when cue list playback is started or when switching from song to song. Although it will not be possible to change effect types within the cue list, you can use dynamic modulation

or MIDI control changes such as Effect Control to control the effects within the cue list, for example applying reverb more deeply on certain songs, or raising the LFO speed for a specific song. We recommend this method if you will be using a cue list to construct the song.

When you execute the page menu command “Convert to Song”, the effect settings of the “Step” 01 song will be specified for the song that results from the conversion. Even if “FX” is not checked, there may be cases in which a time lag in the transition between songs, depending on the musical data of the song. Also, there may be cases in which the musical data is not played at the correct timing at the transition between songs. If this occurs, you can edit the musical data of the song, or convert the cue list to a song for playback. If you use “Convert to Song” to convert the cue list to a song, there will be no time lag during playback at the transition between songs, and the musical data will be played at the correct timing.

Creating multiple songs for use in a cue list

If you want to create multiple songs for use in a cue list, it is a good idea to make the various necessary settings (program and other settings for each track, effect settings, etc.) for one song (e.g., S000), and then use the page menu command “Copy From Song” in SEQ 1.1 etc. to copy it to other songs so that the settings will be consistent.



- ▶ After your cue list is finished and you convert it into a song, the track settings (program, pan, volume, etc.) of each step will be converted into playback data and will be reproduced, but if the MIDI channel settings-from song to song do not match, it may not be possible to convert the playback state of the cue list into a song.

Using a foot switch to switch the Step

You can use a foot switch to switch the Step.

If you set “Repeat” to FS, a foot switch connected to the ASSIGNABLE SWITCH jack will control the timing at which the song stops repeating. Set “Foot Switch Assign” (Global P2: Controller page) to Cue Repeat Control.

Converting a song

Although it is not possible to record additional material onto tracks in a cue list, you can convert a cue list to a song, and then record solos etc. on vacant tracks. You will also need to convert a cue list to a song if you wish to save it on a floppy disk etc. as SMF data.

- 1 Select the page menu command “Convert to Song”.

A dialog box will appear.

- 2 In “To Song,” specify the destination song number for the converted data.

The cue list name will automatically be assigned as the song name of the converted data. (For details and cautions regarding “Convert to Song,” refer to PG p.61.)

If you select a new song as the conversion destination, it is not necessary to specify “Set Length” in the dialog box that appears. The number of measures in the converted song will be used. Press the OK button, and the Convert Cue List dialog box will appear.



- 3 Press the OK button.

The cue list will be converted into a song. Access the P0: Play/REC page, select the song number that you specified as the conversion destination, and check the results.

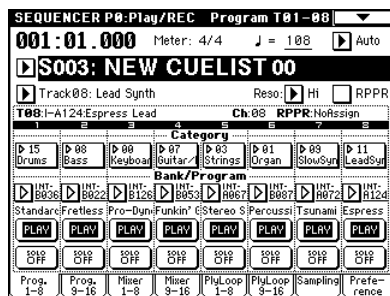

Creating and recording RPPR (Realtime Pattern Play/Record)

This section explains how to assign a pattern to RPPR, and how to play and record. (“Playing with the RPPR (Realtime Pattern Play/Recording) function” p.33)

Creating RPPR data

- 1 Create a new song. (p.88)

- 2 Specify the program for each track.

For this example we will use a template song. Use the Utility menu command “Load Template Song” to load P14: Hip Hop/Rap. It is not necessary to copy the patterns. (p.49)

- 3 Select the Sequencer P6: Pattern/RPPR, RPPR Setup page.

In this page, the RPPR function is automatically turned on.

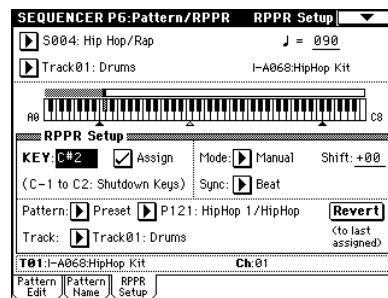

- 4 Use “KEY” to select the key to which the pattern will be assigned.

Select C#2. This can also be selected by holding down the [ENTER] key and playing a note. C2 and lower keys are used to stop playback, and cannot be assigned.

- 5 Check the “Assign” check box.

- 6 Set Pattern Bank to the Preset pattern type, and set “Pattern Select” to pattern P121: HipHop 1/HipHop.

- 7 Set “Track” to Track01: Drums.

The selected pattern will be played according to the settings (program, etc.) of the track you select here.

- 8 Assign patterns to other keys.

For “KEY,” press the [△] key to select D2.

Press the REVERT button.

The settings for “Assign,” “Pattern (Pattern Bank),” “Pattern Select,” and “Track” will be set to the values that were specified earlier (in steps 5–7).

Choose “Pattern Select,” and press the [△] key to select P122: HipHop 2/HipHop.

note By using “REVERT” in this way, you can work efficiently when the patterns to be assigned have consecutive or nearby numbers, or use the same track.

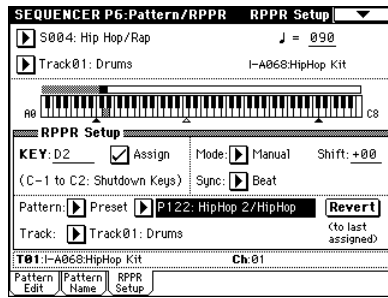

Use the above method to assign several patterns from the range of P123: HipHop 3/HipHop–P135: HipHop 15/HipHop.

⑨ Press the C#2 key.

The assigned pattern will play.

Take your finger off the C#2 key, and press the D2 key.

The pattern will change, and playback will begin. At this time, the pattern operation will depend on the “Sync” and “Mode” setting.

Set “KEY” to C#2, and set “Sync” to Measure. Make the same setting for D2.

Now press the notes consecutively. Notice that the patterns operate in a different way.

With the “Measure” setting, patterns will be handled in one-measure units. The second and subsequent patterns will start in sync with the end of previously played pattern. If you change the “Mode” setting to Once, the entire pattern will playback to the end even if you release your finger from the keyboard immediately.

note To stop playback, either press the same key once again, or press the C2 or lower key.

For details on “Sync,” “Mode,” and “Shift,” refer to PG p.80.

The assigned keys will be shown as a keyboard graphic in the LCD screen.

note Unassigned keys can be used for normal keyboard performance. Use “Track Select” to select the track that will be played from the keyboard. For example you might assign backing patterns such as drums and bass to the C#2–B2 keys and use these keys to control pattern playback, and use keys C3 and above to play solos in realtime. It is a good idea to keep the assigned keys together in this way.

RPPR playback

Let’s use the RPPR you created to perform in the Sequencer P0: Play/REC page.

- ① Select Sequencer P0: Play/REC.
- ② Check the “RPPR” check box.

The RPPR function will be turned on. Set the on/off for each song.

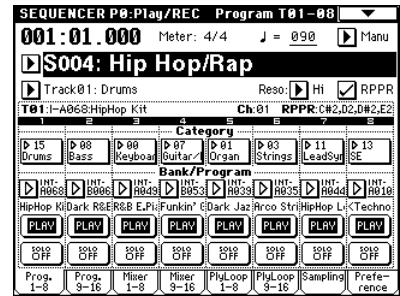

③ Play the keyboard, and patterns will begin playing according to the RPPR settings.

- Pattern playback for a key with a “Sync” setting of Beat or Measure will sync to the playback of the first pattern. (PG p.80 “Sync”)
- If you are playing the pattern in synchronization (when “Sync” is Beat, Measure, or SEQ), the pattern will start accurately if you play the note slightly earlier than the timing of the beat or measure. Even if you play the note slightly later than the beat or measure (but no later than a 32nd note), it will be considered to have started at the beat or measure, and the beginning of the pattern will be compressed so that the remainder of the playback will be correct.

MIDI If you wish to trigger the RPPR function from an external MIDI device, use the MIDI channel that is selected for “Track Select.”

④ To turn off the RPPR function, uncheck the RPPR check box.

Play RPPR while a song plays back

RPPR can be played in synchronization with the playback of a song.

Pattern playback for a key with a “Sync” setting of SEQ will synchronize to the playback of the song. (PG p.80 “Sync”)

Start the song playback, and then press the key. The pattern playback will start in synchronization with the measures of the song.

⚠ Synchronization will be lost if you use the [<< REW] or [FF >>] keys while a song is playing.

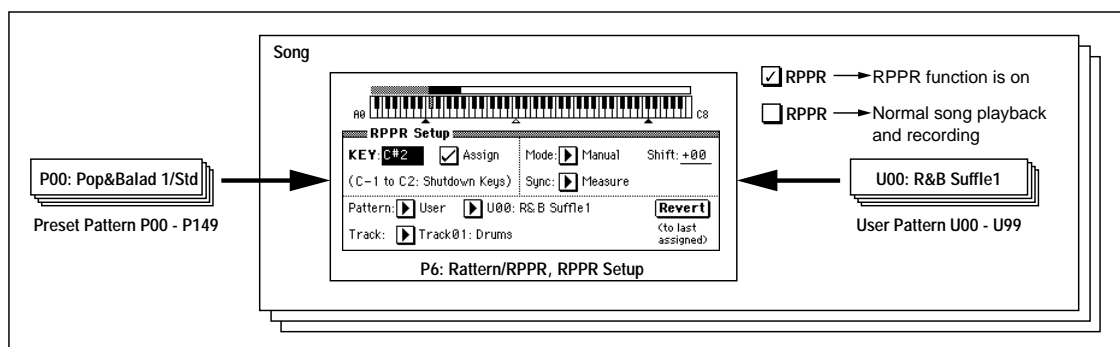

note If you want RPPR pattern playback to begin at the moment that song playback begins, it is a good idea to insert an empty measure containing no musical data before the song playback begins.

note If the song is stopped, the pattern will synchronize to the timing of the arpeggiator function.

Realtime-recording an RPPR performance

An RPPR performance can be recorded in realtime. If you are using only one track (Track01: Drums) as in “Creating and recording RPPR” (p.92), set “Track Select” to Track01: Drums, and use single track recording in which only one track will be recorded.

Even if RPPR uses only one track, use multi-track recording if you will be selecting another track in “Track Select” and recording its performance at the same time. You should also select multi-track recording if you created the RPPR data using multiple tracks rather than just a single track, and want to simultaneously record the performance of multiple tracks.

note The RPPR pattern will be recorded as performance data on the tracks used by the pattern.

Here we will explain how you can simultaneously record a performance that uses both RPPR and the arpeggiator.

- For each RPPR pattern, set “Sync” to SEQ.

With a setting of SEQ, patterns played by the RPPR function while the sequencer is playing or recording will start in synchronization with the measures of the sequencer.

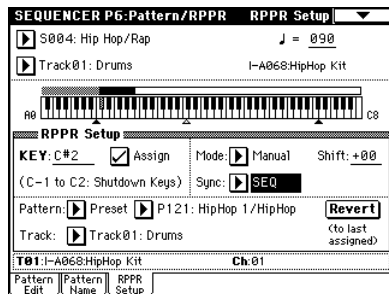

- We will use the arpeggiator to play the bass pattern. Follow these settings.

Set “Track Select” to Track02: Bass.

Select the Sequencer P7: Arpeggiator, Setup T01-08 page, and set the track 2 “Arpeggiator Assign” to A. (Make sure that A is checked for “Arpeggiator Run.”)



Select the Sequencer P7: Arpeggiator, Arpeggiator A page, and set “Pattern” to U038 (I-A/B).



Set “Gate” and “Velocity” to Step. Do not check “Key Sync.”

Press the ARPEGGIATOR [ON/OFF] key. (The LED will light.)

- In the Sequencer P0: Play/REC, Preference page, check the “Multi REC” check box.



If “Recording Mode” is set to Loop All Tracks,” it will not be possible to select Multi REC. Set the “Recording Mode” to Over Write.

- Select the P0: Play/REC, Program T01-08 page.

For all tracks, the “PLAY/MUTE/REC” indication will show REC.

The track played by RPPR will be recorded simultaneously with the track played by the arpeggiator. Set “PLAY/MUTE/REC” to PLAY or MUTE for all tracks other than tracks 1 and 2, which we will be recording.

Make sure that “Track Select” is set to Track02: Bass. Your keyboard playing on keys not assigned to the RPPR function can be recorded on the track specified by “Track Select.”

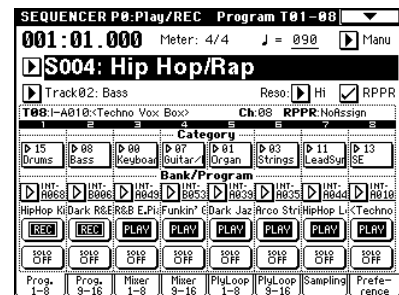

- Make sure that the “RPPR” check box is checked.
- Press the [LOCATE] key to set the location to 001:01.000.
- Press the SEQUENCER [REC/WRITE] key, and then press the SEQUENCER [START/STOP] key.

Press a key that plays an RPPR pattern, and one or more keys that play the arpeggiator.

If you press a key during the pre-count before recording, the pattern playback and arpeggio performance will begin simultaneously when recording begins, and will be recorded.

Record the RPPR pattern playback and arpeggio performance.

 When recording the playback of patterns triggered by RPPR, the timing of the recorded events may be slightly skewed. If this occurs, try setting “Reso” (Realtime Quantize Resolution) to a setting other than Hi.

⑧ **When you are finished performing, press the SEQUENCER [START/STOP] key.**

Recording will end, and the sequencer will return to the location at which recording began.

If you made a mistake during your performance or would like to re-record, you can use the Compare function (press the [COMPARE] key) to re-record as many times as you wish.

⑨ **If you want to record other tracks, un-check the “Multi REC” or “RPPR” check boxes as necessary.**

In step ③, uncheck the “Multi REC” check box to defeat multi-track recording.

In step ⑤, uncheck the “RPPR” check box to turn off the RPPR function.

Recording the sounds of a combination

Here's how you can copy the sounds of a combination to multiple tracks, and record your performance.

note Make sure that the global MIDI channel (Global P1: MIDI, “MIDI Channel”) is set to 01.

① **Create a new song. (p.88)**



② **Execute the page menu command “Copy From Combi.”**

A dialog box will appear.

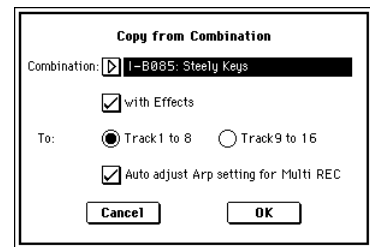

Select the combination that you want to copy (i.e., the copy source).

Press the COMBI BANK [INT-B] key, then press numeric keys [8], [5], and finally press the [ENTER] key. I-B085: Steely Keys will be selected.

We will copy the effect settings of the combination as well, so **check** the “With Effects” check box.

Since we want to copy the settings of the combination's eight timbres to tracks 1–8, select **Track 1 to 8**.

If you have selected Track 1 to 8, you will be able to select “Auto adjust Arp setting for Multi REC.” If you **check** this check box, the MIDI channel etc. of some of the tracks will automatically be adjusted to ensure that the same sound as was used during recording will be reproduced by the playback when you perform multi-track recording with the arpeggiator turned on.

 Depending on the combination settings, it may be necessary to make additional changes to the track settings.

note In order to use the “Auto adjust Arp setting for Multi REC” function, the combination to be copied must have been written with the ARPEGGIATOR [ON/OFF] key turned on.

Press the OK button to execute the copy.

Notice that when you execute this command, the “PLAY/REC/MUTE” setting of each track will be set automatically.

In the Sequencer P0: Play/REC, Preference page, the “Multi REC” check box will be checked.



If you are using the arpeggiator, press the ARPEGGIATOR [ON/OFF] key to turn it off, and then turn it on again.

③ **Begin recording.**

Press the [LOCATE] key to set the location to 001:01.000.

Press the SEQUENCER [REC/WRITE] key, and then press the SEQUENCER [START/STOP] key.

If you play a B3 note or lower during the pre-count before recording, the arpeggio pattern will start from the beginning at the moment that recording begins. Record your performance.

④ **When you are finished performing, press the SEQUENCER [START/STOP] key.**

If you made a mistake or want to re-record, you can use the Compare function (press the [COMPARE] key) to re-record as many times as you want. (The “Multi-REC” check box will be unchecked when you use Compare, so you will need to check it again.)

If the recorded performance is not reproduced correctly during playback

If you use the page menu command “Copy From Combi” to copy the settings of a combination, and then perform multi-track recording with the arpeggiator turned on, there may be cases in which the performance during recording is not reproduced correctly during playback.

Multiple tracks that are set to the same MIDI channel are combined into a single stream of performance data during recording. If there is a track with the same MIDI channel as the track being played by the arpeggiator, the data played by the arpeggiator will be combined with the performance data that was played manually, and all of this data will be sounded by each track of the same channel (if “Status” is INT).

In such cases, you can solve the problem by changing the MIDI channel of the track that is played by the arpeggiator, and then creating a track that will drive the arpeggiator.

If the recorded performance is not reproduced by the playback, check the following conditions.

note These settings can be executed automatically if you check “Auto adjust Arp setting for Multi REC” in the page menu command “Copy From Combi.” Normally, you will check this to execute the settings. In this case, these adjustments will not be necessary, but you can verify here that the automatic adjustments have been made.

- **Sequencer P7: Arpeggiator, Setup T01-08 page “Arpeggiator Run” A, B, and “Arpeggiator Assign” settings**

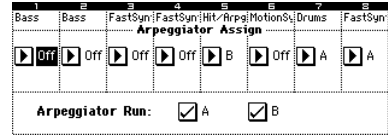

- **Sequencer P2: Trk Param, MIDI Ch T01-08 page “MIDI Channel” settings**

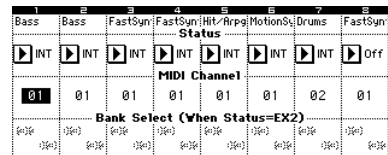

If “Arpeggiator Run” A and B are checked, and the arpeggiator is assigned to a track, make sure that “MIDI Channel” is set to other than 01.

MIDI Make sure that the global MIDI channel (Global P1: MIDI, “MIDI Channel”) is set to 01.

Arpeggiator Run	MIDI Channel ^{*1}	Correction
If either “A” or “B” are checked	01 only	Correction required
	01 02, 01 03, etc.	No correction required
If both “A” and “B” are checked	01 only	Correction required
	01 02, 01 03, etc.	Correction required for only one
	01 02 03, etc.	No correction required/ Correction required ^{*2}

- *1. If the “MIDI Channel” of multiple tracks operated by the arpeggiator is set only to 01, refer to the lines for “01 only.” If the “MIDI Channel” settings are 01 and one other channel, such as 01 and 02, or 01 and 03, then refer to the lines for “01 02, 01 03 etc.” If the “MIDI Channel” settings are 01 and multiple other MIDI channels, such as 01 and 02 and 03, then refer to the line for “01 02 03, etc.”
- *2. Correction is necessary only if the tracks operated by a single arpeggiator are using only “MIDI Channel” 01. In some cases, correction may also be necessary if the two arpeggiators use the same MIDI channel.

 Depending on the combination settings, it may also be necessary to change the track settings as well.

In the screens shown above, combination INT-C005: “In the Pocket” has been copied using “Copy From Combi.” As described in steps ① and ② of the procedure given earlier, try actually copying this to see for yourself. For the arpeggiator settings of this combination, refer to p.130. Taking this setting as an example, determine whether correction is necessary, and if necessary, what needs to be corrected.

“Arpeggiator Run” A and B are checked, and “MIDI Channel” 01 and 02 are selected. Corrections must be made. Correction is necessary for one of the arpeggiators. If you perform multi-track recording with these settings, the MIDI channels of T01, 02, 03, 04, 05, and 06 are the same, so the low-register bass (T01 and T02), the high-register synth brass/pad (T03, T04 and T06), and the synth mallet played by arpeggiator B (T05) will have their performance data combined into one stream, and the performance will not be reproduced at playback. (T08 is a dummy track used to trigger arpeggiator A.)

- ① **So that the synth mallet played by arpeggiator B can be recorded separately, change the MIDI channel of T05.**

Select the Sequencer P2: Trk Param, MIDI Ch T01–08 page, and change the T05 “MIDI Channel” to 03.

- ② **Add settings for triggering arpeggiator B.**

Select the Sequencer P2: Trk Param, MIDI Ch T09–10 page, and for track 9 (or any unused track), turn “Status” Off, and set the “MIDI Channel” to 01. (T09 will be a dummy track used to trigger arpeggiator B.)

- ③ **Select the Sequencer P7: Arpeggiator, Setup T09–16 page. Set the track 9 Assign to B.**

This will produce the following settings.

Track	T01	T02	T03	T04	T05	T06	T07	T08	T09
Assign	Off	Off	Off	Off	B	Off	A	A	B
Status	INT	INT	INT	INT	INT	INT	INT	Off	Off
MIDI Ch.	01	01	01	01	03	01	02	01	01

This completes the corrections. In the Sequencer P0: Play/REC, Preference page, set “Track Select” to any track whose MIDI channel is 01. Check the “Multi REC” check box and perform multi-track recording.

Caution and other functions in Sequencer mode

TRITON STUDIO song data and its compatibility

The following two types of song data can be loaded from Media into TRITON STUDIO’s sequencer.

- **Song data saved in TRITON STUDIO’s own format**
This data is only for this instrument.

However, it is partially compatible with the TRITON/TRITONpro/TRITONproX/TRITON-Rack (Multi) (PG p.279). It cannot be loaded into other instruments.

Since the performance will be faithfully reproduced, including detailed settings of this instrument, you should use this format to save song data that is intended for playback on this instrument.

- **Standard MIDI Files**

This format is not able to provide a totally faithful reproduction of the performance on TRITON STUDIO in the way that TRITON STUDIO’s own format does (although there will be no problem for normal playback), but does provide compatibility with other SMF-compatible devices.

To load or save song data etc., use Disk mode. (p.59, 63, PG p.155)

The Compare function

When you perform realtime recording, step recording, or track editing, this function allows you to make before-and-after comparisons.

-  If you continue editing when the [COMPARE] key is lit, the key will go dark. This now becomes the musical data that will be selected when the [COMPARE] key is dark.

Operations for which Compare is available

- **Recording to a track**
- **Track Edit**
All commands except for the Utility menu commands “Memory Status” and “Rename Track” of the Sequencer P5: Track Edit page.
- **Recording to a pattern**
- **Pattern Edit**
All commands except for the page menu commands “Memory Status,” “Rename Pattern,” “FF/REW Speed,” and “Rename Track” of the Pattern/Sequencer P6: RPPR, Pattern Edit page.
- **Song Edit**
Sequencer P0–P4 and P7–P9 pages: Page menu commands “Delete Song” and “Copy From Song”
Sequencer P1: Cue List page: Page menu commands “Convert to Song” and “Copy Song”

In general, track and pattern event data can not be returned to its original state.

Comparing song parameters is possible only during song editing (when executing a page menu command).

Operations for which Compare is not available

- Editing song parameters
- Page menu commands other than those listed above (in Operations for which Compare is available)

Memory Protect

Before you record a track or pattern, or edit the musical data, you will need to turn off the memory protect setting in Global mode. (PG p.57)

About MIDI

Track status "status"

You can make settings for TRITON STUDIO's sequencer to specify whether it will sound the internal tone generator or an external tone generator.

When Track Status "Status" (P2: Trk Param, MIDI Ch T01-08/T09-16) is set to **INT**, operating TRITON STUDIO's keyboard and controllers will sound and control TRITON STUDIO's own tone generator.

When "Status" is set to **EXT**, **EX2** or **BTH**, operating TRITON STUDIO's keyboard and controllers will sound and control the external tone generator. (The MIDI channel of the external tone generator must match the "MIDI Channel" of the track that is set to EXT, EX2 or BTH.) With a setting of BTH, both the external tone generator and TRITON STUDIO's tone generator will sound and be controlled.

1	2	3	4	5	6	7	8
Drums	Bass	Keyboard	Guitar/Pi	SlowSyn	Guitar/Pi	Guitar/Pi	Strings
Status							
▶ INT	▶ INT	▶ INT	▶ INT	▶ EXT	▶ EX2	▶ BTH	▶ INT
MIDI Channel							
01	02	03	04	05	06	07	08
Bank Select (When Status=EX2)							
⌂	⌂	⌂	⌂	⌂	000	⌂	⌂
⌂	⌂	⌂	⌂	⌂	000	⌂	⌂

If you wish to use the Sequencer mode of the instrument as a 16-track multi-timbral tone generator, select INT or BTH. (PG p.62 "Status")

Synchronizing the sequencer with an external MIDI device

The record/playback tempo of TRITON STUDIO's sequencer can be synchronized to an external MIDI device such as a sequencer or rhythm machine (PG p.266).

Sampling settings

Features of sampling on the TRITON STUDIO

- You can perform 48 kHz 16-bit linear mono or stereo sampling.
- The TRITON STUDIO is shipped with 16 Mbytes of sample memory (RAM) and an internal hard drive. When sampling, data is written into either sample memory or the internal hard drive. The 16 Mbyte **sample memory (RAM)** allows approximately 2 minutes 54 seconds of mono sampling (or approximately 1 minute 27 seconds of stereo sampling). By installing 72-pin SIMM boards, you can expand sample memory to a maximum of 96 Mbytes (three 32 Mbyte SIMM boards; replacing the factory-installed 16 Mbyte SIMM with a 32 Mbyte SIMM). In this case, you can record up to six samples of approximately 2 minutes 54 seconds each (mono) or approximately 1 minute 27 seconds each (stereo), for a total 17 minutes 28 seconds of monaural sampling time (approximately 8 minutes 44 seconds of stereo). Samples you record into sample memory (RAM) can be used as tone generator waveforms. However, this data will be lost when the power of the TRITON STUDIO is turned off, so you must save any sample data that you want to keep. The **hard disk** lets you record up to 80 minutes as a single sample file in either mono or stereo (monaural: approximately 440 Mbytes, stereo: approximately 879 Mbytes). This will create a WAVE file. If a sample (WAVE file) that was sampled to the hard disk is loaded into sample memory (RAM), it can be used as a tone generator waveform. A sample (WAVE file) of up to 16 Mbytes (mono) or 32 Mbytes (stereo) (if sample memory has been expanded to 32 Mbytes or greater) can be loaded into sample memory (RAM). WAVE files can also be written to the CDRW-1 option or to a CD-R/RW connected to the SCSI connector, to create an audio CD.
- A maximum of 1,000 multisamples and 4,000 samples can be created.
- In Disk mode, you can load multisample/sample data from various types of media.
- Korg format or Akai (S1000/3000 samples, mapped multisamples only) format sample data, and AIFF or WAVE format sample data can be loaded. (Once data has been loaded into the TRITON STUDIO, it will all be treated as Korg format sample data.) Sample data created on the TRITON STUDIO can be exported (output) as an AIFF or WAVE format sample file.
- The external audio source that you are sampling can be processed by the five insertion effect to apply effects such as a compressor or EQ. The LFO frequency or delay time of the effect can be specified as a BPM value, which is highly effective when sampling phrase loops etc. (In Sampling mode, only the insert effects can be used. In Program, Combination, and Sequencer modes, the master effects can also be used.)

- Sampling can be initiated by the SAMPLING [START/STOP] key, note-on, threshold, or the SEQUENCER [START/STOP] key. (The available methods will depend on the mode.) Threshold allows you to initiate sampling when the input signal exceeds the threshold level you specify. In Sampling mode, you can also specify a pre-trigger setting.
- The analog audio inputs support mic and line level signals. Digital audio input via S/P DIF IN supports 48 kHz or 96 kHz sampling rates. Digital audio input via mLAN (when the EXB-mLAN option is installed) supports a sampling rate of 48 kHz.
- Audio data can be sampled from an audio CD inserted in the CDRW-1 option or a SCSI-connected external CD-R/RW drive. Sampling in the digital domain from a CD ("ripping") can also be performed.
- Sampled data can be converted automatically (or manually, using an easy operation) into a program and used with the TRITON STUDIO's HI synthesis system. (In Sampling mode, use "Convert MS To Program." In Program, Combination, or Sequencer mode, use "Select Bank & Smp1 No.") Once a multisample/sample has been converted into a program, you can make filter, amp, and effect settings and play it as a program. Such a program can also be used in Combination mode or Sequencer mode. Samples you record can also be used as drum samples in a drum kit.

Sampling in Program, Combination, and Sequencer modes

- A performance in Program, Combination, or Sequencer modes can be resampled internally, with all audio remaining in digital form. This lets you resample a performance that uses the TRITON STUDIO's filters, effects, arpeggiator, and sequencer etc.
- External audio sources from the various input jacks can be sampled. A performance played on the TRITON STUDIO can be mixed with the external audio source and sampled, or you can sample just the external audio source while monitoring the performance played on the TRITON STUDIO. The master effects can also be applied to the signal being sampled.
- In Sequencer mode when you sample an external audio source while listening to the playback of the song, note data can be automatically created in a track. This "In-Track Sampling" function lets you sample vocals or guitar while you play the sequencer – just as if you were recording on a multi-track recorder.
- The song playback in Sequencer mode can be resampled to the hard disk. Then in Disk mode, you can edit the order of songs and use the CDRW-1 option to write them as an audio CD.

Editing in Sampling mode

- In Sampling mode, the sample data you sampled or loaded from various media (including WAVE and AIFF formats) can be assigned to an index (zone) to create a multisample.

- The waveform can be viewed in the LCD screen, and edited by a variety of waveform editing commands that include rate convert (down-sampling) and reverse playback.
- Start, loop start, and end addresses can be specified in units of a single sample. Loop tune, reverse playback, and loop lock functions are also supported.
- The **Use Zero function** automatically searches for zero-cross points, making it easy to find the beginning or end of the waveform, or locations that will not produce noise when the sample is played back.
- The grid function displays a BPM-based grid on the waveform display, helping you to create loops or make waveform edits that match the desired BPM.
- Each multisample allows you to create up to 128 indices. Each index consists of a sample assignment, a key zone, an original key, a playback pitch, and settings such as level.
- The “Keyboard & Index” display lets you edit a multisample while viewing the assignments and zones of each sample.
- Sample names and multisample names of up to 16 characters can be assigned. Sample names and multisample names can also be viewed in Disk mode (PG p.157 “Translation”).
- The **Time Slice function** automatically detects the attack portions of a kick or snare etc. in a rhythm loop sample (a looped pattern of drums etc.), and divides it into separate rhythm instrument sounds. A pattern corresponding to the divided samples is created automatically, so that you can immediately use the Sequencer mode RPPR function to play the pattern and adjust the tempo without changing the pitch. You can also do things such as adjusting the pitch of only the snare, replacing it with a different sample, or changing the playback timing on the sequencer, in this way creating a new rhythm loop based on the rhythm loop you started with. (Stereo samples are supported.)
- The **Time Stretch function** lets you modify the tempo without changing the pitch of a sample. You can select either Sustaining (suitable for sustain-type instruments such as strings or vocals), or Slice (suitable for rhythm loops on decay-type instruments such drums). Stereo samples are supported.
- The **Crossfade Loop function** is an important looping tool that helps smooth out irregularities in long loops which contain complex material. By executing Crossfade Loop, you can eliminate this problem and create natural-sounding loops.
- The **Link (with Crossfade) function** allows you to join two samples into a single sample. You can also crossfade the overlapping portion of the samples at this time, so that the volume changes gradually, producing a natural-sounding transition.
- The BPM Adjust function (playback pitch adjust) lets you adjust the playback pitch of each index so that the loop frequency matches the desired BPM value.
- You can use resampling (auto) to automatically apply effects to a sample and create a new sample.

How Sampling mode is organized

This section describes how sampling on the TRITON STUDIO is organized. (See the lower diagram on the following page)

Sampling frequency and bit resolution

As shown in the diagram, sampling reads the level of the analog signal at fixed intervals along the time axis, and stores the levels in memory as digital data.

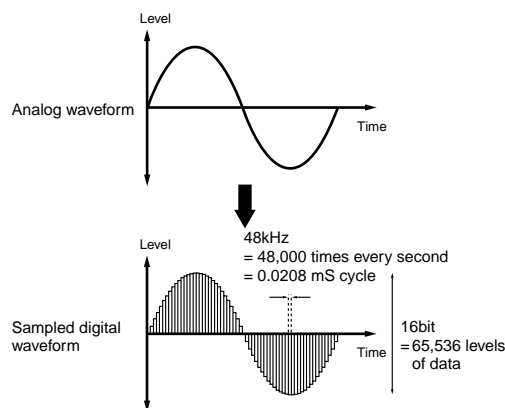

The “fixed intervals” mentioned above are generally expressed as the “sampling frequency.” 48 kHz (kilohertz) means that sampling is performed 48,000 times each second, and that the interval is $1 \text{ (second)} / 48,000 \text{ (times)} = \text{approximately } 0.00002083 \text{ (seconds)} = \text{approximately } 0.02083 \text{ mS (millisecond)}$.

The higher the sampling frequency is, the closer to the original analog signal the waveform in memory will be.

Each level is read, and converted into digital data. The accuracy at this time is determined by the bit resolution. This process converts an analog signal with infinite resolution into a digital signal with finite resolution. With 16 bit resolution, each level is indicated in 65,536 steps (the sixteenth power of two).

The greater the bit resolution is, the closer to the original analog signal the waveform in memory will be.

48 kHz 16 bit sampling is the same quality as in audio devices such as DAT. A CD uses 44.1 kHz 16 bit sampling, which is a slightly lower sampling frequency.

Samples and Multisamples

Samples

The data that is recorded (sampled) into internal memory or loaded from a file is referred to as a sample or sample file. Samples consist of the actual waveform data, and parameters that specify how the data will be played back, such as Start, Loop Start, and End Address. Samples can be used in multisamples and drum kits.

The TRITON STUDIO can hold a maximum of 4,000 samples in its internal memory.

note The TRITON STUDIO can share a single waveform among multiple samples. This allows you to create multiple samples with different playback addresses from the same waveform without wasting internal memory. For example, suppose that you have waveform data that records a voice saying "One-Two-Three." This single piece of waveform data could be shared by three samples, with the playback of sample A producing "One-Two-Three," sample B producing "One-Two," and sample C producing "Two-Three." (PG p.92).

Multisamples

A multisample consists of settings that make one or more samples sound in different areas of the keyboard. A multisample consist of between one and 128 "indexes." Each index contains parameters that specify the sample that will playback, the zone in which it will playback, the original pitch key, the playback pitch, and level etc.

Using multisamples

When sampling an instrument that is able to produce a wide range of pitches, such as a piano, recording just one sample and applying it (playing it back) over the entire pitch range will not produce a natural-sounding result. By using a multisample you can record separate samples for each pitch range, and assign these samples to their respective pitch ranges to avoid any unnatural sounds during playback.

All of the instrumental sounds in the TRITON STUDIO's internal preset ROM multisamples are constructed in this way. For example, you might record one sample per octave, and assign each of these samples to an index (key-board area).

By assigning multiple samples such as phrase samples or rhythm loops to a multisample and arranging them across the keyboard, you can play multiple samples simultaneously. Since a different phrase could be assigned to each key, you can perform just as though you were using a pad-type sampler. Alternatively, these samples could be assigned at one-octave intervals, and played as phrase variations with different playback pitches.

The TRITON STUDIO can hold a maximum of 1,000 multisamples in its internal memory.

A multisample can be selected as the oscillator for a program, and played as a program. In a combination, they can be combined with preset programs, and used in a multi. They can be used with the arpeggiator to produce interesting results (for example, by using the arpeggiator to automatically play sound effects or spoken samples).

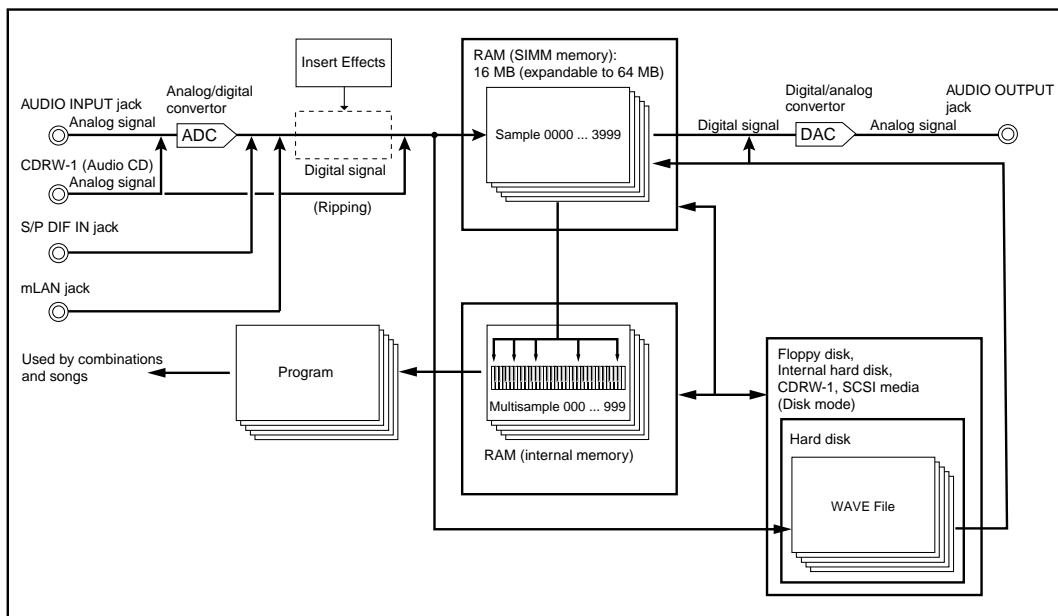
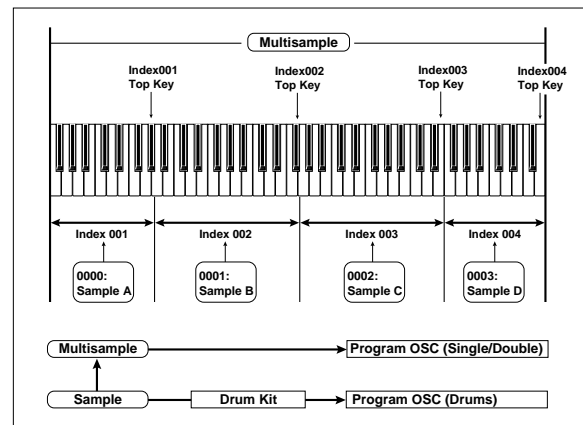

Preparations for sampling

⚠ The multisample and sample data in the sample memory (RAM) is not backed up when the power is turned off. If you wish to keep this data, you must save it onto a floppy disk, internal hard drive or external SCSI device before turning off the power. When the power is first turned on, memory will not contain any multisample or sample data. You must first load previously-saved data before you can play-back or edit any sample data (☞ p.37).

1. Connecting an input device and making *Input* settings

Connecting an input device

Here's how to connect an external audio source. On the TRITON STUDIO you can input audio signals from the AUDIO INPUT 1 and 2 jacks, the S/P DIF IN jack, or the mLAN jack (if the EXB-mLAN option is installed).

① **Connect the audio source that you want to input.**

- **Input from the AUDIO INPUT 1 and 2 jacks**
Connect a mic, guitar, or CD player etc. to the rear panel AUDIO INPUT 1 and 2 jacks.

Set the AUDIO INPUT [MIC/LINE] switch as appropriate for the device you are inputting.

If a mic is connected, set this to the **MIC** position.

If a guitar or analog audio device is connected, set this to the **LINE** position.

note Guitars with active pickups can be input directly. However if your guitar has a passive-type pickup (i.e., without a built-in preamp), the mismatch in impedance levels will make it difficult to sample at an appropriate level. Such instruments should be routed through a preamp or effect unit before they are connected.

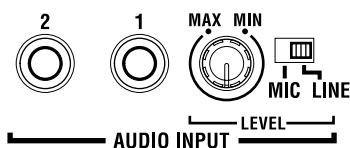

- **Input from the S/P DIF IN jack**
Connect the optical digital output jack of your DAT etc. to the rear panel S/P DIF IN jack. (☞ PG p.138)

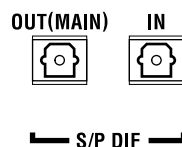

- **Input from the mLAN connector (if the EXB-mLAN option is installed)**
Connect the IEEE 1394 connector ("FireWire" style) of your mLAN device or computer to the rear panel mLAN connector.

☞ Refer to the owner's manual of the EXB-mLAN option.

Input settings

One set of *Input* settings are maintained by Sampling mode, and a different set of Input settings are shared by Combination, Program, Sequencer, Song Play, and Disk mode. This latter set is saved as Global mode parameters. Normally you will set these in Global mode; however, these same settings can also be made from the other modes.

These settings can be made in the following pages.

Mode	Page
Sampling	Sampling P0: Recording, Input/Setup
Combination,	Combination P0: Play, Sampling
Program,	Program P0: Play, Sampling
Sequencer,	Sequencer P0: Play/REC, Sampling
Song Play,	Global P0: Basic Setup, Input/Sampling
Disk	Disk, Play Audio CD

note Sampling can be performed in Sampling, Combination, Program, and Sequencer modes.

② **Select the page for making *Input* settings.**

As an example, here's how to make settings in Sampling mode and in Program mode.

- **Sampling mode**

Press the [SAMPLING] key to enter Sampling mode. Press the Input Setup tab to access the P0: Recording, Input/Setup page.

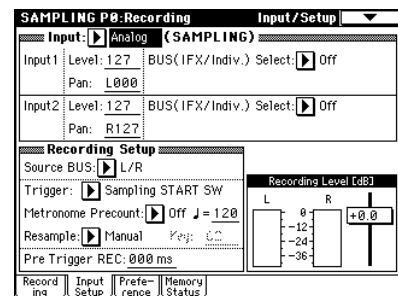

- **Program mode**

Press the [PROG] key to enter Program mode. Press the Sampling tab to access the P0: Play, Sampling page.

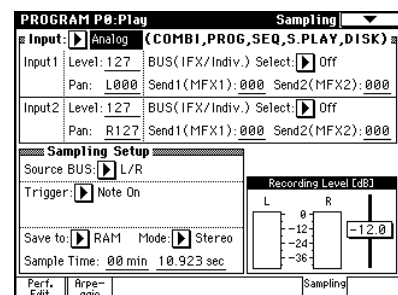

③ **Use "Input" to select the input source.**

If you want to sample the input from the AUDIO INPUT 1 and 2 jacks, set "Input" to **Analog**.

If you want to sample the input from the S/P DIF IN jack, set "Input" to **S/P DIF**.

If you want to sample the input from the mLAN connector, set "Input" to **mLAN** (selectable if the EXB-mLAN option is installed).

- ⚡ If “Input” is set to S/P DIF or mLAN, an “Obey Copyright Rules” dialog box will appear. Carefully read “About copyright” (p.iii), and if you accept the terms, press the OK button to continue with settings. If you do not accept the terms, press the Cancel button to cancel the setting.



- note If you want to sample analog audio from an audio CD inserted in the CDRW-1 option, set “Input” to Analog, and adjust the “Level” etc.
- ④ For *Input1* and *Input2*, set “BUS (IFX/Indiv.)” to specify the destination to which the external audio signal you selected in “Input” will be sent.

L/R: Send to the L/R bus.
 IFX1–IFX5: Send to the corresponding insert effect.
 1–4, 1/2, 3/4: Send to the INDIVIDUAL 1–4, 1/2, or 3/4 bus(es).

Use “Level” to adjust the signal level. Normally you will set this to 127. Use “Pan” to specify the stereo position.

In the Input section (COMBI, PROG, SEQ, S.PLAY, DISK) you can specify the send levels “Send1 (MFX1)” and “Send2 (MFX2)” to master effects 1 and 2.

These settings can be made if “BUS (IFX/Indiv.)” is L/R or Off.

- ⚡ “Send1 (MFX1)” and “Send2 (MFX2)” cannot be set in Sampling mode.
- The input from the AUDIO INPUT 1 jack is set by *Input1*, and the input from the AUDIO INPUT 2 jack is set by *Input2*.
- The L channel of the input from the S/P DIF IN jack is set by *Input1*, and the R channel is set by *Input2*.
- Of the input from the mLAN connector, mLAN1 is set by *Input1*, and mLAN2 is set by *Input2*.

Example:

Send the signal from the AUDIO INPUT 1 jack in mono to the L/R bus

Input1 “BUS (IFX/Indiv.)” L/R, “Level” 127, “Pan” L000

Example:

Send the signal from the AUDIO INPUT 1 and 2 jacks in stereo to the L/R bus

Input1 “BUS (IFX/Indiv.)” L/R, “Level” 127, “Pan” L000

Input2 “BUS (IFX/Indiv.)” L/R, “Level” 127, “Pan” R127

- ⚡ When “BUS (IFX/Indiv.)” is changed from Off to L/R or IFX, please be aware that the volume level of the AUDIO OUT L/MONO and R jacks and the headphones may rise excessively.

2. Setting the recording level (Recording Level [dB])

- ① Produce sound at the volume that you want to record.

If you are inputting from the AUDIO INPUT 1 and 2 jacks, gradually turn the [LEVEL] knob from the MIN position toward MAX. Set the level immediately below the point where the display indicates “ADC OVERLOAD !!” (AD converter input overload).

- note The best audio quality will be obtained at a level immediately below the point where “ADC OVERLOAD !!” is displayed (i.e., the highest level that does not produce an overload).

- ② Press the SAMPLING [REC] key.

Produce sound at the volume that you want to record. Watch the level meters to check the input volume.

Use the “Recording Level” slider to adjust the recording level.

- ⚡ The output volume will not change at this time, but your adjustment will affect the data that will be sampled.

If “CLIP!!” is displayed, lower the “Recording Level” (located at the right of the display) to an appropriate level.

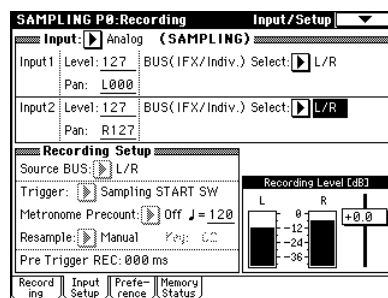

We recommend that you set the “Recording Level” as shown below, depending on whether you are sampling only an external input source, or resampling the playback of a song or a performance played on a program, combination, or sample.

At this time you can also set “Auto +12 dB On” (p.105) so that the recorded sample will play back at an appropriate level.

When sampling only an external input source:

“Recording Level”: +0.0 (dB)

“Auto +12 dB On”: off (unchecked)

When resampling (sampling the playback of a song, or your keyboard performance using a program, combination, or sample)

When simultaneously resampling and sampling an external audio source:

“Recording Level”: -12.0 (dB)

“Auto +12 dB On”: on (checked)

(p.105 “The recording level and “Auto +12 dB On””)

- ③ When you have finished making adjustments, press the SAMPLING [REC] key.

3. Specifying the recording method (Recording Setup/Sampling Setup)

① In “Source BUS,” select the source that you want to sample.

The sound being sent to the bus you select here will be sampled.

L/R: The sound being sent to the L/R bus will be sampled.

Indiv.1/2: The sound being sent to the Individual 1, 2 bus will be sampled.

For examples of these settings, refer to the various examples of sampling. (p.37, 43, 45, 47, 115)

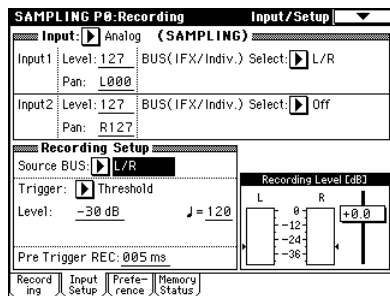

② Use “Trigger” to specify how sampling will begin.

The available trigger methods will differ depending on the mode.

Sampling mode:

Sampling START SW, Note On, Threshold

Program, Combination modes:

Sampling START SW, Note On

Sequencer mode:

Sampling START SW, Note On, Threshold, Sequencer START SW

Here we will describe the Sampling START SW and Note On that can be used in all modes. For details on trigger methods suitable for various purposes, refer to the various examples of sampling on p.38, 43, 45, 47, 115 or PG p.4, 37, 56, and 97.

Sampling START SW: When you press the SAMPLING [REC] key, you will enter sampling-standby mode, and sampling will begin when you press the SAMPLING [START/STOP] key.

Note On: When you press the SAMPLING [REC] key and then the SAMPLING [START/STOP] key, you will enter sampling-standby mode, and sampling will begin when you play the keyboard.

4. Making settings for the sample to be recorded (REC Sample Setup/Sampling Setup)

Next we will specify the location into which the data will be sampled, select mono or stereo sampling, and specify the sampling time.

REC Sample Setup settings are made in Sampling mode, and Sampling Setup settings are made in Combination, Program, or Sequencer mode. These settings are maintained independently for each mode.

Use the following pages to set them.

Mode	Page
Sampling	Sampling P0: Recording, Recording
Combination	Combination P0: Play, Sampling
Program	Program P0: Play, Sampling
Sequencer	Sequencer P0: Play/REC, Sampling

• **Sampling mode**

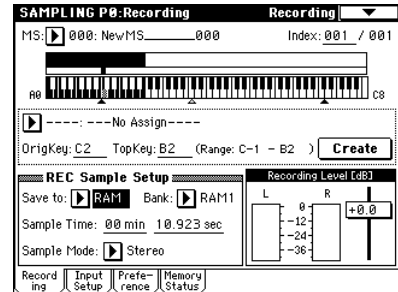

• **Program mode**

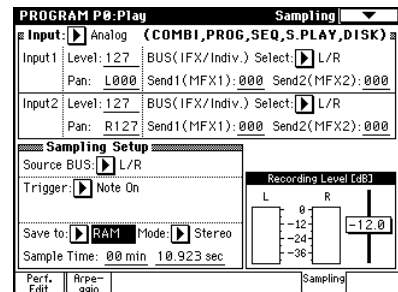

① Use “Save to” to specify the location into which the data will be sampled.

RAM: The sample will be written into sample memory (RAM).

If you select RAM, you can also specify the writing-destination RAM bank.

In Sampling mode, this is specified by “Bank.”

In other modes, this is specified by the page menu command “Select Bank & Smpl No.”

When you select “Select Bank & Smpl No.,” the following dialog box will appear.

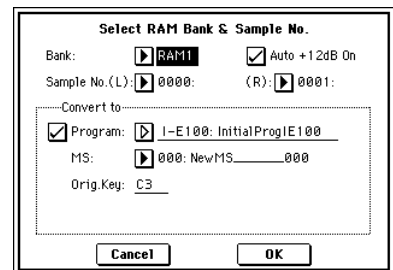

Specify the “Bank” in this dialog box.

“Sample No.” specifies the writing-destination sample number. If “Sample Mode” is set to Stereo, specify L and R.

If you check “Program” in the “Convert to” area, the sample will automatically be converted to a program immediately after the sample has been written into RAM. This is convenient when you want to hear the sampled sound immediately.

At the right, use “Program” and “MS” to specify the program number and multisample number of the program that will be created by the conversion.

Use “Orig.Key” to specify the key that will play the sample at its original pitch. “Orig.Key” will increment

by one after you sample, so that the next sample you record will be assigned to the next higher note. Press the OK button to finalize the settings.

note Set the “Auto +12 dB On” parameter. If you check “Auto +12 dB On,” the sample playback level will automatically be increased by +12 dB after sampling. (☞ “The recording level and “Auto +12 dB On””) In Sampling mode, you can set this parameter in the P0: Recording, Preference page.

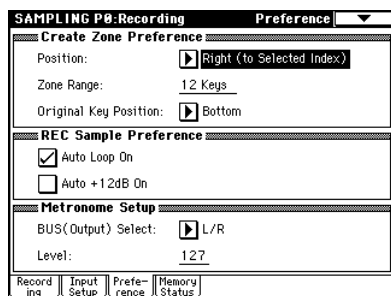

In Program, Combination, and Sequencer modes, you can set this parameter using the Sampling page menu command “Select Bank & Smpl. No.” (☞ p.104).

DISK: The sample will be written to the internal hard drive or a SCSI-connected hard disk drive etc.

If you select DISK, you can also select the writing-destination drive.

In all modes, this is specified by the page menu command “Select Directory.”

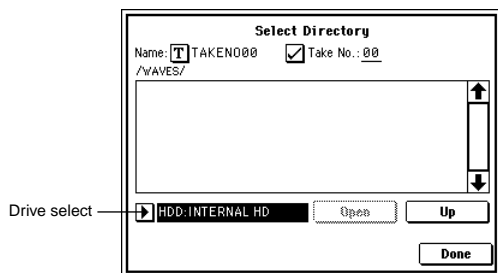

In the drive select field, select the drive. Use the Open and Up buttons to move between levels of the directory hierarchy to select the desired directory. Press the Done button to finalize the settings.

note If you sampled to the internal hard disk etc. as a WAVE file, the “Auto +12 dB On” setting will be ignored. The playback level of the WAVE file is set by “WAVE File Play Level” (☞ PG p.138).

② In “Sample Time,” specify the length of time that you want to sample.

This can be set in units of minutes and seconds. If you are sampling to RAM (sample memory), you can sample a maximum of approximately 2 minutes 54 seconds in mono, or approximately 1 minute 27 seconds in stereo. If you have installed additional SIMM boards to expand the sample memory to 96 Mbytes, you will be able to sample up to six samples of 2 minutes 54 seconds each in mono (or approximately 1 minute 27 seconds in stereo), for a total of 17 minutes 28 seconds (or approximately 8 minutes 44 seconds in stereo).

If you are sampling to DISK, you can sample a maximum of 80 minutes in either mono or stereo (mono: approximately 440 Mbytes, stereo: approximately 879 Mbytes).

③ Set “Sample Mode” to specify whether a mono or a stereo file will be created.

L-Mono: The sound of the internal L channel will be sampled in mono.

R-Mono: The sound of the internal R channel will be sampled in mono.

Stereo: The sound of the internal L and R channels will be sampled in stereo.

The recording level and “Auto +12 dB On”

When you resample the playback of a song, or your keyboard performance using a program, combination, or sample, or if you mix your performance with an external audio source and sample the result, you should normally set “Recording Level” to -12.0 (dB). If you resample at -12.0 (dB), the sample data will be recorded at the optimum level, but the playback level will be lower than the level during sampling (if “+12 dB” is off). In such cases, you can check “Auto +12 dB On” when you resample, so that “+12 dB” (Sampling mode Loop Edit page) will automatically be turned on, and the recorded sample will play back at the same level at during resampling.

When you sample an external audio source, you should normally set “Recording Level” to +0.0 (dB). The sample data will be recorded at the optimum level. If you sample with “Auto +12 dB On” turned off at this time, “+12 dB” (Sampling mode Loop Edit page) will be off, and the sample will play back at the same level at which it was sampled.

When the power is turned on, “Recording Level” and “Auto +12 dB On” will default to the following settings.

Program, Combination, Sequencer modes

“Recording Level”: -12.0 (dB), “Auto +12 dB On”: on
Sampling mode

“Recording Level”: +0.0 (dB), “Auto +12 dB On”: off
These settings assume that you will mainly be resampling in Program, Combination, and Sequencer modes (listed above), and performing conventional sampling in Sampling mode (listed below).

Optimizing the sample memory (RAM)

If RAM has been specified as the destination to which data will be written during sampling, you can specify that sample memory (RAM) be automatically optimized after the data is written. When optimization is performed, unused areas that are occupying memory space will be reorganized to increase the available free space. In the Global mode P0: Basic Setup, Input/Sampling page, you can check “Auto Optimize RAM” so that RAM will automatically be optimized when sampling ends. In this case, you will always be able to sample without any wasted RAM area, but the sound will stop for a time when sampling ends. If a song is being played back in Sequencer mode, the playback will stop.

If you are playing back a song, or if you are repeatedly recording multiple samples in various locations while listening to audio input from a CD etc., you can sample with “Auto Optimize RAM” unchecked, and then execute the page menu command “Optimize RAM” (found in the Sampling page of Program, Combination, or Sequencer modes, and in P0–P4 of Sampling mode) to optimize the RAM when the remaining amount of memory begins to decrease. The remaining amount of sample memory (RAM) can be checked in Sampling mode P0: Memory Status.

Sampling and editing in Sampling mode

In Sampling mode, you can record samples, and edit sample data that you sampled or loaded from media (including WAVE and AIFF formats). You can also assign the edited samples to indexes (zones) to create a multisample.

For an example of sampling, refer to p.37-.

Here we will explain sampling operations that are specific to Sampling mode, and how to edit a multisample or sample.

Creating multisample indexes and sampling

Here's how to create indexes for a multisample, and how to assign a sample to each index.

- 1 Select the P0: Recording, Recording page.

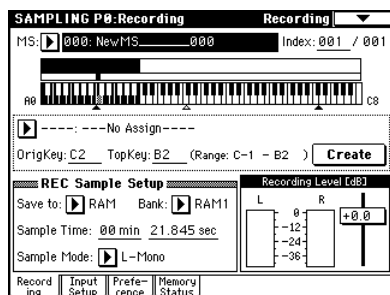

- 2 Select "MS (Multisample Select)," and create a multisample.

To create a new multisample, press the "MS (Multisample Select)" popup button. Then press a Multisample No. in the list for which no name has been entered, or use the numeric keys [0]–[9] to input a number and then press the [ENTER] key.

A dialog box will appear.



If you want to create a stereo multisample, check the "Stereo" box, and press the OK button.

If you want to create a monaural multisample, uncheck the "Stereo" box, and press the OK button.

- 3 Press the Create button to create an index.

Immediately after the power is turned on, the "Index" will be indicated as 001/001. This means that there is only one index.

The range that is highlighted in the keyboard & Index is the range of the selected index.

Press the Create button several times. Each time you press it, an index will be created. The keyboard display will indicate the zone and original key location of each index.

note The index that is created when you press the Create button will be created according to the P0: Recording, Preference page *Create Zone Preference* settings. (These settings can also be made in P3: Multisample, Preference page *Create Zone Preference*. PG p.99, 119)

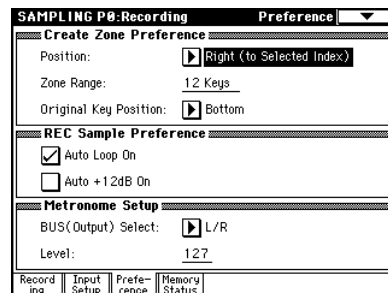

Immediately after the power is turned on, "Position" will be **Right** (to selected index), "Zone Range" will be **12 Keys**, and "Original Key Position" will be **Bottom**, so that indexes will be created as shown below.



note If you set "Zone Range" to 1 Key, an index will be created for each note of the keyboard. It is convenient to use 1 Key when you wish to sample numerous takes in succession, such as when recording phrases or rhythm loops.



- 4 Select "Index."

"Index" can also be selected by holding down the [ENTER] key and playing a note on keyboard. For this example, select 001.

- 5 Assign a sample to the "Index."

If sample memory (RAM) already contains samples, use "Sample Select" to select the sample and assign it.

If you want to record a new sample, you can sample it now.

The sample you record will be automatically assigned to the index you selected in step 4.

The assigned sample will sound when you play the keyboard in the range of the index to which the sample is assigned.

- 6 Repeat steps 4 and 5 to assign a sample to each index.

note The number and order of the indexes in a multisample, the range of each index, and the original key position can be freely changed later if desired. ("Multisample editing" p.111)

Creating multiple samples

In the example procedure described above, several indexes were created (by pressing the Create button several times), and then samples were assigned to each "Index."

As an alternative method, it is also possible to create one index, sample into it, and then repeat these two steps.

- 1 Press the Create button once to create an index.

② Record a sample.

The recorded sample will automatically be assigned to the index you created in step ①.

③ Repeat steps ① and ②.

This is an efficient way to record multiple samples. (p.39)

Applying an insert effect to a sample and resampling it

The process of applying an insert effect etc. to a sampled sound and then sampling it once again is called “resampling.”

① In the P0: Recording, Recording page, assign the sample that you want to resample to “Sample Select.”

When the power is first turned on, the assigned sample will be set to “Orig.Key” C2.

If you want to resample in stereo, set “Sample Mode” to Stereo.

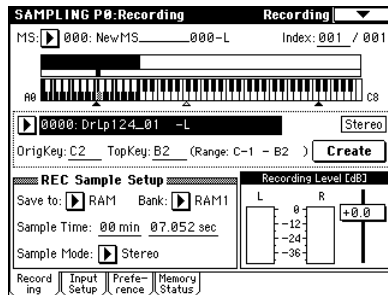

② In P2: Loop Edit, check the “+12 dB” setting.

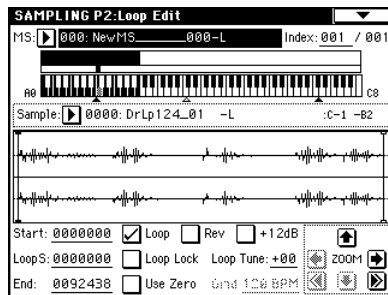

By making the following settings, you will be able to resample at the optimal level.

If “+12 dB” is not checked:

- “Recording Level”: +0.0 (dB)
- (P0: Recording, Recording page)
- “Auto +12 dB On”: Off (unchecked)
- (P0: Recording, Preference page)

If “+12 dB” is checked:

- “Recording Level”: -12 dB (dB)
- (P0: Recording, Recording page)
- “Auto +12 dB On”: Off (checked)
- (P0: Recording, Preference page)

③ In the P0: Recording, Input/Setup page, set “Resample” to Auto.

Use “Key” to specify the sample that will be resampled. Set this to C2.

Since we will not be sampling from an external input, set “BUS (IFX/Indiv.) Select” to Off for each Input.

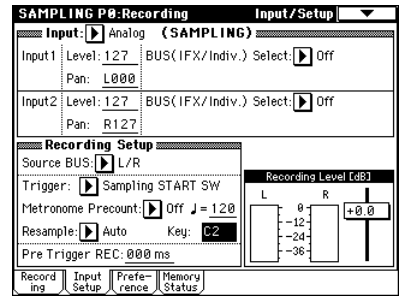

④ In the P8: Insert Effect, Routing page, set “BUS (IFX) Select” to IFX1.

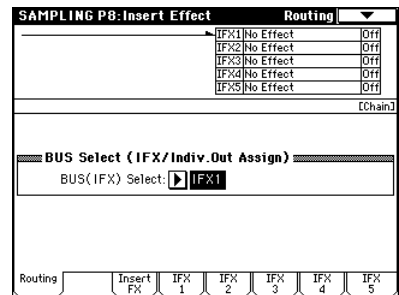

⑤ In the P8: Insert Effect, Insert FX page, set “IFX1” to 052: Reverb Hall, and turn “IFX On/Off” ON.

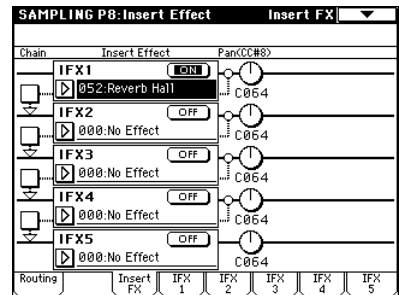

Press the C2 key, and verify that reverb is applied.

⑥ Press the SAMPLING [REC] key, and then the SAMPLING [START/STOP] key.

The sample that is assigned to C2 will play back, and resampling will start. When the sample finishes playing, resampling will end.

The sample that was created by resampling will automatically be assigned to “Sample Select.”

⑦ Press the C2 key, and verify that reverb is applied.

In Sampling mode, the P8: Insert Effect, Routing page “BUS (IFX) Select” parameter will automatically be set to L/R when resampling ends. This prevents an insert effect from being applied in duplicate when you monitor the results of resampling through an insert effect.

If you want to apply an insert effect once again, re-select IFX1.

note As an alternative to automatically resampling as described above (“Resample” Auto), you can simply sample the sounds that you play from the keyboard (“Resample” Manual).

In "Sample Select," assign the sample that you will resample, and set "Resample" to Manual. Set "Trigger" to Note On, and set "Sample Mode" to Stereo as desired. Then set the bus and effect as described in steps ③ and ④, press the SAMPLING [REC] and then the [START/STOP] key, and then press the C2 key to start resampling. When you want to stop resampling, press the SAMPLING [START/STOP] key.

Ripping

Digital data from an audio CD inserted in the CDRW-1 option or a SCSI-connected CD-ROM or CD-R/RW drive can be sampled in the digital domain. This process is known as "ripping."

You can either read the audio CD playback from the AUDIO INPUT as analog audio, or directly read it as digital data.

▲ In order to perform this operation, you must either install the CDRW-1 option, or connect an external CD-ROM or CD-R/RW drive to the SCSI connector. For details on installing the CDRW-1, refer to PG p.286. For details on SCSI connections, refer to PG p.298. If you are using a SCSI-connected CD-ROM or CD-R/RW drive, use audio cables to connect the audio outputs of the drive to the TRITON STUDIO's AUDIO INPUT 1 and 2.

Ripping digital data from an audio CD as a sample

Here's how digital data from an audio CD track can be captured as a sample.

- ① **Insert an audio CD into the CDRW-1 option or a SCSI-connected CD-ROM or CD-R/RW drive.**
- ② **In the Sampling mode P0: Recording, Input/Setup page, make Input settings so that you can monitor the audio that you want to rip.**

"Input": Analog

Input1 "BUS (IFX/Indiv.)" L/R, "Level" 127, "Pan" L000

Input2 "BUS (IFX/Indiv.)" L/R, "Level" 127, "Pan" R127

note Ripping will not be affected by these inputs.

- ③ **Access the Sampling mode P5: Audio CD, Ripping page.**
- ④ **In "Drive" (drive select), select the drive that contains the audio CD, and use "Track" to select the track that you want to rip.**
Raise the "Volume."

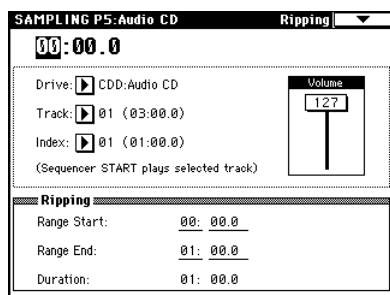

- ⑤ **Press the SEQUENCER [START/STOP] key to play back the audio CD track.**

- ⑥ **During playback, press the [ENTER] key at the points where you want ripping to begin and end.**

This will set "Range Start" and "Range End."

If you press the [ENTER] key three or more times, "Range Start" and "Range End" will respectively be set to the next-to-last point at which you pressed the key, and the last point at which you pressed the key.

note The method described above is used when the cursor is located at other than "Range Start" or "Range End."

If the cursor is located at "Range Start" or "Range End," that setting will be re-set each time you press the [ENTER] key.

note If the cursor is located at "Range Start" or "Range End," this region will be played back.

When you finish making settings, press the SEQUENCER [START/STOP] key to stop playback of the audio CD.

- ⑦ **Verify the region that will be ripped.**

Select either "Region Start" or "Region End" (the display will be highlighted), and press the SEQUENCER [START/STOP] key. The CD will play from "Range Start" to "Range End" and then stop.

note If you want to adjust the location, use the VALUE controllers to modify the "Range Start" or "Range End" settings, or move the cursor to a parameter other than "Range Start" and "Range End" and repeat step ⑤ to make the setting once again.

If you want to move the track playback start location to the beginning of the track, press the [LOCATE] key.

- ⑧ **When you have finished setting "Range Start" and "Range End," select the page menu command "Destination."**

A dialog box will appear.

Specify the destination to which the ripped sample will be written.

Select RAM if you want to rip the sample into sample memory (RAM). In this case, you can also set Sample No. (L), (R) to specify the sample number that will be written. Normally you can leave this unchanged.

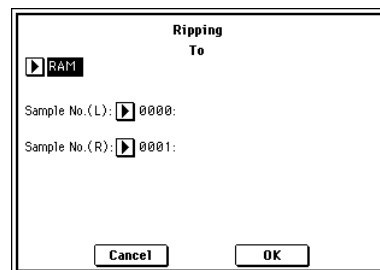

Select **DISK** if you want to rip the sample to hard disk. Use drive select to select the drive, and use the Open and Up buttons to select the directory in which the data will be saved. Also specify a name for the WAVE file that will be saved.

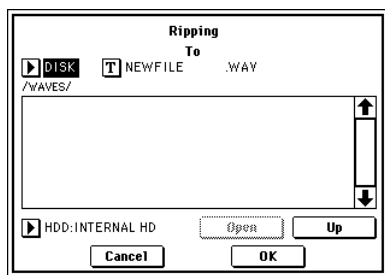

- 9 Press the **OK** button to execute ripping, or press the **Cancel** button to cancel without executing.

When you press the **OK** button, the "Obey Copyright Rules" dialog box will appear. Carefully read "About copyright" (esp.iii), and if you consent to the terms, press the **OK** button to begin ripping. If you do not consent to the terms, press the **Cancel** button to cancel the operation.



Reading the analog audio output of an audio CD into a sample

Here's how analog audio data from an audio CD track can be loaded into a sample.

In the same way as when you send the audio output of a CD player to the TRITON STUDIO's AUDIO INPUT 1 and 2, use audio cables to connect the audio outputs of your SCSI-connected CD-ROM or CD-R/RW drive to the TRITON STUDIO's AUDIO INPUT 1 and 2.

You can use the TRITON STUDIO's SEQUENCER [START/STOP] key etc. to control operations such as playback and stop on your CD-ROM or CD-R/RW drive.

When using the CDRW-1 option, the analog output can be internally connected to AUDIO INPUT 1 and 2, so it is not necessary to make connections using audio cables.

- 1 If you are using a SCSI-connected CD-ROM or CD-R/RW drive, use audio cables to connect its audio outputs to the TRITON STUDIO's AUDIO INPUT 1 and 2.
- 2 Insert an audio CD.
- 3 Access the Sampling mode P5: Audio CD, Ripping page.
- 4 Use "Drive" (drive select) to select the drive that contains the audio CD, and use "Track" to select the track that you want to read.
Raise the "Volume."

Some SCSI-connected CD-ROM or CD-R/RW drives cannot be controlled in this way, so this setting may not affect the volume.

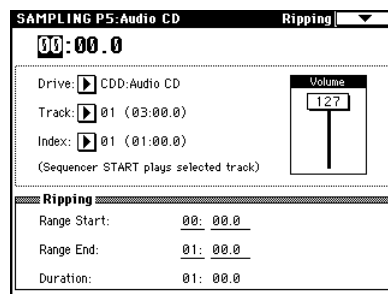

- 5 In the P0: Recording, Input/Setup page, make **Input** settings as follows.

"Input" Analog

Input1 "Level" 127, "Pan" L000, "BUS Select" L/R
Input2 "Level" 127, "Pan" R127, "BUS Select" L/R

- 6 Specify the recording method in **Recording Setup**.

"Source BUS" L/R

"Trigger" Sampling START SW

Sampling will start when you press the SAMPLING [START/STOP] key.

"Resampling" Manual

- 7 In **REC Sampling Setup**, make settings for the sample that will be recorded.

"Save to" RAM: if you want to write the sample into sample memory (RAM)

"Save to" DISK: if you want to write the sample to hard disk

"Sample Mode" Stereo

"Sample Time" maximum

- 8 Adjust the recording level.

Press the SAMPLING [REC] key.

When you press the SEQUENCER [START/STOP] key to play back the audio CD, the level meter will indicate the volume that will be sampled. If the display indicates "ADC OVERLOAD !," adjust the "Volume" in the P5: Audio CD, Ripping page.

If you are using an external SCSI drive, you can also make adjustments using the volume control of the drive, or the rear panel [LEVEL] knob.

If the display indicates "CLIP!," use the VALUE controllers to lower the "Recording Level" slider below +0.0 until an appropriate level is reached.

When you finish making adjustments, press the SEQUENCER [START/STOP] key to stop playback of the audio CD. Press the [LOCATE] key to return the location to the beginning of the track.

Press the SAMPLING [REC] key once again.

- 9 Execute sampling.

Press the SAMPLING [REC] key.

Press the SEQUENCER [START/STOP] key to start playback of the audio CD track.

At a point slightly earlier than where you want to sample, press the SAMPLING [START/STOP] key to begin sampling.

At the point where you want to stop sampling, press the SAMPLING [START/STOP] key to stop sampling.

Loop settings

Using the default settings after the TRITON STUDIO is first turned on, the sounds you sample will automatically be looped (P0: Recording, Preference page “Auto Loop On” On)

To edit the loop and other playback address settings for the sample, use the P2: Loop Edit page.

- 1 Select the sample for which you wish to make loop settings.

To select the sample, use the “Sample Select” or “Index” parameters of P2: Loop Edit page or of the P0: Recording, Recording page. (☞p.106)

- ▲ If you use “Sample Select” to select the sample, be aware that the assignment to the index will also change.

- 2 In the P2: Loop Edit page, use the “Loop” check box to turn loop playback on/off for the sample.

Looping will be turned on if the box is checked. This will operate between the addresses you specify in step 3.

Loop On: Start→End→LoopS→End→ (LoopS→End is repeated)

Loop Off: Start→End

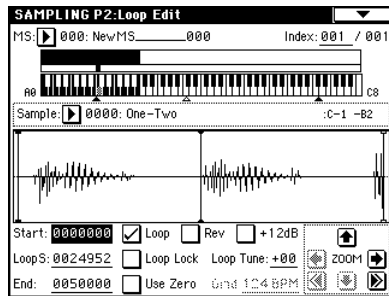

To play the sample, press the key to which the sample is assigned (the key range that is highlighted in “Keyboard & Index”).

- note A sample waveform that was sampled with “Sample Mode” set to Stereo will be displayed in two levels. The upper level is the L channel, and the lower level is the R channel.

- 3 Specify the start address in “Start,” the loop start address in “LoopS (Loop Start),” and the end address in “End.”

Select “Start” (highlighted), and use the [VALUE] dial or other VALUE controllers to modify the value. The corresponding vertical line will move. Set “LoopS (Loop Start)” and “End” in the same way. In the example shown below, “Start” is set immediately before the first waveform, “LoopS (Loop Start)” is set immediately before the second waveform, and “End” is set as desired.

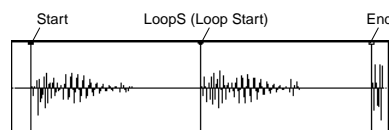

- note By using the ZOOM button you can change the range that is displayed. When “S (Start)” is highlighted, zoom will be performed from the start address (☞PG p.100).

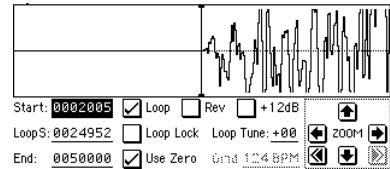

- note If the “Use Zero” check box is checked, only those addresses where the waveform data crosses the zero level will be found automatically when searching, and can be set. This lets you easily make address settings where noise is less likely to occur when looping.

- 4 If necessary, use the page menu command “Truncate” to delete unwanted data that falls outside the start (or loop start) and end addresses.

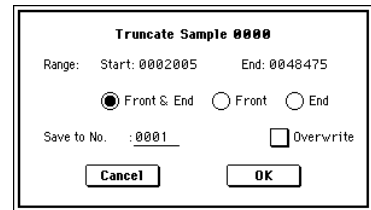

Set the parameters, and press the OK button to execute the operation. (☞PG p.101)

- ▲ For cautions on the “Save to No.” and “Overwrite” check boxes, refer to “About “Overwrite”” (☞PG p.101).

The grid display

The page menu command “Grid” overlays the waveform display with a grid based on the BPM tempo value. This makes it easy to make loop settings that are synchronized to the tempo.

- note In the same way, the grid display can also be used in P1: Sample Edit page. The grid can help you to edit the waveform in sync with the tempo.

- 1 Select the page menu command “Grid”.

The following dialog box will appear.

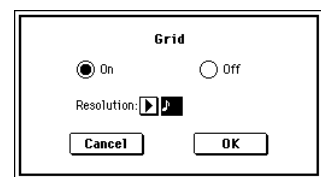

Turn “Grid” On, set the desired “Resolution,” and press the OK button. Dotted grid lines will appear.

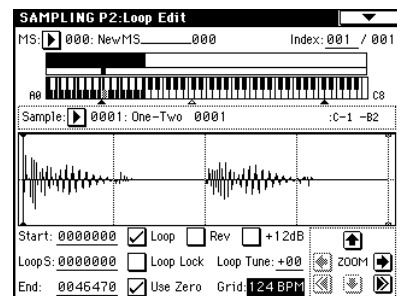

- 2 Set “Grid” to the desired BPM tempo value.
- 3 Set the end address so that it coincides with a dotted line of the grid.

This will cause the loop interval to be the same length as the BPM value.

The grid display will be based at “LoopS (Loop Start)” if looping is on. If looping is off, the grid will be based at “Start.”

- ④ **To hide the grid display, select the page menu command “Grid,” uncheck “Grid,” and press the OK button.**

note The grid is displayed according to the playback pitch of the base key (the key shown in gray in the “Keyboard & Index” area).

You can select the base key by holding down the [ENTER] key and playing a note on the keyboard.

Sample (waveform data) editing

Editing the waveform data of the sample is done in P1: Sample Edit. You can use commands such as cut, copy, and normalize to edit the waveform data.

- ① **Select the sample that you wish to edit.**

Use “Sample Select” or “Index” in the P1: Sample Edit page or the P0: Recording, Recording page to select the sample. (☞p.106)

- ▲ If you use “Sample Select” to select the sample, be aware that the index assignment will also change.

- ② **Select the P1: Sample Edit page.**

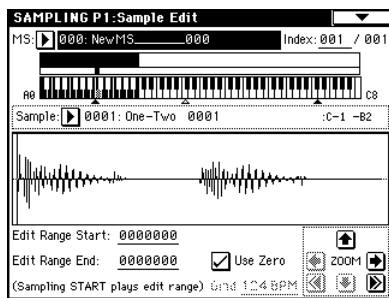

The waveform data of the currently selected sample will be displayed.

note Sample waveforms that were recorded with a “Sampling Mode” of Stereo will be shown in two lines. The upper line is the L channel waveform, and the lower line is the R channel waveform.

- ③ **Use “Edit Range Start” and “Edit Range End” to specify the range that you wish to edit.**

The selected range will be highlighted.

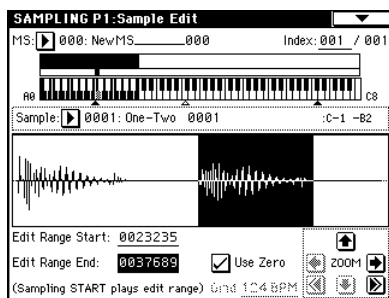

If you wish to hear the sound of the selected range, press the SAMPLING [START/STOP] key. The selected range will play back at the pitch of the base key (the key shown in gray on the keyboard display). You can select the base key by holding down the [ENTER] key and playing a note on keyboard.

When you play a key to which the sample is assigned (the highlighted range of the keyboard displayed in “Keyboard & Index”), the sample will be played back according to its loop settings.

note The procedure for using the ZOOM and “Use Zero” check boxes is the same as for P2: Loop Edit.

- ④ **From the list of page menu, select the desired editing command. Make the appropriate settings in the dialog box, and press the OK button to execute.**

For details on each command (☞PG p.101).

A note on saving samples

In the dialog boxes of some page menu, there is a “Save to No.” setting that lets you specify the sample number to which the edited sample will be saved. At this time, a vacant sample number will be selected automatically, so you will change the setting only if you want to specify the save destination number.

If you check “Overwrite” in the dialog box of the command, the data prior to editing will be deleted, and will be overwritten by the edited data. Normally, you will execute the Write operation without checking this, so that the unedited data is preserved. When you are completely finished with your editing, you can use the page menu command “Delete Sample” to delete unneeded samples.

▲ In Sampling mode, there is no Compare function that lets you compare the data before and after editing. If you wish to preserve the unedited state of the multisample or sample, use “Copy Sample” or “Copy MS” (☞PG p.92, 93) to copy the multisample or sample before you begin editing it. For some page menu commands in P1: Sample Edit or P2: Loop Edit, you can execute without checking the “Overwrite” setting in the dialog box, so that the sample data previous to editing will be preserved.

Multisample editing

Editing a multisample is accomplished with a number of operations i.e. creating indexes for the multisample and assigning a sample to each index, editing operations such as deleting, copying, and inserting indexes, and detailed settings such as sample level and pitch for each index. Multisample editing is performed in P3: Multisample.

note Basic settings such as creating indexes and assigning samples can also be made in the P0: Recording, Recording page.

Editing the indices

To change the number or order of the indexes, use the Insert, Cut, Copy, and Create buttons.

① Select the P3: Multisample.

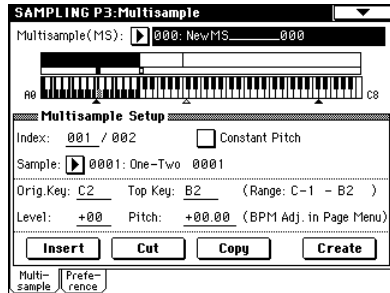

② Use “Multisample (MS)” to select the multisample that you wish to edit.

③ Select the “Index.”

You can also select an index by holding down the [ENTER] key and playing a note on the keyboard.

④ Press the buttons to modify the number or order of the indices, and edit them.

To delete the selected index, press the Cut button. The Insert button is used in conjunction with the Cut and Copy buttons. The contents of the index that was Cut or Copied will be inserted. The Create button has the same function as the Create button in P0: Recording (“Creating multisample indexes and sampling” p.106).

Modifying the settings of an index

① Make the settings described in steps ①–③ of “Editing the indexes.”

② Set parameters for the selected index.

(p.117)

- Changing the “Top Key” will change the upper limit of the zone. Simultaneously, the lower limit of the next-numbered index will also change.
- If you check “Constant Pitch,” all notes in the index zone will sound the sample at its original pitch.
- “Pitch” adjusts the sample pitch for each index. You can use the “Pitch BPM Adjust” page menu command to set the loop interval to a desired BPM value (p.118).

Converting a multisample to a program

In pages P0: Recording–P4: Controller Setup, you can select and execute the “Convert MS To Program” page menu command. When you execute this command, the settings of the currently selected multisample will be converted into a program. In Program mode you can make filter, amp and effect settings etc., and play the sample as a program. The resulting program can be used in a combination or song.

For details on the “Convert MS To Program” page menu command (p.41, PG p.93).

Using samples in a drum kit

A sample you created in Sampling mode can be used as one of the instruments in a drum kit. In the Global P5: Drum Kit, Sample Setup page and Low Sample page, set “Drumsample Bank” to RAM, and use “Drumsample” to select the sample that you created.

Using Time Slice to divide a sample, and playing it in Sequencer mode

Time Slice is a function that detects the attack of the kick or snare etc. in a rhythm loop sample (a sample consisting of a looped pattern of drums etc.), and automatically divides it into separate instrumental sounds. Each of the divided instrumental sounds is made into a sample of its own, and then automatically expanded into a multisample and program. Pattern playback data for the Sequencer mode using the divided samples is also created automatically.

The time-slices sample can be used in the following ways by the song of Sequencer mode.

- Multiple rhythm loop samples of differing tempo can be matched to the same tempo without changing their pitch.
- You can change the tempo in realtime without affecting the pitch.

As an example, we will describe how a rhythm loop sample can be time-sliced in Sampling mode, and then how the rhythm loop sample can be played in Sequencer mode.

You will need to provide rhythm loop samples of drums etc. You can either record these on the TRITON STUDIO, or load them in Disk mode. Initially, you should try this using a one-measure pattern in 4/4 time with a fairly simple beat, and record the pattern as a mono rhythm loop sample.

For this example, we will use a 120 BPM rhythm loop sample.

① Select “Sample Select” 120 BPM rhythm loop sample.

note Play back the sample, and verify that the beats that you want to loop are played cleanly. If they are not played cleanly, make the appropriate settings for the start address “Start” and end address “End,” and execute the page menu command “Truncate” (p.44, 110).

② Access the P2: Loop Edit page.

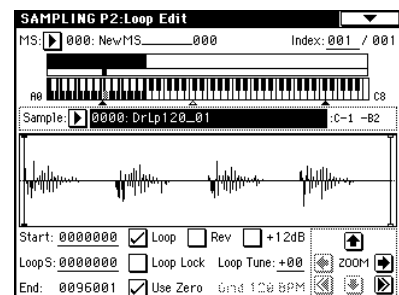

- ③ Select the page menu command “Time Slice.”

The Set Sample Tempo dialog box will appear.

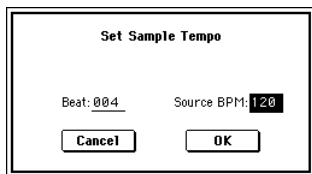

- ④ Specify the number of quarter-note beats in the sample, and its tempo.

If you know the BPM, set “Source BPM.”
If you do not know the BPM, set “Beat” and the BPM will be calculated automatically. Since in this example we know the beat, set “Source BPM” to 120.

- ⑤ Press the OK button.

The sample will automatically be sliced, and a dialog box will appear.

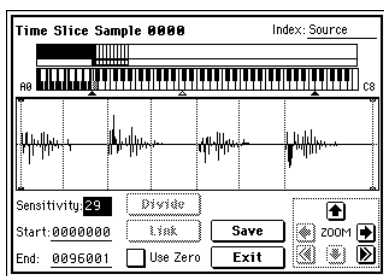

When you play the keyboard, C2 will play the original sample (Source), and D2 and subsequent keys will play the divided samples.

While listening to each divided sample, adjust “Sensitivity” so that each drum strike or other rhythm instrument sound is divided into its own sample. In some cases, it may not be possible to slice the sample cleanly even if you adjust “Sensitivity.” If the attack of the next sound is included in the end of the preceding sample, or if one sample contains two notes, you will need to edit the samples.

note If you want to edit, hold down the [ENTER] key and select the “Index” that is assigned to the note that you want to edit. (This portion of the waveform display will be highlighted.) Then you can make adjustments by adjusting “Start” or “End,” and by using Divide to separate or Link to combine. (PG p.110)

- ⑥ Press the Save button.

The Save Samples & MS dialog box will appear.

Here you can save the time-sliced samples and the multisample.

At this time, set the items in the *Save With* area to specify the conversion destination for the program that will use the samples and multisample, and for the performance data (track or pattern) that will be used in Sequencer mode to “recreate” the rhythm loop sample.

- If you want to create the performance data in a track
Turn “Program” and “Seq.Event” On (checked)
Program: I-E101
Track: On
Song: 000, Track: 01, Meter: 4/4
Start Measure: 001, Time: 008

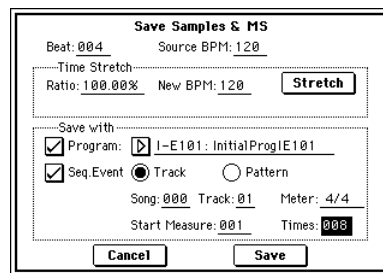

Press the Save button to save the data.

You will return to the dialog box of step ⑤.

- If you want to create the performance data in a pattern

In order to audition the performance data as it would be if created as a pattern, press the Save button once again to access the Save Samples & MS dialog box.

- Turn “Program” and “Seq.Event” On (checked)
Program: I-E102
Pattern: On
Song: 001, Pattern: U00, Meter: 4/4
RPPR: On (checked), Key: C#2, Track: 01

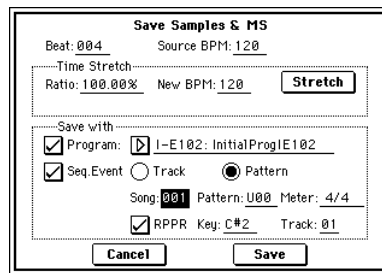

Press the Save button to save the data.

You will return to the dialog box of step ⑤.

- ⑦ Press the Exit button to return to the screen of step ②.
- ⑧ Press the [SEQ] key to enter Sequencer mode, and select 000 for “Song Select.”



The following song data has been set/created automatically as you specified in step ⑥.

- P0: Play/REC page
Song: 000, Meter: 4/4, Tempo: 120
- P0: Play/REC, Program T01-08 page
Track01 Program: INT-E101
- P5: Track Edit, Track Edit page
Track01: track data: 8 measures (D2-)

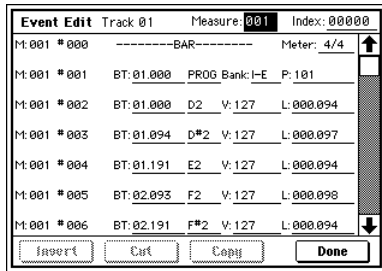

Press the SEQUENCER [START/STOP] key to start playback.

As an example, set “♩(Tempo)” to 100. Notice that the pitch does not change when you play back at a different tempo.

note If the beat of the original rhythm loop sample is not reproduced correctly when you change the tempo, or if obtrusive noise is heard, this is because the sample was not sliced appropriately in step ⑤. The way in which the percussion instrument sounds were divided will have a major impact on the quality of the playback when the tempo is changed. You will need to adjust the way in which the samples are divided in step ⑤.

note The silence between samples may become obtrusive if you play back at a slower tempo, or noise may occur between samples if you play back at a faster tempo. To avoid such problems, you can set Stretch “New BPM” or “Ratio” in step ⑥ to the tempo at which you want to play back, and execute time stretch to adjust the length of each sample. (PG p.112 ⑨)

⑨ In “Song Select,” choose 001.



The following song data has been set/created automatically as you specified in step ⑥.

- P0: Play/REC page
Song: 001, Meter: 4/4, Tempo: 120, RPPR: On
- P0: Play/REC, Program T01-08 page
Track01 Program: INT-E102
- P6: Pattern/RPPR, RPPR Setup page
Key: C#2, Assign: On,
Pattern: User, U00, Track: Track01
Pattern data: 1 measure (D2-)

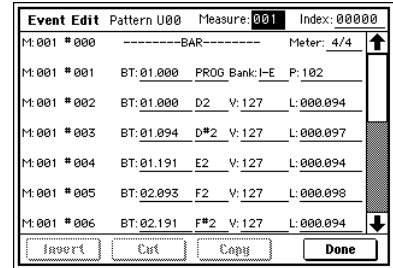
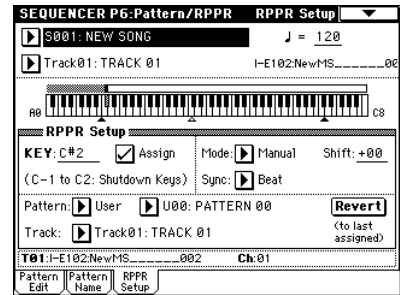

In the P6: Pattern/RPPR, Pattern Edit page, press the SEQUENCER [START/STOP] key to start playback of pattern U00.

When you press the C#2 key in the P6: Pattern/RPPR, RPPR Setup page, the RPPR function will start playing pattern U00.

In the same way as in step ⑧, changing the playback tempo will not affect the pitch.

Sampling in Program, Combination, or Sequencer modes

External audio sources can be sampled from the various input jacks in Program, Combination, and Sequencer modes as well.

A performance in the above modes can also be internally resampled in digital form. You can resample a performance that uses the TRITON STUDIO's full range of features (filters, effects, arpeggiator, and sequencer).

You can also sample the TRITON STUDIO's performance together with audio from an external input source, or monitor the performance of the TRITON STUDIO's arpeggiator and sequencer etc. while you sample only the external audio from the input jacks.

In Sequencer mode, you can sample external audio while listening to a song play back, and automatically create note data in the track that will play the sample when the track is played back. This allows you to sample vocals or guitar while the sequencer runs, just as though you were using a multitrack recorder. (This function is called "In-Track Sampling.")

For examples of sampling in Program and Combination modes, refer to p.45. The sampling procedure in Combination mode is the same as in Program mode.

Record an external audio input source while a song plays, and create event data at the same time (In-Track Sampling function)

As an example, here's how the sound of a guitar connected to the AUDIO INPUT 1 jack can be added to a song you created.

note In this example we will send the external audio input source to INDIVIDUAL 1, so if you want to monitor the sound being sampled, connect AUDIO OUTPUT (MAIN) L/MONO, R, and (INDIVIDUAL) 1 to your mixer, and use headphones etc. to monitor the output of the mixer.

- 1 In Sequencer mode, select the song to which you want to add the guitar sound.

You can either create a song, or use Disk mode to load a previously-created song.

- 2 Connect your guitar to the rear panel AUDIO INPUT 1 jack.

Set the AUDIO INPUT [MIC/LINE] switch to the LINE position, and set the [LEVEL] knob near the center position.

If you connect a passive-type guitar (without an internal preamp), the impedance mismatch will make it difficult to sample at an appropriate level. This type of guitar should be sent through a preamp or effect processor.

- 3 Access the Sequencer P0: Play/REC, Sampling page.

- 4 Set the various *Input* parameters so that the signal from the AUDIO INPUT 1 jack will be sent to INDIVIDUAL 1.

Make the following settings.

"Input": Analog

Input1 "Level": 127, "Pan": L000, "BUS Select": 1/2

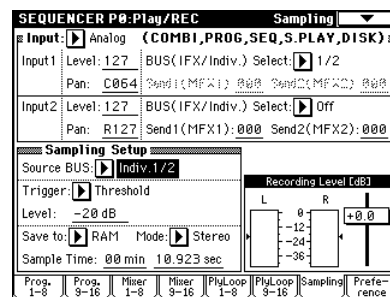

- 5 Set the recording level.

Play your guitar at the volume at which you will record.

If the display indicates "ADC OVERLOAD !!" (AD converter input overload), adjust the rear panel [LEVEL] knob toward MIN until the level is appropriate.

Press the SAMPLING [REC] key.

When you play your guitar, the level meter will indicate the volume at which the guitar will be sampled.

If the display indicates "CLIP!," use the VALUE controllers to lower the "Recording Level" slider (in the right of the display) below +0.0 to an appropriate level. This adjustment will not affect the output volume, but will affect the data that will be sampled.

When you have finished making adjustments, press the SAMPLING [REC] key.

- 6 Set the various *Sampling Setup* parameters.

Make the following settings.

"Source BUS": Indiv. 1/2

"Trigger": Threshold, "Level": as desired

"Save to": RAM, "Mode": Mono

Sample Time": as desired

- 7 Select the page menu command "Select Bank & Smpl No.," and make the following settings.

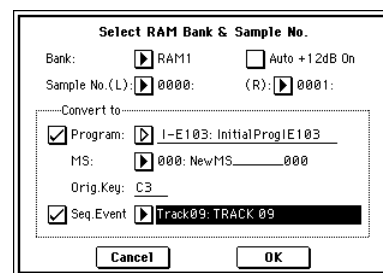

"Bank": as desired

"Program," "Seq.Event": On

"Track": a track that contains no recorded data

"Auto +12 dB On": Off (unchecked)

You should normally turn this Off when you sample external audio sources in Sequencer mode. (The power-on default is On.)

After making these settings, press the OK button to close the dialog box.

⑧ **Begin sampling.**

Press the SAMPLING [REC] key, and then the SAMPLING [START/STOP] key to enter recording-standby mode.

Press the [LOCATE] key to reset the song playback location to the beginning of the song, and press the SEQUENCER [START/STOP] key to play back.

If you want to verify the location, press the Prog.9-16 tab to access the Program T09-16 page.

Begin playing at the point where you want to record.

Sampling will begin when the Threshold “Level” volume is exceeded.

⑨ **At the point where you want to stop sampling, press the SAMPLING [START/STOP] key.**

Sampling will also stop if the specified “Sample Time” is reached.

Press the SEQUENCER [START/STOP] key to stop playback.

Event data and a program will be assigned to the track you specified in “Select Bank & Smpl No.”

⑩ **Press the [LOCATE] key to return to the beginning of the song, and press the SEQUENCER [START/STOP] key. Notice that the sampled audio is played back along with the song.**

.....

Resampling the song playback to create a WAVE file on the hard drive

Here’s how you can play back a song you created, and sample it to the hard drive. When you sample to the hard disk, a WAVE file will be created.

note If you want to sample to an external SCSI hard disk, make connections as described on PG p.298.

① **In Sequencer mode, select the song from which you want to create a WAVE file.**

Either create a song, or use Disk mode to load a previously-created song.

⚠ A maximum of 80 minutes for either mono or stereo can be written to hard disk in one sampling operation (monaural: approximately 440 Mbytes, stereo: approximately 880 Mbytes).

② **Access the Sequencer P0: Play/REC, Sampling page.**

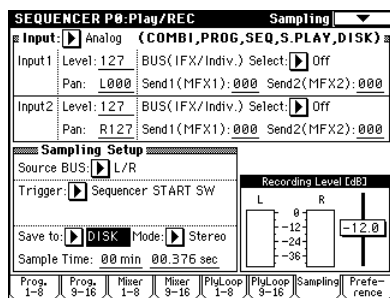

Specify the sampling method.

“Source BUS”: L/R

“Trigger”: Sequencer START SW

“Save to”: DISK, “Mode”: Stereo

③ **Select the page menu command “Select Directory,” and specify the destination to which the WAVE file will be written.**

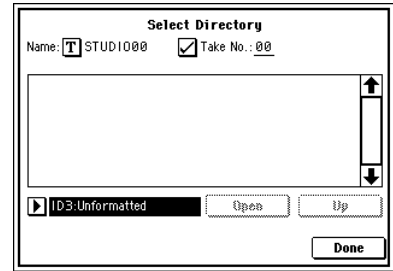

Use drive select and the Open and Up buttons to select the directory in which the WAVE file will be saved.

If you want to create a new directory, access the Disk mode Utility page, and execute the page menu command “Create Directory.”

Press the text edit button to access the text edit dialog box, and input a filename (up to six characters).

Leave “Take No.” checked. The number at the right of “Take No.” will be input as the last two characters of the filename.

This number will increment each time you sample, ensuring that the filename will not be the same even if you sample repeatedly.

After you have made the settings, press the **Done** button to close the dialog box.

④ **Set “Sample Time” to the length that you want to sample.**

Set this to a length slightly greater than the length of the song.

⑤ **Set the recording level.**

Press the SAMPLING [REC] key.

⚠ It will take between several seconds to nearly a minute from the moment you press the SAMPLING [REC] key until the TRITON STUDIO enters standby mode (i.e., until the SAMPLING [REC] key LED changes from blinking to lit). This time is required in order to allocate sufficient space on the hard disk.

Press the SEQUENCER [START/STOP] key to play back the song, and adjust the resampling volume while you watch the level meters.

Set “Recording Level” to **-12.0** (dB). If the level meter indication is too low, use the VALUE controller to raise the level from -12.0 as far as possible without causing the “CLIP!!” indicator to appear. The output volume will not change at this time, but your adjustment will affect the data that will be sampled. (p.105)

note The power-on default setting is -12 dB. At the -12 dB setting, CLIP will not appear even if the song is played back at the maximum level.

When you finish making adjustments, press the SAMPLING [REC] key.

Press the SEQUENCER [START/STOP] key to stop the song playback. Then press the [LOCATE] key.

⑥ **Start sampling.**

Press the SAMPLING [REC] key and then the SAMPLING [START/STOP] key to enter recording-standby mode.

Press the SEQUENCER [START/STOP] key to play back the song. Sampling will begin at the same time.

⑦ **When the song finishes playing back, press the SAMPLING [START/STOP] key to stop sampling.**

Use the page menu command “Select Directory” to verify that the WAVE file was created. Select the file and press the SAMPLING [START/STOP] key to listen to the sound that was sampled.

note The pickup level of a WAVE file is specified by the “WAVE File Play Level” (PG p.138).

Creating an audio CD from WAVE files sampled to hard disk

This section explains how you can create an audio CD by specifying the desired order of WAVE files on the hard disk.

As described in “Resampling the song playback to create a WAVE file on the hard drive” (PG p.116), a song you created in Sequencer mode can be sampled to the hard disk to create a WAVE file.

➤ To do this, the CDRW-1 option (PG p.286) must be installed or an external CD-R/RW drive must be connected to the SCSI connector (PG p.298).

➤ In order to write data to CD-R/RW media, the drive containing the WAVE files must have at least as much free space as the WAVE files. Before you execute this procedure, make sure that the drive containing the WAVE files has sufficient free space.

① Access the Disk mode Make Audio CD page.

In the default state, the WAVE File area will show only “====End====.”

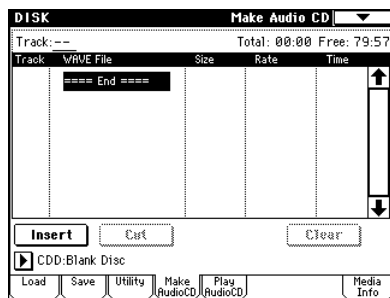

② To the track list, add the WAVE files that you want to write to the CD.

Select “====End====” (it will be highlighted), and press the **Insert** button.

The Insert Track dialog box will appear.

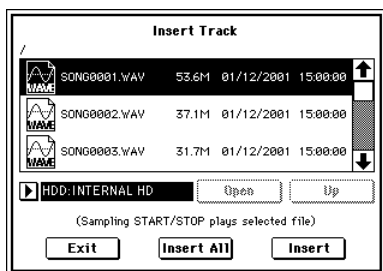

Use drive select and the **Open** and **Up** buttons to access the directory that contains the WAVE file, and select the WAVE file that you want to add to the list.

If you want to audition the file, you can press the SAMPLING [START/STOP] key to play back the sample.

➤ If you have selected a WAVE file of a sampling frequency other than 44.1 kHz or 48 kHz, it will not be possible to press the Insert button.

➤ WAVE files at a sampling frequency of 48 kHz will be converted to 44.1 kHz when they are written to an audio CD (when you execute “Write to CD”).

To add the file, press the Insert button.

You can continue adding files until you press the Exit button. The files will be added to the track list in the order in which you selected them. If you want to add all the WAVE files in the directory, press the Insert All button.

When you have finished adding files to the list, press the Exit button to close the dialog box.

Notice that the WAVE files have been added to the track list.

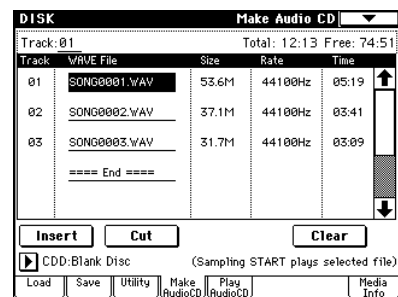

In this page as well, you can select a WAVE file and press the SAMPLING [START/STOP] key to play back the sample.

To add other WAVE files to the track list, press the Insert button once again.

If you want to add another track, select the WAVE file that follows the track you want to add. If you want to add the track to the end of the track list, select “====End====.” Then press the Insert button.

To delete a WAVE file from the track list, select the WAVE file that you want to delete, and press the Cut button.

Subsequent tracks will be moved forward in the list.

note For details on editing operations such as Clear and Swap Track, refer to PG p.173.

③ Insert a blank CD-R or CD-RW disk into the drive.

Use the Make Audio CD page drive select area to select your CD-R/RW drive.

If you are using the CDRW-1 option, the drive select area will indicate “CDD: Blank Disc.”

If you are using a SCSI-connected CD-R/RW drive, the display will indicate “ID*:Blank Disc.” (* will be the SCSI ID number.)

➤ An audio CD cannot be created on a disc that contains data other than audio (e.g., files). In this case, it will not be possible to select the page menu commands “Write to CD” or “Finalize Audio CD.”

note Even when the recommended CD-R/RW media is used, some audio CD players may be unable to play back the disc. Also, since some audio CD players are unable to play back CD-RW media, we recommend that you use CD-R media.

- ④ Select the page menu command “Write to CD” to access the dialog box, and specify how the CD will be written.

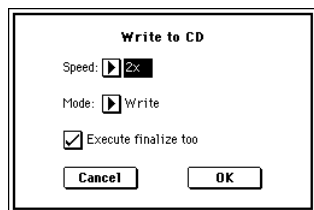

Use “Speed” to set the writing speed. This will indicate the speeds supported by the CD-R/RW drive you are using.

In this example, set “Speed” to 2x.

- ⚠ Be aware that if you use a faster writing speed in a slower system, writing errors will occur.

Use “Mode” to specify the writing method.

note Depending on the drive you are using, it may not be possible to write at the specified speed. We recommend that the first time you write, you select **Test** to perform a writing test in order to determine the speed capabilities of your drive. **Test** will not write data to the CD-R/RW media, but will perform all other processing just as when data is actually written. If an error occurs, the display will indicate “Error in writing to medium.”

Press the **OK** button to execute the writing test.

After verifying that data can be written correctly at the specified speed, select **Write**.

“Execute finalize too” specifies whether Finalization will be executed after the audio tracks have been written to the CD-R/RW media. If finalization has been executed, the disc can be played back on a CD player, but it will no longer be possible to add more tracks.

note If you only want to execute finalization, execute “Finalize Audio CD.”

- ⑤ When you are ready to write to the CD-R/RW media, or to execute a writing test, press the **OK** button. To cancel without executing, press the **Cancel** button.

- ⚠ When you press the **OK** button, the “Obey Copyright Rules” dialog box will appear.

Carefully read “About copyright” (p.iii). If you accept the terms, press the **OK** button to write to the CD or to perform the test. If you do not accept the terms, press the **Cancel** button to cancel the operation.



- ⚠ In order to avoid causing errors, do not subject the drive to physical shock or vibration while CD-R/RW media is being written.

- ⑥ An audio CD to which audio tracks have been written and which has been finalized can be played in the Play Audio CD page, allowing you to hear the CD you created.

Press the Play Audio CD tab to access the Play Audio CD page.

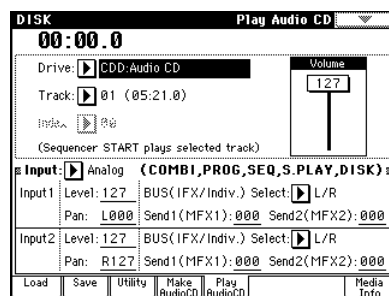

In “Drive,” select your CD-R/RW drive. “Drive” will indicate **Audio CD** (p.156).

Make the following settings to allow monitoring.

“Input”: Analog

Input1 “BUS(IFX/Indiv.)” L/R, “Level” 127, “Pan” L000

Input2 “BUS(IFX/Indiv.)” L/R, “Level” 127, “Pan” R127

“Volume” 127

Use “Track” to select the track, and press the SEQUENCER [START/STOP] key to begin playback.

Saving a track list that you have completed or partially edited

- ⚠ The track list will be lost when the power is turned off. If you want to keep this data, you must save it.

- ① In the **Save** page, select the directory in which you want to save the track list.
- ② Select the page menu command “Save Audio CD Track List” to access the dialog box.
- ③ Press the **OK** button to save the data, or press the **Cancel** button to cancel without saving.

SMF (Standard MIDI File) playback

In Song Play mode, you can play back Standard MIDI Files (SMF) directly from media such as floppy disk or hard disk. You can select this mode if you simply want to play back the SMF without editing it.

- 🔍 If the EXB-MOSS is installed, the special bank INT-F can be used in Song Play mode as well. For details on the bank INT-F parameters, refer to the EXB-MOSS owner's manual.
- 🔍 The parameter settings of Song Play mode are not backed up when the power is turned off. If you wish to save the program, track parameter, and effect settings of the song, use the page menu command "Save Template Song" to save them.
- 🔍 While playing back data from a disc inserted in the CDRW-1 option, do not subject the TRITON STUDIO to physical shock or vibration. If you play the keyboard or controllers, the data may not play back correctly.

The structure of Song Play mode

As shown in the diagram below, Song Play mode consists of tracks 1-16, effects and arpeggiator.

About SMF

SMF data in format 0 or format 1 can be played back in Song Play mode. The TRITON STUDIO recognizes only files with an extension of .MID as SMF data. Be sure that the filename extension is .MID.

About MIDI

Track status settings in Song Play mode

You can select whether the musical data played by a track, or the data produced by operating the TRITON STUDIO's keyboard and controllers will sound the TRITON STUDIO's internal tone generator, and/or will sound an external tone generator.

When the "Status" of a track is set to INT, the data played back by that track and the data produced by operating the keyboard or controllers of the TRITON STUDIO will play and control the TRITON STUDIO's internal tone generator. When the "Status" of a track is set to EXT or BTH, the data played back by that track and the data produced by operating the keyboard or controllers of the TRITON STUDIO will play and control an external tone generator. (The MIDI channel of the external tone generator must match the "MIDI channel" of the TRITON STUDIO track that is set to EXT or BTH.) With a setting of BTH, the external tone generator and the TRITON STUDIO's own tone generator will be played and controlled simultaneously. (PG p.126)

E	To	T1	T2	T3	T4	T5	T6
Keyboard/Drums	Keyboard/Keyboard	Keyboard/Keyboard	Keyboard/Keyboard	Keyboard/Keyboard	Keyboard/Keyboard	Keyboard/Keyboard	Keyboard/Keyboard
INT	INT	EXT	INT	INT	INT	INT	INT
Use Program's Scale							

Synchronization with external devices

In Song Play mode, the TRITON STUDIO will be the master (the controlling device) regardless of the MIDI Clock setting (Global P1: MIDI "MIDI Clock") (PG p.266).

Insert effects, Master effects

The TRITON STUDIO's effects can be used in the same way as in Sequencer mode. (PG p.141, PG p.131)

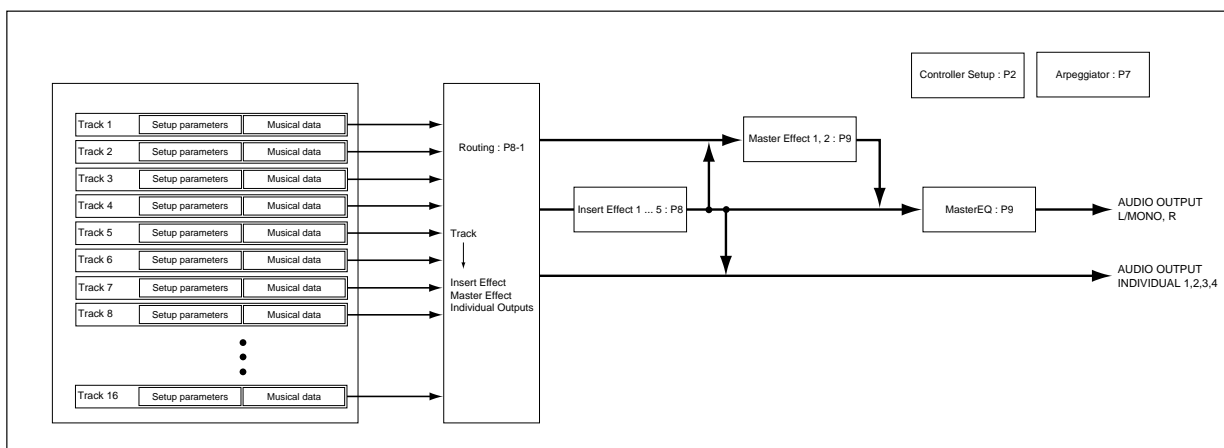

Playing SMF data

Direct playback from external media such as a floppy disk

 When you wish to playback SMF data that is compatible with the GM/GS/XG standards, set “Bank Map” (Global P0: Basic Setup, System Preference page) to GM(2).

- ① Press the [S.PLAY] key to enter Song Play mode.
- ② Press the [EXIT] key to display the P0: Prog/Mix page.
- ③ Make sure that the media containing the SMF data can be detected.

If you want to play back data from a floppy disk, insert the floppy disk into the TRITON STUDIO's disk drive. If you want to play back data from an external SCSI device, make sure that the external SCSI device is connected. Also make sure that the media contains SMF data.

If there is no SMF data in the floppy disk, or if there is no SMF data in the currently selected directory, no filename will be displayed (as shown below).



To move to a directory that contains SMF data, press the [MENU] key, and then press “P3: Select Directory” to display P3: Select Directory.

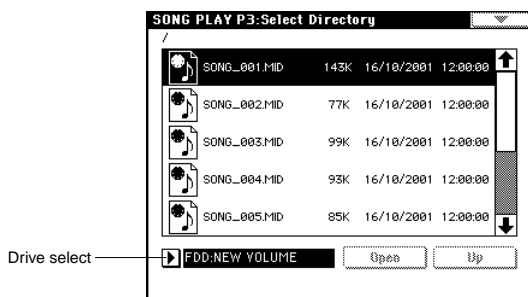

Press the drive select button, and select the drive that contains the data that you want to play. Then press the **Open** button or **Up** button to move between levels, and find the desired SMF. When the SMF file (make sure that the extension is .SMF) appears in the LCD screen, press the [EXIT] key, and move to P0: Prog/Mix. “File Select” will show the SMF filenames.

note If no jukebox list has been created, no filenames will be displayed if the “Jukebox” check box is checked. Uncheck the “Jukebox” check box.

- ④ Press the “File Select” popup button. From the file list, choose the filename that you wish to play back.



- ⑤ Press the SEQUENCER [START/STOP] key. Playback will begin. At this time, all songs displayed in the “File Select” popup button will playback consecutively (if “Auto Start” is checked).
- ⑥ Press the SEQUENCER [START/STOP] key once again to stop playback.

Starting/stopping playback for each song

In the P0: Prog/Mix, Preference page, uncheck “Chain to next file” or “Auto Start,” and press the SEQUENCER [START/STOP] key. Playback will begin, and will stop when each song ends. For details on these settings (PG p.125).

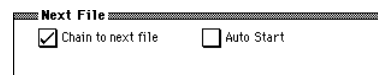

Mute/Solo function

In P0: Prog/Mix, the Program T01-08 and T09-16 pages provide **PLAY/MUTE** buttons and **SOLO ON/OFF** buttons that allow you to play and mute tracks 1-16 in the same way as in Sequencer mode. You can use these when you wish to mute the melody track and play the part yourself on the keyboard (“minus-one play”), or when you wish to audition a track (PG p.82). You can use the “Solo Selected Track” page menu command to audition only the currently selected track. This provides a convenient way to hear the parameter settings and effect settings of a track (PG p.52, 124).

Playback using the Jukebox function

The TRITON STUDIO provides a Jukebox function that can be used to playback SMF data. This function allows you to specify the order in which files in the same directory will be played.

⚠ Any jukebox list you create will be erased when the power is turned off, and cannot be recovered. If you wish to keep your jukebox list, refer to the section “Saving a Jukebox list” (next page), and save it onto media.

- 1 Press the [EXIT] key to display the P0: Prog/Mix page.
- 2 Check the “Jukebox” check box.

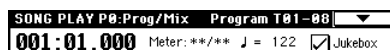

- 3 Select P3: Jukebox.

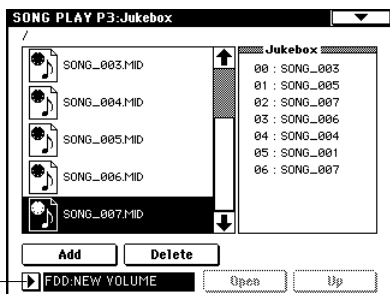

Press the drive select button, and select the drive that contains the data that you want to play back.

- 4 Use the scroll bar to display the SMF (filename extension .MID) that will be played first, and select that file.
- 5 Press the Add button.

The filename you specified in step 4 will appear in the Jukebox list.
- 6 Select the file that will be played second, and press the Add button.

Add files to the Jukebox list in the order that they will be played. A maximum of 100 files (00–99) can be registered in the Jukebox list.

To delete a file from the Jukebox list, press the Delete button.
- 7 Press the [EXIT] key to display P0: Prog/Mix.
- 8 Press the SEQUENCER [START/STOP] key.

The files will playback in the order in which they were registered.
- 9 Press the SEQUENCER [START/STOP] key once again to stop playback.

⚠ Only files in the same directory can be registered in a jukebox list.

If you perform the following operations while creating a jukebox list, the jukebox list will be lost.

- Change the directory
- Remove media (such as the floppy disk)
- Change drives

Saving a Jukebox list

Saving procedure

- 1 Use the procedure described above to create a jukebox list.
- 2 If you want to save the jukebox list on the internal hard disk or an external SCSI device, use the P3: Jukebox drive select button to select the drive on which you want to save the data.
- 3 In P3: Jukebox, select the “Save Jukebox List” page menu command.

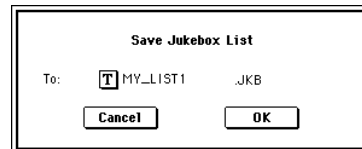

- 4 Use the text edit button to enter a name for the jukebox list (see p.40, 57).
- 5 Press the OK button.

The jukebox list will be saved to the media.

Loading procedure

- 1 In the Jukebox page, select a jukebox list (filename extension JKB).
- 2 Press the “Load Jukebox List” page menu command.

The jukebox list will be loaded into the TRITON STUDIO.

Playing along with SMF data

- ⚠ Do not subject the TRITON STUDIO to physical shock or vibration while playing back data from a disc in the CDRW-1 drive (if installed). If you perform on the keyboard or controllers at this time, the data may not play back correctly.

Minus-one play

You can enjoy “minus-one” play by playing back SMF data, muting a specific part, and playing that part yourself.

- ① **Playback the SMF data, identify the track whose part you wish to play, and stop playback** (see p.121).
- ② **In P0: Prog/Mix, select the Prog. 1-8 tab or Prog. 9-16 tab.**
- ③ **Use “Play Track Select” to select the track for the part that you want to play from the keyboard.**

When you play the keyboard, the program of the selected track will be heard.



- ④ **Press the “PLAY/MUTE” button to set the track selected in step ③ to MUTE.**
If you want the musical data of the track to playback in addition to your own playing on the keyboard, set “Play/Mute” to **PLAY**.
- ⑤ **Press the SEQUENCER [START/STOP] key to begin playback, and play along on the keyboard with the song.**

Arpeggiator

You can use the arpeggiator for your keyboard performance (see p.132, PG p.129).

Settings for the entire TRITON STUDIO (Global settings)

In Global mode you can make settings that affect the entire TRITON STUDIO, such as master tune, key transpose, effect global switch, global MIDI channel, and system clock. In this mode you can also make settings for the damper pedal, assignable foot switch/pedal, and edit the program/combination category names. You can also create user drum kits (see p.128) and user arpeggio patterns (see p.134).

⚡ The edits you perform in Global mode will be preserved until the power is turned off, but will not be preserved after the power is turned off. Three types of data are handled in Global mode: user drum kit settings (Global P5), user arpeggio pattern settings (Global P6), and all other global settings (Global P0–P4). Each of these can be written into their respective memory area. This data can also be saved to various types of media in Disk mode. (see p.58, 59)

⚡ Global mode does not provide a “Compare” function that lets you return to the state of the data before it was edited.

Tuning to another instrument/ Transposing

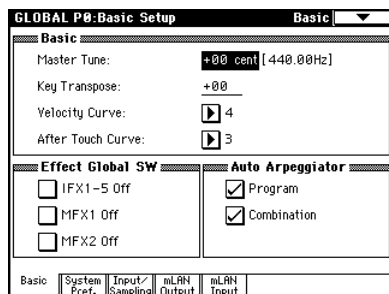

When you play the TRITON STUDIO together with other instruments, or along with music on a CD or tape, you may need to adjust the tuning so that the pitch matches. To adjust the tuning, use Global P0: Basic Setup, Basic page “Master Tune.” The tuning can be adjusted in a range of **-50 – +50 cents** (one semitone is 100 cents).

You can also transpose by changing the pitch in semitone steps. To transpose the pitch of the entire TRITON STUDIO, use Global P0: Basic Setup, Basic page “Key Transpose.” The pitch can be transposed over a range of **±1 octave**.

Here we will explain how to adjust the tuning and transposition of the entire TRITON STUDIO.

- 1 Press the [GLOBAL] key to enter Global mode.
- 2 Press the [EXIT] key.
- 3 Select the Basic tab.
- 4 To adjust the tuning, select “Master Tune.” to adjust the transposition, select “Key Transpose.”
- 5 Use the VALUE controllers to adjust the setting.

You can use numeric keys [0]–[9] to enter a value and press the [ENTER] key. Alternatively, you can use the [VALUE] dial, the [VALUE] slider, or the [△][▽] keys.

Adjusting the way in which velocity or after touch will affect the volume or tone

You can adjust the way in which changes in velocity or after touch will affect the volume or tone. By changing this, you can (for example) make the volume of the notes more consistent even when they are played with varying velocities (dynamics). Each curve has its own character, so you can select the curve that is appropriate for your own playing dynamics, playing style, and the effect that you wish to obtain (see PG p.135).

- 1 Press the [GLOBAL] key to enter Global mode.
- 2 Press the [EXIT] key.
- 3 Select the Basic tab.
- 4 To change the velocity curve, select “Velocity Curve” and specify the desired curve.

To change the after touch curve, select “After Touch Curve,” and specify the desired curve.

note This setting will affect the operation of the entire TRITON STUDIO.

note Each program has parameters that allow you to adjust the effect of velocity (playing dynamics), and the change will depend on the settings of these parameters. These parameters can be individually set in detail in Program mode.

Bypassing the effects

Normally, effects are turned on/off within each program, combination, or song, or in Sampling mode or Song Play mode. However if you want the entire TRITON STUDIO not to use its insert effects or master effects, you can bypass these effects.

This is set by the *Effect Global SW* parameter in the Global P0: Basic Setup, Basic page.

- 1 Press the [GLOBAL] key to enter Global mode.
- 2 Press the [EXIT] key.
- 3 Select the Basic tab.
- 4 To turn off insert effects 1–5, check the “IFX1–5 Off” check box.

To turn off master effect 1, check the “MFX1 Off” check box. To turn off master effect 2, check the “MFX2 Off” check box.

Recalling the last-selected mode and page at power-on

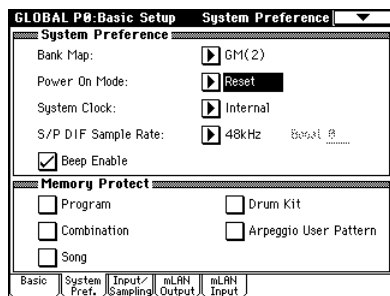

The state of TRITON STUDIO when the power is turned on will depend on the setting of “Power On Mode” (Global P0: System Preference page).

If “Power On Mode” is **Reset** (factory setting), TRITON STUDIO will automatically select the Combination mode P0: Play.

If “Power On Mode” is **Memorize**, TRITON STUDIO will be in the mode and page that were last selected when the power was turned off.

The **Memorize** setting will remember the mode and page that were last selected, the combination number that was last selected in Combination mode, and the program number that was last selected in Program mode. If another mode is selected when the power is turned on, you can press the [COMBI] key or [PROG] key to select the P0: Play page with the last-selected combination number or program number.

Specifying the function of the ASSIGNABLE Switch and ASSIGNABLE Pedal

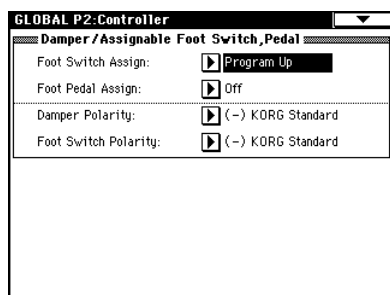

Sets the function of an assignable switch such as the optional Korg PS-1 connected to the **ASSIGNABLE SWITCH** jack.

This switch can act as a source for alternate modulation or effect dynamic modulation, or switch portamento on/off, control the sostenuto effect, turn the soft pedal effect on/off, turn the arpeggiator on/off, select programs or combinations (up/down), start/stop the sequencer, punch-in/out on the sequencer, or be a trigger to advance the cue list step (PG p.251).

- This setting is made in Global P2: Controller “**Foot Switch Assign.**”

You can specify the function that will be performed by an assignable pedal (the optional XVP-10 or EXP-2) connected to the **ASSIGNABLE PEDAL** jack.

This pedal can be used to control master volume, alternate modulation or effect dynamic modulation, portamento pitch change speed, volume, the pan following an insert effect, pan, volume, or send levels to the master effects (PG p.252).

- This setting is made in Global P2: Controller “**Foot Pedal Assign.**”

note You can use this as a source for alternate modulation or effect dynamic modulation, and use it to control program parameters or effect parameters. In this case, set “**Foot Switch Assign**” to **Foot SW (CC#82)**, and “**Foot Pedal Assign**” to **Foot Pedal (CC#04)**.

Here we will show how to make settings that allow an assignable switch to change programs or combinations.

- ① **Connect an optional Korg PS-1 to the ASSIGNABLE SWITCH jack.**
- ② **Press the [GLOBAL] key to enter Global mode.**
- ③ **After pressing the [MENU] key, and press the P2: Controller.**
- ④ **Press the “Foot Switch Assign” popup button, and press either Program Up or Program Down.**

Program Up will cause the next higher program number to be selected each time you press the foot switch. **Program Down** will cause the next lower program number to be selected each time you press the foot switch.

- ⑤ **Set the “Foot Switch Polarity” to the polarity of the foot switch you have connected.**

If you have connected a Korg PS-1 pedal switch, set this to **(-) KORG Standard**. If the polarity is not set correctly, the pedal will not function appropriately.

- ⑥ **Either press the [PROG] key to enter Program P0: Play, or press the [COMBI] key to enter Combination P0: Play. When you press the foot switch, the program/combination will change.**

.....

Creating original scales

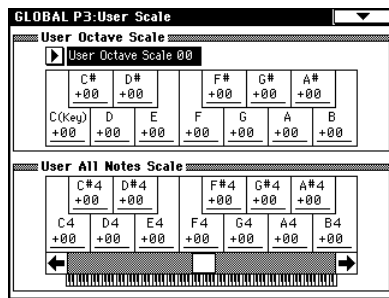

You can create your own original scales. You can create sixteen different **User Octave Scales** in which the pitch of each note of the octave is repeated for all octaves, and one **User All Note Scale** in which the pitch of each of the 128 notes can be specified independently.

By adjusting the pitch of each key in the range of ± 99 , you can raise or lower it by as much as approximately one semitone relative to the normal pitch.

The user scales you create here can be used by specifying the scale for a program, for each timbre of a combination, or for each track of a song (Sequencer/Song Play).

Changing the scale

You can specify the scale for each program, for each timbre in a combination, or for each track of a song.

These settings are made by the *Scale* "Use Prog's Scale" parameters in the following pages.

Program mode	Program P1: Edit-Basic, Program Basic
Combination mode	Combination P2: Edit-Trk Param, Other
Sequencer mode	Sequencer P2: Trk Param, Other
Song Play mode	Song Play P1: Track, Status/Scale

Here we will show how to make settings in Sequencer mode.

- ① Press the [SEQ] key to enter Sequencer mode.
- ② After pressing the [MENU] key, and press the P2: Trk Param.
- ③ Press the Other 1-8 tab or Other 9-16 tab to select the Sequencer P2: Trk Param, Other page.
- ④ If you wish to use the scale that is specified for the program used by a track, check the "Use Program's Scale" check box for that track.
Tracks that are not checked will use the scale specified by Scale "Type (Song's Scale)."
- ⑤ Set "Type (Song's Scale)" to select the scale for the entire currently selected song.

Drum kit settings

This section explains how to edit a drum kit.

- 🔊 When you play the keyboard in Global mode, the TRITON STUDIO will sound as in the previous mode in which you were previously. Be aware that if you moved from Sampling mode to Global mode in a state where the sample memory (RAM) contained no data (such as immediately after the power is turned on), playing the keyboard will not produce sound.
- 🔊 When you move from Sequencer to Global mode, playing the keyboard will sound the program or arpeggiator that corresponds to the global MIDI channel (set in Global P1).
- 🔊 The settings that you edit in Global mode are preserved as long as the power remains on, but will be lost if not written to memory before the power is turned off. The data handled in Global mode can be classified into three types: user drum kit settings (Global P5), user arpeggio pattern settings (Global P6), and all other global settings (Global P0–P4). Each of these three types of data can be written into the memory area. This data can also be saved to various types of media in Disk mode. (☞p.58, 59)
- 🔊 Global mode does not provide a Compare function that lets you make before-and-after comparisons of your editing. Before editing user drum kits, or user arpeggio patterns, you may wish to use “Copy Drum Kit” or “Copy Arpeggio Pattern” to copy the user drum kit or user arpeggio pattern to an unused number.

About drum kits

A drum kit consists of drum samples (PCM drum waveform data) assigned to individual notes, with individual adjustments for pitch and level, etc.

The TRITON STUDIO has 144 drum kit memory areas. When shipped from the factory, some of the 000 (I-A/B)–015 (A/B) and 128 (User)–143 (User) areas contain pre-loaded drum kits suitable for various musical styles.

In Global P5: Drum Kit you can edit these drum kits to create your own original drum kits. You can also create original drum kits using sample waveforms that you sampled on the TRITON STUDIO or loaded into sample memory (RAM) in Disk mode.

A drum kit that you edited or created can be written into one of the user drum kit memory areas 000 (I-A/B)–143 (User). Drum kits can also be saved to various types of media in Disk mode.

144 (GM)–152 (GM) contain nine different preset drum kits that are compatible with the GM2 sound map. (☞For details on the factory-set drum kits, refer to “VNL”.)

Multisample programs and drum kit programs

There are two types of programs: those whose oscillator uses a **multisample**, and those whose oscillator uses a **drum kit**.

This selection is made by the Program P1: Edit-Basic, Program Basic page “Oscillator Mode” setting. To use a multisample for the program, set “Oscillator Mode” to **Single** or **Double**. To use a drum kit, set “Oscillator Mode” to **Drums**.

About program parameters

Just as the character and effect processing of a melodic instrument such as piano, organ, trumpet, or strings is fundamentally different from that of percussion instruments such as drums or timpani, the program parameter structure of a multisample program (“Oscillator Mode” = **Single** or **Double**) is fundamentally different from that of a drum kit program (“Oscillator Mode” = **Drums**). The program parameters of a multisample specify filter and amp settings etc. appropriate for a multisample. For this reason, it is difficult to convert such a program for use with a drum kit. Thus if you wish to edit a drum kit, you should first use Program mode to select a program that uses a drum kit (“Oscillator Mode” = **Drums**), and then move to the Global P5: Drum Kit page.

Editing a drum kit

⚠ Before editing a drum kit, uncheck the Memory Protect (☞p.57).

① In Program P0: Play, select the program that you wish to use while editing the drum kit.

Select a drum kit program from the preload programs etc. If the drum kit that you will be editing is already being used by a program, select that program. (In the separate "VNL," programs that use a drum kit are marked by a Ⓞ symbol.)

⚠ Set "Octave" (Program P1: Edit-Basic, OSC Basic page) to +0 [8']. With a setting other than +0 [8'], the relationship between the keys and the sounds will be incorrect.

⚠ The effects will sound using the settings of the last-selected program.

⚠ When you edit a drum kit, all programs that use that drum kit will be affected.

② Access the Sample Setup page of Global P5: Drum Kit.

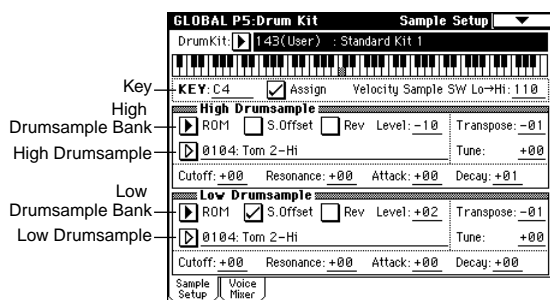

③ In "Drum Kit," select the drum kit that you wish to edit.

If necessary, use the page menu command "Copy Drum Kit" to copy settings from a preload drum kit or a GM drum kit.

⚠ GM drum kits 144 (GM) – 152 (GM) cannot be selected here. (It is not possible to edit or write a GM drum kit.) If you wish to modify the settings of one of the drum kits 144 (GM) – 152 (GM), you can use "Copy Drum Kit" to copy it to 000 (I-A/B) – 143 (User), and then edit the copy.

④ Use "Key" to select the note number that you wish to edit.

The drum sample parameters for the selected note number will be displayed in the *High Drumsample*, *Low Drumsample*, and *Voice/Mixer* pages.

To select a note number, you can use the VALUE controllers, or you can hold down the [ENTER] key and press a note on the keyboard.

⑤ Use the "Assign" check box to specify whether a drum sample will be assigned to the note number.

If this is checked, a drum sample will be assigned to that note number. Normally you will check this.

If this is not checked, no drum sample will be assigned to that note number. That note number will sound the drum sample assigned at its right, but a semitone lower. Use this setting when you want only to change the pitch, such as with tom or cymbal sounds.

note If you uncheck the "Assign" check box so that the drum sample at the right will be played at a pitch one semitone lower, access the Program P2: Edit-Pitch, OSC1 Pitch Mod. page, and set "Pitch Slope" to +1.0 before you enter Global mode.

⑥ Use "High Drumsample Bank," "High Drumsample," "Low Drumsample Bank," and "Low Drumsample" to specify the drum sample that will be assigned to this note number.

If you have selected a Low Drumsample, use "Velocity Sample SW Lo→Hi" to specify how velocity will switch between the High Drumsample and Low Drumsample. (☞⑦)

ROM drumsamples can be selected if "High/Low Drumsample Bank" is set to ROM, samples you recorded on the TRITON STUDIO or loaded in Disk mode can be selected if you set this to RAM, and drum samples from a EXB-PCM option (if installed) can be selected if you set this to EXB.

⚠ Some of the EXB-PCM series options do not contain drum samples.

About the ROM drum samples

The TRITON STUDIO contains 417 different drum samples in ROM. When you press the popup button, you will be able to select ROM drum samples from 15 categories. (☞For a list of the drum sample names, refer to "VNL")

⑦ Use "Velocity Sample SW Lo→Hi" to specify how velocity will switch between drumsamples.

The drumsample that sounds when you perform will depend on the velocity (keyboard playing strength) of the incoming note. This is called velocity drumsample switching.

If you set this to 001, only the High Drumsample will sound.

☞ This is the same type of function as the Velocity Multi-sample Switching in a program. ("High Multisample and Low Multisample" ☞p.69)

⑧ Set the parameters of the drumsamples that you assigned.

Set the parameters for the High Drumsample and Low Drumsample.

You can set parameters such as volume level ("Level"), pitch ("Transpose," "Tune"), and tone ("Cutoff," "Resonance"). (☞For details on each parameter, refer to PG p.148.)

⑨ As necessary, repeat steps ④–⑧ to set drumsample parameters for each note number.

If you wish to use the settings of another "KEY," select the page menu command "Copy Key Setup".

⑩ Select the Voice/Mixer page in Global P5: Drum Kit.

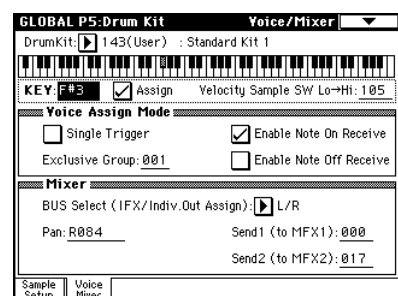

⑪ **Set the “Exclusive Group.”**

The “Exclusive Group” setting is used when you wish to group drumsamples of the same type. For example if the note number assigned to an open hi-hat drumsample and a closed hi-hat drumsample are set to the same exclusive group number, the open hi-hat and closed hi-hat can not be sounded simultaneously, ensuring that the hi-hat performance will sound natural.

⑫ **Use “BUS Select” to specify the output routing.**

Set this when you wish to send the output of the drum-sample assigned to each note number to its own insert effect or AUDIO OUTPUT (INDIVIDUAL) jack 1–4. For example you might send all snare sounds to **IFX1**, all kick sounds to **IFX2**, and the remaining sounds to **L/R**. You can also specify **1, 2, 3, 4, 1/2, or 3/4** so that specific drum samples will be sent to the AUDIO OUTPUT (INDIVIDUAL) 1–4 jacks.

The settings you make here are used if “Use DKit Setting” (Program P8: Edit-Inert Effect, Routing page) is **checked** for the program that uses this drum kit. (PG p.28, 179)

⑬ **Use “Pan” to specify the stereo output position.**

The setting you make here is valid if the “Use DKit Setting” is **checked** (Program P4: Edit-Amp., Amp1 Level/Pan page) for the program that uses this drum kit (PG p.21).

⑭ **Use “Send1(MFX1)” and “Send2(MFX2)” to set the send levels to the master effects.**

The settings you make here are valid if the “Use DKit Setting” is **checked** (Program P8: Edit-Inert Effect, Routing page) for the program that uses this drum kit (PG p.28).

⑮ **Use the page menu command “Write Drum Kits” to save the data.**

If you wish to change the name of the drum kit before you save it, use the page menu command “Rename Drum Kit” (p.57).

 If you turn off the power before writing the data into memory, your edits will be lost (“Memory in Global mode” p.59).

Arpeggiator settings

This chapter describes the procedure for making arpeggiator settings in each mode. For details on the arpeggiator function, refer to “Using the arpeggiator while you play” (p.29).

Arpeggiator settings for a program

Arpeggiator on/off

Each time you press the ARPEGGIATOR [ON/OFF] key, the arpeggiator will be switched on or off. When on, the ARPEGGIATOR [ON/OFF] key LED will light. When you play the keyboard, an arpeggio will play according to the selected arpeggio pattern.

note The on/off setting is stored when the program is written.

Arpeggiator settings

- 1 Select the Program P7: Edit-Arpeggiator, Arpeg. Setup page.

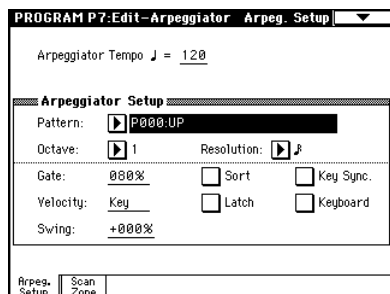

- 2 Use “J (Tempo)” to set the tempo.

You can adjust the tempo by rotating ARPEGGIATOR [TEMPO] knob. The LED will blink at the specified tempo.

MIDI If “MIDI Clock” (Global P1: MIDI) is set to **External MIDI** or **External mLAN**, the display will indicate “J = EXT.” This setting lets you synchronize the tempo with an external MIDI device. In this case, it will not be possible to change the tempo on the TRITON STUDIO.

- 3 In “Pattern,” select the arpeggio pattern.

You can select from preset arpeggio patterns **P000–P004** and user arpeggio patterns **U000 (I-A/B)–U506 (User)**.

The way in which the pattern is played will depend on settings such as “Octave” and “Sort.” **P000–P004** in the following diagrams show how the arpeggio will be played when “Octave” is set to **1**, and “Sort” is checked. **P004: RANDOM** is only one possibility.

P000: UP

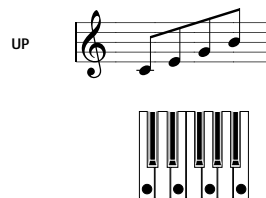

P001: DOWN

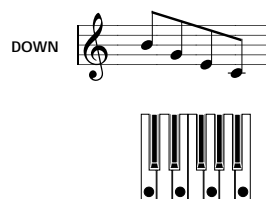

P002: ALT1

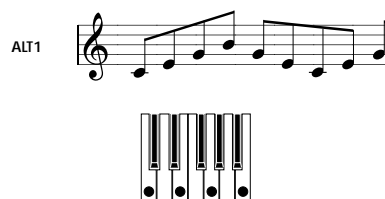

P003: ALT2

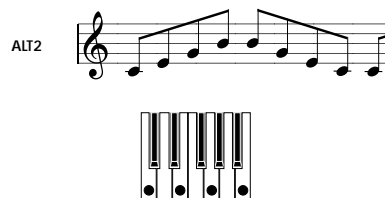

P004: RANDOM

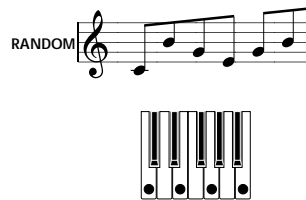

U000 (I-A/B)–U199 (I-A/B)

With the factory settings, various arpeggio patterns are preloaded. These include a variety of patterns such as drum or bass phrases, or guitar or keyboard backing riffs (VNL).

U200 (E-A) – U311 (E-G)

With the factory settings, these do not contain patterns.

U312 (User) – U506 (User)

When the TRITON STUDIO is shipped from the factory, arpeggio patterns are preloaded in some of these memories.

④ Adjust the settings of the various parameters.

“**Octave**”: Selects the octave range in which the arpeggio will be played.

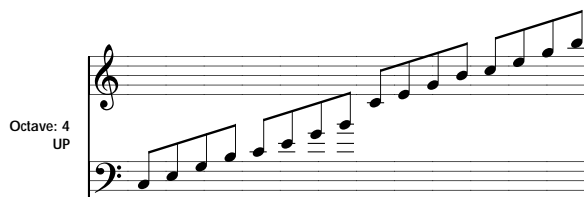

🔧 If a user arpeggio pattern is selected, the “Octave Motion” setting (Global P6: Arpeggio, Pattern Setup page) will affect the way in which the arpeggio is played.

“**Resolution**”: Specifies the timing value of the arpeggio notes over a range of $\frac{1}{3}$ - $\frac{1}{1}$.

“**Gate**”: Specifies the length (gate time) of each note in the arpeggio. If a user arpeggio pattern is selected, you can set this to **Step**. In this case, the value of the “Gate” setting for each step (Global P6: User Arpeggio, Pattern Edit page) will be used.

🔧 This value will be in effect when the ARPEGGIATOR [GATE] knob is in the center position (12 o'clock). Be sure that the knob is in the center position when you make this setting.

“**Velocity**”: Specifies the velocity of the notes in the arpeggio. If this is set to **Key**, the velocity with which you actually played each note will be used. If a user arpeggio pattern is selected, you can set this to **Step**. In this case, the value of the “Vel” setting for each step (Global P6: User Arpeggio, Pattern Edit page) will be used.

🔧 This value will be in effect when the ARPEGGIATOR [VELOCITY] knob is in the center position (12 o'clock). Be sure that the knob is in the center position when you make this setting.

📌 When a preload user arpeggio pattern is selected, setting the “Gate” or “Velocity” to **Step** will add a sense of groove to the arpeggio pattern.

“**Swing**”: This adjusts the timing of the even-numbered notes in the arpeggio (counting from the first note), to give the pattern a sense of “swing.”

“**Sort**”: If this is **checked**, the arpeggio will be sounded in order of pitch, regardless of the order in which notes were played on keyboard (On). If this is **unchecked**, the arpeggio will be sounded in the order in which the notes were played on keyboard (Off).



“**Latch**”: If this is **checked**, the arpeggio will continue playing even after you take your hand off the keyboard. If this is **unchecked**, the arpeggio will stop playing when you take your hand off the keyboard.

“**Key Sync.**”: If this is **checked**, the arpeggio pattern will start from the beginning when you play a note after having released all notes. This setting is suitable when you are playing in realtime, and want the arpeggio to start at the beginning of the measure. If this is **unchecked**, the arpeggio pattern will always be synchronized to the tempo of the MIDI clock. For details on synchronization, refer to “Synchronizing the arpeggiator” (p.138).

“**Keyboard**”: If this is **checked**, the notes you play on the keyboard will be heard as well as the arpeggiated notes. If this is **unchecked**, only the arpeggiated notes will be heard.

The same setting can be made by editing the parameter of the same name (or abbreviation) in the Program P0: Play, Arpeggio page.

📌 You can use the page menu command “Copy Arpeggiator” to copy arpeggiator settings from another program or combination (p.27).

⑤ In the Scan Zone page, specify the range in which the arpeggiator will operate.

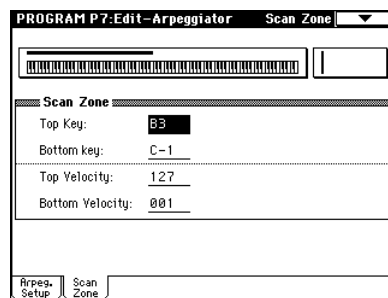

“**Bottom Key**,” “**Top Key**”: The arpeggiator will operate when you play keys within the specified range. Keys outside of this range can be played in the normal manner, and will not be affected by the arpeggiator on/off.

📌 For example if you set “Pattern” to **P000: UP**, check “Latch,” set “Top Key” to **B3**, and “Bottom Key” to **C-1**, playing a note B3 or lower will trigger the arpeggiator. Since “Latch” is **on**, the arpeggio will continue even after you release the keys. You can use the C4 and higher keys to play conventionally along with the arpeggio sounded by the B3 and lower keys. To change the arpeggio, play keys in the range of B3 and below.

“**Bottom Velocity**” “**Top Velocity**”: The arpeggiator will operate when you play notes with a velocity (playing strength) that is within the specified range. Notes played with a velocity outside this range will be sounded normally, without regard to the arpeggiator on/off.

⑤ If you wish to save the edited program settings to internal memory, turn off memory protect in Global mode, and write the program (p.57).

Linking the arpeggiator to a program

If you want the arpeggiator settings written in a program to be selected when that program is selected, check **Program** for “Auto Arpeggiator” (Global P0: Basic Setup, Basic page).

Arpeggiator settings in Combination and Sequencer modes

In Combination, Sequencer and Song Play modes, the TRITON STUDIO provides **dual arpeggiator** functionality that lets you use two arpeggio patterns simultaneously. The settings in each of these modes are made in the similar way.

As an example, the following explanation shows how to make settings in Combination mode. For a detailed explanation and example settings (PG p.45, 81, 129).

The dual arpeggiator functionality lets you do the following things.

- Assign an arpeggiator for each timbre. Choose from **Off**, (arpeggiator) **A**, or (arpeggiator) **B**. step ⑤
- Independently specify whether **A** and **B** will operate. step ⑥
- Select an arpeggio pattern and set parameters independently for **A** and **B**. step ⑦
- Make Scan Zone page settings so that you can use keyboard range or playing velocity to switch between normal playing and arpeggiated playing, or to switch between arpeggiators **A** and **B**. step ⑧
- Make settings for timbres that will be silent when the arpeggiator is Off, and will sound only when the arpeggiator is On. step ⑩

Arpeggiator on/off

Each time you press the ARPEGGIATOR [ON/OFF] key, the arpeggiator will be switched on or off. When on, the ARPEGGIATOR [ON/OFF] key LED will light. The selected arpeggio pattern will begin when you play the keyboard. The on/off setting is saved when the combination is written into memory.

- ▲ If “Assign” is Off or “Arpeggiator Run” is not checked, the arpeggiator will not operate even if this key is on.

Arpeggiator settings

① Select Combination P1: Edit-Program/Mixer page.

Select programs for the timbres that you wish to use. For this example, select any desired program for timbres 1–4.

② Select Combination P2: Edit-Trk Param, MIDI Ch page.

For the timbres that you will be using, set “Status” to **INT**, and set “MIDI Channel” to **Gch** or to the global MIDI channel (set in Global P1: MIDI “MIDI Channel”).

For this example, set timbres 1–4 to a “Status” of **INT**, and timbres 5–8 to a “Status” of **Off**. Set the “MIDI Channel” of timbres 1–4 to **Gch**.

COMBINATION P2:Edit-Trk Param MIDI Ch							
Bank EXB-A: 000: InitialCombEA000							
T01	A	B	E	E	E	E	Ch:Gch
T01: A001:Acoustic Piano							
Keyboard/Organ	Bell/Mall/Strings	FastSun	FastSun	FastSun	FastSun	FastSun	FastSun
Status							
INT	INT	INT	INT	Off	Off	Off	Off
MIDI Channel							
Gch	Gch	Gch	Gch	05	06	07	08
Bank Select (When Status=EX2)							
[0]	[0]	[0]	[0]	[0]	[0]	[0]	[0]
[0]	[0]	[0]	[0]	[0]	[0]	[0]	[0]
MIDI Channel							
	OSC		Pitch				Other

③ Select Combination P7: Edit-Arp., Setup page.

COMBINATION P7:Edit-Arp. Setup							
Bank EXB-A: 000: InitialCombEA000							
J = 120							
T01	A	B	E	E	E	E	Ch:Gch
T01: A001:Acoustic Piano							
Keyboard/Organ	Bell/Mall/Strings	FastSun	FastSun	FastSun	FastSun	FastSun	FastSun
Arpeggiator Assign							
A	A	B	Off	Off	Off	Off	Off
Arpeggiator Run: <input checked="" type="checkbox"/> A <input checked="" type="checkbox"/> B							
Setup							
	Arpegg. A	Arpegg. B	Scan Zone				

④ Set “J (Temp)” to specify the tempo.

This is the same as for a program (p.130). However, the tempo is shared by both arpeggiators **A** and **B**.

⑤ Make “Arpeggiator Assign” settings.

Assign arpeggiator **A** or **B** to the desired timbres. Each timbre will be played by the arpeggiator that has been assigned to it.

⑥ Make “Arpeggiator Run” settings.

Check the arpeggiator(s) that you want to operate. The arpeggiator(s) checked here will run when the ARPEGGIATOR [ON/OFF] key is turned on.

With the settings shown in the LCD screen for steps ② and ③, turning the ARPEGGIATOR [ON/OFF] key on will cause arpeggiator **A** to operate for timbres 1 and 2, and arpeggiator **B** to operate for timbre 3. When the ARPEGGIATOR [ON/OFF] key is turned off, timbres 1–4 will sound as a layer.

If all timbres “Assign” are Off, or if “Arpeggiator Run” **A** or **B** is unchecked, the arpeggiator will not function.

⑦ In the Arpeggiator A and Arpeggiator B pages, set the parameters for arpeggiators **A** and **B**.

The parameters for **A** and **B** are the same as for a program (p.130).

⑧ In the Scan Zone A/B page, specify the range in which arpeggiators **A** and **B** will operate.

The parameters for **A** and **B** are the same as for a program (p.130).

You can use keyboard ranges or playing velocity to operate the arpeggiator, or to switch between arpeggiators **A** and **B**. By using the Combination P4: Edit-Zone/Ctrl, Key Zone page, and Vel Zone page to set keyboard ranges and velocity ranges in conjunction with each other, you can create even more variations.

⑨ If you wish to save the edited combination settings in internal memory, turn off memory protect in Global mode, and write the combination. (p.57).

- ⑩ The “Status,” “MIDI Channel” and “Assign” settings shown in the LCD screen of steps ② and ③ can be made so that certain timbres will sound only when the arpeggiator is On, and will be silent when the arpeggiator is Off.

Although this is a somewhat sophisticated editing technique, we will describe the settings of one of the preset combinations as an example.

Combination INT-D080: Old Vox Organ

Select combination INT-D080: Old Vox Organ, and play it.

Before you play, make sure that the global MIDI channel (Global P1: MIDI “MIDI Channel”) is set to **01**.

- Arpeggiator **A** is assigned to **T** (timbre) **7** and **8**. When you play the keyboard, the arpeggio pattern **U396(User): Dr-Jump Up DnB** will sound only the **T7** program **INT-A068: HipHop Kit**.
- The arpeggio pattern uses **Fixed Note** mode, which is suitable for playing drums from the arpeggiator (**Global P6: User Arpeggio, Pattern Setup page “Arpeggio Tone Mode” Fixed Note**).
With this setting, the arpeggio pattern will always play the specified pitches regardless of the note numbers received from the keyboard. (≡PG p.152)
- The **A** “Bottom Key” and “Top Key” (Combination P7: Edit-Arp., Scan Zone A/B page) are set so that arpeggiator **A** will operate only for notes **B3** and lower.
- Arpeggiator **A** is also assigned to **T8**, but this is so that the **T7** program **INT-A068: HipHop Kit** will sound only when the arpeggiator is on.

Notice the timbre settings for T7 and T8

	Status	MIDI Channel	Assign
T7	INT	02	A
T8	Off	Gch	A

- If the arpeggiator is off, playing the keyboard will sound the timbre(s) that are set to **Gch** or to the global MIDI channel (in this case, **01**). Since the “MIDI Channel” of **T7** is set to **02**, it will not sound. **T8** is set to **Gch**, but since “Status” is **Off** it will not sound.
- Any MIDI channel that is assigned to a timbre will trigger the arpeggiator. In this case, these will be “MIDI Channel” **02** and **Gch** (global MIDI channel). When the arpeggiator is on, playing the keyboard will trigger arpeggiator **A** which is assigned to **T8 (Gch)**. **T7** will be sounded by arpeggiator **A**. Since the “Status” of **T8** is **Off**, it will not sound.
- Since the “Status” of **T8** is **Off**, it will not sound, regardless of whether the arpeggiator is on or off. It is a dummy timbre that causes **T7** to sound only when the arpeggiator is on.

Combination INT-C005: “In The Pocket”

Select and play combination INT-C005: “In The Pocket.”

Before you play, make sure that the global MIDI channel (Global P1: MIDI “MIDI Channel”) is set to **01**.

- Arpeggiator **A** is assigned to **T7** and **T8**, and arpeggiator **B** is assigned to **T5**. When you play the keyboard, the **T7** program **INT-A068: HipHop Kit** will be sounded by the arpeggio pattern **U444(User): Dr-In The Pocket**. The **T5** program **INT-D034: Chord Trigger** will be sounded by the arpeggio pattern **U123(I-A/B): Syn-Echo**.
- The **B** “Bottom Key” and “Top Key” (Combination P7: Edit-Arp., Scan Zone page) are set so that arpeggiators **B** will operate only for the **G3** note and above.
- Arpeggiator **B** is assigned to **T8** as well, but this setting is so that the **T7** program **INT-A068: HipHop Kit** will sound only when the arpeggiator is on. Refer to the preceding section “Select and play Combination INT-D080: Old Vox Organ.”

Linking the arpeggiator to the combination

If you want the arpeggiator settings of a combination to become active when that combination is selected, **check** Combination for “Auto Arpeggiator” (Global P0: Basic Setup, Basic page).

Creating an user arpeggio pattern

About user arpeggio patterns

The patterns that can be selected on the TRITON STUDIO's arpeggiator are called "arpeggio patterns." There are two types of arpeggio patterns: preset arpeggio patterns and user arpeggio patterns.

Preset arpeggio patterns:

There are five patterns; UP, DOWN, ALT1, ALT2, and RANDOM.

The operation of these patterns is fixed, and cannot be edited.

User arpeggio patterns:

There are 507 patterns - U000(I-A/B)-U506(User) - which can develop chords or phrases in a wide variety of ways, based on the pitches that you play on the keyboard or the timing at which you play them.

In Global P6: User Arpeggio, Pattern setup you can modify these user arpeggio patterns, or create a new user arpeggio pattern from an initialized condition. Edited user arpeggio patterns can be written to internal memory areas U000(I-A/B)-U506(User) (p.58).

In Disk mode, user arpeggio patterns can also saved to media such as a floppy disk or the internal hard drive.

Editing a user arpeggio pattern

If you want to edit a user arpeggio pattern, you must first make sure that memory protect is unchecked. (p.57)

If you enter this mode from the Program mode, your editing will apply to the arpeggio pattern specified for the selected program.

① In Program mode, select a program for which the arpeggio pattern you wish to edit is selected, or a program that you wish to use as a basis for editing the arpeggio pattern.

② Press the ARPEGGIATOR [ON/OFF] key to turn the arpeggiator on (the LED will light).

Even if you moved to Global mode from a program in which the arpeggiator was turned off, you can use the ARPEGGIATOR [ON/OFF] key to turn it on.

③ Select the Global P6: User Arpeggio, Pattern Setup page.

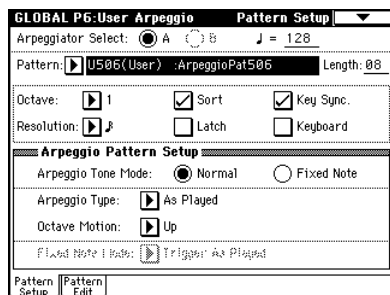

④ "Arpeggiator Select" will automatically be set to A when you move here from Program mode.

⑤ In "Pattern," select the arpeggio pattern that you wish to edit.

For this example, select an empty user arpeggio pattern.

If a blank pattern is selected, playing the keyboard will not start an arpeggio. Although preset arpeggio patterns P000-P004 can be selected, they cannot be edited.

When you edit a user arpeggio pattern, the changes will have an effect anytime that this pattern is used in Program, Combination, Song or Song Play modes.

⑥ In "Length," specify the length of the pattern.

After the pattern has played for the length specified, it will return to the beginning. This setting can also be changed during or after editing. For this example, set it to 08.

For the preload arpeggio patterns U000(I-A/B)-U199(I-A/B), simply changing the "Length" can significantly change the character of the pattern. Try changing the length and listening to the result.

⑦ Make settings for the "Tempo," "Resolution," "Octave," "Sort," "Latch," "Key Sync.," and "Keyboard" parameters.

These are program parameters, but can be set from here as well.

If after moving here from Program mode, you modify these parameters and wish to keep your changes, return to Program mode and write the program. These parameters are not saved by "Write Arpeggio Pattern."

For this example, make the settings shown in the LCD screen on step ③.

⑧ In Arpeggio Pattern Setup, specify how the arpeggio will be developed.

These settings can be changed during or after editing (PG p.152).

⑨ Select the Pattern Edit page.

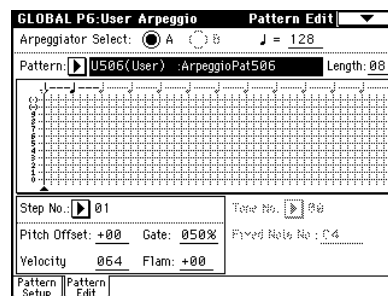

A pattern consists of Steps and Tones.

• **Step:** A user arpeggio pattern can have a maximum of 48 steps. The arpeggiator will play from the first step, in steps equal to the timing value specified by "Resolution." The vertical lines of the grid shown in the center of the LCD screen indicate the steps. Use "Step No." to select the step. For each step, specify "Pitch Offset," "Gate," "Velocity" and "Flam."

- **Tone:** At each step, a chord consisting of up to 12 tones (Tone No. 00–11) can be sounded.

To input tones, select “Step No.” and then use numeric keys [0]–[9], [-], and [./10’s HOLD] to input tones. The “Tone No.” corresponds to the [0]–[9], [-], and [./10’s HOLD] keys as shown below. Each time you press a [0]–[9], [-], or [./HOLD] key, the corresponding tone will be turned on/off. The horizontal lines of the grid shown in the center of the LCD screen indicate the tones.

- Tone00–09:** [0]–[9] keys
- Tone10:** [-] key
- Tone11:** [./10’s HOLD] key

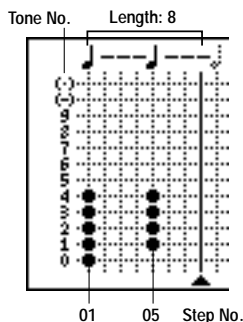

Creating an example pattern



- ① Set “Step No.” to 01, and press the [0] key.
- ② Set “Step No.” to 02, and press the [1] key.
- ③ Set “Step No.” to 03, and press the [2] key.
- ④ Set “Step No.” to 04, and press the [1] key.
- ⑤ Set “Step No.” to 05, and press the [3] key.
- ⑥ Set “Step No.” to 06, and press the [1] key.
- ⑦ Set “Step No.” to 07, and press the [2] key.
- ⑧ Set “Step No.” to 08, and press the [1] key.

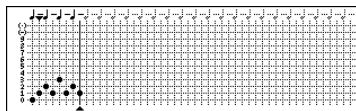

- ⑨ When you play the keyboard as shown in the illustration, the arpeggiator will begin playing.

Tone 0 corresponds to the pitch of the lowest key of chord you play on the keyboard. (If “Sort” is unchecked, it will correspond to the pitch of the first note you play.)

- ⑩ For steps 01–08, make settings for “Pitch Offset,” “Gate,” “Velocity,” and “Flam.”

“**Pitch Offset**”: This offsets the pitch of the arpeggio note in semitones up or down. You can input the same tone for each step, and change the “Pitch Offset” value for each to create a melody using a single tone. (See “Melody pattern”)

“**Gate**”: Specifies the length of the arpeggio note for each step. With a setting of **Legato**, the note will continue sounding either until the next note of the same tone or until the end of the pattern. With a setting of **Off**, the note will not sound.

“**Velocity**”: Specifies the strength of the note. With a setting of **Key**, the note will sound at the strength with which it was actually played.

- ⚠ The “Gate” and “Velocity” settings you make here will be valid if the “Gate” and “Velocity” parameters (Program P7: Edit-Arpeggiator, Arpeg. Setup page) of the program selected in Program mode are set to **Step**. If these parameters have a setting other than **Step**, the “Gate” and “Velocity” that were specified for each individual step will be ignored, and all notes of the arpeggio will sound according to the settings in Program P7: Edit-Arpeggiator. Be sure to verify the settings of the program.
- ⚠ Set the “Gate” and “Velocity” by using the ARPEGGIATOR [GATE] and [VELOCITY] knobs to the center position (12 o’clock).

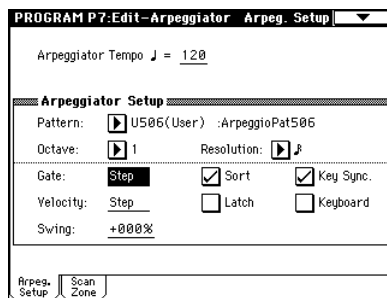

- ⑪ To change the user arpeggio pattern name, use the “Rename Arpeggio Pattern” page menu command (see p.57).
- ⑫ If you wish to save the edited user arpeggio pattern to internal memory, be sure to Write the user arpeggio pattern (see p.58).
If you turn off the power without writing, the edited contents will be lost.
- ⑬ If you wish to save the state of the program at the same time, return to Program mode and write the program (see p.56).

Other examples of creating a user arpeggio pattern

Melody pattern

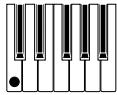

- ① Set "Step No." to 01, and press the [0] key. Set "Pitch Offset" to +00.
- ② Set "Step No." to 02, and press the [0] key. Set "Pitch Offset" to +10.
- ③ Set "Step No." to 03, and press the [0] key. Set "Pitch Offset" to +00.
- ④ Set "Step No." to 04, and press the [0] key. Set "Pitch Offset" to +00.
- ⑤ Set "Step No." to 05, and press the [0] key. Set "Pitch Offset" to +12.
- ⑥ For "Step No." 06, do not enter a tone.
- ⑦ Set "Step No." to 07, and press the [0] key. Set "Pitch Offset" to +00.
- ⑧ Set "Step No." to 08, and press the [0] key. Set "Pitch Offset" to -02.

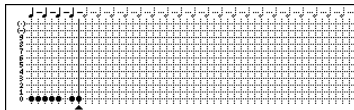

Chordal pattern

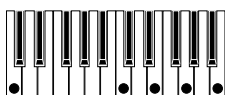

- ① Set "Step No." to 01, and press the [0] key. Set "Gate" to Legato.
- ② For "Step No." 02, do not enter a tone.
- ③ Set "Step No." to 03, and press the [1], [2], [3], [4] keys.
- ④ Set "Step No." to 04, and press the [1], [2], [3], [4] keys.
- ⑤ For "Step No." 05, do not enter a tone.
- ⑥ Set "Step No." to 06, and press the [1], [2], [3], [4] keys. Set "Gate" to Legato.
- ⑦ For "Step No." 07, do not enter a tone.
- ⑧ Set "Step No." to 08, and press the [1], [2], [3], [4] keys.

note To simulate the timing nuances of a strummed guitar chord, select "Flam." In Program mode, select an acoustic guitar program, and choose the user arpeggio pattern that you created here. In the Arpeg. Setup page of Program P7: Edit-Arpeggiator, set "Gate" to Step.

Then return to the Global P6: User Arpeggio, Pattern Edit page. For odd-numbered steps, set "Flam" to a positive (+) value. For even-numbered steps, set "Flam" to a negative (-) value.

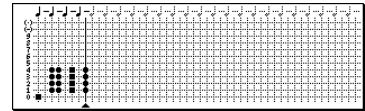

Drum pattern

You can use the arpeggiator to play a rhythm pattern by using "Fixed Note" with a drum program.

- ① In Program mode, select a drum kit program. For this example, select the preset program INT-A036: Standard Kit 1.
- ② In Global P6: User Arpeggio, select the Pattern Setup page, and make Arpeggio Pattern Setup settings. "Arpeggio Tone Mode": Set this to Fixed Note. This will cause the tone to always sound at the specified pitch. "Fixed Note Mode": If you set this to Trigger All Tones, playing a single note on the keyboard will sound all tones.

If you set this to Trigger As Played, the tones will be sounded according to the notes you play on the keyboard (PG p.152).

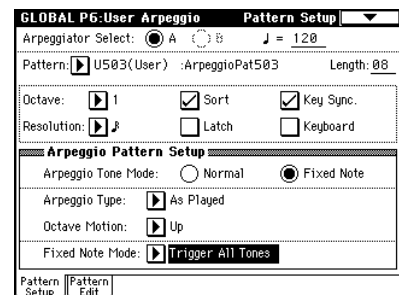

- ③ Select the Pattern Edit page.

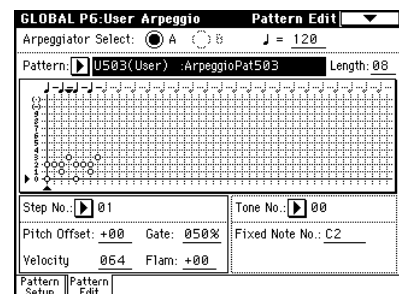

Let's input the following rhythm pattern.

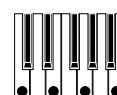
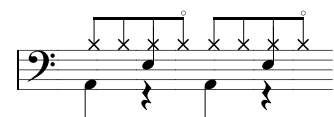

④ Make settings for “Tone No.” and “Fixed Note No.”

Select “Tone No.,” and set “Fixed Note No.” to the note number that will be sounded by that tone. For each horizontal line (Tone) in the screen, you will specify the drumsample (note number) of the drum kit. Each **Tone** will be displayed as a small circle.

For this example, set “Tone No.” and “Fixed Note No.” as follows.

Tone No.	Fixed Note No.
00	C2 (kick)
01	F2 (snare)
02	F#3 (closed hi-hat)
03	A#3 (open hi-hat)

The drumsamples that correspond to each note number will differ depending on the drum kit. It is convenient to audition the drum sounds from the keyboard, and then input “Fixed Note No.” by holding down the [ENTER] key and playing the desired key.

⑤ Input the kick (Tone00).

Set “Step No.” to 01, and press the [0] key. Then set “Step No.” to 05, and press the [0] key.

⑥ Input the snare (Tone01).

Set “Step No.” to 03, and press the [1] key. Then set “Step No.” to 07, and press the [1] key.

⑦ Input the closed hi-hat (Tone02).

Set “Step No.” to 01, 02, 03, 05, 06, and 07, and press the [2] key for each.

⑧ Input the open hi-hat (Tone03).

Set “Step No.” to 04, and press the [3] key. Then set “Step No.” to 08, and press the [3] key.

If “Fixed Note Mode” is set to **Trigger All Tones**, playing a single note on the keyboard will cause the rhythm pattern to play.

If “Fixed Note Mode” is set to **Trigger As Played**, playing a single note on the keyboard will cause only the kick (**Tone00**) to play.

Playing two notes on the keyboard will cause only the kick (**Tone00**) and snare (**Tone01**) to play. In this way, the number of keys that you play will be played by the same number of **tones**.

⑨ Set the parameters for each step.

Use “Velocity” etc. to add accents to the rhythm pattern.

 The “Gate” and “Velocity” settings you make here will be valid if the “Gate” and “Velocity” parameters (Program P7: Edit-Arpeggiator, Arpeg. Setup page) of the program selected in Program mode are set to **Step**. If these parameters have a setting other than **Step**, the “Gate” and “Velocity” that were specified for each individual step will be ignored, and the notes of the arpeggio will be sounded according to the settings of the Program P7: Edit-Arpeggiator, Arpeg. Setup page. Check the settings of the program.

 Set the “Gate” and “Velocity” by using the ARPEGGIATOR [GATE] and [VELOCITY] knobs to the center position (12 o'clock).

Dual arpeggiator editing

Here we will use a combination as an example in our explanation.

The same procedure applies when editing an arpeggio pattern in Sequencer and Song Play modes.

If you have entered this mode from the Combination mode, the arpeggio pattern selected by the combination will be affected by your editing.

① In Combination mode, select a combination that uses the arpeggio pattern you wish to edit.

For this example, select a combination to which both arpeggiators A and B are assigned.

② Press the ARPEGGIATOR [ON/OFF] key to turn on the arpeggiator (the LED will light).

Even if the arpeggiator had been turned off when you moved here, you can use the ARPEGGIATOR [ON/OFF] key to turn it on. However, if “Arpeggiator Run” A or B are not checked, and if “Arpeggiator Assign,” is set to off, then the arpeggiator will not operate.

③ Select the Global P6: User Arpeggio, Pattern Setup page.

④ If you moved here from Combination mode, use the “Arpeggio Select” A and B to select the arpeggiator that you wish to edit.

If this is A, your editing will apply to the parameters and user arpeggio pattern of arpeggiator A. If this is B, your editing will apply to the parameters and user arpeggio pattern of arpeggiator B.

⑤ Switch between arpeggiators A and B, and edit their respective user arpeggio patterns.

If you wish to stop one of the arpeggiators, return to Combination mode, and in Combination P0: Play, select the Arpeggio Play A or the Arpeggio Play B page and uncheck the “Arpeggiator Run” check box.

⑥ To modify the name of a user arpeggio pattern, use the Utility “Rename Arpeggio Pattern” (p.56).

⑦ If you wish to save the edited user arpeggio pattern in internal memory, you must write the user arpeggio pattern.

In this case, both user arpeggio patterns will be written simultaneously. If you turn off the power without writing, the edited contents will be lost (p.58).

⑧ If you wish to save the state of the combination at the same time, return to Combination mode and write the combination (p.56).

 When editing a user arpeggio pattern, pay attention to the global MIDI channel, the channel of each track, and the arpeggiator assignments, and make sure that the arpeggiator you are hearing is the pattern that you wish to edit.

 If you moved here from Sampling mode, the arpeggiator will not turn on. Nor will it be possible to edit arpeggio patterns.

Synchronizing the arpeggiator

The note timing of the arpeggiator will differ depending on the state of the arpeggiator “**Key Sync.**” check box. If this is **checked**, the arpeggiator will operate at the timing of the first note-on you play from a state in which all keys are released.

If this is **unchecked**, the arpeggiator will operate in synchronization with the internal or external MIDI clock.

The paragraphs below explain how synchronization occurs when the “**Key Sync.**” check box is **unchecked**. (However, synchronization with Song Start and with the MIDI realtime command Start message are exceptions to this.)

Synchronization between arpeggiators A and B

In Combination, Sequencer and Song Play modes, two arpeggiators can operate simultaneously. In this case, if you start an arpeggiator (whose “**Key Sync.**” is **unchecked**) while the other arpeggiator is already running, the arpeggiator you started will synchronize to the “♩ (Tempo)” based on the timing of the already-running arpeggiator.

note If “**Key Sync.**” is checked, A and B will each operate on their own timing.

Synchronization between the arpeggiators and sequencer in Sequencer or Song Play mode

When song playback is stopped

- The arpeggiator will synchronize to the “♩ (Tempo)” based on the timing of the internal MIDI clock.
- In Sequencer mode when an RPPR pattern is playing, the arpeggiator will synchronize to the beats of that pattern.
- In Sequencer mode if you want RPPR pattern playback to be synchronized to the currently-running arpeggiator, set “**Sync**” to **SEQ** (Sequencer P6:Pattern/RPPR, RPPR Setup page).

The pattern playback will synchronize to the “♩ (Tempo)” timing of the arpeggiator.

When a song is being played or recorded

- The arpeggiator will synchronize to the beats based on the timing of the song.

Synchronization with Song Start

- When the arpeggiator is on (the ARPEGGIATOR [ON/OFF] key is on) and running, receiving a Song Start message will reset the arpeggiator to the beginning of the pattern. (This has no relation to the “**Key Sync.**” setting.)
- In Sequencer mode when the “**Key Sync.**” setting is unchecked and the ARPEGGIATOR [ON/OFF] key is on, starting the arpeggiator by pressing notes during the pre-count before recording will cause the arpeggiator to start (and be recorded) from the

beginning of the arpeggio pattern at the moment that recording begins.

Synchronization with an external sequencer in Program, Combination, or Sequencer modes

In Program, Combination, and Sequencer modes when “♩ (Tempo)” is **EXT** (Global P1: MIDI “**MIDI Clock**” set to **External MIDI** or **External mLAN**), the TRITON STUDIO will synchronize to MIDI Clock and Start messages received from an external MIDI sequencer (or similar device) connected by a MIDI cable.

Synchronization to external MIDI clock

- The arpeggiator will synchronize to the “♩ (Tempo)” based on the timing of the external MIDI clock.

Synchronization to the MIDI Start message

- When the arpeggiator is on and operating, receiving a MIDI Start message will cause the arpeggiator to reset to the beginning of the pattern. (This has no relation to the “**Key Sync.**” setting.)

 In Song Play mode, the TRITON STUDIO will not synchronize to an external MIDI clock.

Effects settings

The effect section of the TRITON STUDIO provides five **insert effects**, two **master effects**, one **master EQ** (stereo 3-band EQ), and a **mixer** that controls the routing of these components.

You can choose from 102 types of full-digital effects for each insert effect, and from 89 types for each master effect. The effects are categorized as follows.

Categories of the 102 effect types

001–015	Filter and dynamics effects, such as EQ and compressor
016–031	Phase modulation effects, such as chorus and phaser
032–040	Other modulation and pitch-shift effects such as rotary speaker and pitch shifter
041–051	Early reflection and delay effects
052–057	Reverb effects
058–089	Mono + mono chain effects that internally connect two mono effects in series
090–102	Double-size effects

⚠ Effects **000–089** can be selected for IFX1, 2, 3, 4, 5, or MFX 1 or 2. Effects **090–102** are double-size effects, and will use twice the processing area of other effects. They can be selected for IFX2, IFX3 or IFX4.

Effects in each mode

In **Program mode**, insert effects can be used as part of the sound-creating process, in the same way that the output sound of the oscillator (OSC) is processed by the filter and amp to create the final sound. Then the master effects can be used to apply spatial-type effects such as reverb. The stereo 3-band master EQ is located immediately before the OUTPUT (MAIN) L/MONO and R outputs and is used to make final adjustments in tone. These settings can be made independently for each program.

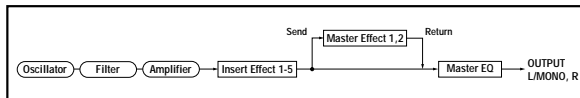

In **Combination mode**, **Sequencer mode**, and **Song Play mode**, insert effects can be used to help create the sound of each timbre/track. The master effects are used to apply overall spatial processing, and the master EQ is used to make overall adjustments in tone.

These settings are made in Combination mode independently for each combination, in Sequencer mode for each song, and in Song Play mode for the entire mode.

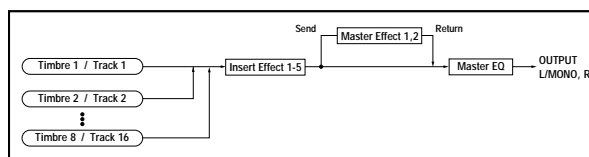

In **Sampling mode**, you can sample while applying insert effects to the audio coming in via AUDIO INPUT 1, 2, S/P DIF IN, or mLAN (if the EXB-mLAN is installed) jacks.

Settings in Sampling mode are made in **Input (SAMPLING)** (Sampling P0: Input/Setup). These settings are valid only for Sampling mode.

You can also sample while applying an insert effect to the samples assigned to a multisample.

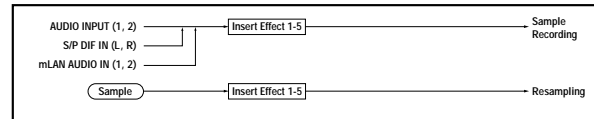

The external input from the AUDIO INPUT 1, 2, S/P DIF IN, or mLAN (if the EXB-mLAN option is installed) jacks is also valid in modes other than Sampling mode. In Program, Combination, Sequencer, and Song Play modes, you can use the insert effects, master effects, and master EQ. Settings for external signal input via the AUDIO INPUT 1, 2, S/P DIF IN, and mLAN (if the EXB-mLAN option is installed) can be made in "Input (COMBI, PROG, SEQ, S.PLAY, DISK)" (Global P0: 0–3a).

In these modes, the external input sound from each jack can be processed by the TRITON STUDIO's effects and sampled, or the TRITON STUDIO can be used as a 6-in 6-out effect processor. The TRITON STUDIO can also be used as a vocoder effect (093: Vocoder) that uses external mic input to control internal sounds.

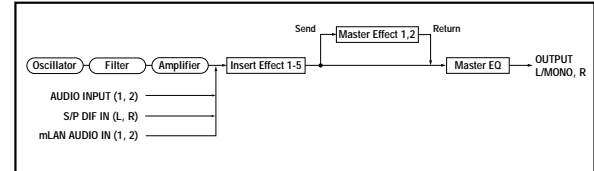

⚠ When effects are applied to the external input sound from the AUDIO INPUT 1, 2, S/P DIF IN, and mLAN (if the EXB-mLAN option is installed) jacks, certain effect types or parameter settings may cause oscillation to occur. If this occurs, adjust the input level, output level, or effect parameters. Please be aware of this particularly when using an effect that has a high gain.

Routing settings and effect settings

The insert effects, master effects, and master EQ have the same structure in all modes, but the routing settings will determine how the oscillators of a program or the timbres of a combination or track of a song will be sent to each insert effect or master effect. In the pages that follow, we will explain how you can make routing settings and effect settings in each mode.

Effect settings for a program

Routing

- In Program P8: Edit-Insert Effect, select the Routing page.

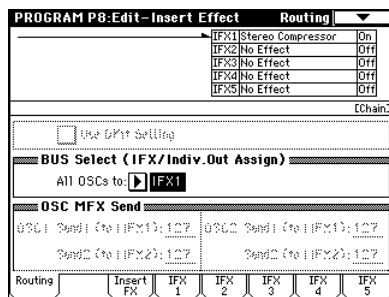

- Use “BUS Select (IFX/Indiv.Out Assign) to specify the bus (insertion effect) to which the output of the oscillator will be sent.

L/R: The output will not be sent to the insert effects. After passing through the master EQ, the sound will be sent to AUDIO OUTPUT (MAIN) L/MONO and R.
IFX1–5: The output will be sent to insert effect IFX 1, 2, 3, 4, or 5.

1, 2, 3, 4, 1/2, 3/4: The output will be sent to AUDIO OUTPUT (INDIVIDUAL) 1, 2, 3, or 4. It will not be sent to the insert effects, the master effects, or the master EQ.

Off: The output will not be sent to AUDIO OUTPUT (MAIN) L/MONO, R, or to (INDIVIDUAL) 1, 2, 3, 4. (After passing through the master effects, it will be output from AUDIO OUTPUT (MAIN).) Select this when you wish to connect the output to the master effects in a series connection at the send levels specified by “Send 1 (MFX1)” and “Send 2 (MFX2).”

- OSC MFX Send** specifies the send level from each oscillator to the master effects.

This can be set only when “BUS Select (IFX/Indiv.Out Assign)” is either L/R or Off.

If “BUS Select (IFX/Indiv.Out Assign)” is set to IFX1–5, the send level to the master effects is set by “Send 1” and “Send 2” (Insert FX page) after the signal passes through the insert effects.

Insert effects

- Select the Insert FX page.

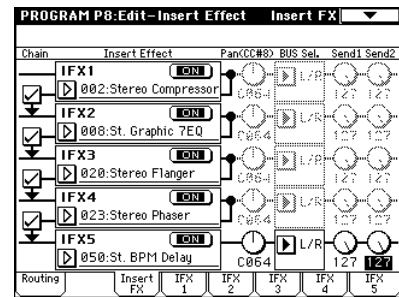

- For IFX1–5, select the effect type for each insert effect.

note When you press the popup button, all effects will be displayed, organized into six categories. Use the pages located at the left to select a category, and select an effect from that category on the LCD screen.

! Effects 000–089 can be selected for IFX1, 2, 3, 4, 5, and MFX1 and 2.
 Effects 090–102 are double-size effects, and require twice the processing area of other effects. These can be selected for IFX2, IFX3, and IFX4.

note You can use the “Copy Insert Effect” page menu command to copy effect settings from another program etc. Also, you can use “Swap Insert Effect” to exchange (for example) IFX1 and IFX5.

- Press the ON/OFF button to turn on the insert effect.

Each time you press the button, the insert effect will be switched on/off. When OFF, the result will be the same as when 000: No Effect is selected. The input sound will be output without change.

- Make “Chain” settings.

If the “Chain” check box is checked, the insert effect will be connected in series. Since the output of the oscillator is being sent to IFX1 in ②, making settings as shown in the diagram ④ would connect all five insertion effects IFX1 → IFX2 → IFX3 → IFX4 → IFX5 in series, so that these effects would be inserted into the output of the oscillator.

- Make settings for “Pan (CC#8),” “BUS Sel. (BUS Select),” “Send 1,” and “Send 2” for the sound after it has passed through the insert effects.

If the insert effects are chained, these settings will apply after the last IFX.

“Pan”: Sets the pan. This is valid only when BUS Sel. is L/R.

“BUS Sel.” (BUS Select): Specifies the output destination. Normally you will set this to L/R. If you wish to send the sound that has passed through the insert effects to AUDIO OUTPUT (INDIVIDUAL) 1–4, select 1–4, 1/2, or 3/4.

“Send 1,” “Send 2”: Sets the send levels to the master effects. For this example, set this to 127.

- Select the IFX1–5 pages, and set the parameters for each of the selected effects.

For details on the parameters of each effect (PG p.187–).

Master effects

The input levels to the master effects are set by the “Send 1, 2” levels (step ③ or ⑧). If “Send 1, 2” are zero, the master effects will not apply. “Send 1” corresponds to MFX1, and “Send 2” corresponds to MFX2.

- ⑩ In Program P9: Edit-Master Effect, select the Master FX page.

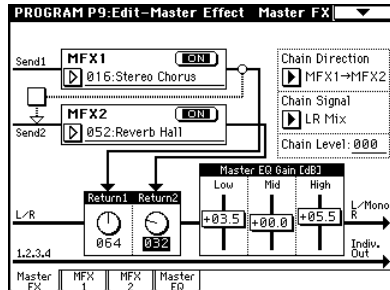

- ⑪ In MFX1 and MFX2, select the type of each master effect.

The procedure is the same as when selecting an insertion effect (step ⑤).

- ⚠ The master effects cannot use double-size effects.
- ⚠ The master effects are mono-in/stereo-out. Even if a stereo-input effect is selected, it will function as mono input.
- ⑫ Press the ON/OFF button to turn on the master effect. Each time you press the button, the master effect will be switched on/off. When OFF, the output of the master effect will be muted.
- ⑬ Use “Return 1” and “Return 2” to adjust the output levels of the master effects.
- ⚠ For each effect, the Wet value of the “Wet/Dry” parameter is the output level at the effect. The return value is multiplied with this (“Return” = 127 will be x1.0) to determine the actual output level of the master effect.
- ⑭ Select the MFX1 and MFX2 pages, and set the parameters for each selected effect.

For details on the parameters of each effect (PG p.187-).

Master EQ

- ⑮ Use the stereo 3-band master EQ to make final equalizing adjustments immediately before the sound is output to the AUDIO OUTPUT L/MONO and R jacks.

Move the slider for each band to make adjustments. You can select the Master EQ page, and adjust the band frequency of the master EQ (PG p.239).

Effect settings in Combination, Song, and Song Play modes

In Combination, Sequencer, and Song Play modes, you can specify the routing of each timbre/track to the insert effects and master effects. These settings are made in the same way in each of these modes. We will be using the example of Combination mode in our explanation here.

Routing

- ① In Combination P8: Edit-Insert FX, select the Routing page.

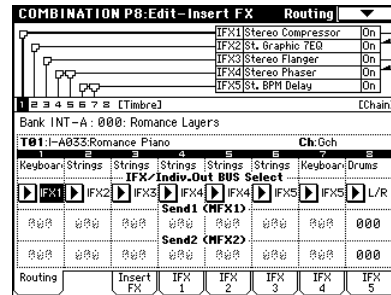

- ② Select “IFX/Indiv.Out BUS Select.” Here you can specify the bus (insert effect) to which the output of each timbre will be sent.

The routing, insert effects, and chain settings are shown graphically in the upper part of the display screen. In this example, T01 (timbre 1) uses IFX1 and 2. T02 uses IFX2, T03 uses IFX3 and 4, T02 and T05 use IFX4, and T06 and T07 use IFX5. Selection of each effect type, the on/off setting, and chain settings are made in the Insert Effect page.

- ③ “Send1,” “Send2” specifies the send level from each timbre to the master effects.

This can be set only if “IFX/Indiv.Out BUS Select” is set to L/R or Off.

- ⚠ The actual send level is determined by multiplying this by the “Send 1” or “Send 2” settings for oscillators 1 and 2 within the program selected by the timbre. If the program parameter “Send 1” or “Send 2” is set to 0, the resulting level will still be 0 even if you raise this send level.

If “IFX/Indiv.Out BUS Select” is set to IFX1-5, the send levels to the master effects are set by “Send 1” and “Send 2” (Insert FX page) following the insert effects.

Insert effects

Select an effect for IFX1-IFX5, and set “Pan (CC#8),” “BUS Sel. (BUS Select),” “Send 1” and “Send 2” for the signal that has passed through each insert effect. If effects are chained, the settings after the last IFX in the chain will be used. “Send 1” and “Send 2” adjust the amount of master effect that is applied to the signal that has passed through the IFX. These settings can be made in the same way as for a program (PG p.140).

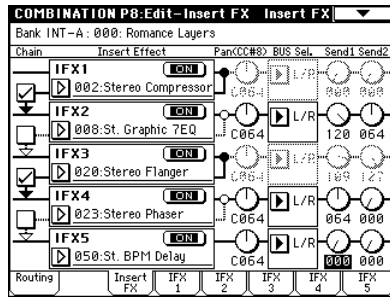

Insert effects

Select an effect for IFX1-IFX5, and set “Pan (CC#8)” for the signal that has passed through each insertion effect. If effects are chained, the settings after the last IFX in the chain will be used.

Master effects

Master EQ

The master effects and master EQ cannot be used in Sampling mode.

Master effects

Master EQ

These settings can be made in the same way as in “Effect settings for a program” (p.141).

Effect settings in Sampling mode

In Sampling mode, you can apply an insert effect to an external audio source that is input from AUDIO INPUT 1, 2, S/P DIF IN, or mLAN (if the EXB-mLAN option is installed), or to audio from an audio CD (if the CDRW-1 option is installed), and sample the result. You can also apply an insert effect to the samples assigned to a multi-sample, and resample the result.

Routing

- Use “Input (SAMPLING)” to specify the external audio input, and set the Sampling P0: Recording, Input/Setup page “BUS (IFX/Indiv.) Select” parameter to specify the bus (i.e., the insert effect) to which the signal will be sent. (p.39)

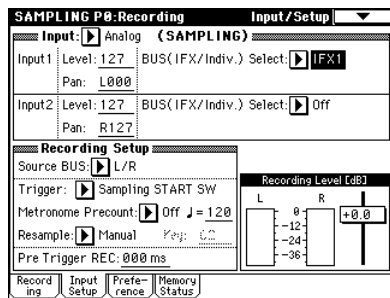

note The Input settings allow you to input simultaneously from each input source.

The bus (the insert effect) to which the samples assigned to the multisample will be sent is specified by the Sampling P8: Insert Effect, Routing page “BUS Select (Indiv.Out Assign)” parameter. (p.107)

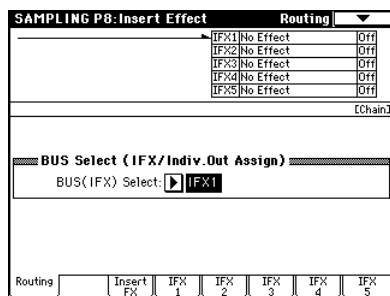

Effect settings for AUDIO INPUT

In Program, Combination, Sequencer, Song Play, and Disk modes, external audio sources can be input from the AUDIO INPUT 1, 2, S/P DIF IN, and mLAN (if the EXB-mLAN option is installed) jacks, or from an audio CD inserted in the CDRW-1 option (if installed), and processed by the TRITON STUDIO's effects. In these modes, the insert effects, master effects, and master EQ can be used. Settings for the external audio input from each AUDIO INPUT 1, 2, S/P DIF IN, and mLAN (if the EXB-mLAN option is installed) jack can be made in "Input (COMBI, PROG, SEQ, S.PLAY, DISK)." Normally, you will make these settings in the Global mode P0: Basic Setup, Input/Sampling page, but you can also make them in Combination, Program, Sequencer, or Disk modes. In these modes, you can apply the TRITON STUDIO's effects to the external audio signals from each jack and sample the result, or use the TRITON STUDIO as a 6-in (AUDIO INPUT 1, 2, S/P DIF IN L, R, mLAN 1, 2) 6-out effect processor. You can also use it as a vocoder effect (093: Vocoder) in which internal sounds are controlled by an external mic input.

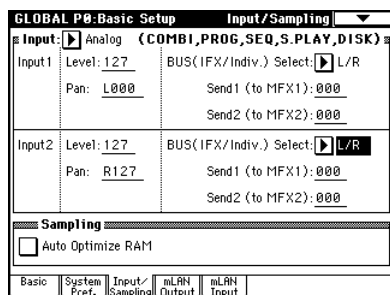

Routing

In Program, Combination, Sequencer, Song Play, and Disk modes (i.e., in other than Sampling mode), the routing of the external audio input signals from the various jacks is specified by "BUS (IFX/Indiv.) Select."

- 1 Use "Input (COMBI, PROG, SEQ, S.PLAY, DISK)" to select the source that you want to input.

This setting can be made in any of the following pages. If you want to save the edited settings into internal memory, you must write them. Use the Global mode page menu command "Write Global Settings."

Program, Combination	P0: Play, Sampling page
Sequencer	P0: Play, Sampling page
Global	P0: Basic Setup, Input/Sampling page
Disk	Play Audio CD page

note Input-related settings are shared between all of the above modes. For each input source that you select in "Input (COMBI, PROG, SEQ, S.PLAY, DISK)," a routing can be specified independently. If desired, you may input simultaneously from all input sources.

- If you want to make these settings in Global mode, move to Global mode from the mode (other than Sampling mode) in which you will be inputting the external audio signals. If you move from Sampling mode to Global mode, the *Input (SAMPLING)* settings of Sampling mode will be maintained, and it will not be possible to view the settings of this page. These settings are ignored in Sampling mode. Audio

input settings for Sampling mode are made in a similar way, in Sampling P0: Recording, Input/Setup page *Input (SAMPLING)*.

- When you apply effects to external input signals from the AUDIO IN 1, 2, S/P DIF IN, and mLAN inputs, oscillation may be heard depending on the type of effect and the parameter settings of the effect. If this occurs, adjust the input level, output level, and effect parameters. Particular care should be taken when using high-gain effects.

- 2 Set the parameters for *Input1* and *2*.

Input1 and *2* correspond to the following inputs.

Analog	AUDIO INPUT 1 2	Input1 Input2
S/P DIF	S/P DIF Lch Rch	Input1 Input2
mLAN	mLAN 1 2	Input1/Input2 Input1/Input2

"Level": Sets the level of the input signal that you selected in "Input (COMBI, PROG, SEQ, S.PLAY, DISK)." Normally you will set this to 127. If the sound is distorted even though you lower this setting significantly, it is possible that the sound is distorting before the AD converter. Adjust the [LEVEL] knob or the output level of the external audio source.

"Pan": Sets the pan of the input signal that you selected in "Input." When inputting a stereo audio source, you will normally set *Input1* to L000, and *Input2* to R127 (or Input1 to R127 and Input2 to L000). When inputting a mono audio source, you will normally set this to C064.

"BUS (IFX/Indiv.) Select": In the same way as when making settings for the oscillator(s) of a program, Specifies the bus to which each external audio input will be sent. (p.140)

"Send1 (to MFX1)," "Send2 (to MFX2)": In the same way as when making settings for the oscillator(s) of a program, sets the master effect send levels for each external audio input. This can be set only if "BUS (IFX/Indiv.) Select" is set to L/R or Off. (p.141)

If "BUS (IFX/Indiv.) Select" is set to IFX1-5, the master effect send levels are set by the "Send1" and "Send2" parameters following the insert effect (in each Insert FX page).

- If "BUS (IFX/Indiv.) Select" has a setting other than Off, and you raise the "Level" value, the external audio source will be input to the TRITON STUDIO. At this time if audio cables are connected to the rear panel AUDIO INPUT 1 and 2 jacks, noise may be input to the TRITON STUDIO via the AD converter even if no audio input is actually present, and depending on the settings, may be output from AUDIO OUTPUT L/R, 1, 2, 3, or 4. If you will not be using an external audio source, but are using only the internal sounds of a program, combination, or song, set "BUS (IFX/Indiv.) Select" to Off, or set "Level" to 0.

Similarly, if you will not be using the S/P DIF IN connector or mLAN connector, set these inputs to "BUS (IFX/Indiv.) Select" Off, or set their "Level" to 0.

If no audio cables are connected to the rear panel AUDIO INPUT 1 and 2 jacks, the data that is input to the TRITON STUDIO from the AD converter will be set to zero, and no noise will be output.

About dynamic modulation (Dmod)

Dynamic modulation (Dmod) is a function that lets you use MIDI messages or the TRITON STUDIO's controllers to control specific effect parameters in realtime. BPM/MIDI Sync is another function that controls effect parameters, and is used to synchronize the LFO speed of modulation-type effects or the delay time etc. of delay-type effects to the tempo of the arpeggiator or an external sequencer.

For details on each of these functions, refer to PG p.246, 248.

Setting example:

We will show how you can use dynamic modulation to control an effect parameter in realtime.

- ① As described in the procedure for "Effect settings for a program" (p.140), set "IFX1" to 049: L/C/R BPM Delay. Verify that a delay sound is being output.
- ② Access the Program P8: Edit-Insert Effect, IFX1 page.

Using Dmod to change the delay level by moving the joystick away from yourself

- ③ Set "Input Level Dmod" to +100.
- ④ Set "Src" to JS+Y: CC#01. The delay sound will disappear.

The input level to the effect can be controlled by the joystick. As you move the joystick away from yourself, the delay sound will gradually increase.

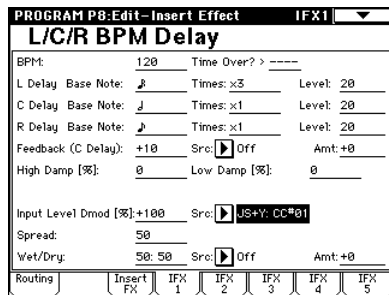

Using Dmod to modify the feedback level from [SW1] key

- ⑤ In P1: Edit-Basic, select the Controller Setup page, and set the function of "SW1" to SW1 Mod.: CC#80 (Toggle).
- ⑥ Return to P8. Set "Feedback Src" to SW 1: CC#80.
- ⑦ Set "Amt" to +30.

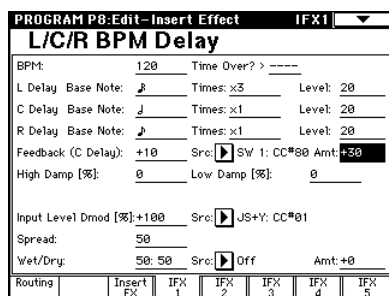

When you (move the joystick away from yourself and) press the [SW1] key, the feedback level will increase, and the delay sound will continue for a longer time. The "Amt" setting specifies the feedback level that will be in effect when the [SW1] key is pressed. If "Amt" is set to -10, pressing the SW1 key will reduce the feedback level to 0.

Using the BPM/MIDI Sync. function to synchronize the delay time to arpeggiator tempo changes.

- ⑧ Set "BPM" to MIDI.
- ⑨ For L, C, and R, set "Delay Base Note" and "Times" as desired.

For this example, set "Delay Base Note" to ♩ and "Times" to x1 so that the effect will be easily understandable. The delay time will repeat at an interval of 8th note.

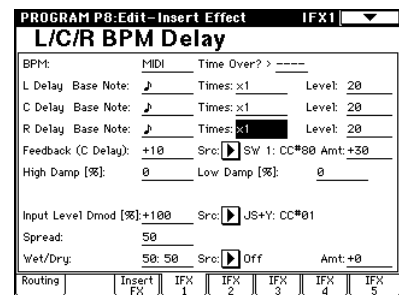

- ⑩ Rotate the [TEMPO] knob, and the delay time will change.

When you (push the joystick away from yourself and) press the [SW] key, the feedback level will rise, and the delays will become longer.

- ⑪ When you turn on the ARPEGGIATOR [ON/OFF] switch, the arpeggiator will begin playing.

Select any desired arpeggio pattern. When you rotate the [TEMPO] knob, the delay time will change in synchronization with the changing tempo of the arpeggio.

- ▲ If you rotate the [TEMPO] knob to change the tempo while the delay is sounding, noise may occur in the delay sound. This is because the delay sound becomes discontinuous, and is not a malfunction.

- MIDI For some effects, you can synchronize the LFO frequency to the tempo. Set the effect parameters "BPM/MIDI Sync" to On, and "BPM" to MIDI. For details refer to PG p.248.

Other functions

Setting the function of [SW1] and [SW2]

You can specify the function of the [SW1] and [SW2] keys (☞PG p.249).

The function of the [SW1] and [SW2] keys can be specified independently for each program, each combination, and each song. These functions can also be set independently for the entire mode in Sampling mode and Song Play mode.

You can specify the function that will be performed by the [SW1] and [SW2] keys, and can also select between **Toggle** (when the function will be switched on/off each time the [SW1] or [SW2] key is pressed) and **Momentary** (when the function will be on only while you continue holding the [SW1] or [SW2] key).

These settings are made by *Panel Switch Assign* in the following pages.

Program	P1: Edit-Basic, Controller Setup
Combination	P4: Edit-Zonr/Ctrl, Control
Song	P4: Zonr/Ctrl, Controller Setup
Sampling mode	P4: Controller Setup
Song Play mode	P2: Controller Setup

An example of settings in a program

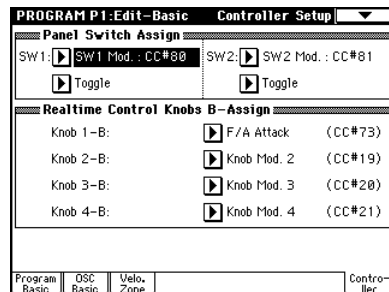

note When you write a program or combination, the on/off status of the [SW1] and [SW2] keys is memorized.

note You can use these keys as alternate modulation or effect dynamic modulation sources, and control program parameters or effect parameters. In this case, you will normally select SW1 Mod.:CC#80 and SW2 Mod.:CC#81.

For an example in which the [SW1] key is specified as an effect dynamic modulation source for a program and used to control an effect, refer to p.144.

note If you wish to keep these settings after the power is turned off, you must save them (☞p.56). However, the settings of Sampling mode cannot be saved.

Setting the B-mode functions of REALTIME CONTROLS [1]–[4]

You can specify the B-mode functions of REALTIME CONTROLS knobs [1]–[4] (☞PG p.250).

The B-mode functions can be specified independently for each program, each combination, and each song. These functions can also be set independently for the entire mode in Sampling mode and Song Play mode.

These settings are made in *Realtime Control Knobs B-Assign* of the respective page. (☞"Specifying the function of [SW1] and [SW2]")

note You can use these knobs as sources for alternate modulation or effect dynamic modulation, and control program parameters or effect parameters. In this case, you will normally select Knob Mod.1:CC#17, Knob Mod.2:CC#19, Knob Mod.3:CC#20, and Knob Mod.4:CC#21.

Here we will give an example of how knob [1] can be used to control the filter and amp EG attack of a program.

- ① Press the [PROG] key to enter Program mode.
- ② After pressing the [MENU] key, and press the P1: Edit-Basic.
- ③ Press the Controller tab.
- ④ Press the *Realtime Control Knob B-Assign* "Knob 1-B" popup button, and select F/A Attack.
- ⑤ Press the [REALTIME CONTROLS] key to select B-mode, and rotate knob [1]. The EG attack of the filter and amp will change.

note If you wish to keep these settings after the power is turned off, you must save them (☞p.56). However, the settings of Sampling mode cannot be saved.

Adjusting the contrast (brightness) of the LCD screen

Use the rear panel contrast knob to make adjustments.

Sounding a beep when the LCD screen is pressed

If the Global P0: Basic Setup, System Preference page “Beep Enable” check box is turned on, a beep will sound when you press an object in the LCD screen. Uncheck this if you do not want a beep to be sounded.

Using the TRITON STUDIO as a data filer

MIDI exclusive data transmitted from an external device can be received by the TRITON STUDIO and saved on a floppy disk, or other media (the Data Filer function). This is done using the Disk mode Save page “Save Exclusive” page menu command (PG p.168).

Setting the calendar function

Here’s how to set the date and time for the TRITON Studio’s internal calendar. The date and time are recorded when you save data. Use the page menu command “Set Date/Time” (Disk, Utility page) to make these settings.

note You will need make these settings after you purchase the TRITON Studio, and after you replace the calendar backup battery.

- 1 Press the [DISK] key to enter Disk mode.
- 2 Press the Utility tab.
- 3 Select the page menu command “Set Date/Time.”

The following dialog box will appear.

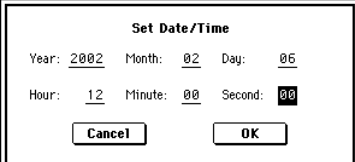

Set Date/Time					
Year:	2002	Month:	02	Day:	06
Hour:	12	Minute:	00	Second:	00
Cancel			OK		

- 4 Use the VALUE controllers to set “Year,” “Month,” “Day,” “Hour,” “Minute,” and “Second” to the correct year, month, day, hour, minute, and second.
- 5 Press the OK button.

 If the calendar backup battery runs low, a message of “Battery voltage for calendar IC” will appear in the LCD screen. If the calendar backup battery runs down completely, the calendar will be initialized, and the date and time will not be recorded correctly. You can replace the calendar backup battery by yourself. Refer to PG p.286 for details.

Shortcuts

[MENU] key + numeric keys [0]–[9]

- Accesses the pages within a mode

[ENTER] key + numeric keys [0]–[9]

- Accesses the page menu commands in each page (up to ten items)

[ENTER] key + keyboard

- Inputs note number values or velocity values
- Selects “KEY” in Global P5: Drum Kit, Sequencer P6: Pattern/RPPR, RPPR Setup page
- Selects base key and index in Sampling mode

[ENTER] key + [LOCATE] key

- In Sequencer mode and Song Play mode, sets the current location as the “Location” (equivalent to the “Set Location” page menu command)

Appendices

Troubleshooting

If you experience problems, refer to the relevant item and take the appropriate measures.

Power supply

Power does not turn on

- Is the power cable connected to an outlet? [p.11](#)
- Is the [POWER] switch turned on?
→ Turn on the rear panel [POWER] switch. [p.19](#)

LCD screen

The power is turned on, but nothing is shown in the LCD screen.

The TRITON STUDIO functions normally when you play the keyboard or perform other operations.

- Use the rear panel [Contrast adjustment] knob to adjust the contrast of the LCD screen. [p.7](#)

The power is turned on, but the LCD screen does not display normally, or an error message is displayed. There is no sound when you play the keyboard, and the TRITON STUDIO does not function normally.

- This type of problem may occur if a data writing operation to internal memory was not completed correctly, for example if the power of the TRITON STUDIO was turned off while a program or other data was being written. If this occurs, use the following procedure to initialize the TRITON STUDIO's internal memory.
 - ① Turn off the power.
 - ② Hold down the [MENU] key and the [9] key, and turn on the power.
The TRITON STUDIO will be initialized, and data will be written into internal memory. While the data is being written, the LCD screen will indicate "Now writing into internal memory."
After initialization, you will need to load the pre-loaded data. Load the data from the included floppy disk or the internal hard drive. [p.20, 63](#)

Can't operate the LCD screen correctly

- In Global P0: Basic Setup, execute the "Touch Panel Calibration" page menu command to adjust the sensitivity of the touch panel. [PG p.137](#)
- If it is not possible to select this command from the page menu, enter Global mode P0 (press the [MENU] key, and then press the [0] or [EXIT] key

to access this), and then hold down the [ENTER] key and press numeric key [2] to display the dialog box.

Can't switch modes or pages

- Are you recording or playing a song?
- Are you sampling?
- Are you playing a CD?
- Are you playing a WAVE file?

In Combination, Sequencer, or Song Play modes, can't edit the value of Timbre/Track parameters such as "MIDI Channel" or "Status"

- Some parameters cannot be edited during a "note-on" condition; i.e., while a note is held down on the keyboard, or while the damper pedal is held down.
→ Are you using a damper pedal with a polarity that does not match the "Damper Polarity" setting (Global P2: Controller)?
→ In some cases, this problem can be solved by executing the page menu command "Half Damper Calibration" (Global P0: Basic Setup).

No beep is sounded when you touch the LCD screen

- Check the "Beep Enable" check box (Global P0: Basic Setup, System Preference). [p.146](#)

Audio input and output

No sound

- Are connections made correctly to your amp, mixer, or headphones? [p.11](#)
- Is the connected amp or mixer powered-on, and is its volume raised?
- Is Local Control turned on?
→ In Global P1: MIDI, check the "Local Control On" check box. [PG p.142](#)
- Is the [VOLUME] slider raised? [p.3](#)
- If there is no sound from the OUTPUT (INDIVIDUAL) 1-4 jacks, make sure that "BUS Select" or "Bus Select" following the insert effect is set to 1, 2, 3, 4, 1/2, or 3/4. [p.140](#)
- If specific tracks in Sequencer mode or Song Play mode do not sound, Make sure that the PLAY/MUTE/REC button or PLAY/MUTE button is set to PLAY. [p.83, 123](#)
- Make sure that the "Status" is INT or BTH. [p.35, 82](#)

- Are the *Key Zone* and *Velocity Zone* set so that sound will be produced when you play? [PG p.11, 42, 66](#)

Notes do not stop

- In Program P1: Edit Basic, select the Program Basic page, make sure that the “Hold” check box is unchecked. [PG p.7](#)
- In Global P2: Controller, make sure that “Damper Polarity” or “Foot Switch Polarity” is set correctly. [PG p.146](#)

Can't input sound

- Are the appropriate sources connected to the AUDIO INPUT 1, 2 jacks, the S/P DIF IN jack, or the mLAN connector (if the EXB-mLAN option is installed)? [p.102](#)
- If there is no sound in Sampling mode, check that “Input,” “Level,” and “BUS (IFX/Indiv.) Select” are set correctly in the Sampling P0: Recording, Input/Setup page. [p.102](#)
- If there is no sound in Program, Combination, Sequencer, Song Play, and Disk modes, check that “Input,” “Level,” and “BUS (IFX/Indiv.) Select” are set correctly in Global P0: Basic Setup, Input/Sampling page; or in the P0: Sampling pages of Program, Combination, or Sequencer modes; or in the Disk mode Play Audio CD page. [p.102](#)
- If you are inputting sound to the AUDIO INPUT 1 and 2 jacks, make sure that the AUDIO INPUT [LEVEL] knob is raised. [p.103](#)
- If you are inputting sound to the AUDIO INPUT 1 and 2 jacks, is the [MIC/LINE] switch set appropriately? [p.102](#)
- Is an unsupported format being input from the S/P DIF IN jack?
→ Please connect an instrument or digital audio device that is compatible with CP-1201 or S/P DIF.
- Is the correct sampling frequency being input from the S/P DIF IN jack?
→ Sampling frequencies of 48 kHz and 96 kHz can be input. If you input an unsupported sampling frequency, noise will occur or a message of “S/P DIF Clock Error!” will be displayed. Set “S/P DIF Sample Rate” to match the sampling frequency that is being input (either 48 kHz or 96 kHz). The default setting for “S/P DIF Sample Rate” is 96 kHz (Normal). [PG p.138](#)

- ⚠ If “System Clock” is set to S/P DIF and “S/P DIF Sample Rate” is set to 48 kHz, and you want to change the sampling frequency that is being input to the S/P DIF IN jack from 96 kHz to 48 kHz or from 48 kHz to 96 kHz, you must make sure that the TRITON STUDIO is not accessing data when you make the change. Also, do not touch the TRITON STUDIO at this time. In particular, you must not change the sampling frequency being input to the S/P DIF IN jack when data access is occurring (e.g., load/save, read/write, or sampling operations involving the internal hard disk, floppy disk, CD-R/RW, external SCSI media, sample memory, or internal memory).

- Digital audio input is sometimes not heard for two or three seconds.
When you change the sampling frequency in “S/P DIF Sample Rate” (e.g., from 48 kHz to 96 kHz), two or three seconds will be required in order to lock to the new sampling frequency. Please wait until the sound is heard.
- If audio cannot be input from the mLAN connector (if the EXB-mLAN is installed), have the mLAN plug settings been made correctly? [PG p.139, 141](#)
- Is the correct sampling frequency being input from the mLAN connector (if the EXB-mLAN is installed)? [PG p.139, 141](#)
→ A sampling frequency of 48 kHz can be input.

Can't output sound from an audio CD

- Make sure that you have selected the Disk mode Play Audio CD page or Sampling mode.
- Make sure that the audio outputs of your external SCSI CD-R/RW drive are connected to the AUDIO INPUT jacks. [p.102](#)
- Is the CD output being correctly input?
→ If you want to listen to the audio CD playback in the Disk mode Play Audio CD page, set “Input (COMBI, PROG, SEQ, S.PLAY, DISK)” to Analog, and make the appropriate settings for “Level” and “BUS (IFX/Indiv.) Select.” If you want to listen to the audio CD playback in Sampling mode, make these settings in “Input (SAMPLING).” [p.102](#)
- Is the “Volume” slider raised? (Disk mode Play Audio CD page, Sampling P5: Audio CD, Ripping page) [p.120, 174](#)
- Has the CD been finalized?
→ A CD-R/RW disc that you wrote using the Disk mode Make Audio CD page cannot be played in the Disk mode Play Audio CD page or in Sampling mode unless you have finalized the disc. Execute the page menu command “Finalize Audio CD” to finalize the disc. [PG p.174](#)

Excessive noise or distortion in the audio input or in the sampled sound

- If you are inputting to the AUDIO INPUT 1 and 2 jacks, are the AUDIO INPUT [LEVEL] knob and “Recording Level” setting appropriate?
→ If “Recording Level” indicates “ADC OVER-LOAD!!,” adjust the [LEVEL] knob. If “CLIP!!” is displayed, adjust the “Recording Level” slider. Adjusting the “Recording Level” will not affect the level of the output sound, but will affect the level that is sampled. While watching the level meter, adjust “Recording Level” as high as possible without allowing “CLIP!!” to appear. [p.116](#)
- If you are inputting to the S/P DIF IN jack or mLAN connector (if the EXB-mLAN option is installed), are the level of the output device and the “Recording Level” set appropriately?
→ If “CLIP!!” appears, adjust the “Recording Level” slider.
- Is the system clock set correctly?
→ If cyclic click noise is occurring, check that you have selected the “System Clock” that is being input. [PG p.138](#)

Noise or oscillation is heard

- When using an effect on the external audio source being input from AUDIO INPUT 1 and 2, oscillation may occur depending on the type of effect or on the parameter settings. Please adjust the input level, output level, and effect parameters. You need to be particularly careful when using a high-gain effect.
- After a sample edit has been executed, or after a stereo sample has been recorded, a small noise may be heard. This has no effect on the audio data that was edited or sampled.
- When using the BPM/MIDI Sync function to control the delay time of an effect, noise may occur in the delay sound. This noise is due to discontinuities in the delay sound, and is not a malfunction.
- Some effects such as 015: St.Analog Record generate noise intentionally. It is also possible to create oscillation using a 24 dB/oct LPF filter with resonance. These are not malfunctions.

Program, Combination**Settings for oscillator 2 are not displayed**

- Make sure that the "Oscillator Mode" (Program P1: Program Basic) parameter is set to Double. [PG p.7](#)

A combination does not play correctly after you load data

- In the dialog box when you saved the data, did you check the items that you wanted to save? [PG p.166](#)
- Are the bank/numbers of the programs used by the combination the same as when the combination was created?

Song**A song does not play correctly after you load data**

- In the dialog box when you saved the data, did you check the items that you wanted to save? [PG p.166](#)
- Are the programs used by the song the same as when the song was created?
→ When saving the song, it is best to use "Save All" or "Save PCG & SEQ" so that the programs are saved together with the song. Then when loading, load both the .PCG and the .SEQ data. [PG p.166, 157](#)
- Have you loaded the multisamples and samples used by the program?

Playback does not start when you press the SEQUENCER [START/STOP] key in Sequencer mode

- Is the "MIDI Clock" (Global P1: MIDI) set to Internal? [PG p.143](#)

Can't record in Sequencer mode

- Is the Memory Protect "Song" check box (Global P0) unchecked? [PG p.139](#)
- Is the "MIDI Clock" (Global P1: MIDI) set to Internal? [PG p.143](#)

The arpeggiator settings that were copied from a combination using "Copy From Combi" cannot be recorded in the same way as when they were played

- Have you checked "Multi REC"? (Sequencer P0: Play/REC, Preference) [p.85](#)
- Depending on the settings of the combination, it may be necessary to adjust settings such as "Track Select," "MIDI Channel," "Status," and "Arpeggiator Assign." [p.96](#)
→ In the Copy from Combi dialog box, check the "Auto adjust Arp setting for Multi REC" option before you execute the copy. This will cause the settings to be adjusted automatically. [p.95](#)
→ The settings that are made automatically by "Auto adjust Arp setting for Multi REC" will be executed according to the ARPEGGIATOR [ON/OFF] key setting of the combination. If you want to turn on the arpeggiator in Sequencer mode and record the performance of a combination, make sure that the ARPEGGIATOR [ON/OFF] key is turned on for the combination when you write it in Combination mode. Then execute the "Copy From Combi." [p.95](#)

RPPR does not start

- Is the Sequencer P0: Play/REC "RPPR" setting checked? [p.33, 93](#)
- Are "Assign," "Pattern Select," and "Track" set correctly? [p.92, PG p.79](#)
- If the "MIDI Clock" (Global P1: MIDI) parameter set to Internal? [PG p.143](#)

In Song Play mode, a GM/GS/XG-compatible SMF is not played correctly

- Execute "GM Initialize" to initialize the settings. [PG p.124](#)
- Is "Bank Map" set to GM(2)? [PG p.137](#)
- Is "Status" set to INT? [PG p.126](#)

Sampling**Can't sample**

- Is sample memory (RAM) installed? [p.19](#)
- If you are sampling to external SCSI storage media, have you selected a hard disk? [PG p.5, 90](#)
- Are the audio input settings correct?
→ Refer to "Audio input and output - Can't input sound" [p.148](#)
- Is there free space in memory? [PG p.99, 175](#)
→ If you are sampling to sample memory (RAM), select a different memory bank. [PG p.6, 37, 57, 90](#)

- If you are sampling to hard disk, select a different hard disk. [PG p.7, 37, 57, 96](#)
- Delete unneeded samples. [PG p.92](#)
- Save samples you want to keep, and then delete them. [PG p.167, 92](#)
- Is the “Trigger” setting correct? [PG p.4, 37, 56, 97](#)
- In Sampling mode if you are resampling with “Resample” set to Auto, has the sample to be resampled been assigned to the keyboard, and selected for “Key”? [p.107, PG p.98](#)
- Is the “Source BUS” setting correct?
 - If you want to listen to the performance of the internal tone generator while sampling only the external input sound (i.e., when using the In-Track Sampling function), you will normally set this to Indiv.1/2. For other types of sampling or resampling, set this to L/R. [p.104, PG p.4, 37, 56, 97](#)
- If a message of “Buffer underrun error occurred” is displayed frequently when you are sampling to hard disk, execute the page menu command “Check Medium” (Disk, Utility page) to find and correct any errors on the selected MS-DOS format media. [PG p.171](#)

A stereo sample can't be played in stereo

- Is the multisample stereo?
 - Execute the page menu command “MS Mono To Stereo” to convert the multisample to stereo. [PG p.94](#)
- Is the sample name assigned correctly? [PG p.90](#)

Volume of a recorded sample is too low/too high

- A sample that you resampled with “Recording Level” set at approximately -12.0 (dB) plays back at a lower volume than the volume at which you resampled it.
 - Did you turn on the “Auto +12 dB On” setting when you resampled? [p.105](#)
 - If you resampled with “Auto +12 dB On” turned off, turn on “+12 dB” (Sampling mode Loop Edit page) for that sample.
- The playback volume of a sample is different than the volume at which it was resampled or sampled.
 - If the sample playback is louder, did you set “Recording Level” above +0.0? If it is lower, did you set “Recording Level” below +0.0? The “Recording Level” setting affects the level of the sample data that is recorded, but it is not possible to monitor that level.
 - If the sample playback is louder, is “Auto +12 dB On” turned on? If the playback is softer, is this setting turned off?
 - If you resampled the playback of a song or your playback performance using a program, combination, or sample, or combined your performance with an external audio source and sampled the result, did you set “Recording Level” to approximately -12.0 dB and turn on the “Auto +12 dB On” setting? [p.105](#)
 - If you sampled only an external audio source, did you set “Recording Level” to approximately +0.0, and turn off “Auto +12 dB On”? [p.105](#)

Song or CD playback stops temporarily when you sample

- Is “Auto Optimize RAM” checked?
 - If this is checked, RAM will be optimized automatically when sampling ends, meaning that the sound will stop when sampling ends. If a song is being played in Sequencer mode or if a CD is being played back, the playback will stop.

There is a time lag after you press the SAMPLING [REC] key until you enter sampling-standby mode

- The length of time until you enter sampling-standby mode will depend on the state of the free space on the hard disk (i.e., whether the free space is continuous or fragmented).
 - When sampling to the hard disk, pressing the SAMPLING [REC] key will cause the amount of space specified by “Sample Time” to be allocated within the hard disk.
 - You should set “Sample Time” slightly longer than the length that you will actually sample, and avoid specifying an excessively long sample time.

Drum kits

The pitch of a drum sample does not change

- You have left the “Assign” check box unchecked, and want to play the drum sample at the adjacent right a semitone lower, but the pitch does not change.
 - If you have selected a drum program in Program mode, and then want to edit the drum kit in Global mode, go to the Program P2: Edit-Pitch, OSC1 Pitch Mod. page and set “Pitch Slope” to +1.0 before you enter Global mode.

Arpeggiator

Arpeggiator does not start

- Is the ARPEGGIATOR [ON/OFF] key turned on (lit)?
- If the arpeggiator does not start for a combination or song, make sure that “Arpeggiator Run” is checked, and that an arpeggiator is selected for “Assign.” [p.28, PG p.44, 82, 130](#)
- Is the “MIDI Clock” (Global P1: MIDI) parameter set to Internal? [PG p.143](#)
- If the ARPEGGIATOR [ON/OFF] key does not respond in Global P6: User Arpeggio, you may have moved here from Sampling mode or Disk mode.

Effects

Effects are not applied

- Have you selected effect program 000?

→ Select an effect other than 000: No Effect for “IFX1–5” or “MFX 1, 2.”

- Are the “IFX 1–5 Off,” “MFX1 Off,” or “MFX2 Off” (Global P0: Basic page) settings checked? [PG p.140](#)
- If you are in Combination, Sequencer, and Song Play, and master effects are not applied when you raise the “Send1” or “Send2” of the timbre/track, does “Return 1” or “Return 2” from the master effect need to be raised? [PG p.141](#)
Alternatively, has “Send 1” or “Send 2” for each oscillator of the program used by the timbre/track been lowered? [PG p.140](#)

note The actual send level is determined by multiplying the send setting of each oscillator in the program with the send setting of the timbre/track.

- Have you routed the output to an insert effect? [PG p.140, 141](#)

MIDI

The TRITON STUDIO does not respond to incoming MIDI data

- Are all MIDI cables connected correctly? [PG p.258](#)
- Is the MIDI data being received on the channel on which it is being transmitted? [PG p.259](#)

The TRITON STUDIO does not respond correctly to incoming MIDI data

- Are the Global P1: MIDI settings “Enable Program Change,” “Enable Bank Change,” “Enable Control Change,” and “Enable AfterTouch” each checked? [PG p.144](#)
- If you wish to receive MIDI exclusive messages, is the “Enable Exclusive” (Global P1: MIDI) item checked? [PG p.144](#)
- Does the TRITON STUDIO support the types of messages that are being sent to it? [PG p.259](#)

Media

Floppy disk

Can't format a floppy disk

- Are you using a 3.5 inch 2HD or 2DD floppy disk?
- Is the floppy disk inserted correctly?
- Cover the write protect hole of the floppy disk, so that it is in the “write permit” position.
→ Correctly insert a 3.5 inch 2HD or 2DD floppy disk (with its write protect hole covered) into the disk drive, and format it once again.

Can't save/load data to/from a floppy disk

- Is the floppy disk inserted correctly?
- Is the floppy disk formatted?

- Is the write protect hole of the floppy disk covered, so that it is in the “write permit” position?
→ Correctly insert a 3.5 inch 2HD or 2DD floppy disk (with its write protect hole covered) into the disk drive, and perform the save or load operation once again.

Internal hard drive, external devices

SCSI-connected external drive is not recognized

- Has the drive been formatted? [PG p.170](#)
- Is the external device connected correctly? [PG p.298](#)
- Is the terminator of the external device connected correctly? [PG p.298](#)
- The SCSI device ID settings of two or more drives may be conflicting.
→ For details on setting the SCSI device ID, refer to the owner's manual for your drive.
- You may have turned on the power of the SCSI device after powering-on the TRITON STUDIO.
→ Turn off the power of the SCSI device and of the TRITON STUDIO. Then turn on the power of the SCSI device, and wait at least ten seconds before powering-on the TRITON STUDIO.
- Execute the page menu command “Scan SCSI device” (Disk, Media Information) to re-mount the SCSI device.

The TRITON STUDIO does not recognize when MO disk has been exchanged, and does not correctly display the media information after the exchange.

- If you are able to switch the mode setting of your MO drive between PC/AT and Mac settings, please use PC/AT mode. For details on changing the mode of your drive, refer to the owner's manual for your MO drive.
- If your MO drive does not have a mode setting, or if the media exchange is not recognized even after you switch the mode, use the drive select button to select a different drive, and then re-select the MO drive.

“Error in writing to medium” occurs frequently when saving data to the internal hard drive or external device

- Execute the page menu command “Check Medium” (Disk, Utility page) to detect and correct errors on the selected MS-DOS format media. [PG p.171](#)

CD-R/RW

CD-R/RW drive is not recognized

- If you are using the CDRW-1 option, was it installed correctly?
→ Turn on the power of the TRITON STUDIO once again, and verify that the CDRW-1 is displayed in the startup screen. If it is not displayed, turn off the power, and re-install the drive correctly. [PG p.19](#)

Can't write

- Was the drive subjected to physical shock or vibration while data is being written?
- If you are unable to save data such as PCG or SNG files, has the disc been formatted?
If you are writing audio tracks to create an audio CD, it is not necessary to format the disc.
- Are you using the recommended media for your drive?
- If you are writing from an external SCSI drive to CD-R/RW, it is possible that the transfer speed is insufficient.
→ Writing may be successful if you lower the writing speed. PG p.173
→ Writing may be successful if you first copy the data from the external SCSI drive to the internal hard disk, and then execute the writing operation from the internal hard disk.
- In some cases, a certain length of time may be required before the data begins to be saved. When first saving data on high-capacity media (e.g., the first time after powering-on the TRITON STUDIO that you save in Disk mode or execute sampling to hard disk in Sampling mode), some time will be required to allocate free area.
- Are you using blank media?
→ If using CD-R, please use new media. If using CD-RW, use the page menu command "Erase CD-RW" (Disk, Make Audio CD) to erase the contents of the media before you execute Save.

A CD-R/RW saved on the TRITON STUDIO is not recognized by an external device.

- A CD-R/RW saved or copied on the TRITON STUDIO using packet writing is not recognized on a computer.
→ If you install a UDF version 1.5 compatible UDF reader or packet writing software on your computer, it will be possible to recognize the disc. PG p.299
→ In the case of a CD-R, it may be possible to make the disc be recognized by executing the page menu command "Convert to ISO9660 Format" (Disk, Utility page) to convert the disc to ISO9660 format. However depending on the state in which the disc was saved, it may be converted into ISO9660 level 3 format, and may still not be recognized. In this case if you install ISO9660 level 3 compatible reader software or packet writing software on your computer, it will be possible to recognize the disc. PG p.299
- A CD-R/RW that was saved or copied on the TRITON STUDIO using packet writing is not recognized by the TRITON/TRITON pro/TRITON proX/TRITON-Rack.
→ These models do not support UDF version 1.5, and therefore will not recognize such a disc.
→ In the case of a CD-R, it may be possible to make the disc be recognized by executing the page menu command "Convert to ISO9660 Format" (Disk, Utility page) to convert the disc to ISO9660 format. However depending on the state in which the disc was saved, it may be converted into ISO9660 level 3 format, and may still not be recognized. PG p.299

Can't write audio tracks

- Additional writing is not possible on a CD-R/RW disc that has been finalized.

Can't play back the disc on an audio CD player

- Did you finalize the disc?
→ If you want to finalize the disc after writing additional data, check the "Execute finalize too" check box when executing the page menu command "Write to CD" (Disk, Make Audio CD), so that the disc will be finalized. PG p.119, PG p.173
→ If you only want to finalize the disc, select the page menu command "Finalize Audio CD" (Disk, Make Audio CD), and press the OK button to finalize the disc. PG p.173
- Are you using CD-R media?
→ Since some CD players are unable to play CD-RW media, we recommend that you use CD-R media.
- Have you tried using a different type of media?
→ Some CD-R/RW media cannot be played by some CD players. You may be able to play back successfully by using a different type (brand) of CD-R/RW media.

WAVE files

Playback level of the WAVE file is too high

- Set "WAVE File Play Level" to Normal. You should usually set "WAVE file Play Level" at Normal, and set it to High (+12 dB) only if the S/P DIF output is too low. With the High (+12 dB) setting, the output from AUDIO OUTPUT L (MONO), R, and HEADPHONES will be louder. PG p.138

WAVE file playback level is louder/softer than the RAM samples

- Adjust the "WAVE File Play Level." You should usually set "WAVE File Play Level" to Normal, and use the "High (+12 dB)" setting only if the WAVE file playback volume is lower than the playback of the RAM samples. You should also use the "High (+12 dB)" setting if the S/P DIF output is not loud enough.

Can't preview

- Is the WAVE file format supported?
→ Select a WAVE file of a supported format. PG p.156, 172, 283

Other

- Saved files or sampled WAVE files have an incorrect date/time.
→ Use the page menu command "Set Date/Time" (Disk, Utility page) to set the current date and time. PG p.146, PG p.170

Specifications and options

Specifications

System	HI (Hyper Integrated) synthesis system	
Modes	Combination, Program, Sequencer, Sampling, Song Play, Global, Disk	
Tone generator	HI (Hyper Integrated) synthesis system	
	Polyphony	60 voices (60 oscillators)/Maximum 120 voices (120 oscillators)* in single mode *: p.15 30 voices (60 oscillators)/Maximum 60 voices (120 oscillators)* in double mode *: p.15
	Filters	24 dB/oct LPF with resonance
		12 dB/oct LPF + HPF
	Alternate modulation function	
Waveform memory	48 Mbytes PCM ROM (429 multisamples, 417 drumsamples)	
	PCM ROM options allow expansion of up to 112 Mbytes (EXB-PCM series is supported)	
	16 Mbytes user sampling RAM (SIMM) (expandable to a maximum of 96 Mbytes)	
Sampling	48 kHz, 16 bit linear	
	Maximum sample data memory capacity 96 Mbytes (with SIMM expansion)	
	4,000 samples, 1,000 multisamples (128 indexes for each multisample)	
	Record/playback/rip CD-DA (audio CD)	
	Able to load AIFF, WAVE, AKAI (S1000/3000), Korg format sample data can be loaded	
	Sample data can be exported in AIFF or WAVE formats	
Effect section	5 insert effects (stereo in/out),	
	2 master effects (mono in/stereo out), 1 master EQ (3-band stereo), all usable simultaneously	
	102 effect types (available for insert effects or master effects)	
	Effect dynamic modulation function	
Combinations/ Programs	1,536 user memory combinations (512 presets)	
	1,536 user memory programs (128 more when EXB-MOSS is installed) (512 presets)	
	256 + 9 drum ROM programs (GM2 sound map compatible)	
Drum Kits	144 user drum kits (20 presets)	
	9 ROM GM drum kits (GM2 sound map compatible)	
Dual polyphonic arpeggiator	Use two arpeggiators simultaneously (Combination, Sequencer, Song Play modes)	
	5 preset arpeggio patterns	
	507 user arpeggio patterns (367 presets)	
Sequencer	16 timbres, 16 tracks + 1 master track	
	Maximum capacity: 200,000 notes	
	Resolution ↓/192	
	200 songs, 20 cue lists, 150 preset patterns, 100 user patterns (for each song)	
	16 preset/16 user template songs	
	Supports TRITON format and SMF (formats 0 and 1)	
	RPPR (Realtime Pattern Play/Recording) function (One set is available for each one song)	
Song play	16 timbres, 16 tracks	
	SMF (formats 0 and 1) supported	
Disk mode	Load, save, utility Audio CD writing/playback	
	Data filer function (save/load MIDI exclusive data)	
	CD-ROM/R/RW (read and write UDF format CD-R/RW, record and play CD-DA, load ISO9660 level 1 data) supported	
Keyboard	88 keys (RH2)*, 76 keys, 61 keys * The 88 keys model features an RH2 (Real Weighted Hammer Action 2) keyboard, which provides a differing key weight in each of four keyboard ranges, just as on a grand piano.	
Controllers	Joystick, ribbon controller, [SW1]/[SW2] keys, REALTIME CONTROLS knobs [1]–[4] and A/B mode key, [VALUE] slider, ARPEGGIATOR [TEMPO], [GATE], [VELOCITY] knobs and [ON/OFF] key	

User interface	TouchView graphical user interface (320 × 240 pixel LCD display)	
	[VOLUME] slider	
	Mode keys	[COMBI], [PROG], [SEQ], [SAMPLING], [S.PLAY], [GLOBAL], [DISK]
	Value controllers	[VALUE] slider, [VALUE] dial, [△] [▽] keys, numeric keys ([0]...[9], [-], [./10's HOLD], [ENTER])
	[MENU] key, [EXIT] key, [COMPARE] key	
	BANK keys	[INT-A], [INT-B], [INT-C], [INT-D], [INT-E], [INT-F], [INT-G], [EXB-A], [EXB-B], [EXB-C], [EXB-D], [EXB-E], [EXB-F], [EXB-G]
	SEQUENCER keys	[PAUSE], [REW], [FF], [LOCATE], [REC/WRITE], [START/STOP]
	SAMPLING keys	[REC], [START/STOP]
Audio outputs	AUDIO OUTPUT (MAIN) L/MONO, R AUDIO OUTPUT (INDIVIDUAL) 1, 2, 3, 4	Output impedance 1.1 [kΩ] (L/MONO is 550 [Ω] for mono) Maximum output level +13.5 [dBu] Load impedance 100 [kΩ] or greater
	AUDIO OUTPUT HEADPHONE	Output impedance 33 [Ω] Maximum output level 25 [mW] Load impedance 33 [Ω]
	S/P DIF	Connector: optical, Format: 24-bit S/P DIF (IEC60958, EIAJ CP-1201), Sample rate: 48 kHz, 96 kHz selectable
Audio inputs	AUDIO INPUT 1, 2 LEVEL [MIC/LINE] switch, [LEVEL] knob	Input impedance 10 [kΩ] Nominal level LINE: +4 [dBu] @ [LEVEL] knob= min. -30 [dBu] @ [LEVEL] knob= max. MIC: -17 [dBu] @ [LEVEL] knob= min. -52 [dBu] @ [LEVEL] knob= max. Maximum level LINE: +14 [dBu] @ [LEVEL] knob= min. -20 [dBu] @ [LEVEL] knob= max. MIC: -7 [dBu] @ [LEVEL] knob= min. -42 [dBu] @ [LEVEL] knob= max. Source impedance 600 [Ω]
	S/P DIF	Connector: optical, Format: 24-bit S/P DIF (IEC60958, EIAJ CP-1201), Sample rate: 48 kHz, 96 kHz selectable
Control inputs	DAMPER (half-damper supported), ASSIGNABLE SWITCH/PEDAL	
Internal hard drive	5 Gbyte	
Other	MIDI IN, OUT, THRU, SCSI connector (D-sub half-pitch 50 pin), LCD contrast knob, 3.5 inch floppy disk drive, AC power inlet, power switch, Calendar backup battery	
Support for options	EXB-PCM series PCM expansion board (16 Mbytes ROM) slots × 7	
	72 pin SIMM memory slots × 3 (for user sample memory)	
	CDRW-1, EXB-MOSS, EXB-DI, EXB-mLAN	
Dimensions (W × D × H)	88Keys: 1475 × 440 × 146 (mm) Inches: 58.07" × 17.32" × 5.75", 76Keys: 1311 × 382 × 129 (mm) Inches: 51.61" × 15.04" × 5.08", 61Keys: 1104 × 382 × 129 (mm) Inches: 43.46" × 15.04" × 5.08"	
Weight	88 Keys: 29.7 kg/65.48lbs., 76 Keys: 19.6 kg/43.21lbs., 61 Keys: 17.2 kg/37.92lbs.	
Power supply	AC Local Voltage	
Power consumption	38 W	
Included items	AC cable, Preloaded program disks TNSFD-00P, Installation plate for EXB-mLAN	

Options

Expansion boards	
EXB-MOSS (DSP Synthesizer Board)	
EXB-DI (Digital Interface Board)	
EXB-mLAN (mLAN Interface Board)	
EXB-PCM series	
EXB-PCM01: Piano/Classic Keyboards	
EXB-PCM02: Studio Essentials	
EXB-PCM03: Future Loop Construction	
EXB-PCM04: Dance Extreme	
EXB-PCM05: Vintage Archives	

EXB-PCM06/07: Orchestral Collection	
EXB-PCM08: Piano	
The multisamples of the EXB-PCM08 are built into the TRITON STUDIO.	
CD-R/RW drive	CDRW-1
Expression/volume pedal	XVP-10
Foot controller	EXP-2
Damper pedal	DS-1H
Pedal switch	PS-1
Other	MIDI cable

* Appearance and specifications of this product are subject to change without notice. (March/02)

TRITON STUDIO MIDI Implementation Chart

Function		Transmitted	Recognized	Remarks
Basic Channel	Default	1 - 16	1 - 16	Memorized
	Changed	1 - 16	1 - 16	
Mode	Memorized Messages Altered	x *****	3 x	
Note Number:	True Voice	0 - 127 *****	0 - 127 0 - 127	Sequencer and Arpeggiator data can transmit all note numbers 0-127
Velocity	Note On Note Off	9n, V=1 - 127 x	9n, V=1 - 127 x	
Aftertouch	Polyphonic (Key) Monophonic (Channel)			Polyphonic aftertouch transmitted only as sequence data *A *A
Pitch Bend				*C
Control Change	0, 32			Bank Select (MSB, LSB) *P
	1, 2, 16, 18			Joystick (+Y, -Y), Ribbon, Slider *C
	4, 5, 7, 8, 10			Pedal, Portamento Time, Volume, IFX pan, Pan *C
	11, 12, 13			Expression, Effect Control 1/2 *C
	64, 65, 66, 67			Damper, Portamento Sw., Sostenuto, Soft *C
	70 - 79			Sound (Realtime Controls 1-4A: 74, 71, 79, 72) *C
	80, 81, 82, 83			Switch 1, 2, Foot Switch, Controller *C
	93, 91, 92, 94, 95			Send 1, 2, Effect ON/OFF (IFXs, MFX1, MFX2) *C
	6, 38			Data Entry (MSB, LSB) *C
	96, 97	x		Data Increment, Decrement *C
98, 99			NRPN (LSB, MSB) *C, *2	
100, 101	x		RPN (LSB, MSB) *C, *3	
0 - 95			Realtime Controls knobs 1-4 B-assign *C	
0 - 101			Sequencer data (receive *C)	
120, 121	x		All Sound Off, Reset All Controllers *C	
Program Change	Variable Range	0 - 127 *****	0 - 127 0 - 127	*P
System Exclusive				*E*4
System Common	Song Position			When cue list is selected, corresponds to cue list *1
	Song Select Tune	0 - 127 x	0 - 127 x	When cue list is selected, corresponds to cue lists 0-19 *1
System Real Time	Clock Command			*1 *1
Aux Messages	Local On/Off	x		
	All Notes Off	x	123 - 127	
	Active Sense Reset	x x	x	
Notes *P, *A, *C, *E: Transmitted/received when Global P1: MIDI Filter (Program Change, After Touch, Control Change, Exclusive) is Enable, respectively. *1: When Global mode P1: MIDI Clock is Internal, transmitted but not received. The opposite for External MIDI or mLAN. *2: LSB,MSB=02,00: Arpeggiator ON/OFF, 0A,00: Arpeggiator Gate control, 0B,00: Arpeggiator Velocity control *3: LSB,MSB=00,00: Pitch bend range, 01,00: Fine tune, 02,00: Coarse tune *4: In addition to Korg exclusive messages, Inquiry, GM System On, Master Volume, Master Balance, Master Fine Tune, and Master Coarse Tune are supported.				

Mode 1: OMNI ON, POLY Mode 2: OMNI ON, MONO ○ : Yes
 Mode 3: OMNI OFF, POLY Mode 4: OMNI OFF, MONO × : No

Consult your local Korg distributor for more information on MIDI IMPLEMENTATION.

Index

Numerics

10's Hold **4, 23, 24**
24 dB/oct low pass filter with resonance **71**

A

After Touch **26, 27, 124**
Allocation **20, 42**
Alternate Modulation **74**
Amp **68, 73**
 Amp EG **72, 73**
 Amp Level **34, 73**
 Amp Mod. **73**
 Keyboard Track **73**
 LFO **73**
Amp EG **27, 34, 73**
Amplifier **34, 68, 72**
AMS (Alternate Modulation Source) **71, 72, 73, 74**
Append **20, 66**
Arpeggiator **2, 5, 29, 45, 46, 51, 74, 80, 87, 94, 123, 130, 132, 150**
ASSIGNABLE PEDAL **7, 11, 28, 125**
ASSIGNABLE SWITCH **7, 11, 28, 84, 91, 125**
Audio CD **5, 109, 118, 148, 152**
AUDIO INPUT **6, 11, 37, 42, 46, 48, 102, 109, 115, 139, 143, 148**
Audio input/output
 Analog **11, 42, 102, 108**
 Digital **7, 11, 102, 108**
Auto +12 dB On **105**
Auto punch-in **84**
Auto-pan **71, 73, 74**

B

Bank **4, 17, 22, 24, 64**
BANK key **4**
Base key **111, 146**
Bit resolution **100**
BPM **44, 78, 112, 144**
BUS Select **6, 47, 48, 109, 115, 129, 140, 141, 142**

C

Calendar function **146**
Cancel button **4, 9**
Category **8, 23, 24, 35, 69, 82, 128, 140**
CD-R/RW **6, 19, 59, 60, 108, 118, 151**

Check box **9**
Combination **1, 13, 16, 24, 31, 35, 56, 63, 75, 102, 132, 139, 141, 149**
Compare **17, 68, 76, 97**
 [COMPARE] key **17**
Connection **10**
Controller **25, 29, 53, 79, 87, 98**
Copy **14, 67, 88, 96, 131**
Copy the sounds of a combination to multiple tracks **95**
Create Control Data **86**
Cue List **21, 81, 90, 92**
Current page **8**
Cutoff frequency **26, 71**

D

DAMPER **7, 11, 28, 78**
Damper Pedal **28**
Data dump **55, 62**
Delete
 Specific data **85, 87**
Demo song **20**
Dialog **9**
DIGITAL OUT **7, 11**
Disk **14, 16, 60, 64, 102, 118**
Dmod **144**
Drum Kit **58, 69, 73, 128, 150**
Drum sample **128, 150**
Dual arpeggiator **137**
Dynamic modulation **144**

E

Edit Buffer **58**
Edit cell **8, 17**
Effect **1, 124, 139**
EG **27, 34, 71, 72, 73**
Event Edit **86**
EXB-DI **7, 11, 19**
EXB-mLAN **7, 11, 19, 102, 143**
EXB-MOSS **19, 22, 24, 67**
 Load **66**
EXB-PCM **15, 19, 69, 128**
 Load **65**
EXB-PCM/sample memory (RAM) slot cover **5**
Exclusive Group **129**
 [EXIT] key **4**
 .EXL file **55**
External sequencer **85, 138**

F

Filter **1, 26, 34, 68, 71**
 Filter EG **72**
 Filter LFO Mod. **72**
 Filter Mod. **72**
 Keyboard Track **72**
Floppy disk **6, 59, 62**
Foot Pedal **28, 125**
Foot pedal **11**
Foot Switch **28, 125**
 Cue List, Switch the Step **91**
 Manual punch-in **84**
 Program/Combination will change **125**
Foot switch **11**
Format **12, 59, 60**

G

Global **14, 16, 58, 124, 127, 134**
GM(2) **22, 121, 127**
GM/GS/XG **149**
Grid **110**

H

Headphone **6, 11**
HI (Hyper Integrated) synthesis system **1**

I

Index **38, 106, 111, 112**
(INDIVIDUAL) **1, 2, 3, 4, 6, 11, 48, 103, 104, 115, 129, 140, 147**
Insert Effect (IFX) **34, 39, 74, 79, 103, 107, 129, 139, 140, 141, 142**
Internal hard drive **iii, 20, 59, 63, 151**
In-Track Sampling **2, 115**

J

Joystick **3, 25, 53, 72**
 Lock function **26**
 Pitch bend **70**
Jukebox **122**
Jukebox list **122**

K

Key Zone **77**
Keyboard & Index **106, 110, 111**
Keyboard crossfade **76**
Keyboard input **18**
Keyboard Track **72, 73**

Keyboard, Arpeggiator **31, 131**
 .KMP **41, 55, 61, 63**
 .KSC **21, 42, 55, 61, 63**
 .KSF **41, 55, 61, 63**

L

L/MONO, R jacks **6, 11, 38, 140**
 Layer **76, 78**
 LCD screen **4, 8**
 Contrast **7, 145, 147**

Level
 Amp Level **34**
 AUDIO INPUT **6, 102**
 Drum Kit **128**
 Multisample **69**
 OSC Balance **34**
 Recording level **105**
 WAVE file **116, 152**

LFO **70, 72, 74, 144**

Load
 EXB-MOSS series **66**
 EXB-PCM series **65**
 Jukebox List **122**
 Restoring the factory settings **63**
 Template Son **49**
 Types of data **63**

LOCATE **5, 83, 146**

Lock function **26**

Loop
 Sample **38, 42, 43, 110**
 Track Play Loop, Sequencer **50**

Loop All Track **85**

Low Pass & High Pass **71**

Low pass filter **26, 71**

Low Pass Resonance **71**

LPF CUTOFF **26**

M

Manual punch-in **84**

Master Effect (MFX) **74, 79**

Master EQ (MEQ) **141, 142**

Media **55, 59, 60**

Memory protect **57**

[MENU] key **4, 16**

Metronome **48, 51, 84**

[MIC/LINE] switch **6, 37, 42, 46, 102**

.MID **55, 120**

MIDI **7, 12, 62, 85, 98, 120, 151**
 MIDI Channel **67, 77, 82**
 MIDI clock **138**
 MIDI filter **78**

Minus-one play **123**

mLAN **7**

Mode **3, 13, 16**

Monitor **6, 11, 48, 82, 107, 115, 150**

Monophonic **68, 77**

Multi (multitrack recording) **85**

Multisample **1, 38, 40, 41, 68, 101, 106, 112, 127**

Mute **82, 121**

N

Note Number **27**

O

OK button **9**

Open Sampling System **2**

Option **12, 154**

Oscillator **15, 68**

Oscillator Mode **15, 68, 69**

Overdub **84**

Overwrite **83**

P

Page **8, 16**

Page jump menu **9, 16**

Page menu button **9**

Page menu command **9**

Pan
 AUDIO INPUT **143**
 Combination **36, 76**
 Program **71, 73, 74, 140**
 Sampling **37**
 Sequencer **82**

Parameter **17**

Pattern
 Arpeggio pattern **30, 32**
 Pattern, Sequencer **81, 83, 86, 90, 92, 112**

.PCG **21, 55, 61, 63**

Performance Edit **34**

Pin **8**

Pitch **68, 70, 124**
 Combination **77**
 Controller **25, 70**
 Drum kit **128, 150**
 EG **70, 71**
 LFO **70, 71**
 Sampling **38, 112**

Place, Sequencer **83**

Polyphonic **68, 77**

Popup button **8, 18**

Popup menu **8, 18**

Portamento **70, 77, 78**

Power **6, 11, 19, 125**
 Recalling the last-selected mode **125**

Preload data **56**

PRELOAD.KSC **21**

PRELOAD.PCG **21, 63**

PRELOAD.SNG **21**

Program **1, 13, 22, 29, 34, 45, 46, 56, 67, 102, 130, 139, 140**
 Combination **35, 76**
 Sampling **41, 112**
 Sequencer **82**

Q

Quantize **51**

R

Radio button **9**

REALTIME CONTROLS **3, 26, 34, 145**

Realtime Quantize **51**

Realtime recording
 Pattern **86**
 Track **83**

[REC] key **5, 103, 104**

[REC/WRITE] key **5, 51, 57, 59, 84**

Recording Level **37, 43, 45, 47, 103, 148, 150**

Rename **40, 43, 53, 57**

Resampling **45, 48, 107, 116**

Resonance **26, 71, 72**

RESONANCE/HPF **26**

Restoring the factory settings **63**

Ribbon controller **3, 25**
 Lock function **26**
 Pitch bend **70**

Routing **129, 140, 141, 142, 143**

RPPR **33, 92, 113**
 Create **92**
 Play **33, 93**
 Realtime-recording **94**
 Shutdown Key, RPPR stop **33**

S

S/P DIF **7, 11, 102, 142, 143, 148**

Sample **37, 39, 40, 43, 45, 47, 78, 99, 101, 107, 108, 111**

Sample memory (RAM) **2, 5, 19, 104, 105**

Sampling **2, 5, 14, 16, 37, 39, 41, 46, 48, 100, 102, 106, 115, 139, 142**

Sampling frequency **100, 118, 148**

Save **55, 60, 61**
 Data Filer function **146**
 Jukebox list **122**
 Media **59**
 Sample data **41, 111**
 Song **54**
 Track list **119**

Scale **78, 126**

Scroll bar **8**

SCSI **7, 12, 41, 59, 105, 108, 151**

Send
 AUDIO INPUT 143
 Combination, Sequencer, Song Play 141
 Drum kit 129
 Program 140
 Sequencer 5, 14, 16, 21, 33, 49, 80, 81, 99, 102, 112, 115, 138, 139
 Shortcut 146
 SIMM 5, 19
 .SNG file 55, 61
 Solo 82, 121
 Song 21, 33, 49, 80, 81
 Convert a cue list 92
 Copy 88
 Create a WAVE file 116
 Edit 88
 In-Track Sampling 115
 Naming 53, 88
 Save 54
 Setting the number of measures 88
 Song Play 14, 16, 102, 120, 138, 139, 149
 Song Play, Sequencer 141
 Sounding a beep 146
 Specifications 153
 Split 76, 77
 Standard MIDI File (SMF) 80, 97, 120
 Status 77, 98, 120
 Step
 Cue List 21, 90
 User arpeggio pattern 134
 Step recording 52, 86
 Step, Arpeggiator 135
 Stereo 111
 [SW1], [SW2] 3, 25, 27, 144, 145
 Synchronization 138
 Song Play 120
 Synchronize 144

T

Tab 9, 16
 Template song 49, 120
 Tempo 5, 29, 50, 74, 82, 91, 110, 112, 130, 132, 144
 Text edit button 9, 40, 56, 57
 Timbre 35, 76
 Time signature 80, 82, 86
 TNSFD-00P 65
 Toggle button 9
 Tone 26, 27, 68, 71, 124
 User arpeggio pattern 135
 Tone Generator 15
 Tone, Arpeggiator 135
 TouchView 2

Track 83
 Musical data 81, 113
 Setup parameters 81
 Track edit 90
 Track Play Loop 50
 Track list 119
 Transpose 77, 124
 Tremolo 71, 73, 74
 Tune 34
 Tuning 124

U

Use DKit Setting 73
 Use Zero 111
 User arpeggio pattern 130
 User pattern 81, 86
 User Scale 126
 User template song 55

V

VALUE controller 4, 17
 [VALUE] dial 4
 [VALUE] slider 4, 27
 Velocity 27, 52, 70, 72, 146
 Arpeggiator 5, 131
 Velocity crossfad 76
 Velocity Curve 124
 Velocity drumsample switching 128
 Velocity multisample switching 69
 Velocity switch 76, 78
 Velocity Zone 79
 Velocity Sample SW Lo→Hi 128
 Vibrato 25, 70, 71, 74
 Volume 3, 19, 27, 34, 36, 68, 72, 76, 82, 108
 Combination 36
 Sequencer 82
 [VOLUME] slider 3

W

Wah 25, 71, 72, 74
 Write 5, 55
 Arpeggiator 29, 30
 Global settings, User drum kits, User arpeggio patterns 58
 Program, Combination 34, 36, 56
 Realtime controls 34
 SW1, SW2 25
 User template song 55

Z

Zero crosses 110
 ZOOM button 44

IMPORTANT NOTICE TO CONSUMERS

This product has been manufactured according to strict specifications and voltage requirements that are applicable in the country in which it is intended that this product should be used. If you have purchased this product via the internet, through mail order, and/or via a telephone sale, you must verify that this product is intended to be used in the country in which you reside.

WARNING: Use of this product in any country other than that for which it is intended could be dangerous and could invalidate the manufacturer's or distributor's warranty.

Please also retain your receipt as proof of purchase otherwise your product may be disqualified from the manufacturer's or distributor's warranty.

KORG KORG INC.

15 - 12, Shimotakaido 1 - chome, Suginami-ku, Tokyo, Japan.

Free Manuals Download Website

<http://myh66.com>

<http://usermanuals.us>

<http://www.somanuals.com>

<http://www.4manuals.cc>

<http://www.manual-lib.com>

<http://www.404manual.com>

<http://www.luxmanual.com>

<http://aubethermostatmanual.com>

Golf course search by state

<http://golfingnear.com>

Email search by domain

<http://emailbydomain.com>

Auto manuals search

<http://auto.somanuals.com>

TV manuals search

<http://tv.somanuals.com>