



---

**Kramer Electronics Ltd.**

# **USER MANUAL**

**Sync Processors Models:**

**SG-6**

**SG-7**

**SG-9**

**SG-11**

**SG-6003B**

**IMPORTANT: Before proceeding, please read paragraph entitled  
"Unpacking and Contents"**

## Table Of Contents

<b>Section</b>	<b>Name</b>	<b>Page</b>
1	INTRODUCTION	1
1.1	A Word on Sync Signals	1
1.1.1	Horizontal Sync	1
1.1.2	Sync location	2
1.2	Video Sync Processors	3
1.3	Factors Affecting Quality of Results	3
2	Specifications	4
	Specifications (cont.)	5
3	How Do I Get Started?	6
4	Unpacking and Contents	6
4.1	Optional Accessories	6
5	SYNC PROCESSORS	7
5.1	Getting to Know Your SG-6N Sync Stabilizer	7
5.2	Getting to Know Your SG-7 Sync Transcoder	8
5.3	Getting to Know Your SG-9 Video Black Burst Restorer	9
5.4	Getting to Know Your SG-11 Black Burst/Color Bar Generator	10
5.5	Getting to Know Your SG-6003B Sync Processor	11
6	INSTALLATION	12
6.1	Rack Mounting	12
6.2	Connecting To Video Devices	12
7	USING THE MACHINES	12
7.1	Powering on the machine	12
7.2	NTSC/PAL Selection (SG-6N only)	12
7.3	Looping (SG-7 only)	12
7.4	Clamping (SG-11 only)	12
8	TAKING CARE OF YOUR PROCESSOR	13
9	TYPICAL APPLICATIONS	13
9.1	Stabilizing the Video Sync	13
9.2	Black Burst/Bar Generator Connections	14
9.3	Restoring Black Burst and Image Stability	14
9.4	Transcoding Various Sync Formats	15
10	TROUBLESHOOTING	17
10.1	Power and Indicators	17
10.2	Video Signal	18

## List Of Illustrations

<b>Figure</b>	<b>Page</b>
Figure 1: Horizontal Sync	1
Figure 2: Vertical Sync	2
Figure 3: SG-6N Front/Rear Panel Features	7
Figure 4: SG-7 Front/Rear Panel Features	8
Figure 5: SG-9 Front/Rear Panel Features	9
Figure 6: SG-11 Front/Rear Panel Features	10
Figure 7: SG-6003B- Front/Rear Panel Features	11
Figure 8: Stabilizing the Video Sync	13
Figure 9: Black Burst/Bar Generator Connections	14
Figure 10: Restoring Black Burst and Image Stability	15
Figure 11: Transcoding Various Sync Formats	16
Figure 12: SG-6N Fuse Location	18

## List Of Tables

<b>Table</b>	<b>Page</b>
Table 1: Factors Affecting Quality of Results	3
Table 2: SG-6N Front/Rear Panel Features	7
Table 3: SG-7 Front/Rear Panel Features	8
Table 4: SG-9 Front/Rear Panel Features	9
Table 5: SG-11 Front/Rear Panel Features	10
Table 6: SG-6003B - Front/Rear Panel Features	11

## 1 INTRODUCTION

Congratulations on your purchase of this Kramer Electronics Sync processor. Since 1981 Kramer has been dedicated to the development and manufacture of high quality video/audio equipment. The Kramer line has become an integral part of many of the best production and presentation facilities around the world. In recent years, Kramer has redesigned and upgraded most of the line, making the best even better. Kramer's line of professional video/audio electronics is one of the most versatile and complete available, and is a true leader in terms of quality, workmanship, price/performance ratio and innovation. In addition to the Kramer line of high quality processors, such as the one you have just purchased, Kramer also offers a full line of high quality distribution amplifiers, switchers, interfaces, controllers and computer-related products. This manual includes configuration, operation and information for the following products from the Kramer line of Sync processors. All these Sync processors are similar in operation and features.

**SG-6N** - Sync Processor

**SG-7** - Sync Transcoder

**SG-9** - Sync Processor

**SG-11** - Sync to Green Adder/Stripper

**SG-6003B** - Black Burst/Bar Generator

### 1.1 A Word on Sync Signals

All video signals received by a monitor carry with them synchronization information. Whether they are analog signals (Composite, Y/C, Component and RGB) or digital (SDI, etc.), the synchronization signals are needed for proper alignment of the image on the screen. In most video formats, there are two types of sync signals: horizontal sync and vertical sync. Many problems, though sync related, are sometimes misinterpreted, and other components of the signals are blamed instead.

#### 1.1.1 Horizontal Sync

The horizontal sync in a composite video signal (often referred to as line sync) is a short, negatively directed pulse, found at the beginning of each scan line of the monitor (see Figure 1). Basically, this pulse "tells" the monitor: "be prepared, a line of data is coming". Horizontal sync resides in the blanking area (the unseen part of the signal), and so is not visible on the screen. The number of line sync pulses equals the number of video lines.

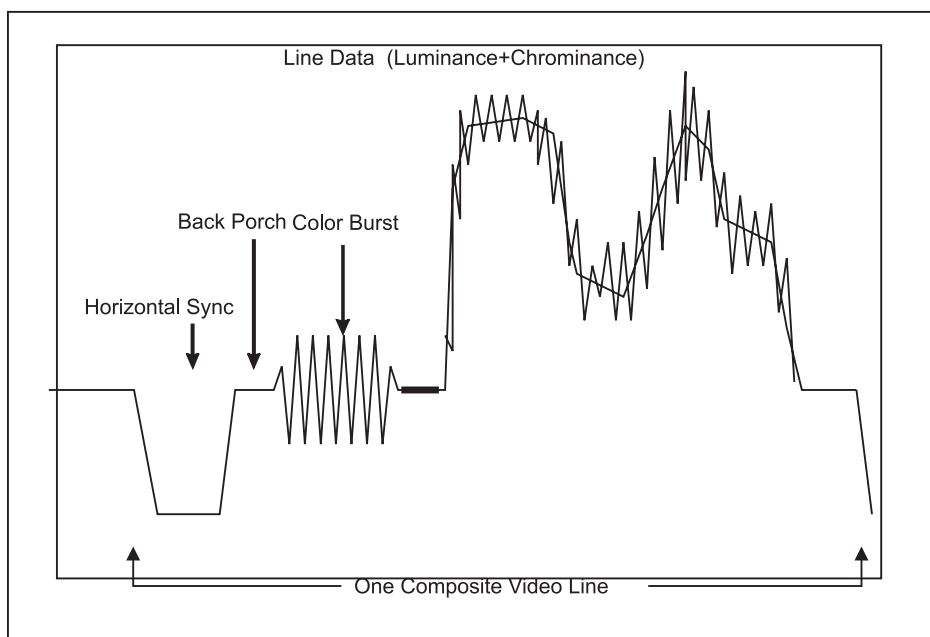

**Figure 1: Horizontal Sync**

Vertical sync, often referred to as the field sync (see Figure 2), is also a negatively directed set of pulses, found at the beginning of each video field (60 field/sec. in NTSC, 50 fields/sec. in PAL). Vertical sync is a more complicated signal than horizontal sync, which tells the monitor: “be prepared, a new field of data is coming”. Vertical sync also resides in the blanking area, and is not visible on the screen.

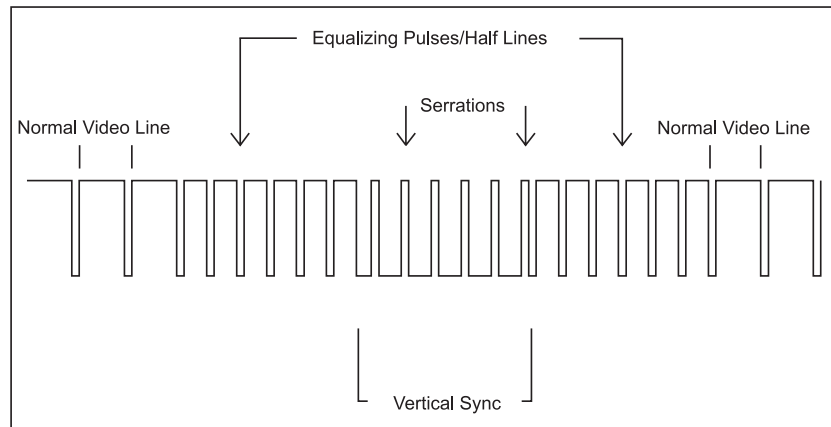

**Figure 2: Vertical Sync**

### 1.1.2 Sync location

Sync location varies according to video format, as follows:

- In the Composite video signal it is an integral part of the signal as Composite is a “package” including sync (horizontal and vertical), luminance (Y) and chrominance (color) information.
- The s-Video signal format has two parts: luminance (brightness, black & white) and chrominance (color) information. The sync signals in this format are part of the luminance (Y) signal.
- The Component video signal is comprised of three signals – luminance (Y) and two different color signals, R-Y and B-Y. The sync signals reside in the Y signal.
- When it comes to RGB (Red, Green, Blue) signals used in professional computer graphics and display applications, there are several options for the sync signals to be carried along with the data. The first and most common one is in a separate analog sync channel. This format uses 4 wires carrying signals and is called RGBS.
- Another popular format uses only three wires – Red and Blue (as in the above configuration) and Green+Sync, where the sync rides on the green signal. In this format, the signal levels are not identical as the Green signal has a larger amplitude due to the sync it carries, and the sync signals must be tripped off in order to recover the normal green sync level.
- A subset of this format inserts the sync signals in all three data channels – e.g., Red+Sync, Blue+Sync and Green+Sync.
- The format generated by a computer graphics card is normally made of 5 different signals: Red, Green, Blue, Horizontal sync and Vertical sync (sometimes referred to as Hs and Vs.) To make things more complicated, the data channels (R, G, B) are analog channels (their level varies in a continuous way from 0 to maximum) but the sync signals are digital format signals (TTL level) being either "0" or "1" (0V or 5V). To make things even more complicated, in contrast to the analog sync signals that are negatively directed pulses, the computer generated logic-level syncs can appear in both directions. Sometimes one of the syncs is positive and the other is negative, sometimes both are either positive or negative. The sync direction is dictated by the source (the graphics card) and is dependent on the required resolution. In the past, the sync direction instructed the monitor which resolution to choose. Today, most of the monitors are smarter and set the resolution automatically, but nevertheless, the cards still generate those sync signals.

- Another twist to this format is that in most cases the logic-level syncs are separated and run each in its own channel, but there are cases where the logic-level syncs come composite – joined together in the same mix of directions.
- In the digital world – SDI, DV, MPEG and other formats, the synchronization signals either travel in a special digital sync channel or, in most cases, are embedded in the digital signal.
- Due to the extensive use of sync related products, serious problems concerning sync signals may arise such as improper analog sync levels, damaged vertical sync, sync deterioration and improper polarity of the horizontal and vertical syncs.

## 1.2 Video Sync Processors

Kramer Electronics has a full line of Video Sync Processors that can perform sync stabilization, restoration and conversion in the following categories:

- **Video Sync Generators:** Generate standard video sync and black burst for studio genlock.
- **Video Sync Converters:** Convert between the different sync formats - Composite, separate H & V syncs and Analog or TTL level. One machine in this category does sync to Green adding and separating.
- **Video Sync Restorers:** Restore and re-build lost or distorted sync signals and full black burst signals.

## 1.3 Factors Affecting Quality of Results

There are many factors affecting the quality of results when signals are transmitted from a source to an acceptor as described in Table 1:

**Table 1: Factors Affecting Quality of Results**

<b>Connection cables:</b>	Low quality cables are susceptible to interference; they degrade signal quality due to poor matching and cause elevated noise levels. They should therefore be of the best quality.
<b>Sockets and connectors of the sources and acceptors:</b>	So often ignored, they should be of highest quality, since "Zero Ohm" connection resistance is the objective. Sockets and connectors also must match the required impedance (75ohm in video). Cheap, low quality connectors tend to rust, thus causing breaks in the signal path.
<b>Amplifying circuitry:</b>	Must have quality performance when the desired end result is high linearity, low distortion and low noise operation.
<b>Distance between sources and acceptors:</b>	Plays a major role in the final result. For long distances between sources and acceptors, special measures should be taken in order to avoid cable losses. These include using higher quality cables or adding line amplifiers.
<b>Interference from neighboring electrical appliances:</b>	These can have an adverse effect on signal quality. Balanced audio lines are less prone to interference, but unbalanced audio should be installed far from any mains power cables, electric motors, transmitters, etc. even when the cables are shielded.

## 2 SPECIFICATIONS

	SG-6N	SG-7
<b>Input</b>	1 Composite video, 1Vpp/75 ohms on a BNC connector.	<p><b>INPUT CHANNEL 1:</b> One composite sync &gt;0.3Vpp / 75 ohm or 1 TTL level composite sync 5 Vpp/ 47k on a BNC type connector with Hi-Z/75ohm switch, at video frequencies only.</p> <p><b>INPUTS CHANNEL 2:</b> H and V TTL level syncs, any polarity and any frequency, 5 Vpp / 47k on BNCs.</p> <p><b>INPUTS CHANNEL 3:</b> H and V looping analog syncs, &gt; 0.3Vpp / 75ohm with termination switches on BNCs, at any frequency.</p>
<b>Output</b>	1 restored composite video 1Vpp/75 ohm on BNC type connector.	<p><b>OUTPUTS CHANNEL 1:</b> H and V syncs on BNCs - TTL level, 1 Vpp when 75ohm loaded, 15khz, 50/60 Hz.</p> <p><b>OUTPUTS CHANNEL 2:</b> Composite TTL level sync on a BNC, 1Vpp when 75ohm loaded.</p> <p><b>OUTPUTS CHANNEL 3:</b> Composite analog sync 1Vpp/75ohm on a BNC and a TTL level composite sync. (or 1Vpp/75ohm analog when terminated with a 75ohm resistor) on an additional BNC.</p>
<b>Video Bandwidth</b>	25MHz -3dB	
<b>Differential Gain</b>	0.35%	
<b>Differential Phase</b>	1Deg.	
<b>Video S/N Ratio</b>	74dB	
<b>Max. Signal output</b>	2Vpp/75ohm	
<b>Dimensions (W, D, H)</b>	12cm x 6.5cm x 4.5cm 4.7" x 2.5" x 1.8"	48 x 17.8 x 1U 19" x 7" x 1U
<b>Weight</b>	0.58kg. (1.3lbs.) Approx.	2.3kg. (5.1 lbs.) Approx.
<b>Power Source</b>	12VDC, 40mA	230VAC, 50/60Hz, 3.2VA (115VAC, U.S.A.)

## SPECIFICATIONS

	SG-9	SG-11	SG-6003B
<b>Input</b>	1 composite video 1Vpp/75 ohm on a BNC.	1 Green 0.7Vpp/75 ohm One Sync 0.3Vpp/75 ohm on BNCs.	
<b>Output</b>	1 restored composite video 1Vpp/75 ohm on a BNC.	1 Sync on Green 1Vpp / 75 ohm on a BNC. 1 Green 0.7Vpp / 75 ohm, One Sync 1Vpp / 75 ohm on BNCs.	3 black burst signals, 0.3 Vpp/75 ohm, (sync) 1 color bar output 1Vpp/75ohm, 1 subcarrier output, 1Vpp/75 ohm on BNC connectors. Two audio tone @ 1kHz, 1Vpp/100ohm outputs on RCA connectors.
<b>Video Bandwidth</b>	35MHz, 1dB	21MHz, 3dB	
<b>Differential Gain</b>	0.8%		
<b>Differential Phase</b>	0.5Deg.		
<b>K-Factor</b>	0.1%		
<b>Video S/N Ratio</b>		Better than 73dB	
<b>Max. Signal output</b>	2Vpp/75ohm.	2Vpp/75ohm.	
<b>Phase Error</b>			Less than 1 degree
<b>Color Bar Saturation</b>			Preset to 75%, may be ordered at 100%
<b>Sync Oscillator</b>			Crystal controlled
<b>SC oscillator</b>			Crystal controlled
<b>Sync/SC</b>			Fully Genlocked
<b>Stability</b>			Better than 50PPM
<b>Dimensions (W, D, H)</b>	24.5cm x 18cm x 4.5cm 9.6" x 7" x 1.8"	24.5cm x 18cm x 4.5cm 9.6" x 7" x 1.8"	48 x 17.8 x 1U 19" x 7" x 1U
<b>Weight</b>	1.5kg. (3.3lbs.) Approx.	2.9kg. (6.4lbs.) Approx.	2.4kg. (5.3lbs.) Approx.
<b>Power Source</b>	230VAC, 50/60 Hz (115VAC, U.S.A.) 4.3VA.	230VAC, 50/60 Hz, (115VAC, U.S.A.) 4.1VA	230 VAC, 50/60 Hz, (115VAC, U.S.A.), 5.7VA

### 3 HOW DO I GET STARTED?

The fastest way to get started is to take your time and do everything right the first time. Taking 15 minutes to read the manual may save you a few hours later. You don't even have to read the whole manual. If a section doesn't apply to you, you don't have to spend your time reading it.

### 4 UNPACKING AND CONTENTS

The items contained in your Kramer Sync Processor package are listed below. Please save the original box and packaging materials for possible future transportation and shipment.

1. Sync Processor
2. Rubber Feet
3. User Manual
4. Kramer Concise Product Catalog
5. AC Power Cable (where applicable)

#### 4.1 Optional Accessories

The following accessories, which are available from Kramer, can enhance implementation of your machine. For information regarding cables and additional accessories, contact your Kramer dealer.

- Mechanical Rack Adapter** - Used to adapt non-standard size machines to a standard 1U rack. One or more machines may be installed on each adapter.
- VM-1015** (1:5 Video Distribution Amplifier) can be serially inserted between the sync processor and other machines for signal distribution. It is designed for studio and other demanding applications. The **VM-1015** splits a single input source into five identical outputs with no discernible signal degradation. Output signals can either be AC or DC coupled, black level or sync tip clamped, thus allowing the machine to function in all video environments. The machine may be used to distribute analog or SDI (Serial Digital) video signals, composite or single component. Video bandwidth of well over 340MHz and superb specifications make the **VM-1015** the ultimate distributor for all video applications.
- VIDEO TESTER** - A new, unique, patented, indispensable tool for the video professional, the video Tester is used to test a video path leading to/from an amplifier. By pressing only one touch switch it can trace missing signals, distinguish between good and jittery (VCR sourced) signals, and identify the presence of good signals. Whenever a video signal is missing, because of bad connections, cable breaks or faulty sources, the video Tester is all you need.



## 5 SYNC PROCESSORS

This section describes all the controls and connections of your machine. Understanding the controls and connections helps you realize the full power of your machine.

### 5.1 Getting to Know Your SG-6N Sync Stabilizer

The KRAMER SG-6N Video Sync Stabilizer replaces corrupted or missing horizontal and Vertical sync information from a video signal, especially from high generation tapes carrying time-code or teletext information which upset image stability, with standard synchronization signals. In many cases the KRAMER SG-6N can replace or enhance a TBC operation. The SG-6N restores standard sync and blanking information, eliminating instability of the video signal. The SG-6N operates in PAL and NTSC, and a rear panel mounted switch selects operation mode. The machine uses 12VDC for power supply and is therefore suitable for fieldwork as well.

Front/Rear panel features of the SG-6N are described in Figure 3 and Table 2.

#### NOTE

For operation instructions refer to section 9.

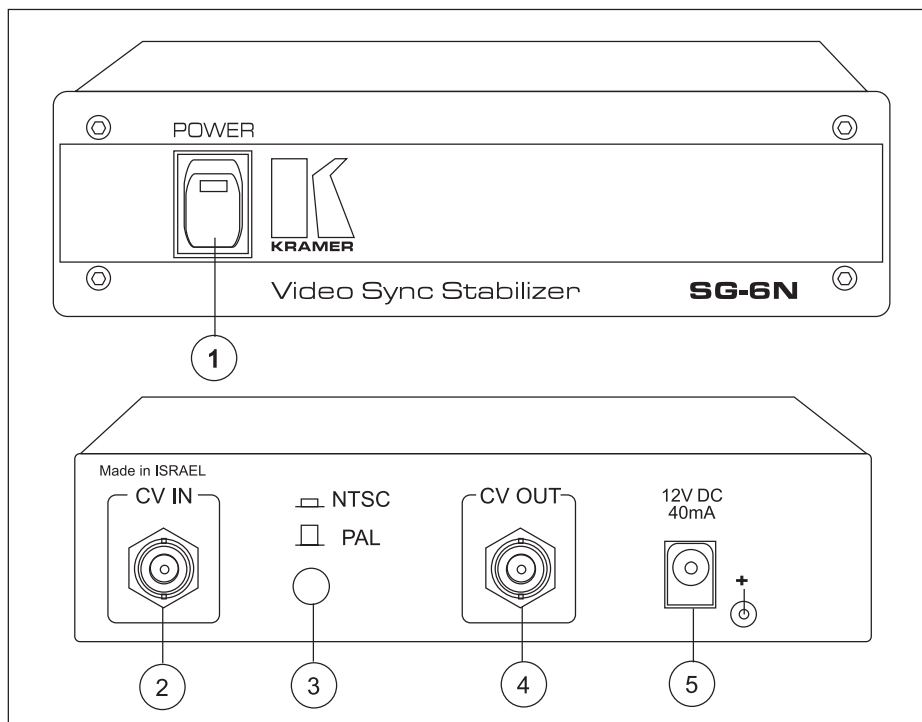

Figure 3: SG-6N Front/Rear Panel Features

Table 2: SG-6N Front/Rear Panel Features

No.	Feature	Function
1.	Power Switch	Illuminated switch: Supplies power to the unit.
2.	CV IN BNC connector	Composite video input.
3.	Switch	Selects either NTSC or PAL mode (pressed = NTSC).
4.	CV OUT BNC connector	Restored composite video output.
5.	12VDC feed connector	A DC connector that allows power to be supplied to the unit.

## 5.2 Getting to Know Your SG-7 Sync Transcoder

The KRAMER SG-7 Universal Sync Transcoder interfaces between the widely used professional video sync formats - Composite sync, Horizontal sync, Vertical sync - Analog and TTL levels. In many video studios and professional applications there is a need to convert from one format to the other, and the KRAMER SG-7 is the perfect choice - as it operates simultaneously in all directions.

Front/Rear panel features of the SG-7 are described in Figure 4 and Table 3.

### NOTE

*For operation instructions refer to section 9.*

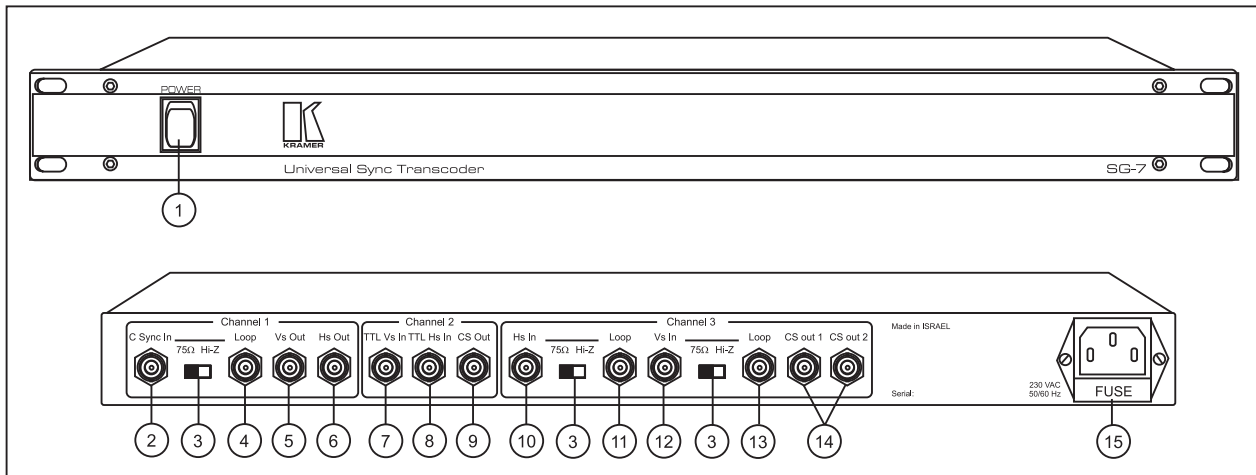

**Figure 4: SG-7 Front/Rear Panel Features**

**Table 3: SG-7 Front/Rear Panel Features**

No.	Feature	Function
1.	Power switch	Illuminated switch: Supplies power to the unit.
2.	<b>C sync In</b> BNC connector	Composite sync input.
3.	<b>75ohm/Hi-Z</b> switch	Selects "75ohm" or "HI-z" impedance when pressed (for looping select "HI-z").
4.	<b>Loop</b> BNC connector	Provides looping capability of the composite sync input.
5.	<b>Vs Out</b> BNC connector	Vertical sync output.
6.	<b>Hs Out</b> BNC connector	Horizontal sync output.
7.	<b>TTL Vs In</b> BNC connector	TTL level vertical sync input.
8.	<b>TTL Hs In</b> BNC connector	TTL level horizontal sync input.
9.	<b>CS Out</b> BNC connector	Composite sync output.
10.	<b>Hs In</b> BNC connector	Horizontal sync input.
11.	<b>Loop</b> BNC connector	Provides looping capability of the "H" input.
12.	<b>Vs In</b> BNC connector	Vertical sync input.
13.	<b>Loop</b> BNC connector	Provides looping capability of the "V" input.
14.	<b>CS Out 1, 2</b> BNC connector	Composite sync outputs.
15.	Power Connector	A 3-prong AC Connector allows power to be supplied to the unit. Directly underneath this connector, a fuse holder houses the appropriate fuse.

### 5.3 Getting to Know Your SG-9 Video Black Burst Restorer

The KRAMER SG-9 Video Black Burst Restorer replaces corrupted or missing horizontal and vertical syncs as well as color burst from a video signal with standard synchronization and color signals. In many cases the KRAMER SG-9 can replace or enhance a TBC operation. The SG-9 generates standard sync and color information from internal high quality, genlocked, sync and color generators. Front/Rear panel features of the SG-9 are described in Figure 5 and Table 4.

**NOTE**

*For operation instructions refer to section 9.*

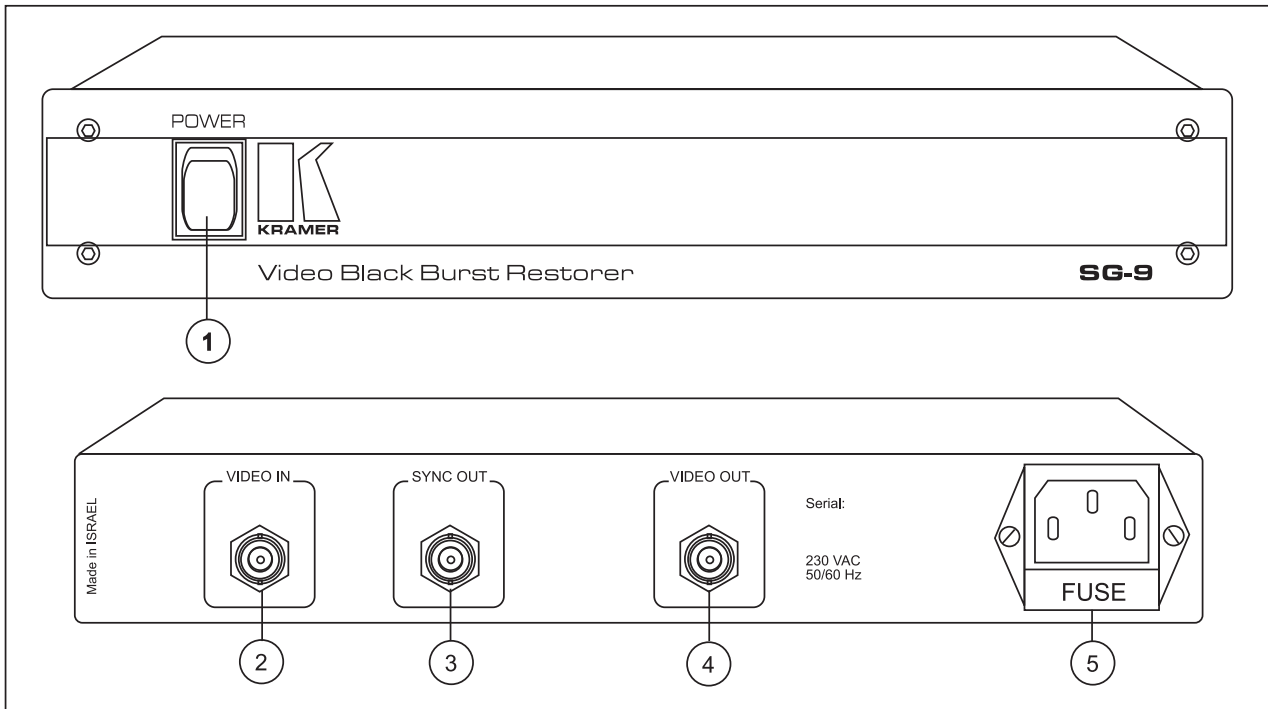

**Figure 5: SG-9 Front/Rear Panel Features**

**Table 4: SG-9 Front/Rear Panel Features**

No.	Feature	Function
1.	Power switch	Illuminated switch: Supplies power to the unit.
2.	<b>VIDEO IN</b> BNC connector	Composite video input.
3.	<b>SYNC OUT</b> BNC connector	Composite sync output.
4.	<b>VIDEO OUT</b> BNC connector	Restored composite video output.
5.	Power Connector	A 3-prong AC Connector allows power to be supplied to the unit. Directly underneath this connector, a fuse holder houses the appropriate fuse.

## 5.4 Getting to Know Your SG-11 Sync to Green Adder/Stripper

The KRAMER **SG-11** Sync to Green Adder/Stripper interfaces between the two most widely used professional Component Video formats - RGB with Sync On Green and RGBS. In many video studios and production centers there is a need to convert from one format to the other and the KRAMER **SG-11** is the perfect choice - as it operates simultaneously in both directions.

Front/Rear panel features of the **SG-11** are described in Figure 6 and Table 5.

### NOTE

For operation instructions refer to section 9.

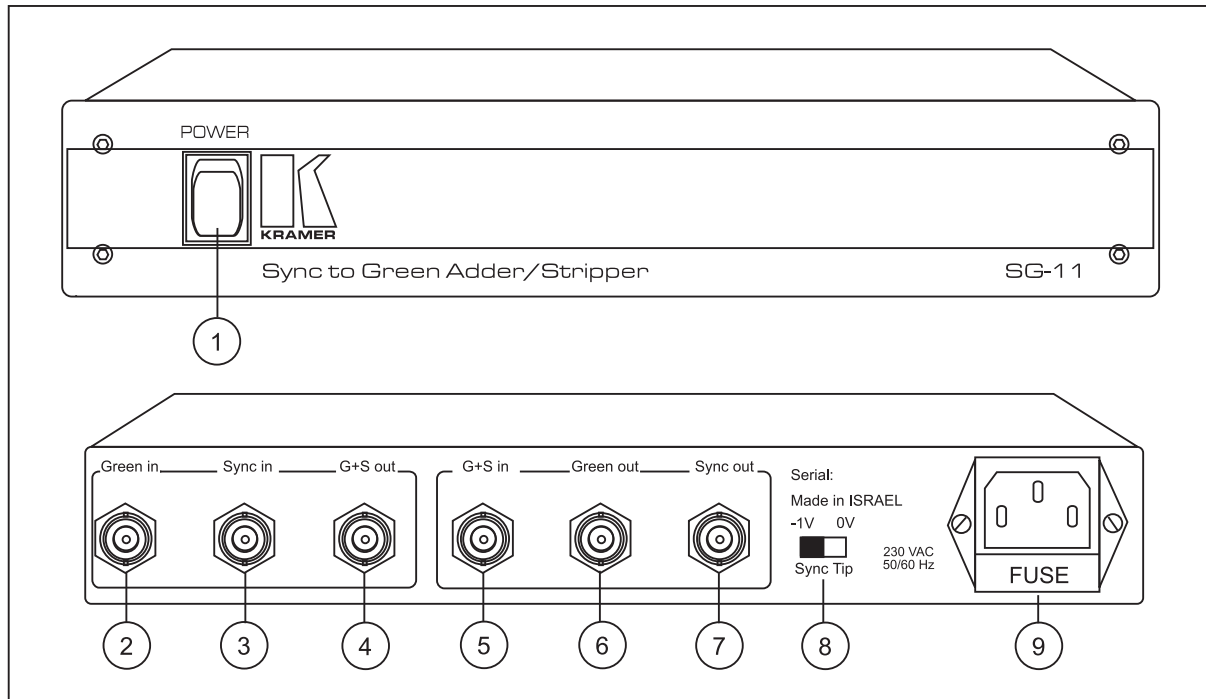

Figure 6: SG-11 Front/Rear Panel Features

Table 5: SG-11 Front/Rear Panel Features

No.	Feature	Function
1.	Power switch	Illuminated switch: Supplies power to the unit.
2.	<b>Green in</b> BNC connector	<b>Green</b> signal input.
3.	<b>Sync in</b> BNC connector	<b>Sync</b> signal input.
4.	<b>G+S out</b> BNC connector	Combined <b>Green + Sync</b> output.
5.	<b>G+S in</b> BNC connector	Combined <b>Green + Sync</b> input.
6.	<b>Green out</b> BNC connector	Separated <b>Green</b> output.
7.	<b>Sync out</b> BNC connector	Separated <b>Sync</b> output.
8.	<b>Sync Tip</b> switch	Selects either clamping the signal to a predefined -1VDC level or to 0VDC level.
9.	Power Connector	A 3-prong AC Connector allows power to be supplied to the unit. Directly underneath this connector, a fuse holder houses the appropriate fuse.

## 5.5 Getting to Know Your SG-6003B Black Burst/Color Bar Generator

The KRAMER **SG-6003B** is a broadcast level Black Burst/Color Bar Generator for video studio applications. The **SG-6003B** provides three identical Black Burst outputs, a color Subcarrier output, a Color Bar output and two 1 kHz, crystal stabilized audio outputs. State-of-the-art technology is used throughout the **SG-6003B** - crystal controlled sync and Chroma oscillators, accurate internal sync/Subcarrier genlock, both with long term stability. The number of outputs may be increased by using one of the Kramer Broadcast video DAs, e.g., **VM-1010**, **VM-1015**, **VM-1021**, etc.

Front/Rear panel features of the **SG-6003B** are described in Figure 7 and Table 6.

### NOTE

For operation instructions refer to section 8.

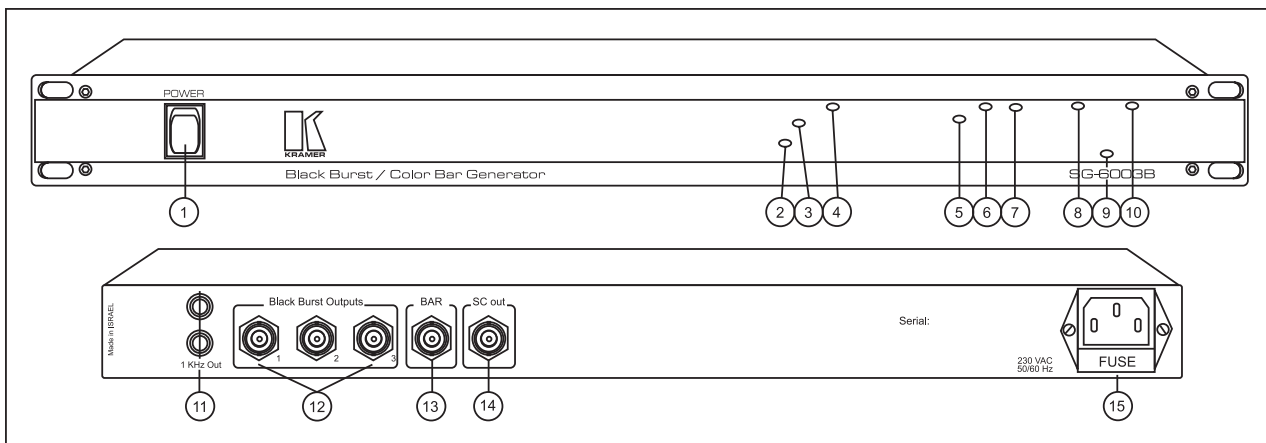

Figure 7: SG-6003B- Front/Rear Panel Features

Table 6: SG-6003B - Front/Rear Panel Features

No.	Feature	Function
1.	Power switch	Illuminated switch: Supplies power to the unit.
2.	Internal trimmers (bottom accessible)	Not for user adjustments. <b>WARNING!</b> Adjustments or attempted adjustments of the trimmers is not allowed. Failure to comply with this warning may damage the machine.
3.		
4.		
5.		
6.		
7.		
8.		
9.		
10.		
11.	<b>1KHz Out</b> RCA connectors	<b>1KHz</b> crystal stabilized audio outputs.
12.	<b>Black Burst Outputs</b> BNC connectors	<b>Black Burst</b> identical outputs.
13.	<b>BAR</b> BNC connector	Color bar output.
14.	<b>SC out</b> BNC connector	Color subcarrier output.
15.	Power Connector	A 3-prong AC connector allows power to be supplied to the unit. Directly underneath this connector, a fuse holder houses the appropriate fuse.

## 6 INSTALLATION

### 6.1 Rack Mounting

The SG-7 and the SG-6003B can be rack mounted in a standard 19" (1U) EIA rack, and include rack "ears" at the ends of the front panel. To rack mount these machines, simply place the unit's ears against the rack rails of your rack, and insert standard screws through each of the four corner holes. The SG-6N, SG-9 and the SG-11 can be rack mounted using a special adapter (see section 4.1). None of these devices require any specific spacing for ventilation above or below the unit.

### 6.2 Connecting To Video Devices

Video sources and output devices (such as recorders) may be connected to the machines through the BNC type connectors located on the back of the unit. Unused inputs are terminated to 75ohm, and active inputs should be terminated by the connecting source.

## 7 USING THE MACHINES

### 7.1 Powering on the machine

#### NOTES

- The machine should only be powered on, after all connections are completed, and all source devices have been powered on. Do not attempt to connect or disconnect any video to the machine while it is powered on!
- The socket-outlet should be near the equipment and should be easily accessible. To fully disconnect equipment, remove power cord from socket.

- 1) Press the power switch on the machine's front panel and verify that it glows.
- 2) Operate the acceptors.

### 7.2 NTSC/PAL Selection (SG-6N only)

There are several different video standards used in different countries. The leading standards are PAL, used in most European countries, NTSC used in the US, in Japan and some other countries and SECAM, which is used mainly in France, and some other countries. Each standard uses different color encoding schemes. Sync related problems might be encountered during NTSC or PAL operation include:

- 1) Problems with the sync information carried along with the video signal.
- 2) Problems of sync signal compatibility with the users' system.

To select PAL or NTSC, simply select the required system using the **NTSC/PAL** switch located on the rear panel (pressed = NTSC).

### 7.3 Looping (SG-7 only)

The looping function enables the operator to connect several machines to a video source. The operator must always switch the termination switch of the **first** and **middle** machines to "**Hi-z**". The **last** machine's termination switch should always be at "**75ohm**" to maintain well-matched lines (of 75ohm impedance) from the first to the last machine. If the looping function is not used, the termination switch should be set to "**75 ohm**".

### 7.4 Clamping (SG-11 only)

Clamping is an electronic process which corrects line-by-line the video blanking level or "**sync tip**" by clamping it to a predefined DC level. The process reduces the DC level changes when switching between different sources, eliminates picture jumps on the screen, the accumulation of low frequency noise and instability. Clamping also increases the dynamic range of video devices by limiting the average picture changes, which stress the video device. When dealing with composite video signals, it is recommended to perform DC clamping to -1V and RGB signals should be clamped to 0V. Unwanted DC offsets can also be

removed in the same way by performing proper clamping. To clamp the DC level to -1V or 0V select the desired level using the -1V/0V switch located on the machine's rear panel.

## 8 TAKING CARE OF YOUR PROCESSOR

Do not locate your processor in an environment where it is susceptible to dust or moisture and temperature and humidity may be excessive. All of these may damage the electronics, and cause erratic operation or failure. Do not clean your processor with abrasives or strong cleaners. Doing so may remove or damage the finish, or may allow moisture to build up. Take care not to allow dust or particles to build up inside unused or open connectors.

## 9 TYPICAL APPLICATIONS

### 9.1 Stabilizing the Video Sync

As the sync information is vital for video image stability on the screen, deterioration or loss of the sync signals affects image stability. Both Horizontal and Vertical sync signals are crucial for image stability and proper image centering on the screen. When the sync signals are damaged during transmission or recording they may be recovered by a sync restoring device. Another problem of sync compatibility is a result of the many standards for transferring the sync information with the signal: sync signals may come in analog form, as a composite sync signal, in digital form, either as composite or separate Horizontal and Vertical, positive direction or negative. The sync signals may be part of the luminance signals or ride on a video component signal such as the "Green" signal. To solve this compatibility problem, special devices such as sync format converters are needed. Typical video sync stabilization is described in Figure 8: A corrupted video signal is applied to a Video Sync Stabilizer's input (SG-6N in this case). The SG-6N removes of unwanted interference and signal distortions and the restored signal is outputted to an appropriate acceptor.

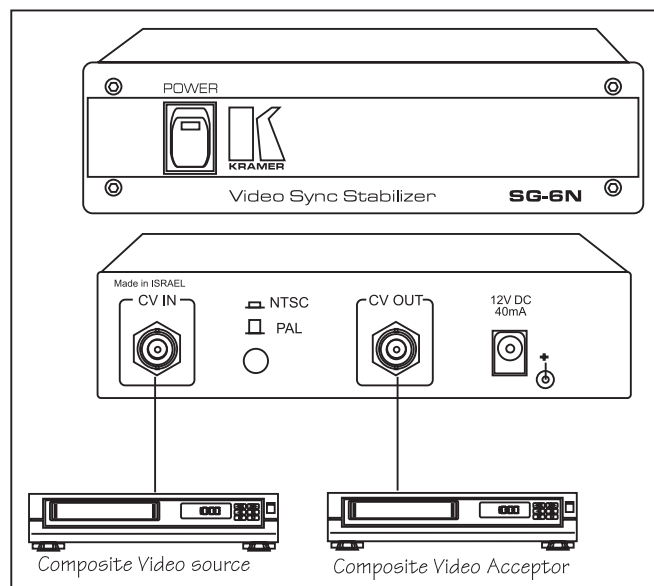

Figure 8: Stabilizing the Video Sync

## 9.2 Black Burst/Bar Generator Connections

Figure 9 describes typical usage of a Black Burst/Bar Generator, where the SG-6003B functions as a test and alignment tool for the audio and video acceptors and can provide black or color reference bar for cameras that need a stable reference. A Subcarrier signal is also provided to a Chroma Keyer/Mixer for special effects operation.

Perform the following steps (as necessary):

- 1) Connect an audio acceptor to the **1 kHz Out RCA** connectors of the SG-6003B.
- 2) Connect the **BNC Black Burst Outputs** connectors of the SG-6003B to genlockable acceptors/sources.
- 3) Connect the **BAR BNC** connector to a video monitor.
- 4) Connect the **SC Out BNC** connector to a Chroma Keyer/Mixer.
- 5) Operate sources/acceptors, mixer and the SG-6003B.

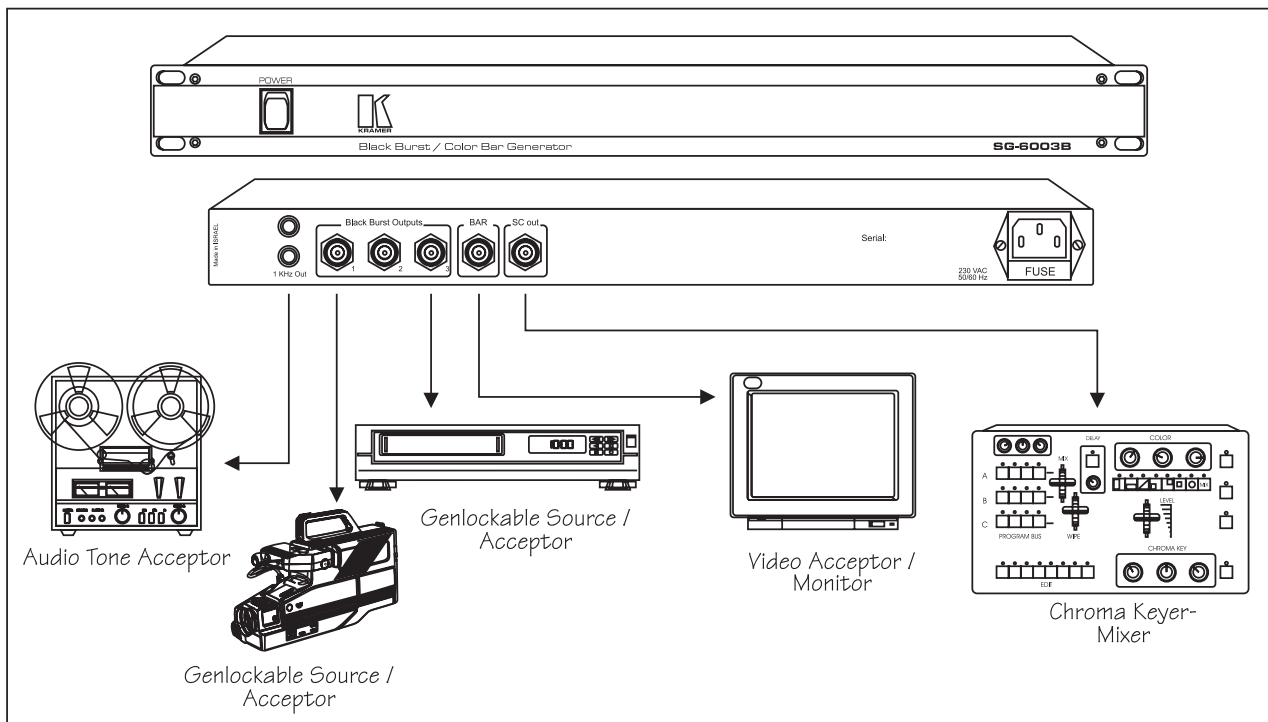

**Figure 9: Black Burst/Bar Generator Connections**

## 9.3 Restoring Black Burst and Image Stability

Figure 10 illustrates typical usage of a Kramer Sync processor (SG-9 in this case): an unstable video signal, coming from a video source is connected to the SG-9, in order to restore the bad image. A video acceptor is connected to the SG-9 output and receives the restored image.

Perform the following steps (as necessary):

- 1) Connect the output from your video source to the **VIDEO IN** BNC connector of the SG-9.
- 2) Connect the **VIDEO OUT** connector of the SG-9 to an appropriate acceptor.
- 3) Operate sources/acceptors and the SG-9.



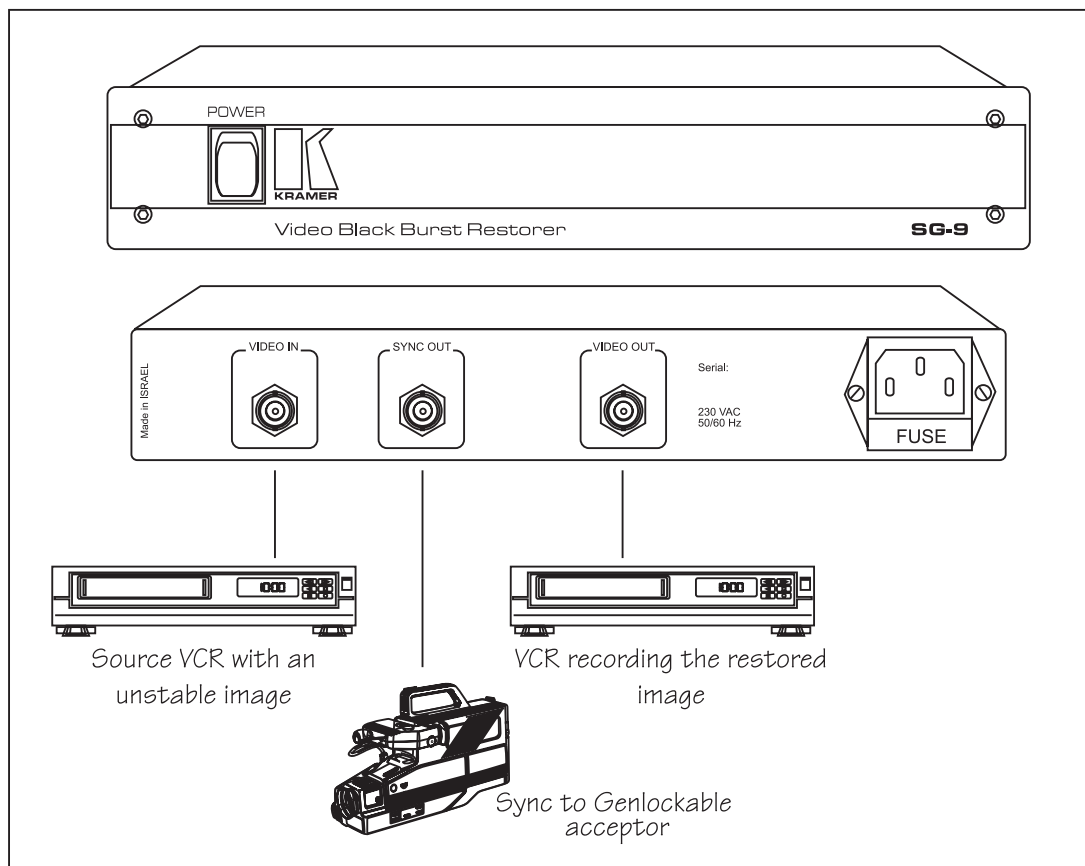
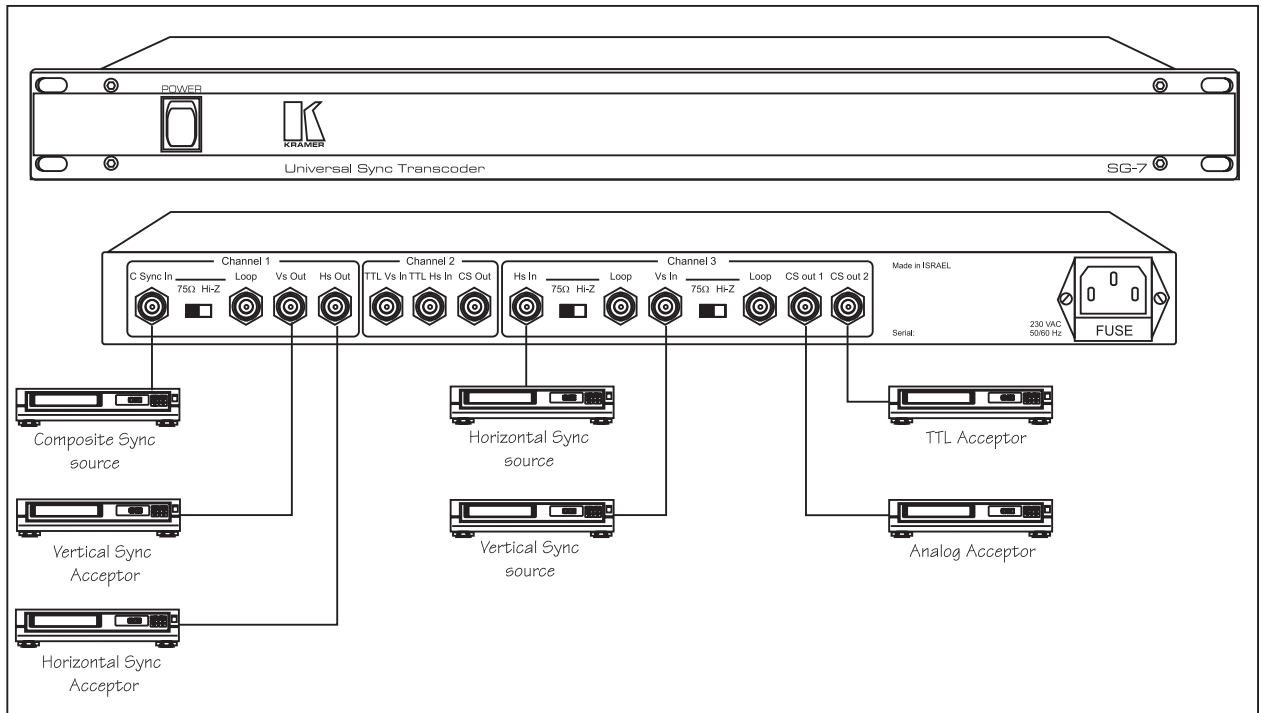

**Figure 10: Restoring Black Burst and Image Stability**

## 9.4 Transcoding Various Sync Formats

Transcoding between various video sync formats can be performed by the SG-7, as described in Figure 11. Perform the following steps (as necessary):

- 1) Connect a composite sync source to the **C Sync In** BNC connector of **CHANNEL 1**. If looping is not needed, switch the termination switch to "**75ohm**" position.
- 2) Connect TTL level H & V syncs into the inputs of **CHANNEL 2**.
- 3) Connect ANALOG H & V syncs into the inputs of **CHANNEL 3**. If looping is not needed, switch the termination switch to "**75ohm**" position.
- 4) Connect all acceptors to the appropriate outputs. All channels can be operated simultaneously. **Channel 3** has two outputs: **CS OUT1** is analog only and **CS OUT2** is TTL level but can be converted to analog by loading this output with 75ohm load. Cross linking between inputs and outputs is allowed, however some delay will be created due to the long processing chain.
- 5) Operate source, acceptors and the SG-7.



**Figure 11: Transcoding Various Sync Formats**

## 10 TROUBLESHOOTING

### NOTES

1. Please note that if the output signal is disturbed or interrupted by very strong external electromagnetic interference, it should return and stabilize when such interference ends. If not, turn the power switch off and on again to reset the machine.
2. If the following recommended actions still do not result in satisfactory operation, please consult your KRAMER Dealer.

### 10.1 Power and Indicators

Problem	Remedy
<p><b>No Power</b></p>	<ol style="list-style-type: none"> <li>1. Confirm that the rocker switch is in the “ON” position, and that the light glows.</li> <li>2. Confirm that power connections are secured at the machine and at the receptacle. Make sure the mains receptacle is active (SG-7, SG-9, SG-11, SG-6003B) or that the DC power supply is operational (SG-6N).               <ul style="list-style-type: none"> <li>◆ For the SG-7, SG-9, SG-11, SG-6003B perform the following:                   <ol style="list-style-type: none"> <li>1. If still there is no power, remove power cord from AC outlet and then, using a flat head screwdriver, remove the fuse holder located directly below the power connector on your machine. Confirm that the fuse is good by looking for the wire connected between the ends of the fuse. If the wire is broken, replace the fuse with another, with the same rating.</li> </ol> </li> <li>◆ For the SG-6N perform the following:                   <ol style="list-style-type: none"> <li>1. Using a Philips screwdriver, remove the 4 side screws attaching the machine's cover.</li> <li>2. Locate the fuse holder inside your machine (see Figure 12). Confirm that the fuse is good by looking for the wire connected between the ends of the fuse. If this wire is broken, replace the fuse with another, with the same rating.</li> <li>3. Install cover by replacing the Philips screws.</li> </ol> </li> </ul> </li> </ol>

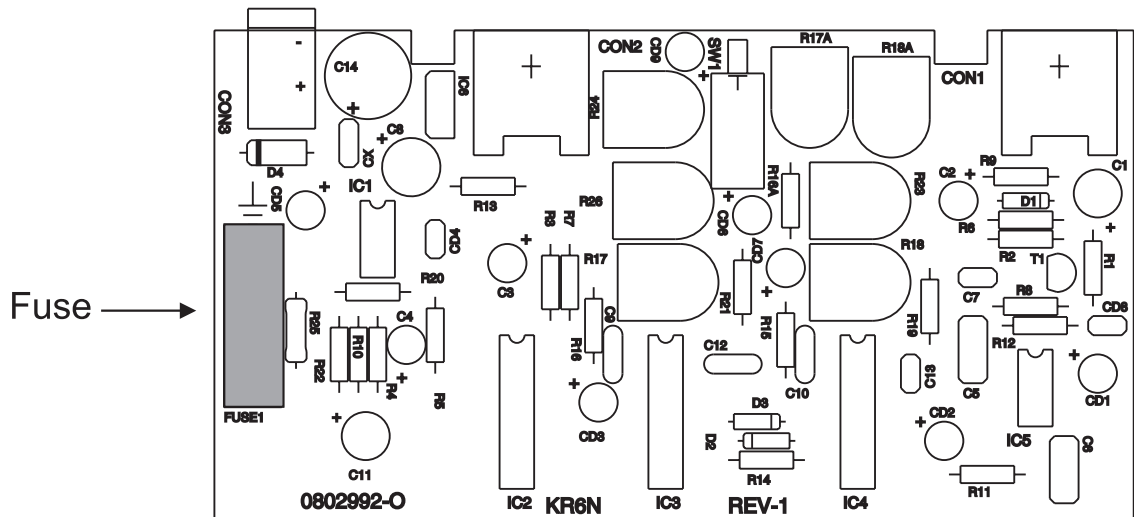

Figure 12: SG-6N Fuse Location

## 10.2 Video Signal

Problem	Remedy
<b>No video at the output device</b>	<ol style="list-style-type: none"> <li>1. Confirm that your source and output devices are powered on and connected properly. The input of your machine should be of an identical signal format at the output of your source. Signals at the output of your machine should be of an identical signal format as at the input of your display.</li> <li>2. Confirm that any other device in the signal path have the proper input and/or output selected.</li> <li>3. Use the Video Tester to help trace faulty cables and equipment (see section 4.1).</li> </ol>
<b>Video level is too high or too dim.</b>	<ol style="list-style-type: none"> <li>1. Verify that the lines are well matched through 75ohm impedance; otherwise it results in a video level that is too high or too dim.</li> <li>2. Confirm that the connecting cables are of high quality and properly inserted.</li> <li>3. Check level controls located on your source input device or output display.</li> </ol>
<b>Noise bars are "rolling" up or down in the output image</b> <b>or:</b> <b>Low Frequency Hum in the output signal</b>	<p>Hum bars (ground loop) are caused by a difference in the ground potential of any two or more devices connected to your signal path. This difference is compensated by passing that voltage difference through any available interconnection, including your cables.</p> <p style="text-align: center;"><b>WARNING!</b> <i>Do not disconnect the ground from any piece of equipment in your signal path!</i></p> <p>Check the following to remove hum bars:</p> <ol style="list-style-type: none"> <li>1. Confirm that all interconnected equipment is connected to the same phase of power, if possible.</li> <li>2. Remove equipment connected to that phase that may introduce noise, such as motors, generators, etc.</li> <li>3. Disconnect all interconnecting cables and reconnect them one at a time until the ground loop reappears. Disconnect the affected cable and replace, or insert an isolation transformer in the signal path.</li> <li>4. Use a video Isolator, such as Kramer OC-1N or a differential amplifier such as Kramer 123V inserted in the video signal path.</li> </ol>



---

## LIMITED WARRANTY

Kramer Electronics (hereafter Kramer) warrants this product to be free from defects in material and workmanship under the following terms.

### HOW LONG IS THE WARRANTY

Labor and parts are warranted for three years from the date of the first customer purchase.

### WHO IS PROTECTED

Only the first purchase customer may enforce this warranty.

### WHAT IS COVERED AND WHAT IS NOT COVERED

Except as below, this warranty covers all defects in material or workmanship in this product. The following are not covered by the warranty:

- 1) Any product which is not distributed by Kramer or which is not purchased from an authorized Kramer dealer. If you are uncertain as to whether a dealer is authorized, please contact Kramer at one of the agents listed in the web site **www.kramerelectronics.com**.
- 2) Any product, on which the serial number has been defaced, modified or removed.
- 3) Damage, deterioration or malfunction resulting from:
  - a) Accident, misuse, abuse, neglect, fire, water, lightning or other acts of nature.
  - b) Unauthorized product modification, or failure to follow instructions supplied with the product.
  - c) Repair or attempted repair by anyone not authorized by Kramer.
  - d) Any shipment of the product (claims must be presented to the carrier).
  - e) Removal or installation of the product.
  - f) Any other cause, which does not relate to a product defect.
  - g) Cartons, equipment enclosures, cables or accessories used in conjunction with the product.

### WHAT WE WILL PAY FOR AND WHAT WE WILL NOT PAY FOR

We will pay labor and material expenses for covered items. We will not pay for the following:

- 1) Removal or installations charges.
- 2) Costs of initial technical adjustments (set-up), including adjustment of user controls or programming. These costs are the responsibility of the Kramer dealer from whom the product was purchased.
- 3) Shipping charges.

### HOW YOU CAN GET WARRANTY SERVICE

- 1) To obtain service on you product, you must take or ship it prepaid to any authorized Kramer service center.
- 2) Whenever warranty service is required, the original dated invoice (or a copy) must be presented as proof of warranty coverage, and should be included in any shipment of the product. Please also include in any mailing a contact name, company, address, and a description of the problem(s).
- 3) For the name of the nearest Kramer authorized service center, consult your authorized dealer.

### LIMITATION OF IMPLIED WARRANTIES

All implied warranties, including warranties of merchantability and fitness for a particular purpose, are limited in duration to the length of this warranty.

## EXCLUSION OF DAMAGES

Kramer's liability for any defective products is limited to the repair or replacement of the product at our option. Kramer shall not be liable for:

- 1) Damage to other property caused by defects in this product, damages based upon inconvenience, loss of use of the product, loss of time, commercial loss; or:
- 2) Any other damages, whether incidental, consequential or otherwise. Some countries may not allow limitations on how long an implied warranty lasts and/or do not allow the exclusion or limitation of incidental or consequential damages, so the above limitations and exclusions may not apply to you.

This warranty gives you specific legal rights, and you may also have other rights, which vary from place to place.

**NOTE:** All products returned to Kramer for service must have prior approval. This may be obtained from your dealer.

---

## NOTICE

This equipment has been tested to determine compliance with the requirements of:

- EN-50081:** "Electromagnetic compatibility (EMC);  
Generic emission standard.  
Part 1: Residential, commercial and light industry"
- EN-50082:** "Electromagnetic compatibility (EMC) generic immunity standard. Part 1:  
Residential, commercial and light industry environment".
- CFR-47** FCC Rules and Regulations:  
Part 15- "Radio frequency devices:  
Subpart B- Unintentional radiators

## CAUTION!

- Any user who makes changes or modifications to the unit without the express approval of the manufacturer will void warranty and user authority to operate the equipment. Only a qualified technician approved by Kramer Electronics should service the machine.
- Use the supplied AC power cord (when applicable) to supply power to the machine and controllers.
- Please use recommended interconnect cables to connect the machine to controllers and other components.

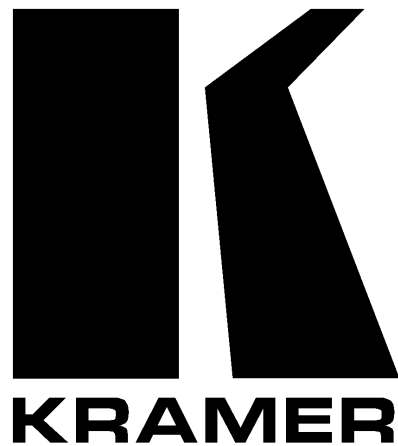

**The list of Kramer distributors appears on our web site:  
[www.kramerelectronics.com](http://www.kramerelectronics.com)  
From the web site it is also possible to e-mail factory headquarters.  
We welcome your questions, comments and feedback.**

---

**Kramer Electronics Ltd.**

3 Am VeOlamo Street. Jerusalem 95463, Israel Tel: (972-2)-654-4000. Fax: (972-2)-653-5369  
e-mail: [kramerel@netvision.net.il](mailto:kramerel@netvision.net.il)

## Free Manuals Download Website

<http://myh66.com>

<http://usermanuals.us>

<http://www.somanuals.com>

<http://www.4manuals.cc>

<http://www.manual-lib.com>

<http://www.404manual.com>

<http://www.luxmanual.com>

<http://aubethermostatmanual.com>

Golf course search by state

<http://golfingnear.com>

Email search by domain

<http://emailbydomain.com>

Auto manuals search

<http://auto.somanuals.com>

TV manuals search

<http://tv.somanuals.com>