

# Integra®

## A / V Receiver

# *DTR-7* *DTR-6*

## Instruction Manual

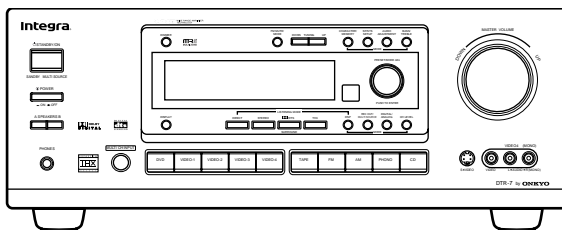

Thank you for purchasing the Integra Audio Video Control Receiver.

Please read this manual thoroughly before making connections and turning on the power.

Following the instructions in this manual will enable you to obtain optimum performance and listening enjoyment from your new Audio Video Control Receiver.

Please retain this manual for future reference.

## Contents

### Before using

Important Safeguards .....	2
Precautions .....	3
Features .....	4
Supplied accessories .....	4
Before operating this unit .....	5

### Preparation

Audio equipment connections .....	6
Video equipment connections .....	8
Connecting equipment with 5.1-channel output .....	9
Connecting speakers .....	10
Connecting power amplifiers .....	12
Connecting an equalizer .....	13
Connecting the power .....	13
Making antenna connections .....	14

### Operation

Using the on-screen display .....	16
Setting the speaker configuration .....	18
Setting the speaker distance .....	20
Setting the speaker Level .....	21
Playing a digital source .....	23
Presetting FM/AM radio stations .....	24
Selecting an input source .....	26
Selecting a preset station .....	32
Playing a multichannel input source .....	33
Using the Listening Modes .....	34
Setting the listening mode parameters .....	38
Assigning a video source to each audio input source .....	40
Giving a name to each input source and preset radio station .....	41
Adjusting the output level of each speaker while listening to it .....	42
Other setup operations .....	43
Recording a source .....	44
Using Multi-Room Remote System .....	46
The initial settings .....	48

### Appendix

Using the remote controller .....	49
Programming the remote controller codes of other devices into the RC-392M .....	52
Using a Macro function .....	54
Troubleshooting guide .....	58
Specifications .....	60
Control positions and names .....	62

**WARNING:**

TO REDUCE THE RISK OF FIRE OR ELECTRIC SHOCK, DO NOT EXPOSE THIS APPLIANCE TO RAIN OR MOISTURE.

**CAUTION:**

TO REDUCE THE RISK OF ELECTRIC SHOCK, DO NOT REMOVE COVER (OR BACK). NO USER-SERVICEABLE PARTS INSIDE. REFER SERVICING TO QUALIFIED SERVICE PERSONNEL.



**WARNING**  
RISK OF ELECTRIC SHOCK  
DO NOT OPEN

**AVIS**  
RISQUE DE CHOC ELECTRIQUE  
NE PAS OUVRIR



The lightning flash with arrowhead symbol, within an equilateral triangle, is intended to alert the user to the presence of uninsulated "dangerous voltage" within the product's enclosure that may be of sufficient magnitude to constitute a risk of electric shock to persons.



The exclamation point within an equilateral triangle is intended to alert the user to the presence of important operating and maintenance (servicing) instructions in the literature accompanying the appliance.

## Important Safeguards

1. **Read Instructions** – All the safety and operating instructions should be read before the appliance is operated.
2. **Retain Instructions** – The safety and operating instructions should be retained for future reference.
3. **Heed Warnings** – All warnings on the appliance and in the operating instructions should be adhered to.
4. **Follow Instructions** – All operating and use instructions should be followed.
5. **Water and Moisture** – The appliance should not be used near water – for example, near a bathtub, washbowl, kitchen sink, laundry tub, in a wet basement, or near a swimming pool, and the like.
6. **Carts and Stands** – The appliance should be used only with a cart or stand that is recommended by the manufacturer.
 

PORTABLE CART WARNING



S3125A
- 6A. An appliance and cart combination should be moved with care. Quick stops, excessive force, and uneven surfaces may cause the appliance and cart combination to overturn.
7. **Wall or Ceiling Mounting** – The appliance should be mounted to a wall or ceiling only as recommended by the manufacturer.
8. **Ventilation** – The appliance should be situated so that its location or position does not interfere with its proper ventilation. For example, the appliance should not be situated on a bed, sofa, rug, or similar surface that may block the ventilation openings; or if placed in a built-in installation, such as a bookcase or cabinet that may impede the flow of air through the ventilation openings, there should be free space of at least 20 cm (8 in.) and an opening behind the appliance.
9. **Heat** – The appliance should be situated away from heat sources such as radiators, heat registers, stoves, or other appliances (including amplifiers) that produce heat.
10. **Power Sources** – The appliance should be connected to a power supply only of the type described in the operating instructions or as marked on the appliance.
11. **Polarization** – If the appliance is provided with a polarized plug having one blade wider than the other, please read the following information:  
The polarization of the plug is a safety feature. The polarized plug will only fit the outlet one way. If the plug does not fit fully into the outlet, try reversing it. If there is still trouble, the user should seek the services of a qualified electrician. Under no circumstances should the user attempt to defeat the polarization of the plug.
12. **Power-Cord Protection** – Power-supply cords should be routed so that they are not likely to be walked on or pinched by items placed upon or against them, especially near plugs, convenience receptacles, and the point where they exit from the appliance.
13. **Cleaning** – The appliance should be cleaned only as recommended by the manufacturer.
14. **Power Lines** – An outdoor antenna should be located away from power lines.
15. **Nonuse Periods** – The power cord of the appliance should be unplugged from the outlet when left unused for a long period of time.
16. **Object and Liquid Entry** – Care should be taken so that objects do not fall and liquids are not spilled into the enclosure through openings.
17. **Damage Requiring Service** – The appliance should be serviced by qualified service personnel when:
  - A. The power-supply cord or the plug has been damaged;
  - B. Objects have fallen, or liquid has been spilled into the appliance; or
  - C. The appliance has been exposed to rain; or
  - D. The appliance does not appear to operate normally or exhibits a marked change in performance; or
  - E. The appliance has been dropped, or the enclosure damaged.
18. **Servicing** – The user should not attempt to service the appliance beyond that described in the operating instructions. All other servicing should be referred to qualified service personnel.
19. **Outdoor Antenna Grounding** – If an outside antenna is connected to the receiver, be sure the antenna system is grounded so as to provide some protection against voltage surges and built up static charges. Article 810 of the National Electrical Code, ANSI/NFPA 70, provides information with regard to proper grounding of the mast and supporting structure, grounding of the lead-in wire to an antenna-discharge unit, size of grounding conductors, location of antenna-discharge unit, connection to grounding electrodes, and requirements for the grounding electrode. See Figure 1.

FIGURE 1:  
EXAMPLE OF ANTENNA GROUNDING AS PER NATIONAL ELECTRICAL CODE

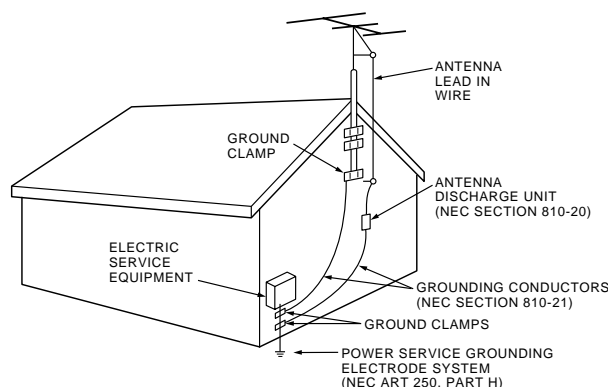

NEC – NATIONAL ELECTRICAL CODE

S2898A

# Precautions

---

## 1. Warranty Claim

You can find the serial number on the rear panel of this unit. In case of warranty claim, please report this number.

## 2. Recording Copyright

Recording of copyrighted material for other than personal use is illegal without permission of the copyright holder.

## 3. AC Fuse

The fuse is located inside the chassis and is not user-serviceable. If power does not come on, contact your Onkyo authorized service station.

## 4. Care

From time to time you should wipe the front and rear panels and the cabinet with a soft cloth. For heavier dirt, dampen a soft cloth in a weak solution of mild detergent and water, wring it out dry, and wipe off the dirt. Following this, dry immediately with a clean cloth. Do not use rough material, thinners, alcohol or other chemical solvents or cloths since these could damage the finish or remove the panel lettering.

## 5. Power

### WARNING

BEFORE PLUGGING IN THE UNIT FOR THE FIRST TIME, READ THE FOLLOWING SECTION CAREFULLY.

The voltage of the available power supply differs according to country or region. Be sure that the power supply voltage of the area where this unit will be used meets the required voltage (e.g., AC 230 V, 50 Hz or AC 120 V, 60 Hz) written on the rear panel.

Worldwide models are equipped with a voltage selector to conform to local power supplies. Be sure to set this switch to match the voltage of the power supply in your area before plugging in the unit.

### Note to CATV system installer:

This reminder is provided to call the CATV system installer's attention to Article 820-40 of the NEC, ANSI/NFPA 70, which provides guidelines for proper grounding and, in particular, specifies that the cable ground shall be connected to the grounding system of the building, as close to the point of cable entry as practical.

### FCC Information for User

#### CAUTION:

The user changes or modifications not expressly approved by the party responsible for compliance could void the user's authority to operate the equipment.

#### NOTE:

This equipment has been tested and found to comply with the limits for a Class B digital device, pursuant to Part 15 of the FCC Rules. These limits are designed to provide reasonable protection against harmful interference in a residential installation. This equipment generates, uses and can radiate radio frequency energy and, if not installed and used in accordance with the instructions, may cause harmful interference to radio communications. However, there is no guarantee that interference will not occur in a particular installation. If this equipment does cause harmful interference to radio or television reception, which can be determined by turning the equipment off and on, the user is encouraged to try to correct the interference by one or more of the following measures:

- Reorient or relocate the receiving antenna.
- Increase the separation between the equipment and receiver.
- Connect the equipment into an outlet on a circuit different from that to which the receiver is connected.
- Consult the dealer or an experienced radio/TV technician for help.

### For Canadian model

**CAUTION:** THIS DIGITAL APPARATUS DOES NOT EXCEED THE CLASS B LIMITS FOR RADIO NOISE EMISSION FROM DIGITAL APPARATUS SET OUT IN THE RADIO INTERFERENCE REGULATIONS OF THE CANADIAN DEPARTMENT OF COMMUNICATIONS.

For models having a power cord with a polarized plug:

**CAUTION:** TO PREVENT ELECTRIC SHOCK, MATCH WIDE BLADE OF PLUG TO WIDE SLOT, FULLY INSERT.

### Modele pour les Canadien

**ATTENTION:** L'INTERFÉRENCE RADIO ÉLECTRIQUE GÉNÉRÉE PAR CET APPAREIL NUMÉRIQUE DE TYPE B NE DÉPASSE PAS LES LIMITES ÉNONCÉES DANS LE RÈGLEMENT SUR LES PERTURBATIONS RADIO ÉLECTRIQUES, SECTION APPAREIL NUMÉRIQUE, DU MINISTÈRE DES COMMUNICATIONS.

Sur les modèles dont la fiche est polarisée:

**ATTENTION:** POUR ÉVITER LES CHOCS ÉLECTRIQUES, INTRODUIRE LA LAME LA PLUS LARGE DE LA FICHE DANS LA BORNE CORRESPONDANTE DE LA PRISE ET POUSSER JUSQU'AU FOND.

# Features

## Key Features

- THX\*<sup>1</sup> select (DTR-7 only)
- DTS\*<sup>2</sup> decoder built-in
- Dolby\*<sup>3</sup> digital decoder built-in
- Linear PCM 96 kHz/24-bit D/A converter
- 5.1 multichannel inputs
- 4 assignable digital inputs (2-coaxial, 2-optical)
- Optical digital output (DTR-7 only)
- Onscreen display
- Main-in jacks for front left & right channels (DTR-7 only)
- Pre outs for all channels
- Banana-plug posts for all channels
- Aluminum volume control
- New user-friendly smart scan
- New backlit learning remote with joy stick
- 3 audio and 5 AV inputs (all S-video&video)
- Cinema Re-EQ\*<sup>4</sup>
- Multiroom Jack for compatibility with Xantech\*<sup>5</sup>, Niles\*<sup>6</sup>, and the more popular multiroom A/V distribution and control systems.

## Amplifier Design

- 5-channel amplification
- Real high-current, 6  $\Omega$  low-impedance drive
- DVD-audio capability
- Wide Range amplifier technology
- Discrete output stage circuits for all channels
- High-quality extruded heat sink
- Oversized power transformer
- (DTR-7)  
105 W x 5 (8  $\Omega$  20 Hz-20 kHz 0.08% THD FTC)  
135 W x 5 (6  $\Omega$  1 kHz 0.1% THD FTC)
- (DTR-6)  
85 W x 5 (8  $\Omega$  20 Hz-20 kHz 0.08% THD FTC)  
110 W x 5 (6  $\Omega$  1 kHz 0.1% THD FTC)

\*1 Lucasfilm and THX are registered trademarks of Lucasfilm LTD.

\*2 Manufactured under license from Digital Theater Systems, Inc. US Pat. No.5,451,942 and other worldwide patents issues and pending. "DTS" and "DTS Digital Surround" are trademarks of Digital Theater Systems, Inc.© 1996 Digital Theater Systems, Inc. All rights reserved.

\*3 Manufactured under license from Dolby Laboratories. "Dolby", "Pro Logic" and the double-D symbol are trademarks of Dolby Laboratories. Confidential Unpublished Works. ©1992-1997 Dolby Laboratories, Inc. All rights reserved.

\*4 Re-Equalization and the "Re-EQ" logo are trademarks of Lucasfilm Ltd. Manufactured under license of Lucasfilm Ltd.

\*5 Xantech is a registered trademark of Xantech Corporation.

\*6 Niles is a registered trademark of Niles Audio Corporation.

# Supplied accessories

Check that the following accessories are supplied with this unit.

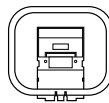

AM loop antenna x 1

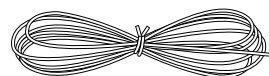

FM antenna x 1  
(Connector shape may vary depending on where the unit is purchased.)

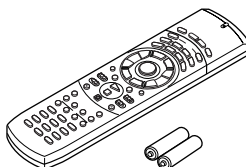

Remote controller (RC-392M) x1  
Batteries (size AA or UM-3) x 2

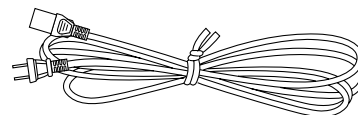

Power cable x1

## Memory Preservation

This unit does not require memory preservation batteries. A built-in memory power back-up system preserves the contents of the memory during power failures and even when the POWER switch is set to off. The POWER switch must be set to on in order to charge the back-up system.

The memory preservation period after the unit has been turned off varies depending on climate and placement of the unit. On the average, memory contents are protected over a period of a few weeks after the last time the unit has been turned off. This period is shorter when the unit is exposed to a highly humid climate.

## THX Select

Before any home theatre component can be THX Select certified, it must pass a rigorous series of quality and performance tests. Only then can a product feature the THX Select logo, which is your guarantee that the Home Theatre products you purchase will give you superb performance for many years to come. THX Select requirements define hundreds of parameters, including power amplifier performance, and pre-amplifier performance and operation for both digital and analog domains. THX Select receivers also features proprietary THX technologies (e.g. THX Mode, see page 34) which accurately translate film soundtracks for home theater playback.

# Before operating this unit

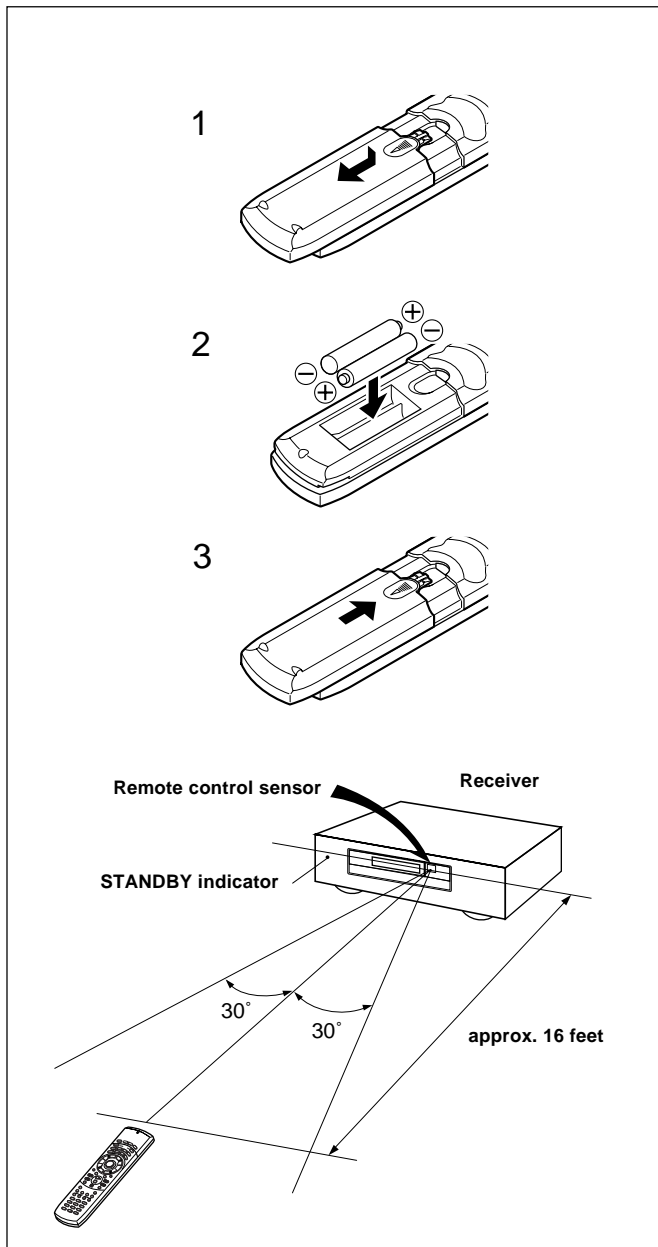

## Installing the remote controller batteries

1. Remove the battery compartment cover by pressing the tab and lifting up the cover.
2. Insert two AA (R6- or UM-3)-size batteries into the battery compartment. Carefully follow the polarity diagram (positive (+) and negative (-) symbols) inside the battery compartment.
3. After batteries are installed and seated correctly, replace the compartment cover.

### Notes

- Do not mix new batteries with old batteries or different kinds of batteries.
- To avoid corrosion, remove the batteries if the remote controller is not to be used for a long time.
- Remove dead batteries immediately to avoid damage from corrosion. If the remote controller does not operate smoothly, replace both the batteries at the same time.
- The life of the batteries supplied is about six months but this will vary depending on usage.

## Using the remote controller

Point the remote controller toward the remote control sensor. The STANDBY indicator lights up when the unit receives a signal from the remote controller.

### Notes

- Place the unit away from strong light such as direct sunlight or inverted fluorescent light which can prevent proper operation of the remote controller.
- Using another remote controller of the same type in the same room or using the unit near equipment which uses infrared rays may cause operational interference.
- Do not put any object such as a book on the remote controller. The buttons of the remote controller may be pressed by mistake and drain the batteries.
- Make sure the audio rack doors do not have colored glass. Placing the unit behind such doors may prevent proper remote controller operation.
- If there is any obstacle between the remote controller and the remote control sensor, the remote controller will not operate.

# Audio equipment connections

- Do not plug in the power cord until all connections have been made.
- On each pair of input jacks, a red connector (marked R) corresponds to the right channel, and a white connector (marked L) to the left channel.
- Please refer to the instruction manual of each component when making any connections.
- Insert the plugs and connectors securely. Remember that improper connection can result in noise, poor performance, or damage to the equipment.
- Do not bind audio connection cables with power cords and speaker cables. Doing so may degrade sound quality.

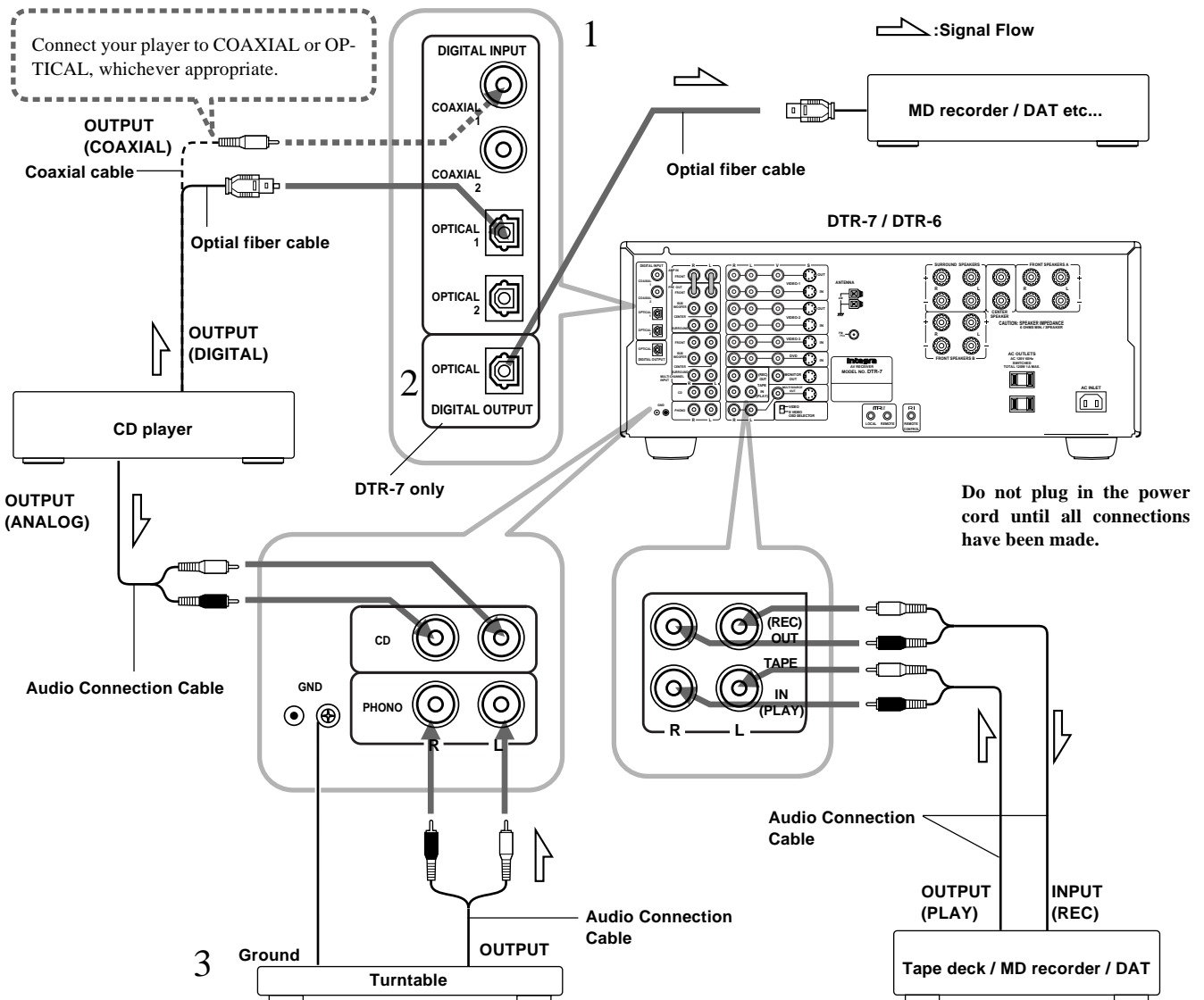
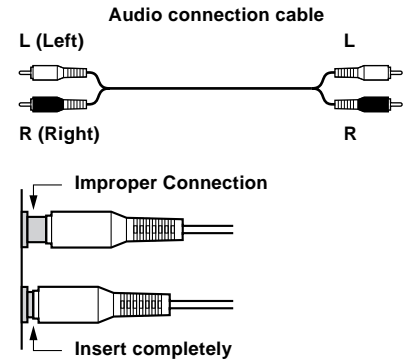

# Audio equipment connections

## 1. DIGITAL INPUT connectors

- If your CD player has a digital output connector, connect it to a proper DIGITAL INPUT connector for clear and dynamic sound play.
- This unit provides four digital input connectors to connect CD players, MD recorders, DAT decks, etc. having a digital output connector. When using these connectors, connect the unit also via the audio connection cables. You should also note that the signals you can record are analog signals only.
- The digital inputs, COAXIAL 1, 2 and OPTICAL 1, 2 can be assigned to individual input selector buttons, so when an input selector button is pressed, the assigned digital input is used instead of the corresponding analog input. (See pages 23,29.)

## 2. OPTICAL DIGITAL OUTPUT connector (DTR-7 only)

If you have a digital recorder, such as an MD recorder, DAT, and CD-R (Compact Disc Recorder), connect the recorder's digital input connector to this connector. In this case, always use commercially available optical digital audio cables.

## 3. Turntable

This receiver is designed for use with turntables using moving magnet cartridges.

Connect a ground (or earth) wire to GND terminal.

With some players, connecting a ground wire results in larger noise. If so, do not connect any ground wire.

Optical digital connector

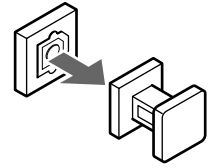

Remove the protective caps before making connections. When not in use, be sure to replace them.

**AC outlet connection**

You can connect the power cord from another audio device to the rear of this receiver. Since the AC outlets on the unit are a SWITCHED type outlet, you can use the STANDBY/ON button, to turn on/off the power to both this receiver and the connected audio devices.

First turn the POWER switch ON (  ). Make sure that the total capacity of other components connected to this unit does not exceed the capacity that is printed on the rear panel.

**DTR-7 / DTR-6**

**Connections for remote control (RI)**

You can use the remote controller of this receiver to operate cassette tape decks and compact disc players that have Onkyo/Integra **RI** connectors.

Connect a remote control cable to the connector with the **RI** mark.

- An **RI** remote control cable equipped with a 1/8 in. -diameter miniature two-conductor phone plug comes with every compact disc player or cassette tape deck that has an **RI** connector.
- Remote control operation is not possible if only the remote control cable is connected – the audio connection cables must also be connected.
- This receiver's remote controller does not support control of Onkyo turntables.
- If the connecting device has two **RI** connectors lined-up vertically or horizontally, you can use either of them. They both offer the same functionality.
- You can use the remote controller for the DTR-7/DTR-6 to control an Onkyo/Integra DVD player or MD recorder that is not connected via an **RI** cable. When you control such a DVD player or MD recorder, point the remote controller toward the sensor area of the DVD player or MD recorder.



# Video equipment connections

- On each pair of input jacks, the red connector (marked R) corresponds to the right channel, and the white connector (marked L) to the left channel.
- The yellow connector (marked V) is used for video connection.
- Please refer to the instruction manual of each component when making any connections.

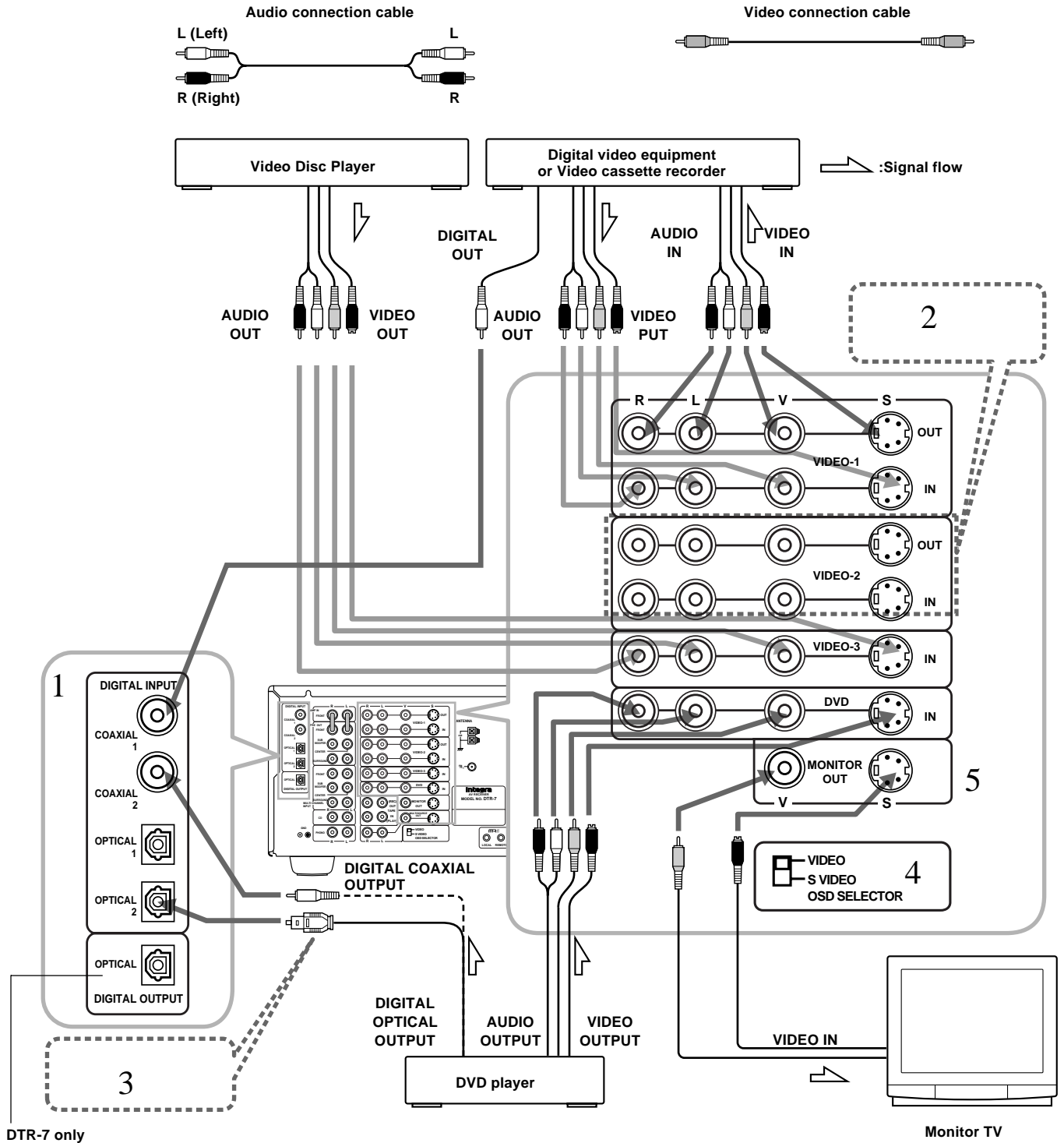



# Video equipment connections

## 1. Digital audio connections

This receiver has a powerful digital signal processor for use with DVD players, DAT decks, and CD players. The digital inputs, COAXIAL 1, 2 and OPTICAL 1, 2 can be assigned to individual input selector buttons, so when an input selector button is pressed, the assigned digital input is used instead of the corresponding analog input. (See page 23,29.)

## 2. Connect your second video cassette deck.

## 3. Connect your DVD player to COAXIAL or OPTICAL, whichever appropriate.

## 4. OSD SELECTOR:

Selects whether to output the OSD (On-Screen Display) information with the Video signals or the S-Video signals. Select "S VIDEO" when the monitor is connected via the S-Video terminal.

## 5. Connecting video equipment through S-video connectors

- The signals input from the S IN jack will be output only to the S OUT jack; the signals input from the V IN jack will be output only to the V OUT jack.
- For information on whether you need to connect either S or V jack or both of them, please refer to the instruction manual that came with your video equipment.

## 6. Connect your video camera or TV game machine to the VIDEO-4 / VIDEO CAM INPUT jacks.

If a monaural video camera is used, connect its audio connection cable to "R(MONO)" audio jack.

### Notes:

- When using a playback-only VCR, connect it to VIDEO 3 or VIDEO 4. If you connect it to VIDEO 1 or VIDEO 2, you need to make only the input connections.
- This receiver can be used only with a monitor TV equipped with a video input or S video jack.
- Interference may be caused between the TV and this receiver. If this interference occurs, place the receiver and the TV as far apart as possible. We do not recommend the use of a common TV/FM antenna (see antenna section).
- Remove the protective cap attached to the DIGITAL INPUT/OUTPUT (OPTICAL) jack before making the connection. When this jack is not used, replace the protective cap.

# Connecting equipment with 5.1-channel output

## Decoder with 5.1-channel output

You may connect the 5.1-channel outputs of an external decoder (such as MPEG decoder and DVD player) to the MULTI CHANNEL INPUTS of this unit.

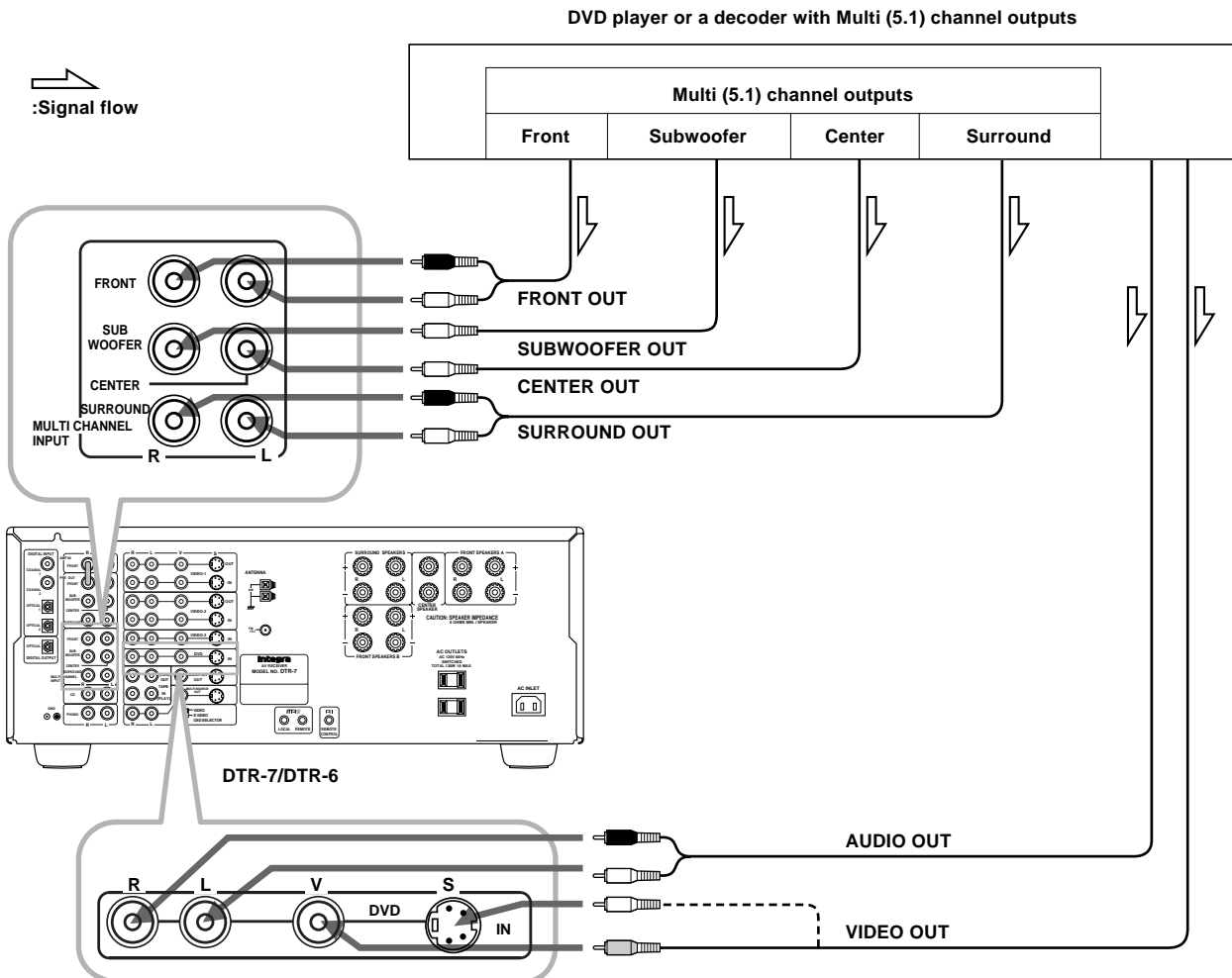

# Connecting speakers

The DTR-7/6 allows you to connect two speaker systems.

Before connecting the speakers, place them correctly by consulting the instruction manuals that came with your speakers.

For surround playback (see "Using the listening modes" on page 34), the configuration and placement of your speakers are very important. For Home THX cinema surround playback, we recommend that you use a THX speaker system that is certified by Lucasfilm Ltd. (such as Onkyo HTS SYSTEM-2).

## Ideal speaker configuration:

- **Right and Left front speakers**
- **Center speaker**  
Produces a rich sound image by serving as a sound source for the Right and Left front speakers and enhancing the sonic movement.
- **Right and Left surround speakers**  
Adds three-dimensional sonic movement and produces environmental sound associated with the background and effect sound for each scene.
- **Subwoofer**  
Produces powerful and heavy bass.

## Minimum speaker configuration for surround sound playback:

- **Right and Left front speakers**
- **Right and Left surround speakers**

The sound recorded for the center speaker and the subwoofer will be properly distributed to the Right and Left front speakers and the Right and Left surround speakers for optimized surround playback.

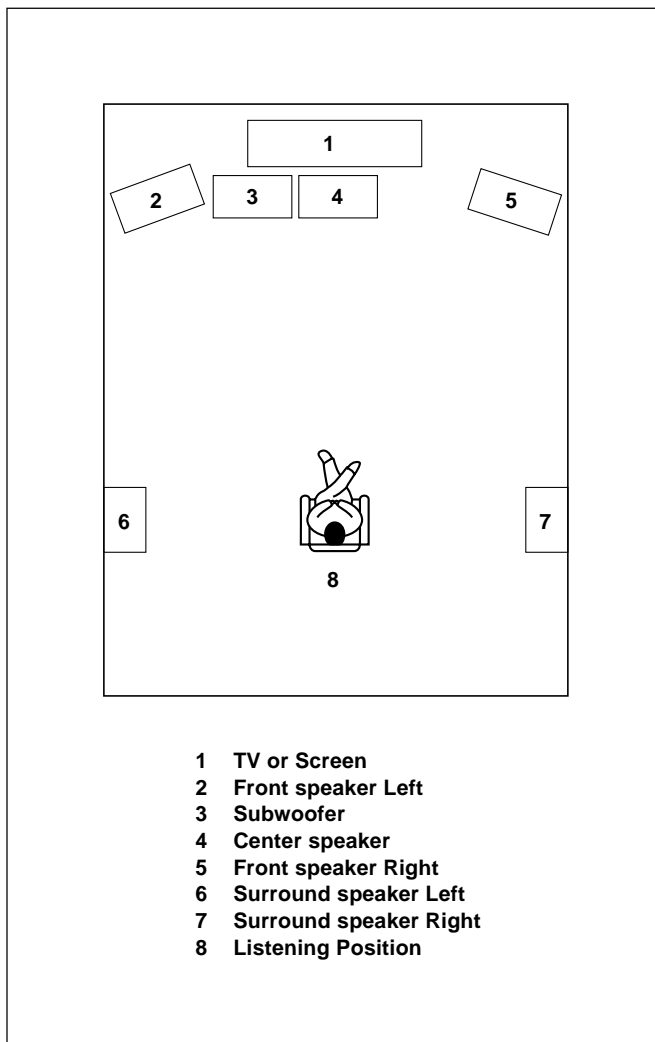

## Speaker placement

Ideal speaker placement varies depending on the size of your room and the wall coverings. Here, only typical example of speaker placement and recommendations are shown.

### Speaker systems

#### Left and Right front speakers and Center speaker

- Place these three speakers at the same height from the floor.
- Place each speaker so that sound is aimed at the audience's ears at the listening position.

#### Left and Right surround speakers

- Place these speakers so that their height is 1 meter higher than that of the audience's ears.

#### Subwoofer





To get the highest bass effect, place a subwoofer. You can place your subwoofer anywhere in your room because the placement affects very little the perceived sound.

# Connecting speakers

- This receiver is designed to produce optimum sound quality when speakers with impedances within the specified ranges are connected. Please check the following information and choose speakers with appropriate impedances for the connections.

**FRONT SPEAKERS:** A or B: 6 ohms min./speaker  
**SURROUND SPEAKERS:** 6 ohms min./speaker  
**CENTER SPEAKER:** 6 ohms min.

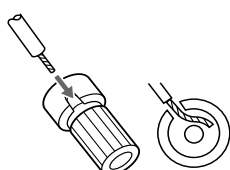
### Connecting the speaker cable

- Twist wire ends very tight.
 
- Unscrew.
 
- Insert wire.
 
- Screw.
 

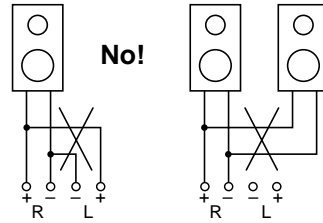

- When you use only one speaker or wish to listen to monaural (mono) sound, a single speaker should never be connected in parallel to both the right and left channel terminals simultaneously.

**Note:**  
 To prevent damage to circuitry, never short-circuit the positive (+) and negative (-) speaker wire.



Front Speaker A  
R ch.

Front Speaker A  
L ch.

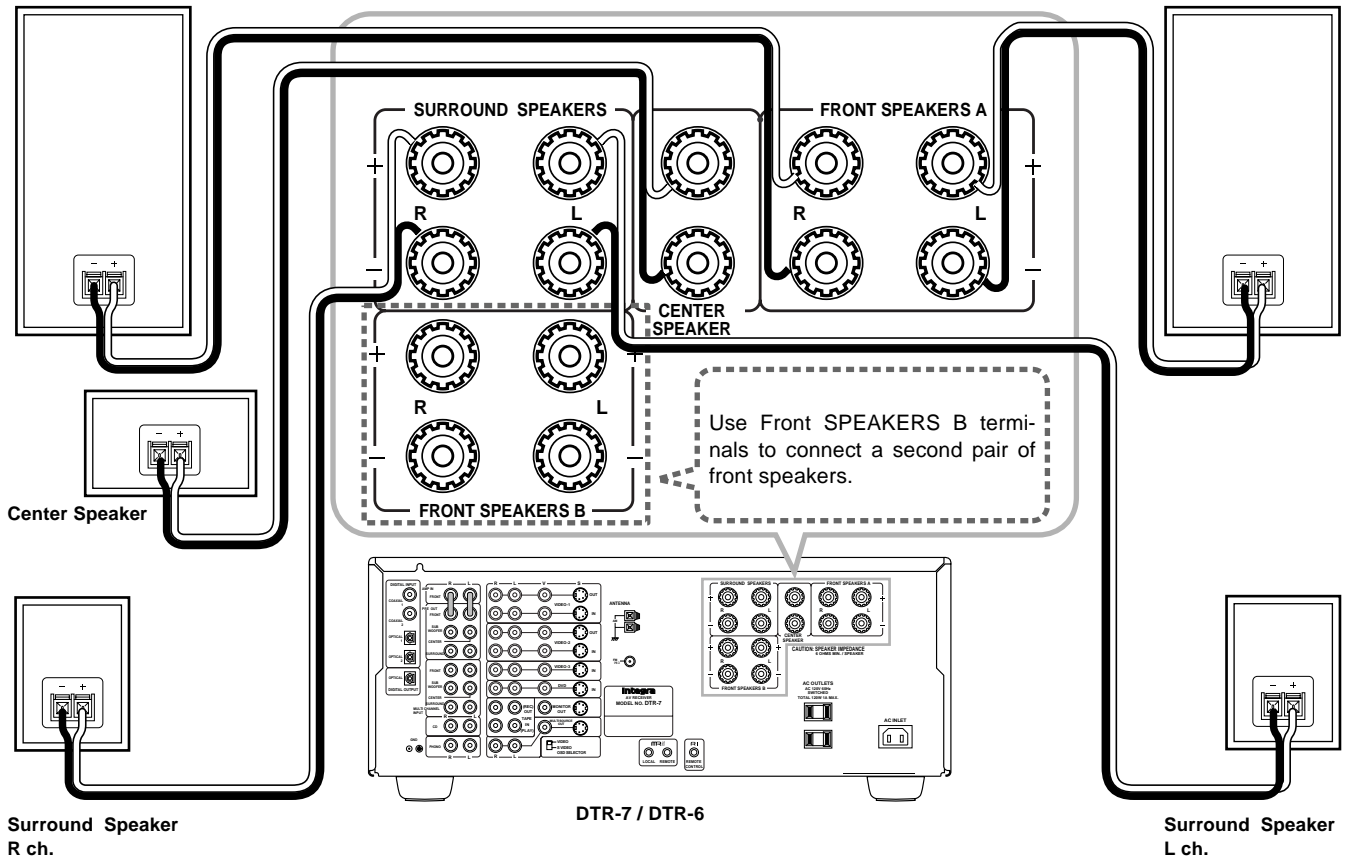

# Connecting speakers

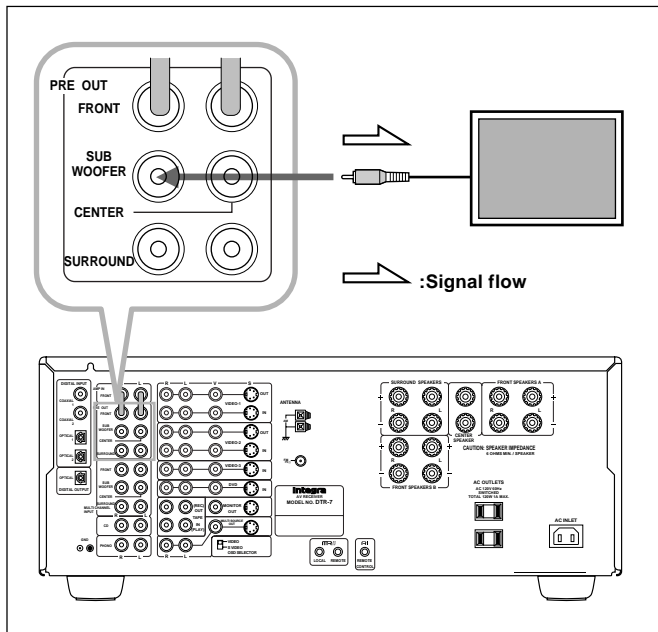

## Connecting a subwoofer

Use the PRE OUT SUBWOOFER jack to connect a subwoofer with a built-in power amplifier. If your subwoofer does not have a built-in amplifier, connect an amplifier to the PRE OUT SUBWOOFER jack and the subwoofer to the amplifier.

# Connecting power amplifiers

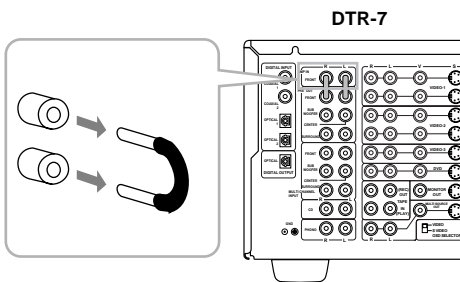

## Connecting power amplifiers

Using auxiliary power amplifiers allows you to listen at louder volumes than with the DTR-7/DTR-6 alone. If power amplifiers are used, connect each speaker to the corresponding power amplifier. When using speakers connected through external power amplifiers, turn OFF the SPEAKERS A.

### Notes:

- Keep the jumper plugs so that you will not lose them.
- When the connectors are not in use, replace the jumper plugs.

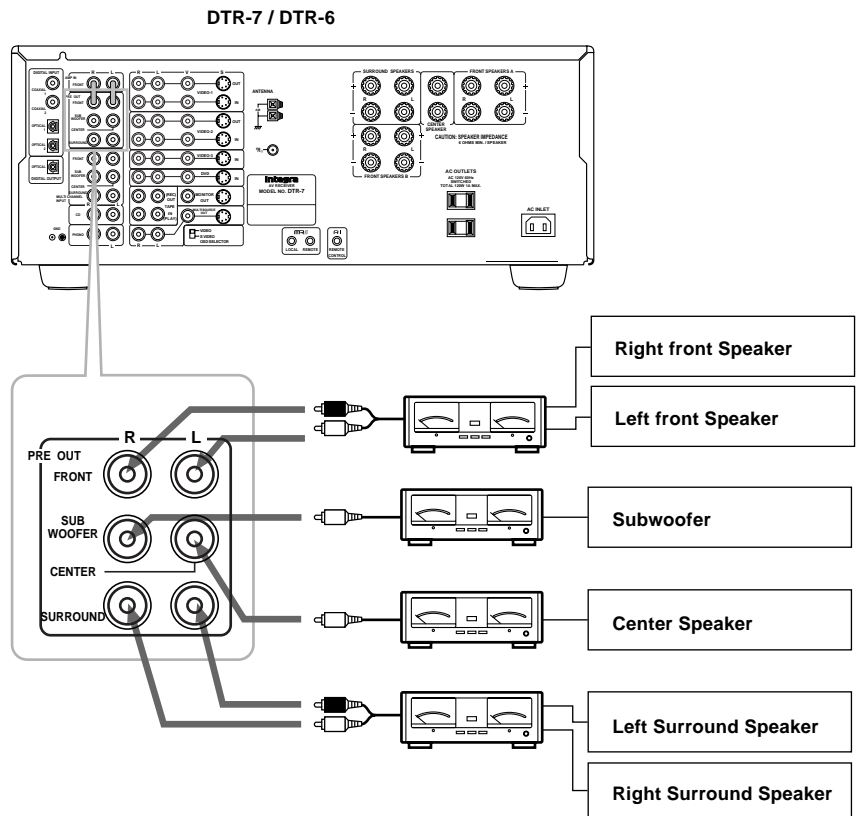

# Connecting an equalizer (DTR-7)

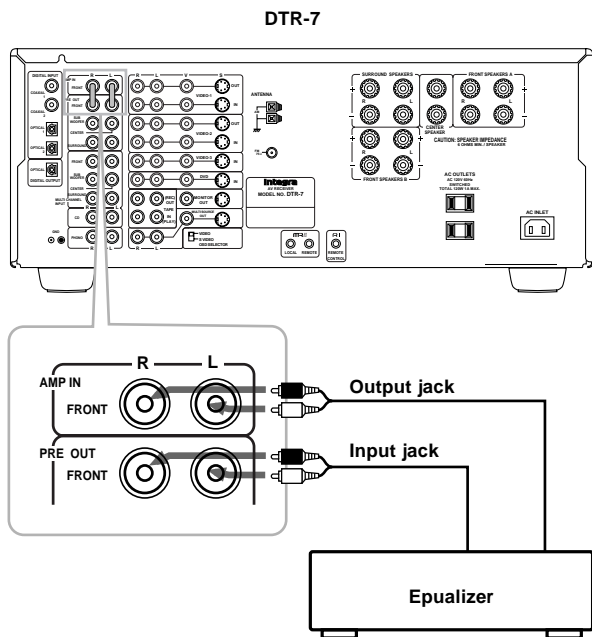

The AMP IN and the PRE OUT FRONT connectors are attached with jumper plugs. When connecting an equalizer, remove these jumper plugs before connecting the audio connection cables.

1. **Remove the jumper plugs.**  
See "Connecting power amplifiers."
2. **Connect an equalizer.**

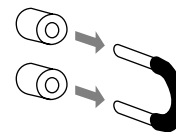

# Connecting the power

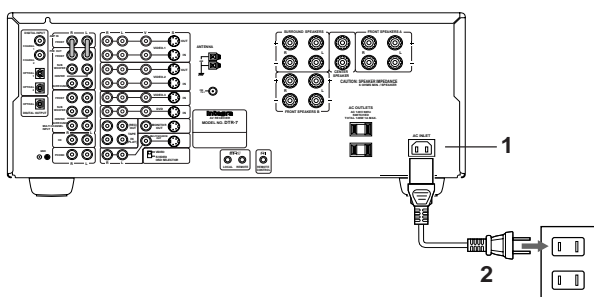

## Connecting a power cable

1. **Connect the outlet plug on the included power cable to the AC INLET on the DTR-7/ DTR-6.**
2. **Plug-in the other end of the cable to a wall AC outlet.**

### Notes:

- Do not use any power cable other than the included cable. The included cable is designed for use only with the DTR-7/ DTR-6. Do not use it for any other device.
- Do not connect or disconnect the outlet plug from the DTR-7/DTR-6 while the other end is plugged into the wall AC outlet.

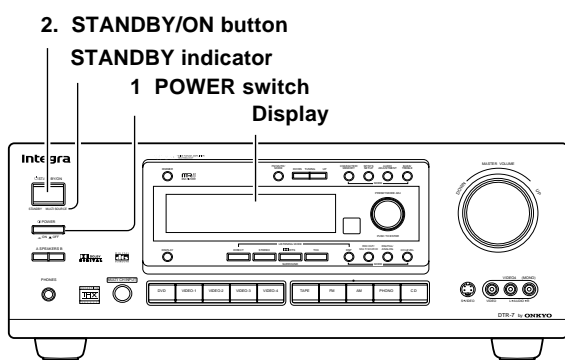

## Connecting the power

- Before you turn on the receiver, confirm that all connections have been made properly.
- Turning on this receiver's power may cause a momentary power surge, which might interfere with other electrical equipment, such as computers. If this happens, use a wall outlet on a different circuit.

1. **Press the POWER switch to set the receiver to Standby mode.**

The STANDBY indicator will light up.

2. **Press the STANDBY/ON button to turn on the receiver. The display will light up and the STANDBY indicator will be turned off.**

If you press the STANDBY/ON button, the receiver returns to Standby mode.

### Turning the power on from the remote controller:

1. **Press the MODE AUDIO button.**
2. **Press the POWER ON button to turn on the power to the receiver, or press the POWER STNBY button to set the receiver in standby mode.**

- You cannot use the remote controller if the POWER switch on the receiver is set to OFF.
- Set the volume level to minimum before you turn off the power to the receiver.

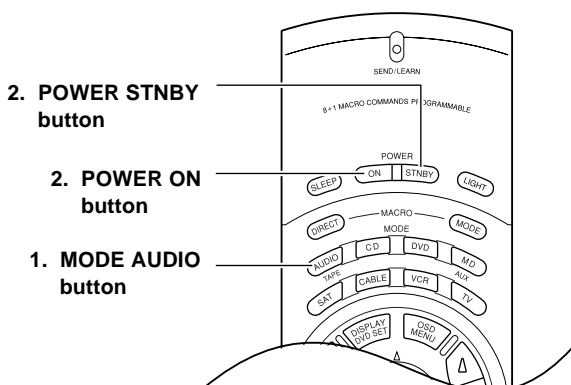

# Making antenna connections

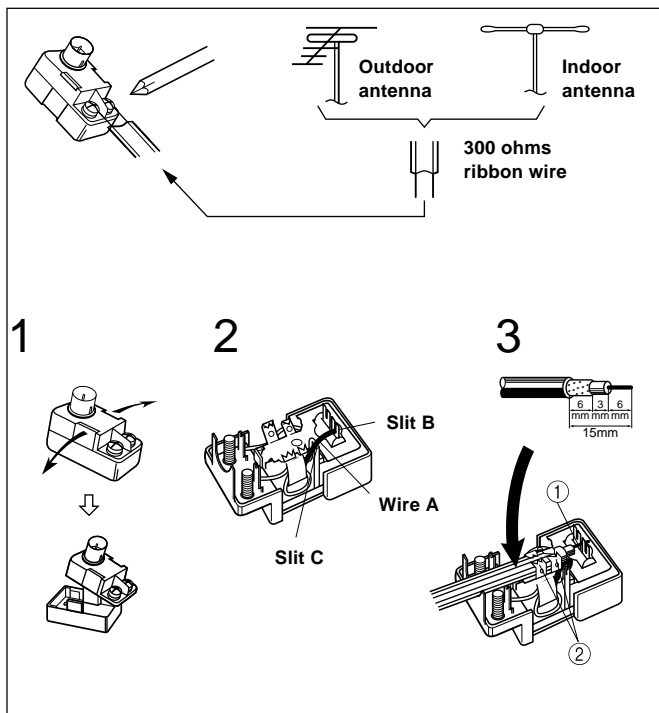

**Connecting the antenna cable to the 75/300 ohm antenna adapter. (The antenna adapter must be separately ordered.)**

**Connecting the 300 ohm ribbon wire:**  
Loosen the screws and wrap the wire around these screws. Then tighten the screws with a screwdriver.

**Connecting the coaxial cable:**

1. With your fingernail or a small screwdriver, press the stoppers outward and remove the cover.
2. Remove the transformer wire A from slit B and insert it into slit C.
3. Prepare the coaxial cable as shown in the diagram.  
Connect the 75/300 ohm antenna adapter to the coaxial cable.
  - 1 Insert the end of the cable.
  - 2 Clamp it in place with pliers.
4. Re-install the cover.

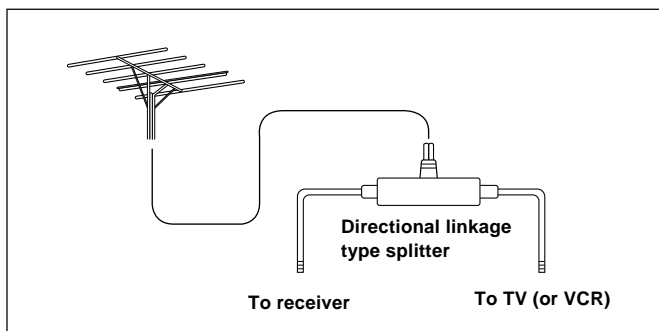

## Directional linkage

Do not use the same antenna for both FM and TV (or VCR) reception since the FM and TV (or VCR) signals can interfere with each other. If you must use a common FM/TV (or VCR) antenna, use a directional linkage type splitter.

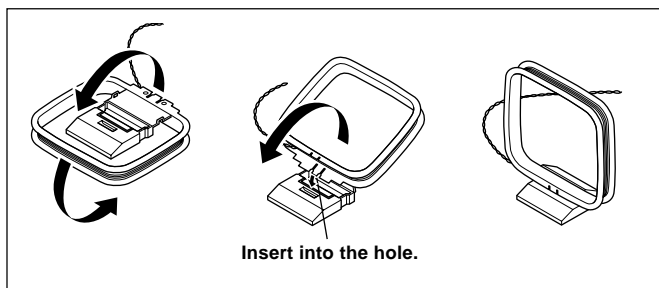

## Assembling the AM loop antenna

Assemble the loop antenna as shown in the illustration.

- Refer to the next page for details on connecting the AM loop antenna.

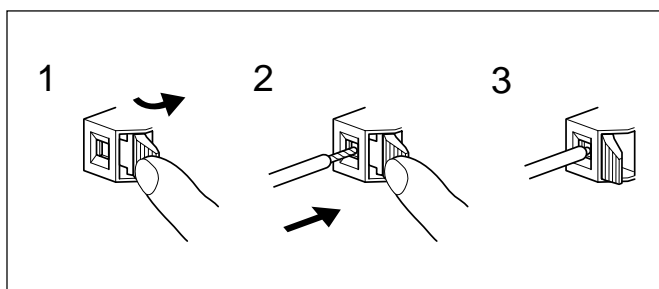

## Connecting the antenna cable

1. Press down the lever.
2. Insert the wire into the hole.
3. Release the lever to replace it.

## Making antenna connections

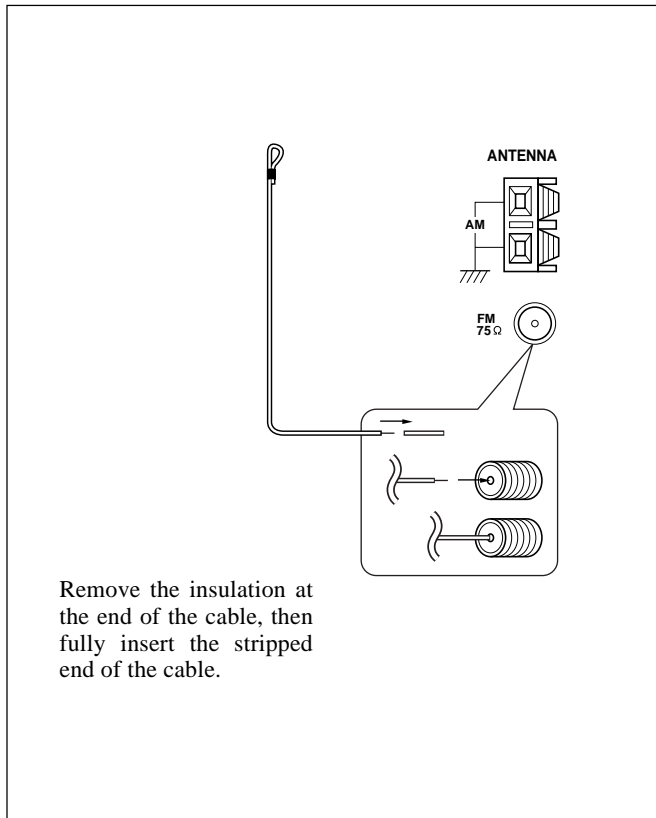

### Connecting the included antennas

#### Connecting the FM indoor antenna:

The FM indoor antenna is for indoor use only. Extend the antenna and move it in various directions until the clearest signal is received. Fix it with push pins or similar implements in the position that will cause the least amount of distortion.

If the reception is not very clear with the attached FM indoor antenna, the use of an outdoor antenna is recommended.

#### Connecting the AM loop antenna:

The AM loop antenna is for indoor use only. Set it in the direction and position where you receive the clearest sound. Put it as far away as possible from the unit, TVs, speaker cables, and power cords.

When reception is not satisfactory with the attached AM loop antenna alone, connection of an outdoor antenna is recommended.

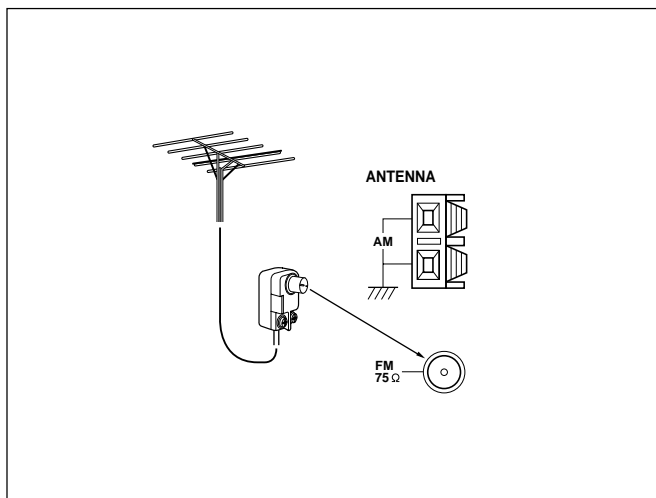

### Connecting an FM outdoor antenna

Please make sure that you follow the considerations below regarding the location.

Keep the antenna away from noise sources (neon signs, busy roads, etc.).

It is dangerous to put the antenna close to power lines. Keep it well away from power lines, transformers, etc.

- To avoid the risk of lightning and electrical shock, grounding is necessary. Follow item 19 of the "Important Safeguards" on page 2 when you install the outdoor antenna.

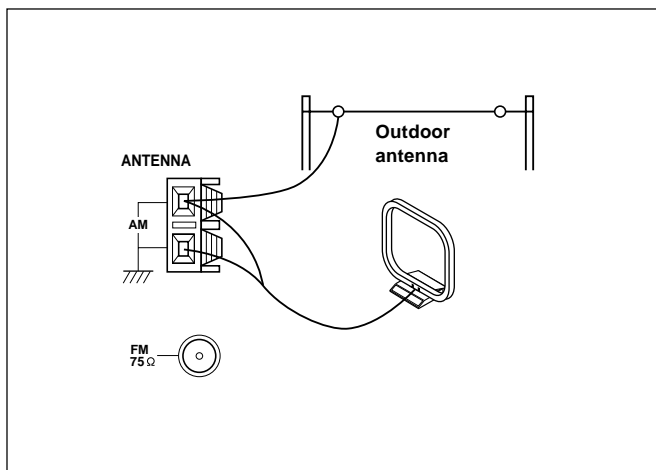

### Connecting an AM outdoor antenna

The outdoor antenna will be more effective if it is stretched horizontally above a window or outside.

- Do not remove the AM loop antenna.
- To avoid the risk of lightning and electrical shock, grounding is necessary. Follow item 19 of the "Important Safeguards" on page 2 when you install the outdoor antenna.



# Using the on-screen display

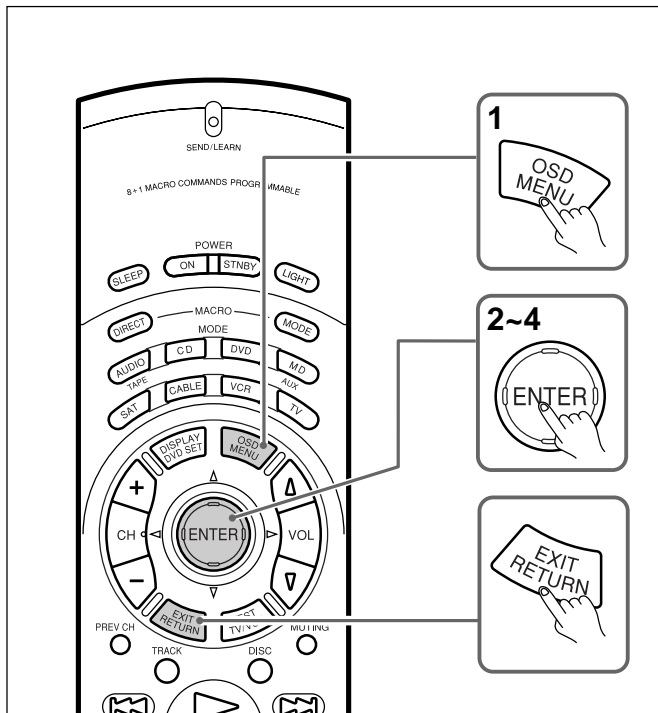

Using the OSD (on-screen display) function lets you display each screen on your TV so that you can perform various settings using only the remote controller.

## How to use the on-screen display

1. **Press the OSD MENU button.**  
The on-screen display appears.
2. **Press the upper or lower edge of the ENTER/Cursor button to select the item.**  
The items you can select on each screen are shown on the next page.
3. **Press the right edge of the ENTER/Cursor button to display the setting screen.**  
On each screen, you can press the upper or lower edge of the ENTER/Cursor button to select an item and then press the right or left edge of the button to change the setting.  
If the item has an additional screen, you can press the right edge of the button to change to that screen.
4. **Press the center of the ENTER/Cursor button.**

Use either of the following methods to turn off the on-screen display.

- Press the center of the ENTER/Cursor button.  
By pressing this button, you can follow in reverse the sequence in which you have displayed each setting screen. Finally, the on-screen display disappears.
- Press the EXIT button.  
The on-screen display disappears immediately.

3

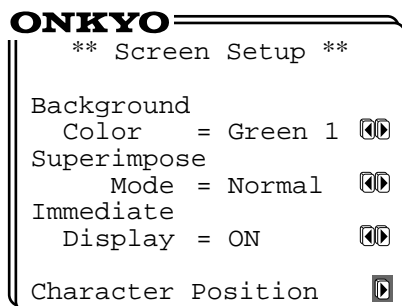

## Screen Setup

Use the on-screen display to set the background color, the superimpose mode, etc.

1. **Press the OSD MENU button.**
2. **Select "Screen Setup" and press the right edge of the ENTER/Cursor button.**
3. **Press the upper or lower edge of the ENTER/Cursor button to select each item and then press the right or left edge of the button to set a parameter.**

**Background Color :** Select the desired color from BLUE-1, BLUE-2, GREEN-1, GREEN-2, MAGENTA, RED-1, and RED-2.

**Superimpose Mode :** Select one of the following:

**OFF :** The on-screen display appears on the selected background color.

**Normal :** The on-screen display is superimposed on images when video signals are input and shown on the selected background color when no video signal is input.

**Black :** The on-screen display appears on black screen.

**Immediate Display :** Select either "ON" or "OFF." When set to "ON," the screen will show for 3 seconds the result (or process) of the operation every time you operate the unit. For example, the volume level indicator appears on the screen when you increase the sound volume.

**Character Position :** Using the ENTER/Cursor button, move the on-screen display to the lower left, upper left, upper right, or lower right of the TV screen.

4. **Press the center of the ENTER/Cursor button, or press the EXIT button.**

# Using the on-screen display

## OSD screens

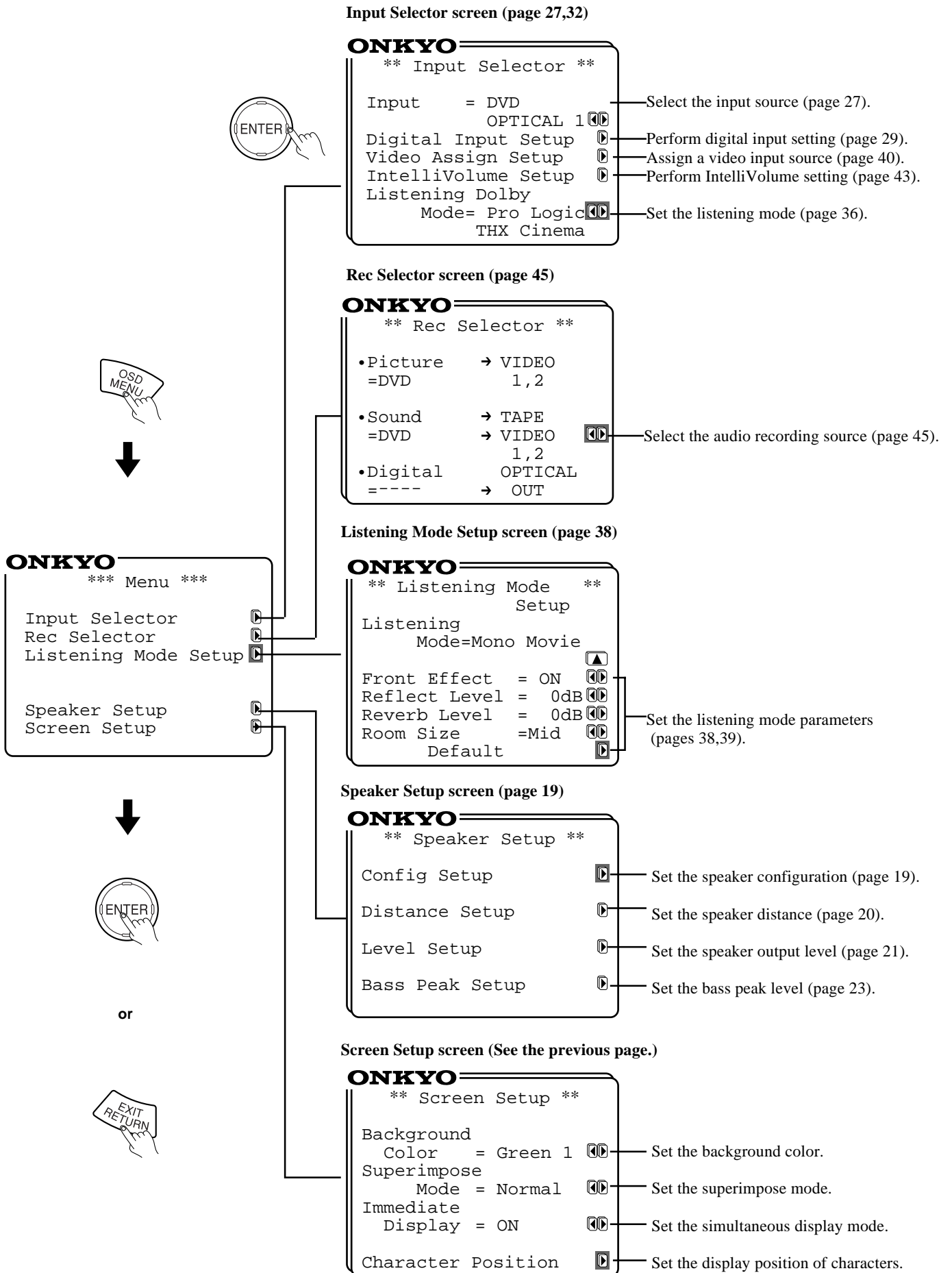

# Setting the speaker configuration

Perform this setup before using the unit.

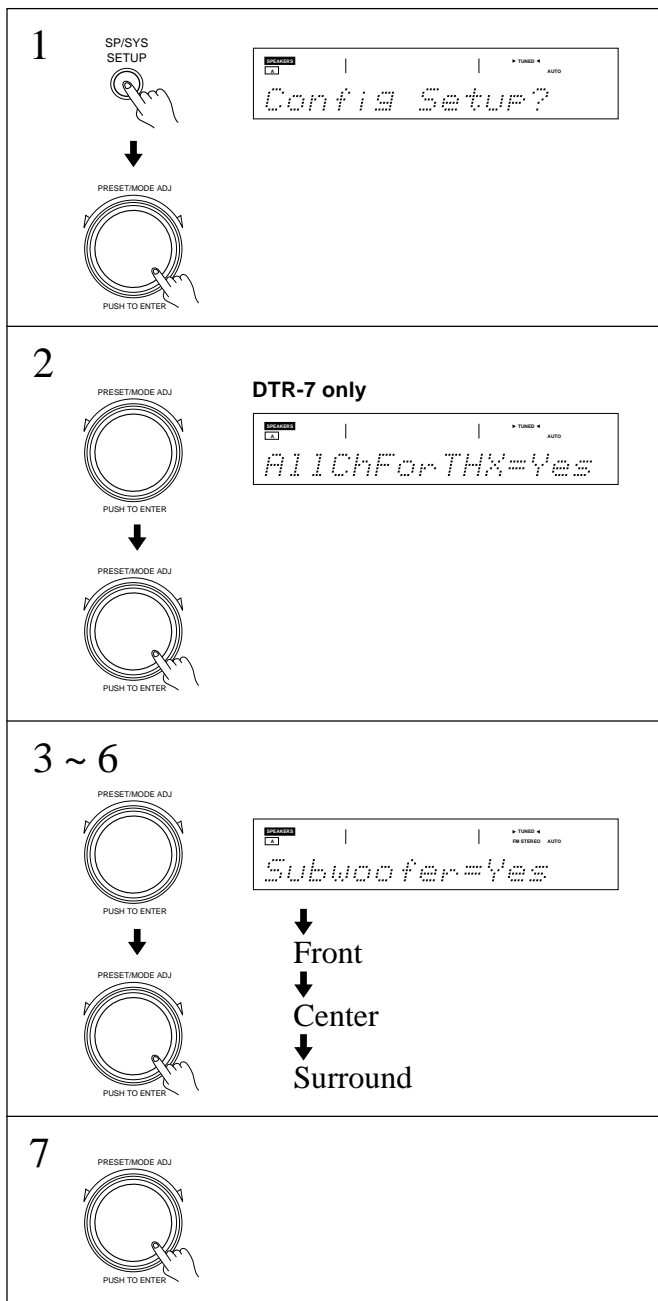
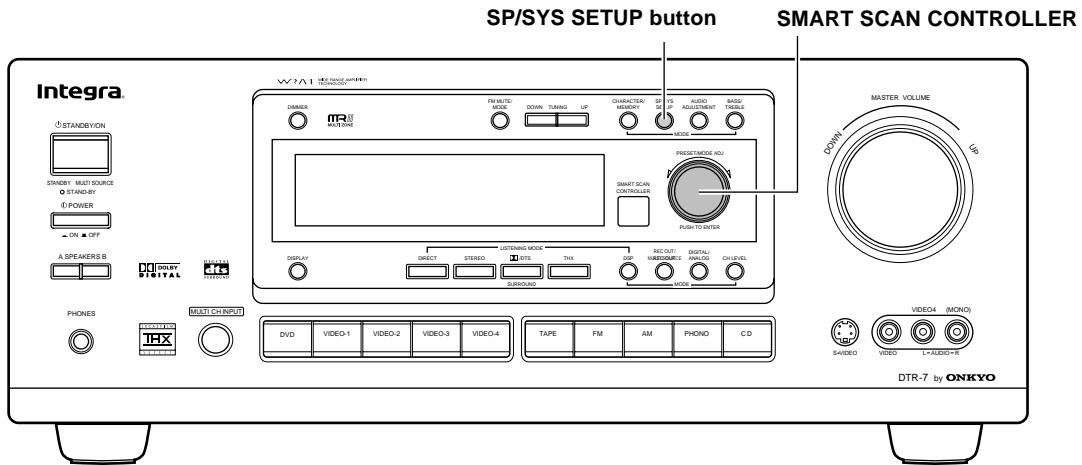

## Setting the speaker configuration parameters

Using the SMART SCAN CONTROLLER, you can easily set the speaker configuration. Turn it to select the parameter and press it to go to the next item.

- Press the SP/SYS SETUP button.**  
"Config Setup?" appears. Then Press the SMART SCAN CONTROLLER.
- For the DTR-6, go to the next step.**  
**For the DTR-7, "All Ch For THX" appears.**  
**Set "Yes" or "No."**  
**Yes:** Your system is a THX speaker system.  
(The following steps are unnecessary.)  
**No:** Your system is a non-THX speaker system.  
Press the SMART SCAN CONTROLLER.
- Set whether or not a subwoofer is connected.**  
**Yes:** A subwoofer is connected.  
**No:** A subwoofer is NOT connected.  
Press the SMART SCAN CONTROLLER.
- Select the size of your front speakers.**  
**Large:** Large front speakers are used.  
**Small:** Small front speakers are used.  
Press the SMART SCAN CONTROLLER.
- Select the size of your center speaker.**  
**Large:** A large center speaker is used.  
**Small:** A small center speaker is used.  
**None:** A center speaker is NOT used.  
Press the SMART SCAN CONTROLLER.
- Select the size of your surround speakers.**  
**Large:** Large surround speakers are used.  
**Small:** Small surround speakers are used.  
**None:** Surround speakers are NOT used.  
Press the SMART SCAN CONTROLLER.
- Press the SMART SCAN CONTROLLER.**  
This completes the speaker configuration setup.

# Setting the speaker configuration

3

**ONKYO**

\*\* Speaker Setup \*\*

Config Setup ▶

Distance Setup ▶

Level Setup ▶

Bass Peak Setup ▶

4

**ONKYO**

\* Config Setup \*

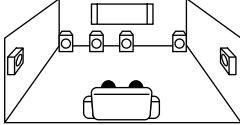

All Channel For THX Speakers =No ▶▶

5

**ONKYO**

\* Config Setup \*

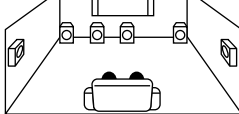

Subwoofer =Yes ▶▶

Front =Small ▶▶

Center =Small ▶▶

Surround =Small ▶▶

- **Using the on-screen display**
- 1. Press the OSD MENU button.
- 2. Select "Speaker Setup" and then press the right edge of the ENTER/Cursor button.
- 3. Select "Config Setup" and then press the right edge of the ENTER/Cursor button.
- 4. **For the DTR-6, go to the next step.**  
**For the DTR-7, the display shows "All Channel For THX Speakers."**  
 Select "Yes" and then press the center of the ENTER/Cursor button. This sets all the connected speakers to THX speakers. (The following steps are unnecessary.)  
 Select "No" and then press the center of the ENTER/Cursor button to go to the next step.
- 5. **Press the upper or lower edge of the ENTER/Cursor button to set each item and then press the right or left edge of the button to set a parameter**
  - Subwoofer: Set whether or not a subwoofer is connected.**  
 Yes: A subwoofer is connected.  
 No: A subwoofer is NOT connected.
  - Front : Select the size of your front speakers.**  
 Large: Large front speakers are used.  
 Small: Small front speakers are used.
  - Center : Select the size of your center speaker.**  
 Large: A large center speaker is used.  
 Small: A small center speaker is used.  
 None: A center speaker is NOT used.
  - Surround : Select the size of your surround speakers.**  
 Large: Large surround speakers are used.  
 Small: Small surround speakers are used.  
 None: Surround speakers are NOT used.
- 6. Press the center of the ENTER/Cursor button, or press the EXIT button, to exit the setup mode.

# Setting the speaker distance

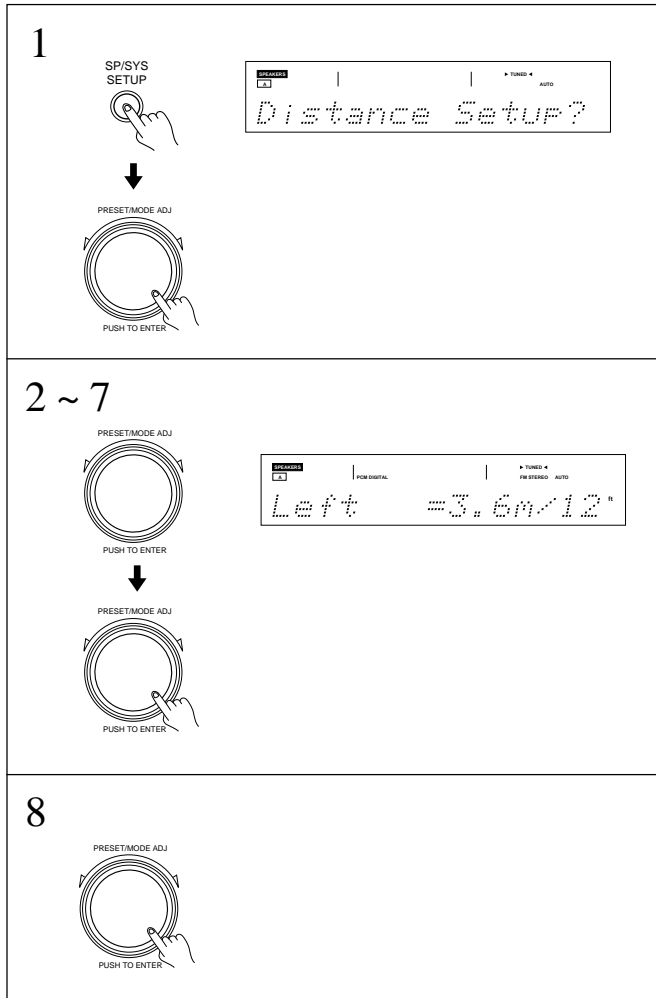

## Setting the distance from each speaker to the listening position (Loudspeaker Position Time Synchronization\*)

Select a value that is closest to the actual distance between each speaker and the listening position.

Using the SMART SCAN CONTROLLER, you can easily set the speaker configuration. Turn it to select the setting and press it to go to the next item.

For each speaker, you can set a distance of 0.3 meter to 9.0 meters (or 1 foot to 30 feet) in increments of 30 cm (1 foot).

1. **Press the SP/SYS SETUP button repeatedly until "Distance Setup ?" appears.**  
Press the SMART SCAN CONTROLLER.
2. **"Left=" appears. Set the distance from the left front speaker.**  
Press the SMART SCAN CONTROLLER.
3. **"Center=" appears. Set the distance from the center speaker.**  
Press the SMART SCAN CONTROLLER.
4. **"Right=" appears. Set the distance from the Right front speaker.**  
Press the SMART SCAN CONTROLLER.
5. **"R-Sur=" appears. Set the distance from the Right surround speaker.**  
Press the SMART SCAN CONTROLLER.
6. **"L-Sur=" appears. Set the distance from the left surround speaker.**  
Press the SMART SCAN CONTROLLER.
7. **"SW=" appears. Set the distance from the subwoofer.**
8. **Press the SMART SCAN CONTROLLER.**  
The speaker distance setup has been completed.

\* Loudspeaker Position Time Synchronization is a registered trademark of Lucasfilm LTD.

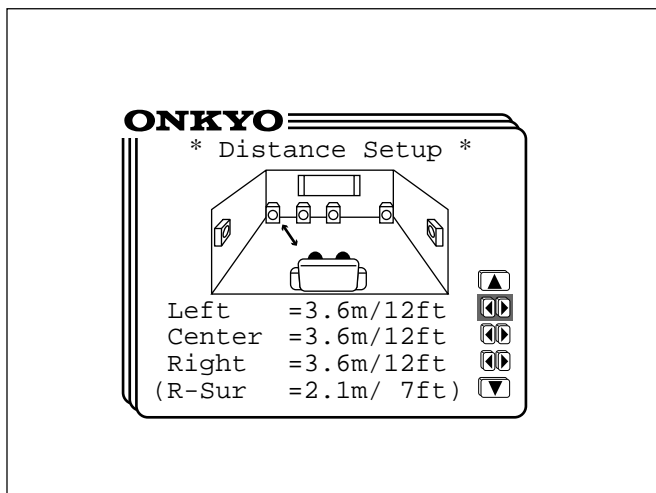

### • Using the on-screen display

1. **Press the OSD MENU button.**
2. **Select "Speaker Setup" and then press the right edge of the ENTER/Cursor button.**
3. **Select "Distance Setup" and then press the right edge of the ENTER/Cursor button.**

You can now set the distance from each speaker.

(When the cursor is on "Right," you can press the lower edge of the ENTER/Cursor button to display additional items.)

Select a value that is closest to the actual distance. For each speaker, you can set a distance of 0.3 meter to 9.0 meters (or 1 foot to 30 feet) in increments of 30 cm (1 foot).

- Left:** Left front speaker
- Center:** Center speaker
- Right:** Right front speaker
- R-Sur:** Right surround speaker
- L-Sur:** Left surround speaker
- Subwoofer:** Subwoofer

4. **Press the center of the ENTER/Cursor button, or press the EXIT button, to exit the setup mode.**

# Setting the speaker Level

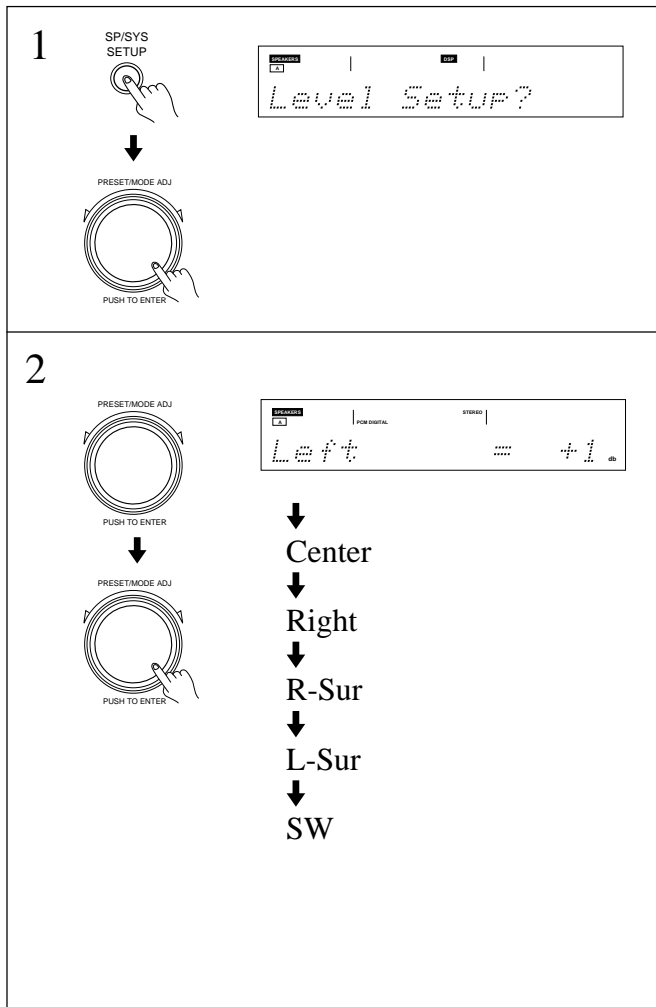

## Using the test tone to adjust the speaker output levels

- Press the SP/SYS SETUP button repeatedly until "Level Setup?" appears. Press the SMART SCAN CONTROLLER. The display shows "Left."
- Rotate clockwise or counterclockwise the SMART SCAN CONTROLLER to adjust the speaker output level. You can adjust the output level of each speaker in the range of 12 to +12 dB, except for the subwoofer whose adjustment range is -30 to +10 dB. Press the SMART SCAN CONTROLLER. You hear a test tone (pink noise) from the left front speaker. Each time you press the SMART SCAN CONTROLLER, the speaker that produces a test tone changes as below. Set the output level of each speaker by rotating the SMART SCAN CONTROLLER so that you can hear the same level of test tone at the listening position.  
Left (Left front) → Center (Center) → Right (Right front) → R-Sur (Right surround) → L-Sur (Left surround) → Subwoofer (Subwoofer) → Left

### Notes:

- In order to correctly set the output levels, use a hand-held Sound Pressure Level meter (SPL), set to C-Weighting and Slow averaging. A Radio Shack® SPL meter (catalogue number 330-2055) or equivalent can be used. Using the internal channel noise generators, set each channel so that you read 75 dB SPL from each channel.
- SPEAKER B, when selected, will be deselected automatically as soon as the test tone starts sounding. The Test Tone function is not available when the headphones are connected or when MULTI CH INPUT is selected.
- The test tone will not be output from the speaker that has been set to "No" in the configuration setup explained on the page 18,19.
- If the speaker level is set to +1dB or higher, the maximum level indicated on the display will change if you raise the volume level.

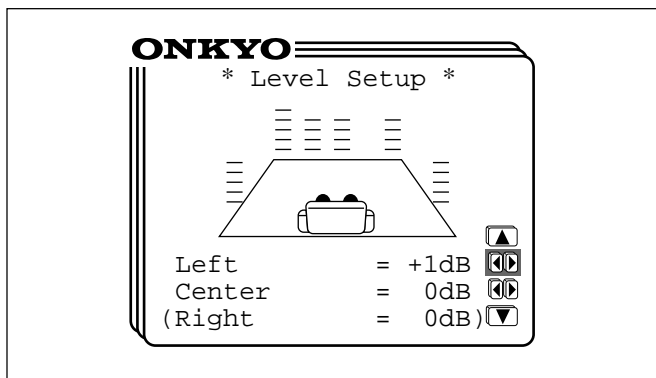

## Using the on-screen display

- Press the OSD MENU button.
- Select "Speaker Setup" and then press the right edge of the ENTER/Cursor button.
- Select "Level Setup" and then press the right edge of the ENTER/Cursor button.

The Level Setup screen appears and a test tone (pink noise) is output from the left front speaker. You can change the speaker that outputs the test tone in the following sequence. (When the cursor is on "Center," you can press the lower edge of the ENTER/Cursor button to display additional items.)

Left (Left front) → Center (Center) → Right (Right front) → R-Sur (Right surround) → L-Sur (Left surround) → Subwoofer (Subwoofer) → Left.

- Set the output level of each speaker so that you can hear the same level of test tone in the listening position. You can adjust the output level of each speaker in the range of -12 to +12 dB, except for the subwoofer whose adjustment range is -30 to +10 dB.
- Press the center of the ENTER/Cursor button, or press the EXIT button, to exit the setup mode.

## Using Test button on the remote controller

- Press the MODE AUDIO button.
- Press the TEST button. Left front speaker produces the test tone (pink noise).
- To adjust the level of each speaker, press the CH SEL, button to select a speaker and press the LEVEL +/- buttons to raise or lower the level.
- Press the TEST button to complete adjustment.

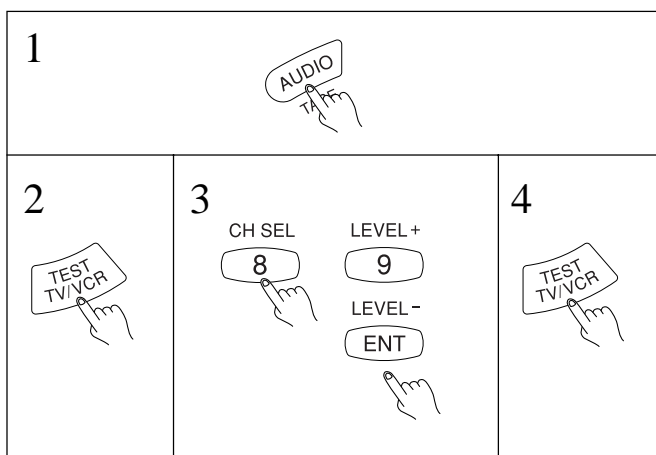

# Setting the Speaker level

**1**

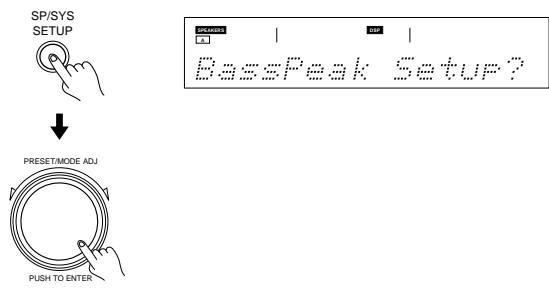

SP/SYS SETUP

PRESET/MODE ADJ

PUSH TO ENTER

BassPeak Setup?

**2**

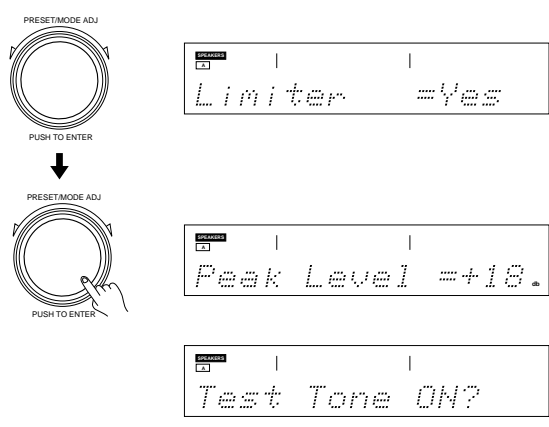

PRESET/MODE ADJ

PUSH TO ENTER

PRESET/MODE ADJ

PUSH TO ENTER

PRESET/MODE ADJ

PUSH TO ENTER

Limiter =Yes

Peak Level =+18.

Test Tone ON?

**3**



PRESET/MODE ADJ

PUSH TO ENTER

Turn SSC Up

**4**

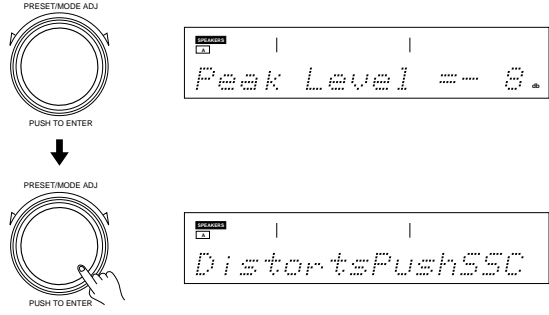

PRESET/MODE ADJ

PUSH TO ENTER

PRESET/MODE ADJ

PUSH TO ENTER

Peak Level =- 8.

DistortsPushSSC

## Setting the bass peak level (Bass Peak Level Manager\* DTR-7 only)

To prevent damage to your subwoofer, you can set the bass peak level the subwoofer can reproduce.

If your system does not include any subwoofer, this will set the bass peak level your Front speakers can reproduce.

**1. Press the SP/SYS SETUP button repeatedly until “Bass Peak Setup?” appears. Then Press the SMART SCAN CONTROLLER.**

“Limiter =” appears and you are now in the bass peak level setting mode.

**2. Rotate the SMART SCAN CONTROLLER to select “Yes” or “No.”**

If you select “Yes” and then press the SMART SCAN CONTROLLER, the display will show the current peak level followed by “Test Tone ON?”

**3. Press the SMART SCAN CONTROLLER.**

The test tone is output and “Turn SSC Up” appears.

**4. Gently rotate the SMART SCAN CONTROLLER clockwise and, just before sound is distorted, press the SMART SCAN CONTROLLER.**

If you do not press the SMART SCAN CONTROLLER, “Distorts Push SSC” appears.

### Note:

- Allowing the speakers to produce distorted sound for a long time may cause damage to the speakers.
- To disable the bass peak level limiter, select “No” in step 2.

\* Bass Peak Level Manager is a registered trademark of Lucasfilm LTD.



## Setting the Speaker level

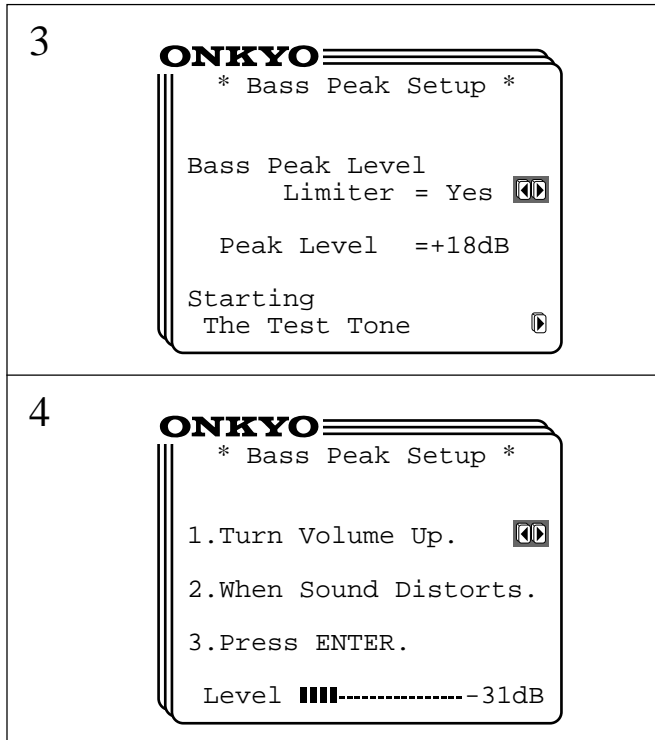

### • Using the on-screen display

1. Press the OSD MENU button.
2. Select "Speaker Setup" and then press the right edge of the ENTER/Cursor button.
3. Select "Bass Peak Setup" and then press the right edge of the ENTER/Cursor button.

The "Bass Peak Setup" screen appears.

#### Bass Peak Level Limiter :

Enables (Yes) / Disables (No) the bass peak limiter.

The Peak Level indicates the bass peak level when the limiter is set to Yes.

4. Select "Starting The Test Tone" and then press the right edge of the ENTER/Cursor button.

This generates a test signal and automatically sets the unit's MASTER VOLUME control knob to -27 dB.

You can now press the right and left edges of the ENTER/Cursor button to adjust the peak level in units of 1 dB.

5. Press the ENTER/Cursor button just before the sound is distorted.

The bass peak level is stored and the Speaker Setup screen is displayed again.

## Playing a digital source (Digital Input Setup)

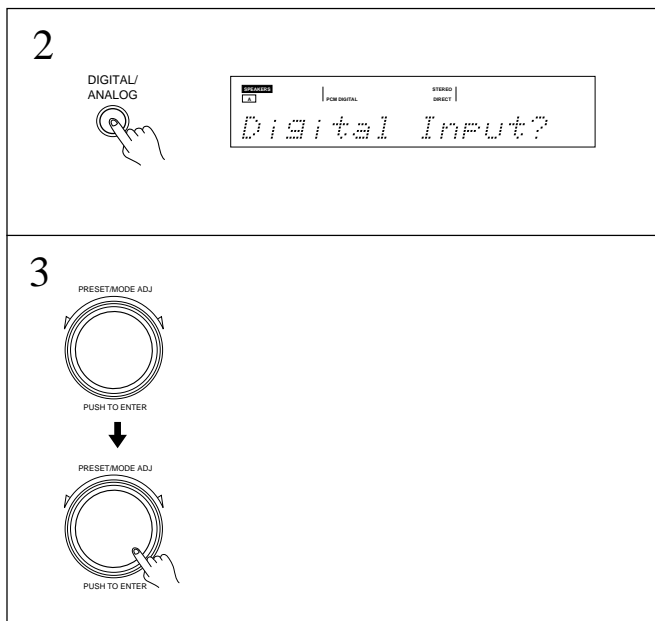

### Digital input setup

Each of the DVD, CD, VIDEO 1-3, and TAPE input channels can be set so that it accepts analog or digital audio input. The default setting is below. Change the setting according to the connection.

DVD: OPT2  
 VIDEO1: COAX1  
 VIDEO2: ----  
 VIDEO3: COAX2  
 TAPE: ----  
 CD: OPT1

Assume that you have connected a DVD player to the COAXIAL 1 connector.

1. Press the DVD input selector button.
2. Press the DIGITAL/ANALOG button until "Digital Input?" appears.

3. Press the SMART SCAN CONTROLLER.

The digital input setup mode has been set.

By rotating the SMART SCAN CONTROLLER, select the digital audio input connector "COAX 1," from among "OPT 1," "OPT 2," "COAX 1," "COAX 2" and "----." Selecting "----" sets analog audio input.

4. Press the SMART SCAN CONTROLLER.

This completes the digital input setup.

To select an input source using the on-screen display, follow steps 1 through 3 described on page 29.

# Presetting FM/AM radio stations

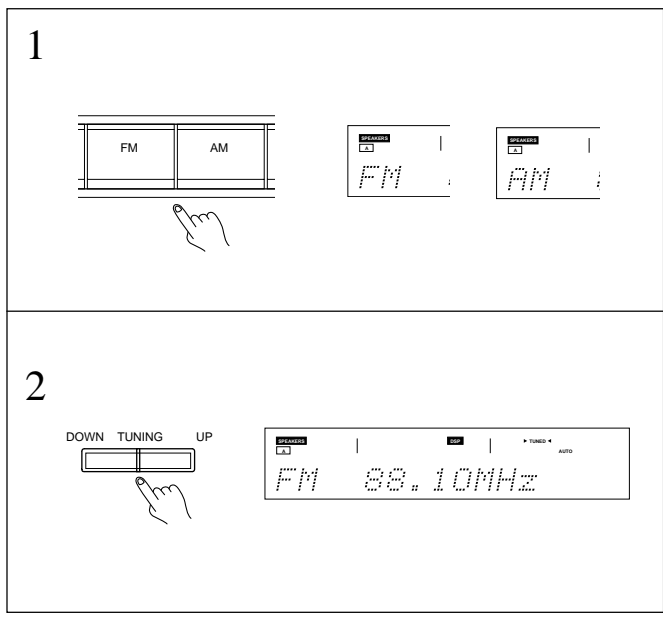
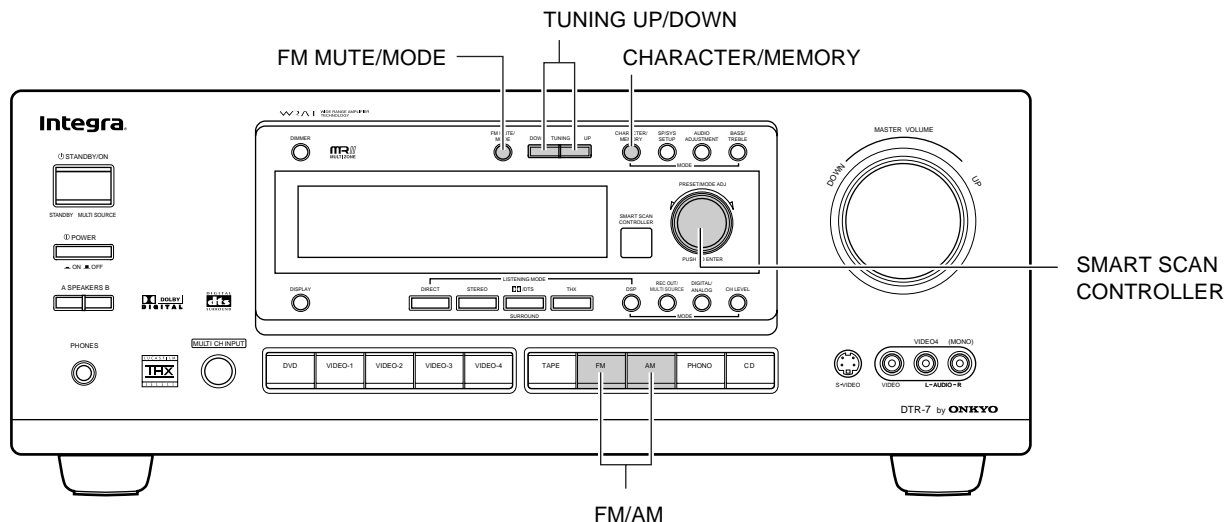

## Tuning in a radio station

1. Press the FM or AM button.
2. Use the TUNING UP/DOWN buttons to change the frequency.
  - UP.....the frequency increases.
  - DOWN..... the frequency decreases.
  - The frequency changes in 50 kHz steps in FM and 10 kHz in AM each time you press the TUNING UP/DOWN button.
  - In FM, if this button is held continuously for more than 0.5 seconds, the frequencies are scanned automatically (FM auto tuning mode).  
When a broadcast is received, scanning stops.

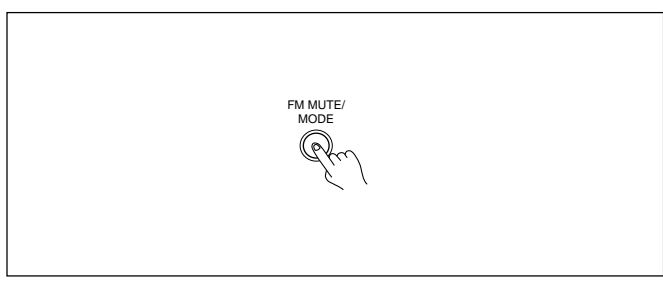

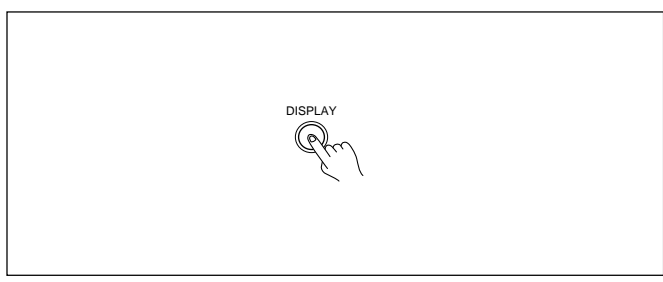

**Listening to a stereo radio station (FM mode)**  
 When you tune in a stereo FM station, the FM STEREO indicator lights up if the signal is sufficiently strong. If the signal is weak, it may be impossible to tune in to the desired station. In this case, tune in as follows. Press the FM MUTE/MODE button. The AUTO indicator turns off. At this time, the station will be in mono and interstation noise will be heard. Select the station to which you want to listen.



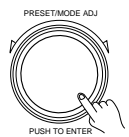
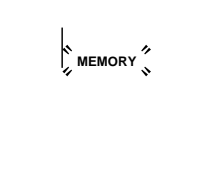
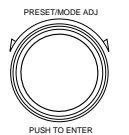

**DISPLAY button**  
 Pressing the DISPLAY button each time will change the indication as follows:  
 Frequency (preset No.) ↔ Listening mode

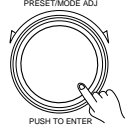
# Presetting FM/AM radio stations

1	
2	
3	 
4	 
5	

## Programming radio stations

1. **Select the frequency that you want to store in the memory.**  
(See Tuning in a radio station on page 24.)
  2. **Press the CHARACTER/MEMORY button.**  
"Preset In?" appears.
  3. **Press the SMART SCAN CONTROLLER.**  
The "MEMORY" indicator lights up on the display.
  4. **Select the desired memory number using SMART SCAN CONTROLLER.**
  5. **Press the SMART SCAN CONTROLLER.**  
The received station will be stored in the specified preset number.
- A total of 40 stations can be stored in the memory.

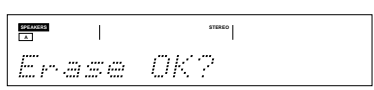
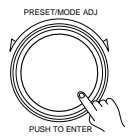
2	 
3	 
4	

## Canceling preset stations

1. **Select the preset station you wish to remove as explained in the previous section.**
2. **Press the CHARACTER/MEMORY button repeatedly.**  
"Preset Erase?" appears on the display.
3. **Press the SMART SCAN CONTROLLER.**  
"Erase OK?" appears.  
To stop canceling preset stations, press the CHARACTER/MEMORY button.
4. **Press the SMART SCAN CONTROLLER.**

# Selecting an input source

**2. Make sure that the SPEAKERS A indicator is lit on the display.**

If it is not lit, press the SPEAKERS A button.

**4. Adjust the sound volume to an appropriate level.**

Rotating the MASTER VOLUME control knob clockwise increases the sound volume.

Rotating the MASTER VOLUME control counterclockwise decreases the sound volume.

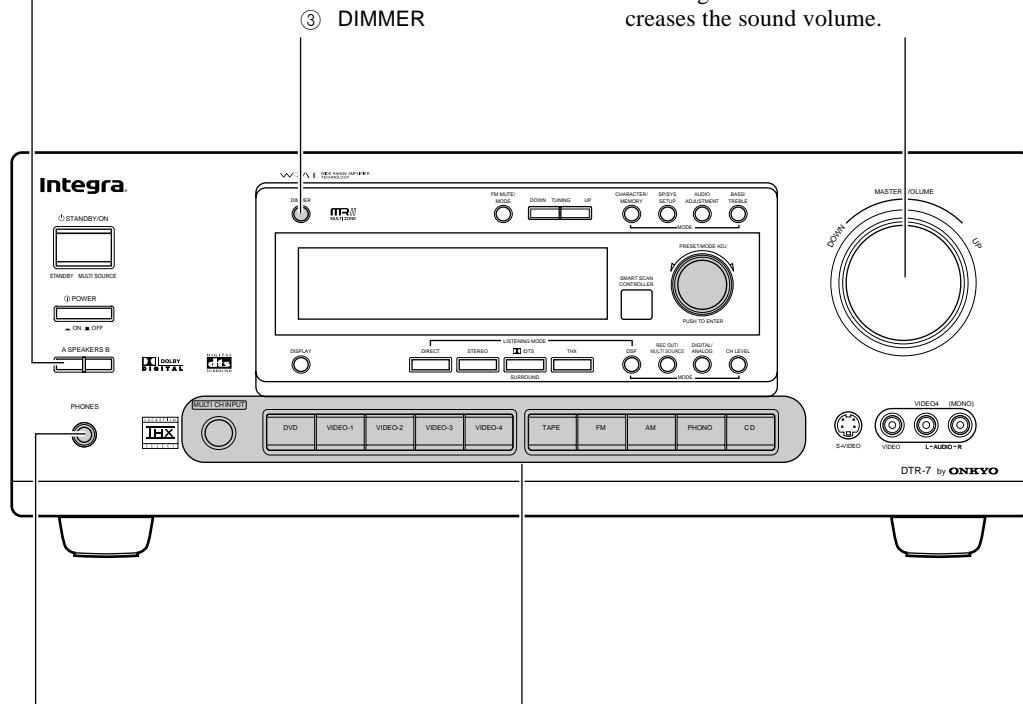

**4 PHONES**

**1. Press the desired input selector button or the MULTI CH INPUT button.**

The selected source name appears on the display.

If you have selected DVD, CD, VIDEO 1, VIDEO 2, VIDEO 3, or TAPE, perform "Digital Input Setup" (see page 23).

- See page 33 for information on MULTI CH INPUT.
- See page 32 if you have selected FM or AM.

**3. Start playing the selected input source.**

**Note:**

When you start playing the DVD player connected to the system, the message may appear such as "PCM 48 kHz" before the current encode format appears. This message is provided by the data from the DVD player, which does not indicate any product failure.

## Selecting an input source

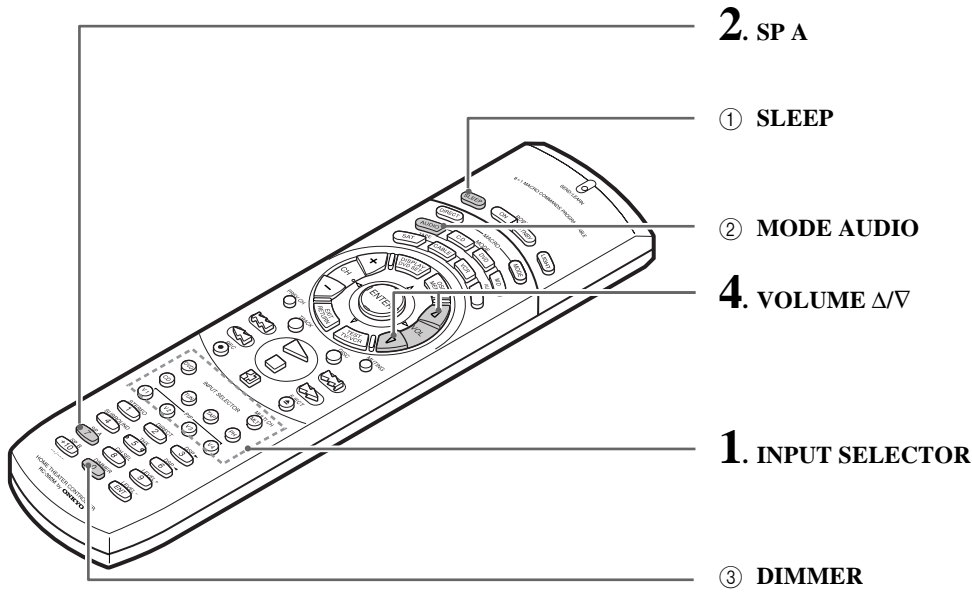

- ① This button allows you to set the sleep timer. (See page 31.)
- ② Press this button to set the mode in which you can operate the DTR-7/6.
- ③ Use this button to change the brightness of the display (normal or dim).
- ④ You can connect stereo headphones to the PHONES jack using a standard stereo plug. (When you connect headphones, the unit will enter STEREO mode automatically and no sound will be heard from the speakers.)

### If no sound is heard from the speakers, check the following items:

- When you have selected DVD, CD, VIDEO 1- 3, or TAPE, check the “digital input setup” is correct. (See page 23.)
- Make sure that the input signal format setting is correct. (See page 28,29.)
- The Muting function may be activated. Cancel the Muting function. (See “Muting the sound” on page 31.)
- Make sure that SPEAKERS A is selected. (See “Selecting the speaker system” on page 30.)

### Warning:

- Do not play CD-ROM discs that contain computer data as they may damage the speakers when the sound is amplified by the receiver.

3

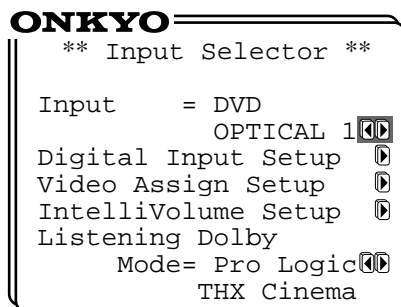

### • Selecting an input source using the on-screen display

Instead of using the input selector buttons, you can use on-screen display to select the desired input source.

1. Press the **OSD MENU** button.
2. Select “Input Selector” and then press the right edge of the **ENTER/Cursor** button.
3. Press the upper or lower edge of the **ENTER/Cursor** button to select “Input” and then press the right or left edge of the button to select an input source.
  - When you select DVD, CD, VIDEO 1- 3, or TAPE, set the digital input parameters on the Digital Input Setup screen. (See page 29.)
  - When you have selected TUNER, the currently selected preset number is displayed on the next line.
  - See page 33 for information on MULTICH INPUT.
4. Press the center of the **ENTER/Cursor** button, or press the **EXIT** button, to exit the setup mode.

# Selecting an input source

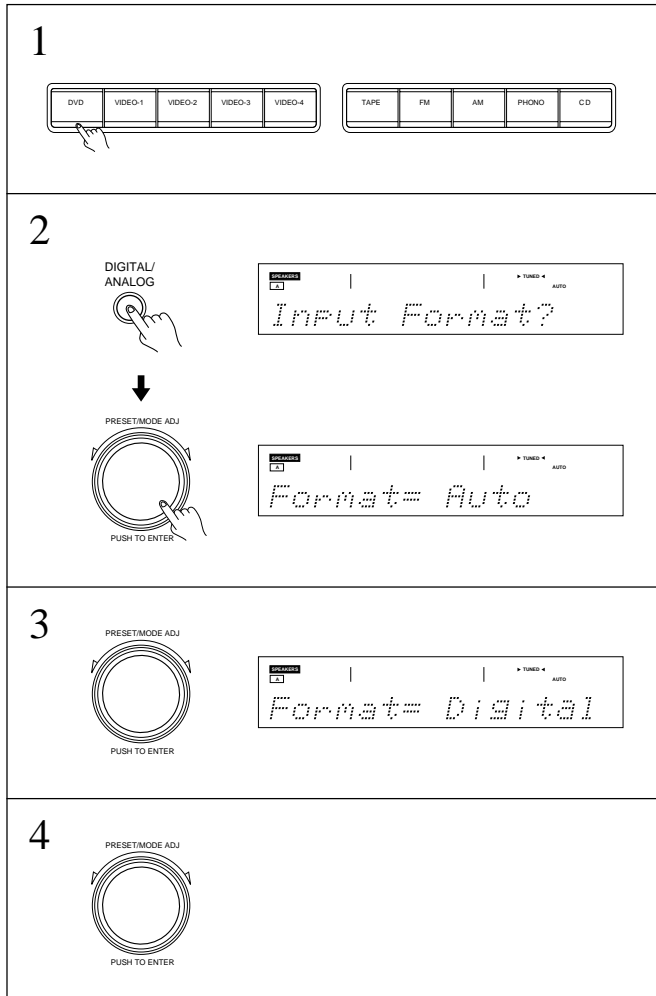

## Setting the input signal format (Digital Input Setup)

The input signal format defaults to “Automatic.” Although you can use this default setting normally, you may change it depending on the input signal format.

### Ex.) Setting the input signal format for DVD

1. Press the **DVD** input selector button.
2. Press the **DIGITAL/ANALOG** button twice to display the digital input format.  
Press the **SMART SCAN CONTROLLER**.  
You are now able to select the input signal format.
3. By rotating the **SMART SCAN CONTROLLER**, select the input signal format from among “Automatic,” “Digital,” “Analog,” “PCM,” and “DTS.”

#### Automatic (Automatic detection)

Input signal format (Dolby Digital, DTS, or PCM) used in the selected input source is detected automatically to execute the required decoding process. If no digital signal is input, the input signals to the analog input jacks will be played.

#### Digital (Digital input automatic detection)

Input digital signal format (Dolby Digital, DTS, or PCM) used in the selected digital input source is detected automatically to execute the necessary decoding process.

#### Analog (Analog audio signal processing)

The audio signals input from the equipment connected to the analog input jacks are played.

#### PCM (PCM signal processing)

A decoding process is executed only when PCM signals are input.

#### DTS (DTS signal processing)

A decoding process is executed only when DTS signals are input.

#### Notes:

- In “Automatic” or “Digital” mode, if the CD or LD is fast-forwarded during playback, decoded PCM signals may produce skipped sound. In such cases, change the digital audio format to “PCM.”
- If a CD or LD encoded in the DTS format is played back using “PCM” or “Analog” mode, a noise will be produced. This noise could damage the amplifier and speakers. Always use “Automatic”, “Digital”, or “DTS” mode when playing back DTS-encoded sources.

4. Press the **SMART SCAN CONTROLLER**.  
This completes the digital audio format setup.

## Selecting an input source

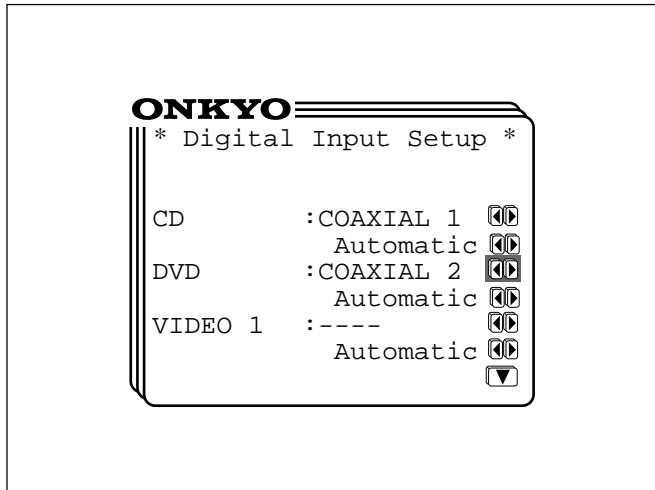

### • Using the on-screen display

1. Press the OSD MENU button.
2. Select "Input Selector" and then press the right edge of the ENTER/Cursor button.
3. Select "Digital Input Setup" and then press the right edge of the ENTER/Cursor button.

The "Digital Input Setup" screen appears. To display VIDEO 2 and later items, press the lower edge of the ENTER/Cursor button.

- Select the digital input connector from among "OPTICAL 1," "OPTICAL 2," "COAXIAL 1," "COAXIAL 2," and "-----."
  - If no digital input connector is assigned to the selected input source, it will be indicated as "-----."
  - To enter the setting, move the cursor vertically using the ENTER/Cursor button.
4. To set the input signal format, move the cursor to the line immediately below the input source and then press the right or left edge of the ENTER/Cursor button.
    - Select the digital audio format from among "Automatic," "Digital," "Analog," "PCM," and "DTS."
    - Holding down the right or left edge of the ENTER/Cursor button sequentially changes the setting.
  5. Press the center of the ENTER/Cursor button, or press the EXIT button, to exit the setup mode.

### Notes on DTS

1. If you play a CD or LD that supports DTS when the "Analog" or "PCM" setting is selected on the DTR-7/DTR-6, the DTS encoded signal will not be decoded and noise will be output. This noise could damage the amplifier and speakers. Therefore, be sure to select "Automatic," "Digital" or "DTS" and use the digital input jacks (OPTICAL1/2 /COAXIAL1/2) to connect the DTS source.
2. If you play a CD or LD that supports DTS when the "Automatic", or "Digital" setting is selected, you may hear a noise for a short while until the DTS decoder recognizes the DTS encoded signal and starts operating. This is not a malfunction.
3. If you press the PAUSE or SKIP button on the player while playing a DTS source, a short noise may be heard. This is not a malfunction. In such cases, try playing the source in the "DTS" mode.
4. The DTS indicator on the DTR-7/DTR-6 lights up while it plays the DTS source. When playback concludes and the DTS signal transmission stops, the DTR-7/DTR-6 remains in DTS mode and the DTS indicator remains lit. This prevents noise when you operate the PAUSE or SKIP button on the player. Therefore, if the source switches from the DTS signal to the PCM signal immediately, the PCM signal may not be played. In this case, stop the playback of the source on the player for about three seconds, then resume playback.
5. Some CD players and LD players may be unable to play DTS sources correctly even if you connect the player to the DTR-7/DTR-6 digitally. This is because the digital signal has been processed (such as the output level, sampling frequency, frequency response, etc.), and the DTR-7/DTR-6 cannot recognize the signal as DTS data. Therefore, you may hear noise when you play a DTS source while processing the signal.
6. The OUT jacks of the VIDEO-1, VIDEO-2, and TAPE connectors output analog audio signals. Do not record CDs or LDs that support DTS using these jacks. Otherwise, you will record a DTS-encoded signal as noise.



# Selecting an input source

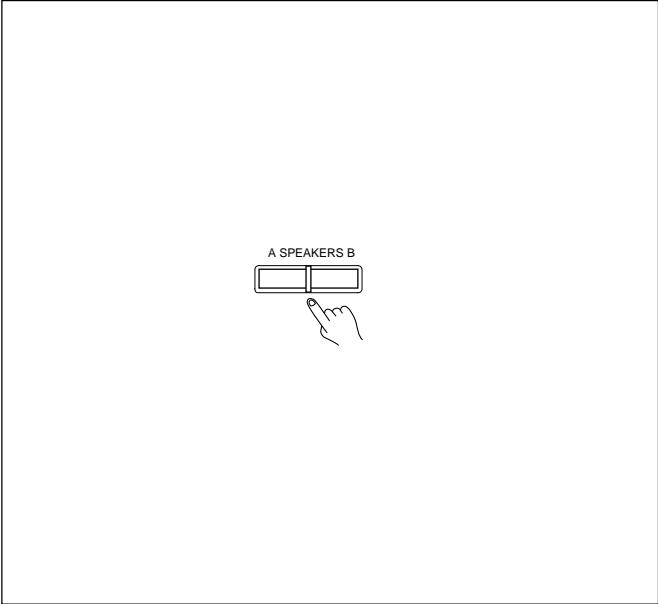

## Selecting the speaker system

The DTR-7/DTR-6 can connect to two speaker systems. You can switch between the two speaker systems by using the SPEAKERS A and B buttons.

### Selecting Speaker system A (SPEAKERS A indicator appears.)

Press the SPEAKERS A button to turn on or off the speakers connected to the FRONT SPEAKERS A, CENTER SPEAKER and SURROUND SPEAKERS terminals.

### Selecting Speaker system B (SPEAKERS B indicator appears)

Press the SPEAKERS B button to turn on or off the speakers connected to the FRONT SPEAKERS B terminals.

### Notes:

- Be sure to select Speaker system A during surround playback or when multi-channel input is enabled.
- Selecting Surround playback when both speaker systems are on automatically turns off the speaker system B. Similarly, turning on both speaker systems during Surround playback automatically sets the listening mode to STEREO.

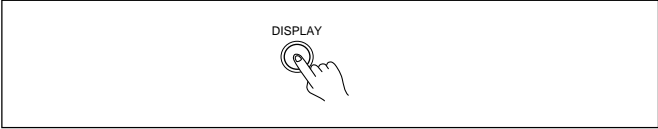

## Changing the display

The display changes each time you press the DISPLAY button during playback.

### FM/AM:

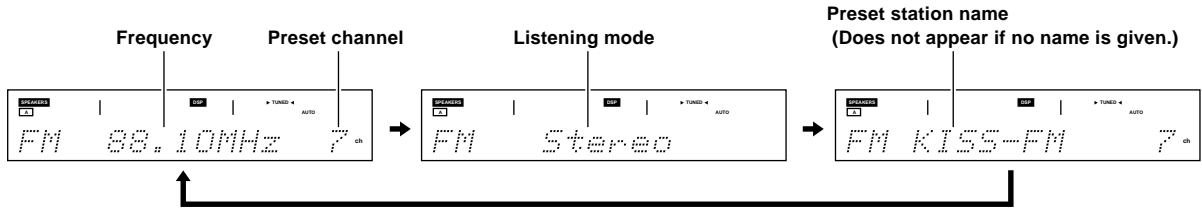

### Other sources:

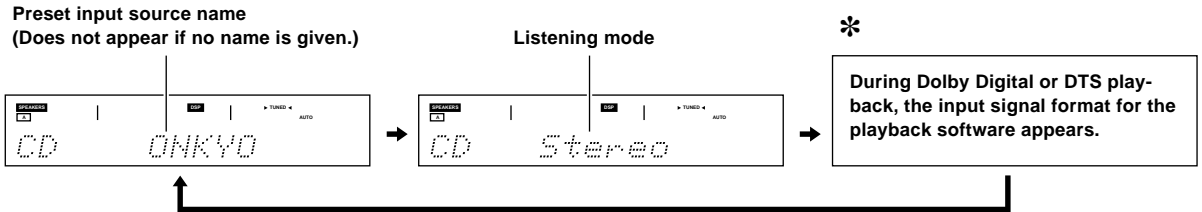

- For analog signals, "Input source name" or "Listening mode" can be selected.
- "Input signal format" returns to "Listening mode" within 3 seconds.

### Input signal format:

- Current sampling frequency displays for PCM signals (ex. "PCM 44.1 kHz"). No correct information displays, however, for the frequencies other than 32, 44.1, 48, and 96 kHz.
- For Dolby Digital/DTS, the surround channels information may also display. For example, "Dolby D 3/2" indicates that the source outputs signals for three front channels and two surround channels in Dolby Digital mode.

## Selecting an input source

### Remote controller



### Muting the sound (Muting function, remote controller only)

Use this function to turn off the playback sound immediately. For example, you can use it when you receive a phone call when listening to music.

#### Press the MUTING button.

The display shows "Muting." Now the sound output to the speakers and headphones stops.

Press the MUTING button again to turn on the sound output.

#### Note:

The Muting function will be canceled automatically if the receiver is set in the standby mode.

### Remote controller

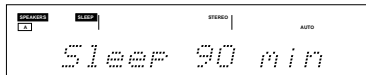

### Falling asleep with music (Sleep function, remote controller only)

You can turn off the power to the DTR-7/DTR-6 automatically after a specified time period.

#### 1. Press the MODE AUDIO button.

#### 2. Press the SLEEP button.

The display shows "Sleep 90min," which means the receiver automatically enters the standby mode after 90 minutes.

#### 3. Press the SLEEP button repeatedly until the desired sleep time is displayed.

Each time you press this button, the time decreases by 10 minutes.

#### To check how much time is left before the unit turns off...

Press the SLEEP button when the Sleep function is enabled.

#### Note:

Pressing the SLEEP button when the Sleep time display shows 10 minutes or less cancels the Sleep function.

BASS/  
TREBLE



### Adjusting the tone (Bass and treble adjustment)

The bass and treble levels can be adjusted in the range of +/-12 in units of 2.

You cannot perform this adjustment when the listening mode is "THX" or "Direct."

#### 1. Press the BASS/TREBLE button.

The display shows "Bass=."

Rotate the SMART SCAN CONTROLLER to adjust the bass level.

#### 2. Press the SMART SCAN CONTROLLER.

The display shows "Treble=."

Rotate the SMART SCAN CONTROLLER to adjust the treble level.

#### 3. Press the SMART SCAN CONTROLLER.

#### • Adjusting the bass and treble levels with the on-screen display

#### 1. Press the OSD MENU button.

#### 2. Select "Listening mode Setup" and then press the right edge of the ENTER/Cursor button.

#### 3. Select "Listening Mode" and then press the right edge of the ENTER/Cursor button

#### 4. Select "Tone Control" and then press the right edge of the ENTER/Cursor button.

The "Tone Control Setup" screen appears.

Press the upper or lower edge of the ENTER/Cursor button to select "Bass" or "Treble" and then press the right or left edge of the button to adjust the bass or treble level.

Select "Set to Flat" and then press the right edge of the ENTER/Cursor button to restore the "flat" bass and treble sound.

#### 5. Press the center of the ENTER/Cursor button, or press the EXIT button, to exit the setup mode.

#### Note:

You cannot perform this adjustment when the listening mode is "Direct" or "THX (DTR-7 only)."

4

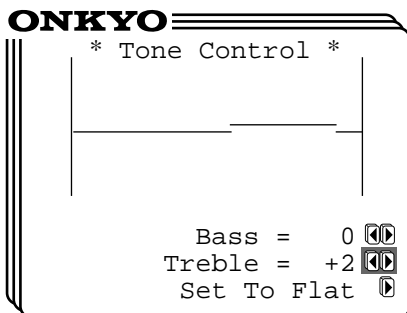

# Selecting a preset station

## 2. Rotate the SMART SCAN CONTROLLER.

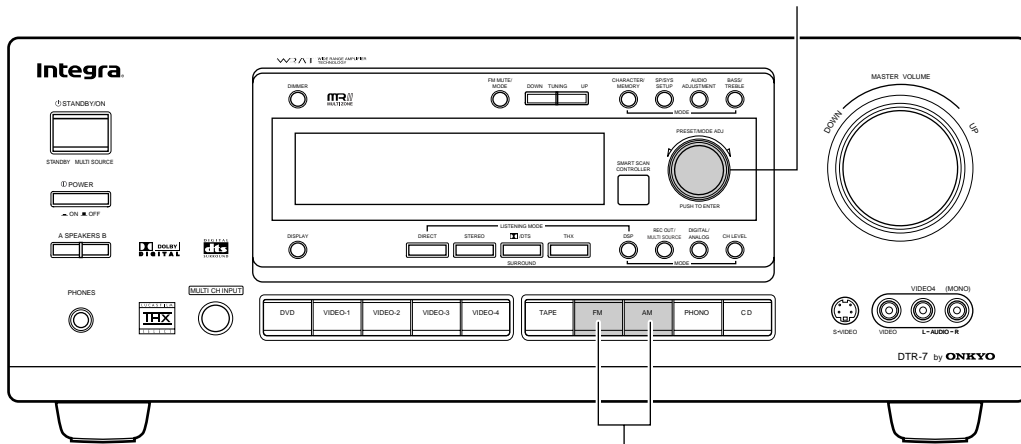

### 1. Press the AM or FM button.

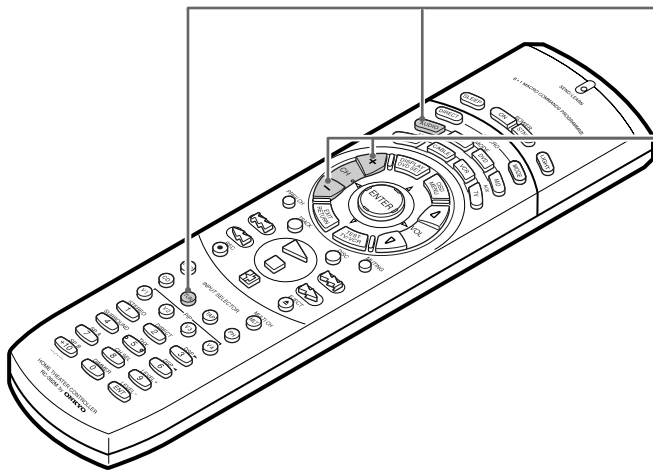

### 1. Press the MODE AUDIO button and then the TUNER button.

### 2. Press the CH (+ or -) button to select the desired preset number.

3,4

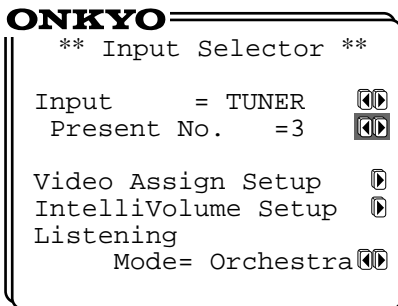

5

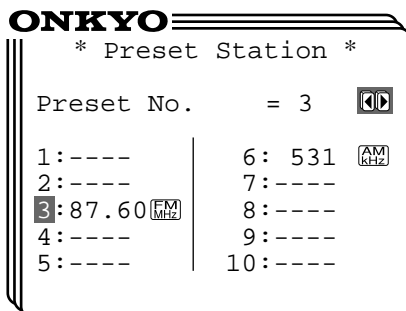

### • Using the on-screen display

1. Press the OSD MENU button.
2. Select "Input Selector" and then press the right edge of the ENTER/Cursor button.
3. Select "Input" and then press the right or left edge of the ENTER/Cursor button to select "TUNER."
4. Select "Preset No." and then press the right edge of the ENTER/Cursor button
5. Press the right or left edge of the ENTER/Cursor button to select the desired preset number.
6. Press the center of the ENTER/Cursor button, or press the EXIT button. The on-screen display disappears.

# Playing a multichannel input source

1

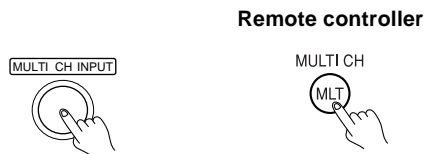

Remote controller

3

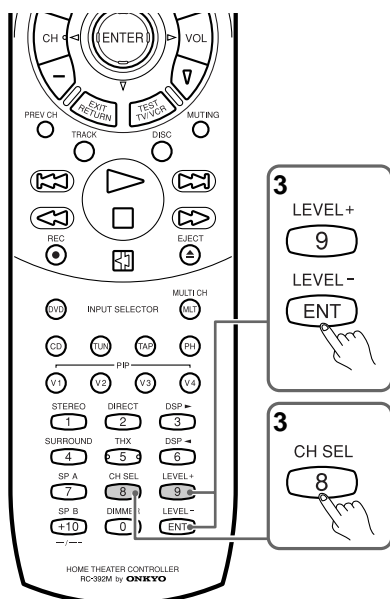

6

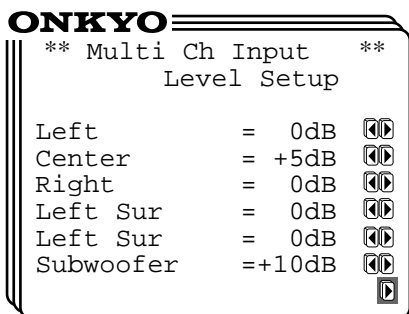

## Setting the MULTI CHANNEL INPUT

To play back an input source you connected with the MULTI CHANNEL INPUT connectors, you must set the output level of each speaker. Also, note that this output level setting must be performed independent of the speaker levels you set using the test tone (see page 21).

Before playing movie soundtracks etc. in the multichannel input mode, check again that the source is connected properly (see page 9).

### 1. Press the MULTI CH INPUT button.

If you wish to assign a video source to the multichannel input source, perform the following setting. If you do not wish to do so, proceed to step 3.

1. Press the SP/SYS SETUP button repeatedly until "Video Assign?" appears and then press the SMART SCAN CONTROLLER.

2. Rotate the SMART SCAN CONTROLLER to select the video source you wish to assign and then press the SMART SCAN CONTROLLER.

### 2. Start playing the component connected to the MULTI CHANNEL INPUT connectors.

### 3. Press the CH SEL button on the remote controller to select the speaker. Then, press the LEVEL (+ or -) button to adjust the output level.

In the listening position, adjust the speaker output level so that you can hear the same sound volume from all speakers. For the right front, left front, center, right surround and left surround speakers, the output levels can be adjusted within the range between -12dB/+12 dB. The adjustment range of the subwoofer, however, is -30 to +10 dB.

### Using the front panel

1. Press the CH LEVEL button.
2. Rotate the SMART SCAN CONTROLLER to select the output level.

Repeat the above steps until you set the output levels for all speakers.

### • Using the on-screen display

1. Press the OSD MENU button.
2. Select "Input Selector" and press the right edge of the ENTER/Cursor button.
3. Press the right or left edge of the ENTER/Cursor button to select "MULTI CH." Then, press the center of the ENTER/Cursor button.

The "Multi Ch Input" screen appears.

4. If you wish to skip assigning a video source, proceed to step 5. To assign a video source, select "Video Assign Setup" and then press the right edge of the ENTER/Cursor button. When "Video Assign Setup" screen appears, move the cursor (which is already located at "MULTI CH") rightward or leftward to select the video source you wish to assign. When selected, press the center of the ENTER/Cursor button to return to the previous screen.
5. Select "Level Setup" and press the right edge of the ENTER/Cursor button.

"Multi Ch Input Level Setup" screen appears.

6. Press the upper or lower edge of the ENTER/Cursor button to select the item. Then, press the right or left edge of the button to select the desired parameter.

In the listening position, adjust the speaker output level so that you can hear the same sound volume from all speakers. For the right front, left front, center, right surround and left surround speakers, the output levels can be adjusted within the range of -12 dB/+12 dB. The adjustment range of the subwoofer, however, is -30 to +10 dB.

7. Press the center of the ENTER/Cursor button, or press the EXIT button, to exit the setup mode.

# Using the Listening Modes

## Before Using Listening Mode

### Listening Modes

The DTR-7/DTR-6's surround sound enables you to enjoy the presence of a movie theater or concert hall in your room.

Before using a listening mode, make sure the Speaker Setup parameters have been set (refer to page 18 ~ 23). Once the parameters have been set, it is not necessary to set them again.

The configuration of the speakers are very important for the surround sound. Refer to "connecting speakers" on page 10.

### DOLBY DIGITAL Surround, DTS (Digital Theater System)

This 5.1-channel digital surround format enables you to individually record and play five full-range (20Hz-20kHz) channels (left and right front, center, two surround channels) plus an LFE channel (Low Frequency Effect) for the low-range effect sound. It will create a realistic sound that could be heard in the theaters and concert halls.

**DOLBY DIGITAL:** Select this option when you play a DVD video that has a  mark.

**DTS:** Select this option when you play a DVD player, video disc, or CD that has a  mark.

### DOLBY PRO LOGIC Surround

This surround format consists of four channels (left and right front, center, and monaural surround channels) and emphasizes the center channel. This format is very effective for panning music, conversation, and three-dimensional sound movement output from three front channels. It also simulates the atmosphere and surround effects of the sound reflected from the side and rear walls of the theater. Select this option when you play a VHS, VHS Hi-Fi, laser disc, or DVD video that has a  mark.

### Home THX Cinema Surround (DTR-7 only)

#### DOLBY DIGITAL/DTS/DOLBY PRO LOGIC/THX CINEMA

In these modes, Dolby Digital, Dolby Pro Logic or DTS Surround is reprocessed using a technique called "Home THX processing." Home THX processing was developed by the surround engineers at Lucasfilm Ltd. for accurate reproduction of soundfields in the home environment as the filmmaker intended, equivalent to those obtained in a well-furnished movie theater. For Home THX Cinema Surround playback, we recommend that you use a THX speaker system certified by Lucasfilm Ltd. (such as Onkyo's THX speaker system HTS SYSTEM-2).

### Surround modes incorporating Integra's original Surround processing

#### Surround mode suitable for movie soundtracks

In the following surround modes, additional processing is applied to the Dolby Digital, Dolby Pro Logic or DTS Surround.

#### ACTION

Suitable for movie soundtracks involving a lot of special effect sounds.

#### MUSICAL

Suitable for musical film soundtracks, where importance is placed on the music, environmental sound, and front image.

### Integra's listening modes

**MONO MOVIE (DTR-7 only) :** This mode is suitable for playback monaural recordings such as old movie soundtracks. The center channel delivers unprocessed original sound, whereas the other channels delivers processed center-channel sound with appropriate reverberation. Thus, you can enjoy monaural sound with the atmosphere of a movie theater.

**ORCHESTRA :** This mode is suitable for classics and opera music. The center channel is cut and the surround channels are emphasized to widen the stereo image. It will simulate a natural reverberation that can be created in a large hall.

**UNPLUGGED :** This mode is suitable for acoustic instrumental sounds, vocals, and jazz music. By emphasizing the front stereo image, it will simulate the acoustics in front of the stage.

**STUDIO-MIX :** This mode is suitable for rock and popular music. Lively sounds with a powerful acoustic image will make you feel as if you are in a club.

**5CH STEREO :** This mode is useful for background music. The front and surround channels will create a stereo image.

**TV LOGIC :** This mode offers a realistic acoustics of a TV program being aired in the TV studio. It enhances the entire surround sound and clarity of conversation.

**DIRECT :** This mode delivers pure sound with the minimum sound quality adjustment and filtration. To attain it, the sound recorded for the Right and Left front channels is output to the Right and Left front speakers only and not output to the subwoofer.

#### STEREO

Select this mode when you do not wish to use the surround mode. All input sound is output from the front speakers.

- **A system with L/R front and center speakers**

The following modes are available:

#### DOLBY 3 STEREO

The surround channel sound is output from the left and right front speakers.

#### STEREO

This is a normal stereo mode. Surround mode is cancelled.

#### DIRECT

See the description above.

- **A system with L/R front speakers**

The following mode is available:

#### STEREO

This is a normal stereo mode.

#### DIRECT

See the description above.

## DSP (Digital Signal Processor)

The DSP converts the audio signals into digital audio format to create sound reflection. This yields an effect that makes you feel like listening to a live performance.

The following illustration shows how reflected sound reaches the audience in a concert hall. Integra's DSP and advanced technologies let you get such a sound reflection effect from the unit.

#### Note:

The concert hall effect is produced from the reflections and reverberations contained in the original recording. These are converted into reflected sound that is reproduced from four directions. Thus, in some cases an unnatural impression can be conveyed if there are too few reflections in the recording or if the effects in the original recording were produced artificially.

Example: Sound reflection in a concert hall

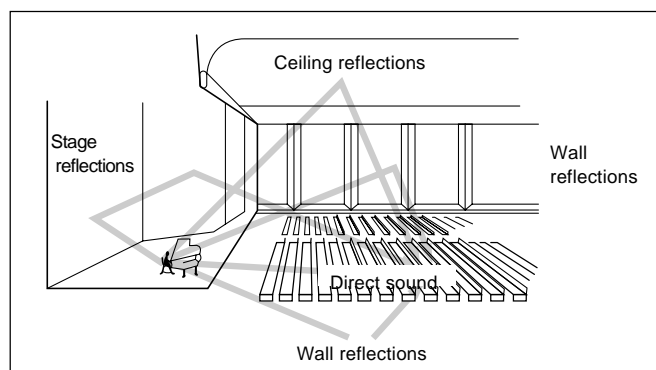

## Using the listening modes

- 2.** Use the **LISTENING MODE** buttons to select the desired listening mode and then start playing the selected source.

Use these buttons to set the listening mode parameters. (See page 38.)

- 3.** **MASTER VOLUME** control knob

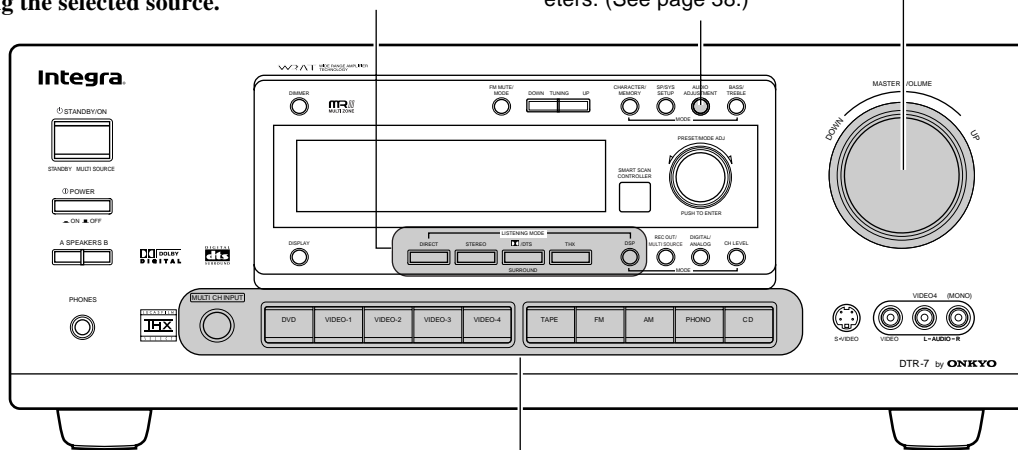

- 1.** Press one of the **INPUT SELECTOR** buttons to select the desired sound source.

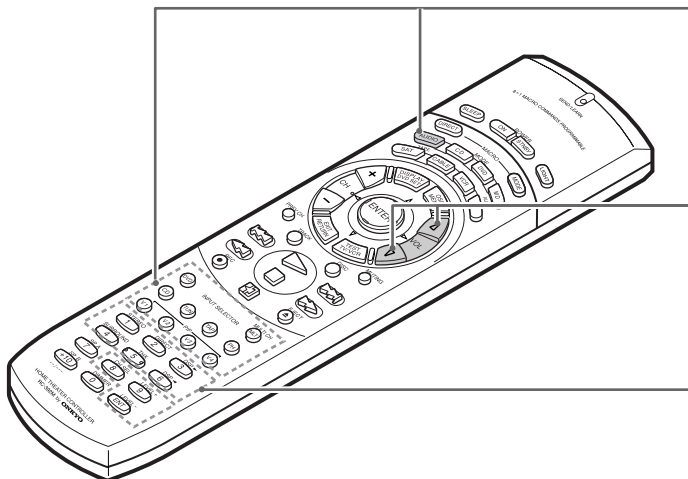

- 1. Input selector buttons**

Select the desired input source.

To change the input source using the remote controller, press the **MODE AUDIO** button before pressing the input selector button.

- 3. VOLUME buttons**

Use these buttons to adjust the sound volume.

- 2. Listening mode button**

Use these buttons to select the desired listening mode and then start playing the selected source.

# Using the listening modes

The LISTENING MODE button names on the unit may vary depending on the model.

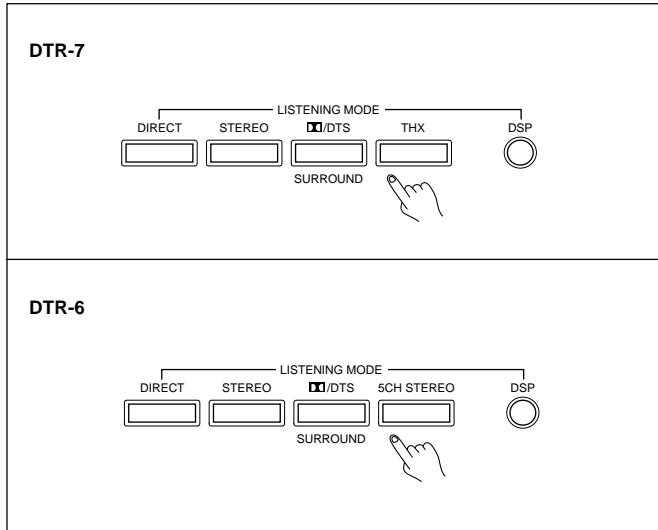

## Using the listening modes

Pressing the DSP button and then rotating the SMART SCAN CONTROLLER lets you view all the listening modes. You can select directly from four listening modes. The mode you can select may vary depending on where the unit is purchased.

- DIRECT** : Press this button if you wish to enjoy pure direct sound.
- STEREO** : Press this button to listen to a normal stereo audio.
- DDD/DTS** : Press this button when you wish to play Dolby Pro Logic, Dolby Digital, DTS Surround, software.
- 5CH STEREO(DTR-6)** : Press this button to play 5-ch stereo sound (see the previous page).
- THX(DTR-7)** : Press this button when THX speakers are used.

### Notes:

- To play a Dolby digital or DTS Surround source, you need to connect the sound source with a correct digital input connector.
- When you play the Dolby digital or DTS Surround source, the receiver automatically enters Dolby Digital Surround (stereo) or DTS Surround (stereo) mode respectively.

### THX

Movies which have been encoded in Dolby Digital, DTS, MPEG and Dolby Pro Logic can all benefit by activating the THX mode. THX should be activated only when watching movies which were mixed for playback in large movie theatre environments. THX need not be activated for music, movies that were made especially for television or shows such as sports programming, talk shows, etc. This is because they were mixed in a small room environment.

### Dial norm

Dialogue Normalization (Dial Norm) is a feature of Dolby Digital. When playing back software which has been encoded in Dolby Digital, sometimes you may see a brief message in the front panel display which will read Dial Norm XdB (X being a numeric value). Dialogue Normalization serves to let you know if the source material has been recorded at a higher or lower level than usual. For example, if you see the following message: Dial Norm +4dB in the front panel display, to keep the overall output level constant just turn down the volume control by 4dB. In other words, the source material that you are listening to has been recorded 4dB louder than usual. If you do not see a message, then no adjustment of the volume control is necessary.

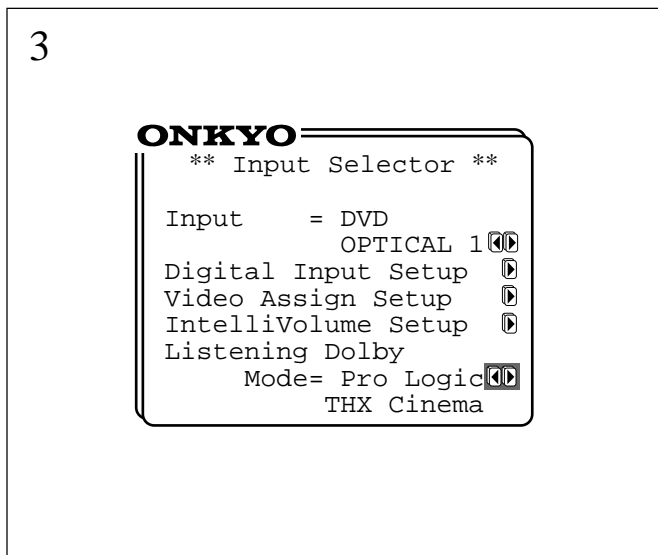

### • Selecting an Listening mode using the on-screen display

Instead of using the Listening mode buttons, you can use on-screen display to select the desired input source.

1. Press the OSD MENU button.
2. Select "Input Selector" and then press the right edge of the ENTER/Cursor button.
3. Press the upper or lower edge of the ENTER/Cursor button to select "Listening mode" and then press the right or left edge of the button to select an listening mode.
4. Press the center of the ENTER/Cursor button, or press the EXIT button, to exit the setup mode.

## Using the listening modes

### Input sources and listening modes

The available listening modes vary depending on the input source.

The following table shows each input source and the available listening modes.

\*Available for DTR-6.

Listening mode	Input source	analog/PCM	Dolby Digital		DTS	MPEG	
			3/2ch	2/0ch		3/2ch	2/0ch
Stereo (3 Stereo)	*	<input type="radio"/>	<input type="radio"/>	<input type="radio"/>	<input type="radio"/>	<input type="radio"/>	<input type="radio"/>
Dolby Pro Logic	*	<input type="radio"/>					
THX Cinema		<input type="radio"/>					
Action		<input type="radio"/>					
Musical		<input type="radio"/>					
Mono Movie		<input type="radio"/>					
Orchestra	*	<input type="radio"/>					
Unplugged	*	<input type="radio"/>					
Studio-Mix	*	<input type="radio"/>					
TV Logic	*	<input type="radio"/>					
5ch stereo	*	<input type="radio"/>					
Direct	*	<input type="radio"/>					
Dolby Digital	*		<input type="radio"/>				
THX Cinema			<input type="radio"/>				
Action			<input type="radio"/>				
Musical			<input type="radio"/>				
Mono Movie			<input type="radio"/>				
Orchestra			<input type="radio"/>				
Unplugged			<input type="radio"/>				
Studio-Mix			<input type="radio"/>				
TV Logic			<input type="radio"/>				
Dolby Digital Pro Logic	*			<input type="radio"/>			
Action				<input type="radio"/>			
Musical				<input type="radio"/>			
DTS	*				<input type="radio"/>	<input type="radio"/>	
THX Cinema					<input type="radio"/>	<input type="radio"/>	
Action					<input type="radio"/>	<input type="radio"/>	
Musical					<input type="radio"/>	<input type="radio"/>	
Mono Movie					<input type="radio"/>	<input type="radio"/>	
Orchestra					<input type="radio"/>	<input type="radio"/>	
Unplugged					<input type="radio"/>	<input type="radio"/>	
Studio-Mix					<input type="radio"/>	<input type="radio"/>	
TV Logic					<input type="radio"/>	<input type="radio"/>	

- For Dolby Digital only typical input signals are shown here. 3/2ch, for example, means that the source outputs signals for three front channels and two surround channels. The available listening modes vary depending on the input signal.
- The table shown above lists the input sources and listening modes available when the speakers are installed in a full configuration (right/left front, center, and right/left surround speakers). Without surround speakers, set the listening mode to "STEREO (3 Stereo)" or "Direct."



# Setting the listening mode parameters

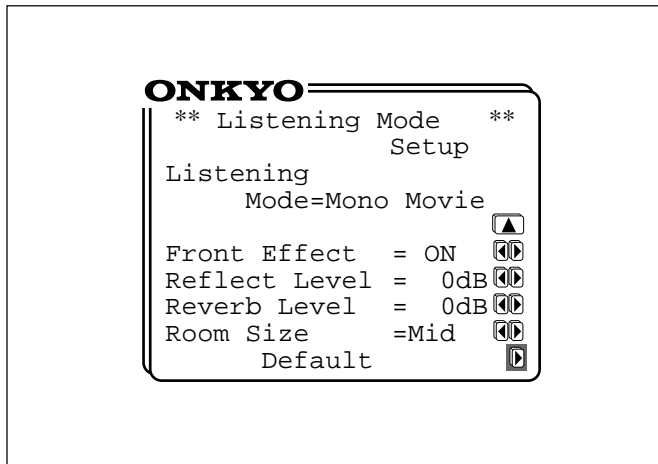
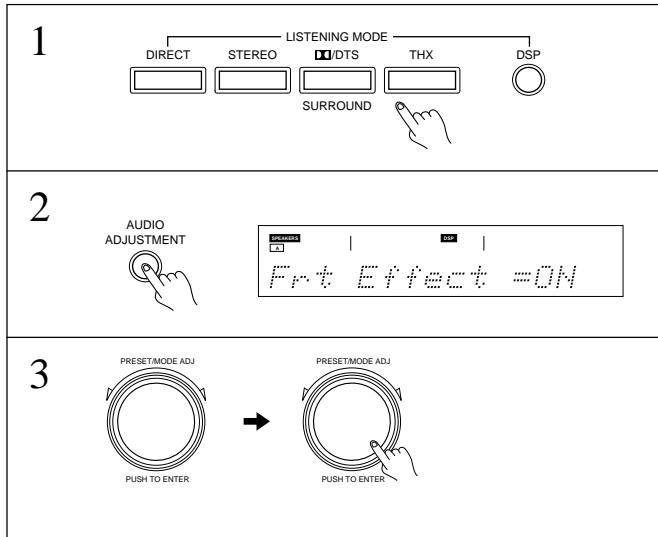

## How to set the listening mode parameters

To set the listening mode parameters, you first press the AUDIO ADJUSTMENT button to select the item and then rotate the SMART SCAN CONTROLLER to select the parameter.

1. Select the listening mode for which you wish set parameters.
2. Press the AUDIO ADJUSTMENT button until "Frt Effect=..." appears.  
The parameters you can set vary depending on the selected listening mode. You can press this button to display the available parameters one by one.
3. Rotate the SMART SCAN CONTROLLER to change the parameter setting.
4. Press the SMART SCAN CONTROLLER.

### Using the on-screen display

If you use the on-screen display to set a listening mode, you can set the relevant parameters on the same screen.

1. Press the OSD MENU button.
2. Select the "Listening Mode" and press the right edge of the ENTER/Cursor button.
3. Press the upper or lower edge of the ENTER/Cursor button to select "Listening Mode."  
Then, press the right or left edge of the button to select the listening mode.  
The parameter items available for the selected listening mode are displayed.
4. Press the upper or lower edge of the ENTER/Cursor button to select the item and then press the right or left edge of the button to set a value.  
If you select "LFE Level," "Setup," etc., an additional screen will appear. Set the value for each item in the similar manner.
5. Press the center of the ENTER/Cursor button, or the EXIT RETURN button, to exit the setup mode.

**Default:** Select "Default" to reset each parameter to the factory-set default.

Listening mode	Parameter	Re-EQ*	LateNight*	LFE level*	Front Effect*	Reflect Level*	Reverb Level	Room Size
Stereo(3 Stereo)	*							
Dolby Pro Logic	*	○						
THX Cinema		○						
Action/Musical		○			○	○	○	○
Mono Movie		○			○	○	○	○
Orchestra/Unplugged/Studio-Mix/TV Logic	*	○			○	○	○	○
5ch Stereo	*							
Direct	*							
Dolby Digital	*	○	○	○				
THX Cinema		○	○	○				
Action/Musical		○	○	○	○	○	○	○
Mono Movie/Orchestra/Unplugged/Studio-Mix/TV Logic		○	○	○	○	○	○	○
Dolby Digital Pro Logic	*	○	○	○				
Action/Musical		○	○	○	○	○	○	○
DTS	*	○		○				
THX Cinema		○		○				
Action/Musical		○		○	○	○	○	○
Mono Movie/Orchestra/Unplugged/Studio-Mix/TV Logic		○		○	○	○	○	○

\*Available for DTR-6.

(The detailed information on the listening mode parameters is provided on the next page.)

# Setting the listening mode parameters

## Listening mode parameters

### • Re-EQ (Cinema Re-Equalization)

Select "ON" or "OFF."

The Re-EQ function is effective except for "5CH STEREO" and "DIRECT."

Re-Equalization takes the edginess or "brightness" out of your home cinema sound, compensating for the fact that sound mixed for theaters will sound too bright when played back through speakers in the home environment.

### • Late Night

Select "High," "Low," or "OFF."

Cinema sound has a vast dynamic range and therefore, to hear quiet sound such as environmental sound and human conversations, it must be played back at large sound volumes. When this parameter is set to "High" or "Low," however, the dynamic range of the sound is narrowed down to allow you to hear easily minute sound at low volumes. This function is useful if you wish to play a movie at low volumes, especially in midnight.

#### Notes:

- The depth of the Late Night effect is determined by Dolby Digital software. Some sounds may produce no or little effect.
- The Late Night function is effective only on Dolby Digital encoded software.

### • LFE (Low Frequency Effect) level

This parameter is used to adjust the level of LFE in Dolby Digital, or DTS software. When this parameter is selected, the following screen appears.

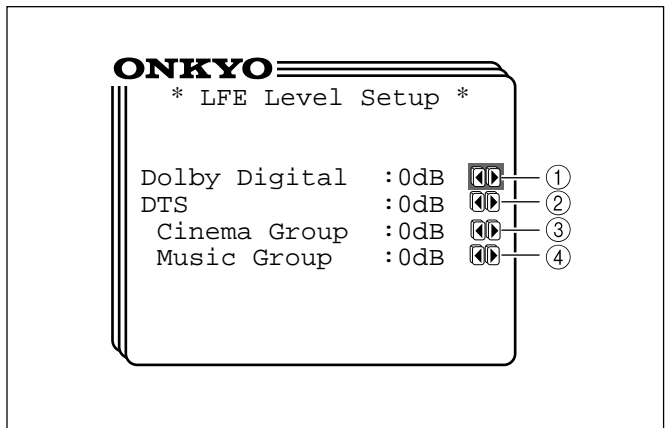

1. **Adjust this parameter when the source is "Dolby Digital."**  
Select "-∞ dB," "-20dB," "-10dB," or "0dB."  
The recommended setting is "0dB."
2. **Adjust this parameter when the source is "DTS" and the surround mode is "DTS."**  
Select "-∞ dB," "-20dB," "0dB," or "+10dB."  
The recommended setting is "+10dB."
3. **Adjust this parameter when the source is "DTS" and the listening mode is "DTS Action," "DTS Musical," "DTS THX," or "DTS Mono Movie."**  
Select "-∞ dB," "-20dB," "-10dB," or "0dB."  
The recommended setting is "0dB."

### 4. Adjust this parameter when the source is "DTS" and the listening mode is "DTS Orchestra," "DTS Unplugged," "DTS Studio-Mix," or "DTS TV Logic."

Select "-∞ dB," "-10dB," "0dB," or "+10dB."  
The recommended setting is "+10dB."

#### Note:

- The LFE level setting is effective only on Dolby Digital or DTS software.  
With some software, this setting may produce no effect.

### • Front Effect

Select "ON" or "OFF."

Some live recordings contain acoustic reverberation. When you play these sources, more reverberation will be applied by the DSP, creating too much reverb effects and the sound loses its frame or presence. In this case, set FRONT EFFECT to OFF. No reverberation from the DSP will be applied to the sound output from three front channels, and the sound source will be played as it is without any further reverberation.

#### Note:

The Front Effect function is effective only on the Action, Musical, MonoMovie, Orchestra, Unplugged, Studio-Mix, and TV Logic sound.

### • Reflect Level

Set a value between -5 and +5 dB, in units of 1 dB.

You can adjust the strength of direct sound reflection, depending on the playback source material, your audio room conditions, and so on.

### • Reverb Level (DTR-7 only)

Set a value between -5 and +5 dB, in units of 1 dB.

Adjust the depth of acoustic reverberation, depending on the playback source material, your audio room conditions, and so on.

### • Room Size (DTR-7 only)

Set "Large," "Mid," or "Small."

Change the virtual hall size set for each surround mode.

# Assigning a video source to each audio input source

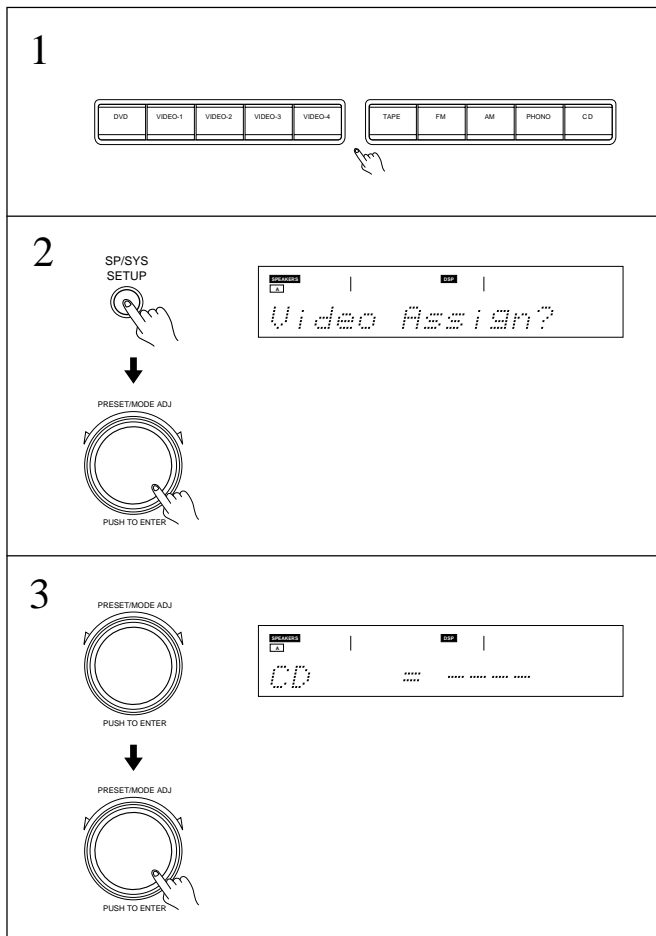

## Assigning a video source to each audio input source (video Assign Setup)

You can assign a video source to audio input sources such as CD. By doing so, you can play a CD or other audio source while showing the assigned video images on the TV.

1. Select the desired audio input source by pressing the corresponding input selector button.
2. Press the SP/SYS SETUP button repeatedly until "Video Assign?" is displayed. Then Press the SMART SCAN CONTROLLER.

The video assign mode has been set.

3. Rotate the SMART SCAN CONTROLLER to select the video source you wish to assign.

You can select one from among 6 video sources: DVD, VIDEO 1, VIDEO 2, VIDEO 3, VIDEO 4, and ---- (None).

Press the SMART SCAN CONTROLLER.

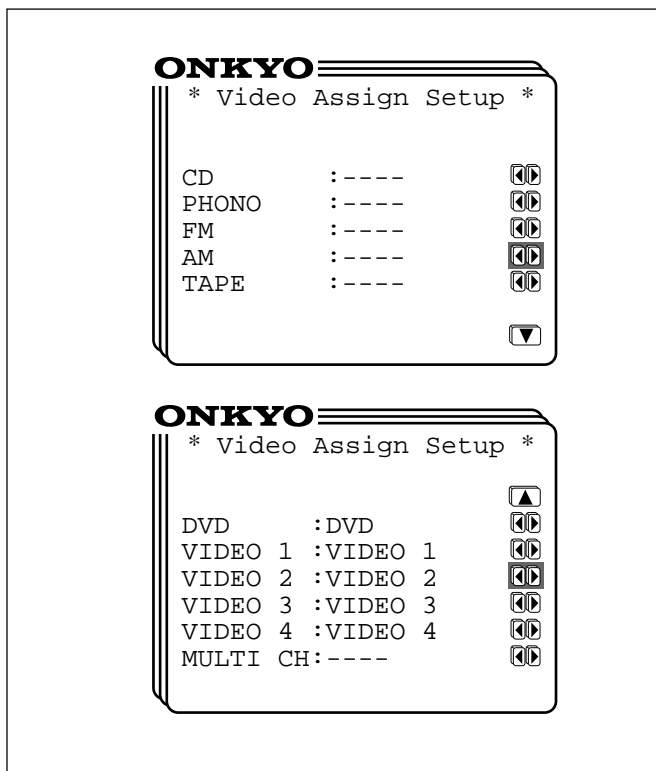

### • Using the on-screen display

1. Press the OSD MENU button.
2. Select "Input Selector" and then press the right edge of the ENTER/Cursor button.
3. Select "Video Assign Setup" and then press the right edge of the ENTER/Cursor button.  
"Video Assign Setup" screen is displayed.  
When the cursor is on "TAPE," you can press the lower edge of the ENTER/Cursor button to display additional items.  
When the cursor is on "DVD," you can press the upper edge of the ENTER/Cursor button to display the previous items.
4. Press the upper or lower edge of the ENTER/Cursor button to select the audio input source and then press the right or left edge of the button to assign a video source.  
You can select one from among 6 video sources: DVD, VIDEO 1, VIDEO 2, VIDEO 3, VIDEO 4, and ---- (None).
5. Press the center of the ENTER/Cursor button, or press the EXIT button, to exit the setup mode.

# Giving a name to each input source and preset radio station

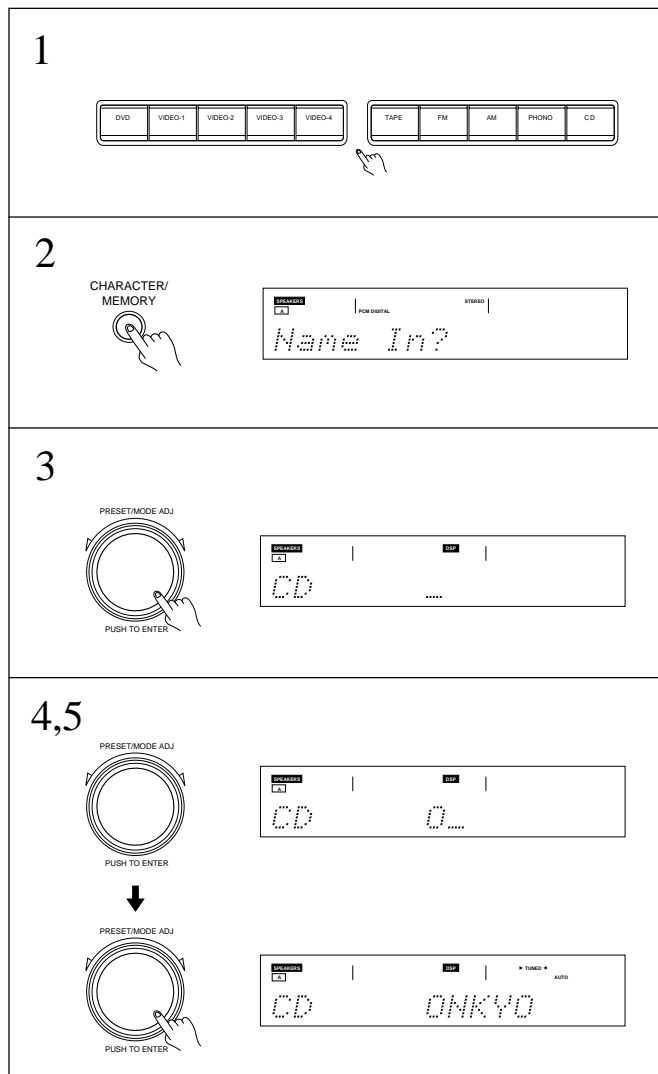

## Giving a name to each input source

You can give a desired name to each input source (DVD, CD, VIDEO 1-4, TAPE).

### Characters available for name entry

A B C D E F G H I J K L M N O P Q R S T U V W X Y Z a b c  
d e f g h i j k l m n o p q r s t u v w x y z ( ) < > [ ] & + - \* / = ? !  
; ; ' " . , 0 1 2 3 4 5 6 7 8 9 \_ ( \_ space)

1. **Select the source to which you wish to enter a name by pressing the corresponding input selector button.**
2. **Press the CHARACTER/MEMORY button.**  
"Name In ?" appears.
3. **Press the SMART SCAN CONTROLLER.**  
Now you can enter a name.
4. **Rotate the SMART SCAN CONTROLLER to select the character you wish to enter and then press the SMART SCAN CONTROLLER.**
5. **Enter a name of up to 8 characters.**  
The name entry mode will be canceled automatically when you finish entering 8 characters.  
If you enter a name of shorter than 8 characters, press the SMART SCAN CONTROLLER repeatedly until the initial display is restored.

### • To change a name...

1. **Select the source whose name you wish to change by pressing the corresponding input selector button.**
2. **Press the CHARACTER/MEMORY button.**  
"Name In ?" appears.
3. **Press the SMART SCAN CONTROLLER.**  
Now you can change the name.
4. **Press the TUNING DOWN/UP button to select the character you wish to change.**
5. **Rotate the SMART SCAN CONTROLLER to select the character you wish to enter and then press the SMART SCAN CONTROLLER.**  
The name entry mode will be canceled automatically when you finish entering 8 characters.

### • To erase a name...

1. **Select the source whose name you wish to erase by pressing the corresponding input selector button.**
2. **Press the CHARACTER/MEMORY button twice.**  
"Name Erase ?" appears.
3. **Press the SMART SCAN CONTROLLER.**  
"Erase OK ?" appears.  
If the name cannot be erased, press the CHARACTER/MEMORY button.
4. **Press the SMART SCAN CONTROLLER.**  
The entire name has been erased.

## Giving a name to each preset radio station

You can give a desired name to each preset radio station.

1. **Select the preset radio station to which you wish to enter a name.**  
Then, follow steps 2 through 5 of the above procedure "Giving a name to each input source" to give a name to each preset radio station.

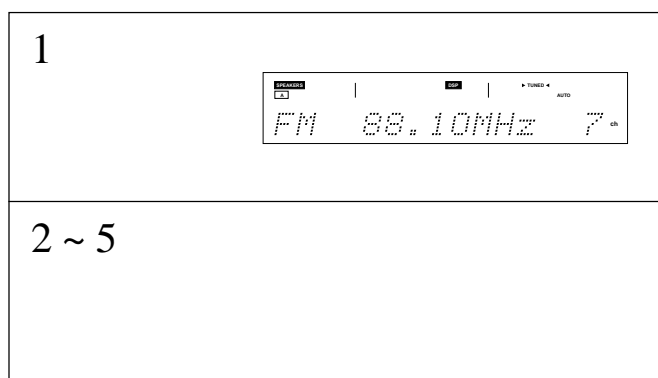

# Adjusting the output level of each speaker while listening to it

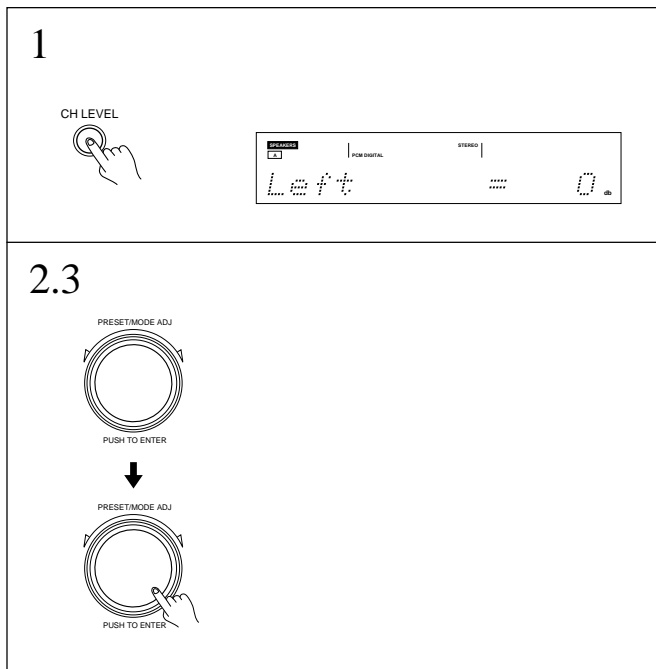

## Fine-tuning the output level of each speaker

You can fine-tune the output level of each speaker according to your taste.

The output levels you set as below will be lost once the unit is in stand-by mode. (The speaker levels you set using the test tone will be restored.)

### 1. Press the CH LEVEL button.

The output level of the Left front speaker is displayed.

### 2. Rotate the SMART SCAN CONTROLLER to select the output level and then press the SMART SCAN CONTROLLER.

You can now adjust the output level of the center speaker.

### 3. Repeat the operation described in step 2.

Set the speaker level of each speaker in the following sequence: Left (Left front) → Center → Right (Right front) → R-sur (Right surround) → L-sur (Left surround) → Subwoofer (Subwoofer)

You can adjust the output level of each speaker in the range of -12 to +12 dB.

The adjustment range of the subwoofer is -30 to +10 dB.

### To use the above setting from now on...

The above setting will be overwritten by the speaker output levels you set through the test tone, once you press the TEST button on the remote controller.

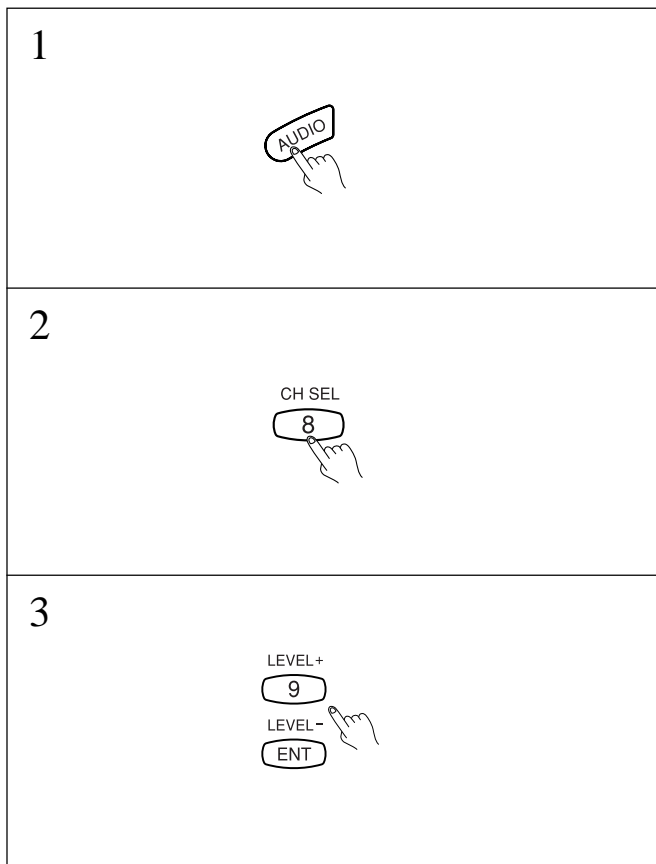

## Adjusting the output level of each speaker using the remote controller

### 1. Press the MODE AUDIO button.

### 2. Press the CH SEL button repeatedly to select the speaker whose output level you wish to fine-adjust.

Each time you press the CH SEL button, the output level of the speaker displayed is changed in the following sequence:

Left (Left front) → Center → Right (Right front) → R-sur (Right surround) → L-sur (Left surround) → Subwoofer (Subwoofer)

### 3. Press the LEVEL + or - button repeatedly to fine-adjust the output level.

You can adjust the output level of each speaker in the range of -12 to +12 dB.

The adjustment range of the subwoofer is -30 to +10 dB.

# Other setup operations

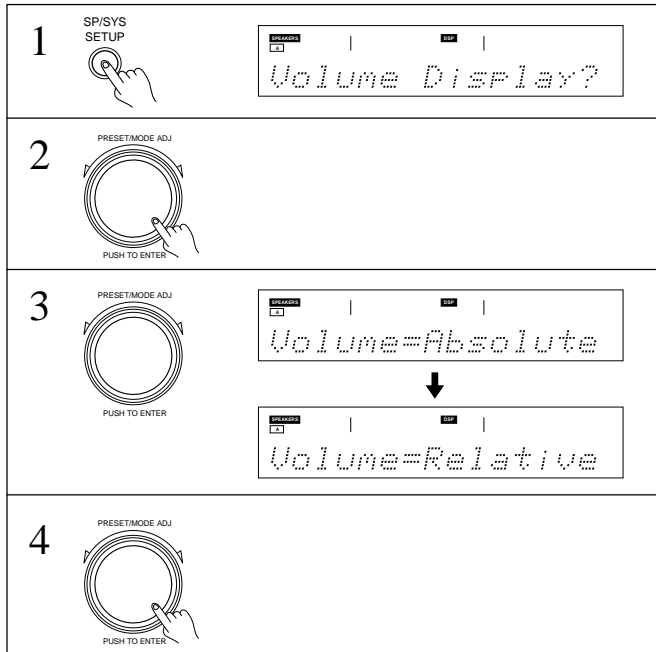

## Volume display method setup

You have the option of displaying your volume settings either of two ways:

- **ABSOLUTE** — on a scale of MIN (0: no sound) to MAX (80: maximum volume);
- or
- **RELATIVE** — on a scale which is measured “plus or minus,” relative to the calibrated reference volume.

With either settings, the volume level changes in the same increment.

ABSOLUTE: MIN, 1, 2, 3, 4, ....., 77, 78, 79, MAX

RELATIVE:  $-\infty$ , -61, -60, -59, ....., +16, +17, +18 (dB)

1. Press the SP/SYS SETUP button repeatedly until “Volume Display?” appears.
2. Press the SMART SCAN CONTROLLER.
3. Rotate the SMART SCAN CONTROLLER to select “Absolute” or “Relative.”
4. Press the SMART SCAN CONTROLLER.

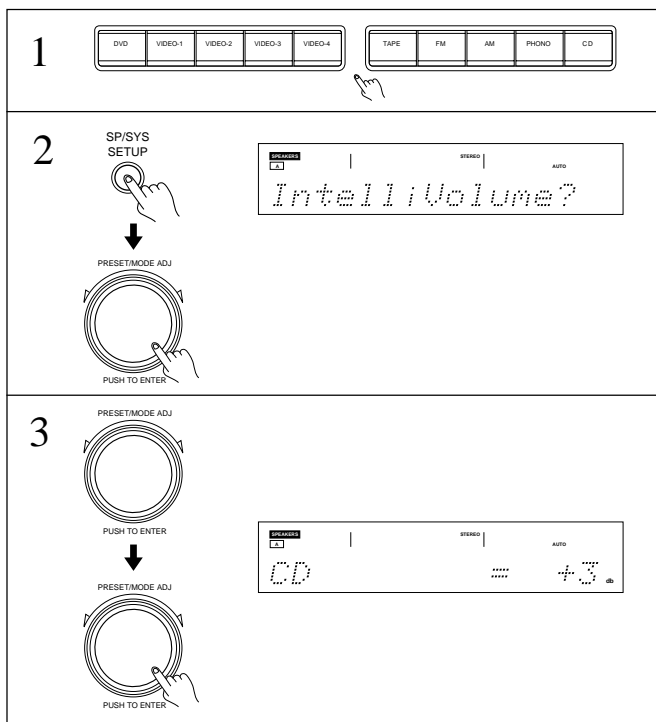

## IntelliVolume setup

The output level of each component or source connected to your receiver varies, even when the sound volume setting is same. You must therefore readjust the sound volume by yourself each time you change the input source, because the same volume setting causes too loud or too quiet sound. To prevent this inconvenience, you can set a correction value for each level of input source in advance.

1. Select the source to which you wish to set IntelliVolume by pressing the corresponding input selector button.
2. Press the SP/SYS SETUP button repeatedly until “IntelliVolume?” appears. Press the SMART SCAN CONTROLLER.

Now you can perform IntelliVolume setup.

3. While listening to playback sound, rotate the SMART SCAN CONTROLLER to select a desired value.

The setting is possible in the range between -12 / +12 dB, in units of 1 dB.

Press the SMART SCAN CONTROLLER.

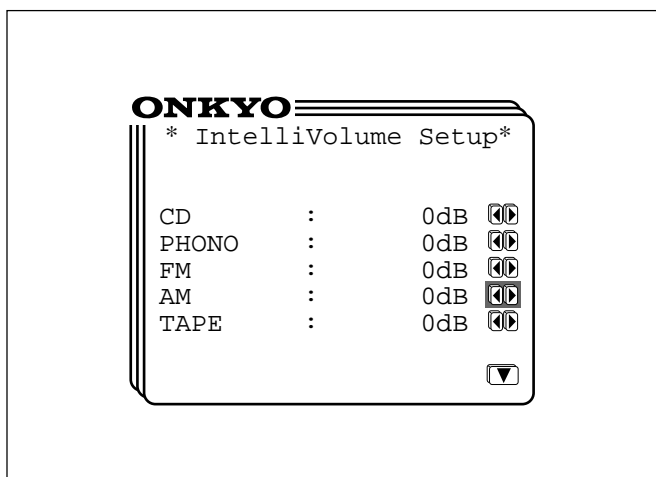

## Using the on-screen display

1. Press the OSD MENU button.
2. Select "Input Selector" and then press the right edge of the ENTER/Cursor button.
3. Select "IntelliVolume Setup" and then press the right edge of the ENTER/Cursor button.

The IntelliVolume Setup screen appears. When the cursor is on "TAPE," you can press the lower edge of the ENTER/Cursor button to display additional items.

4. Press the upper or lower edge of the ENTER/Cursor button to select the input source and then press the right or left edge of the button to select a value

Select a desired adjustment value for each input source. The setting is possible in the range between -12 / +12 dB, in units of 1 dB.

5. Press the center of the ENTER/Cursor button, or press the EXIT button, to exit the setup mode.

# Recording a source

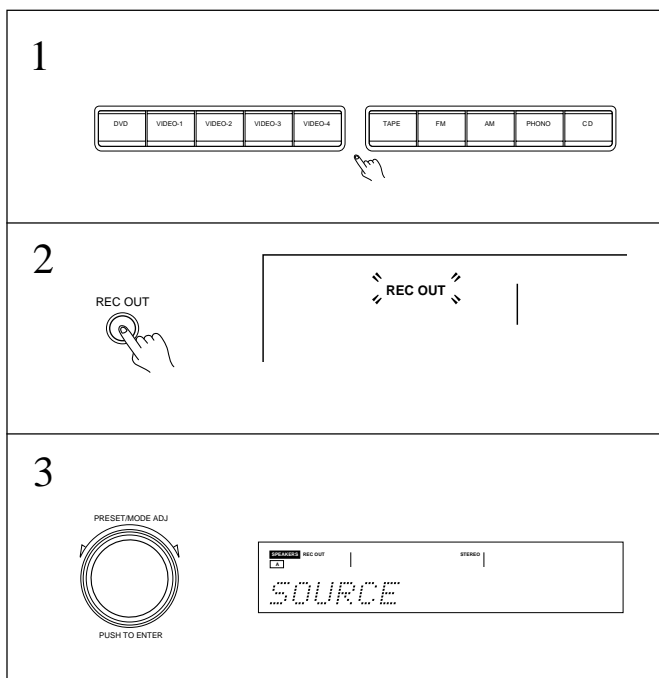
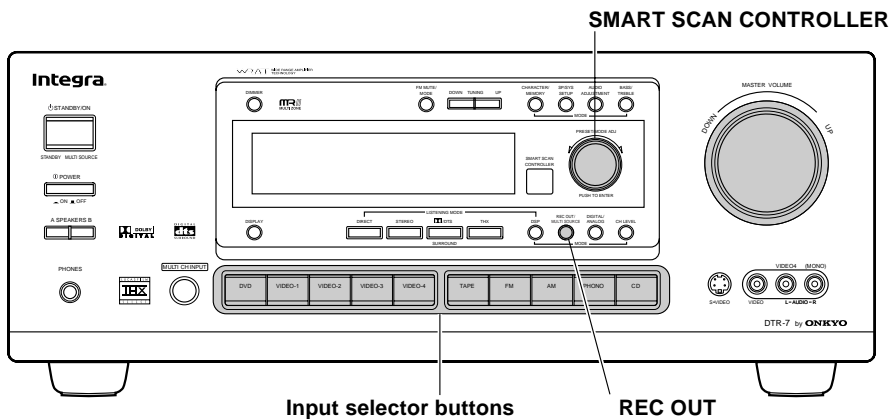

## Recording a source while listening to music or a movie

1. **Select the source you wish to play (recording source) by pressing the corresponding input selector button.**  
See step 1 of "Selecting an input source" (page 26).
2. **Press the REC OUT button.**  
The REC OUT indicator blinks for 8 seconds.  
While the REC OUT indicator is blinking, rotate the SMART SCAN CONTROLLER until "SOURCE" appears.

**Notes:**

- For DTR-7, The digital input signals assigned to the input source you selected using the input selector buttons will be output to the DIGITAL OUTPUT terminal. There are some restrictions on digital recording. When making digital recordings, consult the instruction manual that came with your digital recording equipment (such as MD recorder or DAT deck) to know what restrictions are imposed.
  - You cannot select the source connected to the MULTI CHANNEL INPUT connectors. Even if you press the MULTI CH INPUT button in step 1 above, the signals will be output to the L and R output jacks of the input source you selected most recently.
4. **Start recording on the recorder connected to the TAPE, VIDEO-1, VIDEO-2 jacks. Then, start playing the source component you selected in step 1.**

**Notes:**

- If you change the input source during recording, you will record the signals from the newly selected input source.
- You cannot record the surround effects.

## Recording from on audio /video source

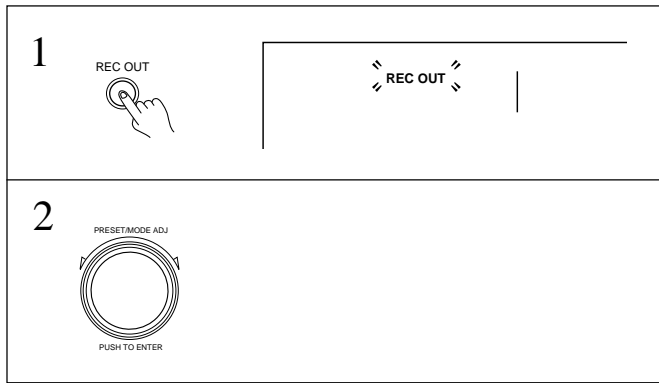

1. **Press the REC OUT button**  
The REC OUT indicator blinks for 8 seconds
2. **While the REC OUT indicator is blinking, rotate the SMART SCAN CONTROLLER to select the desired recording source.**

**Notes:**

- Selecting "SOURCE" sets the currently selected input source as the recording source.
  - For DTR-7, The digital input signals assigned to the input source you selected using the input selector buttons will be output to the DIGITAL OUTPUT terminal. There are some restrictions on digital recording. When making digital recordings, consult the instruction manual that came with your digital recording equipment (such as MD recorder or DAT deck) to know what restrictions are imposed.
  - You cannot select the source connected to the MULTI CHANNEL INPUT connectors. Even if you press the MULTI CH INPUT button in step 1 above, the signals will be output to the L and R output jacks of the input source you selected most recently.
3. **Start recording on the recorder connected to the TAPE, VIDEO-1, VIDEO-2 jacks. Then, start playing the source component you selected in step 1.**

**Notes:**

- If you change the input source during recording, you will record the signals from the newly selected input source.
- You cannot record the surround effects.

# Recording a source

1	
2	
3	
4	
5	
6	
7	
8	

## Adding sound to a video tape

You can add CD or MD sound to your video recordings. The following is an example of adding sound to a video recording using the video cassette recorder connected to the VIDEO-1 jacks of the receiver. Let's assume that you will record the images from a video camera connected to the VIDEO-4 VIDEO jack and the sound from a CD player.

1. Press the CD input selector button.
2. Press the SP/SYS SETUP button repeatedly until "Video Assign?" appears and then press the SMART SCAN CONTROLLER.
3. Rotate the SMART SCAN CONTROLLER until "VIDEO 4" appears. Press the SMART SCAN CONTROLLER.
4. Insert a CD in the CD player. Or, insert a tape in the video camera connected to the VIDEO-4 (VIDEO) jack.
5. Insert a tape to which recording is made in the video cassette recorder connected to the VIDEO-1 (R, L, V) jacks.
6. Press the REC OUT button.  
The REC OUT indicator blinks for 8 seconds.
7. Rotate the SMART SCAN CONTROLLER to select "SOURCE."
8. Start recording on the video cassette recorder connected to the VIDEO-1 jacks. Then, start playing the CD player and the video camera connected to the VIDEO-4 jack.

### Notes:

- If you change the input source during recording, you will record the audio signals from the newly selected input source and the video signals assigned to that input source.
- You cannot record the surround effects.

**ONKYO**

\*\* Rec Selector \*\*

• Picture	→ VIDEO	
=DVD	1, 2	
• Sound	→ TAPE	
=DVD	→ VIDEO	◀▶
	1, 2	
• Digital	OPTICAL	
=====	→ OUT	

### • Using the on-screen display

You can use the on-screen display to set the recording equipment to which the signals are output. By doing so, you can record signals from the selected input source.

1. Press the OSD MENU button.
2. Select "Rec Selector" and press the right edge of the ENTER/Cursor button.  
The Rec Selector screen appears.  
The recording sources are shown on the left and the corresponding output jacks are shown on the right.
3. Press the right or left edge of the ENTER/Cursor button to select the output jack.  
When Sound is set to "TAPE," "TUNER," "PHONE," or "CD," Picture shows the video source you set in "Assigning a video source to each audio input source" (see page 40).  
To record the currently playing sound or video images, select "(SOURCE)" below the source name for Sound or Picture.
4. Press the center of the ENTER/Cursor button, or press the EXIT button, to exit the setup mode.



# Using Multi-Room Remote System

## Outline of Multi-room Remote System

If you connect Onkyo Multi-room Remote System components as shown in the figure below, you can control the components from a sub-room as well as from the room where the DTR-7/DTR-6 is located. The Multi-Room Remote System allows remote operation when the A/V system is mounted in a cabinet or rack.

The following equipment (sold separately) is essential for using the Onkyo Multi-Room System:

- Onkyo's Multi-Room System kits HKT-600 or HKT-700 (IR Remote Controller Extension System), or
- Multiroom A/V distribution and control systems from Niles® and Xantech® to name a few

Make connection as shown below. Do not plug the equipment into the power source until the connection is complete.

## Enjoying Music and Movies in the Sub-room

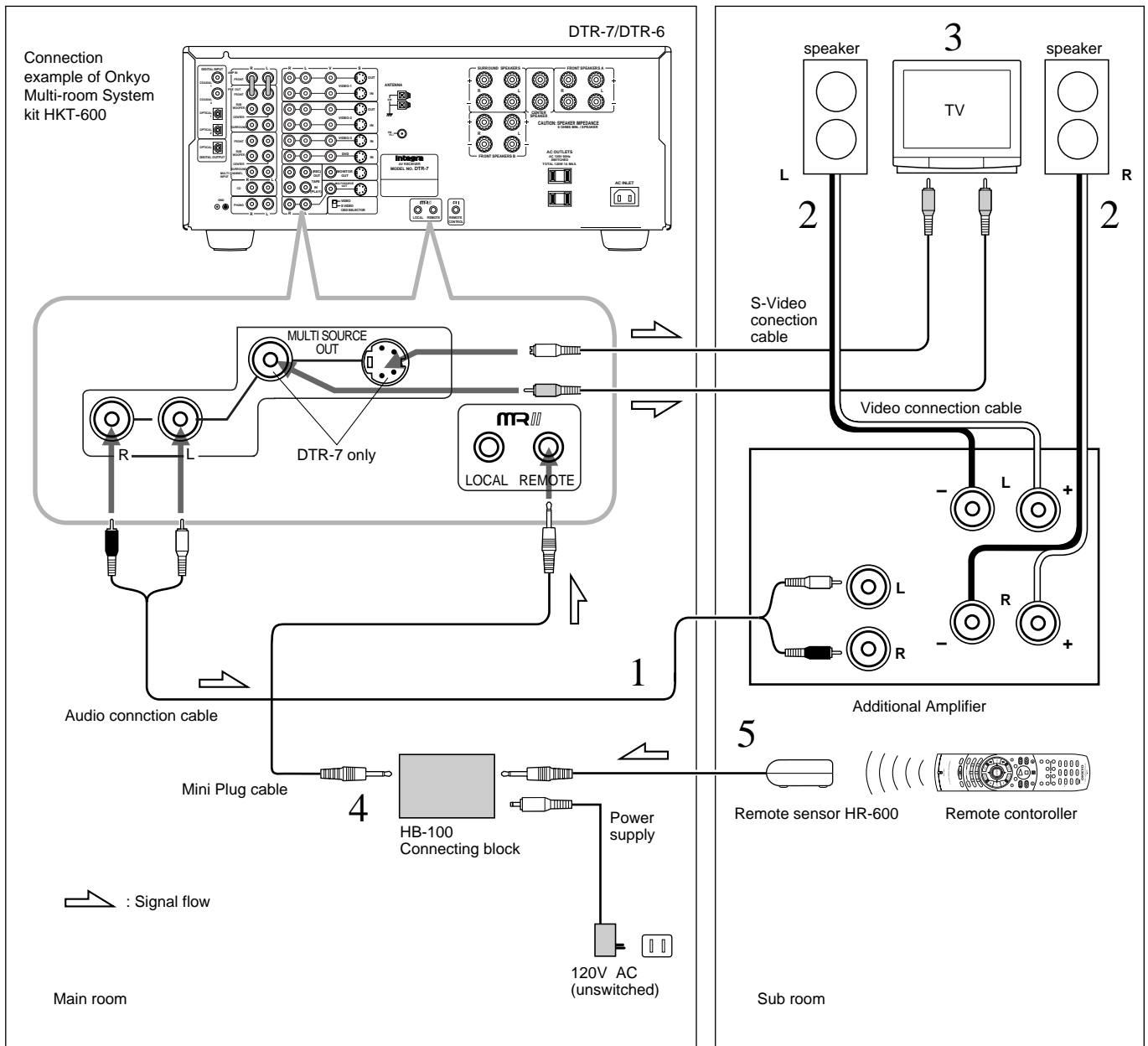

1. Connect the receiver to the power amplifier.
2. Connect the sub-room speaker cables to the speaker terminals on the power amplifier.
3. Connect the receiver to the TV.(DTR-7 only)
4. Install the Connecting block in the main room, then connect it to the REMOTE jack on the receiver.
5. Install the remote sensor in the sub-room, then connect it to the connecting block in the main room.

# Enjoying Music and Movies in the Sub-room

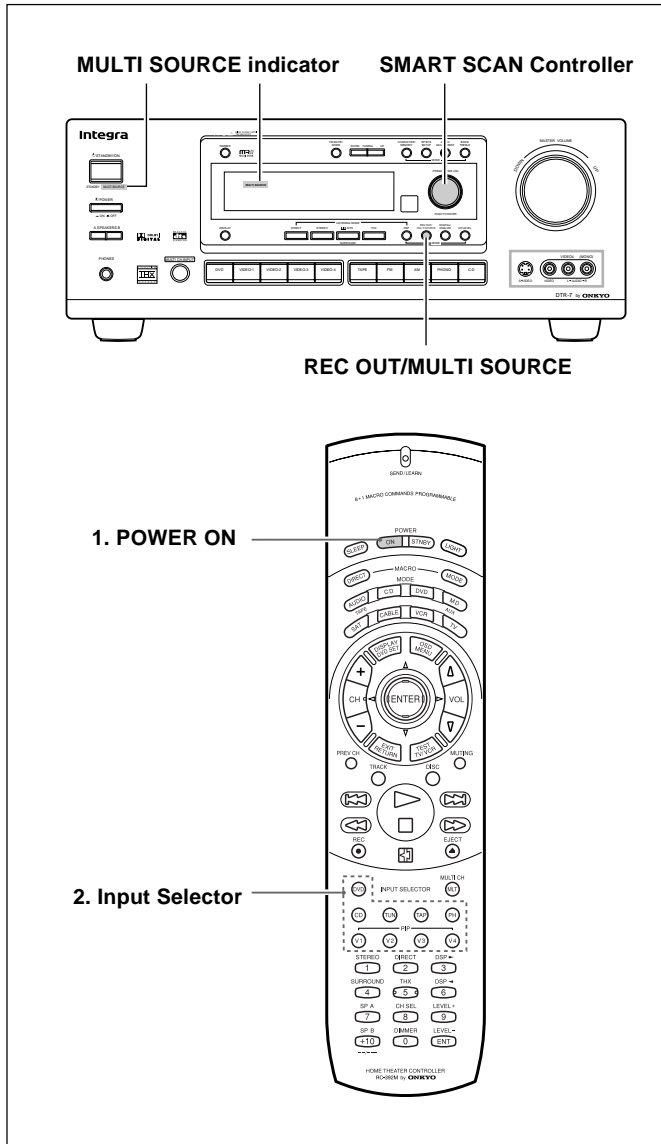

## To control the system in the sub-room

1. Press the **POWER ON** button on the remote controller. The **MULTI SOURCE** indicator located below the **STANDBY/ON** button on the receiver will light to indicate that the system enters the Multi-Source mode.

**Note:**  
If you operate the system in the sub-room while a recording is going on in the main-room, the source of the recording switches to the source which you are playing in the main room. Be careful when you are recording a different source from the one that you are playing.

2. Press the appropriate **Input Selector** button on the remote controller to select your desired source and start operating it.
3. Adjust the volume on the power amplifier to the desired level.

## To control the system using the main unit (e.g. when no remote controller is available):

1. Press the **REC OUT/MULTI SOURCE** button on the system to make sure the **MULTI SOURCE** indicator flashes in the display window.
2. Making sure that the indicator flashes, select a source by using the **Smart Scan Controller**. Adjust the volume in the sub-room.

- Notes:**
- In the sub-room, you can only play the source in the 2-Channel mode. You cannot play the source in the Multi-Channel mode or the Surround mode.
  - If you press the **REC OUT/MULTI SOURCE** button in the main room while you are playing the source in the Multi Source mode in the sub-room, the Multi Source function will be deactivated and the source will be inaudible in the sub-room.
  - Please note that some third-party multi-room system components may not be fully compatible with the Onkyo multi-room system components.

## When the system is mounted in a rack:

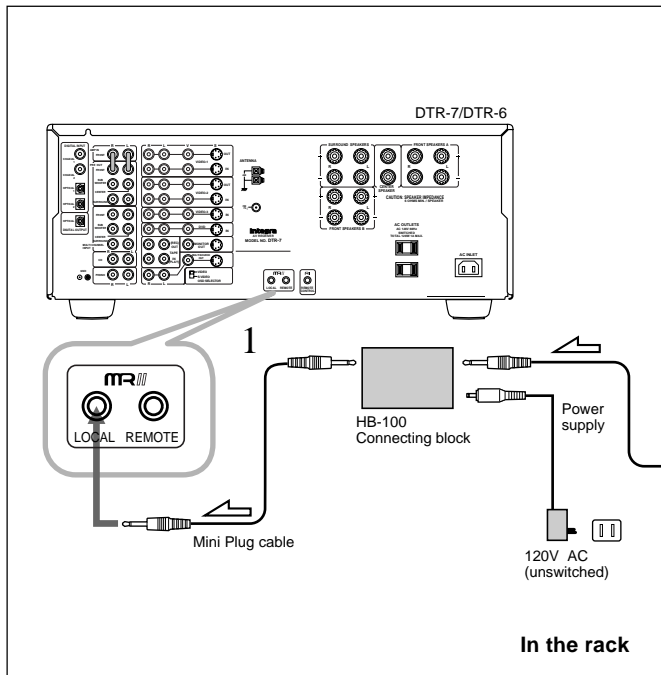

To enable remote operation when the receiver is mounted in a rack which will not permit infrared beams to pass, install the remote sensor at a location outside of the rack where the infrared beams from the controller can reach.

1. Connect the **LOCAL** jack (on the rear of the receiver) to the connecting block.
2. Install the remote sensor at a location where it can detect the infrared beams from the remote controller. Then, connect the remote sensor to the connecting block.

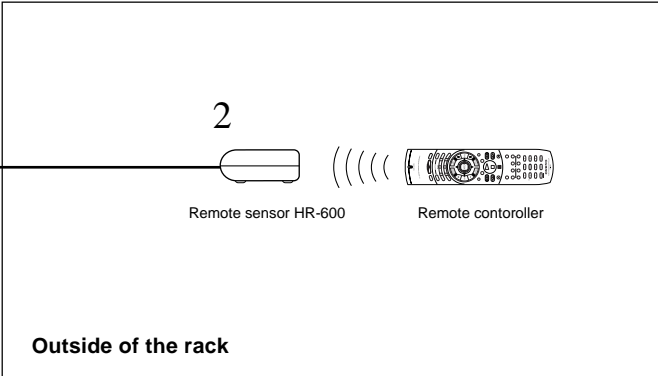

# The initial settings

The following table shows the factory-set default parameter values. Use it as a reference when you change these parameter values as needed, although they are usable in many cases.

Initial settings			
<b>Config Setup</b>		<b>Digital input</b>	
All Ch For THX	Yes	DVD	OPT2
	When set to "No"	VIDEO1	COAX1
	Subwoofer	VIDEO2	—(None)
	Front	VIDEO3	COAX2
	Center	VIDEO4	—(None)
	Surround	TAPE	—(None)
		CD	OPT1
<b>Distance Setup</b>		<b>Intellivolume</b>	
Left	3.6m/12ft	CD	0dB
Center	3.6m/12ft	PHONO	0dB
Right	3.6m/12ft	FM	0dB
R-Sur	2.1m/7ft	AM	0dB
L-Sur	2.1m/7ft	TAPE	0dB
Subwoofer	3.6m/12ft	DVD	0dB
<b>Speaker Level (Test tone)</b>		VIDEO1	0dB
Left	0dB	VIDEO2	0dB
Center	0dB	VIDEO3	0dB
Right	0dB	VIDEO4	0dB
R-Sur	0dB	<b>Video assign Setup</b>	
L-Sur	0dB	CD	—(None)
Subwoofer	0dB	PHONO	—(None)
<b>Listening mode</b>		FM	—(None)
Listening mode	stereo	AM	—(None)
<b>Listening mode parameter</b>		TAPE	—(None)
Re-EQ	ON when "THX" is selected	DVD	DVD
	OFF when "THX" is NOT selected	VIDEO1	VIDEO1
LATE NIGHT	OFF	VIDEO2	VIDEO2
LFE level	0dB	VIDEO3	VIDEO3
Front Effect	ON	VIDEO4	VIDEO4
Reflect level	0dB	<b>Tone Control</b>	
Reverb level	0dB	bass	0
Room size	Mid	treble	0
<b>Multi ch input</b>		<b>Screen Setup</b>	
Left	0dB	Background color	Blue1
Center	0dB	Superimpose	Normal
Right	0dB	Immediatedisplay	ON
R-Sur	0dB		
L-Sur	0dB		
Subwoofer	0dB		

# Using the remote controller

## Overview

When you use a remote controller, typically you press one of the MODE buttons that corresponds to the device you wish to control, then press the operation buttons. For example, if you wish to control the receiver from a remote controller, first press the MODE AUDIO button, then press an appropriate operation button. To control a CD player, press the MODE CD button, then press an appropriate operation button. First, press the desired MODE button to make sure that the receiver is set to a correct mode.

## Using the RC-392M to control each device

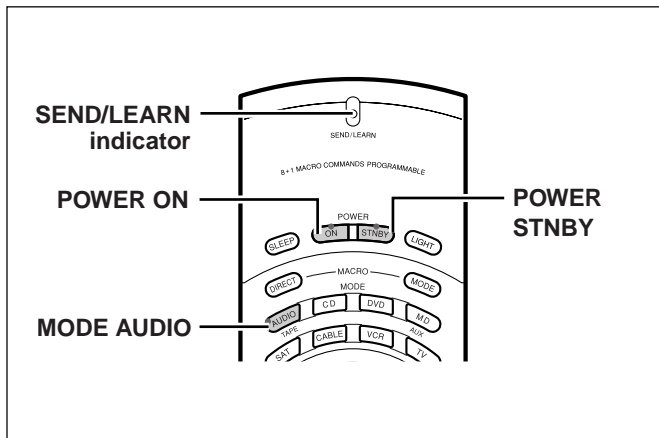

### Turning the power on and off to the receiver

#### Note:

Before operating the RC-392M, turn on the POWER switch on the receiver so that the unit enters standby mode.

1. Press the **MODE AUDIO** button.
2. Press the **POWER ON** button.

Pressing the POWER STNBY button will activate the power standby mode.

#### SEND/LEARN indicator

This indicator acts as a guide when commands are programmed into or sent by the remote controller. It also warns the user when an error is made or battery power is low.

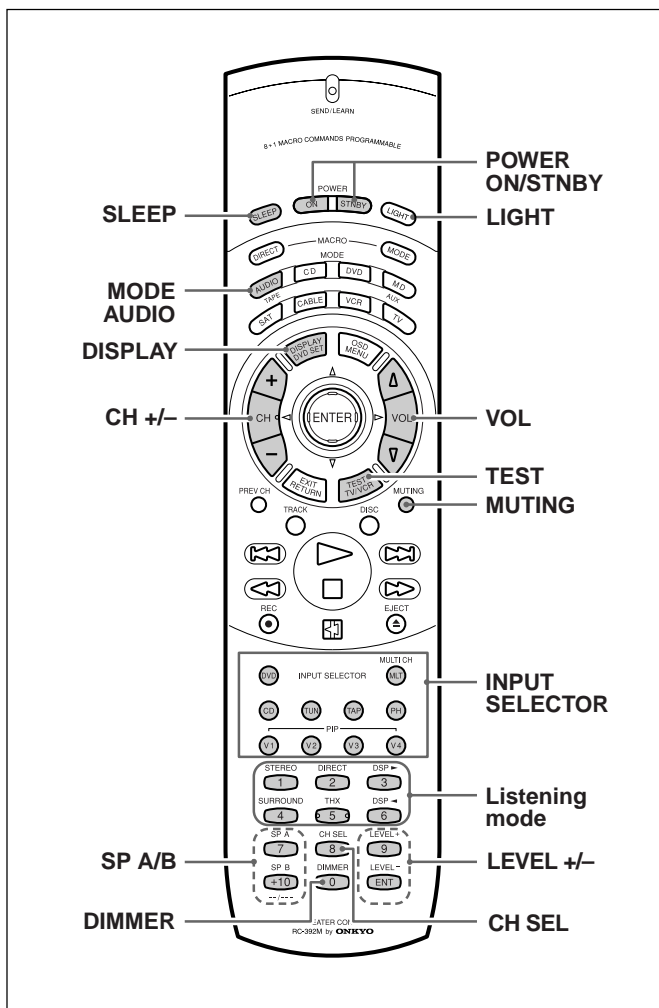

### Controlling the receiver

1. Press the **MODE AUDIO** button.
2. Press the desired operation button.

Shaded buttons in the figure are the operation buttons used to control the receiver.

**SLEEP** : Sleep function

**POWER ON/STNBY**

: Power on/standby

**DISPLAY** : Changing the display

**VOL Δ/∇** : Adjusting the volume

**CH +/-** : Tuner preset number increment/decrement

#### INPUT SELECTOR

#### Listening mode

: Changing Listening mode

**SP A/SP B** : Switching between Speakers A and B

**CH SEL** : Selecting a speaker

**DIMMER** : Adjusting the brightness of the display

**LEVEL +/-** : Adjusting the speaker levels

**TEST** : Test tone

**MUTING** : Muting

**LIGHT** : Illuminating the buttons.

# Using the remote controller

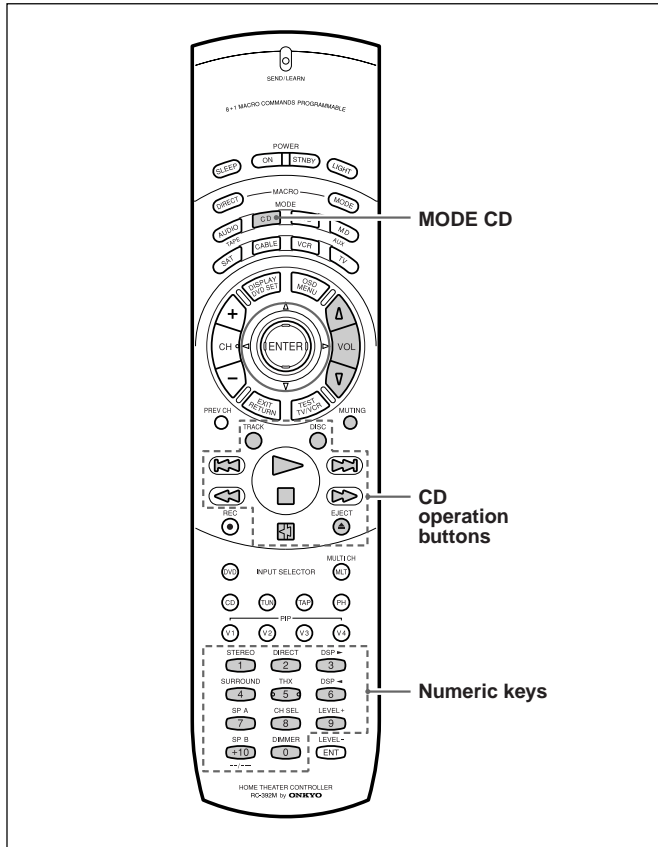

## Controlling an Onkyo/Integra CD player

**Note:**  
First connect an Onkyo/Integra CD player using the **R**I connection. (See page 7.)

1. Press the **MODE CD** button.
2. Press the desired **CD operation button**.

- TRACK** : Selecting a track
- DISC** : Selecting a disc in the CD changer
- : Down
- : Up
- : Playback
- : Stop
- : Rewind
- : Fast forward
- : Pause
- EJECT** : Eject
- 0, 1-9, +10** : Numeric keys

You may also use the following buttons:  
**VOL**  $\Delta/\nabla$  : Adjusting the volume level of the receiver  
**MUTING** : Muting the sound from the receiver

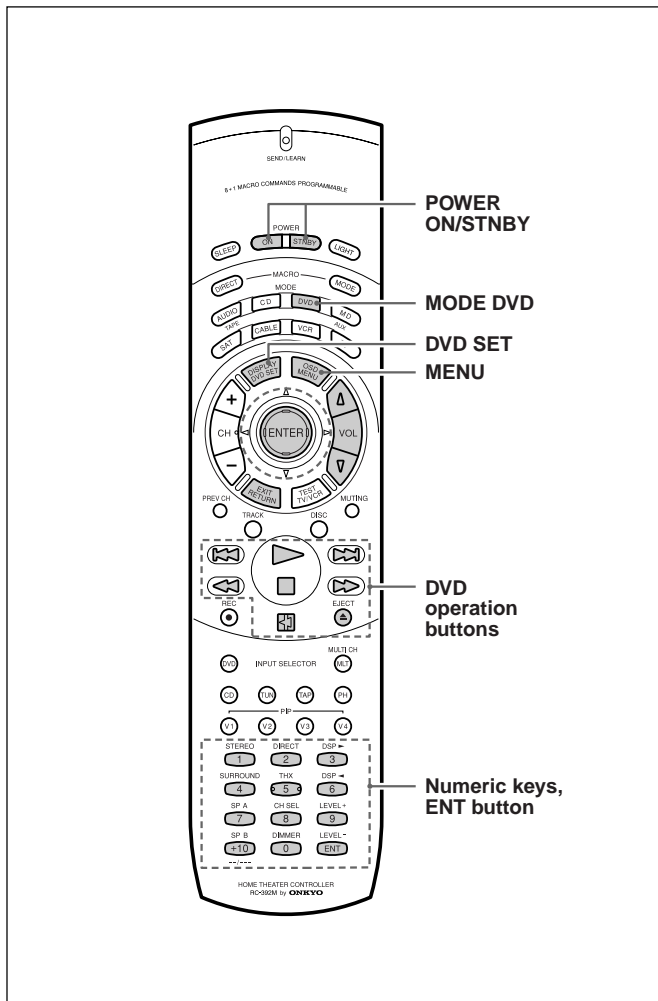

## Controlling an Onkyo/Integra DVD player

**Note:**  
Make sure that you point the transmission part on the remote controller toward the sensor area on the DVD player.

1. Press the **MODE DVD** button.
2. Press the desired **DVD operation button**.

- POWER ON/STNBY** : Turning the power on and off to the DVD player
- DVD SET** : DVD setup
- DVD player on-screen button**
- MENU** : Displaying the menu
- $\Delta\nabla\Delta\nabla$  : Moving the cursor
- ENTER** : Confirming the selection
- RETURN** : Return
- DVD player buttons**
- : Down
- : Up
- : Playback
- : Stop
- : Rewind
- : Fast forward
- : Pause
- EJECT** : Eject
- 0, 1-9, +10** : Numeric keys
- ENT** : Confirm

You may also use the following buttons:  
**VOL**  $\Delta/\nabla$  : Adjusting the volume level of the receiver  
**MUTING** : Muting the sound from the receiver

**Note:**  
The ENT button on the right below the numeric keys has the same function as "ENTER" of the ENTER/cursor button.

# Using the remote controller

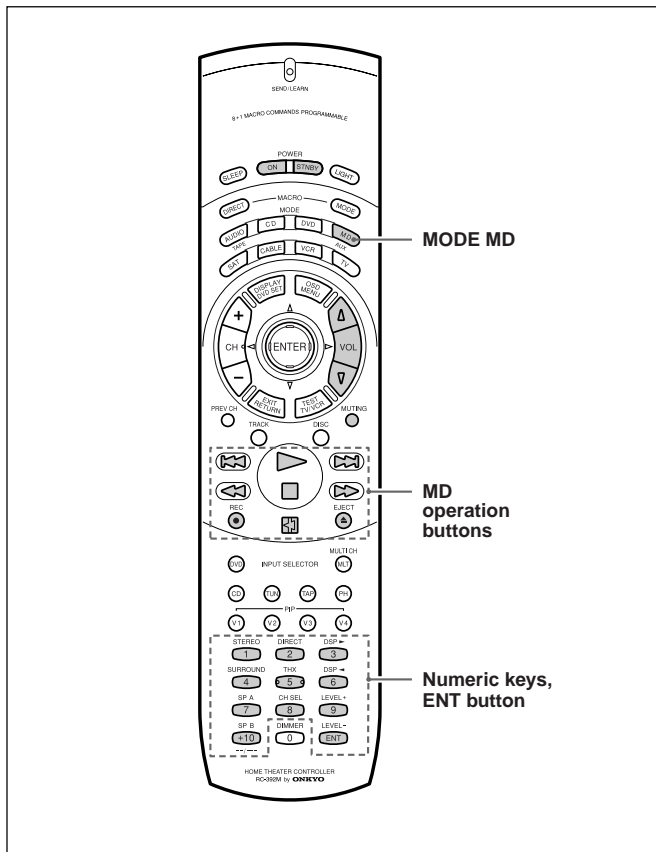

## Controlling an Onkyo/Integra MD recorder

**Note:**

Make sure that you point the transmission part on the remote controller toward the sensor area on the MD recorder.

1. Press the **MODE MD/AUX** button.
2. Press the **desired MD operation button.**

Turning the power on and off to the MD recorder

**POWER ON/STNBY**

: Turning on or standby the power to the MD recorder

: Down

: Up

: Playback

: Stop

: Rewind

: Fast forward

**REC** ● : Record

: Pause

**EJECT** ▲ : Eject

**1~9, +10** : Numeric keys

**ENT** : Confirm

You may also use the following buttons:

**VOL** Δ/∇ : Adjusting the volume level of the receiver

**MUTING** : Muting the sound from the receiver

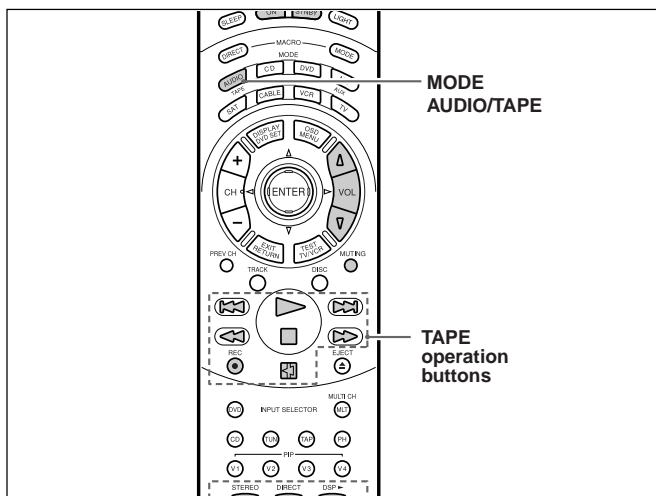

## Controlling an Onkyo/Integra tape deck

**Note:**

First connect an Onkyo/Integra tape deck using the **R** connection. (See page 7.)

1. Press the **MODE AUDIO/TAPE** button.
2. Press the **desired tape deck operation button.**

: Playback

: Stop

: Rewind

: Fast forward

**REC** ● : Recording/pause

: Reverse playback

You may also use the following buttons:

**VOL** Δ/∇ : Adjusting the volume level of the receiver

**MUTING** : Muting the sound from the receiver

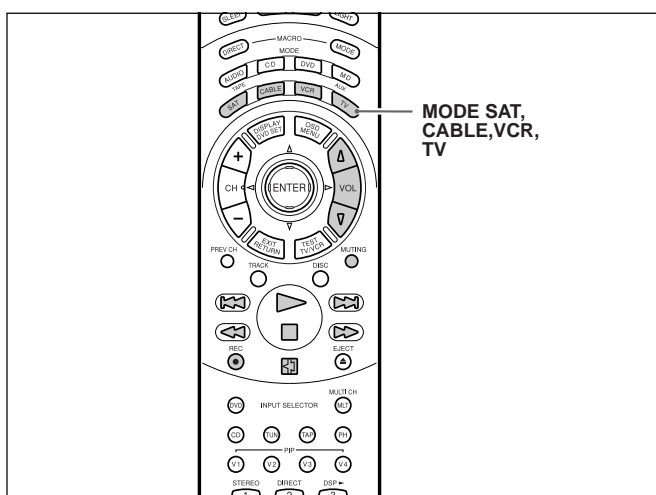

## MODE SAT, CABLE, VCR, and TV buttons

No preset codes are programmed into the MODE SAT, CABLE, VCR, and TV buttons. You can use these buttons to program remote controller signals of other devices. (See page 52.)

You may use the following buttons:

**VOL** Δ/∇ : Adjusting the volume level of the receiver

**MUTING** : Muting the sound from the receiver

# Programming the remote controller codes of other devices into the RC-392M

The RC-392M has two learning functions. One is a normal learning function that enables the RC-392M to learn other remote controllers' codes. The other is a macro learning function, which enables the RC-392M to learn a series of codes already memorized in the remote controller into one MACRO button.

## Programming procedure

Any button is programmable except for the eight Mode buttons (AUDIO, CD, DVD, MD, SAT, CABLE, VCR, and TV), two Macro buttons (DIRECT and MODE), and LIGHT button.

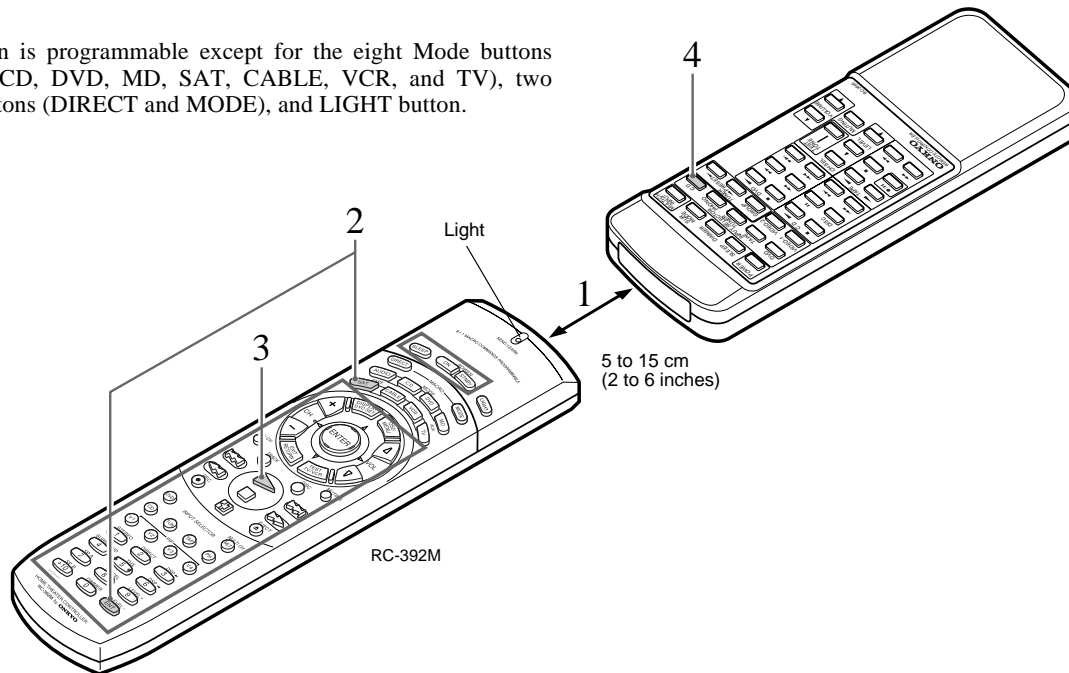

- 1. Place the RC-392M and the remote controller for another device, with 5–15cm (2–6 inches) apart and the light-emitting parts facing each other.**
- 2. While pressing and holding down the desired MODE button on the RC-392M (AUDIO, CD, DVD, MD, SAT, CABLE, VCR, or TV), press the ENT button, then release the buttons.**

When you press and hold down one of the MODE button, the SEND/LEARN indicator lights up. When you press the ENT button, the indicator turns off. When you release the buttons, the SEND/LEARN indicator lights up again.
- 3. Press and release the desired operation button on the RC-392M.**

You may select any button within the rectangle shown in the figure. When you press the button, the SEND/LEARN indicator turns off. When you release the button, the indicator lights up again.
- 4. Press and hold down the desired button on the remote controller of the other device until the SEND/LEARN indicator on the RC-392M flashes twice.**

The SEND/LEARN indicator flashes twice slowly, then lights up.
- 5. Repeat Steps 3 and 4 to program other buttons in the same MODE.**

Repeat Steps 2-4 to program other buttons in a different MODE.
- 6. Press the MODE button to complete programming.**
- 7. Operate the programmed button to make sure the learning function works.**

### Note:

The remote controller codes for the Onkyo/Integra CD player, tape deck, DVD player, and MD recorder have already been programmed into the buttons on the RC-392M. You may program other remote controller codes into these buttons. If you wish to restore the Onkyo/Integra preset codes after you program new codes, erase the new codes. (See page 53.)

### Notes:

- The remote controller can have max 408 memory slots (51 buttons by 8 modes), although this number varies significantly depending on the manufacturers and types of the remote controller you wish to program into the RC-392M. It is recommended that you determine which button functions have priority for programming.
- If you do not press any button for more than 30 seconds during the procedure, the SEND/LEARN indicator flashes three times quickly, then the RC-392M exits Learning mode. Resume from Step 2.
- If you make a mistake during programming, the SEND/LEARN indicator flashes three times quickly, then the RC-392M exits Learning mode.
- If you try to program beyond the learning capacity of the RC-392M, the SEND/LEARN indicator flashes six times quickly, then the RC-392M exits Learning function. Try programming in a button of other MODE.
- Follow the same procedure when you wish to program new codes into the already-programmed buttons.
- This remote controller uses infrared rays. Most remote controller codes can be memorized using the infrared system; however, depending on the degree to which the system differs, there may be some rare occasions when memorization is not possible.
- Some remote controllers use a single button to perform different functions, with the function code changing each time the button is pressed. If you are using this kind of controller, please perform the "learn" operations for each function individually to store each function to a button on the RC-392M.
- For instructions regarding the operation of "learned" units, please refer to the instruction manual for each product.
- Even after codes have been memorized, please keep your old remote controller in a safe place. If the memorized codes are lost when the batteries run down, it will be necessary to memorize them once again using the old remote controller.
- Make sure both the RC-392M and the product's own remote controller have fresh batteries. If either of them has batteries that are wearing down, it may be impossible to store the remote controller codes into the RC-392M or the product may not respond properly to the buttons on the RC-392M for which the remote controller codes were stored into memory.



# Programming the remote controller codes of other devices into the RC-392M

See page 57 for information on how to erase the learned codes from all buttons.

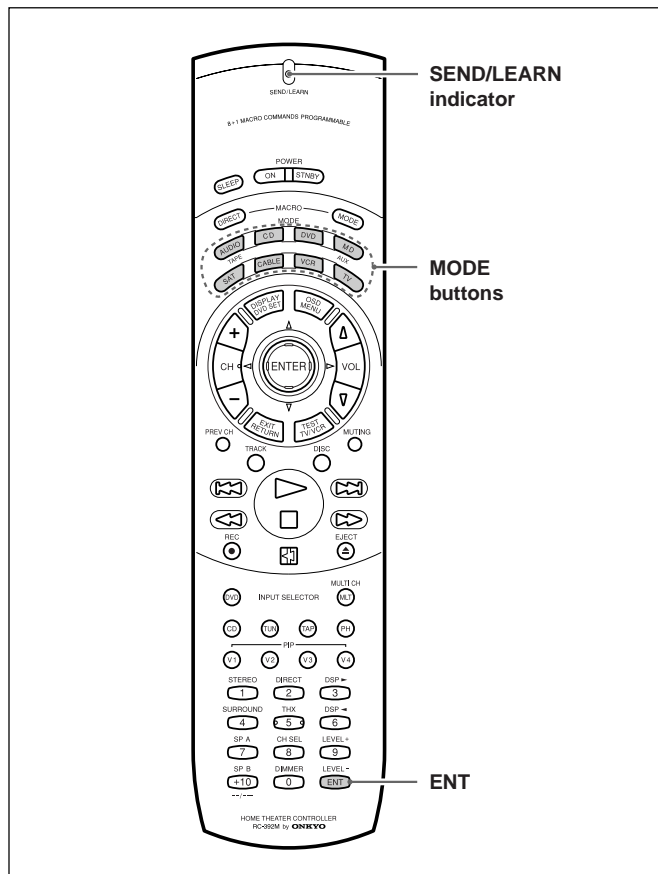

## Erasing a learned code

You can erase a learned code. You cannot erase preset codes.

### •Erasing a code programmed in a button

- 1. Press and hold down the corresponding MODE button and press the ENT button, then release the buttons.**  
When you press the MODE button, the SEND/LEARN indicator lights up. When you press the ENT button, the indicator turns off. When you release the buttons, the indicator lights up again.
- 2. Press and release the button from which you wish to erase the learned code.**  
When you press the button, the SEND/LEARN indicator turns off. When you release the button, the indicator lights up again.
- 3. Press and release the same button again.**  
The SEND/LEARN indicator flashes twice slowly. The learned code is erased.

### Note:

If you do not press the button in step 2 or 3 for more than 30 seconds, the SEND/LEARN indicator flashes three times quickly, then the RC-392M exits Learning mode. Resume from Step 1.

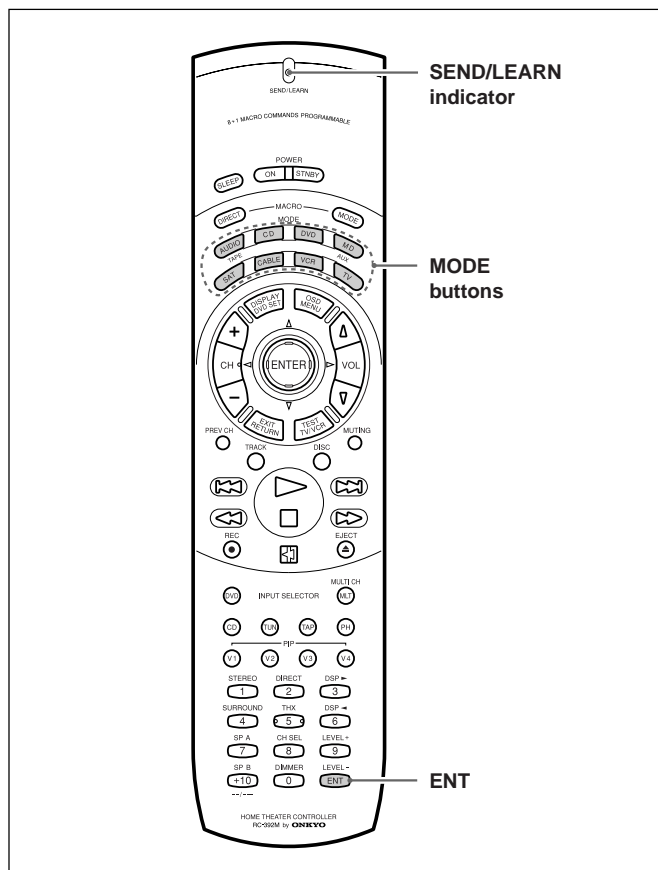

## Erasing a learned code from a MODE button

- 1. Press and hold down the MODE button from which you wish to erase the learned code, and press the ENT button twice. Then release the buttons.**  
When you press the MODE button, the SEND/LEARN indicator lights up. When you press the ENT button, the indicator turns off. When you release the buttons, the indicator flashes twice slowly, then lights up again.
- 2. Press and release the same MODE button again.**  
When you release the button, the SEND/LEARN indicator flashes twice slowly. The learned code is erased.

### Note:

- If you do not press any button for more than 30 seconds, the SEND/LEARN indicator flashes three times quickly, then the RC-392M exits Learning mode. Resume from Step 1.
- If you make a mistake during programming, the SEND/LEARN indicator flashes three times quickly, the RC-392M exits Learning mode. Resume from Step 1.
- If you have programmed many button operations to a single MODE button, the SEND/LEARN indicator may remain illuminated continuously in Step 2. This is not malfunction.



# Using a Macro function

## What is a Macro function?

A Macro function enables you to program a series of button operations into a single button on the remote controller. For example, you need to follow the steps below to play a CD player connected to the receiver without using the Macro function:

1: Press the MODE AUDIO button. → 2: Press the POWER ON button. → 3: Press the CD (INPUT SELECTOR) button. → 4: Press the MODE CD button. → 5: Use the numeric keys to select the desired song.

This operation will be two button presses away if you program these steps into a macro button.

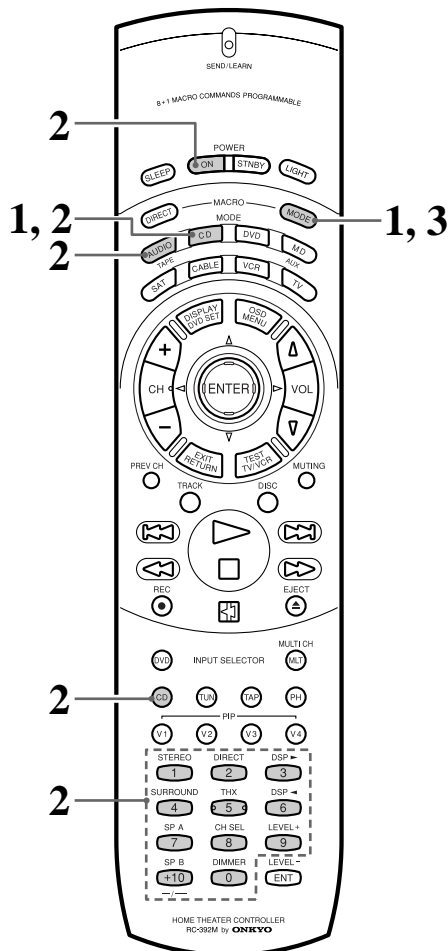

### Tip:

The codes programmed into a MACRO button will be transmitted with an interval of 0.5 seconds. However, some devices may not be able to complete one operation in 0.5 seconds and may miss the next code. In this case, press one operation button, press the corresponding MODE button, then press another operation button to extend the interval between the two operations up to one second.

## Programming Macro mode

You may program the desired steps into each of eight MODE buttons. The following example explains how to program Steps 1–5 (described above) into the MACRO MODE button under the MODE CD button (CD mode).

**1. Press and hold down the desired MODE button you wish to program (in this case, MODE CD button), and press the MACRO MODE button. Then release the buttons.**

When you press the MODE CD button, the SEND/LEARN indicator lights up. When you press the MACRO MODE button, the indicator turns off.

When you release the buttons, the indicator flashes briefly, then lights up again.

**2. Press the operation buttons in series you wish to program into the MACRO MODE button.**

Press the MODE AUDIO, POWER ON, CD (INPUT SELECTOR), MODE CD buttons, and a numeric button. When you press the button, the SEND/LEARN indicator turns off. When you release the button, the indicator lights up.

**3. Press the MACRO MODE button to complete programming.**

The SEND/LEARN indicator flashes twice slowly.

Repeat Steps 1–3 to program other series of button operations into another MODE button.

**4. Check to see if the series of button operation has been correctly learned.**

Point the remote controller toward the receiver, press the MODE CD button, and press the MACRO MODE button to see if the unit responds as programmed.

Transmitting the codes in Macro mode takes a while. During transmission, point the remote controller toward the device to be controlled.

### Notes:

- You may program up to 16 button operations into each MACRO button. If you try to program the 17th step, it will be ignored.
- If you do not press any button for more than 30 seconds during the procedure, the SEND/LEARN indicator flashes three times quickly, then the RC-392M exits Learning mode. Resume from Step 1.
- If you make a mistake during programming, the SEND/LEARN indicator flashes three times quickly, then the RC-392M exits Learning mode. Resume from Step 1.
- If you cancel one of the operation already programmed in the MACRO MODE button, or if you program a different code into such a button, the operation button will no longer work. In this case, program the buttons again to avoid malfunction.

# Using a Macro function

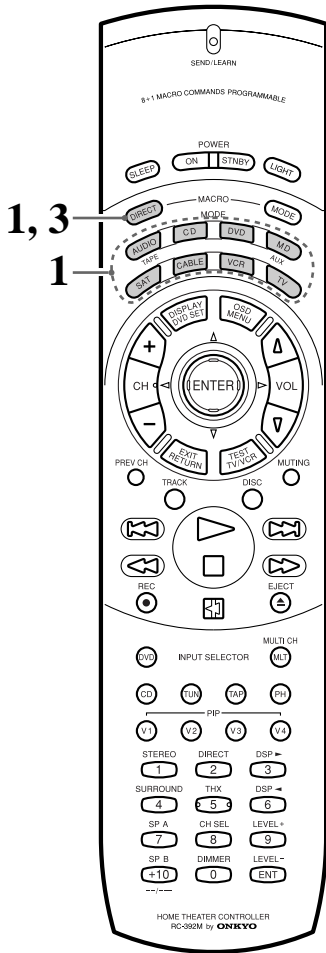

**Tip:**  
The codes programmed into a MACRO button will be transmitted with an interval of 0.5 seconds. However, some devices may not be able to complete one operation in 0.5 seconds and may miss the next code. In this case, press one operation button, press the corresponding MODE button, then press another operation button to extend the interval between the two operations up to one second.

## Macro Direct Learning function

A series of remote controller button operations can be memorized into the MACRO DIRECT button for one-touch control.

**Note:**  
You can program only one series of button operations into the MACRO DIRECT button.

**1. Press and hold down any one of the eight MODE buttons and press the MACRO DIRECT button. Then, release the buttons.**

When you press the MODE button, the SEND/LEARN indicator lights up. When you press the MACRO DIRECT button, the indicator turns off. When you release the buttons, the indicator flashes briefly, then lights up again.

**2. Follow Step 2 in the “Programming Macro Mode” on page 54.**

**3. Press the MACRO DIRECT button to complete the procedure.**

The SEND/LEARN indicator flashes twice slowly.

**4. Check to see if the button has been programmed correctly.** Point the RC-392M toward the receiver and press the MACRO DIRECT button, and make sure that the device responds as programmed.

Transmitting the codes in Macro mode takes a while. During transmission, point the remote controller toward the device to be controlled.

- Notes:**
- You may program up to 16 button operations into the MACRO DIRECT button. If you try to program the 17th step, it will be ignored.
  - If you do not press any button for more than 30 seconds during the procedure, the SEND/LEARN indicator flashes three times quickly, then the RC-392M exits Learning mode. Resume from Step 1.
  - If you make a mistake during programming, the SEND/LEARN indicator flashes three times quickly, then the RC-392M exits Learning mode. Resume from Step 1.
  - If you cancel one of the operation already programmed in the MACRO DIRECT button, or if you program a different code into such a button, the operation button will no longer work. In this case, program the buttons again to avoid malfunction.

## Using a Macro function

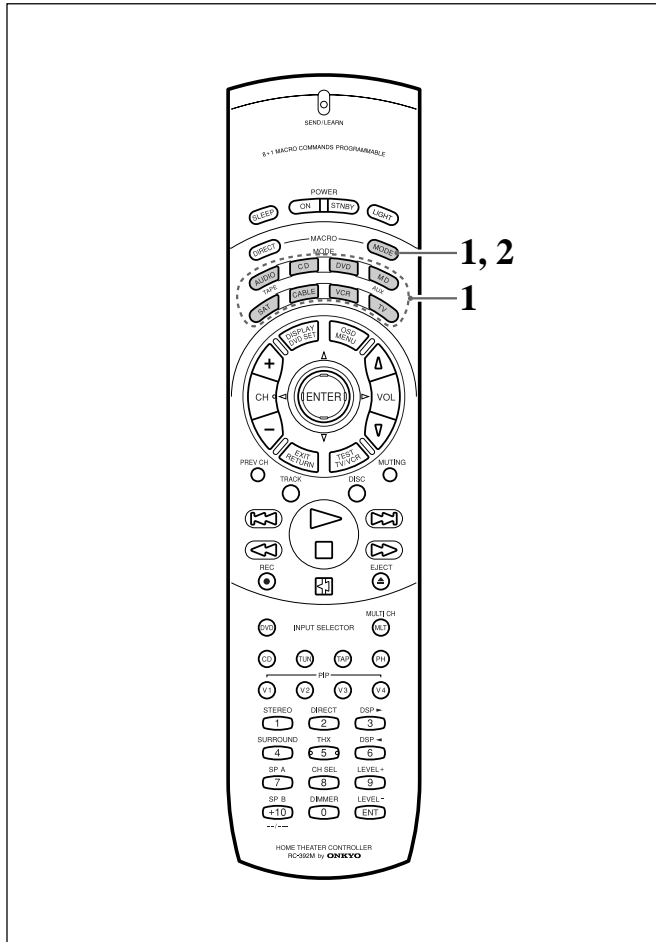

### Erasing a learned remote controller button operation from the MACRO MODE buttons

1. **Press and hold down the corresponding MODE button and press the MACRO MODE button, then release the buttons.** When you press the MODE button, the SEND/LEARN indicator lights up. When you press the MACRO MODE button, the indicator turns off. When you release the buttons, the indicator flashes once.
2. **Press the MACRO MODE button again.** The SEND/LEARN indicator flashes twice slowly. The learned operation is erased.

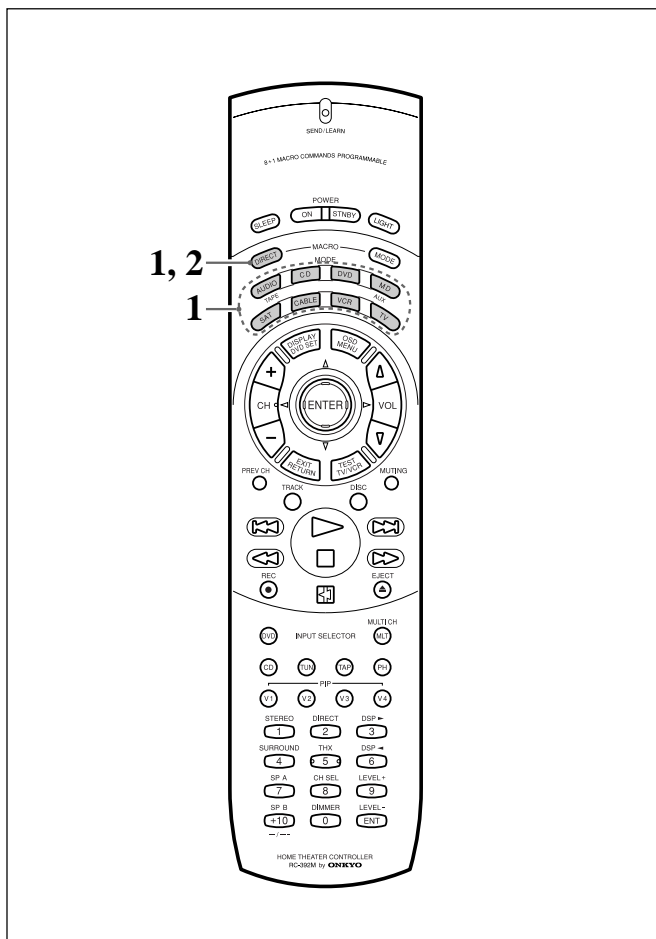

### Erasing a learned remote controller button operation from the MACRO DIRECT button

1. **Press and hold down any one of the MODE buttons and press the MACRO DIRECT button. Then release the buttons.** When you press the MODE button, the SEND/LEARN indicator lights up. When you press the MACRO DIRECT button, the indicator turns off. When you release the buttons, the indicator flashes once.
2. **Press the MACRO DIRECT button again.** The SEND/LEARN indicator flashes twice slowly. The learned operation is erased.

#### Notes:

- If you do not press any button for more than 30 seconds, the SEND/LEARN indicator flashes three times quickly, then the RC-392M exits Learning mode. Resume from Step 1.
- If you press a wrong button in Step 2, you may have overwritten the memory of the button you pressed.

## Using a Macro function

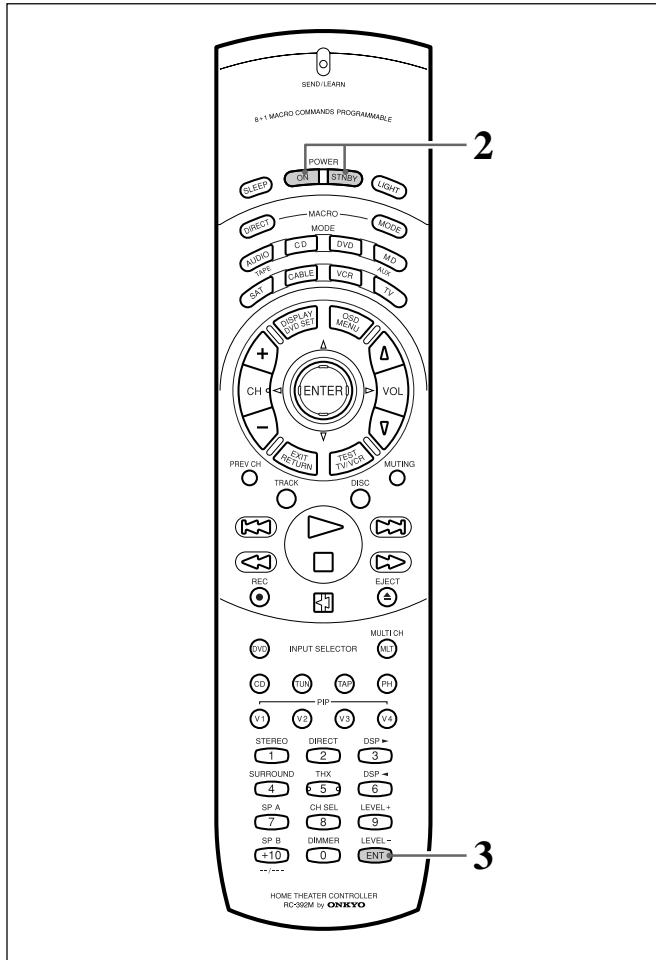

### Erasing all codes and operations programmed in the buttons

This procedure will erase all remote controller codes for the other devices and all macro operations that have been programmed in the RC-392M (see pages 52, 54 and 55).

1. **Open the battery cover and remove the batteries.**
2. **While pressing and holding down the POWER ON button and the POWER STNBY button, insert the batteries in the correct direction.**

After inserting the batteries, release the buttons. The SEND/LEARN indicator flashes slowly.

3. **Press the ENT button.**

The SEND/LEARN indicator lights up for about ten seconds, then turns off.

All programmed codes are erased and the button memories return to the factory presets.

#### Notes:

- Proceed to Step 3 immediately once you have completed Step 2. Otherwise, the batteries will be consumed quickly.
- If you press any button other than the ENT button in Step 3, no codes will be erased. In this case, repeat the steps from the beginning.

# Troubleshooting guide

If a problem occurs while you are using the remote controller, first try to operate the front panel controls on the main unit to make sure that it is not due to a malfunction (or worn out batteries) in the remote controller.

Trouble	Cause	Remedy	See page
<b>POWER</b>			
Power shut off immediately after power on.	<ul style="list-style-type: none"> <li>Amplifier protection circuitry has been activated.</li> </ul>	<ul style="list-style-type: none"> <li>Remove the AC plug from the outlet immediately. Then contact your Onkyo service center.</li> </ul>	-
No power.	<ul style="list-style-type: none"> <li>Power cord is disconnected.</li> </ul>	<ul style="list-style-type: none"> <li>Connect power cord.</li> </ul>	13
	<ul style="list-style-type: none"> <li>There is external noise in the computer circuits of this unit.</li> </ul>	<ul style="list-style-type: none"> <li>Turn the power button off and then on again or remove the AC plug from the outlet and then plug it again.</li> </ul>	13
	<ul style="list-style-type: none"> <li>AC fuse blown.</li> </ul>	<ul style="list-style-type: none"> <li>Contact your Onkyo Service Center.</li> </ul>	-
Power on but no sound.	<ul style="list-style-type: none"> <li>"Muting" is displayed.</li> </ul>	<ul style="list-style-type: none"> <li>Press the MUTING button on the remote controller to turn it off.</li> </ul>	31
	<ul style="list-style-type: none"> <li>The digital/analog input setting is incorrect.</li> </ul>	<ul style="list-style-type: none"> <li>Select the correct input.</li> </ul>	23,29
	<ul style="list-style-type: none"> <li>Bad connections.</li> </ul>	<ul style="list-style-type: none"> <li>Check connections, speaker leads, etc.</li> </ul>	6-15
	<ul style="list-style-type: none"> <li>Amplifier protection circuitry has been activated.</li> </ul>	<ul style="list-style-type: none"> <li>Contact your Onkyo Service Center.</li> </ul>	-
The sound of the playback source is not heard.	<ul style="list-style-type: none"> <li>The input selector is not set properly.</li> </ul>	<ul style="list-style-type: none"> <li>Set it to the playback source.</li> </ul>	26,27
No picture appears on the TV screen (or monitor)	<ul style="list-style-type: none"> <li>The TV (or monitor) is not set to receive the output signals from the receiver.</li> </ul>	<ul style="list-style-type: none"> <li>Set the TV (or monitor) to the receiver input.</li> </ul>	8
	<ul style="list-style-type: none"> <li>The video cable is not connected securely.</li> </ul>	<ul style="list-style-type: none"> <li>Check the connections.</li> </ul>	8
	<ul style="list-style-type: none"> <li>Only S video connection is made.</li> </ul>	<ul style="list-style-type: none"> <li>Make also video connection.</li> </ul>	8
<b>SPEAKERS</b>			
No sound from the center speaker, or very minimal sound.	<ul style="list-style-type: none"> <li>Speaker cable is not connected.</li> </ul>	<ul style="list-style-type: none"> <li>Check the connection between the amplifier and the speaker.</li> </ul>	11
	<ul style="list-style-type: none"> <li>Listening mode is set to Stereo or Direct.</li> </ul>	<ul style="list-style-type: none"> <li>Set the Listening mode to any mode other than Stereo or Direct.</li> </ul>	34-38
	<ul style="list-style-type: none"> <li>CENTER level is set to minimum.</li> </ul>	<ul style="list-style-type: none"> <li>Set the CENTER level to the appropriate volume.</li> </ul>	21
	<ul style="list-style-type: none"> <li>CENTER SPEAKER is set to None.</li> </ul>	<ul style="list-style-type: none"> <li>Set CENTER SPEAKER to Large or Small.</li> </ul>	18,19
No sound or quiet sound from subwoofer	<ul style="list-style-type: none"> <li>Subwoofer is set to No.</li> </ul>	<ul style="list-style-type: none"> <li>Check the speaker setting.</li> </ul>	12
	<ul style="list-style-type: none"> <li>Subwoofer speakers output level setting is improper.</li> </ul>	<ul style="list-style-type: none"> <li>Check the output level of the Subwoofer using the test tone.</li> </ul>	22
<b>PHONO</b>			
Hum, low-frequency noise.	<ul style="list-style-type: none"> <li>Poor or no input ground.</li> </ul>	<ul style="list-style-type: none"> <li>Check outer conductor of input plugs.</li> </ul>	6
	<ul style="list-style-type: none"> <li>Poor or no phono motor ground.</li> </ul>	<ul style="list-style-type: none"> <li>Check for proper ground connection.</li> </ul>	6
	<ul style="list-style-type: none"> <li>The placement of the audio connection cables on the rear panel is incorrect.</li> </ul>	<ul style="list-style-type: none"> <li>Adjust the placement of the cable to reduce hum.</li> </ul>	-
Howling when the volume is turned up.	<ul style="list-style-type: none"> <li>Turntable and speakers are too close together.</li> </ul>	<ul style="list-style-type: none"> <li>Move them farther apart.</li> </ul>	-
Rough or scratchy sound. High range is not clear.	<ul style="list-style-type: none"> <li>Stylus of turntable pick-up is worn.</li> </ul>	<ul style="list-style-type: none"> <li>Replace.</li> </ul>	-
	<ul style="list-style-type: none"> <li>Turntable stylus tip is dirty.</li> </ul>	<ul style="list-style-type: none"> <li>Clean.</li> </ul>	-
	<ul style="list-style-type: none"> <li>Treble control too high.</li> </ul>	<ul style="list-style-type: none"> <li>Turn treble control down.</li> </ul>	31
<b>FM/AM</b>			
AM stations cannot be received.	<ul style="list-style-type: none"> <li>AM loop antenna is not attached.</li> </ul>	<ul style="list-style-type: none"> <li>Connect the included AM loop antenna to the AM antenna terminals.</li> </ul>	14
Buzzing noise on AM (particularly conspicuous at night or with weak stations).	<ul style="list-style-type: none"> <li>Noise from electrical apparatus such as fluorescent lamp.</li> </ul>	<ul style="list-style-type: none"> <li>Move the AM loop antenna to different position.</li> </ul>	15
		<ul style="list-style-type: none"> <li>Set up an outdoor AM antenna.</li> </ul>	15
High-pitched noise or buzzing noise on AM.	<ul style="list-style-type: none"> <li>Noise from TV set.</li> </ul>	<ul style="list-style-type: none"> <li>Place the AM loop antenna as far as possible from the TV.</li> </ul>	15
		<ul style="list-style-type: none"> <li>Move unit away from TV set.</li> </ul>	-
Crackling noise on AM, FM.	<ul style="list-style-type: none"> <li>Noise caused by turning fluorescent lamp on and off.</li> <li>Noise from automobile ignition.</li> </ul>	<ul style="list-style-type: none"> <li>Move antenna as far as possible from the fluorescent lamp.</li> </ul>	15
		<ul style="list-style-type: none"> <li>Install an FM outdoor antenna as far as possible from the road.</li> </ul>	15
		<ul style="list-style-type: none"> <li>Change the position or direction of the outdoor antenna.</li> </ul>	15

# Troubleshooting guide

Trouble	Cause	Remedy	See page
<b>FM/AM</b>			
TUNED and STEREO indicators light but sound is distorted and stereo separation is bad.	<ul style="list-style-type: none"> <li>Station is too strong.</li> <li>Multiple reflection of the radio waves because of tall buildings or mountains.</li> </ul>	<ul style="list-style-type: none"> <li>Change to FM indoor antenna.</li> <li>Use antenna which has better directivity and select a point where the distortion is least.</li> </ul>	15 15
TUNED and STEREO indicators flicker and hiss is heard on FM.	<ul style="list-style-type: none"> <li>Station is too weak.</li> <li>Stereo FM broadcasts cover only about half the distance of an ordinary broadcast.</li> </ul>	<ul style="list-style-type: none"> <li>Install an outdoor FM antenna.</li> <li>Change the position or direction of the outdoor antenna.</li> </ul>	15 15
No station is recalled.	<ul style="list-style-type: none"> <li>The power cord has been unplugged or the POWER switch has been turned off for a long time.</li> </ul>	<ul style="list-style-type: none"> <li>The memory contents are lost. Store all stations again.</li> </ul>	25
<b>Video &amp; audio</b>			
Desired picture does not appear when MULTI CH INPUT button is pressed.	<ul style="list-style-type: none"> <li>Wrong connection.</li> <li>No video input is assigned.</li> </ul>	<ul style="list-style-type: none"> <li>Check the connection again. Insert the plugs and connectors completely.</li> <li>Assign a proper video input.</li> </ul>	9 33
No on-screen display.	<ul style="list-style-type: none"> <li>Improper connection.</li> <li>Improper OSD selector setting.</li> </ul>	<ul style="list-style-type: none"> <li>Check connections.</li> <li>Set the OSD selector properly.</li> </ul>	8 8,9
Picture and sound do not match.	<ul style="list-style-type: none"> <li>Improper connection.</li> <li>Improper video is assigned.</li> </ul>	<ul style="list-style-type: none"> <li>Check connections.</li> <li>Check Video Assign setting.</li> </ul>	8 40
No sound, or sound of the selected source is not heard.	<ul style="list-style-type: none"> <li>The digital input selector is not set properly.</li> </ul>	<ul style="list-style-type: none"> <li>Check Digital Input setting.</li> </ul>	23,29
No picture appears on the TV screen (or monitor).	<ul style="list-style-type: none"> <li>The TV (or monitor) is not set to receive the output signals from the receiver.</li> <li>The video cable is not connected securely.</li> <li>Only S-Video connection is made.</li> </ul>	<ul style="list-style-type: none"> <li>Set the TV (or monitor) to the receiver input.</li> <li>Check connections.</li> <li>Make also video connection.</li> </ul>	- 8 8
<b>Others</b>			
LATE NIGHT function cannot be used.	<ul style="list-style-type: none"> <li>Playback source is not Dolby Digital encoded.</li> </ul>	<ul style="list-style-type: none"> <li>Check that the DOLBY DIGITAL indicator lights up on the display.</li> </ul>	38
LFE LEVEL function cannot be used.	<ul style="list-style-type: none"> <li>Playback source is not Dolby Digital , DTS encoded.</li> </ul>	<ul style="list-style-type: none"> <li>Check that the DOLBY DIGITAL, DTS indicator lights up on the display.</li> </ul>	38
Cinema Re-EQ function cannot be used.	<ul style="list-style-type: none"> <li>The listening mode is set to "Stereo," "5ch stereo" or "Direct."</li> </ul>	<ul style="list-style-type: none"> <li>See the table on page 38.</li> </ul>	38
Parameter cannot be set for Front Effect, Reflect Level, Reverb Level, Room Size, etc.	<ul style="list-style-type: none"> <li>Parameter may not be set depending on the listening mode.</li> </ul>	<ul style="list-style-type: none"> <li>See the table on page 38.</li> </ul>	38
Front panel controls function but remote controller does not.	<ul style="list-style-type: none"> <li>No batteries in remote controller.</li> <li>Batteries have worn out.</li> <li>The remote controller is not pointed at the remote sensor of the receiver.</li> <li>The remote controller is too far from the receiver.</li> </ul>	<ul style="list-style-type: none"> <li>Insert batteries.</li> <li>Replace batteries.</li> <li>Point the remote controller at the remote sensor of the receiver.</li> <li>Operate the remote controller within 16 feet (5m).</li> </ul>	5 5 5 5

Also refer to the respective instruction manuals of the video disc player, video cassette recorder, TV monitor, etc., that compose your entertainment system.

Because the unit contains a microcomputer to provide advanced functions, it may malfunction due to external noise or static electricity. If this happens, press the POWER switch on the unit and then press it again after about five seconds.

# Specifications

## DTR-7

### AMPLIFIER SECTION

Continuous Average Power output (FTC)

**All channels:** **105 watts per channel min. RMS at 8 ohms, 2 channels driven from 20 Hz to 20 kHz with no more than 0.08% total harmonic distortion.**  
**135 watts min. RMS at 6 ohms, 2 channels driven from 1 kHz with no more than 0.1% total harmonic distortion.**

Total Harmonic Distortion: 0.08% at rated power (Front)  
 IM Distortion: 0.08% at rated power (Front)  
 Damping Factor: 60 at 8 ohms (Front)  
 Input Sensitivity and Impedance  
 PHONO: 2.5 mV, 50 kohms  
 LINE (CD, TAPE, DVD, VIDEO 1, 2, 3,4): 200 mV, 50 kohms  
 MULTICHANNEL INPUT (FRONT L/R, SURROUND L/R, CENTER): 200 mV, 50 kohms  
 (SUBWOOFER): 36 mV, 50 kohms  
 COAXIAL 1, 2 (DIGITAL): 0.5 Vp-p, 75 ohms  
 Output Level and Impedance  
 Rec out (TAPE, VIDEO 1): 200 mV, 2.2 kohms  
 Pre out: 1 V, 470 ohms  
 Phono Overload: 110 mV RMS at 1 kHz, 0.5% T.H.D.  
 Frequency Response: 20 Hz to 100 kHz, +1/-3 dB(LINE INPUT)  
 RIAA Deviation: 20 Hz to 20 kHz,  $\pm 0.8$  dB  
 Tone Control  
 Bass:  $\pm 10$  dB at 100 Hz  
 Treble:  $\pm 10$  dB at 10 kHz  
 Signal-to-Noise Ratio  
 Phono: 80 dB (IHF A, 5 mV input)  
 CD/Tape: 100 dB (IHF A)

### VIDEO SECTION

Input sensitivity/Impedance (DVD, VIDEO 1, 2, 3,4)  
 VIDEO (Composite): 1 Vp-p, 75 ohms  
 Output Level/Impedance (VIDEO 1, 2, MONITOR)  
 VIDEO (Composite): 1 Vp-p, 75 ohms

## DTR-6

### AMPLIFIER SECTION

Continuous Average Power output (FTC)

**All channels:** **85 watts per channel min. RMS at 8 ohms, 2 channels driven from 20 Hz to 20 kHz with no more than 0.08% total harmonic distortion.**  
**110 watts min. RMS at 6 ohms, 2 channels driven from 1 kHz with no more than 0.1% total harmonic distortion.**

Total Harmonic Distortion: 0.08% at rated power (Front)  
 IM Distortion: 0.08% at rated power (Front)  
 Damping Factor: 60 at 8 ohms (Front)  
 Input Sensitivity and Impedance  
 PHONO: 2.5 mV, 50 kohms  
 LINE (CD, TAPE, DVD, VIDEO 1, 2, 3,4): 200 mV, 50 kohms  
 MULTICHANNEL INPUT (FRONT L/R, SURROUND L/R, CENTER): 200 mV, 50 kohms  
 (SUBWOOFER): 36 mV, 50 kohms  
 COAXIAL 1, 2 (DIGITAL): 0.5 Vp-p, 75 ohms  
 Output Level and Impedance  
 Rec out (TAPE, VIDEO 1): 200 mV, 2.2 kohms  
 Pre out: 1 V, 470 ohms  
 Phono Overload: 110 mV RMS at 1 kHz, 0.5% T.H.D.  
 Frequency Response: 20 Hz to 100 kHz, +1/-3 dB(LINE INPUT)  
 RIAA Deviation: 20 Hz to 20 kHz,  $\pm 0.8$  dB  
 Tone Control  
 Bass:  $\pm 10$  dB at 100 Hz  
 Treble:  $\pm 10$  dB at 10 kHz  
 Signal-to-Noise Ratio  
 Phono: 80 dB (IHF A, 5 mV input)  
 CD/Tape: 100 dB (IHF A)

### VIDEO SECTION

Input sensitivity/Impedance (DVD, VIDEO 1, 2, 3,4)  
 VIDEO (Composite): 1 Vp-p, 75 ohms  
 Output Level/Impedance (VIDEO 1, 2, MONITOR)  
 VIDEO (Composite): 1 Vp-p, 75 ohms

# Specifications

## DTR-7

### TUNER SECTION

#### FM

Tuning Range:	87.5 - 108.0 MHz (50 kHz steps)
Usable Sensitivity	
Mono:	11.2 dBf, 1.0 $\mu$ V (75 ohms IHF)
Stereo:	17.2 dBf, 2.0 $\mu$ V (75 ohms IHF)
50 dB Quieting Sensitivity	
Mono:	17.2 dBf, 2.0 $\mu$ V (75 ohms)
Stereo:	37.2 dBf, 20 $\mu$ V (75 ohms)
Capture Ratio:	2.0 dB
Image Rejection Ratio	40 dB

IF Rejection Ratio: 90 dB

Signal-to-Noise Ratio

  Mono: 76 dB

  Stereo: 70 dB

Alternate Channel Attenuation: 55 dB

AM Suppression Ratio: 50 dB

Total Harmonic Distortion

  Mono: 0.2%

  Stereo: 0.3%

Frequency Response: 30 Hz - 15 kHz,  $\pm$ 1.0 dB

Stereo Separation: 45 dB at 1 kHz

30 dB at 100 Hz - 10 kHz

#### AM

Tuning Range 530 - 1,710 kHz (10 kHz steps)

Usable Sensitivity: 30  $\mu$ V

Image Rejection Ratio: 40 dB

IF Rejection Ratio: 40 dB

Signal-to-Noise Ratio: 40 dB

Total Harmonic Distortion: 0.7%

#### GENERAL

Power Supply: AC 120 V, 60 Hz

Power Consumption: 6.2A

Dimensions (W  $\times$  H  $\times$  D):  
435  $\times$  175  $\times$  453 mm  
17-1/8"  $\times$  6-7/8"  $\times$  17-13/16"

Weight: 16.3 kg, 35.9 lbs.

#### REMOTE CONTROL

Transmitter: Infrared

Signal range: Approx. 5 meters, 16 ft.

Power supply: Two "AA" batteries (1.5 V  $\times$  2)

Specifications and features are subject to change without notice.

## DTR-6

### TUNER SECTION

#### FM

Tuning Range:	87.5 - 108.0 MHz (50 kHz steps)
Usable Sensitivity	
Mono:	11.2 dBf, 1.0 $\mu$ V (75 ohms IHF)
Stereo:	17.2 dBf, 2.0 $\mu$ V (75 ohms IHF)
50 dB Quieting Sensitivity	
Mono:	17.2 dBf, 2.0 $\mu$ V (75 ohms)
Stereo:	37.2 dBf, 20 $\mu$ V (75 ohms)
Capture Ratio:	2.0 dB
Image Rejection Ratio	40 dB

IF Rejection Ratio: 90 dB

Signal-to-Noise Ratio

  Mono: 76 dB

  Stereo: 70 dB

Alternate Channel Attenuation: 55 dB

AM Suppression Ratio: 50 dB

Total Harmonic Distortion

  Mono: 0.2%

  Stereo: 0.3%

Frequency Response: 30 Hz - 15 kHz,  $\pm$ 1.0 dB

Stereo Separation: 45 dB at 1 kHz

30 dB at 100 Hz — 10 kHz

#### AM

Tuning Range 530 - 1,710 kHz (10 kHz steps)

Usable Sensitivity: 30  $\mu$ V

Image Rejection Ratio: 40 dB

IF Rejection Ratio: 40 dB

Signal-to-Noise Ratio: 40 dB

Total Harmonic Distortion: 0.7%

#### GENERAL

Power Supply: AC 120 V, 60 Hz

Power Consumption: 5.3A

Dimensions (W  $\times$  H  $\times$  D):  
435  $\times$  175  $\times$  453 mm  
17-1/8"  $\times$  6-7/8"  $\times$  17-13/16"

Weight: 14.7 kg, 32.4 lbs.

#### REMOTE CONTROL

Transmitter: Infrared

Signal range: Approx. 5 meters, 16 ft.

Power supply: Two "AA" batteries (1.5 V  $\times$  2)

Specifications and features are subject to change without notice.



# Control positions and names

The illustration shows the front panel of the DTR-7 model. The appearance of the front panel varies depending on the model you purchased.

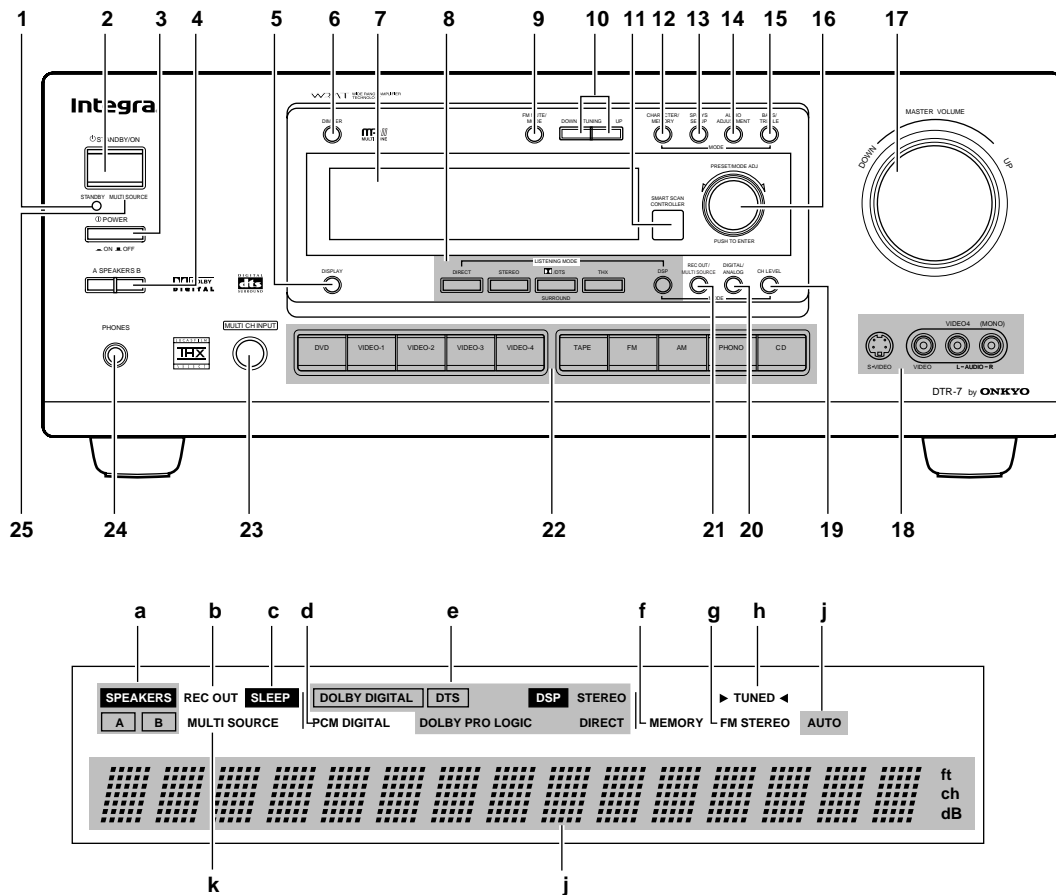

## Front panel

For more information about buttons or knobs, refer to the pages listed in the brackets ( [ ] ) below.

1. STANDBY indicator [5, 13]
2. STANDBY/ON button [13]
3. POWER switch [13]
4. SPEAKERS A/B button [26, 30]
5. DISPLAY button [23, 30, 47]
6. DIMMER button [26]
7. Display (Refer to the "Display" illustration.)
8. LISTENING MODE buttons [35, 36, 38]
9. FM MUTE/MODE button [24]
10. TUNING UP/DOWN button [23]
11. Remote control sensor [5]
12. CHARACTER/MEMORY buttons [25, 41]
13. SP/SYS SETUP button [16, 18, 20~22, 40, 43]
14. AUDIO ADJUSTMENT button [38]
15. BASS/TREBLE button [31]
16. SMART SCAN CONTROLLER [16, 32]
17. MASTER VOLUME control knob [26, 35]
18. VIDEO-4/VIDEO CAM INPUT [8]
19. CH LEVEL button [42]
20. DIGITAL/ANALOG button [23, 28]
21. REC OUT/MULTI SOURCE button [44~47]
22. INPUT SELECTOR buttons [23, 26, 32, 35]
23. MULTI CHANNEL INPUT button [33]

## 24. PHONES [26]

## 25. MULTI SOURCE indicator [47]

## Display

If a protective film on the surface of the screen making it difficult to read the display, remove the film.

- a. Speakers A/B indicators
- b. Rec out indicator
- c. Sleep indicator
- d. PCM digital indicator
- e. Listening mode or Digital input format indicators
- f. Memory indicator
- g. FM Stereo indicator
- h. Tuned indicators
- i. Auto indicator
- j. Multi function display (Frequency and Preset station/Input selector/Sleep time/Volume level/Listening mode)
- k. MULTI SOURCE indicator

# Control positions and names

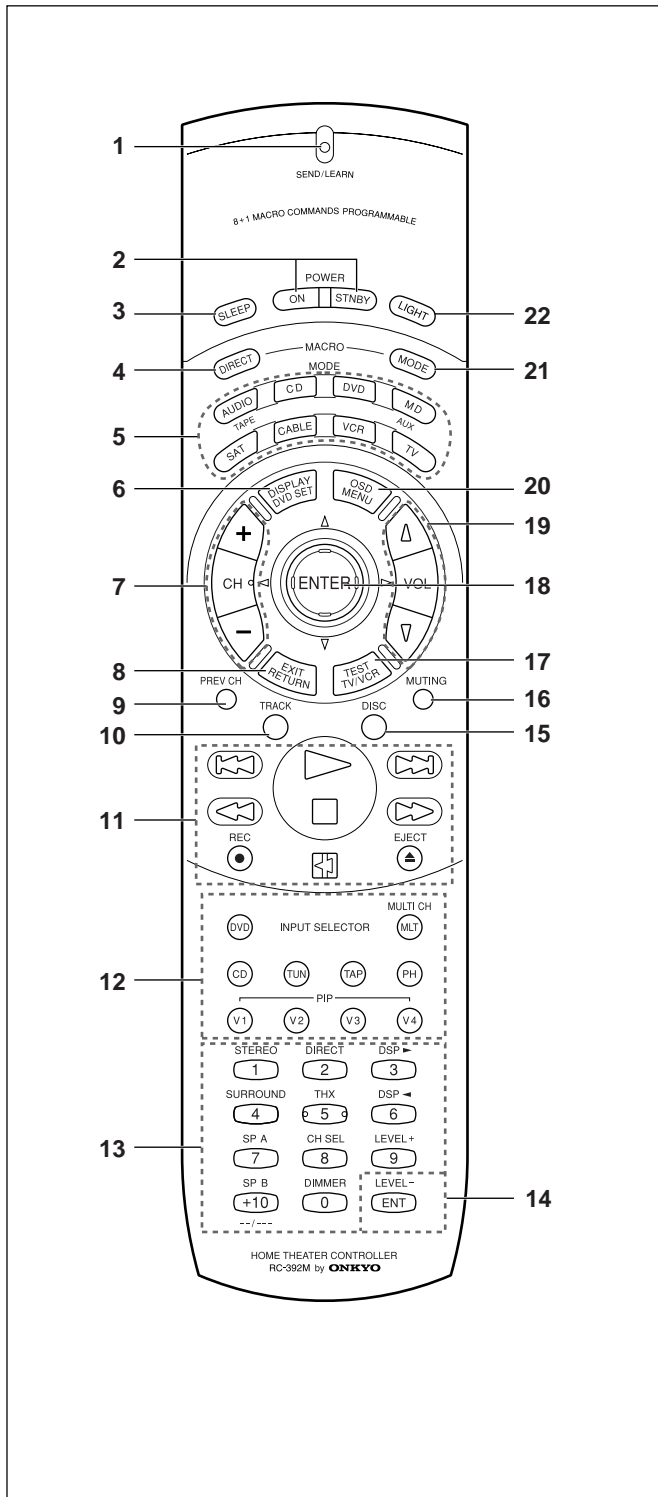

## Remote controller

Using the remote controller, you can control a CD player or cassette tape deck connected to the connector of the DTR-7/6. (See page 7 for more information.)

1. **SEND/LEARN indicator** [49, 52, 53]
2. **POWER ON/STNBY button** [13, 49, 50, 54, 57]  
Power on/Standby on
3. **SLEEP button** [27, 31, 49]  
Sleep function button
4. **MACRO DIRECT button** [55, 56]  
Macro Direct function
5. **MODE buttons** [13, 27, 49~56]
6. **DISPLAY/DVD SET button** [49, 50]
7. **CH +/- buttons** [32, 49]
8. **EXIT/RETURN button** [16, 17, 50]
9. **PREV CH button**  
[This button is not used for this receiver.]
10. **TRACK button** [50]
11. **CD/TAPE/DVD/MD operation buttons** [50, 51]
12. **Input Selector buttons** [27, 32, 35, 49]
13. **Numeric key/STEREO/DSP ◀, ▶/SURROUND/SPA, B/CH SEL/LEVEL+,-/DIMMER buttons** [21, 27, 33, 35, 42, 49~51]  
[The THX button are not used for the DTR-6.]
14. **ENT button** [50~53, 57]
15. **DISC button** [50]
16. **MUTING button** [31, 32, 49, 50]
17. **TEST/TV/VCR button** [49]
18. **ENTER/cursor buttons** [16, 17, 50]  
Volume adjustment
19. **VOL Δ/Δ button** [27, 35, 49, 50]
20. **OSD/MENU button** [16, 17, 50]
21. **MACRO MODE button** [54, 56]
22. **LIGHT button** [49]

**ONKYO U.S.A. CORPORATION**  
200 Williams Drive, Ramsey, N.J. 07446, U.S.A.  
Tel: 201-825-7950 Fax: 201-825-8150 E-mail: [integra@onkyousa.com](mailto:integra@onkyousa.com)

SN 29342732  
Printed in Japan  
D9907-1



## Free Manuals Download Website

<http://myh66.com>

<http://usermanuals.us>

<http://www.somanuals.com>

<http://www.4manuals.cc>

<http://www.manual-lib.com>

<http://www.404manual.com>

<http://www.luxmanual.com>

<http://aubethermostatmanual.com>

Golf course search by state

<http://golfingnear.com>

Email search by domain

<http://emailbydomain.com>

Auto manuals search

<http://auto.somanuals.com>

TV manuals search

<http://tv.somanuals.com>