

AV Receiver

DTR-8.4

Instruction Manual

Integra

WARNING:

TO REDUCE THE RISK OF FIRE OR ELECTRIC SHOCK, DO NOT EXPOSE THIS APPARATUS TO RAIN OR MOISTURE.

CAUTION:

TO REDUCE THE RISK OF ELECTRIC SHOCK, DO NOT REMOVE COVER (OR BACK). NO USER-SERVICEABLE PARTS INSIDE. REFER SERVICING TO QUALIFIED SERVICE PERSONNEL.



WARNING
RISK OF ELECTRIC SHOCK
DO NOT OPEN

AVIS
RISQUE DE CHOC ELECTRIQUE
NE PAS OUVRIR



The lightning flash with arrowhead symbol, within an equilateral triangle, is intended to alert the user to the presence of uninsulated "dangerous voltage" within the product's enclosure that may be of sufficient magnitude to constitute a risk of electric shock to persons.



The exclamation point within an equilateral triangle is intended to alert the user to the presence of important operating and maintenance (servicing) instructions in the literature accompanying the appliance.

Important Safety Instructions

1. Read these instructions.
2. Keep these instructions.
3. Heed all warnings.
4. Follow all instructions.
5. Do not use this apparatus near water.
6. Clean only with dry cloth.
7. Do not block any ventilation openings. Install in accordance with the manufacturer's instructions.
8. Do not install near any heat sources such as radiators, heat registers, stoves, or other apparatus (including amplifiers) that produce heat.
9. Do not defeat the safety purpose of the polarized or grounding-type plug. A polarized plug has two blades with one wider than the other. A grounding type plug has two blades and a third grounding prong. The wide blade or the third prong are provided for your safety. If the provided plug does not fit into your outlet, consult an electrician for replacement of the obsolete outlet.
10. Protect the power cord from being walked on or pinched particularly at plugs, convenience receptacles, and the point where they exit from the apparatus.
11. Only use attachments/accessories specified by the manufacturer.
12. Use only with the cart, stand, tripod, bracket, or table specified by the manufacturer, or sold with the apparatus. When a cart is used, use caution when moving the cart/apparatus combination to avoid injury from tip-over.

PORTABLE CART WARNING



S3125A
13. Unplug this apparatus during lightning storms or when unused for long periods of time.
14. Refer all servicing to qualified service personnel. Servicing is required when the apparatus has been damaged in any way, such as power-supply cord or plug is damaged, liquid has been spilled or objects have fallen into the apparatus, the apparatus has been exposed to rain or moisture, does not operate normally, or has been dropped.
15. Damage Requiring Service

Unplug the apparatus from the wall outlet and refer servicing to qualified service personnel under the following conditions:

 - A. When the power-supply cord or plug is damaged,
 - B. If liquid has been spilled, or objects have fallen into the apparatus,
 - C. If the apparatus has been exposed to rain or water,
 - D. If the apparatus does not operate normally by following the operating instructions. Adjust only those controls that are covered by the operating instructions as an improper adjustment of other controls may result in damage and will often require extensive work by a qualified technician to restore the apparatus to its normal operation,
 - E. If the apparatus has been dropped or damaged in any way, and
 - F. When the apparatus exhibits a distinct change in performance this indicates a need for service.
16. Object and Liquid Entry

Never push objects of any kind into the apparatus through openings as they may touch dangerous voltage points or short-out parts that could result in a fire or electric shock.

The apparatus shall not be exposed to dripping or splashing and no objects filled with liquids, such as vases shall be placed on the apparatus.

Don't put candles or other burning objects on top of this unit.
17. Batteries

Always consider the environmental issues and follow local regulations when disposing of batteries.
18. If you install the apparatus in a built-in installation, such as a bookcase or rack, ensure that there is adequate ventilation.

Leave 20 cm (8") of free space at the top and sides and 10 cm (4") at the rear. The rear edge of the shelf or board above the apparatus shall be set 10 cm (4") away from the rear panel or wall, creating a flue-like gap for warm air to escape.

Precautions

For U.S. Models

Note to CATV system installer:

This reminder is provided to call the CATV system installer's attention to Section 820-40 of the NEC which provides guidelines for proper grounding and, in particular, specifies that the cable ground shall be connected to the grounding system of the building, as close to the point of cable entry as practical.

FCC Information for User

CAUTION:

The user changes or modifications not expressly approved by the party responsible for compliance could void the user's authority to operate the equipment.

NOTE:

This equipment has been tested and found to comply with the limits for a Class B digital device, pursuant to Part 15 of the FCC Rules.

These limits are designed to provide reasonable protection against harmful interference in a residential installation. This equipment generates, uses and can radiate radio frequency energy and, if not installed and used in accordance with the instructions, may cause harmful interference to radio communications. However, there is no guarantee that interference will not occur in a particular installation.

If this equipment does cause harmful interference to radio or television reception, which can be determined by turning the equipment off and on, the user is encouraged to try to correct the interference by one or more of the following measures:

- Reorient or relocate the receiving antenna.
- Increase the separation between the equipment and receiver.
- Connect the equipment into an outlet on a circuit different from that to which the receiver is connected.
- Consult the dealer or an experienced radio/TV technician for help.

For Canadian model

NOTE: THIS CLASS B DIGITAL APPARATUS COMPLIES WITH CANADIAN ICES-003.

RSS-210, Low Power Licence-Exempt Radiocommunications Devices (All Frequency Bands)

For models having a power cord with a polarized plug:

CAUTION: TO PREVENT ELECTRIC SHOCK, MATCH WIDE BLADE OF PLUG TO WIDE SLOT, FULLY INSERT.

Modèle pour les Canadien

REMARQUE: CET APPAREIL NUMÉRIQUE DE LA CLASSE B EST CONFORME À LA NORME NMB-003 DU CANADA.

CNR-210, Dispositifs de radiocommunications de faible puissance, exempts de licence (pour toutes les bandes de fréquences)

Sur les modèles dont la fiche est polarisée:

ATTENTION: POUR ÉVITER LES CHOCS ÉLECTRIQUES, INTRODUIRE LA LAME LA PLUS LARGE DE LA FICHE DANS LA BORNE CORRESPONDANTE DE LA PRISE ET POUSSER JUSQU'AU FOND.

1. **Recording Copyright**—Unless it's for personal use only, recording copyrighted material is illegal without permission of the copyright holder.
2. **AC Fuse**— The AC fuse inside the DTR-8.4 is not user-serviceable. If you cannot turn on the DTR-8.4, contact your Integra/Onkyo dealer.
3. **Care**—Occasionally you should dust the DTR-8.4 all over with a soft cloth. For stubborn stains, use a soft cloth dampened with a weak solution of mild detergent and water. Dry the DTR-8.4 immediately afterwards with a clean cloth. Don't use abrasive cloths, thinners, alcohol, or other chemical solvents, because they may damage the finish or remove the panel lettering.

4. Power

WARNING

BEFORE PLUGGING IN THE UNIT FOR THE FIRST TIME, READ THE FOLLOWING SECTION CAREFULLY.

AC outlet voltages vary from country to country. Make sure that the voltage in your area meets the voltage requirements printed on the DTR-8.4's rear panel (e.g., AC 230 V, 50 Hz or AC 120 V, 60 Hz).

Setting the [STANDBY/ON] switch to STANDBY does not fully shutdown the DTR-8.4. If you do not intend to use the DTR-8.4 for an extended period, remove the power cord from the AC outlet.

Table of Contents

Basic

Introduction

Important Safety Instructions	2
Precautions	3
Features	6
Supplied Accessories.....	7
Before Using the DTR-8.4.....	8
Front & Rear Panels.....	9
Remote Controller.....	14
About Home Theater	21

Connecting the DTR-8.4

Positioning Your Speakers	22
Attaching the Speaker Labels.....	22
Connecting Your Speakers.....	23
Connecting Antennas.....	24
AV Cables & Sockets	26
Connecting Your TV or Projector	27
AV Components	28
Audio Components.....	34
Connecting a Power Amp.....	36
Connecting RI Components.....	36
Connecting the Power Cords of Other Components	37
Connecting the RS232 Port.....	37
Connecting the Power Cord.....	37
Turning On the DTR-8.4.....	38

Basic Setup

About the Onscreen Setup Menus	39
Speaker Settings.....	40
Input Setup	45
Digital Setup.....	45
Video Setup.....	46
Component Video Setup	47
Remote Setup.....	48
Specifying the TV System (Australian model only).....	49
Changing the Input Source Display	50

Basic Operation

Selecting the Source AV Component.....	51
Muting the DTR-8.4 (remote controller only).....	52
Using the Sleep Timer (remote controller only).....	52
Setting the Display Brightness	52
Using Headphones.....	52
Setting the Input Signal Format.....	53
Fixing the Digital Input Format	53
Using the Tuner	54
Listening Modes.....	56
Using the Digital Surround Modes	60
Display Indicators & Source Info	61
Adjusting the Volume of Individual Speakers	62
Using the Re-EQ function	62
Using the Late Night function.....	62

Others

Troubleshooting	99
Specifications.....	103

Table of Contents—Continued

Advanced

Using the Remote Controller with Other Components

Entering a Remote Control Code	88
Remote Control Codes	89
Controlling a Satellite Receiver	91
Controlling a VCR	91
Controlling a TV	92
Controlling a Cable Receiver	92
Learning Commands from Another Remote Controller	93
Using Macros	94
Editing Remote Controller Modes	96
Adding New Remote Controller Modes	96
Reordering the Remote Controller Modes.....	96
Deleting Remote Controller Modes	97
Assigning Remote Controller Modes.....	97
Changing the Remote Controller's Transmission Signal Format (IR/RF)	98
Resetting the Remote Controller	98

Advanced Features

Advanced Setup

Assigning Listening Modes to Input Sources	67
Assigning the A & B 12V Trigger Outputs	68
Audio Adjust Functions	68
Setting Preferences	72
Volume Setup	72
Headphones Level	72
OSD Setup	73
OSD Position	73
Naming Presets & Input Sources	73
Using IntelliVolume	74

Advanced Features

Advanced Operation

Using the Multichannel Input	63
Recording	65

Advanced Features

Net-Tune

About Net-Tune	75
Networking Your DTR-8.4	76
Using Internet Radio	77
Playing Net-Tune Server Tracks	79
Music Server Settings	81
Network Settings	82

Advanced Features

Zone 2

Connecting Zone 2	84
Using the Remote Control in Zone 2	85
Setting the Surr Back/Zone 2 Outputs	86
Controlling Zone 2	87

Introduction 2

Connecting the DTR-8.4 22

Basic Setup 39

Basic Operation 51

Advanced Operation 63

Advanced Setup 67

Net-Tune 75

Zone 2 84

Using the Remote Controller with Other Components 88

Others 99

Features

Amp

- 7-channel amplifier
- 110 watts per channel into 8 ohms, 20 Hz to 20 kHz, less than 0.08% total harmonic distortion (FTC rating)
- WRAT (Wide Range Amplifier Technology)
- Optimum Gain Volume Circuitry
- 192 kHz/24-bit D/A converters (not surround back channels)
- Zone 2 (multiroom/multisource) capability

Audio/Video

- THX Surround EX^{*1}
- THX Select certified
- Dolby Digital, Dolby Digital EX, Dolby Pro Logic II^{*2}
- DTS, DTS-ES Discrete, DTS-ES Matrix, DTS Neo:6, and DTS 96/24^{*3}
- Theater-Dimensional virtual surround mode^{*4}
- Non-Scaling configuration
- Advanced 32-bit dual DSP chips
- 96 kHz/24-bit D/A converters (surround back channels only)
- 2 component video inputs, 1 output
- Composite video to S-Video and S-Video to composite video conversion
- Composite and S-Video to component video upconversion
- 6 S-Video inputs, 3 outputs
- 7 assignable digital inputs (4 optical, 3 coaxial), 2 digital outputs, 1 optical digital input for video 5 input
- Pre outs for front L/R, center, surround L/R, surround back L/R (or Zone 2 L/R), and Subwoofer

FM/AM Tuner

- 40 FM/AM presets
- FM auto tuning

Others

- Easy-to-use onscreen setup menus (OSD)
- Remote controller has scroll wheel and LCD display for quick and easy operation
- VLSC (Vector Linear Shaping Circuitry) for left, center, and right channels
- IntelliVolume
- Character input for naming radio presets and input sources
- Net-Tune for Internet radio and MP3 and WAV playback
- Ethernet port for use with Net-Tune

THX Select

Before any home theater component can be THX Select certified, it must pass a rigorous series of quality and performance tests. Only then can a product feature the THX Select logo, which is your guarantee that the Home Theater products you purchase will give you superb performance for many years to come. THX Select requirements define hundreds of parameters, including power amplifier performance, and pre-amplifier performance and operation for both digital and analog domains. THX Select receivers also feature proprietary THX technologies (e.g., THX Mode) which accurately translate movie soundtracks for home theater playback.

*1. THX is a trademark or registered trademark of THX Ltd.

*2. Manufactured under license from Dolby Laboratories. Dolby, Pro Logic, Surround EX, and the double-D symbol are trademarks of Dolby Laboratories.

*3. DTS, DTS 96/24, DTS-ES, and Neo:6 are trademarks of Digital Theater Systems, Inc.

*4. Theater-Dimensional and Net-Tune are trademarks of Onkyo Corporation.

Re-Equalization and the Re-EQ logo are trademarks of THX Ltd.



Windows Media, and the Windows logo are trademarks, or registered trademarks of Microsoft Corporation in the United States and/or other countries.

Intel and Pentium are registered trademarks of Intel Corporation.

MPEG Layer-3 audio coding technology licensed from Fraunhofer IIS and Thomson Multimedia.

Xiva is a registered trademark of Imerge Limited.

Xantech is a registered trademark of Xantech Corporation.

Niles is a registered trademark of Niles Audio Corporation.

Ethernet is a registered trademark of Xerox Corporation.

* In catalogs and on packaging, the letter added to the end of the product name indicates the color of the DTR-8.4. Specifications and operation are the same regardless of color.

Thank you for purchasing an Integra/Onkyo AV Receiver.
Please read this manual thoroughly before making connections and plugging in the unit.
Following the instructions in this manual will enable you to obtain optimum performance and listening enjoyment from your new AV Receiver.
Please retain this manual for future reference.

Supplied Accessories

Make sure you have the following accessories:

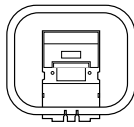

AM loop antenna

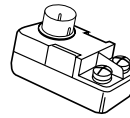

75/300-ohm antenna adapter
(Australian model only)

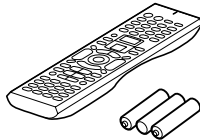

Remote controller (RC-550M) & three batteries (AA/R6)

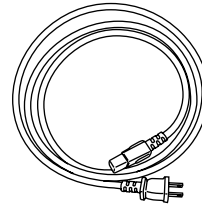

Power cord
(Plug type varies from country to country)



Indoor FM antenna
(Connector type varies from country to country.)

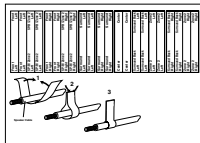

Speaker cable labels

Before Using the DTR-8.4

Installing the Batteries

- 1** To open the battery compartment, press the small hollow and slide off the cover.

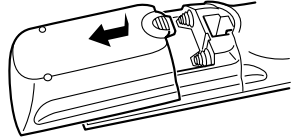

- 2** Insert the three supplied batteries (AA/R6) in accordance with the polarity diagram inside the battery compartment.

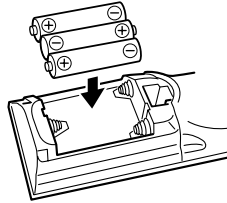

- 3** Put the cover onto the remote controller and slide it shut.

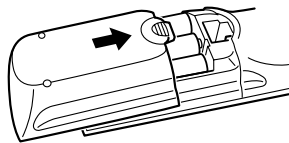

Notes:

- The batteries should last for about six months, although this will vary with usage.
- If the remote controller doesn't work reliably, try replacing the batteries.
- Don't mix new and old batteries or different types of batteries.
- If you intend not to use the remote controller for a long time, remove the batteries to prevent damage from leakage or corrosion.
- Expired batteries should be removed as soon as possible to prevent damage from leakage or corrosion.

Using the Remote Controller

To use the remote controller, point it at the DTR-8.4's remote control sensor, as shown below.

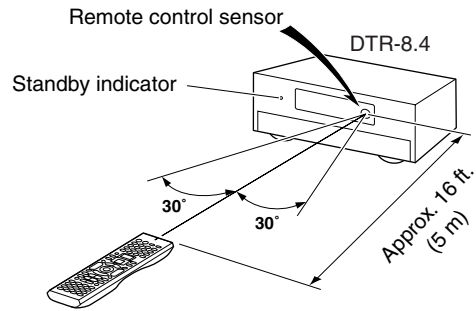

Notes:

- The remote controller may not work reliably if the DTR-8.4 is subjected to bright light, such as direct sunlight or inverter-type fluorescent lights. Keep this in mind when installing.
- If another remote controller of the same type is used in the same room, or the DTR-8.4 is installed close to equipment that uses infrared rays, the remote controller may not work reliably.
- Don't put anything, such as a book, on the remote controller, because the buttons may be pressed inadvertently, thereby draining the batteries.
- The remote controller may not work reliably if the DTR-8.4 is installed in a rack behind colored glass doors. Keep this in mind when installing.
- The remote controller will not work if there's an obstacle between it and the DTR-8.4's remote control sensor.
- You can set the transmission signal format to infrared (IR), or radio frequency (RF) for use with the optional RF Receiver. This is useful when, for example, the DTR-8.4 is installed in a rack or is not in line of sight of the remote controller.

Front & Rear Panels

Front Panel

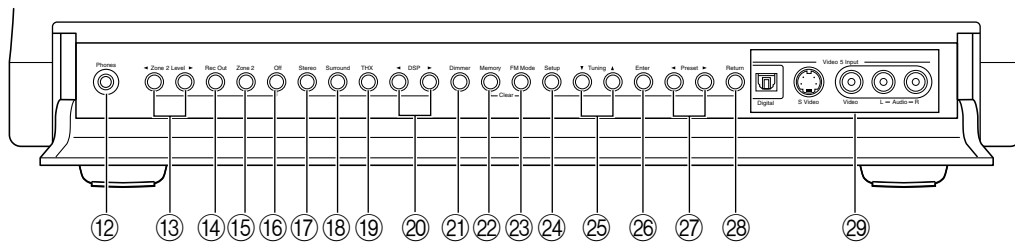
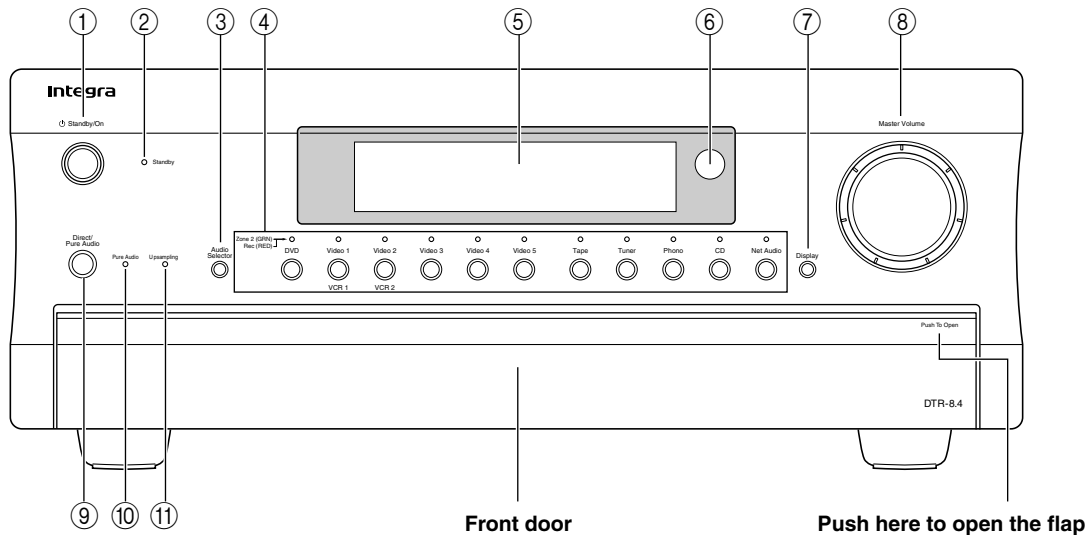

For detailed information, refer to the pages in parenthesis.

- ① **Standby/On button (38)**
This button is used to set the DTR-8.4 to On or Standby.
- ② **Standby indicator (38)**
This indicator lights up when the DTR-8.4 is in Standby mode, and it flashes while a signal is being received from the remote controller.
- ③ **Audio Selector button (53)**
This button is used to select the audio input signal format: analog, digital, or multichannel.
- ④ **Input selector buttons & indicators (51)**
These buttons are used to select the following input sources: DVD, VIDEO 1–5, TAPE, TUNER, PHONO, CD, and NET AUDIO. The indicators show the currently selected input source.

The indicators also show which input source is selected for Zone 2, in which case they light up green, or which input source is selected for recording (REC OUT), in which case they light up red.
- ⑤ **Display**
See “Display” on page 11.

Front & Rear Panels—Continued

- ⑥ **Remote-control sensor (8)**
This sensor receives control signals from the remote controller.
- ⑦ **Display button (61)**
This button is used to display various information about the currently selected input source.
- ⑧ **Master Volume control (51)**
This control is used to set the volume of the DTR-8.4 from 0 to 100.
- ⑨ **Direct/Pure Audio button (59)**
This button is used to select the Direct or Pure Audio listening modes.
- ⑩ **Pure Audio indicator (59)**
This indicator lights up when the Pure Audio listening mode is selected.
- ⑪ **Upsampling indicator (69)**
This indicator lights up when the Upsampling function is on.
- ⑫ **Phones jack (52)**
This 1/4-inch phone jack is for connecting a standard pair of stereo headphones for private listening.
- ⑬ **Zone 2 Level [◀] [▶] buttons (87)**
These buttons are used to set the volume for Zone 2.
- ⑭ **Rec Out button (65)**
This button is used to select the input source that you want to record via the REC OUTs (i.e., TAPE OUT, VIDEO 1 OUT, VIDEO 2 OUT).
- ⑮ **Zone 2 button (87)**
This button is used to select the input source for Zone 2.
- ⑯ **Off button (65, 87)**
This button is used to turn off the REC OUTs (i.e., TAPE OUT, VIDEO 1 OUT, VIDEO 2 OUT) or Zone 2.
- ⑰ **Stereo button (59)**
This button is used to select the Stereo listening mode.
- ⑱ **Surround button (59)**
This button is used to select the Dolby and DTS listening modes.
- ⑲ **THX button (59)**
This button is used to select the THX listening modes.
- ⑳ **DSP [◀] [▶] buttons (59)**
These buttons are used to select the DSP (digital signal processor) listening modes.
- ㉑ **Dimmer button (52)**
This button is used to adjust the display brightness.
- ㉒ **Memory button (54)**
This button is used when storing and deleting radio presets.
- ㉓ **FM Mode button (54)**
This button is used to select the FM radio Auto and Mono modes.
- ㉔ **Setup button**
This button is used to access the onscreen setup menus (OSD) that appear on the TV.
- ㉕ **Tuning [▲] [▼] buttons (54)**
These buttons are used to tune into radio stations and to select items on the onscreen setup menus (OSD).
- ㉖ **Enter button**
This button is used when navigating the onscreen setup menus (OSD), entering names, and confirming settings.
- ㉗ **Preset [◀] [▶] buttons (54)**
These buttons are used to select radio presets and to select items on the onscreen setup menus (OSD).
- ㉘ **Return button**
This button is used to return to the previously displayed onscreen setup menu (OSD).
- ㉙ **Video 5 Inputs (33)**
These optical digital audio, S-Video, composite video, and analog audio inputs can be used to connect a camcorder, games console, and so on.

Front & Rear Panels—Continued

Display

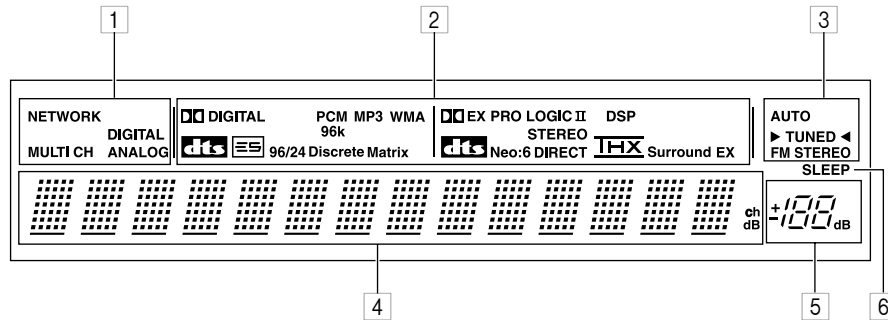

For detailed information, refer to the pages in parenthesis.

1 Audio input format indicators (53)

These indicators show the audio input format for the currently selected input source.

2 Listening mode & digital audio format indicators (61)

These indicators show the currently selected listening mode and digital audio format.

3 Tuning indicators (54)

AUTO indicator:

This indicator lights up when the tuner is tuned to an FM station and Stereo mode is selected. It goes off when Mono mode is selected.

TUNED indicator:

This indicator lights up when the tuner is tuned into an AM or FM station.

FM STEREO indicator:

This indicator lights up when the tuner is tuned to a stereo FM station. It goes off when Mono mode is selected.

4 Multipurpose display area

Normally, the name of the currently selected input source is displayed here. When you select the AM or FM input source, the radio frequency and preset number are displayed. If you press the [Display] button, the currently selected listening mode and digital audio format are displayed.

5 Volume level (51)

The volume level is displayed here.

6 SLEEP indicator (52)

This indicator lights up when the Sleep function has been set.

Front & Rear Panels—Continued

Rear Panel

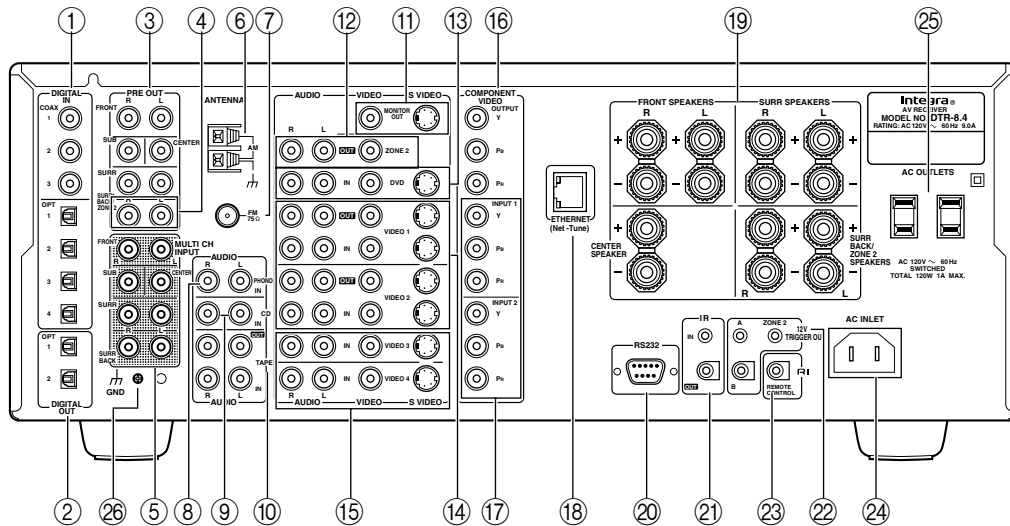

For detailed information, refer to the pages in parenthesis.

- ① **DIGITAL IN COAX 1–3, OPT 1–4 (28, 30, 32, 34, 35)**
These coaxial and optical digital audio inputs can be used to connect CD, DVD, or LD (laser disc) players and other components with digital audio outputs.
- ② **DIGITAL OUT OPT 1 & 2 (35)**
These optical digital audio outputs can be used to connect a CD recorder or other digital recorder with digital inputs.
- ③ **PRE OUT—FRONT L/R, SUB, CENTER, SURR L/R (36)**
If you use the DTR-8.4 as a preamp, these analog audio outputs can be connected to the inputs on a separate power amp. The SUB output is used to connect a powered subwoofer.
- ④ **PRE OUT—SURR BACK/ZONE 2 (36, 84)**
These analog audio outputs can be used to feed the L/R surround back inputs on a separate power amp when the DTR-8.4 is used as a preamp, or to feed a power amp in Zone 2.
- ⑤ **MULTI CH INPUT—FRONT L/R, SUB, CENTER, SURR L/R, SURR BACK L/R (29)**
These analog audio inputs can be used to connect AV components with multiple analog audio outputs, including DVD players with individual 5.1/7.1 surround analog audio outputs.
- ⑥ **AM ANTENNA (24)**
These push terminals are for connecting an AM antenna.
- ⑦ **FM ANTENNA (24)**
This connector is for connecting an FM antenna.
- ⑧ **PHONO IN (35)**
These analog inputs can be used to connect a turntable with a moving-magnet cartridge.
- ⑨ **CD IN (34)**
These analog inputs can be used to connect a CD player with analog outputs.

Front & Rear Panels—Continued

- ⑩ **TAPE IN/OUT (34)**
These analog inputs and outputs can be used to connect a cassette recorder, Mini Disc recorder, or other recorder with analog inputs and outputs.
- ⑪ **MONITOR OUT (27)**
This S-Video or composite video output can be connected to the video input on your TV or projector.
- ⑫ **ZONE 2 OUT (84)**
These composite video and analog audio outputs can be used to feed a TV and an integrated amp in Zone 2.
- ⑬ **DVD IN (28)**
These S-Video, composite video, and analog audio inputs can be used to connect a DVD player.
- ⑭ **VIDEO 1 & 2 IN/OUT (29, 31)**
These S-Video, composite video, and analog audio inputs and outputs can be used to connect one or two video recorders (e.g., VCRs).
- ⑮ **VIDEO 3 & 4 IN (31)**
These S-Video, composite video, and analog audio inputs can be used to connect one or two video sources (e.g., cable TV, satellite TV, or a set-top box).
- ⑯ **COMPONENT VIDEO OUTPUT (27)**
This component video output can be used to connect a TV or projector with a component video input.
- ⑰ **COMPONENT VIDEO INPUT 1 & 2 (28, 30, 32)**
These component video inputs can be used to connect one or two AV components with component video outputs, such as a DVD player.
- ⑱ **ETHERNET (Net-Tune) (76)**
This port is for connecting the DTR-8.4 to your Ethernet network (i.e., router or switch) for use with Net-Tune (i.e., Internet radio and MP3 and WAV playback).
- ⑲ **SPEAKERS (23)**
These terminal posts are for connecting your speakers. The SURR BACK/ZONE 2 terminals can be used with surround back speakers in the main room or speakers in another room (Zone 2).
- ⑳ **RS232 (37)**
This port is for connecting the DTR-8.4 to home automation and external controllers.
- ㉑ **IR IN/OUT (85)**
If you want to use the remote controller to control the DTR-8.4 from Zone 2, or if the DTR-8.4 is installed in a cabinet and the line of sight between the DTR-8.4 and the remote controller is obstructed, a commercially available IR receiver can be connected to the IR IN. A commercially available IR emitter can be connected to the IR OUT to pass the IR signals along to another AV component.
- ㉒ **12V TRIGGER OUT ZONE 2/A/B (68, 85)**
These outputs can be connected to the 12-volt trigger inputs on other components. They output 12 volts (100 milliamperes max). The ZONE 2 TRIGGER OUT outputs 12 volts while the DTR-8.4 is in Zone 2 mode. The A and B outputs can be assigned to input sources, in which case, the assigned trigger output outputs 12 volts while the input source is selected.
- ㉓ **RI REMOTE CONTROL (36)**
This **RI** (Remote Interactive) socket can be connected to the **RI** socket on another Integra/Onkyo AV component. The DTR-8.4's remote controller can then be used to control that component. To use **RI**, you must make an analog RCA/phono audio connection between the DTR-8.4 and the other AV component, even if they are connected digitally.
- ㉔ **AC INLET (37)**
The supplied power cord should be connected here.
- ㉕ **AC OUTLETS (37)**
These switched AC outlets can be used to supply power to other AV components. The connector type depends on the country in which you purchased your DTR-8.4.
- ㉖ **Grounding screw (35)**
This screw is for connecting a turntable's ground wire.

Remote Controller

The DTR-8.4's remote controller is a multipurpose device that can be used to control not just the DTR-8.4 but your other AV components as well. This section explains how its various operating modes can be used to control the DTR-8.4 and various **RI**-compatible Integra/Onkyo components. See page 88 for information on using the remote controller to control Integra/Onkyo components without **RI** and TVs, VCRs, and AV components made by other manufacturers. For detailed information, refer to the pages in parenthesis.

Amp Mode

Amp mode is used to control the DTR-8.4. **To select Amp mode, press the scroll wheel. "AMP" appears on the display.**

Note:

While neither the [Input] button nor [Mode] button is illuminated, rolling the scroll wheel changes the input source and remote controller mode simultaneously.

Boxed numbers are for Net-Tune mode (page 15).

- ① **On button (38)**
This button is used to turn on the DTR-8.4.
- ② **Standby button (38)**
This button is used to set the DTR-8.4 to Standby.
- ③ **Number/letter buttons (54, 55, 73)**
These buttons are used to enter numbers and letters.
- ④ **Custom button (88)**
This button is used to access various settings that you can use to customize the operation of the remote controller.
- ⑤ **Macro button (96)**
This button is used with the Macro function.
- ⑥ **Mode button**
This button is used with the scroll wheel to select the remote controller modes.
- ⑦ **Dimmer button (52)**
This button is used to adjust the display brightness.
- ⑧ **Up/Down/Left/Right [▲]/[▼]/[◀]/[▶] & Enter buttons**
These buttons are used to select items on the onscreen setup menus (OSD). The Enter button is also used to enter names and to confirm settings.
- ⑨ **CH/Disc button (55)**
This button is used to select radio presets.
- ⑩ **Return/Exit button**
This button is used to return to the previously displayed onscreen setup menu (OSD).
- ⑪ **Display button (61)**
This button is used to display various information about the currently selected input source.
- ⑫ **THX button (59)**
This button is used to select the THX listening modes.

- ⑬ **Surround button (59)**
This button is used to select the Dolby and DTS listening modes.
- ⑭ **Direct button (59)**
This button is used to select the Direct listening mode.
- ⑮ **Pure A button (59)**
This button is used to select the Pure Audio listening mode.

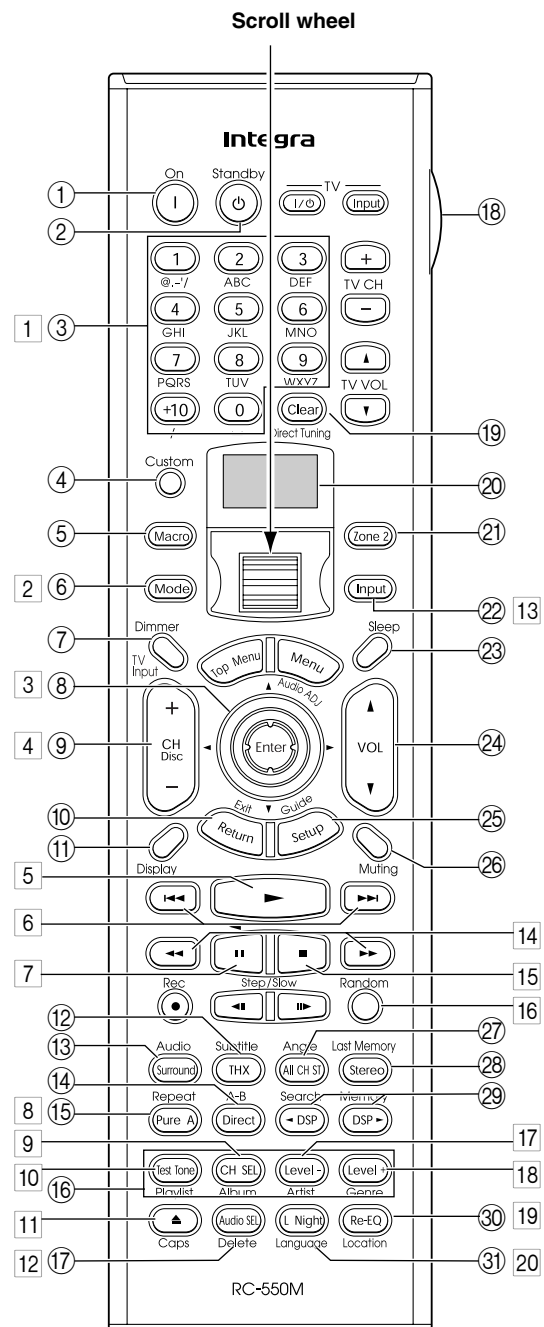

Remote Controller—Continued

⑩ Test Tone, CH SEL, Level– & Level+ buttons (44)

These buttons are used to adjust the level of each speaker individually. These functions can be set only with the remote controller. The [Level–] and [Level+] buttons are also used to adjust the volume in Zone 2.

⑪ Audio SEL button (53)

This button is used to select the audio input signal format: analog, digital, or multichannel.

⑫ Light button

This button is used to turn on or off the remote controller's illuminated buttons.

⑬ Direct Tuning button (54)

This button is used with the number buttons to select a radio station by entering its frequency. Press this button first, and then use the number buttons to enter the frequency.

⑭ Display

The top line of this LCD display shows the name of the currently selected input source. The bottom line shows the currently selected remote controller mode.

⑮ Zone 2 button (87)

This button is used when you want to set the volume and input source for Zone 2.

⑯ Input button (51)

This button is used to select the input source. Press this button first, and then roll the scroll wheel until the name of the input source appears on the display.

⑰ Sleep button (52)

This button is used to set the Sleep function. This function can be set only with the remote controller.

⑱ VOL button (51)

This button is used to set the volume of the DTR-8.4.

⑲ Setup/guide button (39)

This button is used to access the onscreen setup menus (OSD) that appear on the TV.

⑳ Muting button (52)

This button is used to mute the DTR-8.4. This function can be set only with the remote controller.

㉑ All CH ST button (59)

This button is used to select the All Ch Stereo listening mode.

㉒ Stereo button (59)

This button is used to select the Stereo listening mode.

㉓ [◀DSP] & [DSP▶] buttons (59)

These buttons are used to select the DSP (digital signal processor) listening modes.

㉔ Re-EQ button (62)

This button is used to turn on and off the Re-EQ function.

㉕ L Night button (62)

This button is used to set the Late Night function.

Net-Tune Mode

Net-Tune mode is used with the Net-Tune functions. **To select Net-Tune mode, press the [Mode] button, and then roll the scroll wheel until “NET-T” appears on the display.**

Note:

While neither the [Input] button nor [Mode] button is illuminated, the scroll wheel changes the input source and remote controller mode simultaneously. (e.g., set the input source to “MSRV/IRD” and the mode to “NET-T.”)

1 Number/letter buttons (80)

These buttons are used to enter numbers and letters when searching for music in your network audio server music library.

2 Mode button

This button is used with the scroll wheel to select the remote controller modes. Press this button first, and then roll the scroll wheel until “NET-T” appears on the display.

3 Up/Down/Left/Right [▲]/[▼]/[◀]/[▶] & Enter buttons

These buttons are used to navigate Internet radio and network audio server menus. The Enter button is used to confirm items and to start playback of Net-Tune server tracks.

4 CH/Disc button (78)

This button is used to select Internet radio presets.

5 Play [▶] button (80)

This button is used to start playback of network audio server tracks.

6 Previous/Next [◀◀]/[▶▶] buttons (79)

The Previous [◀◀] button is used to select the previous track. During playback it selects the beginning of the current track. The Next [▶▶] button is used to select the next track.

7 Pause [||] button (79)

This button is used to pause playback.

8 Repeat button (80)

This button is used for repeat playback.

9 Album button (79)

This button is used to search your network audio server music library by album.

10 Playlist button (79)

This button is used to search your network audio server library by playlist.

(continued...)

Remote Controller—Continued

11 Caps button (80)

This button is used to select lowercase letters, uppercase letters, and numbers when searching for network audio server music by album, artist, or playlist.

12 Delete button (80)

This button is used to delete characters entered with the number/letter buttons.

13 Input button (77, 79)

This button is used to select the input source. Press this button first, and then roll the scroll wheel until “MSRV” (network audio server) or “IRD” (Internet Radio) appears on the display.

14 FR/FF [◀◀]/[▶▶] buttons (79)

The FR [◀◀] button is used to start fast reverse. The FF [▶▶] button is used to start fast forward.

15 Stop [■] button (79)

This button is used to stop playback.

16 Random button (80)

This button is used for random playback.

17 Artist button (79)

This button is used to search your network audio server music library by artist.

18 Genre button (77, 79)

This button is used to search your network audio server music library by genre, and to search for Internet radio stations by genre.

19 Location button (77)

This button is used to search for Internet radio stations by country.

20 Language button (77)

This button is used to search for Internet radio stations by language.

Connecting your **RI**-compatible Integra/Onkyo DVD player, CD player, MiniDisc recorder, or cassette recorder to the DTR-8.4's **RI** socket allows you to control it with the DTR-8.4's remote controller. You only need to point the remote controller at the DTR-8.4. See page 36 for connection information.

To use the **RI** function, you must make an **RI** connection and an analog RCA/phono audio connection between the AV component and your DTR-8.4, even if they are connected digitally.

DVD Mode

DVD mode is used to control an Integra/Onkyo DVD player connected to the DTR-8.4 via **RI**. **To select DVD mode, press the [Mode] button, and then roll the scroll wheel until “DVD” appears on the display.**

Note:

While neither the [Input] button nor [Mode] button is illuminated, the scroll wheel changes the input source

and remote controller mode simultaneously (e.g., set the input source and mode to “DVD.”)

① On button

This button is used to turn on the DVD player.

② Standby button

This button is used to set the DVD player to Standby.

③ Number/letter buttons

These buttons are used to enter title, chapter, and track numbers and to enter times for locating specific points in time.

④ Mode button

This button is used with the scroll wheel to select the remote controller modes. Press this button first, and then roll the scroll wheel until “DVD” appears on the display.

⑤ Top Menu button

This button is used to select a DVD's top menu.

⑥ Up/Down/Left/Right [▲]/[▼]/[◀]/[▶] & Enter buttons

These buttons are used to navigate DVD menus and the DVD player's onscreen setup menus. The Enter button is used to start playback of the selected menu title, chapter, or track and to confirm settings.

⑦ CH/Disc button

This button is used to select discs on a DVD changer.

⑧ Return/Exit button

This button is used to exit the DVD player's onscreen setup menu and to restart menu playback.

⑨ Display button

This button is used to display information about the current disc, title, chapter, or track, including the elapsed time, remaining time, total time, and so on.

⑩ Previous/Next [◀◀]/[▶▶] buttons

The Previous [◀◀] button is used to select the previous chapter or track. During playback it selects the beginning of the current chapter or track. The Next [▶▶] button is used to select the next chapter or track.

⑪ FR/FF [◀◀]/[▶▶] buttons

The FR [◀◀] button is used to start fast reverse. The FF [▶▶] button is used to start fast forward.

⑫ Pause [||] button

This button is used to pause DVD playback.

⑬ Step/Slow [◀||]/[||▶] buttons

These buttons are used for frame-by-frame playback and slow-motion playback.

⑭ Subtitle button

This button is used to select subtitles.

Remote Controller—Continued

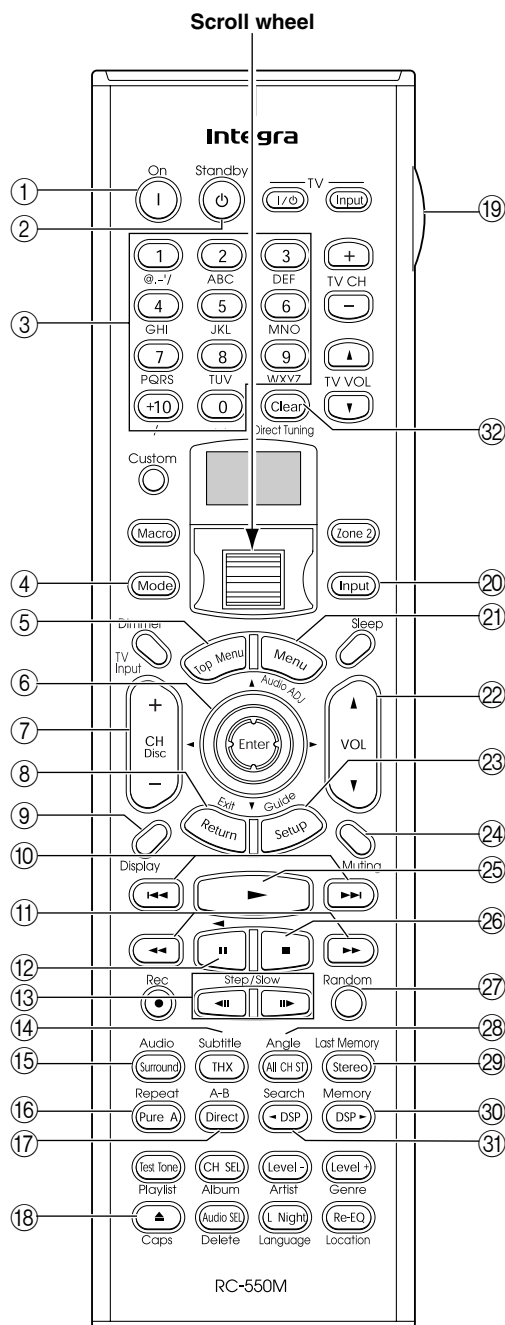

15 Audio button

This button is used to select foreign language soundtracks and audio formats (e.g., Dolby Digital or DTS).

16 Repeat button

This button is used to set the repeat playback functions.

17 A-B button

This button is used to set the A–B repeat playback function.

18 Open/Close [▲] button

This button is used to open and close the disc tray.

19 Light button

This button is used to turn on or off the remote controller's illuminated buttons.

20 Input button

This button is used to select the input source. Press this button first, and then roll the scroll wheel until "DVD" appears on the display.

21 Menu button

This button is used to select a DVD's menu.

22 VOL button

This button is used to set the volume of the DTR-8.4.

23 Setup/Guide button

This button is used to access the DVD player's onscreen setup menus.

24 Muting button

This button is used to mute the DTR-8.4. This function can be set only with the remote controller.

25 Play [▶] button

This button is used to start DVD playback.

26 Stop [■] button

This button is used to stop DVD playback.

27 Random button

This button is used with the random playback function.

28 Angle button

This button is used to select different camera angles.

29 Last Memory button

This button is used with the last memory function, which allows you to resume DVD playback from where you left off.

30 Memory button

This button is used with the memory playback function, which allows you to create a custom playlist of titles, chapters, or tracks.

31 Search button

This button is used to search for titles, chapters, tracks, and specific points in time.

32 Clear button

This button is used to cancel functions and to clear entered numbers.

Remote Controller—Continued

CD Mode

CD mode is used to control an Integra/Onkyo CD player connected to the DTR-8.4 via **RI**. To select CD mode, press the [Mode] button, and then roll the scroll wheel until “CD” appears on the display.

Note:

While neither the [Input] button nor [Mode] button is illuminated, the scroll wheel changes the input source and remote controller mode simultaneously (e.g., set the input source and mode to “CD.”)

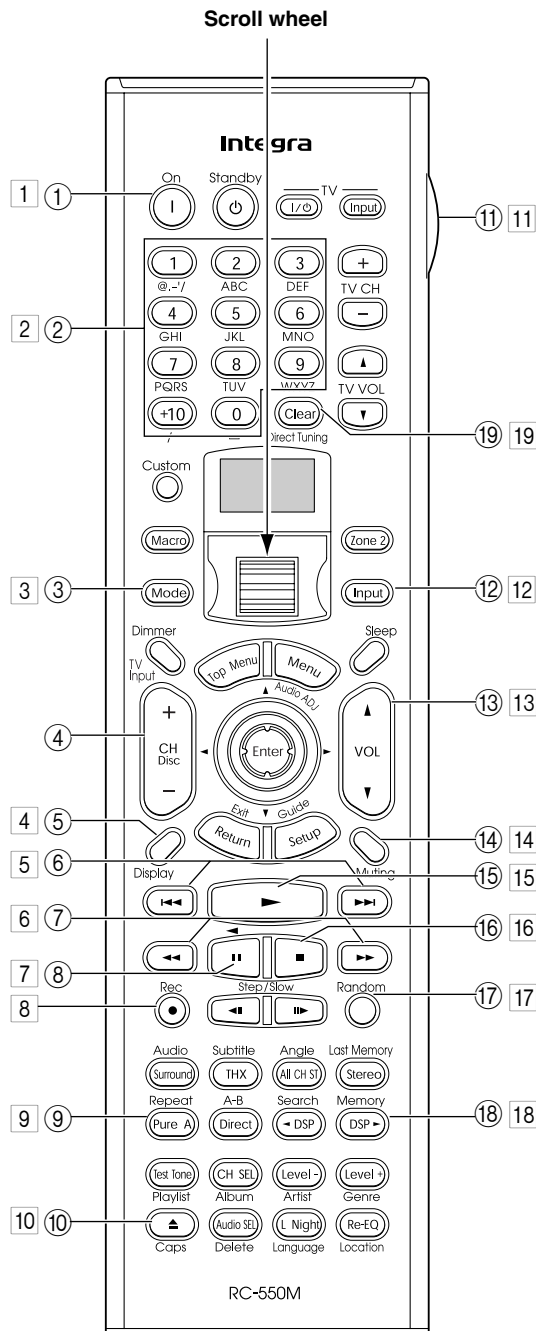

Boxed numbers are for MiniDisc mode (page 19).

- ① **On button**
This button is used to set the CD player to On or Standby.
- ② **Number/letter buttons**
These buttons are used to enter track numbers and to enter times for locating specific points in time.
- ③ **Mode button**
This button is used with the scroll wheel to select the remote controller modes. Press this button first, and then roll the scroll wheel until “CD” appears on the display.
- ④ **CH/Disc button**
This button is used to select discs on a CD changer.
- ⑤ **Display button**
This button is used to display information about the current disc or track, including the elapsed time, remaining time, total time, and so on.
- ⑥ **Previous/Next [◀◀]/[▶▶] buttons**
The Previous [◀◀] button is used to select the previous track. During playback it selects the beginning of the current track. The Next [▶▶] button is used to select the next track.
- ⑦ **FR/FF [◀◀]/[▶▶] buttons**
The FR [◀◀] button is used to start fast reverse. The FF [▶▶] button is used to start fast forward.
- ⑧ **Pause [||] button**
This button is used to pause CD playback.
- ⑨ **Repeat button**
This button is used to set the repeat playback functions.
- ⑩ **Open/Close [▲] button**
This button is used to open and close the disc tray.
- ⑪ **Light button**
This button is used to turn on or off the remote controller's illuminated buttons.
- ⑫ **Input button**
This button is used to select the input source. Press this button first, and then roll the scroll wheel until “CD” appears on the display.
- ⑬ **VOL button**
This button is used to set the volume of the DTR-8.4.
- ⑭ **Muting button**
This button is used to mute the DTR-8.4. This function can be set only with the remote controller.
- ⑮ **Play [▶] button**
This button is used to start CD playback.
- ⑯ **Stop [■] button**
This button is used to stop CD playback.

Remote Controller—Continued

⑰ Random button

This button is used with the random playback function.

⑱ Memory button

This button is used with the memory playback function, which allows you to create a custom playlist of tracks.

⑲ Clear button

This button is used to cancel functions and to clear entered numbers.

MiniDisc Mode

MiniDisc mode is used to control an Integra/Onkyo MiniDisc recorder connected to the DTR-8.4 via **RI**. To select MiniDisc mode, press the [Mode] button, and then roll the scroll wheel until “MD” appears on the display.

Note:

While neither the [Input] button nor [Mode] button is illuminated, the scroll wheel changes the input source and remote controller mode simultaneously (e.g., set the input source and mode to “MD.”)

1 On button

This button is used to set the MiniDisc recorder to On or Standby.

2 Number/letter buttons

These buttons are used to enter track numbers and to enter times for locating specific points in time.

3 Mode button

This button is used with the scroll wheel to select the remote controller modes. Press this button first, and then roll the scroll wheel until “MD” appears on the display.

4 Display button

This button is used to display information about the current disc or track, including the elapsed time, remaining time, total time, and so on.

5 Previous/Next [◀◀]/[▶▶] buttons

The Previous [◀◀] button is used to select the previous track. During playback it selects the beginning of the current track. The Next [▶▶] button is used to select the next track.

6 FR/FF [◀◀]/[▶▶] buttons

The FR [◀◀] button is used to start fast reverse. The FF [▶▶] button is used to start fast forward.

7 Pause [||] button

This button is used to pause MiniDisc playback.

8 Rec [●] button

This button is used to start MiniDisc recording.

9 Repeat button

This button is used to set the repeat playback functions.

10 Eject [▲] button

This button is used to set eject the MiniDisc.

11 Light button

This button is used to turn on or off the remote controller's illuminated buttons.

12 Input button

This button is used to select the input source. Press this button first, and then roll the scroll wheel until “MD” appears on the display.

13 VOL button

This button is used to set the volume of the DTR-8.4.

14 Muting button

This button is used to mute the DTR-8.4. This function can be set only with the remote controller.

15 Play [▶] button

This button is used to start MiniDisc playback.

16 Stop [■] button

This button is used to stop MiniDisc playback.

17 Random button

This button is used with the random playback function.

18 Memory button

This button is used with the memory playback function, which allows you to create a custom playlist of tracks.

19 Clear button

This button is used to cancel functions and to clear entered numbers.

Remote Controller—Continued

Tape Mode

Tape mode is used to control an Integra/Onkyo cassette recorder connected to the DTR-8.4 via **RI**. To select Tape mode, press the scroll wheel. “AMP” appears on the display.

Note:

While neither the [Input] button nor [Mode] button is illuminated, the scroll wheel changes the input source and remote controller mode simultaneously (e.g., set the input source and mode to “TAPE.”)

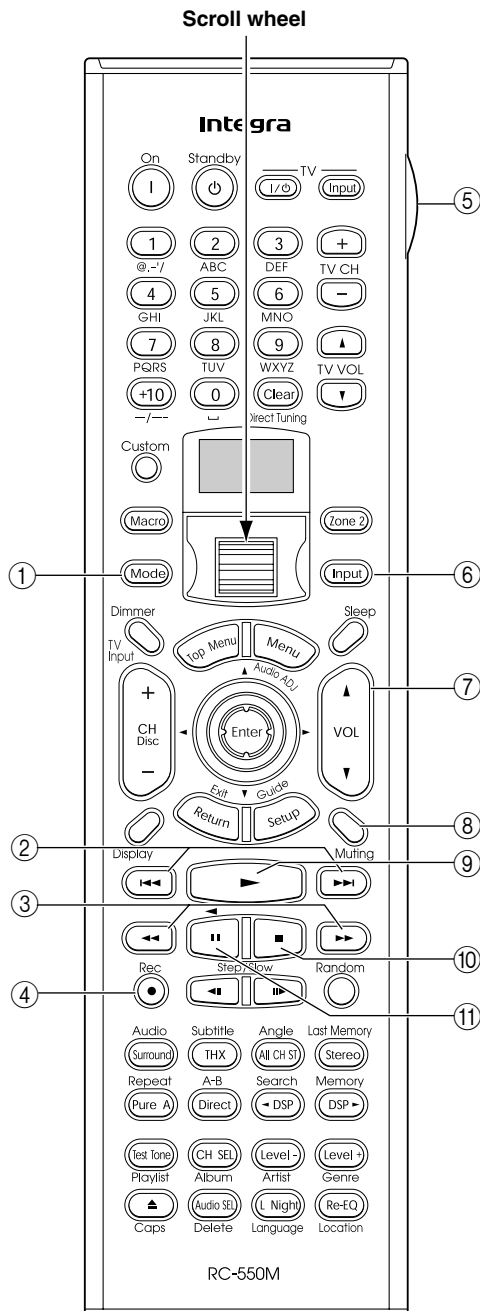

① Mode button

This button is used with the scroll wheel to select the remote controller modes. Press the scroll wheel until “AMP” appears on the display.

② Previous/Next [◀◀]/[▶▶] buttons

The Previous [◀◀] button is used to select the previous track. During playback it selects the beginning of the current track. The Next [▶▶] button is used to select the next track.

The Previous/Next [◀◀]/[▶▶] buttons make not work properly with some cassette tapes depending on how they were recorded.

③ Rewind/FF [◀◀]/[▶▶] buttons

The Rewind [◀◀] button is used to start rewind. The FF [▶▶] button is used to start fast forward.

④ Rec [●] button

This button is used to start tape recording.

⑤ Light button

This button is used to turn on or off the remote controller's illuminated buttons.

⑥ Input button

This button is used to select the input source. Press this button first, and then roll the scroll wheel until “TAPE” appears on the display.

⑦ VOL button

This button is used to set the volume of the DTR-8.4.

⑧ Muting button

This button is used to mute the DTR-8.4. This function can be set only with the remote controller.

⑨ Play [▶] button

This button is used to start tape playback.

⑩ Stop [■] button

This button is used to stop tape playback.

⑪ Reverse Play [◀] button

This button is used to start reverse playback.

About Home Theater

Enjoying Home Theater

With the DTR-8.4's superb functionality you can enjoy surround sound with a real sense of movement in your own home—just like being in a movie theater or concert hall.

For best results with DVDs that feature THX Surround EX, use a THX-certified THX speaker system.

With DVDs you can enjoy DTS, Dolby Digital, and THX soundtracks. With TV and satellite broadcasts you can enjoy Integra's own DSP surround listening modes.

Front left and right speakers

These output the overall sound. Their role in a home theater is to provide a solid anchor for the sound image. They should be positioned facing the listener at about ear level, and equidistant from the TV. Angle them inward so as to create a triangle, with the listener at the apex.

Center speaker

This speaker enhances the front left and right speakers, making sound movements distinct and providing a full sound image. In movies it's used mainly for dialog. Position it close to your TV (preferably on top) facing forward at about ear level, or at the same height as the front left and right speakers.

Subwoofer

The subwoofer handles the bass sounds of the LFE (Low-Frequency Effects) channel. Position it in a corner or one-third of the way along the front wall.

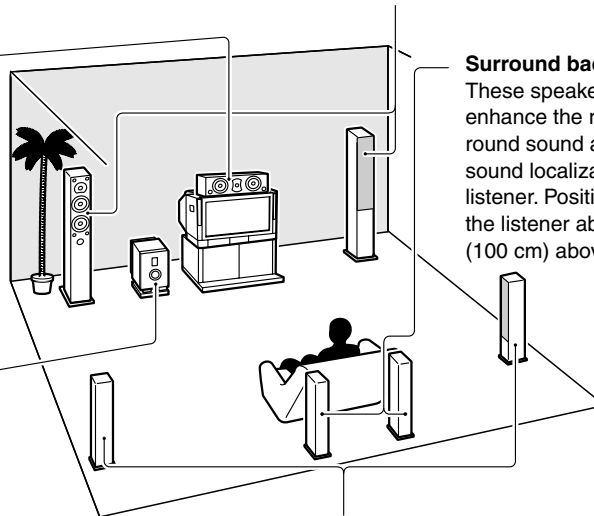

Surround back speakers

These speakers further enhance the realism of surround sound and improve sound localization behind the listener. Position them behind the listener about 3 feet (100 cm) above ear level.

Surround left and right speakers

These speakers are used for precise sound positioning and to add realistic ambience. Position them at the sides of the listener, or slightly behind, about 3 feet (100 cm) above ear level. Ideally they should be equidistant from the listener.

Speaker Configuration

For the best surround-sound experience, you should connect seven speakers and a powered subwoofer.

The following table indicates the channels you should use depending on the number of speakers that you have.

Number of speakers:	2	3	4	5	6	7
Front left	✓	✓	✓	✓	✓	✓
Front right	✓	✓	✓	✓	✓	✓
Center		✓		✓		✓
Surround left			✓	✓	✓	✓
Surround right			✓	✓	✓	✓
Surround back left					✓	✓
Surround back right					✓	✓

No matter how many speakers you use, a powered subwoofer is recommended for a really powerful and solid bass sound.

To get the best from your surround-sound system, you need to specify the distance between the listener and each individual speaker so that the sound from each speaker arrives at the listener's ears at the same time (see page 43). In addition, you need to calibrate the level of each speaker individually to achieve the correct balance (see page 44.)

Connecting the DTR-8.4

Positioning Your Speakers

This section explains how to position your speakers. The picture on page 21 shows the general speaker positions.

Front Left & Right Speakers

The front left and right speakers should be positioned facing the listener at about ear level, and equidistant from the TV. Angle them inward so as to create a triangle, with the listener at the apex.

Center Speaker

The center speaker should be positioned close to your TV (preferably on top) facing forward at about ear level, or at the same height as the front left and right speakers.

Surround Left & Right Speakers

The surround left and right speakers should be positioned at the sides of the listener, or slightly behind, about 3 feet (100 cm) above ear level. Ideally they should be equidistant from the listener.

Surround Back Left & Right Speakers

The surround back left and right speakers are necessary to enjoy Dolby Digital EX, THX Surround EX, DTS-ES Matrix, and DTS-ES Discrete.

Position them behind the listener about 3 feet (100 cm) above ear level.

They should be equidistant from the listener, creating a triangle. Make sure that the angle at the apex of the triangle is about 60 degrees. This is recommended by THX.

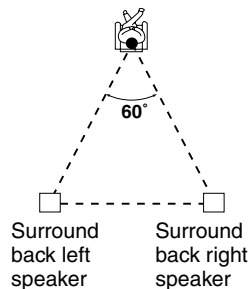

Subwoofer

The volume and quality of the bass output from your subwoofer will depend on its position, the shape of your listening room, and your listening position. In general, the best bass sound can be obtained by putting the subwoofer in a front corner or one-third of the way along the front wall.

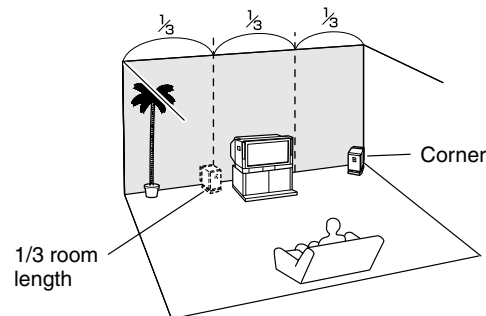

To find the best position for your subwoofer, while playing a movie or some music with a good bass sound,

experiment by placing your subwoofer at various positions within your room and choose the one that provides the most satisfying results at your listening position.

Using Dipole Speakers

You can use dipole speakers for the surround left and right and surround back left and right speakers. Dipole speakers output the same sound in two directions.

Dipole speakers typically have an arrow printed on them to indicate how they should be positioned. The surround left and right dipolar speakers should be positioned so that their arrows point toward the TV/screen, while the surround left and right dipolar speakers should be positioned so that their arrows point toward each other, as shown.

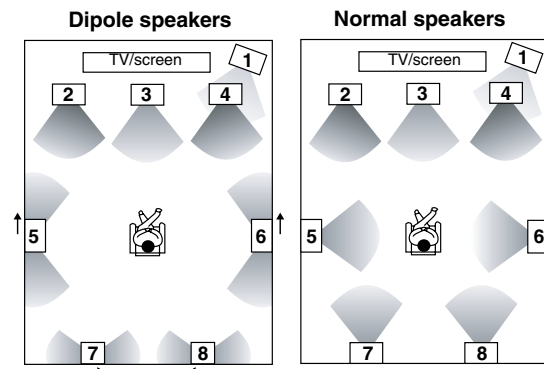

1. Subwoofer
2. Front left speaker
3. Center speaker
4. Front right speaker
5. Surround left speaker

6. Surround right speaker
7. Surround back left speaker
8. Surround back right speaker

Attaching the Speaker Labels

The DTR-8.4's positive (+) speaker terminals are color-coded for ease of identification. (The negative (-) speaker terminals are all black.)

Speaker terminal	Color
Front left	White
Front right	Red
Center	Green
Surround left	Blue
Surround right	Gray
Surround back/Zone 2 left	Brown
Surround back/Zone 2 right	Tan

The supplied speaker labels are also color-coded and you should attach them to the positive (+) side of each speaker cable in accordance with the above table. All you need to do then is to match the color of each label to the corresponding speaker terminal.



Connecting the DTR-8.4—Continued

Connecting Your Speakers

Read the following before connecting your speakers:

- Disconnect the power cord from the wall outlet.
- Read the instructions supplied with your speakers.
- Pay close attention to speaker wiring polarity. In other words, connect positive (+) terminals to only positive (+) terminals, and negative (–) terminals to only negative (–) terminals. If you get them the wrong way around, the sound will be out of phase and will sound unnatural.
- Only connect speakers with an impedance of between 4 and 16 ohms. If the impedance of any one speaker is between 4 and 6 ohms, be sure to select the 4 ohms setting on the DTR-8.4 (see page 40).
- Unnecessarily long, or very thin speaker cables may affect the sound quality and should be avoided.
- Be careful not to short the positive and negative wires. Doing so may damage the DTR-8.4.
- Don't connect more than one cable to each speaker terminal. Doing so may damage the DTR-8.4.
- If you want to connect a single speaker instead of a pair, don't connect it to the left and right terminals.

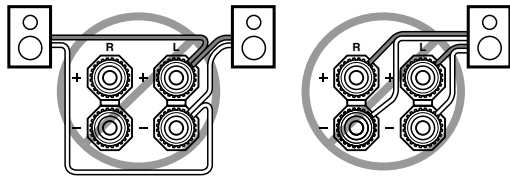
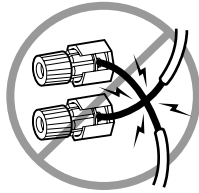

The following illustration shows which speaker should be connected to each pair of terminals.

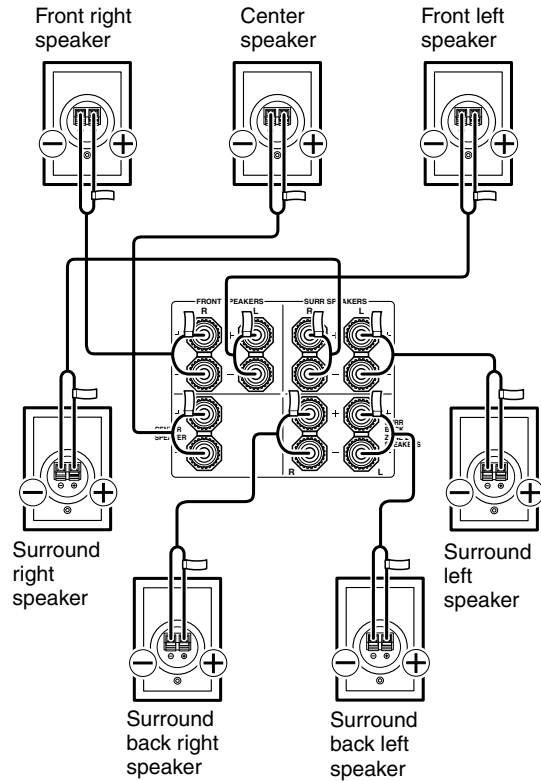

Connecting the Speaker Cables

- 1 Strip about 5/8" (15 mm) of insulation from the ends of the speaker cables, and twist the bare wires tightly, as shown.**

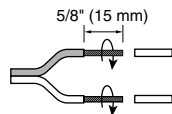

- 2 Unscrew the terminal.**



- 3 Fully insert the bare wires.**

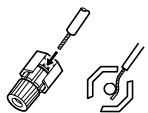

- 4 Screw the terminal tight.**



Connecting a Powered Subwoofer

Using a suitable cable, connect the DTR-8.4's PRE OUT SUB output to the powered subwoofer's input, as shown. If your subwoofer is unpowered and you're using an external amp, connect the PRE OUT SUB output to the amp's input.

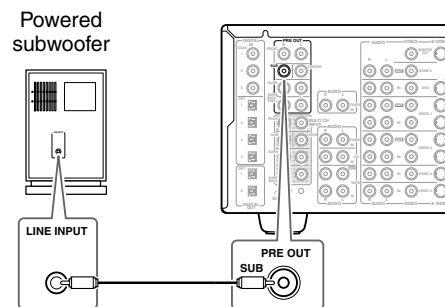

Connecting the DTR-8.4—Continued

Connecting Antenna

This chapter explains how to connect the supplied indoor FM antenna and AM loop antenna, and how to connect commercially available outdoor FM and AM antennas. The DTR-8.4 won't pick up any radio signals without any antenna connected, so you must connect the antenna to use the tuner.

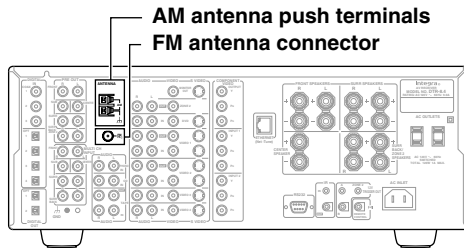

Connecting the Indoor FM Antenna

The supplied indoor FM antenna is for indoor use only.

1 Attach the FM antenna, as shown.

■ U.S.A. and Canadian Models

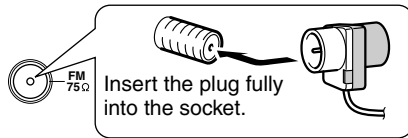

■ Australian Model

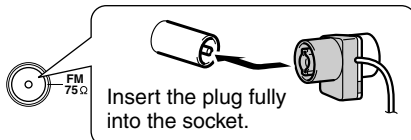

Once your DTR-8.4 is ready for use, you'll need to tune into an FM radio station and adjust the position of the FM antenna to achieve the best possible reception.

2 Use thumbtacks or something similar to fix the FM antenna into position.

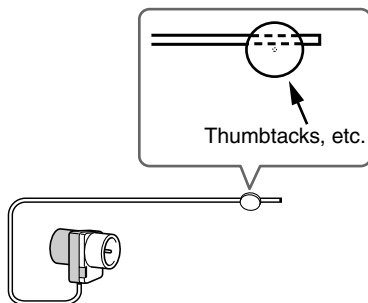

Caution: Be careful that you don't injure yourself when using thumbtacks.

If you cannot achieve good reception with the supplied indoor FM antenna, try a commercially available outdoor FM antenna instead (see page 25).

Connecting the AM Loop Antenna

The supplied indoor AM loop antenna is for indoor use only.

1 Assemble the AM loop antenna, inserting the tabs into the base, as shown.

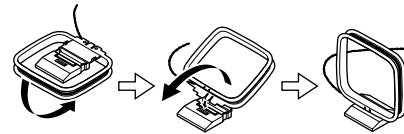

2 Connect both wires of the AM loop antenna to the AM push terminals, as shown.

(The antenna's wires are not polarity sensitive, so they can be connected either way around).

Make sure that the wires are attached securely and that the push terminals are gripping the bare wires, not the insulation.

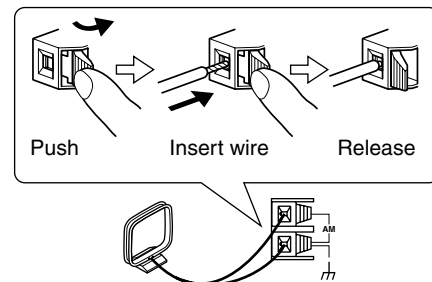

Once your DTR-8.4 is ready for use, you'll need to tune into an AM radio station and adjust the position of the AM antenna to achieve the best possible reception.

Keep the antenna as far away as possible from your DTR-8.4, TV, speaker cables, and power cords.

If you cannot achieve good reception with the supplied indoor AM loop antenna, try using it with a commercially available outdoor AM antenna (see page 25).

Connecting the DTR-8.4—Continued

Connecting an Outdoor FM Antenna

If you cannot achieve good reception with the supplied indoor FM antenna, try a commercially available outdoor FM antenna instead.

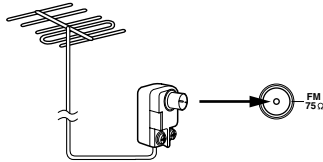

Notes:

- Outdoor FM antennas work best outside, but usable results can sometimes be obtained when installed in an attic or loft.
- For best results, install the outdoor FM antenna well away for tall buildings, preferably with a clear line of sight to your local FM transmitter.
- Outdoor antenna should be located away from possible noise sources, such as neon signs, busy roads, etc.
- For safety reasons, outdoor antenna should be situated well away from power lines and other high-voltage equipment.
- Outdoor antenna must be grounded in accordance with local regulations to prevent electrical shock hazards.

■ Using the 75/300-ohm Antenna Adapter (Australian model only)

The 75/300-ohm antenna adapter can be used to connect an FM antenna using either 75-ohm coaxial cable or 300-ohm twin-core flat cable.

■ Connecting 300-ohm Flat Cable

1 Using a screwdriver, loosen the two screws on the adapter, wrap the bare wires around the screws, and then retighten them, as shown.

2 Plug the adapter into the 75 Ω socket.

■ Connecting 75-ohm Coaxial Cable

1 Strip and prepare the 75 ohm coaxial cable, as shown.

2 Using your fingernails or a small screwdriver, lever the adapter's tabs outward and remove the cover, as shown.

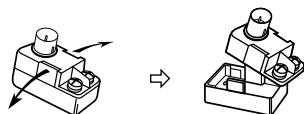

3 Move the small wire inside the adapter from position A to position B, as shown.

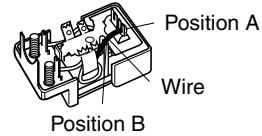

4 Insert the central conductor (1), as shown, and use a small pair of pliers to clamp the shielding and outer insulation sections of the cable (2), as shown.

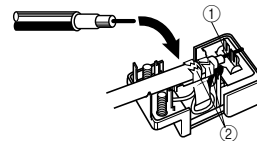

Make sure the shielding is not touching the central conductor.

5 Refit the adapter's cover, and then plug the adapter into the 75 Ω socket.

■ Using a TV/FM Antenna Splitter

It's best not to use the same antenna for both FM and TV reception, as this can cause interference problems. If circumstances demand it, use a TV/FM antenna splitter, as shown.

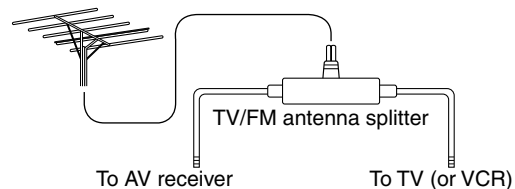

Connecting an Outdoor AM Antenna

If good reception cannot be achieved using the supplied AM loop antenna, an outdoor AM antenna can be used in addition to the loop antenna, as shown.

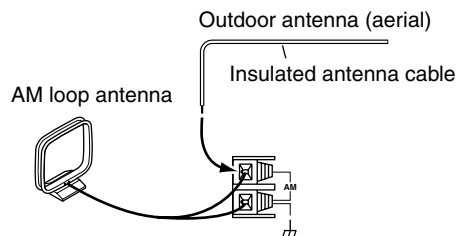

Outdoor AM antennas work best when installed outside horizontally, but good results can sometimes be obtained indoors by mounting horizontally above a window. Note that the AM loop antenna should be left connected.

Outdoor antenna must be grounded in accordance with local regulations to prevent electrical shock hazards.

Connecting the DTR-8.4—Continued

Before Making Any Connections

- Read the manuals supplied with your AV components.
- Don't connect the power cord until you've completed all audio and video connections.

Optical Digital Inputs

The DTR-8.4's optical digital inputs have shutter-type covers that open when an optical plug is inserted, and close when it's removed. Push plugs in all the way.

RCA/phono AV Connection Color Coding

RCA/phono AV connections are usually color coded: red, white, and yellow. Use red plugs to connect right-channel audio inputs and outputs (typically labeled "R"). Use white plugs to connect left-channel audio inputs and outputs (typically labeled "L"). And use yellow plugs to connect composite video inputs and outputs.



- Push plugs in all the way to make good connections (loose connections can cause noise or malfunctions).
- To prevent interference, keep audio and video cables away from power cords and speaker cables.

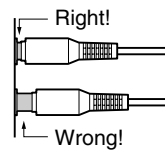

AV Cables & Sockets

Video

Cable	Socket	Description
		Component video separates the luminance (Y) and color difference signals (PR, PB), providing the best picture quality. Some TV manufacturers label their component video sockets differently.
		S-Video separates the luminance and color signals and provides better picture quality than composite video.
		Composite video is the most common video connection format and is found on virtually all TVs, VCRs, and video equipment.

Audio

Cable	Socket	Description
		Offers the best sound quality and allows you to enjoy surround sound (e.g., Dolby Digital, DTS). The audio quality is the same as for coaxial.
		Offers the best sound quality and allows you to enjoy surround sound (e.g., Dolby Digital, DTS). The audio quality is the same as for optical.
		This cable carries analog audio. It's the most common connection format for analog audio, and can be found on virtually all AV components.
		This cable carries multichannel analog audio and it's typically used to connect DVD players with individual 5.1/7.1 analog audio outputs. Several normal analog audio cables can be used as an alternative to a multichannel cable.

Connecting the DTR-8.4—Continued

Connecting Your TV or Projector

The DTR-8.4 offers several connection formats for compatibility with a wide range of AV equipment. The format you choose will depend on the formats supported by your AV components. Use the following section as a guide.

Video Connection Formats

Video equipment can be connected to the DTR-8.4 using the following video connection formats: composite video, S-Video, or component video, the latter offering the best picture quality.

The following diagram shows that composite video input signals are output by composite video and S-Video outputs, and that S-Video input signals are output by S-Video and composite video outputs.

If you connect a video source to a component video input, you'll need to connect your TV or projector to the component video output. Normally, component video input #1 or #2 feeds the component video output. However, you can configure the DTR-8.4 to output composite video and S-Video input signals as component video (see "Component Video Setup" on page 47).

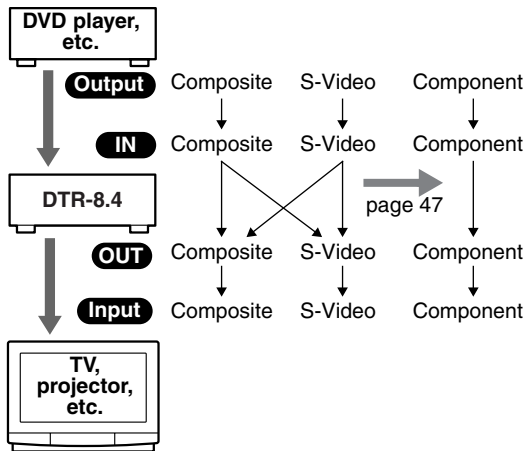

Depending on the type of video input on your TV, choose one of the following connection methods.

Using Composite Video

Use a composite video cable to connect the DTR-8.4's VIDEO MONITOR OUT to a composite video input on your TV, as shown.

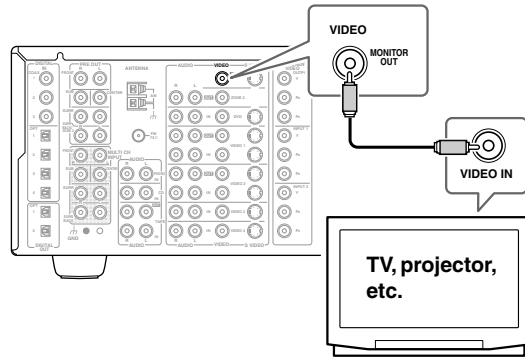

Using S-Video

Use an S-Video cable to connect the DTR-8.4's S VIDEO MONITOR OUT to an S-Video input on your TV, as shown.

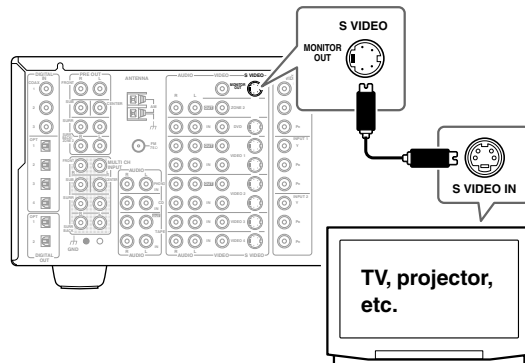

Using Component Video

Use a component video cable to connect the DTR-8.4's COMPONENT VIDEO OUTPUT to a component video input on your TV, as shown.

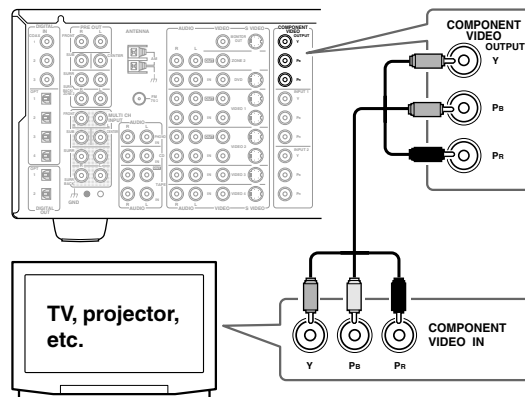

Connecting the DTR-8.4—Continued

Connecting a DVD Player

Video Connections

You only need to use one of the following connection methods.

■ Using Composite Video

Use a composite video cable to connect the DTR-8.4's VIDEO DVD IN to the composite video output on your DVD player, as shown.

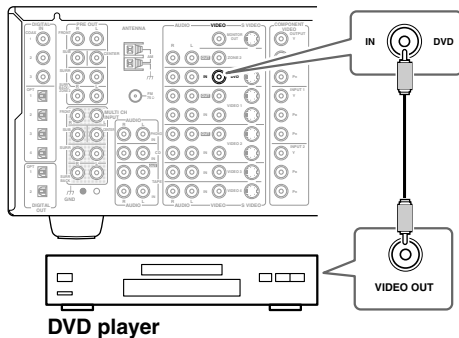

■ Using S-Video

Use an S-Video cable to connect the DTR-8.4's S VIDEO DVD IN to the S-Video output on your DVD player, as shown.

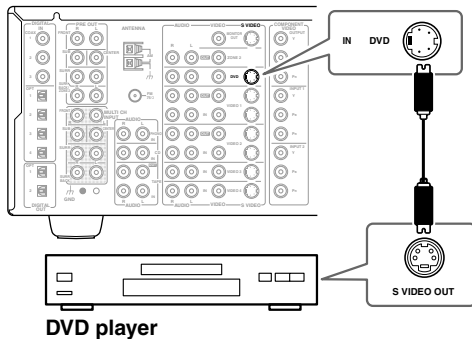

■ Using Component Video

Use a component video cable to connect the DTR-8.4's COMPONENT VIDEO INPUT 1 to the component video output on your DVD player, as shown.

- Your TV must also be connected via component video.

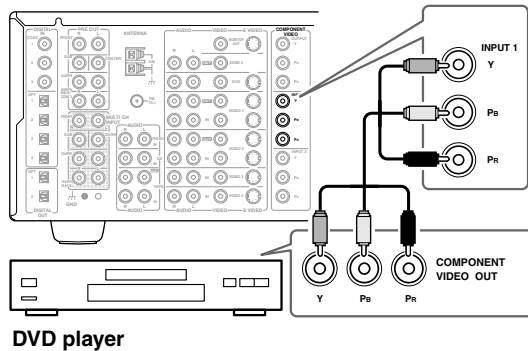

Audio Connections

■ Using Coaxial or Optical Connections

- Use a coaxial digital audio cable to connect the DTR-8.4's DIGITAL IN COAX 1 to the coaxial output on your DVD player, as shown.

OR

- Use an optical digital audio cable to connect the DTR-8.4's DIGITAL IN OPT 1, 2, 3, or 4 to the optical output on your DVD player, as shown.

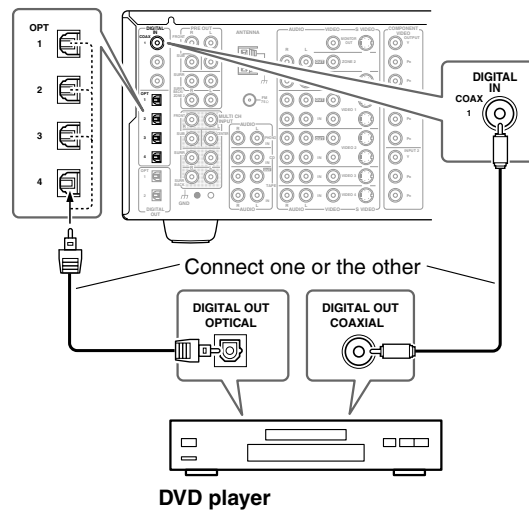

Initially, the COAX 1 digital input is assigned to the DVD input source. If you connect your DVD player to a different digital input, you'll need to reassign the DVD input source (see page 45).

■ Using Analog Connections

Even if your DVD player is connected digitally (coaxial or optical), to use **RI**, or to record audio from your DVD player, you'll need to make analog connections as well.

Use an analog audio cable (RCA/phono) to connect the DTR-8.4's AUDIO DVD IN L/R inputs to the analog audio outputs on your DVD player, as shown.

If your DVD player has left, right, and multichannel outputs, be sure to use the left and right outputs.

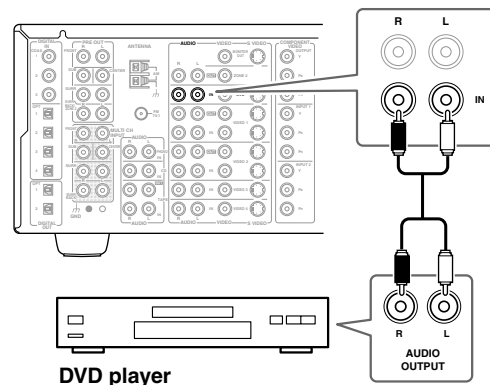

Connecting the DTR-8.4—Continued

■ Using Multichannel Connections

If your player supports multichannel audio formats such as DVD-Audio, and it has multichannel analog audio outputs, you can enjoy DVD-Audio playback.

Use a multichannel analog audio cable (RCA/phono) to connect the DTR-8.4's MULTI CH INPUT FRONT L/R, SUB, CENTER, SURR L/R, and SURR BACK L/R to the 5.1 or 7.1 analog outputs on your DVD player, as shown. Alternatively, use several analog audio cables (RCA/phono).

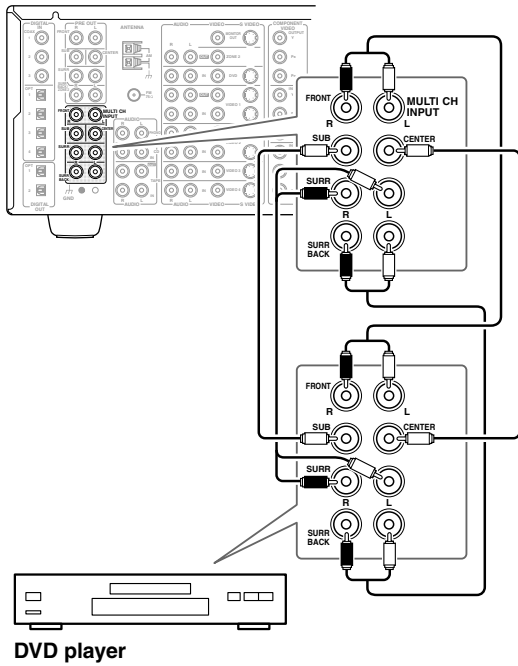

Connecting a VCR for Playback

You can play a video from a VCR via the DTR-8.4.

Video Connections

- Use an S-Video cable to connect the DTR-8.4's S VIDEO VIDEO 1 IN to the S-Video output on your VCR, as shown.

OR

- Use a composite video cable to connect the DTR-8.4's VIDEO VIDEO 1 IN to a composite video output on your VCR, as shown.

An S-Video connection provides better picture quality than a composite video connection.

Audio Connections

- Use an analog audio cable (RCA/phono) to connect the DTR-8.4's AUDIO VIDEO 1 IN L/R inputs to the analog audio outputs on your VCR, as shown.

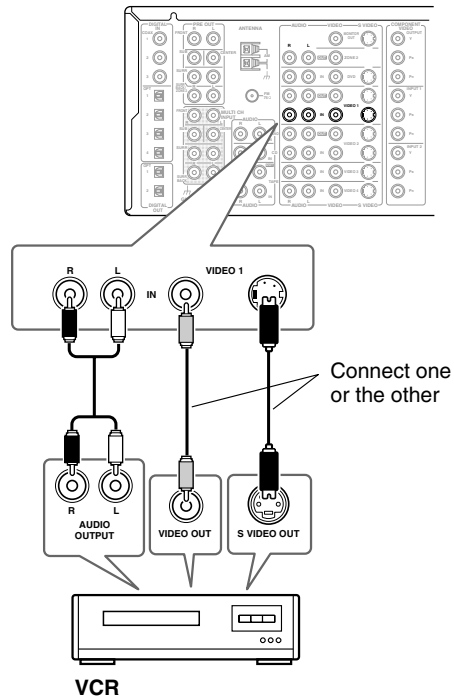

Connecting the DTR-8.4—Continued

Connecting a D-VHS VCR for Playback

Video Connections

Use a component video cable to connect the DTR-8.4's COMPONENT VIDEO INPUT 2 to the component video output on your D-VHS VCR, as shown.

Your TV must also be connected via component video. A component video connection provides better picture quality than an S-Video connection.

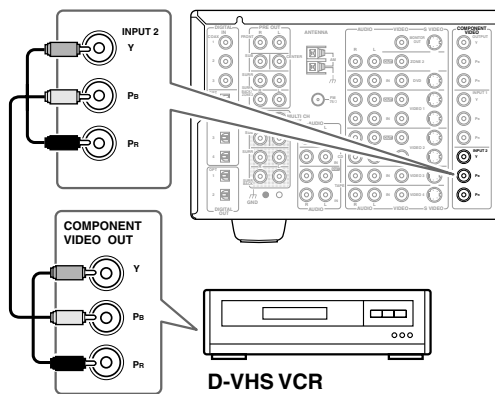

Audio Connections

- Use an optical digital audio cable to connect the DTR-8.4's DIGITAL IN OPT 1, 2, 3, or 4 to the optical output on your D-VHS VCR, as shown.

OR

- Use a coaxial digital audio cable to connect the DTR-8.4's DIGITAL IN COAX 2 or 3 to the coaxial output on your D-VHS VCR, as shown.

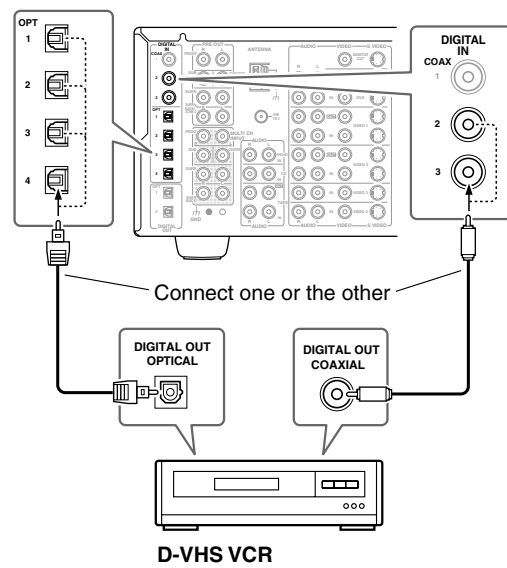

You might need to change the digital input-to-input source assignments (page 45).

Connecting the DTR-8.4—Continued

Connecting a VCR for Recording

This section shows how to connect a VCR for recording from a TV or another VCR.

Video Connections

- Use an S-Video cable to connect the DTR-8.4's S VIDEO VIDEO 1 OUT to an S-Video input on your recording VCR. Use another S-Video cable to connect the DTR-8.4's S VIDEO VIDEO 3 IN to an S-Video output on your TV or playback VCR, as shown.

OR

- Use a composite video cable to connect the DTR-8.4's VIDEO VIDEO 1 OUT to a composite video input on your recording VCR. Use another composite video cable to connect the DTR-8.4's VIDEO VIDEO 3 IN to a composite video output on your TV or playback VCR, as shown.

Audio Connections

- Use an analog audio cable (RCA/phono) to connect the DTR-8.4's AUDIO VIDEO 1 L/R OUTs to the audio inputs on your recording VCR.
- Use an analog audio cable (RCA/phono) to connect the DTR-8.4's AUDIO VIDEO 3 L/R IN inputs to the audio outputs on your TV or playback VCR.

Playback from the Recording VCR

To enjoy playback from the recording VCR through the DTR-8.4, use an S-Video cable to connect the DTR-8.4's S VIDEO VIDEO 1 IN input to an S-Video output on your recording VCR, or use a composite video cable to connect the DTR-8.4's VIDEO VIDEO 1 IN input to a composite video output on your recording VCR, and use an analog audio cable (RCA/phono) to connect the DTR-8.4's AUDIO VIDEO 1 L/R IN inputs to the audio outputs on your recording VCR.

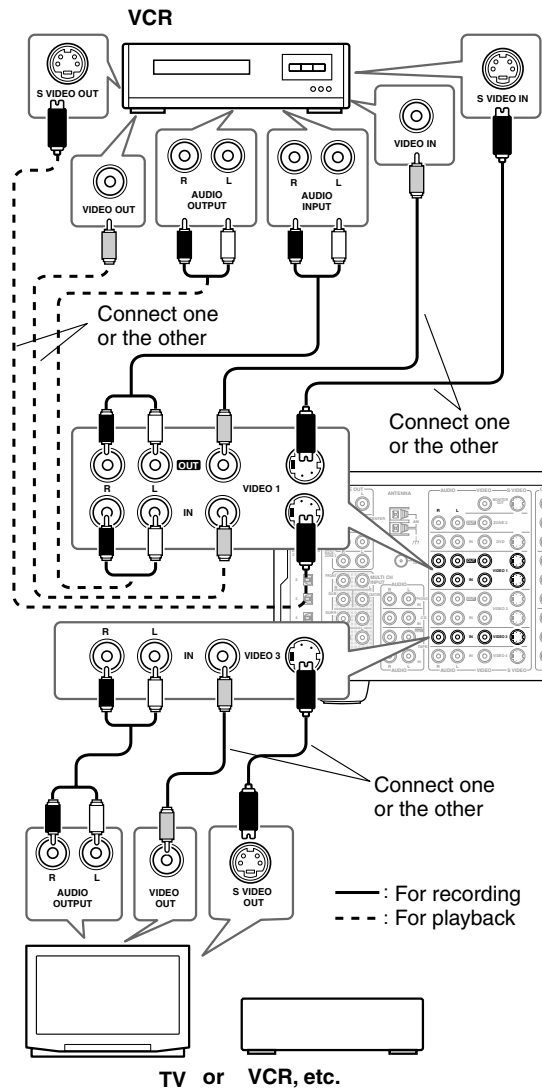

Notes:

- The DTR-8.4 must be turned On for recording. Recording is not possible while it's in Standby mode.
- If you want to record directly from your TV or playback VCR to your recording VCR without going through the DTR-8.4, connect your TV/VCR's audio and video outputs directly to your recording VCR's AV inputs. See the manuals supplied with your TV and VCR for details.
- Video signals connected to composite video inputs can only be recorded via composite video outputs. If your TV and video playback components are connected via composite video, you must connect your recording VCR via composite video as well. Similarly, video signals connected to S-Video inputs can only be recorded via S-Video outputs. If your TV and video playback components are connected via S-Video, you must connect your recording VCR via S-Video as well.

Connecting the DTR-8.4—Continued

Connecting Other Video Sources— TV, Satellite, Cable, Set-top box, LD Player, etc.

Video Connections

You only need to use one of the following connection methods.

If you just want to listen to the audio from your TV via the DTR-8.4 with surround sound, no video connections are necessary, just make an audio connection.

■ Using Composite Video

Use a composite video cable to connect the DTR-8.4's VIDEO VIDEO 3 or 4 IN to the composite video output on your video source, as shown.

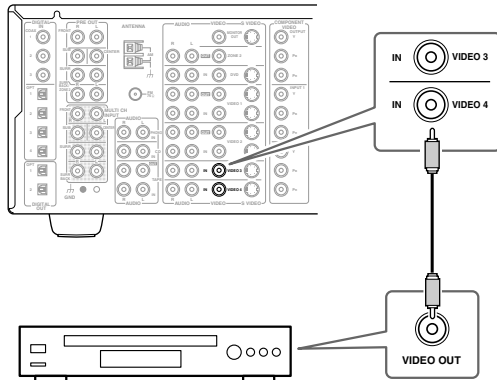

Satellite, cable, set-top box, LD player, etc.

■ Using S-Video

Use an S-Video cable to connect the DTR-8.4's S VIDEO VIDEO 3 or 4 IN to the S-Video output on your video source, as shown.

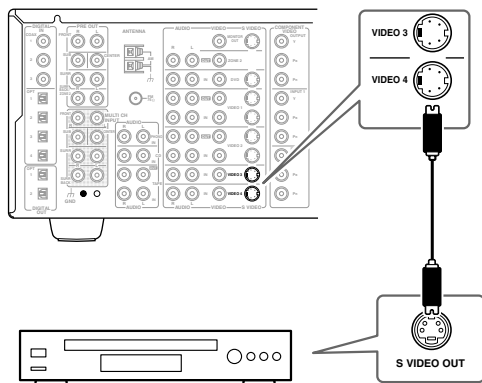

Satellite, cable, set-top box, LD player, etc.

■ Using Component Video

Use a component video cable to connect the DTR-8.4's COMPONENT VIDEO INPUT 1 or 2 to the component video output on your video source, as shown.

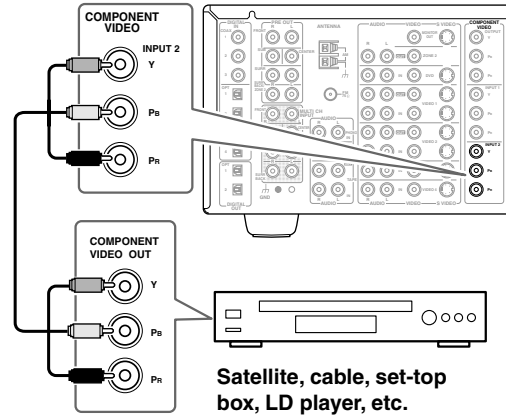

Audio Connections

■ Using Coaxial or Optical Connections

- Use a coaxial digital audio cable to connect the DTR-8.4's DIGITAL IN COAX , 2, or 3 to the coaxial output on your video source, as shown.

OR

- Use an optical digital audio cable to connect the DTR-8.4's DIGITAL IN OPT 3 to the optical output on your video source, as shown.

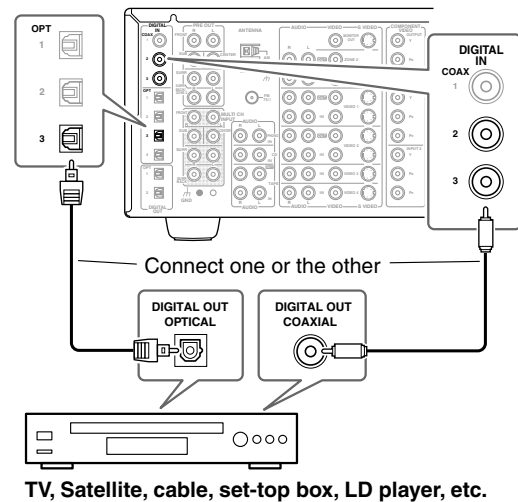

TV, Satellite, cable, set-top box, LD player, etc.

Notes:

- You may need to change the digital input-to-input source assignments (see page 45).
- To connect the DTR-8.4 to an LD player's AC-3RF output, you need a commercially available demodulator.

Connecting the DTR-8.4—Continued

■ Using Analog Connections

If your video source doesn't have digital audio outputs, or you want to record from it, you'll need to make the following analog audio connections.

Use an analog audio cable (RCA/phono) to connect the DTR-8.4's AUDIO VIDEO 3 or 4 IN L/R inputs to the analog audio outputs on your video source, as shown.

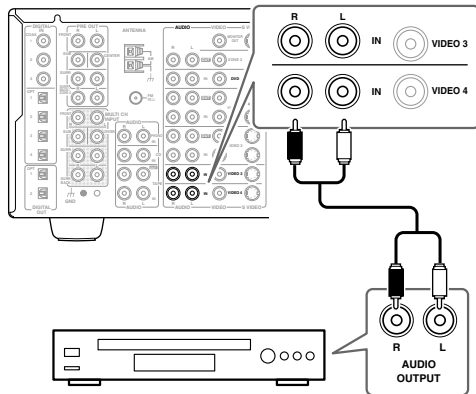

TV, Satellite, cable, set-top box, LD player, etc.

■ Using Composite Video

Use a composite video cable to connect the DTR-8.4's VIDEO 5 INPUT VIDEO input to the composite video output on your camcorder, games console, etc., as shown.

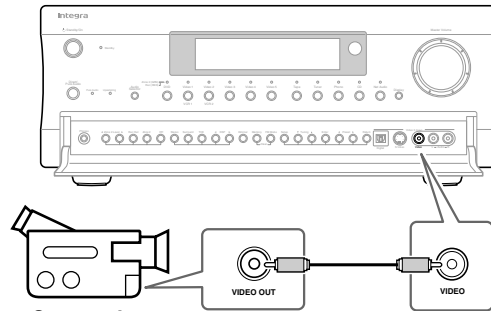

Camcorder, games console, etc.

Audio Connections

Use an analog audio cable (RCA/phono) to connect the DTR-8.4's VIDEO 5 INPUT AUDIO L/R inputs to the analog audio outputs on your camcorder, games console, etc., as shown.

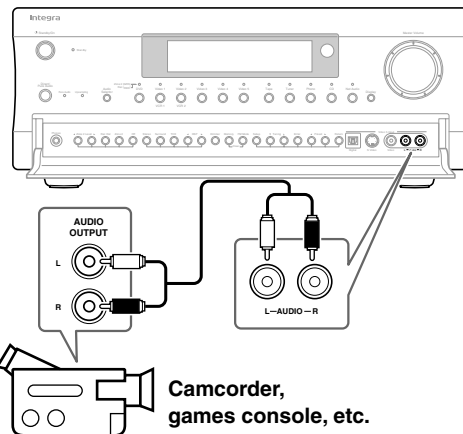

Camcorder, games console, etc.

Connecting a Camcorder, Games Console, etc.

Video Connections

You only need to use one of the following connection methods.

■ Using S-Video

Use an S-Video cable to connect the DTR-8.4's VIDEO 5 INPUT S VIDEO input to the S-Video output on your camcorder, games console, etc., as shown.

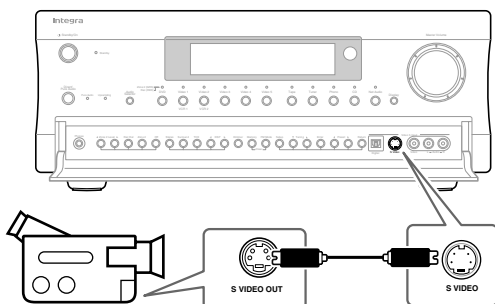

Camcorder, games console, etc.

If your camcorder, games console, etc., has an optical digital audio output, use an optical digital audio cable to connect it to the DTR-8.4's VIDEO 5 INPUT DIGITAL input, as shown.

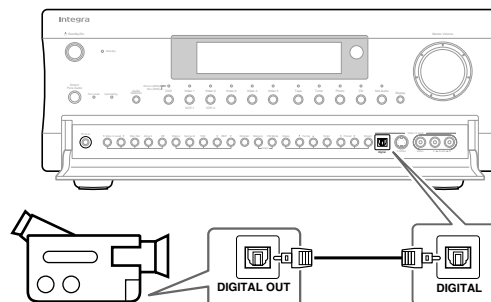

Camcorder, games console, etc.

Connecting the DTR-8.4—Continued

Connecting a CD Player

■ Using Optical or Coaxial Connections

- Use an optical digital audio cable to connect the DTR-8.4's DIGITAL IN OPT 1 to the optical output on your CD player, as shown.

OR

- Use a coaxial digital audio cable to connect the DTR-8.4's DIGITAL IN COAX 2, or 3 to the coaxial output on your CD player, as shown.

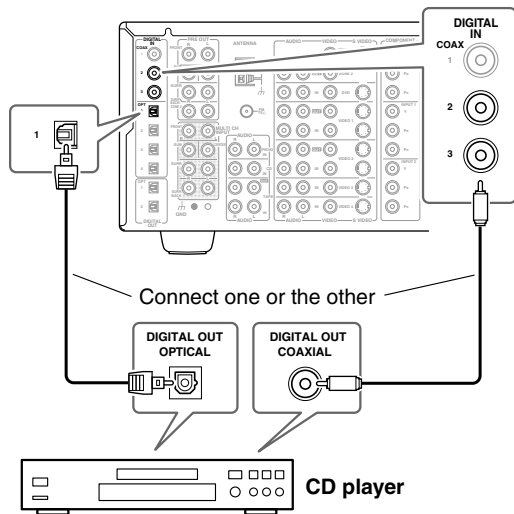

Initially, the DIGITAL IN OPT 1 input is assigned to the CD input source. If you connect your CD player to a different digital input, you'll need to assign that input to the CD input source (see page 45).

■ Using Analog Connections

Even if your CD player is connected digitally (coaxial or optical), to use **RI**, or to record audio from your CD player, you'll need to make analog audio connections as well.

Use an analog audio cable (RCA/phono) to connect the DTR-8.4's AUDIO CD IN L/R inputs to the analog audio outputs on your CD player, as shown.

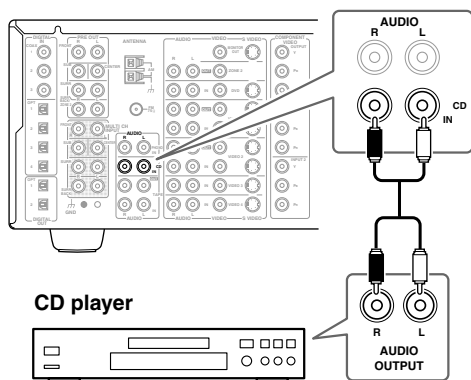

Connecting a Cassette Recorder

Use an analog audio cable (RCA/phono) to connect the DTR-8.4's AUDIO TAPE IN L/R inputs to the cassette recorder's outputs, and use another analog audio cable (RCA/phono) to connect the DTR-8.4's AUDIO TAPE OUT L/R outputs to the cassette recorder's inputs, as shown.

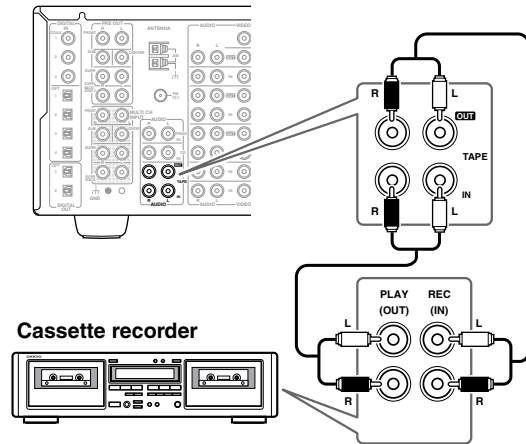

Connecting a DAT, CD, or MD Recorder

You can connect a DAT, CD, or MD recorder instead of a cassette recorder.

■ Analog Connections

Use an analog audio cable (RCA/phono) to connect the DTR-8.4's AUDIO TAPE IN L/R inputs to the recorder's outputs, and use another analog audio cable (RCA/phono) to connect the DTR-8.4's AUDIO TAPE OUT L/R outputs to the recorder's inputs, as shown.

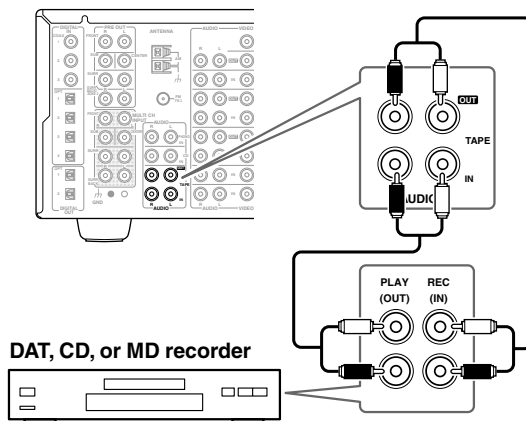

Connecting the DTR-8.4—Continued

■ Using Coaxial or Optical Connections (playback only)

- Use a coaxial digital audio cable to connect the DTR-8.4's DIGITAL IN COAX 2, or 3 to the coaxial output on your recorder, as shown.

OR

- Use an optical digital audio cable to connect the DTR-8.4's DIGITAL IN OPT 2 to the optical output on your recorder, as shown.

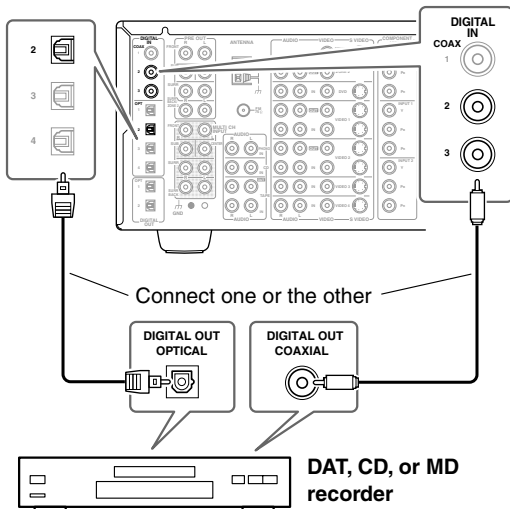

You might need to change the digital input-to-input source assignments (page 45).

■ Digital Recording

If your recorder has a digital input, by connecting it to one of the DTR-8.4's DIGITAL OUTs you can record digitally. Since the DTR-8.4 does not convert analog input signals to digital and vice versa, only input signals connected to a DIGITAL IN can be recorded digitally.

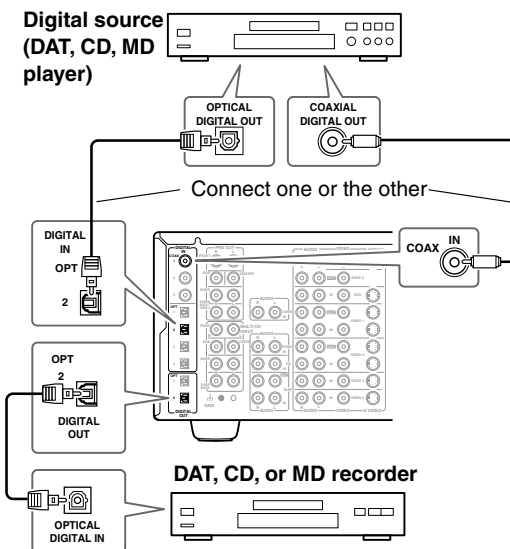

Note:

Don't connect the recorder's digital output to the DTR-8.4 when the recorder's digital input is connected to one of the DTR-8.4's digital outputs. Doing so may create a signal loop and cause a malfunction.

Connecting a Turntable

The DTR-8.4's phono inputs are for use with moving magnet (MM) type cartridges.

Use an analog audio cable (RCA/phono) to connect the DTR-8.4's AUDIO PHONO IN L/R inputs to the audio outputs on your turntable, as shown.

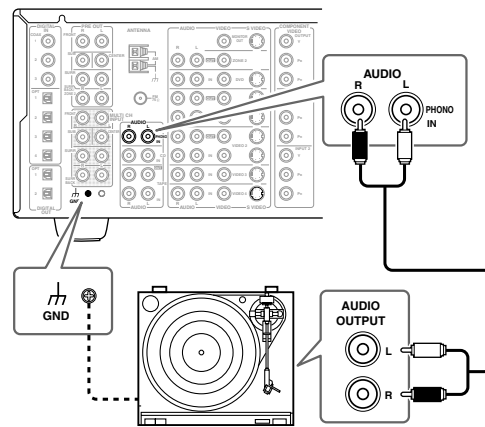

Notes:

- If your turntable has a ground wire, connect it to the GND screw on the DTR-8.4. With some turntables, connecting the ground wire may cause hum, in which case it should be disconnected.
- If your turntable has a moving coil (MC) type cartridge, you'll need a commercially available MC phono preamp. Connect the phono preamp to your turntable, and then connect the phono preamp to the DTR-8.4's AUDIO PHONO IN L/R inputs.

Connecting the DTR-8.4—Continued

Connecting a Power Amp

If you want to use the DTR-8.4 as a preamp and connect an external power amp, for example, a multichannel power amp that's more powerful than the DTR-8.4's built-in power amp, you can connect it to the PRE OUT outputs. In this case, you should connect all speakers and the subwoofer to the external power amp.

If you have a powered subwoofer, connect it to the DTR-8.4's PRE OUT SUB output.

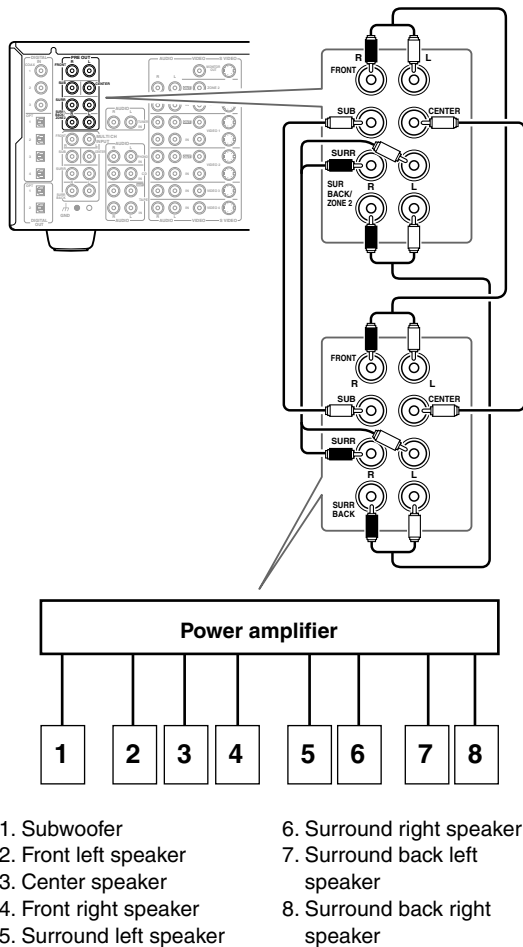

Connecting RI Components

With **RI** (Remote Interactive) you can control your **RI**-compatible Integra/Onkyo CD player, DVD player, and so on with the DTR-8.4's remote controller, and use the following special **RI** functions:

- To use **RI**, you must make an **RCA/phono analog audio connection between the DTR-8.4 and the other AV components, even if they are connected digitally.**

Auto Power On/Standby

When you start playback on an AV component connected via **RI**, if the DTR-8.4 is in Standby, it will turn on and select that AV component as the input source automatically. Similarly, when the DTR-8.4 is set to Standby, all components connected via **RI** also enter Standby. This function will not work if a component's power cord is connected to an AC OUTLET on the DTR-8.4.

Direct Change

When playback is started on an AV component connected via **RI**, the DTR-8.4 automatically selects that AV component as the input source.

Remote Operation function

With the DTR-8.4's remote controller, you can operate **RI**-compatible Integra/Onkyo components.

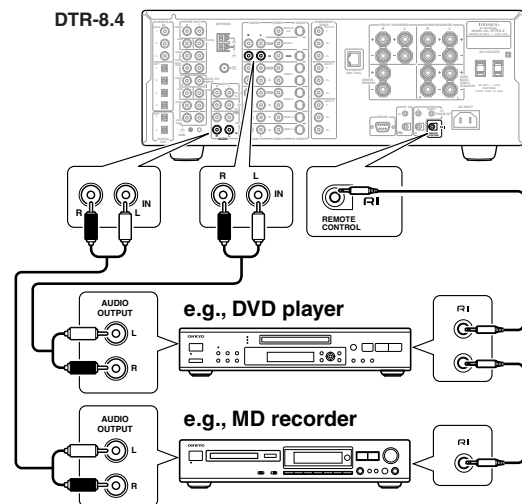

Notes:

- Push plugs in all the way to make good connections.
- Use only **RI** cables for **RI** connections. An **RI** cable is not included with the DTR-8.4.
- Some AV components have two **RI** sockets, you can connect either one to the DTR-8.4. The other is for connecting additional **RI**-compatible components.
- Connect the DTR-8.4's **RI** socket to only Integra/Onkyo AV components. Connecting to other manufacturer's AV components may cause them to malfunction.
- Some components may not support all **RI** functions. Refer to the manuals supplied with your components.

Connecting the DTR-8.4—Continued

Connecting the Power Cords of Other Components

The DTR-8.4 has AC outlet(s) on its rear panel that can be used to connect the power cords of AV components that you intend to use with the DTR-8.4. These components can then be left turned on so that they turn on and off as and when the DTR-8.4 is turned on and set to Standby.

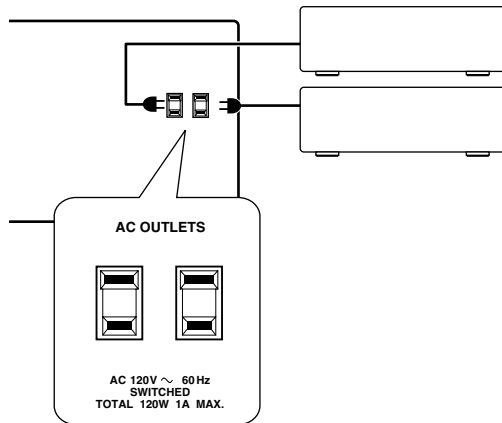

Caution:

- Make sure that the total capacity of the components that you connect to the AC OUTLETS does not exceed the stated capacity (e.g., TOTAL 120 W).

Note:

- Integra/Onkyo components with **RI** sockets should be connected to regular wall outlets.
- The number of AC OUTLETS, connector type, and total capacity will depend on the country in which you purchased the DTR-8.4.

Connecting the RS232 Port

This port can be used to connect an external controller for controlling the DTR-8.4.

Connecting the Power Cord

Notes:

- Before connecting the power cord, connect all of your speakers and AV components.
- Turning on the DTR-8.4 may cause a momentary power surge that might interfere with other electrical equipment on the same circuit. If this is a problem, plug the DTR-8.4 into a different branch circuit.
- Do not use a power cord other than the one supplied with the DTR-8.4. The supplied power cord is designed exclusively for use with the DTR-8.4 and should not be used with any other equipment.
- Never disconnect the power cord from the DTR-8.4 while the other end is still plugged into a wall outlet. Doing so may cause an electric shock. Always disconnect the power cord from the wall outlet first, and then the DTR-8.4.

- 1** Connect the supplied power cord to the DTR-8.4's AC INLET.
- 2** Plug the power cord into an AC wall outlet.
The Standby indicator lights up.

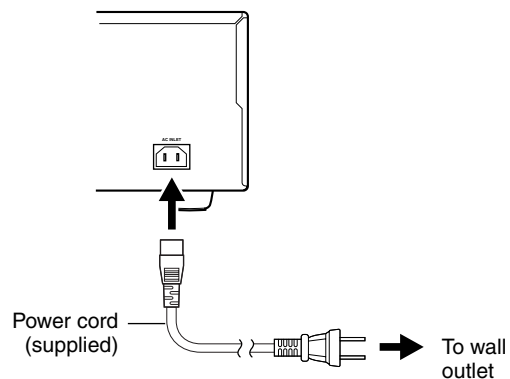

Connecting the DTR-8.4—Continued

Turning On the DTR-8.4

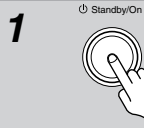
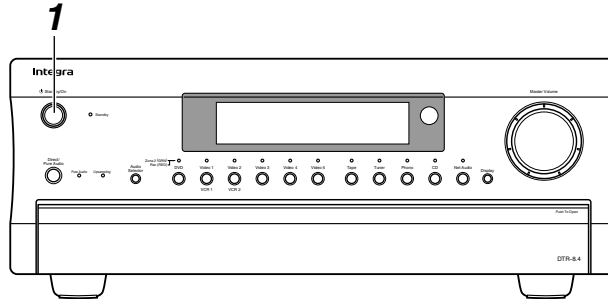

1 Press the [Standby/On] button to turn on the DTR-8.4.
 The display lights up and the Standby indicator goes off.
 Press the Standby/On button again to enter Standby.

Note:

Turning on the DTR-8.4 may cause a momentary power surge that might interfere with other electrical equipment on the same circuit. If this is a problem, plug the DTR-8.4 into a different branch circuit.

Turning On the DTR-8.4 with the Remote Controller

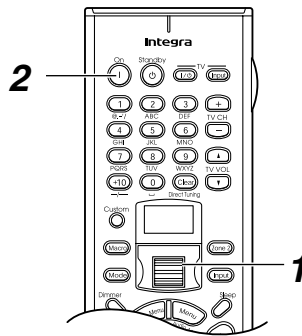

The DTR-8.4 must be in Standby mode for the following procedure to work.



1 Press the scroll wheel.
 “AMP” appears on the remote controller’s display. This is the mode for controlling the DTR-8.4.

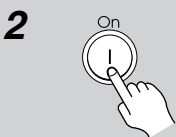

2 Press the [On] button to turn on the DTR-8.4.
 To set the DTR-8.4 to Standby, press the [Standby] button.

Note:

- Any components connected via **RI** will also be turned on when the remote controller’s [On] button is pressed again.

Basic Setup

This chapter explains the settings that you should make before using the DTR-8.4.

About the Onscreen Setup Menus

The onscreen setup menus (OSD) are used to configure the DTR-8.4. They appear on the TV connected to the DTR-8.4, and their large size makes them easy to use.

Settings are divided into two groups: basic and advanced.

Since the advanced menus contain all of the available settings, in this manual, the advanced menus are used in the explanations. All of the Basic menus are included in the Advanced menus.

To get to the Advanced Menu from the Basic Menu, use the Down [▼] button to select "Advanced Menu," and then press the [Enter] button. To get to the Basic Menu from the Advanced Menu, use the Down [▼] button to select "Basic Menu," and then press the [Enter] button.

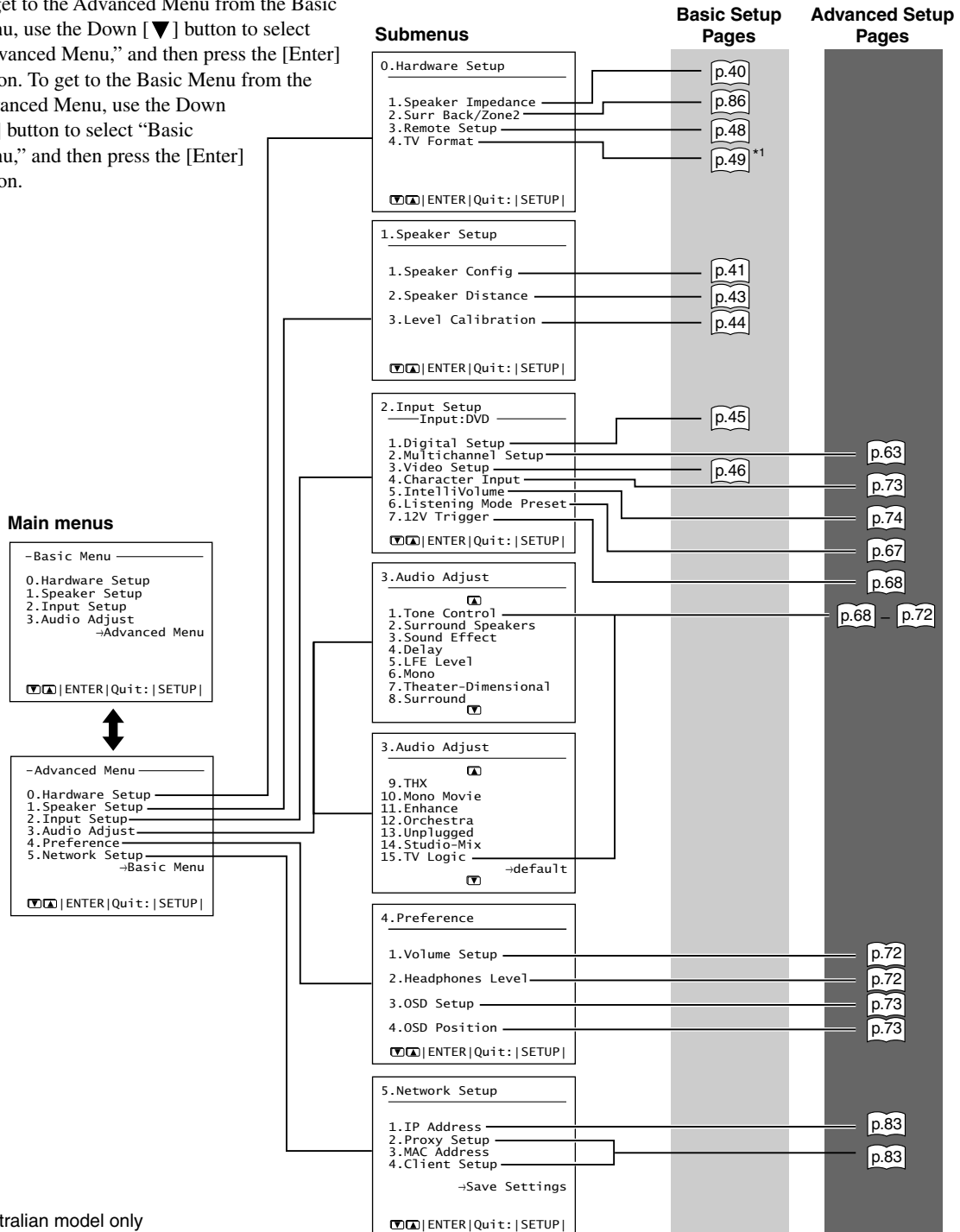

*1 Australian model only

Basic Setup—Continued

Speaker Settings

Speaker Impedance

This section explains how to specify the impedance of your speakers. Check the backs of your speakers or their manuals to determine their impedance.

Note:

Before you change this setting, turn down the volume.

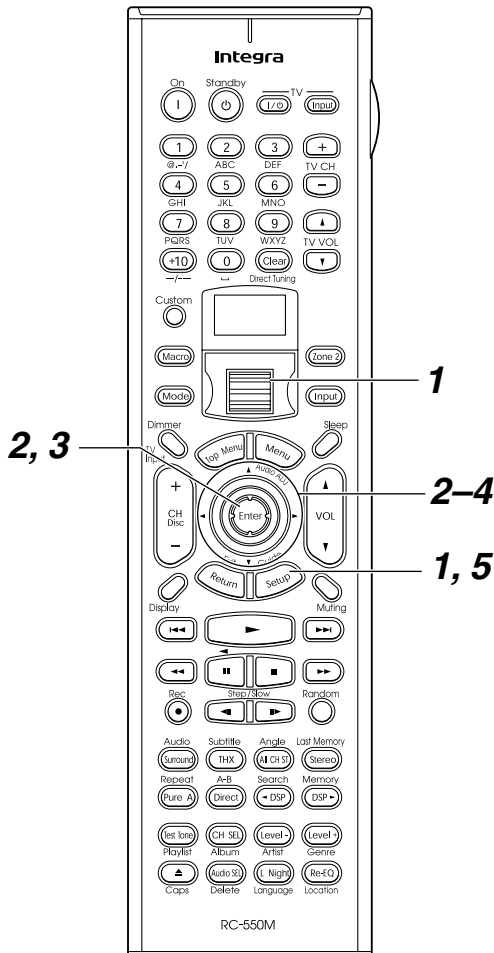

1 Press the scroll wheel, and then press the [Setup] button. The main menu appears onscreen.

2 Use the Up/Down [▲]/[▼] buttons to select “0. Hardware Setup,” and then press the [Enter] button. The Hardware Setup menu appears.

3 Use the Up/Down [▲]/[▼] buttons to select “1. Speaker Impedance,” and then press the [Enter] button. The Speaker Impedance menu appears.

-Advanced Menu-	
0. Hardware Setup	
0-1. Speaker Impedance	
a. Minimum	:6 ohms

4 Use the Left/Right [◀]/[▶] buttons to select:
4 ohms: Select if the impedance of any one speaker is between 4 and 6 ohms.
6 ohms: Select if the impedances of all speakers are between 6 and 16 ohms.

5 Press the [Setup] button. The setup menu closes.

Notes:

- This procedure can also be performed by using the DTR-8.4's [Setup] button, [▲]/[▼]/[◀]/[▶] buttons, and [Enter] button.

Basic Setup—Continued

Speaker Configuration

This section explains how to specify which speakers are connected and their sizes.

For speakers with a cone diameter over 6-1/2 inches (16 cm), specify *large*, and for those with a diameter below this, specify *small*.

If you're using THX-certified speakers, specify Small for all speakers.

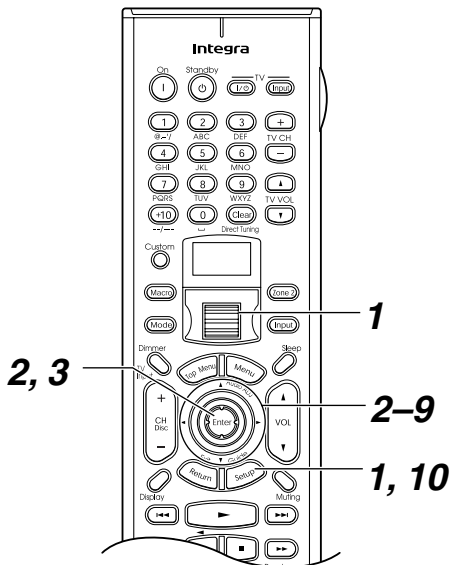
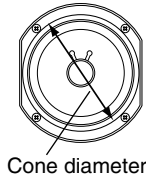

1  **Press the scroll wheel, and then press the [Setup] button.**
The main menu appears onscreen.

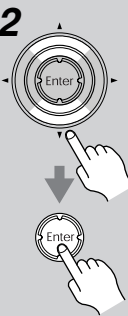
2  **Use the Up/Down [▲]/[▼] buttons to select “1. Speaker Setup,” and then press the [Enter] button.**
The Speaker Setup menu appears.

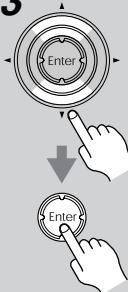
3  **Use the Up/Down [▲]/[▼] buttons to select “1. Speaker Config,” and then press the [Enter] button.**
The Speaker Config menu appear.

-Advanced Menu-----

1. Speaker Setup

1-1. Speaker Config

a. Subwoofer :Yes

b. Front :Small

c. Center :Small

d. Surround :Small

e. Surr Back :Small

f. Crossover:80Hz(THX)

Quit: |SETUP|

4  **Use the Up/Down [▲]/[▼] buttons to select “a. Subwoofer;” and then use the Left/Right [◀]/[▶] buttons to select:**
Yes: Select if a subwoofer is connected.
No: Select if no subwoofer is connected.

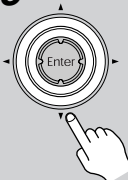
5  **Use the Up/Down [▲]/[▼] buttons to select “b. Front;” and then use the Left/Right [◀]/[▶] buttons to select:**
Small: Select if the front speakers are small.
Large: Select if the front speakers are large.
Note:
• If the Subwoofer setting in step 4 is set to No, this setting is fixed at Large.

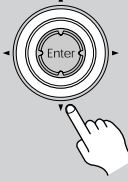
6  **Use the Up/Down [▲]/[▼] buttons to select “c. Center;” and then use the Left/Right [◀]/[▶] buttons to select:**
Small: Select if the center speaker is small.
Large: Select if the center speaker is large.
None: Select if no center speaker is connected.
Note:
• If the Front setting in step 5 is set to Small, the Large option cannot be selected.

Basic Setup—Continued

7



Use the Up/Down [▲]/[▼] buttons to select “d. Surround,” and then use the Left/Right [◀]/[▶] buttons to select:

Small: Select if the surround left and right speakers are small.

Large: Select if the surround left and right speakers are large.

None: Select if no surround left and right speakers are connected.

Note:

- If the Front setting in step 5 is set to Small, the Large option cannot be selected.

8



Use the Up/Down [▲]/[▼] buttons to select “e. Surr Back,” and then use the Left/Right [◀]/[▶] buttons to select:

Small: Select if the surround back left and right speakers are small.

Large: Select if the surround back left and right speakers are large.

None: Select if no surround back left and right speakers are connected.

Notes:

- If the Surround setting in step 7 is set to None, this setting cannot be selected.
- If the Surround setting in step 7 is set to Small, this setting cannot be set to Large.
- If the Surr Back/Zone2 setting is set to Zone 2, this setting cannot be selected (see page 86).

Continue with step 9 in the right column.

Crossover Frequency

9

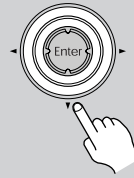

Use the Up/Down [▲]/[▼] buttons to select “f. Crossover,” and then use the Left/Right [◀]/[▶] buttons to select a crossover frequency.

Choose a crossover frequency suitable for your setup. If you’re using a subwoofer, choose a crossover frequency based on the diameter of your front speakers. If you’re not using a subwoofer, use the diameter of any speaker that you specified as Small.

If you’re using THX-certified speakers, select 80 (THX).

Speaker cone diameter	Crossover frequency
Over 12 in. (30 cm)	40Hz
8 to 12 in. (20–30 cm)	60Hz
6-1/2 to 8 in. (16–20 cm)	80Hz (THX)
5-1/4 to 6-1/2 in. (13–16 cm)	100Hz
3-1/2 to 5-1/4 in. (9–13 cm)	120Hz
Under 3-1/2 in. (9 cm)	150Hz

10



Press the [Setup] button.

The setup menu closes.

Notes:



- If the crossover frequency is set to a low value, and the program material doesn’t contain any sounds that are below that frequency, accordingly, the subwoofer will not output much sound.
- This procedure can also be performed by using the DTR-8.4’s [Setup] button, [▲]/[▼]/[◀]/[▶] buttons, and [Enter] button.

Basic Setup—Continued

Speaker Distance

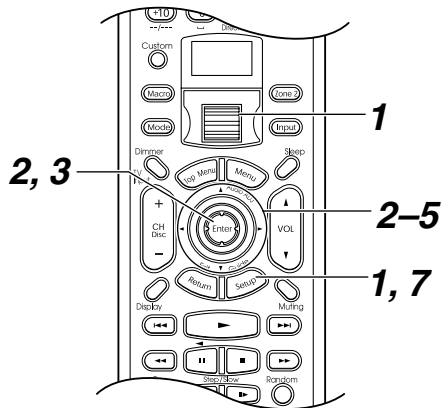
This section explains how to specify the distance between the listening position and each individual speaker so that the sound from each speaker arrives at the listener's ears at the same time.



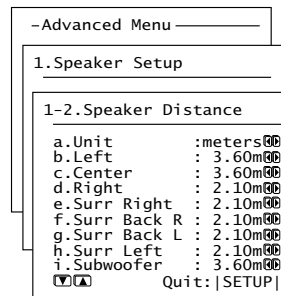

1 	<p>Press the scroll wheel, and then press the [Setup] button. The main menu appears onscreen.</p>
2 	<p>Use the Up/Down [▲]/[▼] buttons to select "1. Speaker Setup," and then press the [Enter] button. The Speaker Setup menu appears.</p>
3 	<p>Use the Up/Down [▲]/[▼] buttons to select "2. Speaker Distance," and then press the [Enter] button.</p>

The Speaker Distance menu appears.

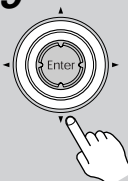

Note:
Speakers that you set to No or None on the Speaker Configuration page (page 41) cannot be selected on this page.

4 	<p>Use the Up/Down [▲]/[▼] buttons to select "a. Unit," and then use the Left/Right [◀]/[▶] buttons to select:</p> <p>feet: Select if you want to enter distances in feet. Can be set from 1 to 30 feet in 0.5-foot steps.</p> <p>meters: Select if you want to enter distances in meters. Can be set from 0.3 to 9 meters in 0.15-meter steps.</p>
5 	<p>Use the Up/Down [▲]/[▼] buttons to select "b. Left," and then use the Left/Right [◀]/[▶] buttons to specify the distance. Specify the distance from the front left speaker to your listening position.</p>
6	<p>Repeat step 5 for all of your speakers.</p>
7 	<p>Press the [Setup] button. The setup menu closes.</p>

Notes:

- If the distance between the furthest and nearest speakers is greater than 20 feet (6 meters), corrected values suitable for home theater use will be set automatically.
- This procedure can also be performed by using the DTR-8.4's [Setup] button, [▲]/[▼]/[◀]/[▶] buttons, and [Enter] button.

Basic Setup—Continued

Speaker Level Calibration

This section explains how to adjust the level of each speaker individually using the built-in test tone so that the volume of each speaker is the same at the listening position.

Notes:

- The speakers cannot be calibrated while the output of the DTR-8.4 is muted, while a pair of headphones is connected, or when using the multichannel inputs.
- **Since the DTR-8.4 supports THX, the test tone is output at the standard level of 0 dB (absolute volume setting 82). If you normally listen at volume settings below this, be careful because the test tone will be much louder.**

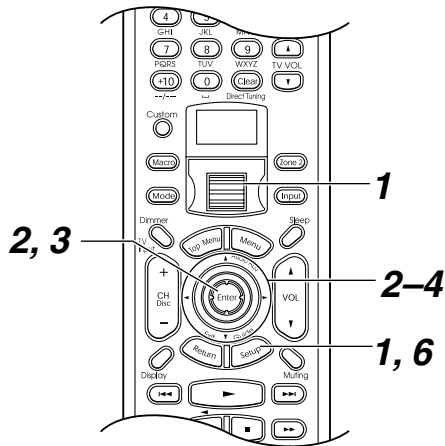

<p>1</p>	<p>Press the scroll wheel, and then press the [Setup] button. The main menu appears onscreen.</p>
<p>2</p>	<p>Use the Up/Down [▲]/[▼] buttons to select “1. Speaker Setup,” and then press the [Enter] button. The Speaker Setup menu appears.</p>

<p>3</p>	<p>Use the Up/Down [▲]/[▼] buttons to select “3. Level Calibration,” and then press the [Enter] button. The Level Calibration menu appears and the pink noise test tone is output by the front left speaker.</p>
-----------------	---

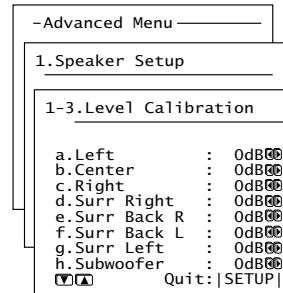

Note:

Speakers that you set to No or None on the Speaker Configuration page (page 41) cannot be selected on this page.

<p>4</p>	<p>Use the Left/Right [◀]/[▶] buttons to adjust the speaker volume, and use the Up/Down [▲]/[▼] buttons to select the other speakers. The volume can be adjusted from -12 to +12 dB in 1 dB steps (-15 to +12 dB for the subwoofer).</p>
-----------------	---

<p>5</p>	<p>Repeat step 4 until the volume of the test tone coming from each speaker is the same.</p>
-----------------	---

<p>6</p>	<p>Press the [Setup] button. The setup menu closes.</p>
-----------------	--

Notes:

- This procedure can also be performed by using the remote controller's [Test Tone] button. First press the [Test Tone] button to output the test tone. Use the [Level-] and [Level+] buttons to adjust the speaker volume, and use the [CH SEL] button to select the other speakers.
- To calibrate the speaker more accurately, use a commercially available sound pressure level (SPL) meter.

Basic Setup—Continued

Input Setup

Digital Setup

This section explains how to assign digital inputs to input sources. You only need to change these assignments if you connect a component to a digital input other than the default assignment listed in the following table. For example, if you connect a DVD player to the DIGITAL IN OPT 2 input, since the default DVD assignment is COAX1, you would need to assign OPT2 to DVD.

Input source	Default digital input
DVD	COAX1 (coaxial 1)
VIDEO 1	COAX2 (coaxial 2)
VIDEO 2	COAX3 (coaxial 3)
VIDEO 3	OPT3 (optical 3)
VIDEO 4	OPT4 (optical 4)
TAPE	OPT2 (optical 2)
PHONO	---- (No assignment)
CD	OPT1 (optical 1)

Note:

If you connect a cassette recorder to the TAPE IN/OUT sockets, you should change the TAPE assignment to “----.”

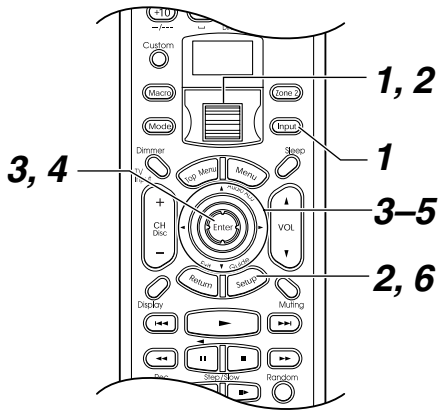

1

Press the [Input] button, and then roll the scroll wheel to select the input source you want to assign.

Note:
There are no assignments for the TUNER, VIDEO 5, and NET AUDIO input sources.

2

Press the scroll wheel, and then press the [Setup] button.

The main menu appears onscreen.

3

Use the Up/Down [▲]/[▼] buttons to select “2. Input Setup,” and then press the [Enter] button.

The Input Setup menu appears.

4

Use the Up/Down [▲]/[▼] buttons to select “1. Digital Setup,” and then press the [Enter] button.

The Digital Setup menu appears.

—Advanced Menu—

2.Input Setup
—Input: DVD

2-1.Digital Setup
—Input: DVD

a.Digital Input : COAX1 **Ⓢ**

b.Digital Format : A11 **Ⓢ**

Quit: [SETUP]

The name of the currently selected input source appears next to “Input,” “DVD” in this case.

5

Use the Up/Down [▲]/[▼] buttons to select “a. Digital Input,” and then use the Left/Right [◀]/[▶] buttons to select a digital input.

6

Press the [Setup] button.

The setup menu closes.

Note:

- This procedure can also be performed by using the input selector buttons, [Setup] button, [▲]/[▼]/[◀]/[▶] buttons, and [Enter] button.

Basic Setup—Continued



Video Setup

This section explains how to assign the composite video/ S-Video inputs to input sources. You only need to change these settings if you connect a video component to a video input other than the default assignment listed in the following table, or if you want to enjoy audio and video from different sources. There are no other reasons to change these assignments.

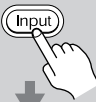

Input source	Analog audio input (fixed)	Composite/ S-Video inputs
DVD	DVD	DVD
VIDEO 1	VIDEO 1	VIDEO1
VIDEO 2	VIDEO 2	VIDEO2
VIDEO 3	VIDEO 3	VIDEO3
VIDEO 4	VIDEO 4	VIDEO4
VIDEO 5	VIDEO 5	VIDEO5
TAPE	TAPE	Last Valid
TUNER	TUNER	Last Valid
PHONO	PHONO	Last Valid
CD	CD	Last Valid
NET AUDIO	NET AUDIO	Last Valid

If, for example, you want to watch the video component connected to the DVD S VIDEO input while listening to the CD input source, change the CD input source assignment from Last Valid to DVD.



As another example, say you connect the audio output of a satellite receiver to the CD input, and its video output to the VIDEO 4 S VIDEO input, since the default video assignment for CD is Last Valid, you'll need to change it to VIDEO 4.

1



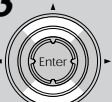

Press the [Input] button, and then roll the scroll wheel to select the input source you want to assign.

2

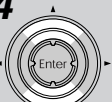

Press the scroll wheel, and then press the [Setup] button.
The main menu appears onscreen.

3



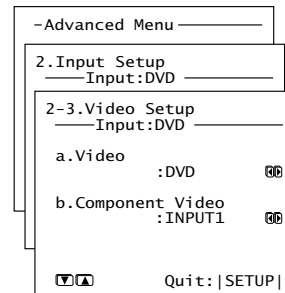

Use the Up/Down [▲]/[▼] buttons to select “2. Input Setup,” and then press the [Enter] button.
The Input Setup menu appears.

4



Use the Up/Down [▲]/[▼] buttons to select “3. Video Setup,” and then press the [Enter] button.
The Video Setup menu appears.

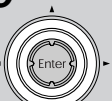

The name of the currently selected input source appears next to “Input,” “DVD” in this case.

5



Use the Up/Down [▲]/[▼] buttons to select “a. Video,” and then use the Left/Right [◀]/[▶] buttons to select a video input.
Select “----” if you don’t want any video to be output while an input source is selected.

6

Press the [Setup] button.
The setup menu closes.

Note:

- If you select Last Valid, the video source remains the same when you select another input source. For example, if you set the VIDEO 1 input source to Last Valid, then select the DVD input source, then select the VIDEO 1 input source, you can watch a DVD while listening to the audio from the component connected to the VIDEO 1 audio inputs.
- This procedure can also be performed by using the input selector buttons, [Setup] button, [▲]/[▼]/[◀]/[▶] buttons, and [Enter] button.

Basic Setup—Continued

Component Video Setup

This section explains how to assign the component video inputs to input sources. You only need to change this setting if you connect a video component to a component video input other than the default assignment listed in the following table, or if you want to output composite video or S-Video sources from the component video output. There are no other reasons to change these assignments.

Input source	Analog audio input (fixed)	Component video inputs
DVD	DVD	INPUT1
VIDEO 1	VIDEO 1	INPUT2
VIDEO 2	VIDEO 2	INPUT2
VIDEO 3	VIDEO 3	INPUT2
VIDEO 4	VIDEO 4	INPUT2
VIDEO 5	VIDEO 5	INPUT2
TAPE	TAPE	Last Valid
TUNER	TUNER	Last Valid
PHONO	PHONO	Last Valid
CD	CD	Last Valid
NET AUDIO	NET AUDIO	Last Valid

1 Press the [Input] button, and then roll the scroll wheel to select the input source you want to assign.

2 Press the scroll wheel, and then press the [Setup] button. The main menu appears onscreen.

3 Use the Up/Down [▲]/[▼] buttons to select “2. Input Setup,” and then press the [Enter] button. The Input Setup menu appears.

4 Use the Up/Down [▲]/[▼] buttons to select “3. Video Setup,” and then press the [Enter] button.

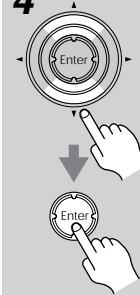

The Video Setup menu appears.

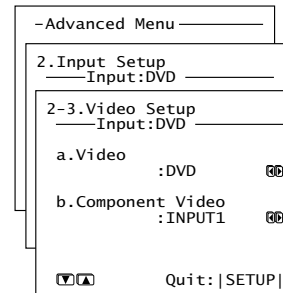

5 Use the Up/Down [▲]/[▼] buttons to select “b. Component Video,” and then use the Left/Right [◀]/[▶] buttons to select:

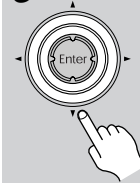

INPUT1: Select if the video component is connected to COMPONENT VIDEO INPUT 1.

INPUT2: Select if the video component is connected to COMPONENT VIDEO INPUT 2.

VIDEO: Select this to output composite and S-Video sources from the COMPONENT VIDEO OUTPUT.

Last Valid: Select this for audio-only components.

None: Select this if you want no video to be output when the input source is selected.

6 Press the [Setup] button. The setup menu closes.



Notes:





- If you select Last Valid, the video source remains the same when you select another input source. For example, if you set the VIDEO 1 input source to Last Valid, then select the DVD input source, you can watch a DVD while listening to the audio from the component connected to the VIDEO 1 audio inputs.
- This procedure can also be performed by using the input selector buttons, [Setup] button, [▲]/[▼]/[◀]/[▶] buttons, and [Enter] button.

Basic Setup—Continued

Remote Setup

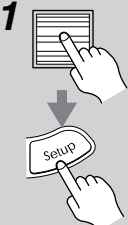
Specifying the Location of an IR Receiver

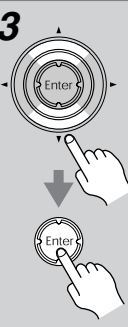
This section explains how to specify the location when using a commercially available IR receiver.

	<p>1 Press the scroll wheel, and then press the [Setup] button. The main menu appears onscreen.</p>
	<p>2 Use the Up/Down [▲]/[▼] buttons to select "0. Hardware Setup," and then press the [Enter] button. The Hardware Setup menu appears.</p>
	<p>3 Use the Up/Down [▲]/[▼] buttons to select "3. Remote Setup," and then press the [Enter] button. The Remote Setup menu appears.</p> <pre data-bbox="406 1220 630 1400"> 0-3.Remote Setup a.Position :Main [00] b.Remote ID :1 [00] [00] [00] Quit: [SETUP] </pre>
	<p>4 Use the Up/Down [▲]/[▼] buttons to select "a. Position," and then use the Left/Right [◀]/[▶] buttons to select:</p> <p>Main: Select if the IR receiver is located in the main room.</p> <p>Zone 2: Select if the IR receiver is located in, and will be used to control Zone 2.</p>
	<p>5 Press the [Setup] button. The setup menu closes.</p>

Note:



- This procedure can also be performed by using the DTR-8.4's [Setup] button, [▲]/[▼]/[◀]/[▶] buttons, and [Enter] button.

Changing the DTR-8.4's Remote Control ID

This section explains how to change the DTR-8.4's remote control ID. You may need to change this if the DTR-8.4's remote controller interferes with other Integra/Onkyo components located in the same room.

Note:

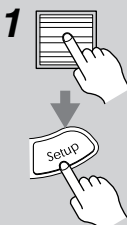
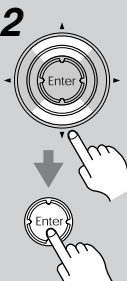
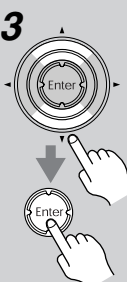
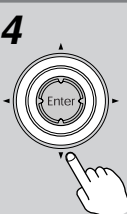
If you change the DTR-8.4's remote control ID, be sure to select the same ID on the remote controller (page 49). The default ID for both the DTR-8.4 and remote controller is 1.

	<p>1 Press the scroll wheel, and then press the [Setup] button. The main menu appears onscreen.</p>
	<p>2 Use the Up/Down [▲]/[▼] buttons to select "0. Hardware Setup," and then press the [Enter] button. The Hardware Setup menu appears.</p>
	<p>3 Use the Up/Down [▲]/[▼] buttons to select "3. Remote Setup," and then press the [Enter] button. The Remote Setup menu appears.</p>
	<p>4 Use the Up/Down [▲]/[▼] buttons to select "b. Remote ID," and then use the Left/Right [◀]/[▶] buttons to select an ID: 1 (default), 2, or 3.</p>
	<p>5 Press the [Setup] button. The setup menu closes.</p>

Note:

- This procedure can also be performed by using the DTR-8.4's [Setup] button, [▲]/[▼]/[◀]/[▶] buttons, and [Enter] button.

Basic Setup—Continued

Changing the Remote Controller's Control ID

This section explains how to change the remote controller's ID. You may need to change this if the DTR-8.4's remote controller interferes with other Integra/Onkyo components located in the same room.

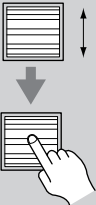
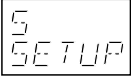
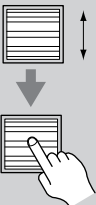
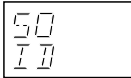
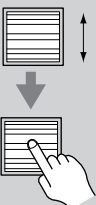

Note:

If you change the remote controller's ID, be sure to select the same ID on the DTR-8.4 (page 48). The default ID for both the DTR-8.4 and remote controller is 1.

<p>1</p>  <p>Custom</p>	<p>Hold down the remote controller's [Custom] button for more than three seconds.</p> <p>The remote controller enters Custom mode.</p>
<p>2</p> 	<p>Roll the scroll wheel to select "SETUP" menu, and then press the scroll wheel.</p> 
<p>3</p> 	<p>Roll the scroll wheel to select ID menu, and then press the scroll wheel.</p> 
<p>4</p> 	<p>Roll the scroll wheel to select an ID—1 (default), 2, or 3—and then press the scroll wheel.</p> <p>Select the same ID as that set on the DTR-8.4.</p>

Specifying the TV System (Australian model only)

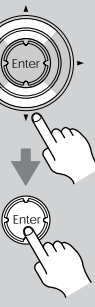
This section explains how to specify the TV system used in your area. (This setting is not available on the American model.)

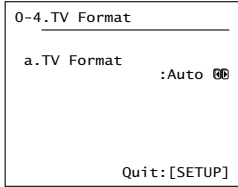
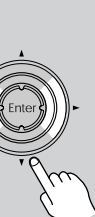
<p>1</p> 	<p>Press the scroll wheel, and then press the [Setup] button.</p> <p>The main menu appears onscreen.</p>
<p>2</p> 	<p>Use the Up/Down [▲]/[▼] buttons to select "0. Hardware Setup," and then press the [Enter] button.</p> <p>The Hardware Setup menu appears.</p>
<p>3</p> 	<p>Use the Up/Down [▲]/[▼] buttons to select "4. TV Format," and then press the [Enter] button.</p> <p>The TV Format menu appears.</p> 
<p>4</p> 	<p>Use the Left/Right [◀]/[▶] buttons to select:</p> <ul style="list-style-type: none"> Auto: The DTR-8.4 automatically detects the TV system. PAL: Select if the TV system in your area is PAL. NTSC: Select if the TV system in your area is NTSC.

Basic Setup—Continued

5



Press the [Setup] button.

The setup menu closes.

Note:

- This procedure can also be performed by using the DTR-8.4's [Setup] button, [▲]/[▼]/[◀]/[▶] buttons, and [Enter] button.

Changing the Input Source Display for Use with a MiniDisc Recorder

If you connect an **RI**-compatible Integra/Onkyo MiniDisc recorder to the DTR-8.4's TAPE IN/OUT sockets, so that **RI** functions such as Auto Power On/Off work properly, you must change the input source display.

This setting can only be changed on the DTR-8.4.

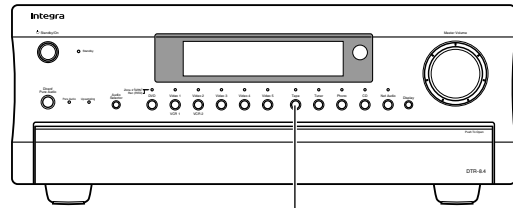

1, 2

1



Press the [Tape] input selector button so that "TAPE" appears on the display.



2



Press and hold down the [Tape] input selector button until "MD" appears on the display (about 3 seconds).



Note:

- To return to the original setting, while "MD" is being displayed, press and hold down the [Tape] input selector button until "TAPE" appears on the display (about 3 seconds).

Basic Operation

Selecting the Source AV Component

This section explains how to select the AV component that you want to listen to or watch.

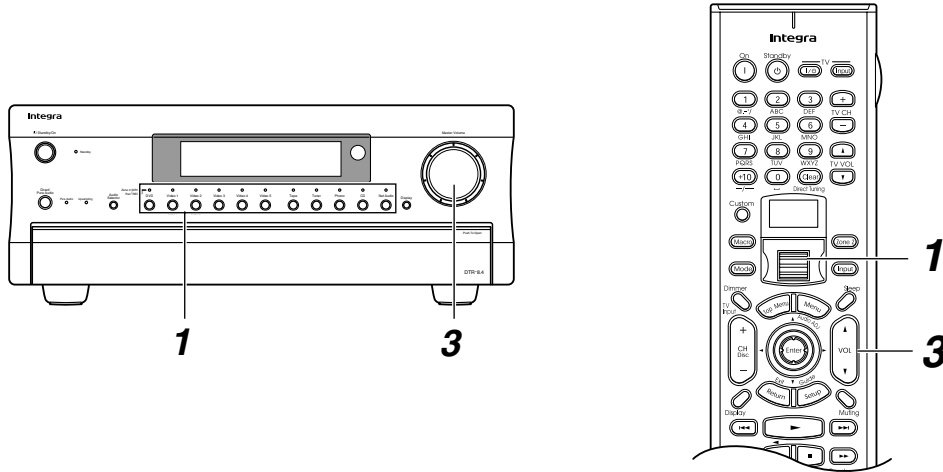

<p>1</p> <p>DTR-8.4</p> <p>DVD Video 1 Video 2 Video 3 Video 4 Video 5 Tape Tuner Phono CD Net Audio</p> <p>or</p> <p>Remote controller</p>	<p>Use the input selector buttons to select the AV component.</p> <p>On the remote controller, roll the scroll wheel to select the input source and remote controller mode.</p> <p>Note: If neither the [Input] nor [Mode] button is illuminated, the input source and remote controller mode are selected simultaneously. If either button is illuminated, press that button first.</p>
<p>2</p>	<p>Start playback on the selected AV component.</p> <p>When you select DVD or another video source component, on your TV you'll need to select the video input to which the DTR-8.4 is connected. On some DVD players, you might need to turn on the digital output.</p>
<p>3</p> <p>DTR-8.4 Master Volume</p> <p>or</p> <p>Remote controller VOL</p>	<p>To adjust the volume, use the MASTER VOLUME control, or the remote controller's [VOL] button.</p> <p>The volume can be set from 0 to 100.</p> <p>The DTR-8.4 is designed for home theater enjoyment. It has a wide volume range, allowing precise adjustment.</p>

Basic Operation—Continued

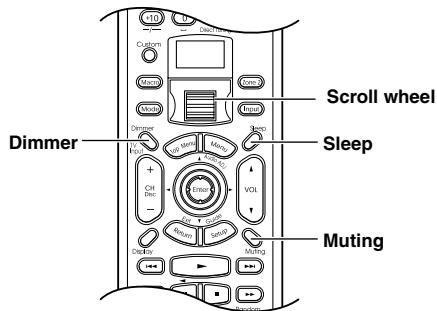

Muting the DTR-8.4 (remote controller only)

With this function you can temporarily mute the output of the DTR-8.4.

Press the scroll wheel, and then press the remote controller's [Muting] button.

The output is muted and the MUTING indicator flashes on the display.

To unmute the DTR-8.4, press the remote controller's [Muting] button again.

Note:

- The Mute function is cancelled when the volume is adjusted or the DTR-8.4 is set to Standby.

Using the Sleep Timer (remote controller only)

With the sleep timer you can set the DTR-8.4 so that it automatically turns off after a specified period.

Press the scroll wheel, and then press the [Sleep] button repeatedly to select the required sleep time.

You can set the sleep time from 90 to 10 minutes in 10 minute steps.

The SLEEP indicator appears on the display when the sleep timer has been set. The specified sleep time appears on the display, then the previous display reappears.

To check the remaining sleep time, press the [Sleep] button. Note that if you press the [Sleep] button while the sleep time is being displayed, you'll shorten the sleep time by 10 minutes.

To cancel the sleep timer, press the [Sleep] button repeatedly until the SLEEP indicator disappears.

Note:

- Any component in Zone 2 connected to the DTR-8.4's 12V TRIGGER OUT will also turn off when the specified sleep time expires.

Setting the Display Brightness

You can adjust the brightness of the DTR-8.4's display as follows.

Press the scroll wheel, and then press the [Dimmer] button to select: dim, dimmer, or normal brightness.

Note:

- This procedure can also be performed by using the DTR-8.4's [Dimmer] button.

Using Headphones

You can connect a pair of stereo headphones (1/4-inch phone plug) to the DTR-8.4's PHONES jack for private listening.

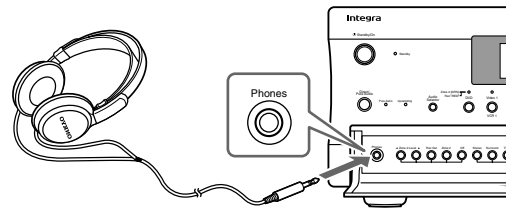



Notes:

- Turn down the volume before connecting your headphones.
- While a pair of headphones is connected to the PHONES jack, no sound is output by the speakers. (Any speakers in Zone 2 continue working.)
- When a pair of headphones is connected, the listening mode is set to Stereo, unless it's already set to Mono, Stereo, Direct, or Pure Audio. When you disconnect the headphones, the previous listening mode is resumed.
- Only the Stereo, Direct, Pure Audio, and Mono listening modes can be used with headphones. (Available listening modes also depends on the currently selected input source.)
- When you use the multichannel inputs, only the front left and right channels can be heard in the headphones.

Basic Operation—Continued

Setting the Input Signal Format

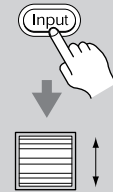
With this function you can set the signal format (analog, digital, or multichannel) that you want to use with AV components that are connected to a digital input, analog input, and the multichannel input. This can be set individually for each input source.



<p>1</p> 	<p>Press the [Input] button, and then roll the scroll wheel to select the input source you want to set.</p>
<p>2</p> 	<p>Press the scroll wheel, and then press the [Audio SEL] button repeatedly to select “Auto,” “Multich,” or “Analog.”</p> <p>Auto: The assigned digital input has priority over the analog input. If no digital signal is present, the analog input is used.</p> <p>Multich: The multichannel input is used.</p> <p>Analog: The analog input is used even if the input source is connected digitally.</p>



Note:

- This procedure can also be performed by using the DTR-8.4's input selector buttons and [Audio Selector] button.

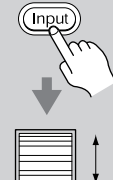
Fixing the Digital Input Format

With this function you can set the digital inputs to accept only DTS, PCM, or both formats. This can be set individually for each input source.

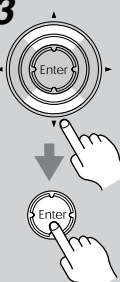
<p>1</p> 	<p>Press the [Input] button, and then roll the scroll wheel to select the input source you want to set.</p>
<p>2</p> 	<p>Press the scroll wheel, and then press the [Setup] button. The main menu appears onscreen.</p>

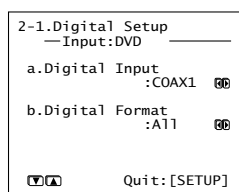
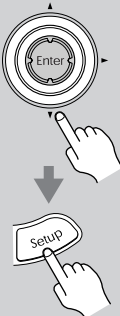
<p>3</p> 	<p>Use the Up/Down [▲]/[▼] buttons to select “2. Input Setup,” and then press the [Enter] button. The Input Setup menu appears.</p>
<p>4</p> 	<p>Use the Up/Down [▲]/[▼] buttons to select “1. Digital Setup,” and then press the [Enter] button. The Digital Setup menu appears.</p> 
<p>5</p> 	<p>Use the Up/Down [▲]/[▼] buttons to select “b. Digital Format,” use the Left/Right [◀]/[▶] buttons to select a format, and then press the [Setup] button.</p> <p>All: PCM, Dolby Digital, and DTS formats are accepted. If no digital signal is present, the analog input is used.</p> <p>DTS: Select this option if playing a DTS CD with the All option produces noise while the DTR-8.4 is identifying the DTS format or when using fast forward or fast reverse. If the input signal is anything other than DTS, nothing is output.</p> <p>PCM: Select this option if playing a CD or other PCM source with the All option causes the tops of tracks to be clipped. If the input signal is anything other than PCM, nothing is output.</p>

Notes:

- Select All or DTS when playing a CD or LD with DTS. If you select PCM, only noise will be heard.
- This procedure can also be performed by using the DTR-8.4's input selector buttons, [Setup] button, [▲]/[▼]/[◀]/[▶] buttons, and [Enter] button.

Basic Operation—Continued

Using the Tuner

With the built-in tuner you can enjoy AM and FM radio stations. You can store your favorite radio stations as presets for quick selection.

Tuning into Radio Stations

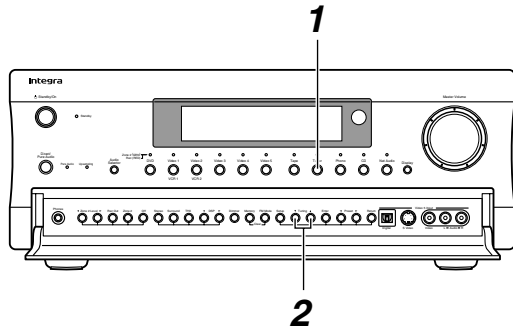

1 Tuner 	Use the [Tuner] input selector button to select either AM or FM.
2 Tuning 	<p>Use the DTR-8.4's Tuning Up/Down [▲]/[▼] buttons to tune into a station.</p> <p>The following illustration shows the tuner-related indicators on the display.</p> <div style="text-align: center;"> <p>TUNED indicator AUTO indicator</p> <p>Band Frequency FM STEREO indicator</p> </div> <p>To locate an FM station automatically, press and hold the Tuning Up or Down [▲]/[▼] button for more than 1/2 a second. The DTR-8.4 scans the FM band up or down, depending on which button you pressed, stopping when a stereo FM station is found.</p>

Notes:

- The tuner frequency changes in 0.1 MHz steps for FM and 10 kHz steps for AM (0.05 MHz and 9 kHz respectively on some models).

■ Listening to Stereo FM Radio Stations

When the DTR-8.4 is properly tuned to a radio station, the “▶ TUNED ◀” indicators appear on the display. When the DTR-8.4 is properly tuned to a stereo FM radio station, the “FM STEREO” indicator appears as well.

If the signal from a stereo FM station is weak, it may be impossible to achieve good reception. If this happens, press the DTR-8.4's [FM Mode] button to listen to the station in mono (the “AUTO” and “FM STEREO” indicators go off).

■ Specifying Radio Stations by Frequency

To select a radio station by entering its frequency, press the remote controller's [Direct Tuning] button, and then use the number buttons to enter the frequency.

Presetting Radio Stations

You can store up to 40 AM and FM radio stations as presets.

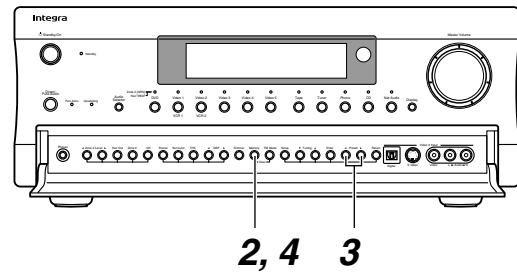



1	Tune into a radio station as explained previously.
2 Memory 	<p>Press the DTR-8.4's [Memory] button.</p> <p>The preset number flashes.</p> <div style="text-align: center;"> </div>
3 Preset 	<p>Use the PRESET [◀]/[▶] buttons to select a preset from 1 to 40.</p>
4 Memory 	<p>Press the [Memory] button to store the preset.</p> <p>The preset number stops flashing. You can name your presets for easy identification (see page 73).</p>

Basic Operation—Continued

Selecting Presets

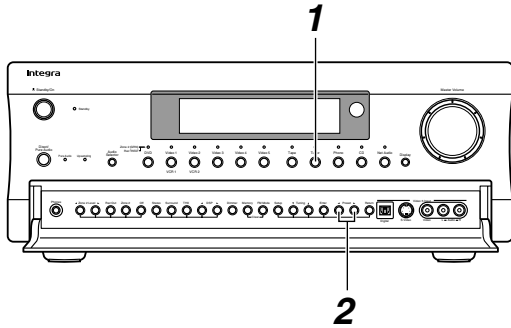
You can select previously stored presets as follows.



1	<p>Tuner</p>  <p>Press the [Tuner] input selector button.</p> <p>On the remote controller, press the [Input] button, and then use the scroll wheel to select TUNER (press the scroll wheel to select FM or AM).</p>
2	<p>Preset</p>  <p>Use the Preset [◀]/[▶] buttons to select the presets.</p> <p>On the remote controller, use the [CH/Disc] button to select the presets.</p>

■ Selecting Presets by Number

To select a preset by number, use the remote controller's number buttons. For example, to select preset #7, press [7]. To select preset #12, press [1] then [2].

Deleting Presets

This section explains how to delete presets.

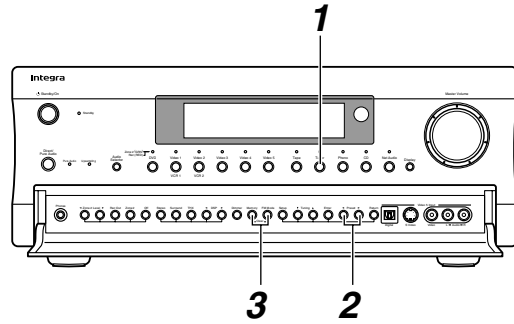

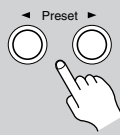
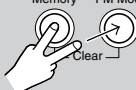
1	<p>Tuner</p>  <p>Press the [Tuner] input selector button.</p>
2	<p>Preset</p>  <p>Use the Preset [◀]/[▶] buttons to select the preset that you want to delete.</p>
3	<p>Memory FM Mode</p>  <p>While holding down the [Memory] button, press the [FM Mode] button.</p> <p>The selected preset is deleted.</p>

Basic Operation—Continued

Listening Modes

About the Listening Modes

With its built-in surround-sound decoders and DSP programs, the DTR-8.4 can transform your home listening room into a movie theater or concert hall.

To get the most from surround sound, it's important that you install and configure your speakers correctly. See "Connecting Your Speakers" on page 23 and "Speaker Settings" on page 40 for information.

The DTR-8.4's surround indicators show which speakers are active in each listening mode.

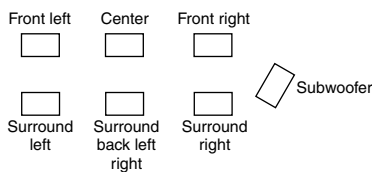

Direct

The selected input source is output by the front left and right speakers only, with minimal processing for a pure sound.

Pure Audio

As an extension of Direct mode, this mode turns off the display, turns off the power to the video circuitry, and minimizes any other possible noise sources, providing a high fidelity sound that's true to the original. (Since the power to the video circuitry is turned off, no video signals will be output.)

Stereo

The selected input source is processed as a stereo signal and output by the front left and right speakers and the subwoofer.

Mono

Use this mode when watching an old movie with a mono soundtrack or to select multilingual soundtracks recorded in the left and right channel of some movies. It can also be used when playing a DVD or other source with multiplexed audio, such as a karaoke DVD.

T-D (Theater-Dimensional)

With this mode you can enjoy a virtual 5.1 surround sound even with only two or three speakers. This works by controlling how sounds reach the listener's left and right ears. Good results may not be possible if there's too much reverb, so we recommend that you use this mode in an environment with little or no natural reverb.

Dolby Pro Logic II Movie

Use this mode with DVDs and videos that bear the Dolby Surround logo or TV programs that feature Dolby Surround. You can also use this mode with stereo movies or TV programs and the DTR-8.4 will create a 5.1 surround mix from the 2-channel stereo.

Dolby Pro Logic II Music

Use this mode to add 5.1 surround to stereo sources such as music CDs and DVDs.

Dolby Digital

With this format you can experience the same superb sound that you get at a movie theater or concert hall. Use this mode with DVDs that bear the Dolby Digital logo.



Dolby Digital EX

With an added surround-back channel, this 6.1 channel format offers a heightened sense of space, for added realism with moving sounds, such as those that rotate 360 degrees or pass overhead. Dolby Digital EX material can also be played on conventional 5.1 channel systems, in which case the surround-back channel audio is divided between the surround left and right channels. Use this mode with DVDs that have a 5.1-channel soundtrack and bear the Dolby Digital logo.



DTS

This digital surround format offers a surround sound experience with exceptional fidelity. It uses compressed digital audio data, with six completely separate channels (5.1), and the ability to handle large amounts of audio data while remaining faithful to the original. DTS provides very high-quality sound. You'll need a DTS compatible DVD player in order to enjoy DTS material. Use this mode with DVDs, LDs, or CDs that bear the DTS logo.



DTS-ES Discrete

This is DTS with an added surround back channel for 6.1 surround sound. Use it with program material recorded in DTS 6.1 format. With the additional surround back channel, this format offers 6.1 fully independent digital channels, providing a realistic sense of movement and space. Use it with program material recorded in DTS 6.1, such as CDs, DVDs, or LDs that bear the DTS-ES logo.



DTS-ES Matrix

This is DTS with an added surround back channel for 6.1 surround sound. Use it to provide 6.1 channel surround playback with program material recorded in DTS 5.1 format. Since DTS 5.1 program material contains surround back channel information, all channels can be reconstructed for 6.1 surround playback. Use this mode with CDs, DVDs, or LDs that bear the DTS-ES or DTS logo.



Basic Operation—Continued

DTS Neo:6

This mode provides 6.1 channel playback from 2-channel sources. It offers six full-bandwidth channels with excellent separation. There are two modes of operation: Cinema mode, which is suited to movies, and Music mode, which is for listening to music.

Cinema mode simulates the realistic sense of movement that you get with 6.1-channel surround sound sources. Use this mode with videos, DVDs, and TV programs that feature stereo sound.

Music mode uses the surround channels to simulate a natural sound field that cannot be produced with conventional stereo. Use this mode with stereo source material such as music CDs.

THX Cinema or

THX Ltd, founded by George Lucas, develops quality assurance programs for ensuring that movies are reproduced in movie theaters and home theaters just as the director intended. THX technology is used to eliminate spatial errors that can occur when a movie soundtrack is adapted for use in smaller home theaters, ensuring faithful reproduction.

This mode is ideal for watching a movie with a soundtrack recorded and edited especially for playback in the spaciousness of a typical movie theater.

THX Surround EX

This format was jointly developed by Dolby Laboratories and THX Ltd. especially for home theater use. It's based on Dolby Digital EX technology. It adds an extra surround channel to the existing front left, front right, center, surround left, surround right, and LFE (subwoofer) channels, making a total of 7.1 channels. (For best results with DVDs that feature THX Surround EX, use a THX-certified THX speaker system.)

DSP Modes

Orchestra or

Suitable for classical or operatic music. The center speaker is turned off and the surround channels are emphasized in order to widen the stereo image. In addition, it simulates the natural reverberation of a large hall.

Unplugged

Suitable for acoustic instrument sounds, vocals, and jazz music. By emphasizing the front stereo image, it simulates the stage-front experience.

Studio-Mix

Suitable for rock and pop music. Listening to music in this mode creates a lively sound field with a powerful acoustic image, like being at a club or rock concert.

TV Logic

Adds realistic acoustics to TV programs produced in a TV studio. In addition, it adds surround effects to the entire sound and adds clarity to voices.

Enhance

This mode is ideal for enjoying music programs or TV sports programs. It provides a natural surround sound with movement in the surround back speakers, creating a sound with a live feeling to it.

Mono Movie

This mode is suitable for use with old movies and other mono sound sources. The center speaker outputs the sound as it is, while reverb is applied to the sound output by the other speakers, giving presence to even mono material.

All Ch Stereo

Ideal for background music. The front, surround, and surround back channels create a stereo image that fills the entire listening area.

Basic Operation—Continued

The following table shows which listening modes can be used with which input signal formats.

Input signal format	Analog, PCM	96 kHz PCM	DTS ¹		Dolby Digital			
			5.1ch	6.1ch	x/2.x (e.g., 5.1)	2/0 (stereo)	1/0 (mono)	Other
Source	CD, TV, LD, VHS, MD, vinyl, radio, cassette, cable, satellite, etc.	96 kHz/24 bit DVD, etc.	DVD, LD, CD, etc.		DVD, digital cable/satellite, etc.			
Listening mode								
Direct	✓	✓						
Pure Audio	✓	✓						
Stereo	✓	✓	✓	✓	✓	✓		✓
Mono	✓					✓	✓	
Theater-Dimensional	✓		✓	✓	✓	✓		✓
Dolby Pro Logic II Movie	✓	✓				✓		
Dolby Pro Logic II Music	✓	✓				✓		
Dolby Digital					✓			✓
Dolby Digital EX					✓			
DTS, DTS 96/24			✓	✓				
DTS-ES Discrete				✓				
DTS-ES Matrix/DTS+Neo:6			✓					
DTS Neo:6 Cinema	✓					✓		
DTS Neo:6 Music	✓					✓		
THX Cinema	✓		✓	✓	✓	✓		✓
THX Surround EX					✓			
Orchestra	✓		✓	✓	✓	✓		✓
Unplugged	✓		✓	✓	✓	✓		✓
Studio-Mix	✓		✓	✓	✓	✓		✓
TV Logic	✓		✓	✓	✓	✓		✓
Enhance	✓		✓	✓	✓	✓		✓
Mono Movie	✓					✓	✓	
All Ch Stereo	✓					✓		

1. When playing DTS 96 kHz/24-bit program material, if the listening mode is Stereo or DTS, it's processed at 96 kHz. If any other listening mode is selected, it's processed at 48 kHz.

Notes:

- Depending on the number of speakers that you connect, and the format of the input signal, you may not be able to select all of the above listening modes.
- If you don't connect any surround back speakers, or you connect speakers in Zone 2, some listening modes will not be available.

Basic Operation—Continued

Selecting Listening Modes

This section explains how to select the listening modes.

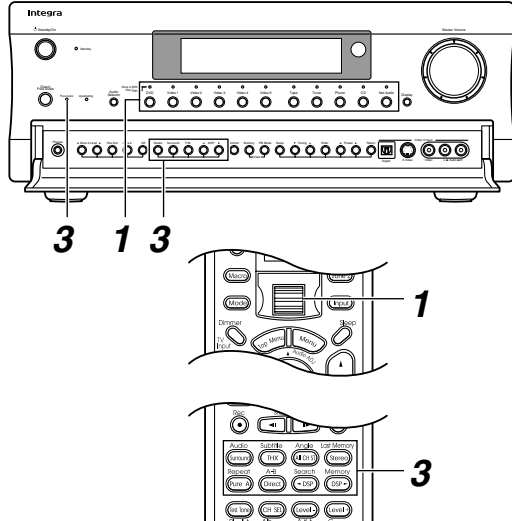

1

DTR-8.4

Use the input selector buttons to select the AV component.

On the remote controller, roll the scroll wheel to select the input source and remote controller mode.

Note:
If neither the [Input] nor [Mode] button is illuminated, the input source and remote controller mode are selected simultaneously. If either button is illuminated, press the illuminated button first.

or

Remote controller

2

Start playback on the selected AV component.

3

DTR-8.4

On the DTR-8.4, use the [Direct/Pure Audio], [Stereo], [Surround], [THX], or DSP [◀]/[▶] buttons to select a listening mode.

On the remote controller, press the scroll wheel, and then use the [Surround], [THX], [All CH ST], [Stereo], [Pure A], [Direct], or DSP [◀]/[▶] buttons to select a listening mode.

Notes:

- You cannot select any listening modes while the Multich input source is selected.
- Depending on the number of speakers that you connect, and the format of the input signal, you may not be able to select all of the listening modes.

■ **[Pure A] button (remote controller)**

This button selects the Pure Audio listening mode.

■ **[Direct] button (remote controller)**

This button selects the Direct listening mode.

■ **[Direct/Pure Audio] button (DTR-8.4)**

This button selects the Direct and Pure Audio listening modes. The PURE AUDIO indicator lights up while the Pure Audio listening mode is selected.

■ **[Stereo] button**

This button selects the Stereo listening mode.

■ **[Surround] button**

This button selects the following listening modes for use with 2-channel analog input sources: Dolby Pro Logic II Movie, Dolby Pro Logic II Music, DTS Neo:6 Cinema, and DTS Neo:6 Music.

If the current input source is digital, you can select Dolby Digital, Dolby Digital EX, DTS, DTS-ES, or DTS Neo:6 with this button. (see “Using the Digital Surround Modes” on page 60).

When a multichannel input source is selected, “Tone On” appears on the display, and you can adjust the bass and treble (see page 68).

■ **[THX] button**

This button selects the THX listening modes. With 2-channel input sources, THX can be applied to Dolby Pro Logic II Movie or DTS Neo:6 Cinema.

The THX listening modes can be selected if the current input source is either analog or digital. If it’s digital, you can use this button to apply THX to DTS or DTS-ES (see “Using the Digital Surround Modes” on page 60).

■ **DSP [◀]/[▶] buttons**

These buttons are used to select Onkyo’s own DSP listening modes—Orchestra, Unplugged, Studio Mix, etc., and Mono or Theater-Dimensional.

■ **[All CH ST] button (remote controller)**

This button selects the All Ch Stereo listening mode.

Basic Operation—Continued

Using the Digital Surround Modes

This section explains functions that can be used when listening to Dolby Digital, and DTS formats.

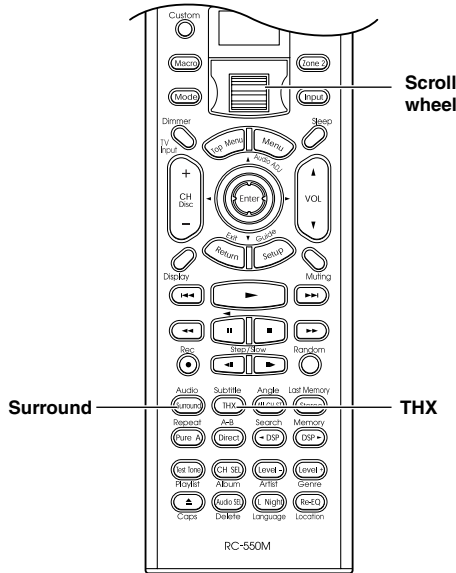

Dolby Digital/Dolby Digital EX

If you are using surround back speakers, you can choose whether to use 6.1 channels or 5.1 channels to playback Dolby Digital material. However, if the surround channel information is mono, or there is no audio in the surround channel, 5.1 channels will be used regardless.

While listening to a Dolby Digital source, press the scroll wheel, and then use the [Surround] button to select: On, Off, or Auto.

- On:** The Dolby Digital EX listening mode (6.1 channels) is used regardless of whether the source signal contains a Dolby Digital EX flag.
- Off:** The Dolby Digital listening mode (5.1 channels) is used even if a Dolby Digital EX flag is present.
- Auto:** If the source signal contains a Dolby Digital EX flag, the Dolby Digital EX listening mode (6.1 channels) is used. If there is no Dolby Digital EX flag, the Dolby Digital listening mode (5.1 channels) is used.

DTS/DTS-ES Discrete/DTS-ES Matrix

If you are using surround back speakers, you can choose whether to use 6.1 channels or 5.1 channels to playback DTS material.

While listening to a DTS source, press the scroll wheel, and then use the [Surround] button to select: Auto, On, or Off.

- Auto:** If the source signal contains a DTS-ES flag, the DTS-ES Discrete or DTS-ES Matrix listening mode is selected automatically. If not, the DTS listening mode (5.1 channels) is used.
- On:** If the source signal contains a DTS-ES flag, the DTS-ES Discrete or DTS-ES Matrix listening mode is selected automatically. If not, DTS+Neo:6 (6.1 channels) is used.
- Off:** The DTS listening mode (5.1 channels) is used for all DTS sources, even if a DTS-ES flag is present.

THX Surround EX (Dolby Digital)

If you are using surround back speakers, you can choose whether to playback a Dolby Digital source with THX Surround EX.

While listening to a THX Surround EX source, press the scroll wheel, and then use the [THX] button to select: On, Off, or Auto.

- On:** The THX Surround EX listening mode is used regardless of whether the source signal contains an EX flag.
- Off:** The THX Cinema listening mode is used even if an EX flag is present.
- Auto:** If the source signal contains an EX flag, the THX Surround EX listening mode is selected automatically. If not, the THX Cinema mode is used.

THX Cinema (DTS/DTS-ES)

You can choose whether to use THX with DTS 5.1 channel playback and DTS-ES 6.1 channel playback.

While listening to a DTS or DTS-ES source, press the scroll wheel, and then use the [THX] button to select: Auto, On, or Off.

- Auto:** If the source signal contains a DTS-ES flag, the DTS-ES Discrete or DTS-ES Matrix listening mode is selected automatically. If not, the DTS listening mode (5.1 channels) is used.
- On:** If the source signal contains a DTS-ES flag, the DTS-ES Discrete or DTS-ES Matrix listening mode is selected automatically. If not, DTS+Neo:6 (6.1 channels) is used.
- Off:** The DTS listening mode (5.1 channels) is used for all DTS sources, even if a DTS-ES flag is present.

Basic Operation—Continued

Display Indicators & Source Info

When the format of a digital input signal is recognized, depending on the format, one of the indicators shown below will appear on the display.

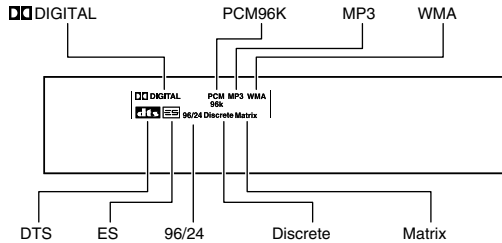

When you select one of the listening modes, one of the indicators shown below will appear on the display.

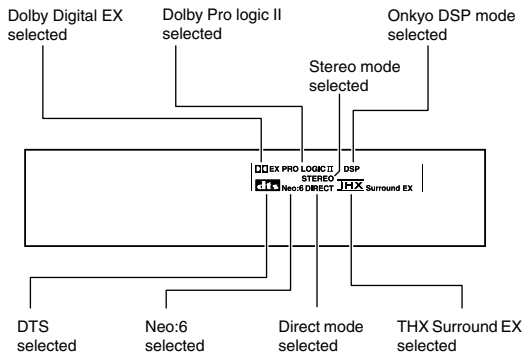

Note:

When playing a Dolby Digital source, the message “Dialog Norm xx” may appear on the display, “xx” being a number. Dialog normalization is a function of Dolby Digital that is used to correct the playback level of soundtracks that have been recorded at an unusually high or low level. It works automatically and no user intervention is required. It appears on the display just to let you know that it’s working. It’s unaffected by the DTR-8.4’s volume control.

Displaying Source Information

You can display various information about the currently selected input source by first pressing the scroll wheel, and then pressing the [Display] button repeatedly.

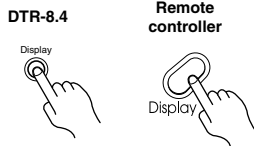

Analog Input Sources

Input source ↔ Input source & listening mode

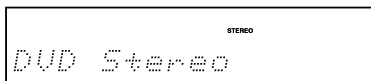

PCM Input Sources

Input source → Sampling rate*¹
 Sampling rate¹ ← Input source & listening mode

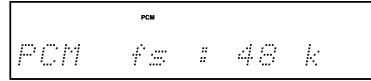

Other Digital Input Sources

Input source → Input signal & surround format*^{1, 2}
 Input signal & surround format*^{1, 2} ← Input source & listening mode

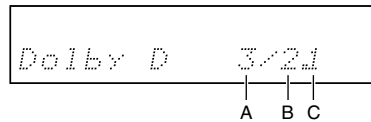

*:1. If the input signal doesn’t contain the information, nothing will be displayed. The sampling rate or surround format is displayed for about three seconds. After that, the previously displayed information reappears.

*:2. Surround Format Display

This section explains the surround format indication (e.g., 3/2.1).

- A:** the number of front channels.
 3: front left, center, and front right.
 2: front left and front right.
 1: one channel.
- B:** the number of surround channels.
 3: surround left, surround right, and surround back.
 2: surround left and surround right.
 1: one channel.
- C:** the presence of an LFE (Low Frequency Effect) channel.
 1: yes.
 Nothing means no.

For example, 3/2.1 indicates the input source has 5.1 channels, consisting of three front channels, two surround channels, and an LFE channel. Likewise, 3/3.1 indicates the input source has 6.1 channels, consisting of three front channels, two surround channels, a surround back channel, and an LFE channel.

AM or FM Input Source

Band, frequency & preset # ↔ Band & listening mode

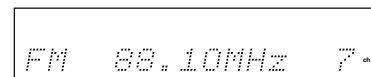

Basic Operation—Continued

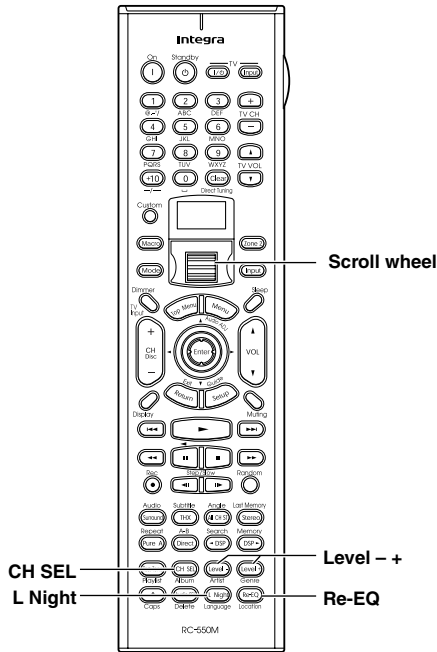

Adjusting the Volume of Individual Speakers

With this function you can adjust the volume of each speaker individually. These adjustments are not saved and the previous settings will be resumed when the DTR-8.4 is set to Standby.

1 Press the scroll wheel, and then use the [CH SEL] button to select each speaker.

Speakers are selected in the following order:

```

          Front left → Center → Front right
          ↑
Subwoofer
          ↑
Surr left ← Surr back left ← Surr back right
          ↓
          Surr right
        
```

2 Use the [Level-] and [Level+] buttons to adjust the volume.

The volume can be adjusted from -12 to +12 dB in 1 dB steps (-15 to +12 dB for the subwoofer).

Note:

- You cannot select speakers that are set to No or None on the Speaker Configuration menu (see page 41).

Using the Re-EQ function

With the Re-EQ function you can correct a soundtrack whose high-frequency content is too harsh, making it more suitable for home theater viewing.

This function can be used with the following listening modes: Mono, Stereo, All Ch St, Dolby Digital, Dolby Digital EX, Dolby Pro Logic II Movie, DTS, DTS-ES, DTS Neo:6 Cinema, THX Cinema, and THX Surround EX.

1 Press the scroll wheel, and then press the [Re-EQ] button. Press the button again to turn off the Re-EQ function.

Notes:

- The Re-EQ function can also be set on the onscreen setup menus (see page 69).
- When the listening mode is THX, the default setting is On. When the DTR-8.4 is set to Standby, it returns to the default setting.
- When the listening mode is not THX, the default setting is Off.

Using the Late Night function (Dolby Digital only)

With the Late Night function you can reduce the dynamic range of Dolby Digital material so that you can still hear quiet parts even when listening at low volume levels—ideal for watching movies late at night when you don't want to disturb anyone.

1 Press the scroll wheel, and then press the [L Night] button repeatedly to select:

Off: Late Night function off.

Low: Small reduction in dynamic range.

High: Large reduction in dynamic range.

Notes:

- The Late Night function can also be set on the onscreen setup menus (see page 69).
- The effect of the Late Night function depends on the Dolby Digital material that you are playing, and with some material there will be little or no effect.
- The Late Night function is turned off when the DTR-8.4 is set to Standby.

Advanced Operation

Using the Multichannel Input

This section explains how to use the multichannel analog input. Connecting the 5.1 or 7.1 analog outputs of your DVD player to the multichannel analog input allows you to enjoy DVD-Audio discs and Super Audio CDs, providing that your DVD player supports those formats. See page 29 for connection details.

Setting the Multichannel Input

Before using the multichannel input, you need to assign it to an input source. By default, it's assigned to the DVD input source, as shown in the following table, so if you connect a DVD player to the multichannel input, no further settings are required.

Note:

- The Net-Tune input source cannot be set to Yes.

Input source	Default setting
DVD	Yes
VIDEO 1	No
VIDEO 2	No
VIDEO 3	No
VIDEO 4	No
VIDEO 5	No
CD	No
PHONO	No
TUNER	No
TAPE	No

1  Press the [Input] button, and then roll the scroll wheel to select the input source you want to set.

2  Press the scroll wheel, and then press the [Setup] button. The main menu appears.

3  Use the Up/Down [\blacktriangle]/[\blacktriangledown] buttons to select "2. Input Setup," and then press the [Enter] button. The Input Setup menu appears.

4  Use the Up/Down [\blacktriangle]/[\blacktriangledown] buttons to select "2. Multichannel Setup," and then press the [Enter] button. The Multichannel Setup menu appears.

```

-Advanced Menu-----
2.Input Setup
  Input: DVD
2-2.Multichannel Setup
  Input: DVD
a.Multichannel :Yes 00
Quit: |SETUP|

```

5  Use the Left/Right [\blacktriangleleft]/[\blacktriangleright] buttons to select:
Yes: Assigned to multichannel analog input.
No: Not assigned to multichannel analog input.

6  Press the [Setup] button. The setup menu closes.

Note:

- This procedure can also be performed by using the DTR-8.4's [Setup] button, [\blacktriangle]/[\blacktriangledown]/[\blacktriangleleft]/[\blacktriangleright] buttons, and [Enter] button.

Advanced Operation—Continued

Selecting the Multichannel Input

This section explains how to select the multichannel analog input for playback.

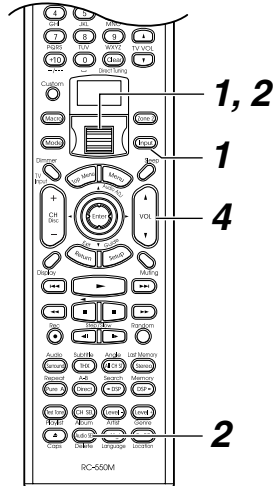

1		<p>Press the [Input] button, and then roll the scroll wheel to select "DVD."</p>
2		<p>Press the scroll wheel, and then press the [Audio SEL] button repeatedly to select "Multich."</p>
3		<p>Start playback on your DVD player.</p>
4		<p>To adjust the volume, use the Master Volume control, or the remote controller's [VOL] button. The volume can be set from 0 to 100.</p>

Notes:

- This procedure can also be performed by using the DTR-8.4's input selector buttons and [Audio Selector] button.
- You can only use the Direct and Pure Audio listening modes with the multichannel input. If another listen-

ing mode is being used when the multichannel input is selected, that listening mode is cancelled.

- Press the [Surround] button to adjust a bass and treble effect ("Tone On" appears on the display).

Adjusting the Volume of Individual Speakers for the Multichannel Input

While using the multichannel input, you can adjust the volume of each speaker individually.

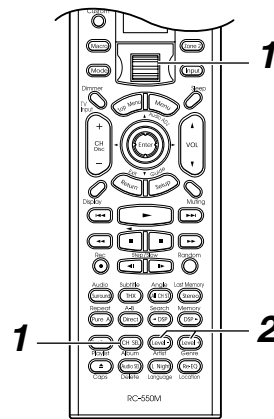

1		<p>Press the scroll wheel, and then use the [CH SEL] button to select each speaker.</p> <p>Speakers are selected in the following order.</p> <pre> Front left → Center → Front right ↑ ↓ Subwoofer Surr right ↑ ↓ Surr left ← Surr back left ← Surr back right </pre>
2		<p>Use the [Level-] and [Level+] buttons to adjust the volume.</p> <p>The volume can be adjusted from -12 to +12 dB in 1 dB steps (-30 to +12 dB for the subwoofer).</p>

Note:

- You cannot select speakers that are set to No or None on the Speaker Configuration menu (see page 41).
- These settings are not the same as the level calibration settings on page 44.
- These settings affect only the multichannel input source and have no effect on other input sources.

Advanced Operation—Continued

Recording

This section explains how to record the current input source, how to record an input source while listening or watching another input source, and how to record from separate audio and video sources.

Unless you have the full consent of the copyright holder, copyright laws prohibit using your recordings for anything other than personal enjoyment!

Notes:

- The surround sound and DSP listening modes cannot be recorded.
- Copy-protected DVDs cannot be recorded.
- You cannot record from the multichannel input.
- Digital audio fed to the DIGITAL IN COAX/OPT inputs is output by the DIGITAL OUT OPT outputs. MP3, WAV, and other files played over Net-Tune are output only by the analog audio outputs.
- Various restrictions apply to digital recording. Refer to the manuals supplied with your digital recording equipment for more details.
- Digital input signals are output by only the digital outputs, and analog input signals are output by only the analog outputs. There is no internal conversion from digital to analog or vice versa.
- DTS signals will be recorded as noise, so don't attempt analog recording of DTS CDs or LDs.



Recording the Current Input Source

You can record the current input source as follows.

1	Use the input selector buttons to select the AV component that you want to record.
2 	Press the [Rec Out] button repeatedly until "Rec Sel: SOURCE" appears on the display. Tip: Press the [Rec Out] button twice to quickly select "SOURCE." The current input source can now be recorded by the recorder connected to the TAPE OUT, VIDEO 1 OUT, or VIDEO 2 OUT outputs.
3	Start recording on the recorder. See your recorder's manual for more information.
4	Start playback on the source AV component. If you select another input source during recording, the newly selected input source will be recorded.

Recording a Separate Input Source

While enjoying one input source, you can record from a separate input source. You could, for example, watch a DVD while recording a CD to tape.

1 	Press the [Rec Out] button.
2 	Within eight seconds, press the input selector button for the input source that you want to record. The name of the input source selected for recording appears on the display. The specified input source can now be recorded by the recorder connected to the TAPE OUT, VIDEO 1 OUT, or VIDEO 2 OUT outputs.
3	Start recording on the recorder. See your recorder's manual for more information.
4	Start playback on the source AV component.

Notes:

- Since the Zone 2 function and the REC OUT outputs use the same circuitry, you cannot record from separate sources and use Zone 2 at the same time.
- To turn off the REC OUT outputs (i.e., TAPE OUT, VIDEO 1 OUT, or VIDEO 2 OUT), press the [Rec Out] button, and then press the [Off] button within eight seconds.

Advanced Operation—Continued

Recording Separate AV Sources

You can record audio and video from separate sources, allowing you to dub audio onto your video recordings. In the following example, audio from the CD player connected to the CD IN input, and video from the camcorder connected to the VIDEO 5 INPUT VIDEO input are recorded to the VCR connected to the VIDEO 1 OUT output.

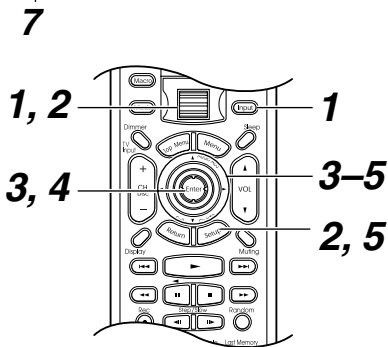
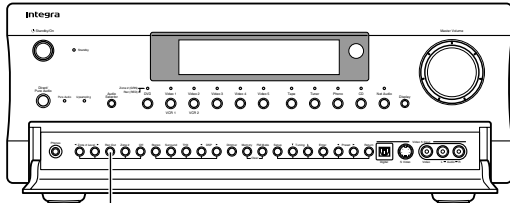

<p>1</p>	<p>Press the [Input] button, and then roll the scroll wheel to select the CD input source.</p>
<p>2</p>	<p>Press the scroll wheel, and then press the [Setup] button. The main menu appears onscreen.</p>
<p>3</p>	<p>Use the Up/Down [▲]/[▼] buttons to select “2. Input Setup,” and then press the [Enter] button. The Input Setup menu appears.</p>

<p>4</p>	<p>Use the Up/Down [▲]/[▼] buttons to select “3. Video Setup,” and then press the [Enter] button. The Video Setup menu appears.</p> <pre> -Advanced Menu----- 2.Input Setup Input: DVD 2-3.Video Setup Input: CD a.Video :Last Valid [OK] b.Component Video :Last Valid [OK] [Left][Right] Quit: [SETUP] </pre>
<p>5</p>	<p>Use the Up/Down [▲]/[▼] buttons to select “a. Video,” and then use the Left/Right [◀]/[▶] buttons to select “VIDEO5.” Press the [Setup] button to close the setup menu.</p>
<p>6</p>	<p>Prepare your CD player and camcorder for playback, and your VCR for recording.</p>
<p>7</p> <p>DTR-8.4 Rec Out</p>	<p>Press the [Rec Out] button repeatedly until “Rec Sel: SOURCE” appears on the display. Audio from the CD player and video from the camcorder can now be recorded by the VCR connected to the VIDEO 1 OUT outputs.</p>
<p>8</p>	<p>Start recording on the VCR and start playback on the camcorder and CD player.</p>

Note:

- For advanced audio dubbing, if you assign the VIDEO 5 INPUT VIDEO input to an additional input source, say, the TAPE IN input, you can dub audio from two sources and use the [CD] and [Tape] input selector buttons to switch between them during recording.

Advanced Setup

Assigning Listening Modes to Input Sources

You can assign a listening mode to each input source so that it's selected automatically each time you select that input source. This is useful when you regularly use, say, the Dolby Digital listening mode with your DVD player.

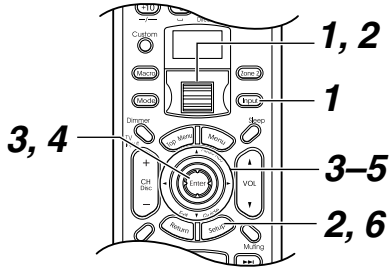

1 **Press the [Input] button, and then roll the scroll wheel to select the input source you want to set.**

2 **Press the scroll wheel, and then press the [Setup] button.**
The main menu appears onscreen. If the Basic menu appears, use the Down [▼] button to select Advanced Menu, and press the [Enter] button to display the Advanced menu.

3 **Use the Up/Down [▲]/[▼] buttons to select "2. Input Setup," and then press the [Enter] button.**
The Input Setup menu appears.

4 **Use the Up/Down [▲]/[▼] buttons to select "6. Listening Mode Preset," and then press the [Enter] button.**
The Listening Mode Preset menu appears.

-Advanced Menu-

2. Input Setup
Input: DVD

2-6. Listening Mode Preset
Input: DVD

a. Analog/PCM : Stereo

b. PCM fs=96k : Stereo

c. Dolby D : Dolby D

d. DTS : DTS

e. D.F. 2ch : PLII

f. D.F. Mono: Mono

Quit: |SETUP|

5 **Use the Up/Down [▲]/[▼] buttons to select the settings, and use the Left/Right [◀]/[▶] buttons to set them.**
The settings are explained below.

6 **Press the [Setup] button.**
The setup menu closes.

■ a. Analog/PCM

With this setting you can specify the listening mode to be used when an analog (CD, TV, LD, VHS, MD, vinyl, radio, cassette, cable, satellite, etc) or PCM digital (CD, DVD, digital cable/satellite, etc) audio signal is played. Only listening modes that can be used with analog or PCM signal formats can be selected.

- The Last Valid option means that the listening mode selected last will be used.

■ b. PCM fs = 96k

With this setting you can specify the listening mode to be used when a PCM 96 kHz digital audio signal is played (DVD, etc).

Only listening modes that can be used with the PCM 96 kHz signal format can be selected.

- The Last Valid option means that the listening mode selected last will be used.

■ c. Dolby D

With this setting you can specify the listening mode to be used when a Dolby Digital format digital audio signal is played (DVD, digital cable/satellite, etc).

Only listening modes that can be used with Dolby Digital can be selected.

- The Last Valid option means that the listening mode selected last will be used.

■ d. DTS

With this setting you can specify the listening mode to be used when a DTS format digital audio signal is played (DVD, LD, CD, etc).

Only listening modes that can be used with DTS can be selected.

- The Last Valid option means that the listening mode selected last will be used.

■ e. D.F. 2ch

With this setting you can specify the listening mode to be used when a 2-channel (2/0) digital audio signal (PCM, Dolby Digital, DTS) is played (DVD, digital cable/satellite, etc).

Only listening modes that can be used with 2-channel digital audio can be selected.

- The Last Valid option means that the listening mode selected last will be used.

Advanced Setup—Continued

■ f. D.F. Mono

With this setting you can specify the listening mode to be used when a mono digital audio signal is played (DVD, etc).

Only listening modes that can be used with mono PCM, Dolby Digital, or DTS can be selected.



- The Last Valid option means that the listening mode selected last will be used.



Notes:

- The b, c, d, e, and f settings are available only when an digital audio input is assigned to the selected input source.
- You can select other listening modes during playback (see page 59), however, the listening mode assigned here will be resumed after the DTR-8.4 has been set to Standby.

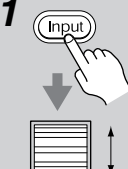
Assigning the A & B 12V Trigger Outputs

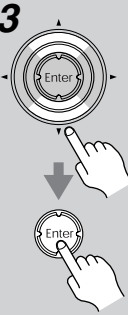
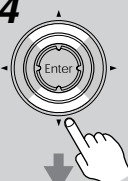

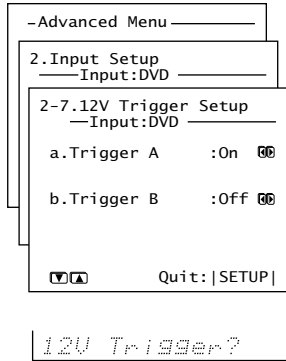
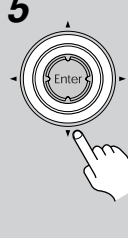
This section explains how to assign input sources to the 12V TRIGGER OUT A and B outputs.

	<p>1 Press the [Input] button, and then roll the scroll wheel to select the input source you want to assign.</p>
	<p>2 Press the scroll wheel, and then press the [Setup] button. The main menu appears onscreen.</p>
	<p>3 Use the Up/Down [▲]/[▼] buttons to select "2. Input Setup," and then press the [Enter] button. The Input Setup menu appears.</p>
	<p>4 Use the Up/Down [▲]/[▼] buttons to select 7. 12V Trigger Setup, and then press the [Enter] button.</p>

	<p>The 12V Trigger Setup menu appears.</p> 
	<p>5 Use the Up/Down [▲]/[▼] buttons to select a. Trigger A or b. Trigger B, and use the Left/Right [◀]/[▶] buttons to select: On: Trigger output active while input source selected. Off: Trigger output not active while input source selected.</p>
	<p>6 Press the [Setup] button. The setup menu closes.</p>

Audio Adjust Functions

This section explains the audio and listening mode settings you can use to tailor the sound as you like.

	<p>1 Press the scroll wheel, and then press the [Setup] button. The main menu appears onscreen.</p>
	<p>2 Use the Up/Down [▲]/[▼] buttons to select "3. Audio Adjust," and then press the [Enter] button. The Audio Adjust menu appears.</p>

Advanced Setup—Continued

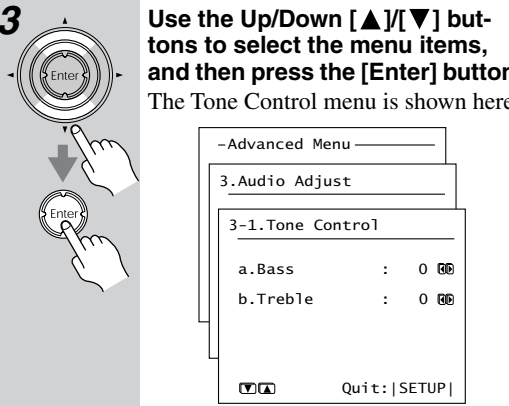
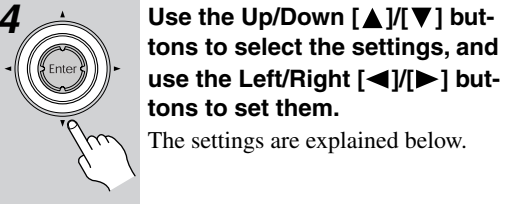
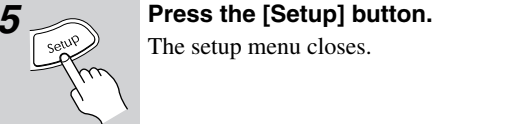
3	 <p>Use the Up/Down [▲]/[▼] buttons to select the menu items, and then press the [Enter] button. The Tone Control menu is shown here.</p>
4	 <p>Use the Up/Down [▲]/[▼] buttons to select the settings, and use the Left/Right [◀]/[▶] buttons to set them. The settings are explained below.</p>
5	 <p>Press the [Setup] button. The setup menu closes.</p>

Note:

- This procedure can also be performed by using the DTR-8.4's [Setup] button, [▲]/[▼]/[◀]/[▶] buttons, and [Enter] button.

3-1. Tone Control

■ a. Bass

You can adjust the bass for the front left, right, and center speakers and subwoofer in 2 dB steps from -12 to +12 dB. The default setting is 0 dB. The bass cannot be adjusted while the Direct, Pure Audio, or THX listening mode is selected.

■ b. Treble

You can adjust the treble for the front left, right, and center speakers in 2 dB steps from -12 to +12 dB. The default setting is 0 dB. The treble cannot be adjusted while the Direct, Pure Audio, or THX listening mode is selected.

3-2. Surround Speakers

■ a. Surround Speakers

If you are using surround back speakers, you can choose which surround speakers to use when playing 5.1 material. This setting can be used with the following listening modes: DTS, DTS96/24, Dolby Digital, Dolby Pro Logic II, THX Cinema (PL II), Mono Movie, Orchestra, Unplugged, Studio-Mix, and TV Logic.

Surround L/R: Use only the surround left and right speakers.

Surround Back: Use only the surround back left and right speakers.

Surr L/R+back: Use the surround left and right and surround back left and right speakers.

3-3. Sound Effect

■ a. Re-EQ

This is the same as the Re-EQ function explained on page 62. This function can be used with the following listening modes: Mono, Stereo, All Ch St, Dolby Digital, Dolby Digital EX, Dolby Pro Logic II Movie, DTS, DTS-ES, and DTS Neo:6 Cinema.

■ b. Upsampling

With the Upsampling function you can double the sampling rate for more detailed playback. Upsampling can be used with the following listening modes: Stereo and Dolby Pro Logic II.

On: Sampling rate doubled. (UPSAMPLING indicator lights up.)

Off: Upsampling function off.

■ c. Double Bass

With the Double Bass function you can boost the bass output by feeding the bass sounds of the front left and right channels to the subwoofer. This function can be used only if the Speaker Config menu Subwoofer setting is set to Yes, and the Front L/R setting is set to Large (see page 41).

On: Double Bass function on (default).

Off: Double Bass function off.

■ d. Late Night

This is the same as the Late Night function explained on page 62. It can be used only when the listening mode is Dolby Digital.

3-4. Delay

■ a. A/V Sync

When using progressive scanning, you may find that the picture and sound are out of sync. With the A/V Sync function you can delay the audio in 0.5 ms steps from 0 to 74.0 ms to get the picture and audio back in sync. The default setting is 0 ms.

Note:

- If a delay time between 24.5 ms and 74 ms is set, and then the Upsampling function is turned on, the delay time will be fixed at 24.0 ms, however, the value shown on the display will not change.
- This function cannot be used with the multichannel input.

■ b. Relative Delay

With Integra/Onkyo's unique Enhanced Spatial Positioning Algorithm you can fine-tune the sound field by delaying the signals to all speakers in 0.5 ms steps from -4.0 ms to +6.0 ms (default is 0 ms). This 10 ms range equates to a physical speaker movement of 10 feet (3 m). Before adjusting this setting, specify the distance between the listening position and each individual speaker (see page 43), and adjust the level of each speaker individually (see page 44).

By increasing the distance between the speakers (i.e., increasing the delay time), the sound field can be broadened, and by reducing the distance (i.e., reducing the delay time), the sound field can be narrowed.

The procedure for changing these settings is provided on page 68.

Advanced Setup—Continued

3-5. LFE Level

■ a. Dolby Digital

With this setting you can adjust the level of the LFE (Low Frequency Effects) channel for Dolby Digital sources in 1 dB steps from -10 dB to 0 dB (default is 0 dB).

If you find that the low-frequency effects are too loud when playing Dolby Digital sources, lower this setting as necessary.

■ b. DTS

With this setting you can adjust the level of the LFE (Low Frequency Effects) channel for DTS sources in 1 dB steps from -10 dB to 0 dB (default is 0 dB).

If you find that the low-frequency effects are too loud when playing DTS sources, lower this setting as necessary.

3-6. Mono

■ a. Academy Filter

Early movies had a mono soundtrack that suffered from audible hiss and a poor high-frequency response due to the quality of the film. To improve matters, the high-frequencies were boosted before being recorded onto film, and then attenuated to their original levels during playback in the movie theater. Some old movies have been transferred to newer distribution media without the high-frequencies being attenuated, creating a harsh sound with pronounced hiss. With the Academy Filter function, which is based on the playback techniques used in those days, you can attenuate the high-frequencies to their original levels and enjoy the movie as it was intended to be heard.

On: Academy Filter on.

Off: Academy Filter off (default).

■ b. Input Channel

With this setting you can specify how 2-channel sources are handled in the Mono listening mode.

AUTO L+R: The front left and right speakers output the same mix of the left and right channels (default).

Left: The front left and right speakers output the sound recorded in the left channel. Use this option with material that has different languages recorded in the left and right channels.

Right: The front left and right speakers output the sound recorded in the right channel. Use this option with material that has different languages recorded in the left and right channels.

3-7. Theater-Dimensional

These settings are used with the Theater-Dimensional listening mode.

■ a. Listening Angle

With this setting you can specify the angle of the front left and right speakers relative to the listening position. Processing for the Theater-Dimensional listening mode is based on this setting. Ideally, the front left and right speakers should be equidistant from the listening position and at an angle close to one of the two available settings.

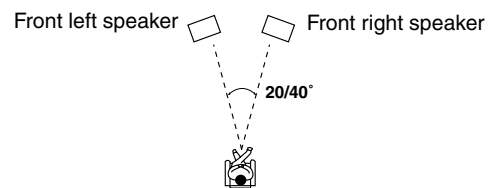

20°: Select if listening angle is 20 degrees.

40°: Select if listening angle is 40 degrees (default).

■ b. Center

With this setting you can specify whether or not you're using a center speaker. If you are, the center channel sound will be output by the center speaker when using the Theater-Dimensional listening mode. This reduces the workload of the front left and right speakers, and creates a more articulate sound space. In this case, the settings for the distance between the listening position and each individual speaker (see page 43), and the level of each speaker (see page 44) are important, so be sure to set them.

On: Select if using a center speaker.

Off: Select if not using a center speaker (default).

■ c. Front Expander

With the Front Expander function you can broaden the width the front stereo image. This can be useful with narrow listening angles of 20 degrees or less.

On: Front Expander function on.

Off: Front Expander function off (default).

■ d. Virtual Surr Level

With this setting you can adjust the level of the virtual surround sound from -3 dB to +3 dB (default is 0 dB). If the clarity is poor, or the effect sounds unnatural, you may be able to improve it by lowering this setting.

■ e. Dialog Enhance

With this function you can improve the clarity of the center channel, which usually contains dialog.

On: Dialog Enhance function on.

Off: Dialog Enhance function off (default).

The procedure for changing these settings is provided on page 68.

Advanced Setup—Continued

3-8. Surround

These settings are for the surround sound modes.

■ a. Surr Mode (Analog/PCM)

This setting determines the default surround format to be used with analog and PCM input signals. The available options are: Pro Logic II Movie (default), Pro Logic II Music, Neo:6 Cinema, and Neo:6 Music.

■ b. Surr Mode (D.F. 2ch)

This setting determines the default surround format that will be used with 2-channel digital signals other than PCM. The available options are: Pro Logic II Movie (default), Pro Logic II Music, Neo:6 Cinema, and Neo:6 Music.

■ c. Dolby D EX (Dolby D)

This is the same as “Dolby Digital/Dolby Digital EX” on page 60. It can be set even while a listening mode other than Dolby is selected.

■ d. DTS-ES

This is the same as “DTS/DTS-ES Discrete/DTS-ES Matrix” on page 60. It can be set even while a listening mode other than DTS is selected.

■ e. Pro Logic II Music Panorama

With this function you can broaden the width of the front stereo image when using the Dolby Pro Logic II Music listening mode.

On: Panorama function on.

Off: Panorama function off (default).

■ f. Pro Logic II Music Dimension

With this setting you can move the sound field forward or backward when using the Dolby Pro Logic II Music listening mode. The default setting is 3. Lower settings move the sound field forward. Higher settings move it backward.

If the stereo image feels too wide, or there's too much surround sound, move the sound field forward to improve the balance. Conversely, if the stereo image feels like it's in mono, or there's not enough surround sound, move it backward.

■ g. Pro Logic II Music Center Width

With this setting you can adjust the width of the sound from the center speaker when using the Dolby Pro Logic II Music listening mode.

If you're using a center speaker, with Dolby Pro Logic II, the center channel sound is output by only the center speaker. (If you're not using a center speaker, the center channel sound will be distributed to the front left and right speakers to create a phantom center). This setting controls the front left, right, and center mix, allowing you to adjust the weight of the center channel sound. It can be adjusted from 0 to 7 (default is 3).

■ h. Neo:6 Music Center Image

The DTS Neo:6 Music listening mode creates 6-channel surround sound from 2-channel (stereo) material. With this setting you can specify by how much the front left and right channel output is attenuated in order to create the center channel. It can be adjusted from 0 to 5 (default is 3).

When set to 0, the front left and right channel output is attenuated by half (–6 dB), giving the impression that the sound is located centrally. This setting works well when the listening position is considerably off center. When set to 5, the front left and right channels are not attenuated, maintaining the original stereo sound balance.

3-9. THX

These settings are for the THX modes.

■ a. Re-EQ (THX)

This setting determines the default on/off setting for the Re-EQ function, which is explained on page 62. This setting is used only when a THX listening mode is selected.

■ b. Decoder (2ch)

This setting determines whether THX Cinema should be applied to the Dolby Pro Logic II Movie or Neo:6 Cinema listening mode when THX is used with a 2-channel input signal.

PL II Movie: Apply to Dolby Pro Logic II Movie.

Neo:6 Cinema: Apply to Neo:6 Cinema.

■ c. THX Surr EX (Dolby D)

This is the same as see “THX Surround EX (Dolby Digital)” on page 60. It can be set even while a listening mode other than Dolby is selected.

■ d. DTS-ES

This is the same as see “THX Cinema (DTS/DTS-ES)” on page 60. It can be set even while a listening mode other than DTS is selected.

3-10. Mono Movie, 3-11. Enhance, 3-12. Orchestra, 3-13. Unplugged, 3-14. Studio-Mix, 3-15. TV Logic

These settings are for the DSP listening modes.

■ a. Front Effect

With this setting you can turn off the reverb for the front speakers. This is useful when playing live material that already contains live reverberation and the reverb added by the DSP listening mode simply blurs the original sound. When the Front Effect is turned off, no reverb is added to the front left, right, and center speakers and the original reverberation can be heard as it is.

On: Front Effect on (default).

Off: Front Effect off.

■ b. Reverb Level

With this setting you can adjust the amount of reverb to suit your listening environment, source material, and so on. The available settings are: Low, Middle (default), and High.

■ c. Reverb Time



With this setting you can adjust the reverb time to suit your listening environment, source material, and so on. The available settings are: Short, Middle (default), and Long.

The procedure for changing these settings is provided on page 68.

Advanced Setup—Continued

Setting Preferences

This section explains the items on the Preference menu.

- 1**  **Press the scroll wheel, and then press the [Setup] button.**
The main menu appears onscreen.
- 2**  **Use the Up/Down [▲]/[▼] buttons to select “4. Preference,” and then press the [Enter] button.**
The Preference menu appears.

-Advanced Menu -

4.Preference



4-1.Volume Setup

a.Volume Display :Absolute

b.Muting Level :-oodB

c.Maximum Volume :Off

d.Power On Volume :Last

Quit:|SETUP|
- 3**  **Use the Up/Down [▲]/[▼] buttons to select the menu items, and then press the [Enter] button.**
- 4**  **Use the Up/Down [▲]/[▼] buttons to select the settings, and use the Left/Right [◀]/[▶] buttons to set them.**
The settings are explained below.
- 5**  **Press the [Setup] button.**
The setup menu closes.

Note:

- This procedure can also be performed by using the DTR-8.4's [Setup] button, [▲]/[▼]/[◀]/[▶] buttons, and [Enter] button.

4-1. Volume Setup

■ **a. Volume Display**

With this preference you can choose how the volume level is displayed.

Absolute: Display range is 0 to 100.

Relative: Display range is $-\infty$ dB, -81 dB, -80 dB through $+16$ dB, $+17$ dB, and Max.

The absolute value 82 is equal to the relative value 0 dB.

■ **b. Muting Level**

This setting determines the volume level while the DTR-8.4 is muted (see page 52). It can be set to $-\infty$ dB (default) or between -50 dB and -10 dB in 10 dB steps.

■ **c. Maximum Volume**

With this preference you can prevent the volume being set too high by specifying a maximum volume level.

When the Volume Display preference is set to Absolute, the range is from 50 to 99. When it's set to Relative, the range is -32 dB through $+17$ dB. To specify no maximum volume, select “Off.”

■ **d. Power On Volume**

With this preference you can specify the volume setting to be used each time the DTR-8.4 is turned on.

When the Volume Display preference is set to Absolute, the range is from 0 to 100. When it's set to Relative, the range is $-\infty$ dB, -81 dB through $+18$ dB. To use the same volume level that was used when the DTR-8.4 was turned off, select “Last.”

4-2. Headphones Level

■ **a. Headphones Level**

With this preference you can specify the headphone volume relative to the main volume. This is useful if there's a volume difference between your speakers and your headphones. The headphone volume can be set between -12 dB and $+12$ dB.

Advanced Setup—Continued

4-3. OSD Setup

■ a. Background Color

With this preference you can select a background color for the onscreen setup menus (OSD). The available colors are: Blue 1, Blue 2, Green 1, Green 2, Magenta, Red 1, or Red 2.

■ b. Component Video

This preference determines whether or not the onscreen setup menus (OSD) are displayed on the TV connected to the COMPONENT VIDEO OUTPUT.

OSD On: OSD displayed.

OSD Off: OSD not displayed.

■ c. Immediate Display

This preference determines whether or not actions, such as selecting an input source, are displayed onscreen.

On: Actions displayed.

Off: Actions not displayed.

While a video signal from a video component is being output, actions are not displayed onscreen even if this preference is set to On.

■ d. Display Position

With this preference you can specify the position onscreen where you want actions (Immediate Display) to be displayed. There are ten positions from the top to the bottom of the screen.



4-4. OSD Position

■ OSD Position

With this preference you can specify the position onscreen where you want the onscreen setup menus (OSD) to appear. Use the [▲]/[▼]/[◀]/[▶] buttons to specify the position.

Naming Presets & Input Sources

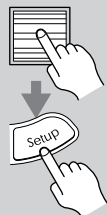
This section explains how to name radio presets and input sources. Names may consist of up to 10 characters.

- 1**  **Press the [Input] button, and then roll the scroll wheel to select the input source you want to name.**
If you want to name a radio preset, select that preset.
- 2**  **Press the scroll wheel, and then press the [Setup] button.**
The Basic menu appears onscreen.
- 3**  **Use the Up/Down [▲]/[▼] buttons to select “2. Input Setup,” and then press the [Enter] button.**
The Input Setup menu appears.
- 4**  **Use the Up/Down [▲]/[▼] buttons to select “4. Character Input,” and then press the [Enter] button.**
The Character Input menu appears.

```

-Advanced Menu-----
2. Input Setup -----
  Input: DVD -----

2-4.Character Input
  Input: DVD -----

a.Character Display
   :No  [00]
b.Character
   :    [00]

Press 0 to edit.
  0 to clear.

[▼][▲]      Quit: [SETUP]

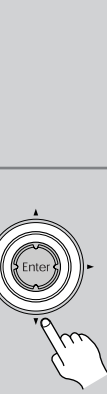
```
- 5**  **Use the Up/Down [▲]/[▼] buttons to select “a. Character Display,” and use the Left/Right [◀]/[▶] buttons to select “Yes.”**
When this setting is set to No, the default name is displayed. It must be set to Yes to display your custom name.

Advanced Setup—Continued

- 6** Use the Up/Down [▲]/[▼] buttons to select “b. Character,” and press the Right [▶] button to open the character input window. To delete the previous name, press the Left [◀] button.
- 7** Use the [▲]/[▼]/[◀]/[▶] buttons to select a character, and then press the [Enter] button. To move the cursor to the left, press the [Return] button. To move it to the right, press the [Enter] button. To delete a character, enter a space “-.”
- 8** Repeat step 7 until you’ve entered all 10 characters. The previous menu reappears. If the name you are entering consists of less than 10 characters, enter spaces “-” at the end to make it up to 10.
- 9** Press the [Setup] button. The setup menu closes.

Note:

- This procedure can also be performed by using the DTR-8.4’s input selector buttons, [Setup] button, [▲]/[▼]/[◀]/[▶] buttons, and [Enter] button.

Using IntelliVolume

With the IntelliVolume function you can specify an input level for each input source. This is useful if some of your AV components are louder or quieter than others.

- 1** Press the [Input] button, and then roll the scroll wheel to select the input source you want to set.

- 2** Press the scroll wheel, and then press the [Setup] button. The Basic menu appears onscreen.
- 3** Use the Up/Down [▲]/[▼] buttons to select “2. Input Setup,” and then press the [Enter] button. The Input Setup menu appears.
- 4** Use the Up/Down [▲]/[▼] buttons to select “5. IntelliVolume,” and then press the [Enter] button. The IntelliVolume menu appears.
- 5** Use the Left/Right [◀]/[▶] buttons to specify the level. The level can be set from -12 dB to +12 dB.
- 6** Press the [Setup] button. The setup menu closes.

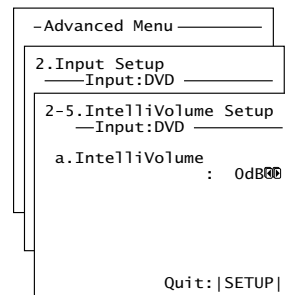

Note:

- This procedure can also be performed by using the DTR-8.4’s input selector buttons, [Setup] button, [▲]/[▼]/[◀]/[▶] buttons, and [Enter] button.

Net-Tune

About Net-Tune

The DTR-8.4 can be used as a Net-Tune client on a standard Ethernet network, allowing you to play music (MP3, WAV) stored on your network audio server through the DTR-8.4. If your network is connected to the Internet, you can also tune into Internet radio stations.

Internet Radio

With Internet radio you can:

- Listen to stations that use MP3 format streaming.
- Select stations by genre, location, or language.
- Preset up to 30 Internet radio stations.

Net-Tune

For audio delivery over Ethernet, Onkyo developed NTSP (Net-Tune System Protocol). Since it's based on the industry standard TCP/IP protocol, it's efficient and very responsive.

The network audio server supports the MP3 and WAV formats.

- **WAV:** high-quality, uncompressed, linear PCM.
- **MP3:** high-quality, compressed, small file size.

For more information about Net-Tune, see the following Integra Web sites.

- <http://www.integrahometheater.com/>

Network Requirements

■ Ethernet Network

The DTR-8.4's Ethernet port supports 10Base-T. For best results, a 100Base-T switched Ethernet network is recommended. Although it's theoretically possible to use a wireless network, due to unpredictable performance, it may not provide satisfactory results, so a wired network is recommended.

■ Ethernet Router

A router manages the network, routing data and supplying IP addresses. Your router must support the following:

- NAT (Network Address Translation). NAT allows several networked computers to access the Internet simultaneously via a single Internet connection. The DTR-8.4 needs Internet access for Internet radio.
- DHCP (Dynamic Host Configuration Protocol). DHCP supplies IP address information to network devices, allowing them to configure themselves automatically.
- A router with a 100Base-TX switch built-in is recommended.

Some routers have a modem built-in, and some ISPs require you to use specific routers. Please consult your ISP or computer dealer if you're unsure.

■ CAT5 Ethernet cable

Use a standard CAT5 Ethernet cable (straight-type).

■ Internet Access (for Internet radio)

To use Internet radio, your Ethernet network must have Internet access. A narrowband Internet connection (e.g., 56K modem, ISDN) will not provide satisfactory results, so a broadband connection is strongly recommended (e.g., cable modem, xDSL modem, etc). Please consult your ISP or computer dealer if you're unsure.

Net-Tune—Continued

Notes:

- To use Internet radio with the DTR-8.4, your broadband Internet connection needs to be up and running and able to access the Web. Please consult your ISP if you have any problems with your Internet connection.
- The DTR-8.4 uses DHCP and AutoIP to configure its network settings automatically. If you want to configure these settings manually, see page 82.
- The DTR-8.4 does not support PPPoE settings, so if you have a PPPoE-type Internet connection, you must use a PPPoE-compatible router.
- Depending on your ISP, you may need to specify a proxy server to use Internet radio. If your PC is configured to use a proxy server, use the same settings (see page 82).

Networking Your DTR-8.4

To connect the DTR-8.4 to your Ethernet network, plug one end of a CAT5 Ethernet cable into the ETHERNET (Net-Tune) port, and plug the other end into a LAN port on your router or switch.

The following diagram shows how you can connect the DTR-8.4 to your Ethernet network. Here it's connected to a LAN port on the router, which has a 4-port 100Base-TX switch built-in.

You can connect any number of DTR-8.4s to the network, and the network audio server can serve up to three clients simultaneously, so you can enjoy Net-Tune in three separate rooms simultaneously. The following diagram shows a Net-Tune network with two DTR-8.4s.

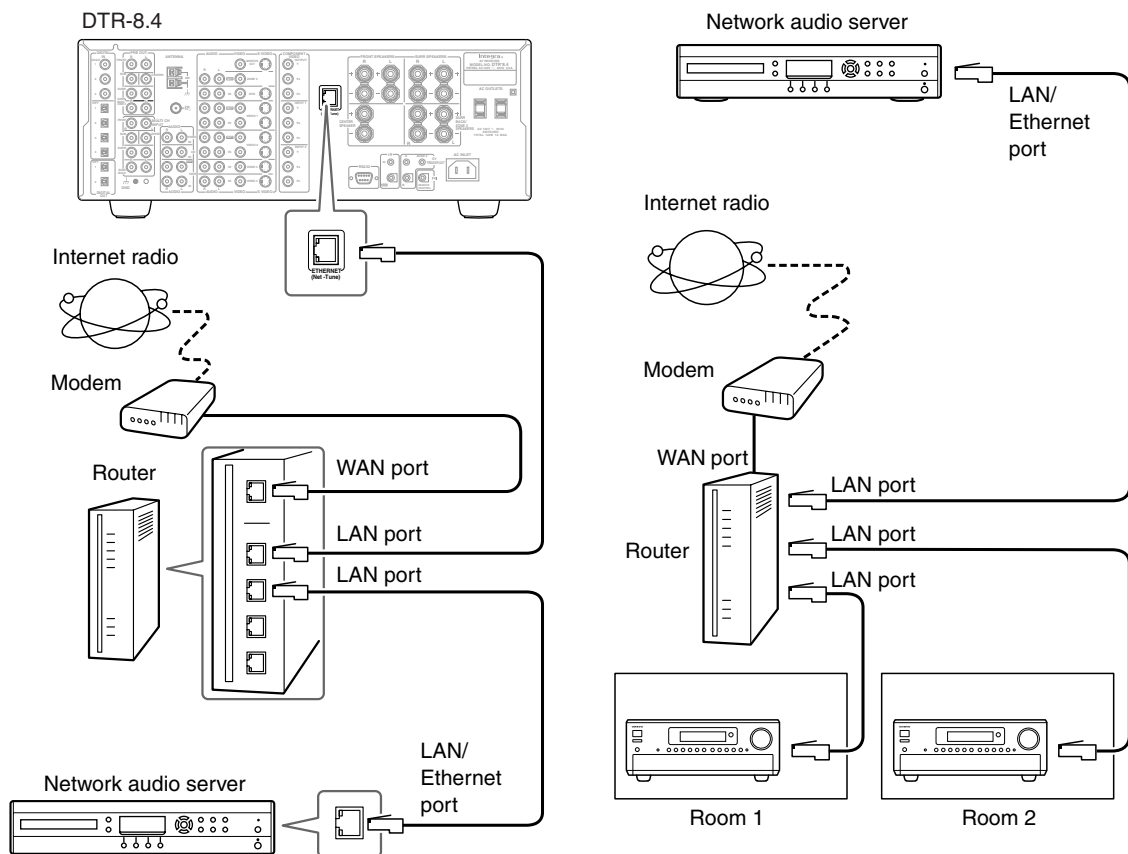

Net-Tune—Continued

Using Internet Radio

This section explains how to use Internet radio. You can select stations by genre, location, or language. To use Internet radio, you must connect the DTR-8.4 to a network with Internet access (see page 75).

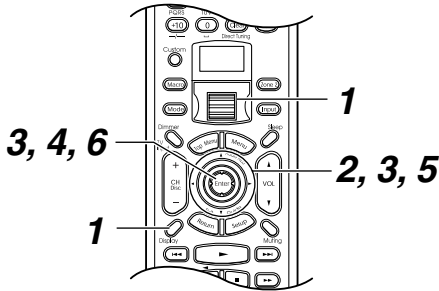

1 	<p>While either the [Input] button nor [Mode] button is illuminated, rolling the scroll wheel to select IRD (Internet Radio).</p> <p>“NET-T” appears on the bottom line. If the Internet Radio menu doesn’t appear onscreen, press the remote controller’s [Display] button.</p>
2 	<p>Use the Up/Down [▲]/[▼] buttons to select Genres, Location, or Language.</p> <div style="border: 1px solid black; padding: 5px; margin: 5px 0;"> <p>i Net Radio(Menu)</p> <p>1. Genres 2. Location 3. Language</p> </div>
3 	<p>Press the [Enter] button.</p> <p>The DTR-8.4 accesses the XiVA-Net online database to see what radio stations are available. This may take awhile.</p> <p>If you select Genres: When the Genre menu appears, use the Up/Down [▲]/[▼] buttons to select a genre, and then press the [Enter] button. When the subgenre menu appears, use the Up/Down [▲]/[▼] buttons to select a subgenre.</p> <p>If you select Location: When the Location menu appears, use the Up/Down [▲]/[▼] buttons to select a location.</p>

	<p>If you select Language: When the Language menu appears, use the Up/Down [▲]/[▼] buttons to select a language. If no information is found, “No List” appears onscreen. In this case, press the Left [◀] button to return to the previous menu.</p>
4 	<p>Press the [Enter] button. A list of available radio stations appears onscreen.</p>
5 	<p>Use the Up/Down [▲]/[▼] buttons to select a radio station. To return to the previous menu, press the Left [◀] button.</p>
6 	<p>Press the [Enter] button. The DTR-8.4 connects to the selected radio station and begins buffering audio data, the progress of which is displayed in percent. When buffering reaches 100%, playback starts.</p> <div style="border: 1px solid black; padding: 5px; margin: 5px 0;"> <p>Buffering 90%</p> </div> <p>To display information about the current radio station on the DTR-8.4, as shown below, use the Up/Down [▲]/[▼] buttons. If no information is available, “No Info” appears.</p> <div style="border: 1px solid black; padding: 5px; margin: 5px 0;"> <p>Station ONK</p> </div> <p>If you’re using the onscreen display (OSD), the available information appears as shown below.</p> <div style="border: 1px solid black; padding: 5px; margin: 5px 0;"> <p>iNet Radio Station ONK 7ch Track: Station ONK Live Program: Station ONK Live Artist: Rea10nkyoNet.com Data: WMA 20kbps Tuned</p> </div>

Note:



- If you’re using a narrowband Internet connection (e.g., 56K modem, ISDN), depending on the station, Internet radio may not work satisfactorily. Use a broadband connection for best results (e.g., cable modem, xDSL modem, etc).

Net-Tune—Continued

Presetting Internet Radio Stations

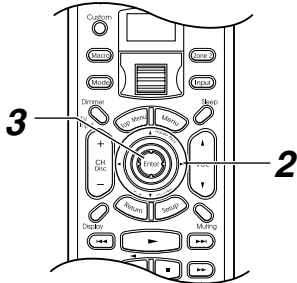
You can store up to 30 Internet radio stations as presets.

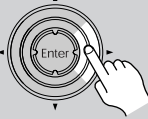

- | | |
|---|--|
| 1 | Select the Internet radio station that you want to preset. |
| 2
 | Press the Right [▶] button.
The preset number flashes for about five seconds. |
| 3
 | While the preset number is flashing, press the [Enter] button to store the preset.
The preset number stops flashing. |

Selecting Internet Radio Presets

You can select previously stored Internet radio presets as follows.

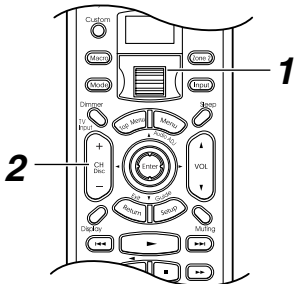

- | | |
|---|---|
| 1
 | While either the [Input] button nor [Mode] button is illuminated, rolling the scroll wheel to select IRD (Internet Radio). |
|---|---|

- | | |
|---|---|
| 2
 | Use the remote controller's [CH/Disc] button to select the preset. |
|---|---|

On the DTR-8.4, use the Preset [◀]/[▶] buttons to select the presets.

The station name is displayed for several seconds, and then the buffering progress is displayed.

Buffering 90%



Station ONK

When buffering reaches 100%, playback starts.

Deleting Internet Radio Presets

This section explains how to delete Internet radio presets.

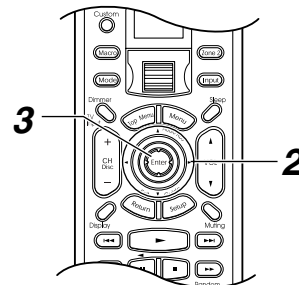

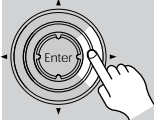

- | | |
|---|--|
| 1 | Select the preset that you want to delete, as explained previously. |
| 2
 | Press the Right [▶] button.

Preset Erase |
| 3
 | Press the [Enter] button to delete the preset.
The selected preset is deleted. |

Net-Tune—Continued

Playing network audio server Tracks

This section explains how to select and play tracks on a network audio server through the DTR-8.4. You can select tracks by album, artist, genre, or playlist.

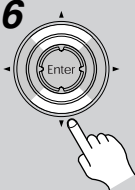
- 1** Turn on your network audio server.
- 2** Turn on the DTR-8.4.
- 3**  While neither the [Input] button nor [Mode] button is illuminated, roll the scroll wheel to select MSRV (Music Server).
“NET-T” appears on the bottom line.
While the DTR-8.4 connects to the network, and then the server, the messages “Network Starting...” and “Connecting...” appear.
When a connection is established, the track you played last time is selected ready for playback.
- 4**  Press the remote controller's [Display] button.
The server menu appears onscreen.
- 5** Use the [Album], [Artist], [Genre], or [Playlist] button to select a menu.
Alternatively, use the Up/Down [▲]/[▼] buttons to select a menu, and then press [Enter].
The album, artist, genre, or playlist menu appears onscreen.
If you selected the artist or genre menu, use the Up/Down [▲]/[▼] buttons to select an artist or genre, and then press [Enter]. A menu of tracks by that artist, or of that genre is displayed.
- 6**  Use the Up/Down [▲]/[▼] buttons to select items on the menu.
You can select menu items by number or by first letter. See “Selecting Items by Letter” on page 80.

7



Press the [Enter] or [▶] button to start playback.

To display information about the current track on the DTR-8.4, as shown below, use the Up/Down [▲]/[▼] buttons.

```
1r 1n20s
```

Information appears on the onscreen display (OSD) as shown below.

```
Music Server      Play
Track: 1/12      1m20s>
      My sweet candy
Album:
      My Best 100
Artist:
      Happy PanPot
Data:
      MP3 160kbps
```

To return to the previous menu during playback, press the Left [◀] button.

To stop or pause playback, press the remote controller's Stop [■] or Pause [⏸] button respectively.

To select the next track, press the Next [▶▶] button. To select the beginning of the current track, press the Previous [◀◀] button. To select the previous track, press the Previous [◀◀] button twice.

You can select tracks by number during playback with the remote controller's number buttons, as follows:

To select track #3, press [3].

To select track #10, press 0.

To select track #37, press [CAPS], [3], and 7.

To select track #123, press [CAPS] twice, and then [1], [2], and [3].

To fast forward or fast reverse, press and hold the remote controller's FF [▶▶] or FR [◀◀] button respectively. If you fast reverse all the way to the beginning of a track, playback starts.

Notes:

- When you connect the DTR-8.4 to a network for the very first time, it connects to the first network audio server it finds. If you're using several servers, use the Select Server setting to select another server (see page 81).

Net-Tune—Continued

- If the message “No Tracks” appears, this means that no information can be retrieved from the network audio server. In this case, you need to record some music on your network audio server.
- If the message “Disconnected” appears, this means that the DTR-8.4 cannot connect to the network audio server. In this case, check the network audio server, and DTR-8.4 connections. It may be that the DTR-8.4 cannot find the network audio server that it used last time, in which case, use the Select Server setting to select another server (see page 81).

Selecting Items by Letter

You can select items on the album, artist, genre, and playlist menus by entering the first letter of the item's name.

1	<p>Select the album, artist, genre, or playlist menu, as explained previously.</p>
2	<p>Press the remote controller's [Caps] button repeatedly to select an input mode:</p> <p>Uppercase: In this mode, the number buttons input uppercase letters. For example, press the [2] button repeatedly to enter <i>A</i>, <i>B</i>, or <i>C</i>. The first item in the menu that begins with the entered letter will be selected.</p> <p>Lowercase: In this mode, the number buttons input lowercase letters. For example, press the [2] button repeatedly to enter <i>a</i>, <i>b</i>, or <i>c</i>. The first item in the menu that begins with the entered letter will be selected.</p> <p>Number: In this mode, the number buttons input numbers. For example, press the [2] button and any item in the menu that begins with the number 2 will be selected.</p>
3	<p>Use the Up/Down [▲]/[▼] buttons to select a track, and then press the [Enter] button to start playback.</p> <p>Press the [Delete] button to delete the entered letter or number.</p>

Playing Net-Tune Tracks Randomly

This section explains how to play a random selection of tracks from the current artist, album, genre, or playlist menu.

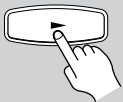
1	<p>Random</p> 	<p>While playback is stopped, press the remote controller's [Random] button.</p>
2		<p>Press the Play [▶] button to start random playback</p>

Playing Net-Tune Tracks Repeatedly

This section explains how to play one or all tracks on the current artist, album, genre, or playlist menu repeatedly.

1	<p>Repeat</p> 	<p>Press the remote controller's [Repeat] button repeatedly to select a repeat mode:</p> <p>Repeat 1: Repeat the current track.</p> <p>Repeat All: Repeat all tracks on the current menu.</p> <p>Repeat Off: Repeat function off.</p>
----------	--	---

Notes:

- Pressing the DTR-8.4's [Display] button displays the current listening mode.
- Although you are operating the DTR-8.4, the commands are actually being sent to the network audio server. Sometimes it may take the server awhile to respond to operations performed on the DTR-8.4.

Net-Tune—Continued

Music Server Settings

This section explains how to select a network audio Server and how to choose the amount of track information that appears onscreen (OSD) during Net-Tune playback.

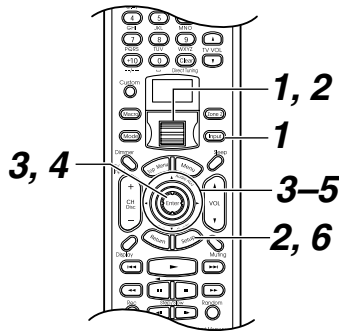

- 1** Press the [Input] button, and then roll the scroll wheel to select either IRD or MSRV.

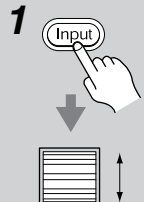

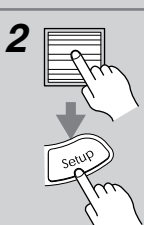
- 2** Press the scroll wheel, and then press the [Setup] button. If the Basic menu appears, use the Down [▼] button to select Advanced Menu, and press the [Enter] button to display the Advanced menu.

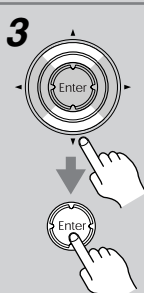
- 3** Use the Up/Down [▲]/[▼] buttons to select “2. Input Setup,” and then press the [Enter] button. The Input Setup menu appears.

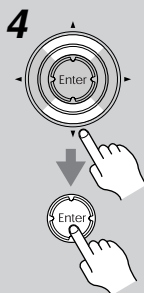

- 4** Use the Up/Down [▲]/[▼] buttons to select “1. Music Server” or “2. Playback OSD Display,” and then press the [Enter] button.

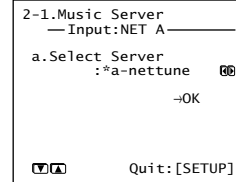

The Music Server or Playback OSD Display menu appears.

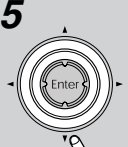

- 5** If you select “1. Music Server”: Use the Up/Down [▲]/[▼] buttons to select “a. Select Server,” and use the Left/Right [◀]/[▶] buttons to select a server.



Servers that are up and running have an asterisk (*) before their name.

If a server is not listed, try restarting it.

When you’ve selected a server, use the Down [▼] button to select “OK,” and then press [Enter].

This completes the server selection procedure.

- 6** If you select “2. Playback OSD Display”: Use the Up/Down [▲]/[▼] buttons to select “a. Playback OSD Display,” and use the Left/Right [◀]/[▶] buttons to select:

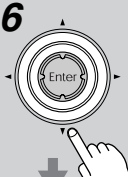

Full: All track information is displayed during playback.

Simple: Only two lines of track information are displayed during playback.

Off: Nothing is displayed during playback.

Press the [Setup] button.

The setup menu closes.

Note:

- You must select the IRD or MSRV input source to make these settings. The 1. Music Server menu item is not available when a different input source is selected.
- This procedure can also be performed by using the DTR-8.4’s input selector buttons, [Setup] button, [▲]/[▼]/[◀]/[▶] buttons, and [Enter] button.
- The track information display is not affected by the Display Position setting on page 73.

Net-Tune—Continued

Network Settings

This section explains how to manually configure the DTR-8.4's network settings.

If your router's DHCP server is enabled, by default the DTR-8.4 is set use DHCP to configure itself automatically (i.e., the DHCP/AUTO IP setting is On), so you don't need to change any of the settings on the "5. Network Setup" menu. If your router's DHCP server is disabled, for example, you're using static IP addresses, you'll need to configure these settings yourself. A knowledge of Ethernet networking is essential.

What's DHCP/AutoIP?

DHCP (Dynamic Host Configuration Protocol) and Auto IP (Automatic IP Addressing) are services used by routers, computers, the DTR-8.4, and other devices to automatically configure themselves on the network.

What's DNS?

The DNS (Domain Name System) translates domain names into IP addresses. For example, when you enter a domain name such as *www.integrahometheater.com* in your Web browser, before accessing the site, your browser uses DNS to translate this into an IP address, in this case 63.148.251.142.

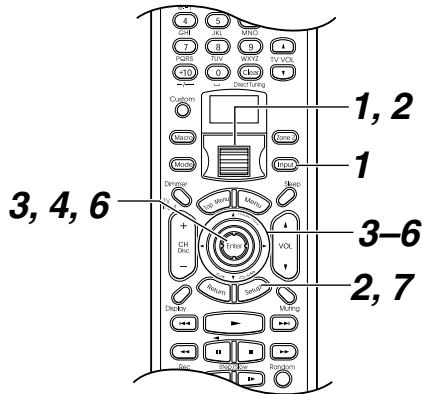

<p>1</p>	<p>Press the [Input] button, and then roll the scroll wheel to select either "IRD" or "MSRV."</p>
<p>2</p>	<p>Press the scroll wheel, and then press the [Setup] button. If the Basic menu appears, use the Down [▼] button to select Advanced Menu, and press the [Enter] button to display the Advanced menu.</p>

<p>3</p>	<p>Use the Up/Down [▲]/[▼] buttons to select "5. Network Setup," and then press the [Enter] button. The Network Setup menu appears.</p> <div data-bbox="1002 499 1236 678" style="border: 1px solid black; padding: 5px;"> <pre>5. Network Setup 1. IP Address 2. Proxy Setup 3. MAC Address 4. Client Setup -Save Settings [▼][▲][ENTER]Quit:[SETUP]</pre> </div>
-----------------	--

<p>4</p>	<p>Use the Up/Down [▲]/[▼] buttons to select the menu items, and then press the [Enter] button. The IP Address menu is shown here.</p>
-----------------	---

<p>5</p>	<p>Use the Up/Down [▲]/[▼] buttons to select the settings, and use the Left/Right [◀]/[▶] buttons to set them. To enter an IP address, select the setting, and then press the [Enter] button. The [▲]/[▼]/[▶]/[◀] buttons can then be used to enter numbers. Press the [Enter] button again to set the number. The settings are explained below.</p>
-----------------	---

<p>6</p>	<p>When you've completed the settings on any menu, press the [Return] button to return to the "5. Network Setup" menu, use the Up/Down [▲]/[▼] buttons to select "Save Settings," and then press [Enter]. Don't turn off the DTR-8.4 while the settings are being saved (about 2 seconds), otherwise they'll be lost.</p>
-----------------	--

<p>7</p>	<p>Press the [Setup] button. The setup menu closes.</p>
-----------------	--

Net-Tune—Continued

Note:

- This procedure can also be performed by using the DTR-8.4's input selector buttons, [Setup] button, [▲]/[▼]/[◀]/[▶] buttons, [Enter], and [Return] button.

5-1. IP Address

■ a. DHCP/AUTO IP

This setting determines whether or not the DTR-8.4 uses DHCP and AutoIP to automatically configure the IP Address, SUBNET Mask, Gateway, and DNS Server settings.

On: Use DHCP/Auto IP (default).

Off: Don't use DHCP/Auto IP.

If you select Off, you must configure the IP Address, SUBNET Mask, Gateway, and DNS Server settings yourself. Otherwise, Net-Tune won't work.

■ b. IP Address

You must specify an IP address if you set the DHCP/AUTO IP setting to Off.

Enter a static IP address provided by your ISP.

The IP address must be within the following ranges. Net-Tune will not work with IP addresses outside of these ranges.

Class A: 10.0.0.0 to 10.255.255.255

Class B: 172.16.0.0 to 172.31.255.255

Class C: 192.168.0.0 to 192.168.255.255

Most routers use Class C IP addresses.

■ c. SUBNET Mask

You must specify the subnet mask IP address if you set the DHCP/AUTO IP setting to Off.

Enter the subnet mask IP address provided by your ISP (typically: 255.255.255.0).

■ d. Gateway

You must enter a gateway IP address if you set the DHCP/AUTO IP setting to Off.

Enter the gateway IP address provided by your ISP.

■ e. 1st DNS Server, f. 2nd DNS Server

You must enter the DNS server IP addresses if you set the DHCP/AUTO IP setting to Off.

Enter the DNS server IP addresses provided by your ISP. If your ISP supplied only one DNS address, enter it in the e. 1st setting.

5-2. Proxy Setup

If you use a proxy server with your Internet connection, you must enter the proxy server settings provided by your ISP.

■ a. Proxy Server

This setting determines whether or not the DTR-8.4 uses a proxy server for Internet radio.

On: Use proxy server.

Off: Don't use proxy server.

■ b. Proxy Address

You must enter an IP address for a proxy server if you set the Proxy Server setting to On.

Enter the proxy server IP address provided by your ISP.

■ c. Proxy Port

You must enter an IP address for a proxy server if you set the Proxy Server setting to On.

Enter the proxy port IP address provided by your ISP.

5-3. Mac Address

■ a. MAC Address

You can check the DTR-8.4's MAC (Media Access Control) address. This address cannot be changed.

5-4. Client Setup

A network typically consists of a server and several clients. On a Net-Tune network, the network audio server is the server and the DTR-8.4 is the client.

■ a. Client Name

You can check the DTR-8.4's client name. This name is preset at the factory and cannot be changed.

■ b. Wakeup on LAN

This setting determines whether or not the DTR-8.4 maintains its network connection while its on Standby.

On: Maintain network connection.

Off: Close network connection while on Standby (uses less power).

■ c. NTSP Port

This is the TCP/IP port number that is used for communication with the network audio server. To enable communication, this port number must agree with the port number setting in network audio server. Unless you have a special reason for doing so, don't change this number.

Zone 2

Connecting Zone 2

With Zone 2 you can enjoy one input source in the main room and a different source in another room. With Zone 2 you can enjoy one input source in the main room and a different source in another room.

There are three connection methods: using a receiver/integrated amp in Zone 2, using a power amp in Zone 2, or using only a pair of speakers in Zone 2.

Using a Receiver/Integrated Amp in Zone 2

With this connection method you can use 7.1 surround sound in the main room and play a different AV source in Zone 2. Zone 2's volume is adjusted on the receiver/integrated amp.

- Set the Surr Back/Zone2 setting to Surr Back (see page 86).
- Use an RCA/phono audio cable to connect the DTR-8.4's AUDIO ZONE 2 OUT L/R outputs to analog audio inputs on your receiver/integrated amp.
- Use a composite video cable to connect the DTR-8.4's VIDEO ZONE 2 OUT to a composite video input on your Zone 2 TV.

Connect your Zone 2 speakers to the speaker terminals on your receiver/integrated amp.

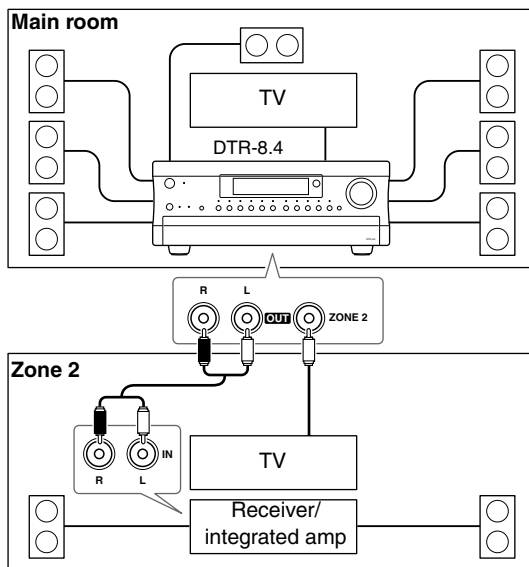

Using a Power Amp in Zone 2

With this connection method you can use 5.1 surround sound in the main room and play a different source in Zone 2. Zone 2's volume is adjusted on the DTR-8.4.

- Set the Surr Back/Zone2 setting to Zone 2 (see page 86).
- Use an RCA/phono audio cable to connect the DTR-8.4's PRE OUT SURR BACK/ZONE 2 L/R outputs to the analog audio inputs on your power amp.

- Use a composite video cable to connect the DTR-8.4's VIDEO ZONE 2 OUT to a composite video input on your Zone 2 TV.
- Connect your Zone 2 speakers to the speaker terminals on your power amp.

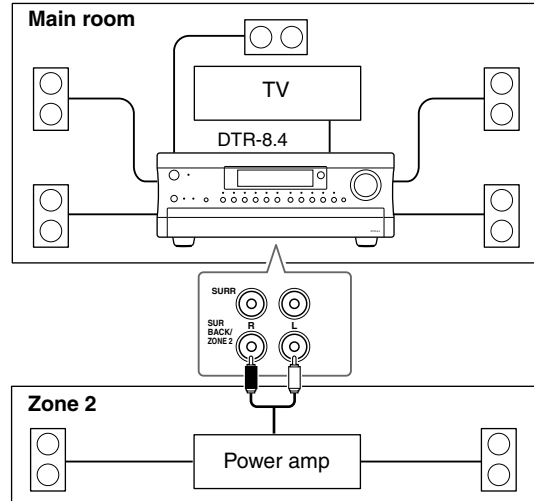

Using Only Speakers in Zone 2

With this connection method you can use 5.1 surround sound in the main room and play a different AV source in Zone 2. Zone 2's volume is adjusted on the DTR-8.4.

- Set the Surr Back/Zone2 setting to Zone 2 (see page 86).
- Connect your Zone 2 speakers to the DTR-8.4's SURR BACK/ZONE 2 SPEAKERS terminals.
- Use a composite video cable to connect the DTR-8.4's VIDEO ZONE 2 OUT to a composite video input on your Zone 2 TV.

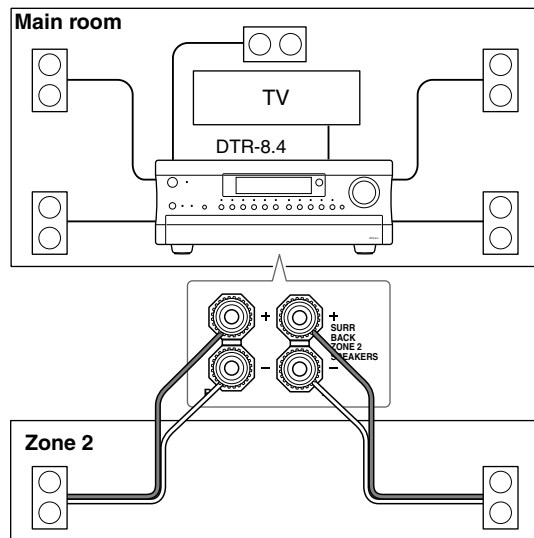

Zone 2—Continued

Using the 12V Trigger

While Zone 2 is active on the DTR-8.4, the ZONE 2 12V TRIGGER OUT outputs 12 volts (100 milliamperes max). By connecting this to the 12-volt trigger input on, say, a power amp in Zone 2, the power amp will turn on and off automatically when Zone 2 is turned on and off on the DTR-8.4.

Using the Remote Control in Zone 2

To use the remote controller to control the DTR-8.4 from Zone 2, you'll need one of the following commercially available multiroom remote control kits:

- Onkyo Multiroom Kit (IR remote controller extension system)
- Multiroom AV distribution and control systems such as those made by Niles and Xantech.

These kits can also be used when the DTR-8.4 is not in line of sight of the remote controller, for example, when it's installed inside a cabinet.

You can set the transmission signal format to RF for use with the optional RF Receiver (see page 98).

Using a Multiroom Kit with Zone 2

In the following diagram, an IR receiver picks up the infrared signals from the remote controller in Zone 2 and feeds them to the DTR-8.4 in the main room via the connecting block.

- On the Remote Setup menu, set the Position setting to "Zone 2" (see page 48).

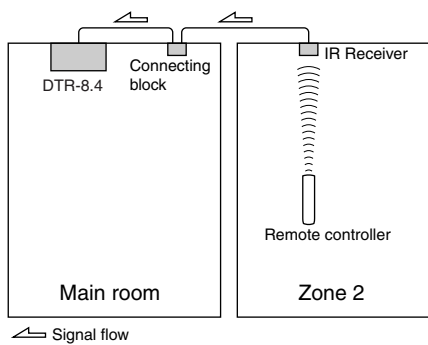

Connect the miniplug cable from the connecting block to the DTR-8.4's IR IN socket as shown below.

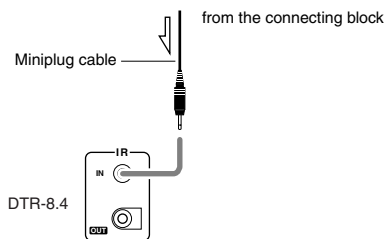

Using a Multiroom Kit with a Cabinet

In the following diagram, an IR receiver picks up the infrared signals from the remote controller and feeds them to the DTR-8.4 in the cabinet via the connecting block.

- On the Remote Setup menu, set the Position setting to "Main" (see page 48).

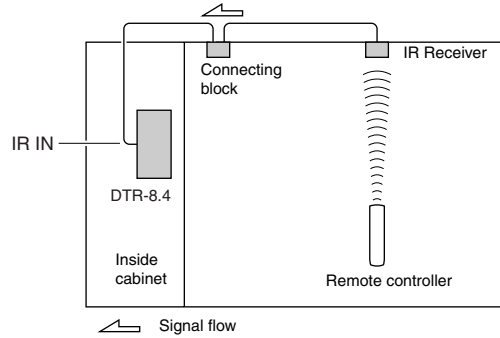

Using a Multiroom Kit with Other Components

In the following diagram, an IR emitter is connected to the DTR-8.4's IR OUT socket and placed in front of the other component's remote control sensor. Only infrared signals received at the IR IN socket are fed to the other component. Signals picked up by the DTR-8.4's remote control sensor are not passed on.

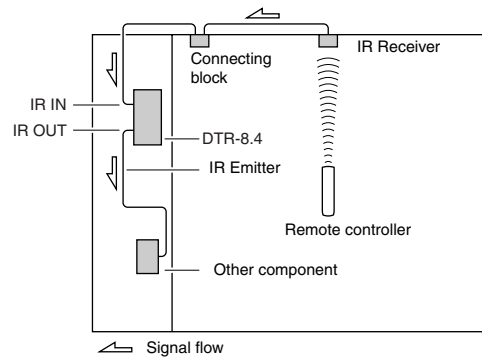

Connect the IR emitter to the DTR-8.4's IR OUT socket as shown below.

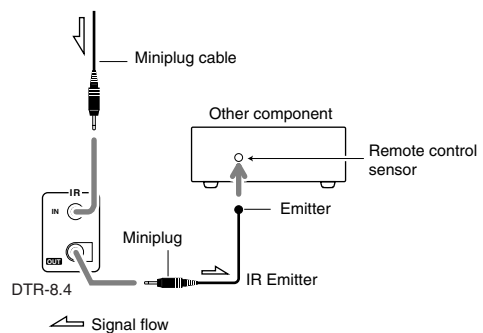

Zone 2—Continued

Setting the Surr Back/Zone 2 Outputs

This section explains how to set the PRE OUT SURR BACK/ZONE 2 outputs and the SURR BACK/ZONE 2 SPEAKERS terminals for use as surround back outputs or Zone 2 outputs.

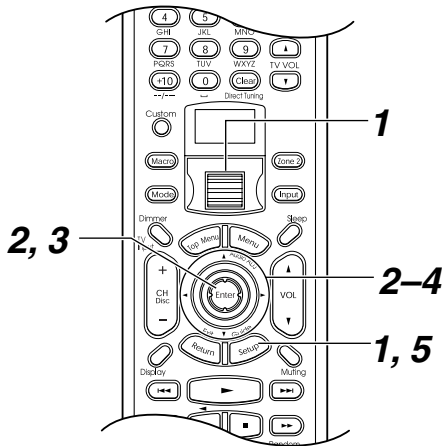

1	<p>Press the scroll wheel, and then press the [Setup] button. If the Basic menu appears, use the Down [▼] button to select Advanced Menu, and press the [Enter] button to display the Advanced menu.</p>
2	<p>Use the Up/Down [▲]/[▼] buttons to select "0. Hardware Setup," and then press the [Enter] button. The Hardware Setup menu appears.</p>
3	<p>Use the Up/Down [▲]/[▼] buttons to select "2. Surr Back/Zone2," and then press the [Enter] button. The Surr Back/ Zone2 menu appears.</p> <div style="border: 1px solid black; padding: 5px; margin-top: 10px;"> <pre> 0-2.Surr Back/Zone2 ----- a.Surr Back/Zone2 :Surr BackⓈ Quit: [SETUP] </pre> </div>

4	<p>Use the Left/Right [◀]/[▶] buttons to select: Surr Back: Use the SURR BACK/ZONE 2 outputs (SPEAKERS and PRE OUT) as surround back outputs. Select this option when connecting a receiver/integrated amp in Zone 2 (see page 84). Zone 2: Use the SURR BACK/ZONE 2 outputs (SPEAKERS or PRE OUT) for Zone 2. Select this option when connecting a power amp or only speakers in Zone 2 (see page 84).</p>
5	<p>Press the [Setup] button. The setup menu closes.</p>

Note:

- When the SURR BACK/ZONE 2 outputs (SPEAKERS and PRE OUT) are set to Zone 2, listening modes that need surround back speakers (i.e., Dolby Digital EX, DTS-ES, and THX Surround EX) are not available.
- This procedure can also be performed by using the DTR-8.4's [Setup] button, [▲]/[▼]/[◀]/[▶] buttons, and [Enter] button.

Zone 2—Continued

Controlling Zone 2

The section explains how to turn on, select an input source, and adjust the volume for Zone 2.

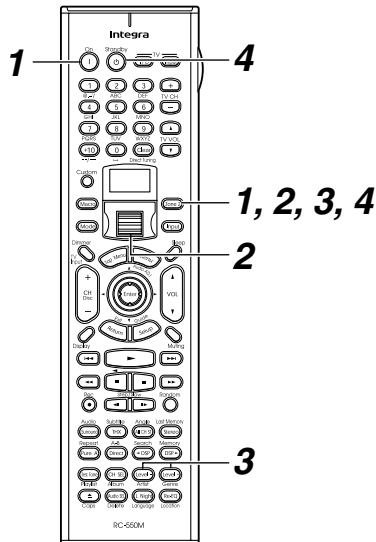

3 To adjust the Zone 2 volume with the remote controller, press the **[Zone 2]** button, and then use the Level **[+]**/**[-]** buttons.

To do this on the DTR-8.4, use the **Zone 2 Level [◀] [▶]** buttons. If your Zone 2 receiver/integrated amp is connected to the DTR-8.4's AUDIO ZONE 2 OUT L/R outputs, use the volume control on the receiver/integrated amp.

4 To turn off Zone 2 with the remote controller, press the **[Zone 2]** button followed by the **[Standby]** button.

To do this from the DTR-8.4, press the **[Zone 2]** button, and then press the **[Off]** button within eight seconds.

1 Point the remote controller at the DTR-8.4 and press the **[Zone 2]** button, make sure the **[Zone 2]** button is illuminated, then followed by the **[On]** button. This activates Zone 2 and, if connected to the DTR-8.4's 12V TRIGGER OUT, turns on the Zone 2 amp.

2 To select the Zone 2 input source with the remote controller, press the **[Zone 2]** button and then roll the scroll wheel. The name of the selected Zone 2 source appears on the display. To do this on the DTR-8.4, press the **[Zone 2]** button, and then press an input selector button within eight seconds. If you select AM or FM, you can use the remote controller's **[CH/Disc]** button to select the presets. To set the main room and Zone 2 sources simultaneously, press the **[Zone 2]** button repeatedly until "Z2 Sel: SOURCE" appears on the display. Now use the scroll wheel or input selector buttons to select the source.

Notes:

- If the Sleep function has been set, any Zone 2 component will turn off along with the DTR-8.4 when the specified sleep time expires. To use the Sleep function with Zone 2 only, set the Sleep function and then set the DTR-8.4 to Standby.
- Only analog input sources are output by the PRE OUT SURR BACK/ZONE 2 outputs and the SURR BACK/ZONE 2 SPEAKERS terminals. Digital input sources are not output. If no sound is heard when an input source is selected, check if it's connected to analog inputs.
- Since the Zone 2 function and the REC OUT outputs use the same circuitry, if the **[Rec Out]** button is pressed, Zone 2 will be turned off.
- When the SURR BACK/ZONE 2 outputs (SPEAKERS/PRE OUT) are set to Zone 2 (page 86), listening modes that need surround back speakers (i.e., Dolby Digital EX, DTS-ES, and THX Surround EX) are not available.
- While Zone 2 is active, **RI** functions will not work.
- While Zone 2 is active, the Pure Audio listening mode cannot be selected for the main room.
- You can't select different radio bands for Zone 2 and the main room. For example, if you select FM for the main room, then FM will also be selected for Zone 2.

Using the Remote Controller with Other Components

You can use the DTR-8.4's remote controller to control your other AV components, including those made by other manufacturers. To do this you can:

- Enter a remote control code for the component that you want to control (e.g., DVD, TV, VCR).
- Learn commands directly from the other component's remote controller (see page 93).
- Use the Macro function to learn a sequence of actions (see page 94).
- You can also edit the remote controller modes (see page 96).

Entering a Remote Control Code

By entering the appropriate remote control code for each of your components, you can control each component by selecting the relevant remote controller mode: DVD, TV, VCR, CBL (cable), or SAT (satellite).

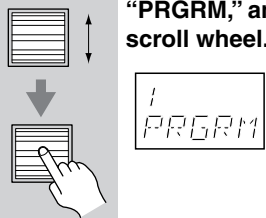
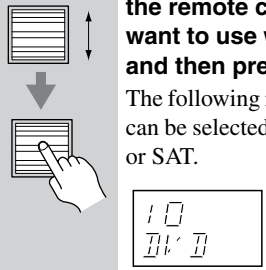
1	<p>Look up the appropriate remote control code for the component. See "Remote Control Codes" on page 89</p>
2 <small>Custom</small>	<p>Press and hold down the [Custom] button for more than three seconds. The remote controller enters Custom mode.</p>
3	<p>Roll the scroll wheel to select "PRGRM," and then press the scroll wheel.</p> 
4	<p>Roll the scroll wheel to select the remote controller mode you want to use with the component, and then press the scroll wheel. The following remote controller modes can be selected: DVD, TV, VCR, CBL, or SAT.</p> 

5

Use the number buttons to enter the 4-digit remote control code.

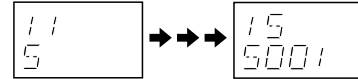

If the code is accepted, the following appears on the display for awhile, and then the normal display reappears.

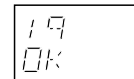

If the code is not accepted, after the message "RETRY" has been displayed, the code entry display reappears, and you should try entering the code again. To cancel this procedure at any point, press the [Custom] button.

6

Select the remote controller mode, point the remote controller at the component, and check its operation.

The remote controller buttons that can be used in DVD mode are shown on page 16. Those that can be used with the TV, VCR, CBL, and SAT modes are listed on pages 91 and 92.

Remote Control Codes for an Integra/Onkyo DVD Player

The remote control code that you use with an Integra/Onkyo DVD player depends on whether it's connected via **RI**, as follows:

- 5001:** Use this code if you've connected an **RI** cable and an RCA/phono analog audio cable to your DVD player. This is the default setting, so if you're using **RI**, you don't need to change it. Point the remote controller at the DTR-8.4 to operate the DVD player.
- 5002:** Use this code if your DVD player doesn't have an **RI** socket, or you're not using **RI**. Point the remote controller at the DVD player to operate it.

Using the Remote Controller with Other Components—Continued

Remote Control Codes

When two or more codes are given, try each one in turn, and choose the one that works best.

DVD (DVD player)	
Manufacturer	Control code
Aiwa	5010
Apex	5015, 5016
Denon	5017, 5020
GE	5003
Hitachi	5009
Integra	5001, 5002
Integra Research	5001, 5002
JVC	5023
Kenwood	5017
Magnavox	5004
Marantz	5025, 5026
Mitsubishi	5005
Onkyo	5001, 5002
Panasonic	5011, 5017, 5020
Philips	5004
Pioneer	5006
Proscan	5003
RCA	5003
Sanyo	5012
Sony	5007, 5013
Technics	5020
Thomson	5022, 5024
Toshiba	5008
Xbox	5022
Yamaha	5020
Zenith	5014

SAT (satellite receiver)	
Manufacturer	Control code
Dishnet	4008
Echostar	4010
GE	4001, 4002
General Instruments	4003
Hughes Network Systems	4011
JVC	4009
Panasonic	4006
Primestar	4007
Proscan	4001, 4002
RCA	4001, 4002
Sony	4005
Toshiba	4004

CBL (cable receiver)	
Manufacturer	Control code
ABC	3001, 3002
Archer	3006
Cableview	3004
Contec	3009
Eastern	3010
GE	3001, 3002
Gemini	3011
General Instruments	3002
Hamlin	3012
Hitachi	3002
Jerrold	3002, 3011, 3013

CBL (cable receiver)	
Manufacturer	Control code
Magnavox	3014
Memorex	3015
Movie Time	3016
NEC	3003
NSC	3016
Oak	3009
Panasonic	3020
Philips	3007, 3008, 3014
Pioneer	3017
Proscan	3001, 3002
RCA	3004, 3020
Realistic	3006
Samsung	3017
Signature	3002
Sprucer	3020
Standard Component	3018
Starcom	3011
Stargate	3011
Tocom	3013
Universal	3005, 3006
View Star	3009, 3014, 3016
Zenith	3019

VCR	
Manufacturer	Control code
Aiwa	2012
Akai	2003, 2004
Bell & Howell	2007
Canon	2010, 2011
Carver	2014
Citizen	2008, 2009
Colortyme	2005
Craig	2008
Curtis Mathes	2001, 2005, 2008, 2009, 2010, 2011
Daewoo	2012
Dimensia	2001
Emerson	2003, 2010, 2012
Fisher	2007
Fuji	2004, 2010
Funai	2012
Garrard	2012
GE	2001, 2002, 2008, 2010, 2011
GoldStar	2005, 2009
Gradiente	2012
Harman Kardon	2005
Hitachi	2013
JC Penney	2005, 2006, 2007, 2008, 2011, 2013, 2014
Jensen	2013
JVC	2005, 2006, 2007, 2009
Kenwood	2005, 2006, 2007, 2009
Kodak	2010
Magnavox	2010, 2011, 2014
Marantz	2005, 2006, 2007, 2009, 2010, 2014
Matsushita	2010
Memorex	2007, 2008, 2010, 2012
Minolta	2013
Mitsubishi	2013
Motorola	2010
MTC	2008
Multitech	2008, 2012

VCR	
Manufacturer	Control code
NEC	2005, 2006, 2007, 2009
NOBLEX	2008
Olympus	2010
Optonica	2017
Panasonic	2010, 2011
Pentax	2013
Pentax Research	2009
Philco	2010, 2011, 2014
Philips	2010, 2014, 2017
Pioneer	2006, 2013
Proscan	2001, 2002
Quasar	2010, 2011
Radio Shack	2017
Radio Shack/Realistic	2007, 2008, 2010, 2011, 2012, 2017
RCA	2001, 2002, 2003, 2008, 2010, 2013
Realistic	2007, 2008, 2010, 2011, 2012, 2017
Samsung	2008
Sansui	2006
Sanyo	2007, 2008
Scott	2015
Sears	2007, 2010, 2013
Sharp	2016, 2017
Shintom	2004
Singer	2010
Sony	2004, 2018
STS	2010
Sylvania	2010, 2011, 2012, 2014
Symphonic	2012
Tandy	2007
Teac	2012
Technics	2010
Teknika	2010, 2012
Toshiba	2013, 2015
Totevision	2008
Unitech	2008
Vector Research	2005, 2006
Video Concepts	2005, 2006
Wards	2008, 2010, 2012, 2013, 2017
XR-12000	2010, 2012
Yamaha	2005, 2006, 2007, 2009
Zenith	2004

Using the Remote Controller with Other Components—Continued

TV	
Manufacturer	Control code
Akai	1002
Amtron	1009
Anam National	1003, 1009
AOC	1004, 1005, 1006
Audiovox	1009
Bell & Howell	1010, 1017
Celebrity	1002
Citizen	1004, 1006, 1009, 1017
Colortyme	1004, 1006
Contec/Cony	1007, 1009
Craig	1009
Crown	1009, 1014
Curtis Mathes	1001, 1004, 1006, 1010, 1017
Daewoo	1004, 1005, 1006
Daytron	1004, 1006
Dimensia	1001
Dumont	1004
Electroband	1002
Electrohome	1002, 1003, 1004, 1006, 1008
Emerson	1004, 1006, 1007, 1009, 1010, 1017, 1029
Envision	1004, 1006
Fisher	1010, 1017
Fujitsu	1070
Funai	1009
GE	1001, 1003, 1004, 1006, 1011, 1012
GoldStar	1004, 1005, 1006, 1007, 1008
Hallmark	1004, 1006
Hitachi	1004, 1006, 1007, 1013
Infinity	1014
JBL	1014
JC Penney	1001, 1004, 1005, 1006, 1011, 1012, 1016
Jensen	1004, 1006
JVC	1007, 1012, 1013, 1015
Kawasho	1002, 1004, 1006
Kenwood	1004, 1006, 1008
Kloss Novabeam	1009
KTV	1009
LG	1005
Loewe	1014
Luxman	1004, 1006
LXI	1001, 1006, 1010, 1014, 1016, 1017
Magnavox	1004, 1006, 1008, 1014, 1018
Marantz	1004, 1006, 1014
Megatron	1006
Memorex	1005, 1006, 1010, 1017
MGA	1004, 1005, 1006, 1008
Mitsubishi	1004, 1005, 1006, 1008
Motorola	1003
MTC	1004, 1005, 1006
Multitech	1009
NAD	1006
NEC	1003, 1004, 1005, 1006
Nikko	1006
Onwa	1009
Orion	1029
Panasonic	1003, 1012, 1014
Philco	1003, 1004, 1005, 1006, 1007, 1008, 1014, 1018

TV	
Manufacturer	Control code
Philips	1003, 1004, 1007, 1008, 1014, 1018
Pioneer	1004, 1006
Portland	1004, 1005, 1006
Prism	1012
Proscan	1001
Proton	1004, 1006, 1007
Quasar	1003, 1012
Radio Shack	1010, 1017
Radio Shack/Realistic	1001, 1004, 1006, 1007, 1009, 1010, 1017
RCA	1001, 1003, 1004, 1005, 1006, 1008
Realistic	1010, 1017
Sampo	1004, 1006
Samsung	1004, 1005, 1006, 1007, 1008
Sansui	1029
Sanyo	1004, 1010, 1017
Scott	1004, 1006, 1007, 1009
Sears	1001, 1004, 1006, 1008, 1010, 1015, 1016, 1017
Sharp	1004, 1006, 1007
Sony	1002, 1030, 1032
Soundesign	1004, 1006, 1009
Starlite	1009
Sylvania	1004, 1006, 1008, 1014, 1018
Symphonic	1009
Tatung	1003
Technics	1012
Techwood	1004, 1006, 1012
Teknika	1004, 1005, 1006, 1007, 1009
Toshiba	1010, 1016, 1017
Universal	1011
Wards	1001, 1004, 1005, 1006, 1008, 1011, 1014, 1018
Yamaha	1004, 1005, 1006, 1008
Zenith	1004

Using the Remote Controller with Other Components—Continued

Controlling a Satellite Receiver

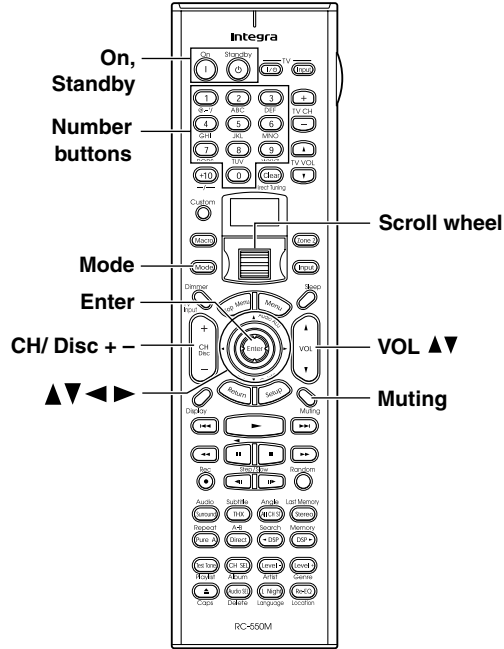

1. Press the [Mode] button, and then roll the scroll wheel to select “SAT.”
2. Point the remote controller at your satellite receiver, and use the following buttons (you must enter appropriate remote control code first).

[On], [Standby]	Set the satellite receiver to On or Standby
[CH/Disc]	Select satellite channels
[▲]/[▼]/[◀]/[▶]	Select menu items
[Enter]	Confirm selection
Number buttons	Enter numbers

The following buttons control the DTR-8.4.

[VOL]	Adjust the DTR-8.4 volume
[Muting]	Mute the DTR-8.4

Controlling a VCR

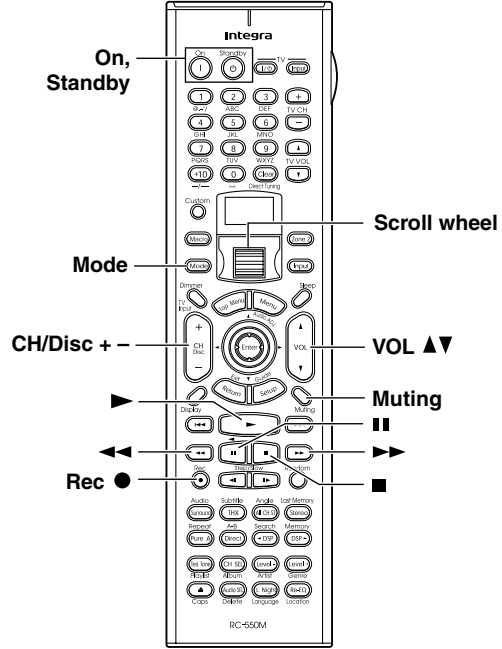

1. Press the [Mode] button, and then roll the scroll wheel to select “VCR.”
2. Point the remote controller at your VCR, and use the following buttons (you must enter appropriate remote control code first).

[On], [Standby]	Set the VCR to On or Standby
[CH/Disc]	Select TV channels
[▶]	Play
[■]	Stop
[◀◀]	Rewind
[▶▶]	Fast forward
[]	Pause
Rec [●]	Record

The following buttons control the DTR-8.4.

[VOL]	Adjust the DTR-8.4 volume
[Muting]	Mute the DTR-8.4

Using the Remote Controller with Other Components—Continued

Controlling a TV

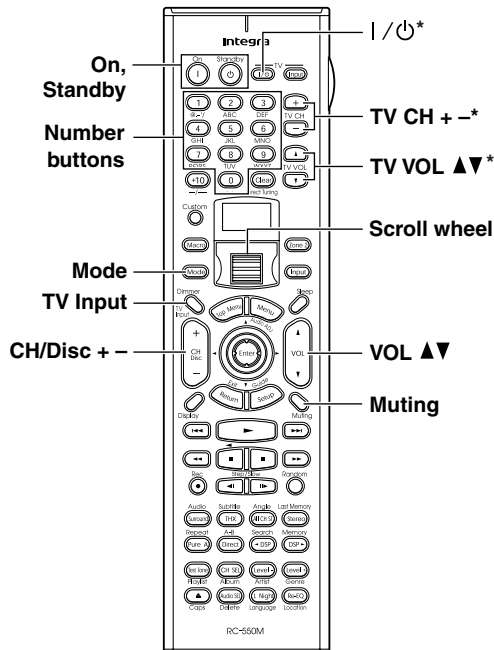

1. Press the [Mode] button, and then roll the scroll wheel to select "TV."
2. Point the remote controller at your TV, and use the following buttons (you must enter appropriate remote control code first).

[On], [Standby]	Set the TV to On or Standby
TV [I/⏻]	TV on/off
TV CH [+]/[-]	Select TV channels
Number buttons	Enter numbers
[CH/Disc]	Select cable channels
[TV Input]	Select TV or VCR input
TV VOL [▲]/[▼]	Adjust the TV volume

*: Buttons marked with an asterisk can always be used to control a TV regardless of the currently selected remote controller mode. These buttons do not work with the additional TV modes.

The following buttons control the DTR-8.4.

[VOL]	Adjust the DTR-8.4 volume
[Muting]	Mute the DTR-8.4

Controlling a Cable Receiver

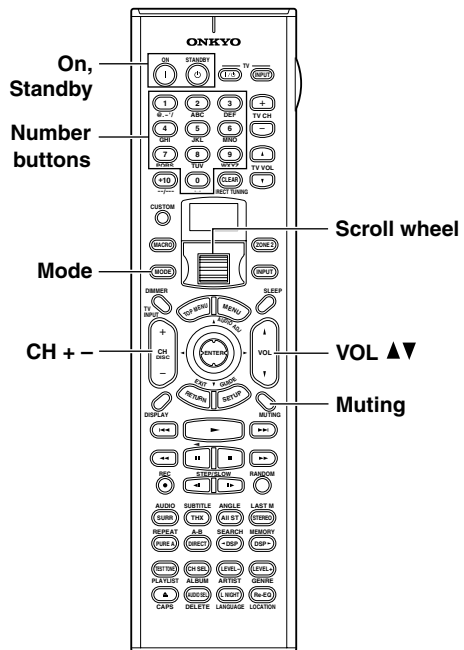

1. Press the [Mode] button, and then roll the scroll wheel to select "CBL."
2. Point the remote controller at your cable receiver, and use the following buttons (you must enter appropriate remote control code first).

[On], [Standby]	Set the cable receiver to On or Standby
[CH/Disc]	Select cable channels
Number buttons	Enter numbers

The following buttons control the DTR-8.4.

[VOL]	Adjust the DTR-8.4 volume
[Muting]	Mute the DTR-8.4



Using the Remote Controller with Other Components—Continued

Learning Commands from Another Remote Controller

You can teach the DTR-8.4's remote controller new commands simply by transmitting commands from another remote controller one at a time. For example, by transmitting the Play and Stop commands from your CD player's remote controller, the DTR-8.4's remote controller can be taught to transmit those commands when its Play [▶] and Stop [■] buttons are pressed in CD mode.

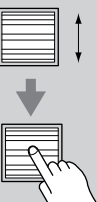
This is convenient when you want to add commands to buttons after entering a remote control code (page 88).

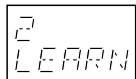
- 1**  **Press and hold the [Custom] button for more than three seconds.**
The remote controller enters Custom mode.
- 2**  **Roll the scroll wheel to select "LEARN," and then press the scroll wheel.**

- 3**  **Roll the scroll wheel to select the remote controller mode you want to teach a new command, and then press the scroll wheel.**
The following remote controller modes can be selected: DVD, TV, VCR, CBL, or SAT.

- 4** **On the DTR-8.4's remote controller, press the button you want to teach the new command.**

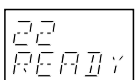

If you press a button that cannot be taught a new command, the message "RETRY" appears and you should press another button.

5

Point the remote controllers at each other, about 2 to 6 inches (5–15 cm) apart, and then, on the other remote controller, press the button whose command you want to learn.

When the command has been learnt successfully, "OK" appears on the display. You may need to press the button several times.

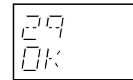

If the command is not learnt successfully, after the message "FAIL" has been displayed, the mode select display reappears (step 3), and you should try again.

6

To teach the DTR-8.4's remote controller more new commands, repeat steps 3 through 5.

Press the [Custom] button when you've finished.

Notes:

- The following buttons cannot be taught new commands: [Light], [Custom], [Macro], [Mode], [Input], [Zone 2], and the scroll wheel button.
- The DTR-8.4's remote controller can learn a total of 150 commands. However, the commands of some remote controllers may use a lot of memory, in which case, this total will be reduced.
- If the message "FULL" appears, the remote controller cannot learn any more commands because its memory is full.
- By default, the DTR-8.4's remote controller knows the commands for controlling an Integra/Onkyo CD player, cassette deck, DVD player, and MD player (e.g., Play, Stop, Pause, etc., buttons). You can teach these buttons new commands, although the defaults will be restored if the remote controller is reset.
- To teach a new command to a button that has already been taught a command, simply repeat this procedure.
- Like most remote controllers, the DTR-8.4's remote controller uses infrared. Commands from remote controllers that don't use infrared cannot be learnt.
- When the remote controller's batteries expire, all learnt commands will be lost and will have to be learnt all over again, so don't discard your other remote controllers.

Using the Remote Controller with Other Components—Continued

Using Macros



With the Macro function you can program the remote controller to perform a sequence of actions with one press of a button. For example, normally you need to perform the following actions to use a CD player that's connected to the DTR-8.4:

1. Press the scroll wheel, (to select AMP mode).
2. Press the [On] button (to turn on the DTR-8.4).
3. Roll the scroll wheel to select CD (to select the CD remote controller mode and the CD input source).
4. Press the Play [▶] button (to start the CD player).

With the Macro function you can program the remote controller to do all of this with one press of a button.

Making Macros

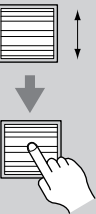
You can make up to eight macros, and each macro can perform up to eight actions.

1  Custom	<p>Press and hold the [Custom] button for more than three seconds. The remote controller enters Custom mode.</p>
2  MACRO	<p>Roll the scroll wheel to select "MACRO," and then press the scroll wheel.</p>
3  301 EDIT	<p>Roll the scroll wheel to select "EDIT," and then press the scroll wheel.</p>

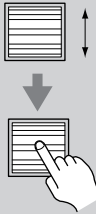
4  301 1 Macro #1 selected 3011 KEY Action #1	<p>Roll the scroll wheel to select a macro, and then press the scroll wheel. Macros are numbered from 1 to 8.</p>
5 3018 SET Macro #1 selected 8 actions learnt	<p>On the remote controller, press the buttons whose actions you want to program into the macro in the order you want them performed. To program the CD example in the left column into a macro: press the scroll wheel, press the [On] button, roll the scroll wheel to select CD, press the scroll wheel, and then press the Play [▶] button. Actions are numbered from 1 to 8.</p>
6 Macro 3019 OK	<p>When you've finished, press the [Macro] button. After the following appears on the display, the display returns to normal.</p>

Using the Remote Controller with Other Components—Continued



Running Macros

Programmed macros can be run as follows.

1	Press the [Macro] button.
2	Roll the scroll wheel to select the macro's number, and then press the scroll wheel. The actions in the macro are performed in the order in which they were programmed.

Naming Macros

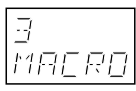
You can name your macros as follows. Names may contain of up to five characters.

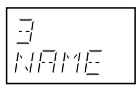
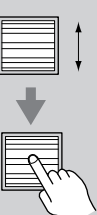
1 	Press and hold the [Custom] button for more than three seconds. The remote controller enters Custom mode. 
2 	Roll the scroll wheel to select "MACRO," and then press the scroll wheel.
3 	Roll the scroll wheel to select "NAME," and then press the scroll wheel. 
4 	Roll the scroll wheel to select the number of the macro that you want to name, and then press the scroll wheel.

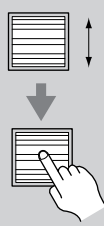
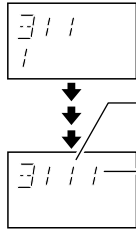
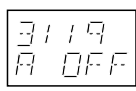



5 	Roll the scroll wheel to select a character, and then press the scroll wheel to set it. The following characters are available. 0 1 2 3 4 5 6 7 8 9 A B C D E F G H I J K L M N O P Q R S T U V W X Y Z + - = < > _ ' / \ * space 
6	Repeat step 5 until you've entered all 5 characters. The previous menu reappears. If the name you are entering consists of less than five characters, enter spaces at the end to make it up to five. 

Using the Remote Controller with Other Components—Continued

Editing Remote Controller Modes

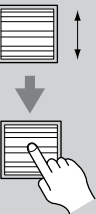
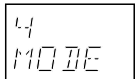
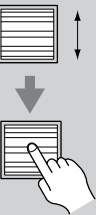
Adding New Remote Controller Modes

You can add additional modes (DVD, TV, VCR, CBL, SAT) to the remote controller. This is useful if, for example, you have several DVD players or TVs.

<p>1 Custom</p> 	<p>Press and hold the [Custom] button for more than three seconds. The remote controller enters Custom mode.</p>
<p>2</p> 	<p>Roll the scroll wheel to select "MODE," and then press the scroll wheel.</p> 
<p>3</p> 	<p>Roll the scroll wheel to select "ADD," and then press the scroll wheel.</p> 
<p>4</p> 	<p>Roll the scroll wheel to select the type of mode you want to add, and then press the scroll wheel.</p>  <p>You can add up to 8 additional modes: 4 DVD, 2 TV, 1 VCR, and 1 CBL.</p>

Reordering the Remote Controller Modes

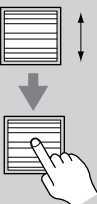
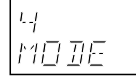
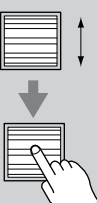
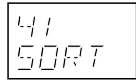
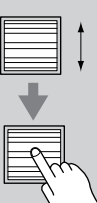
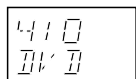
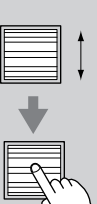
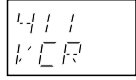
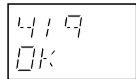

You can change the order in which the remote controller modes appears when you roll the scroll wheel. The position of the AMP mode cannot be changed.

<p>1 Custom</p> 	<p>Press and hold the [Custom] button for more than three seconds. The remote controller enters Custom mode.</p>
<p>2</p> 	<p>Roll the scroll wheel to select "MODE," and then press the scroll wheel.</p> 
<p>3</p> 	<p>Roll the scroll wheel to select "SORT," and then press the scroll wheel.</p> 
<p>4</p> 	<p>Roll the scroll wheel to select the mode you want to move, and then press the scroll wheel.</p> 
<p>5</p> 	<p>Roll the scroll wheel to select the mode before which you want to insert the specified mode, and then press the scroll wheel. Here the specified mode will be inserted before the "VCR" mode.</p>  <p>If the move is successful, after "OK" has been displayed, the SORT display (step 3) reappears.</p> 

Using the Remote Controller with Other Components—Continued



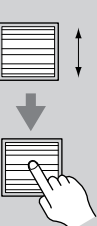
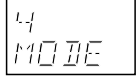

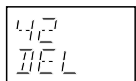
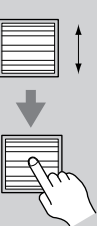
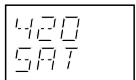
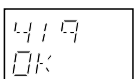
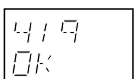

Deleting Remote Controller Modes

You can delete remote controller modes that you don't need, such as modes for components that you don't have. The AMP mode cannot be deleted.

1 	Press and hold the [Custom] button for more than three seconds. The remote controller enters Custom mode.
2 	Roll the scroll wheel to select "MODE," and then press the scroll wheel. 
3 	Roll the scroll wheel to select "DEL," and then press the scroll wheel. 
4 	Roll the scroll wheel to select the mode you want to delete, and then press the scroll wheel.  If the mode is deleted successfully, after "OK" has been displayed, the DEL display (step 3) reappears.  

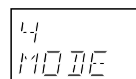
Assigning Remote Controller Modes

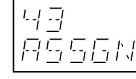
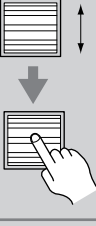
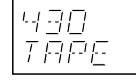
With this function you can assign a remote controller mode to an input source. This is useful when you connect, say, a CD recorder to the TAPE IN/OUT sockets. By assigning the CDR remote controller mode to the TAPE input source, you can use the remote controller to control the CD recorder.

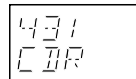
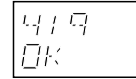
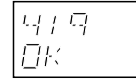



1 	Press and hold the [Custom] button for more than three seconds. The remote controller enters Custom mode.
2 	Roll the scroll wheel to select "MODE," and then press the scroll wheel. 
3 	Roll the scroll wheel to select "ASSIGN," and then press the scroll wheel. 
4 	Roll the scroll wheel to select an input source, and then press the scroll wheel. 
5 	Roll the scroll wheel to select the mode you want to assign to the specified input source, and then press the scroll wheel.  If the assignment is successful, after "OK" has been displayed, the ASSIGN display (step 3) reappears.  

Using the Remote Controller with Other Components—Continued

Changing the Remote Controller's Transmission Signal Format (IR/RF)

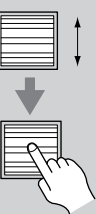
You can set the remote controller's transmission signal format to either infrared (IR) or radio frequency (RF). The default setting is IR.

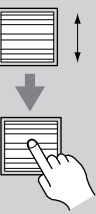
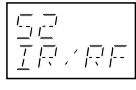
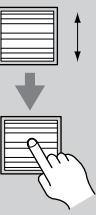
This is useful when, for example, the DTR-8.4 is installed in a rack or is not in line of sight of the remote controller as it allows you to use a commercially available RF receiver to pick up commands from the remote controller, which are then fed to the DTR-8.4 via its IR IN socket. For this to work, you must assign the same ID and channel to the remote controller and RF receiver.

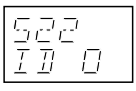
1 	<p>Press and hold the [Custom] button for more than three seconds. The remote controller enters Custom mode.</p>
2 	<p>Roll the scroll wheel to select "SETUP," and then press the scroll wheel.</p> 
3 	<p>Roll the scroll wheel to select "IR/RF," and then press the scroll wheel.</p> 
4 	<p>Roll the scroll wheel to select "IR" or "RF," and then press the scroll wheel. When you select "IR."</p> 
5 	<p>If you select "RF," roll the scroll wheel to select the same ID as the RF receiver, and then press the scroll wheel. IDs 0 to 9 and A to F can be selected.</p> 

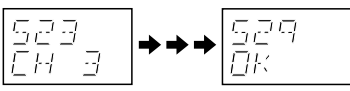
6 	<p>Roll the scroll wheel to select the same channel as the RF receiver, and then press the scroll wheel. Channels 0 to 3 can be selected. If the ID and channel have been set successfully, "OK" appears on the display.</p> 
---	--

Resetting the Remote Controller

You can reset the remote controller to its default settings.

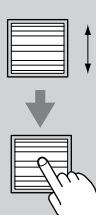
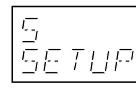
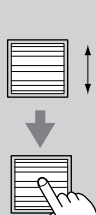
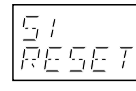
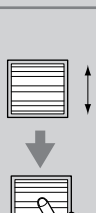
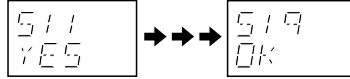
1 	<p>Press and hold the [Custom] button for more than three seconds. The remote controller enters Custom mode.</p>
2 	<p>Roll the scroll wheel to select "MODE," and then press the scroll wheel.</p> 
3 	<p>Roll the scroll wheel to select "RESET," and then press the scroll wheel.</p> 
4 	<p>Roll the scroll wheel to select "YES," and then press the scroll wheel. The remote controller is reset to its default settings.</p> 

Troubleshooting

If you have any trouble using your DTR-8.4, look for a solution in this section. If you can't resolve the issue yourself, contact your Integra/Onkyo dealer.

Power

Can't turn on the DTR-8.4?

- Make sure that the power cord is properly plugged into the wall outlet. Make sure that the other end of the power cord is properly connected to the DTR-8.4's AC INLET.
- Unplug the power cord from the wall outlet, wait five seconds or more, then plug the cable in again.

The DTR-8.4 turns off as soon as it's turned on?

- The amp protection circuit has been activated. Remove the power cord from the wall outlet immediately and contact your Integra/Onkyo dealer.

Audio

There's no sound, or it's very quiet?

- Make sure that all audio connecting plugs are pushed in all the way (page 26).
- Make sure that the inputs and outputs of all components are connected properly (page 26).
- Make sure that the polarity of the speaker cables is correct and that the bare wires are in contact with metal part of each speaker terminal (page 23)
- Make sure that the input source is properly selected (page 51).
- Check the volume. It can be set from 0 to 100 (page 51).
The DTR-8.4 is designed for home theater enjoyment. It has a wide volume range, allowing precise adjustment.
- If the MUTING indicator is shown on the display, press the remote controller's [Muting] button to unmute the DTR-8.4 (page 52).
- While a pair of headphones is connected to the PHONES jack, no sound is output by the speakers (page 52).
- Check the digital audio output setting on the connected device. On some games consoles, such as those that support DVD, the default setting is off.
- With some DVD-Video discs, you need to select an audio output format from a menu.
- Make sure that the correct input signal audio format is selected with the [Audio Selector] button (page 53).
- To use a turntable with an MC-type cartridge requires a commercially available MC phono preamp (page 35).
- Make sure that none of the connecting cables are bent, twisted, or damaged.
- Not all listening modes use all of the speakers (page 56).
- Specify the speaker distances (page 43) and adjust the individual speaker levels (page 44).

Only the front speakers produce sound?

- When the Stereo listening mode is selected, only the front speakers and subwoofer produce sound.
- When the Direct or Pure Audio listening mode is selected, only the front speakers produce sound.
- Make sure the speakers are configured correctly (page 41).

Only the center speaker produces sound?

- If you use the Pro Logic II Movie or Pro Logic II Music listening mode with a mono source, such as an AM radio station or mono TV program, the sound is concentrated in the center speaker.
- Make sure the speakers are configured correctly (page 41).

The surround speakers produce no sound?

- When the Stereo, Direct, or Pure Audio listening mode is selected, the surround speakers produce no sound (page 56).
- Depending on the source and current listening mode, not much sound may be produced by the surround speakers. Try selecting another listening mode.
- Make sure the speakers are configured correctly (page 41).

The center speaker produces no sound?

- When the Mono, Stereo, Direct, or Pure Audio listening mode is selected, the center speaker produces no sound (page 56).
- When the Orchestra listening mode is selected, the center speaker produces no sound (page 57).
- Make sure the speakers are configured correctly (page 41).

The surround back speakers produce no sound?

- The surround back speakers are not used with all listening modes. Select another listening mode (page 56).
- Not much sound may be produced by the surround back speakers with some sources.
- If you are using the Dolby Digital EX or THX Surround EX listening mode, make sure that mode is set to On (see "Using the Digital Surround Modes" on page 60).
- Make sure the speakers are configured correctly (page 41).

The subwoofer produces no sound?

- When you play source material that contains no information in the LFE channel, the subwoofer produces no sound.
- Make sure the speakers are configured correctly (page 41).

Troubleshooting—Continued

There's no sound with a certain signal format?

- Check the input signal format setting. Depending on the playback source, you can select Auto, Multich, Analog, DTS, or PCM (page 53).
- Check the digital audio output setting on the connected device. On some games consoles, such as those that support DVD, the default setting is off.
- With some DVD-Video discs, you need to select an audio output format from a menu.
- Depending on the input signal, some listening modes cannot be selected (page 58).

Can't select the DTS-ES Discrete/Matrix or THX Surround EX listening modes?

- These modes cannot be selected when no surround back speakers are connected, or Zone 2 is being used.

Can't get 6.1 or 7.1 playback?

- If no surround back speakers are connected, or Zone 2 is being used, 6.1 and 7.1 playback is not possible.

The volume cannot be set above 99?

- When the levels of all speakers have been calibrated (page 44), the maximum volume setting may change.

Noise can be heard?

- Using cable ties to bundle audio cables with power cords, speaker cables, and so on may degrade the audio performance, so don't do it.
- An audio cable may be picking up interference. Try repositioning your cables.

The Late Night function doesn't work?

- Make sure the source material is Dolby Digital (page 62).

The multichannel input doesn't work?

- Check the MULTI CH INPUT connections (page 29).
- Make sure that the multichannel input is assigned to the correct input source (page 63).
- Set the audio input signal format to Multich (page 53).

About DTS signals

- When DTS program material ends and the DTS bit-stream stops, the DTR-8.4 remains in DTS listening mode and the DTS indicator remains on. This is to prevent noise when you use the pause, fast forward, or fast reverse function on your player. If you switch your player from DTS to PCM, because the DTR-8.4 does not switch formats immediately, you may not hear any sound, in which case you should stop your player for about three seconds, and then resume playback.
- With some CD and LD players, you won't be able to playback DTS material properly even though your player is connected to a digital input on the DTR-8.4. This is usually because the DTS bitstream has been processed (e.g., output level, sampling rate, or frequency response changed) and the DTR-8.4 doesn't recognize it as a genuine DTS signal. In such cases, you may hear noise.
- When playing DTS program material, using the pause, fast forward, or fast reverse function on your player

may produce a short audible noise. This is not a malfunction.

Video

There's no picture?

- Make sure that all video connecting plugs are pushed in all the way (page 26).
- Make sure that each video component is properly connected.
- If your video component is connected to a component video input, your TV must be connected to the component video output, unless the Component Video setting is set to VIDEO (page 47).
- On your TV, make sure that the video input to which the DTR-8.4 is connected is selected.
- While the Pure Audio listening mode is selected, the video circuits are turned off and the DTR-8.4 outputs no video signals.

The onscreen menus (OSD) don't appear, or they appear in an odd position?

- Make sure that the video settings are correct (page 46).
- Check the Display Position and OSD Position settings (page 73).
- On your TV, make sure that the video input to which the DTR-8.4 is connected is selected.

Tuner

Reception is noisy, FM stereo reception is noisy, or the FM STEREO indicator doesn't appear?

- Relocate your antenna.
- Move the DTR-8.4 away from your TV or computer.
- Try using the AUTO FM mode (page 54).
- When listening to an AM station, operating the remote controller may cause noise.
- Passing cars and airplanes can cause interference.
- Concrete walls weaken radio signals.
- If nothing improves the reception, install an outdoor antenna.

Remote Controller

The remote controller doesn't work?

- Make sure that the batteries are installed with the correct polarity (page 8).
- Install new batteries. Don't mix different types of batteries or old and new batteries (page 8).
- Make sure that the remote controller is not too far away from the DTR-8.4, and that there's no obstruction between the remote controller and the DTR-8.4's remote control sensor (page 8).

Troubleshooting—Continued

- Make sure that the DTR-8.4 is not subjected to direct sunshine or inverter-type fluorescent lights. Relocate if necessary.
- If the DTR-8.4 is installed in a rack or cabinet with colored-glass doors, the remote controller may not work reliably when the doors are closed.
- Make sure you've selected the correct remote controller mode (page 14).
- When using the remote controller to control other manufacturers' AV components, some buttons may not work as expected.
- Make sure you've entered the correct remote control code.
- If you change the remote controller's transmission signal format to RF, be sure to select the same ID as the RF receiver.

Can't control other components?

- If it's an Integra/Onkyo component, make sure that the **RI** cable and analog audio cable (RCA/phono) are connected properly. Connecting only an **RI** cable won't work (page 36).
- Make sure you've selected the correct remote controller mode (page 14).
- If you connect an MD recorder to the TAPE sockets, be sure to set make the necessary setting (page 50).

Can't learn commands from other remote controllers?

- Make sure that the transmitting ends of both remote controllers are pointing at each other.
- Are you trying to learn from a remote controller that cannot be used for learning? Some commands cannot be learnt, especially those that transmit several instructions with a single button press.

Recording

Can't record?

- On your recorder, make sure the correct input is selected (e.g., digital or analog).

Zone 2

Zone 2 has turned off?

- Was the Sleep function set? The Sleep function turns off Zone 2 as well as the DTR-8.4. To set the Sleep function for Zone 2 only, see page 87.

There's no sound?

- Since the Zone 2 function and the REC OUT outputs use the same circuitry, you cannot use Zone 2 and record at the same time. When the [Rec Out] button is pressed, Zone 2 is turned off.

The Surr Back speaker setting doesn't appear?

- If no surround back speakers are connected, or the surround back outputs are being used with Zone 2, this setting is unavailable.

Net-Tune

Can't access Internet radio or the network audio server?

- Check the connection between the DTR-8.4 and the LAN port on your router or switch.
- Make sure that your modem and router are properly connected, and make sure they are both turned on.
- Make sure that the Network Setup settings are correct (page 82).

Playback stops while listening to Net-Tune tracks?

- Make sure that your Net-Tune system meets the system requirements listed on page 75.
- If network audio server is serving WAV files to several clients at the same time, the network may become overloaded and playback may be interrupted. This can be resolved by preparing an Ethernet network exclusively for use with Net-Tune, separating it from general network traffic, and by using switches to improve network performance.

Can't get a list of Internet radio stations from the Xiva-Net online database?

- Try again later.

Can't access music on the selected server, or can't connect to the server?

- Make sure that your network audio server is turned on.
- Add the MP3 and WAV files on your network audio server database.
- On the 5-4. Client Setup menu, make sure that the NTSP Port setting is set to the same port number as network audio server. Correct as necessary (page 83).

Can't select albums?

- Use network audio server to add album names to your music files.

Can't select artists?

- Use network audio server to add artist names to your music files.

Can't select by genre?

- Use network audio server to add genre names to your music files.

No playlists are available?

- Use network audio server to create some playlists.

For other Net-Tune-related issues, please see the Net-Tune FAQ on the Integra/Onkyo Web site.

Troubleshooting—Continued

Others

The sound changes when I connect my headphones?

- When a pair of headphones is connected, the listening mode is set to Stereo, unless it's already set to Stereo, Direct, or Pure Audio. When you disconnect the headphones, the previous listening mode is resumed.

Can't change a setting?

- Not all settings appear on the Basic menu. Select the Advance menu.
- Some settings are not available while using Net-Tune.

Can't use an audio adjust function?

- Some audio adjust functions can't be used with certain listening modes.

The speaker distance cannot be set as required?

- If the distance between the furthest and nearest speakers is greater than 20 feet (6 meters), corrected values suitable for home theater use will be set automatically (page 43).

The display doesn't work?

- The display is turned off when the Pure Audio listening mode is selected.
- While a video signal from a video component is being output, actions are not displayed onscreen.

"0. Hardware Setup" does not appear in the menu?

- Once you've configured the Hardware Setup settings, "0. Hardware Setup" no longer appears in the Basic menu. Select the Advanced menu to access these settings (page 39).

Error Messages

"Not available With Headphones Use"

- Operation not allowed while a pair of headphones is connected.

"Not available With Multichannel Use"

- Operation not allowed while the multichannel input is being used.

"Not available In This Sp Config"

- Doesn't work with the current speaker configuration.

"Not available in Zone 2 Mode"

- This setting cannot be changed while Zone 2 is being used.

"Only available With Dolby D"

- Can be used with only Dolby Digital.

"Not available with this signal"

- Doesn't work with the current listening mode.

"Not available in Pure Audio mode"

- Operation not allowed while the Pure Audio listening mode is selected.

"Surr Back/Zone 2 setting is Surr Back"

- Operation not allowed because the Surr Back/Zone 2 setting on the 0-2 Surr Back/Zone 2 menu is set to Surr Back.

"Surr Back/Zone 2 setting is Zone 2"

- Operation not allowed because the Surr Back/Zone 2 setting on the 0-2 Surr Back/Zone 2 menu is set to Zone 2.

"Not available with the Surr Back/Zone 2 setting"

- Operation not allowed with the current Surr Back/Zone 2 setting on the 0-2 Surr Back/Zone 2 menu.

"Not available with Muting"

- Operation not allowed because the DTR-8.4 is currently muted.

"Zone 2 is not On"

- Operation not allowed because Zone 2 is off.

The DTR-8.4 contains a microcomputer for signal processing and control functions. In very rare situations, severe interference, noise from an external source, or static electricity may cause it to lockup. In the unlikely event that this happens, unplug the power cord from the wall outlet, wait at least five seconds, and then plug it back in again.

To reset the DTR-8.4 to its factory defaults, turn it on and, while holding down the [Video 1] button, press the [Standby/On] button. When the reset is complete, "CLEAR" appears on the display and the DTR-8.4 enters Standby mode.

Onkyo is not responsible for damages (such as CD rental fees) due to unsuccessful recordings caused by the unit's malfunction. Before you record important data, make sure that the material will be recorded correctly.

Specifications

Amplifier Section

Power output: All channels:	110 W (8 Ω, 20 Hz–20 kHz, FTC) (American Model) 150 W (6 Ω, 1 kHz, DIN) (Australian model)
Dynamic power:	2 x 280 W (3 Ω, front) 2 x 220 W (4 Ω, front) 2 x 140 W (8 Ω, front)
THD (total harmonic distortion):	0.08% (rated power)
Damping factor:	60 (8 Ω)
Input sensitivity and impedance:	200 mV/50k Ω (LINE) 2.5 mV/50k Ω (PHONO MM)
Output level and impedance:	200 mV/470 Ω (REC OUT)
Phono overload:	120 mV (MM, 1 kHz, 0.5%)
Frequency response:	5 Hz–100 kHz/+1 dB, –3 dB (CD, Direct)
Tone control:	±10 dB, 50 Hz (BASS) ±10 dB, 20,000 Hz (TREBLE)
S/N ratio (Direct mode):	110 dB (LINE, IHF-A, 0.5 V input) 80 dB (PHONO, IHF-A, 5 mV input)
Speaker impedance:	4–16 Ω

Video Section

Input sensitivity, output level and impedance:	1.0 Vp-p/75 Ω (component and S-Video Y) 0.7 Vp-p/75 Ω (component Pb/Cb, Pr/Cr) 0.286 Vp-p/75 Ω (S-Video C) 1.0 Vp-p/75 Ω (composite)
Component video frequency response:	5 Hz–50 MHz

Tuner Section

FM

Tuning frequency range:	87.5–108.0 MHz
Usable sensitivity:	FM STEREO 17.2 dBf, 2.0 μV (75 Ω IHF) FM MONO 11.2 dBf, 1.0 μV (75 Ω IHF)
S/N ratio:	FM STEREO 70 dB (IHF-A) FM MONO 76 dB (IHF-A)
THD:	FM STEREO 0.3% FM MONO 0.2%
FM stereo separation:	45 dB at 1 kHz, 30 dB at 100 Hz–10 kHz

AM

Tuning frequency range:	530–1710 kHz (American model) 522–1611 kHz (Australian model)
Usable sensitivity:	30 μV
S/N ratio:	40 dB
THD:	0.7%

General

Power supply:	American model: AC 120 V, 60 Hz Australian model: AC 230–240 V, 50 Hz
Power consumption:	American model: 9.0 A Australian model: 670 W
Standby power consumption:	2.5 W
Dimensions (W x H x D):	17-1/8" x 6-7/8" x 18-1/8" (435 x 175 x 460 mm)
Weight:	40.8 lbs. (18.5 kg)

Video Inputs

Component video inputs:	2 (Input 1, Input 2)
S-Video inputs:	6 (DVD, Video 1–5)
Video inputs:	6 (DVD, Video 1–5)

Video Outputs

Component video outputs:	1 (Component Monitor Out)
S-Video outputs:	3 (Video 1 Out, Video 2 Out, Video Monitor Out)
Video outputs:	4 (Video 1 Out, Video 2 Out, Video Monitor Out, Zone 2 Video Out)

Audio Inputs

Digital inputs:	8 (Optical 1–4, Optical Video 5 (fixed, on front panel), Coaxial 1–3)
Analog inputs:	9 (CD, Phono, Tape, DVD, Video 1–4, Video 5)
Multichannel analog inputs:	7.1 ch (Front L/R, Center, Surround L/R, Surround Back L/R, Subwoofer)

Audio Outputs

Digital outputs:	2 optical
Analog outputs:	4 (Tape Out, Video 1 Out, Video 2 Out, Zone 2 Out)
Pre outs:	8 (Front L/R, Center, Surround L/R, Surround Back L/R or Zone 2 L/R, Subwoofer)
Subwoofer pre out:	1
Speaker outputs:	7
Phones:	1

Other Sockets

RS-232:	1
IR in/out:	1
12V trigger out:	3
Ethernet (Net-Tune)	1 (10Base-T, RJ45)

Specifications and features are subject to change without notice.

Integra Division of
ONKYO U.S.A. CORPORATION
18 park Way, Upper Saddle River, N.J. 07458, U.S.A.
Tel: 201-785-2600 Fax: 201-785-2650 <http://www.integrahometheater.com>

Integra Division of
ONKYO CORPORATION
Sales & Product Planning Div.: 2-1, Nisshin-cho, Neyagawa-shi, OSAKA 572-8540, JAPAN
Tel: 072-831-8023 Fax: 072-831-8124

SN 29343578
(C) Copyright 2003 ONKYO CORPORATION Japan. All rights reserved.



I0310-1

Integra

DTR-8.4

Quick Guide

- This guide shows you how to connect your speakers and DVD player and enjoy 7.1 surround sound.
- For full details on using the DTR-8.4, refer to the main instruction manual.

Enjoying Home Theater

Front left and right speakers

These output the overall sound. Their role in a home theater is to provide a solid anchor for the sound image. They should be positioned facing the listener at about ear level, and equidistant from the TV. Angle them inward so as to create a triangle, with the listener at the apex.

Center speaker

This speaker enhances the front left and right speakers, making sound movements distinct and providing a full sound image. In movies it's used mainly for dialog. Position it close to your TV (preferably on top) facing forward at about ear level, or at the same height as the front left and right speakers.

Surround back speakers

These speakers further enhance the realism of surround sound and improve sound localization behind the listener. Position them behind the listener about 3 feet (100 cm) above ear level.

Subwoofer

The subwoofer handles the bass sounds of the LFE (Low-Frequency Effects) channel. Position it in a corner or one-third of the way along the front wall.

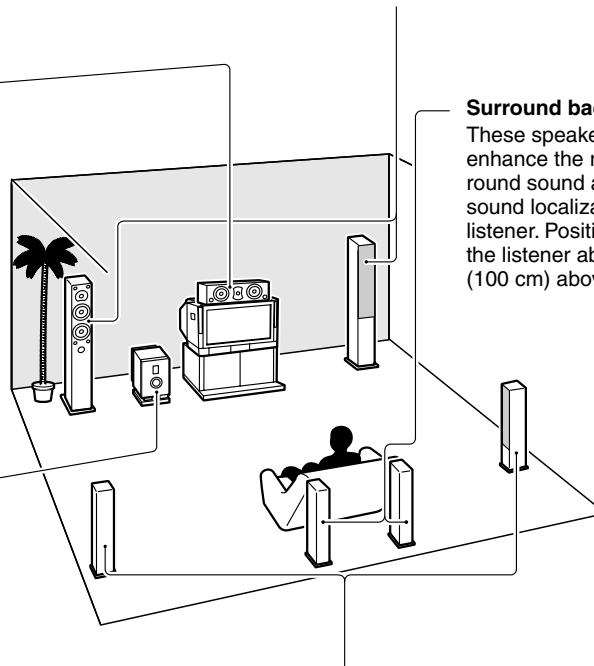

Surround left and right speakers

These speakers are used for precise sound positioning and to add realistic ambience. Position them at the sides of the listener, or slightly behind, about 3 feet (100 cm) above ear level. Ideally they should be equidistant from the listener.

Connecting Your Speakers

Attaching the Speaker Labels





The DTR-8.4's positive (+) speaker terminals are color-coded for ease of identification. (The negative (-) speaker terminals are all black.)

Speaker terminal	Color
Front left	White
Front right	Red
Center	Green
Surround left	Blue
Surround right	Gray
Surround back/Zone 2 left	Brown
Surround back/Zone 2 right	Tan

The supplied speaker labels are also color-coded and you should attach them to the positive (+) side of each speaker cable in accordance with the above table. All you need to do then is to match the color of each label to the corresponding speaker terminal.

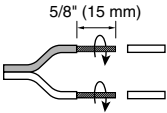

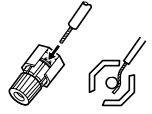
Connecting the Speaker Cables

- 1 Strip about 5/8" (15 mm) of insulation from the ends of the speaker cables, and twist the bare wires tightly, as shown.**

- 2 Unscrew the terminal.**

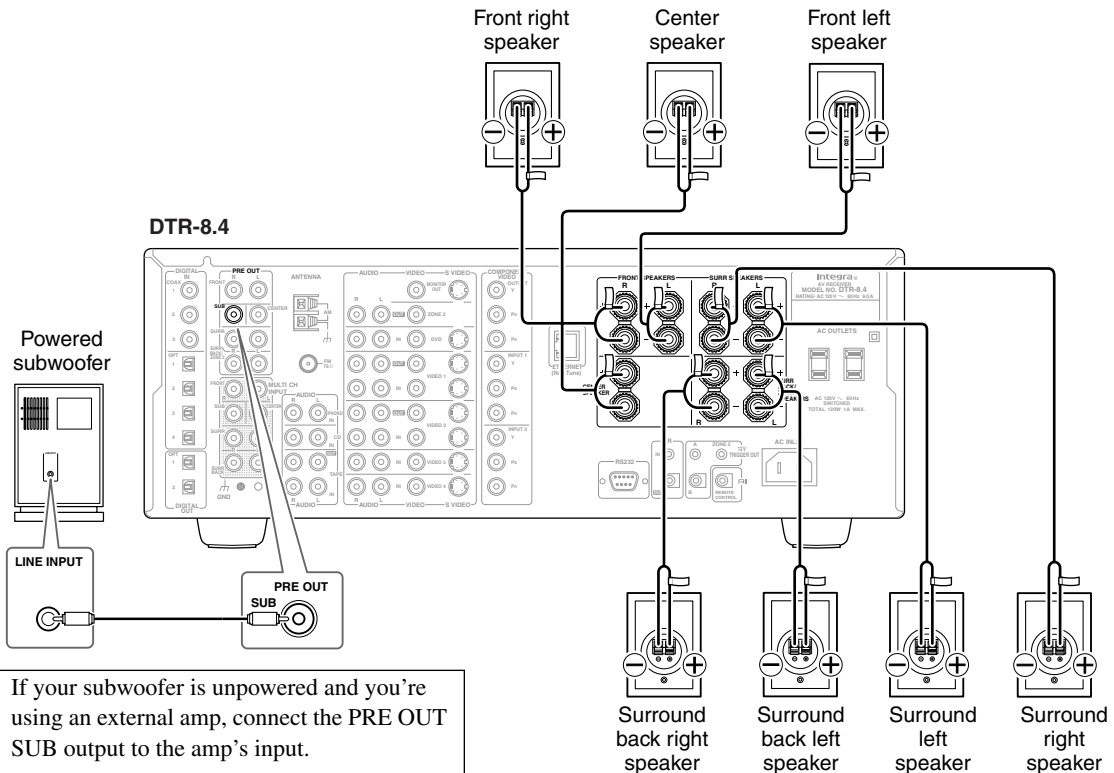
- 3 Fully insert the bare wires.**

- 4 Screw the terminal tight.**

The following illustration shows which speaker should be connected to each pair of terminals.



Connecting Your TV & DVD Player

Connecting a TV

Use a composite video cable to connect the DTR-8.4's VIDEO MONITOR OUT output to a composite video input on your TV.

OR

Use an S-Video cable to connect the DTR-8.4's S VIDEO MONITOR OUT output to an S-Video input on your TV.

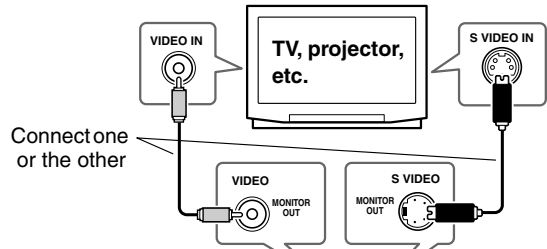

Connecting a DVD Player

■ Using Optical or Coaxial Connections

Use a coaxial digital audio cable to connect the DTR-8.4's DIGITAL IN COAX 1 to the coaxial output on your DVD player, as shown.

OR

Use an optical digital audio cable to connect the DTR-8.4's DIGITAL IN OPT 1, 2, 3, or 4 to the optical output on your DVD player, as shown.

Initially, the COAX1 digital input is assigned to the DVD input source. If you connect your DVD player to a different digital input, you'll need to reassign the DVD input source (see page 45 of the instruction manual).

■ Using Composite Video or S-Video

Use a composite video cable to connect the DTR-8.4's VIDEO DVD IN to the composite video output on your DVD player, as shown.

OR

Use an S-Video cable to connect the DTR-8.4's S VIDEO DVD IN to the S-Video output on your DVD player, as shown.

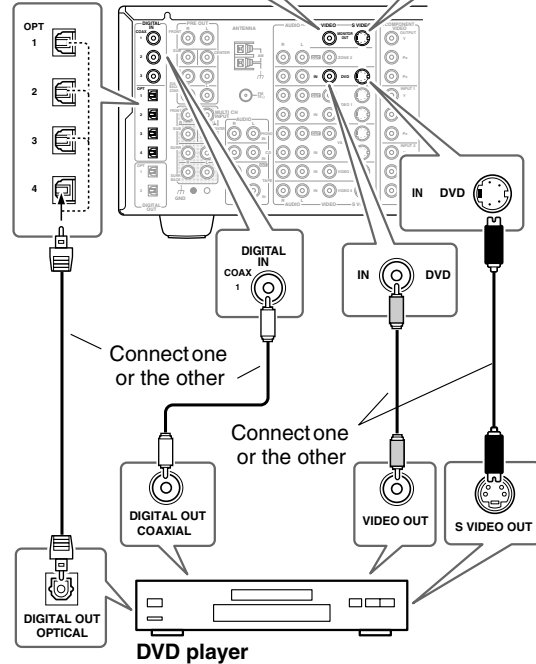

Turning On the DTR-8.4

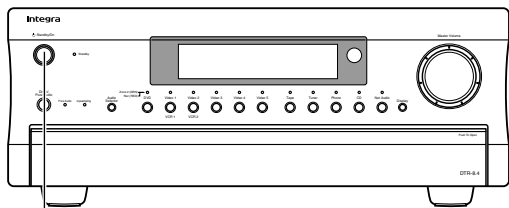

1. Connect the power cord.
2. Press the [Standby/On] button to turn on the DTR-8.4.

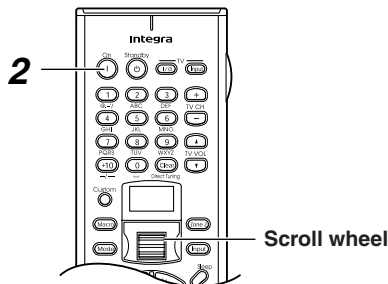

Using the remote controller

1. Press the scroll wheel.
"AMP" appears on the remote controller's display.
This is the mode for controlling the DTR-8.4.
2. Press the [On] button to turn on the DTR-8.4.

Playing a DVD

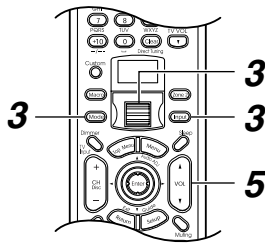

- 1. Turn on your DVD player and TV.**
- 2. Select the appropriate input on your TV.**
Select the input to which the DTR-8.4 is connected.
- 3. Select the DVD input source.**
Roll the scroll wheel to select the DVD input source.

While neither the [Mode] button nor [Input] button is illuminated, rolling the scroll wheel changes the input source and remote controller mode.

4. Start playback on your DVD player.

Make sure that your DVD player's digital audio output is turned on. On some players, the default setting is off. With some DVD-Video discs, you can select the audio format (Dolby Digital, DTS, PCM) from a menu.

5. Adjust the volume.

To adjust the volume, use the remote controller's [VOL] button.

The volume can be adjusted from 0 to 100. Since the DTR-8.4 has been designed for home theater enjoyment, it has a wide volume range, allowing precise adjustment.

Selecting Listening Modes

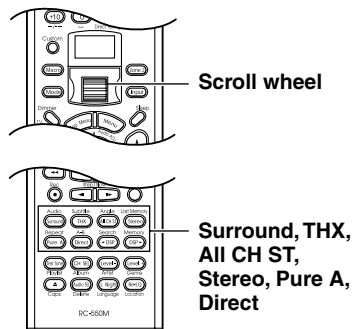

Press the scroll wheel, and then use the [Surround], [THX], [All CH ST], [Stereo], [Pure A], [Direct], or DSP [◀]/[▶] buttons to select a listening mode.

Notes:

- You cannot select any listening modes while the Multich input source is selected.
- Depending on the number of speakers that you connect, and the format of the input signal, you may not be able to select all of the listening modes.
- While the Pure Audio listening mode is selected, the video circuits are turned off and the DTR-8.4 outputs no video signals.

■ [Pure A] button (remote controller)

This button selects the Pure Audio listening mode.

■ [Direct] button (remote controller)

This button selects the Direct listening mode.

■ [Direct/Pure Audio] button (DTR-8.4)

This button selects the Direct and Pure Audio listening modes.

■ [Stereo] button

This button selects the Stereo listening mode.

■ [Surround] button

This button selects the following listening modes for use with 2-channel analog input sources: Dolby Pro Logic II Movie, Dolby Pro Logic II Music, DTS Neo:6 Cinema, and DTS Neo:6 Music.

If the current input source is digital, you can select Dolby Digital, Dolby Digital EX, DTS, DTS-ES, or DTS Neo: 6 with this button.

■ [THX] button

This button selects the THX listening modes. With 2-channel input sources, THX can be applied to Dolby Pro Logic II Movie or DTS Neo:6 Cinema.

The THX listening modes can be selected if the current input source is either analog or digital. If it's digital, you can use this button to apply THX to DTS or DTS-ES.

■ DSP [◀]/[▶] buttons

These buttons are used to select Integra's own DSP listening modes—Orchestra, Unplugged, Studio Mix, etc., and Mono or Theater-Dimensional.

■ [All CH ST] button (remote controller)

This button selects the All Ch Stereo listening mode.

DTR-8.4/7.4 Net-Tune Quick Start Guide

Integra

- This guide explains how to get started quickly with Net-Tune.
- The DTR-8.4/7.4 can be used as a Net-Tune client on a standard Ethernet network, allowing you to play the music (MP3, WAV) stored on your network audio server through the DTR-8.4/7.4. If your network is connected to the Internet, you can also tune into Internet radio stations.
- For full details on using Net-Tune, refer to the DTR-8.4/7.4's instruction manual.

Networking the DTR-8.4/7.4

- For best results, a 100Base-TX switched Ethernet network is recommended. Although it's theoretically possible to use a wireless network, due to unpredictable performance, it may not provide satisfactory results, so a wired network is recommended.
- The DTR-8.4/7.4 uses DHCP to configure its network settings automatically. Make sure that your router's DHCP server is enabled.
- Some routers have a modem built-in, and some ISPs require you to use specific routers. Please consult your ISP or computer dealer if you're unsure.
- You may need to specify a proxy server to use Internet radio. If your network audio server is configured to use a proxy server, use the same settings.
- To use Internet radio, your broadband Internet connection needs to be up and running and able to access the Web. A narrowband Internet connection (e.g., 56K modem, ISDN) will not provide satisfactory results, so a broadband connection is recommended (e.g., cable modem, xDSL modem, etc).

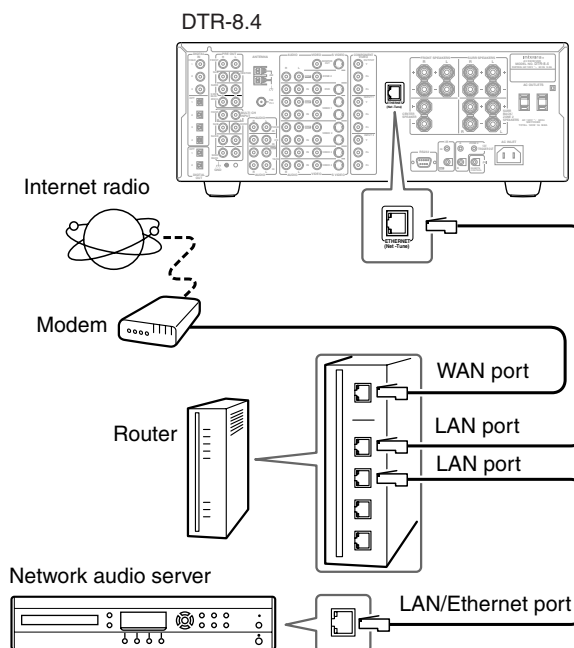

Using Internet Radio

1. **Connect the DTR-8.4/7.4 to your Ethernet network via a router or switch, as shown above.**
2. **Turn on the DTR-8.4/7.4.**
3. **Roll the scroll wheel to select IRD (Internet Radio).**
4. **Press the remote controller's [Display] button.**
5. **Use the Up/Down [▲]/[▼] buttons to select Genres, Location, or Language, and then press the [Enter] button.**
The DTR-8.4/7.4 accesses the XiVA-Net online database to see what radio stations are available. This may take awhile.
6. **Use the Up/Down [▲]/[▼] and [Enter] buttons to select a radio station.**
The DTR-8.4/7.4 connects to the selected radio station and begins buffering audio data, the progress of which is displayed in percent. When buffering reaches 100%, playback starts.

Playing Tracks in the Network Audio Server

1. **Turn on the network audio server.**
2. **Turn on the DTR-8.4/7.4.**
3. **Roll the scroll wheel to select MSRV (Music Server).**
4. **Press the Play [▶] button to start playback.**

Free Manuals Download Website

<http://myh66.com>

<http://usermanuals.us>

<http://www.somanuals.com>

<http://www.4manuals.cc>

<http://www.manual-lib.com>

<http://www.404manual.com>

<http://www.luxmanual.com>

<http://aubethermostatmanual.com>

Golf course search by state

<http://golfingnear.com>

Email search by domain

<http://emailbydomain.com>

Auto manuals search

<http://auto.somanuals.com>

TV manuals search

<http://tv.somanuals.com>