



EtherExpress™ PRO/100 CardBus Mobile Adapter

User's Guide

How to Use This Manual

This User's Guide contains the latest and most complete information available at press time on the installation and operation of the PRO/100 CardBus adapter. It is designed to help both new and experienced network users install and configure the Intel product in the shortest time possible.

Overview of the Installation Process

For an overview of the installation process, see the *Late Breaking News* card and **Chapters 1** and **2** in this User's Guide. For technical details on configuration issues see **Chapter 3, Configuration Reference**.

How to Find More Information

Use the Table of Contents, Index, and page and text headings in this User's Guide to help you find what you need. Check the README file on the Network Drivers diskette. To check for updated drivers, access the Intel website at:

<http://support.intel.com>

See **Appendix A** for additional support information.

Copyright © 1997 Intel Corporation. All rights reserved.

Intel Corporation
5200 N.E. Elam Young Parkway
Hillsboro, OR 97124-6497

Intel Corporation assumes no responsibility for errors or omissions in this guide. Nor does Intel make any commitment to update the information contained herein.

* Other product and corporate names may be trademarks of other companies and are used only for explanation and to the owners' benefit, without intent to infringe.

Second edition

June 1997

668559-002

Contents

Hardware Installation	1
Before Installing Hardware	1
Installing the Hardware	3
What to Do Next	5
Software Installation	7
CardBus Installation Guidelines	7
Installing with Windows 95	8
Determining Your Version of Windows 95	8
Installing with Windows 95	9
Version 4.00.950 or 4.00.950a	9
Installing with Windows 95	15
Version 4.00.950b (OSR2) or Later	15
Installing NetWare Client 32 ODI Drivers under Windows 95	16
Installing with Windows NT 3.51 and 4.0	18
Installing with Windows 3.x and Windows for Workgroups	21
Installing under IBM OS/2 (Warp 3.0 and 4.0) Using the NDIS or ODI Driver	22
Installing Network Software	25
Artisoft LANtastic version 6.0	26
AT&T StarGROUP LAN Manager version 2.1a	26
Banyan VINES version 5.5 & 6.0	26
DEC PATHWORKS versions 5.x or 6.x	28
FTP Software LANWatch	31
FTP Software PC/TCP	33
Generic Installation	37
HP LAN Manager	37

CONTENTS

IBM Local Area Network Support Program	38
IBM Local Area Network Support Program (version 1.2)	39
IBM PC LAN and IBM DOS LAN Requester	40
Manual Installation	41
Microsoft LAN Manager	41
Windows for Workgroups	43
Novell NetWare	47
SunSoft PC-NFS (version 3.5)	48
Novell NetWare 32-bit ODI Drivers	49
Ungermann-Bass Net/One for DOS	51
Wollongong PathWay Access for DOS	52

Configuration Reference..... 55

Who Should Consult This Chapter?	55
Special Features	56
Sample Configuration Files for Selected Network Operating Systems	60
Artisoft LANtastic/AI 6.0	60
Banyan VINES	63
DEC PATHWORKS 5.0 and 5.1	64
Windows for Workgroups 3.11	65
Windows for Workgroups Using the ODI Driver with NetWare as Secondary Network	67
Driver Parameters Reference	71
ODI Settings (for driver M32AODI.COM and M32AODI.OS2)	71
NDIS 2.0.1 Settings (for drivers M32ANDIS.EXE and M32ANDIS.OS2)	73
M32A.SYS (NDIS 3) Settings for Microsoft Windows NT and Windows 95	76
Novell Client 32 Driver Settings (for driver M32A.LAN)	79
Novell Client32 Driver Keywords	79
Packet Driver Settings (for driver	80
M32APD.COM)	80
Diagnostic Test Utility Settings (M32ATEST.EXE)	82
Keyword Alphabetical Reference	82

Troubleshooting..... 89

LED Indicators	90
Diagnostic Self Test (MS-DOS only)	91
Error Messages	94
General Troubleshooting	98

Network Operating System Troubleshooting 104
 Troubleshooting Checklist 116

Intel Automated Customer Support 119

Specifications 121
 General Specifications 121
 General Specifications (continued) 122
 Compatibility 122
 Technical Specifications 123

Limited Lifetime Warranty 125

Network Software License Agreement 129

Regulatory Agency Notices 133

Index 135

CONTENTS

Hardware Installation

Follow the instructions in this chapter to install the PRO/100 CardBus adapter hardware and network cabling. See **Chapter 2, Software Installation** for instructions on how to install network software.

The PRO/100 CardBus adapter provides access to both 10 Mbps and 100 Mbps networks with a single adapter cable, and auto-senses 10 Mbps or 100 Mbps network speed. **The Adapter requires Category 5 (data grade) unshielded twisted pair (UTP) cabling for 100 Mbps or Category 3 or 5 for 10 Mbps.**

Before Installing Hardware

Check Package Contents:

- PRO/100 CardBus adapter
- A LAN adapter cable with 15-pin PC Card connector at one end and a RJ-45 connector at the other (for 100Base-TX or 10Base-T Ethernet connectivity)
- Software on two 3.5-inch diskettes
- *Late Breaking News* card
- *User's Guide*
- Product registration card
- Protective adapter case

NOTE:

Please fill out the Product Registration Card and mail it immediately.

Verify Other Required Equipment

To install the PRO/100 CardBus adapter, you need the following:

- 1 A portable PC with a CardBus slot. Note that CardBus slots are different from 16-bit PCMCIA slots. If your CardBus adapter does not fit in your slot, it may be a 16-bit slot. Contact your computer dealer for more information.
- 2 A local area network supporting 10 or 100 Mbps Ethernet, as required, and a network operating system supported by the PRO/100 CardBus adapter. See **Chapter 2, Software Installation** for a list of the network operating systems supported.

NOTE:

Since the PRO/100 CardBus adapter automatically detects the speed of the network to which it is connected, it may be safely connected to either a 100Base-TX or 10Base-T network, as specified in items 3 and 4 below.

- 3 For connection to a 100Base-TX 100 Mbps Ethernet network, a **Category 5** (data grade) unshielded twisted pair (UTP) network cable terminating in a male RJ-45 connector.
- 4 For connection to a 10Base-T twisted pair Ethernet network, a network cable terminating in a male RJ-45 connector and connected to a 10 Mbps hub or switch.

Determine System Requirements

During installation of the PRO/100 CardBus adapter hardware, power to the computer should be ON and your operating system should be running. If configured to do so, your system will detect the PRO/100 CardBus adapter. For details on how to install driver software for your particular environment, see **Chapter 2, Software Installation**.

The PRO/100 CardBus adapter hardware is compatible with Types II and III PC Card slots that support CardBus technology. Installation and removal procedures may vary on different computers.

Installing the Hardware

Insert the PRO/100 CardBus adapter

- 1 Grasp the PRO/100 CardBus adapter by the edges with the Intel label facing upward and the wide PC Card connector next to the insert slot.
- 2 Insert the card into a CardBus slot and push it in until it is firmly seated.

NOTE:

The PRO/100 CardBus adapter will not fit in a slot that does not support CardBus technology.

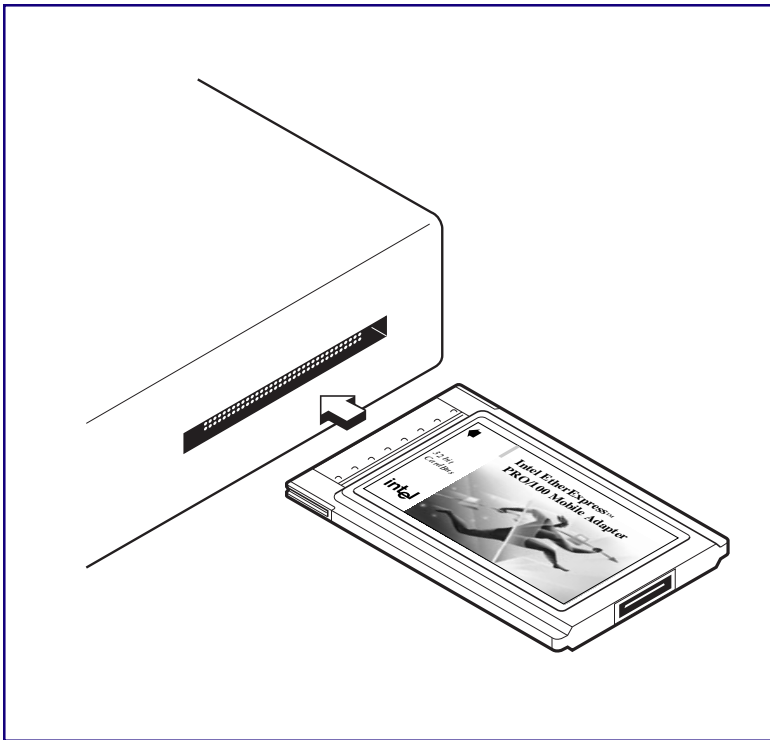

Inserting the PRO/100 CardBus adapter into the Computer

Removing the PRO/100 CardBus adapter

Follow the PC card removal instructions specified in the documentation for your computer.

Connecting the LAN Adapter Cable to the Card

- Attach the 15-pin connector at the end of the Intel adapter cable to the mating connector on the end of the adapter (see illustration below). Press the cable connector gently into the connector on the card until it clicks into place. Do not force the connection.

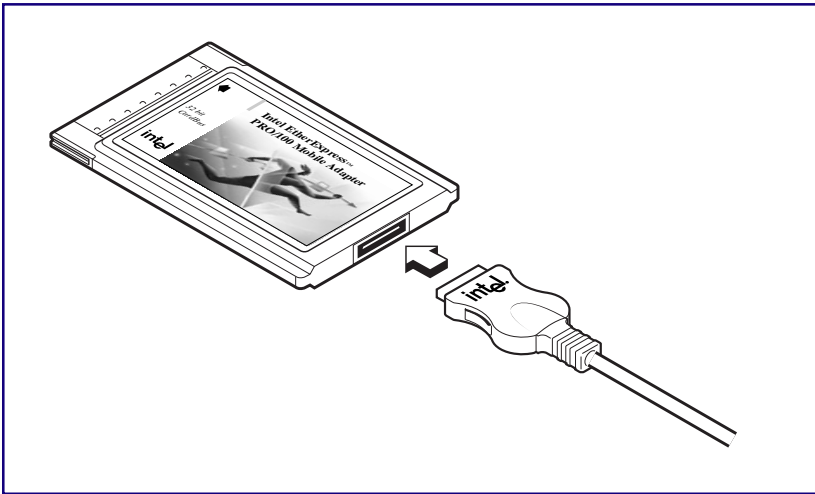

Connecting the LAN Adapter Cable to the PRO/100 CardBus adapter

Connecting the Network Cable to the LAN Adapter Cable

- Plug the network cable into the female RJ-45 connector, as shown in the figure.

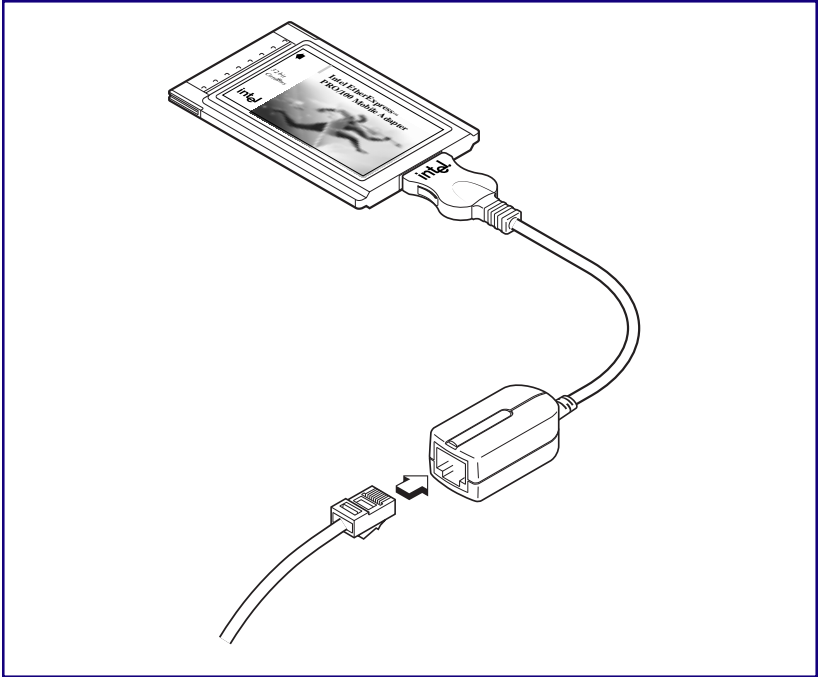

Connecting to the Network Cable to LAN Adapter Cable

What to Do Next

After installing the hardware and connecting cables, proceed to *Chapter 2. Software Installation*. You will need the Intel Installation Disk and Network Drivers Disk.

Software Installation

CardBus Installation Guidelines

The PRO/100 CardBus adapter can be used in Windows 3.x, Windows 95, Windows NT, and MS-DOS environments, and with most common network operating systems. However, some current operating systems or Card and Socket Services versions do not yet support CardBus technology. In these cases you will be able to use the PRO/100 CardBus adapter, but you will not be able to use or swap PC Cards or other CardBus adapters while using the adapter.

Installation instructions and guidelines are provided in this chapter for the fully supported and unsupported CardBus environments known at the time of publication.

The installation topics covered are:

- Windows* 95
- Windows 95 using Novell Client 32
- Windows NT*
- Windows 3.x, Windows for Workgroups
- IBM OS/2* Warp
- Others, listed in alphabetical order

Installing with Windows 95

The first release of Windows 95 (4.00.950 or 950a) included built-in support for 16-bit PC Cards but not for 32-bit CardBus. However, your PRO/100 CardBus adapter can still be installed under Windows 95. See the procedure on the next page.

Cardbus built-in support is included in Windows 95 OEM Service Release #2 (also known as Windows 95 OSR2 or version 4.00.950b).

Please review the README.TXT file on the Installation Disk and visit the Intel website for the latest information on CardBus support in Windows 95.

Determining Your Version of Windows 95

Follow the steps below to determine which version of Windows 95 you are running:

- 1 Click on the Start button.
- 2 Select Settings.
- 3 Select the Control Panel.
- 4 Double-click on the System icon.

The System Properties dialog box opens.

- 5 Select the General tab.

Information about your system is displayed, including the version of Windows 95 you are running, under “System.”

- Versions 4.00.950 or 4.00.950a. For installation procedures (including special instructions for Toshiba computers), see the section titled “Installing with Windows 95 Version 4.00.950 or 4.00.950a.”
- Version 4.00.950b (also known as OSR2). For installation procedures, see the section titled “Installing with Windows 95 Version 4.00.950b (OSR2) or Later.”

Installing with Windows 95 Version 4.00.950 or 4.00.950a

Windows 95 does not include 'Hot Swap' support for CardBus adapters. The PRO/100 CardBus adapter includes a driver that will let you use the device within Windows 95. To use this driver, however, you must first disable support for PC Cards in Windows 95. This means you cannot simultaneously use another CardBus adapter or PC Card with the PRO/100 CardBus adapter.

To install with Windows 95 Version 4.00.950 or 4.00.950a:

NOTE:

For Toshiba portable computers with CardBus support, see the separate installation instructions under the heading "Installing Toshiba Computers with Windows 95 version 4.00.950 or 4.00.950a" later in this section.

- 1** Insert the PRO/100 CardBus adapter.
- 2** Click Start.
- 3** Choose Settings.
- 4** Choose Control Panel.
The Control Panel opens.
- 5** Double-click the Network icon.
The Network window opens.
- 6** Click Add.
The Select Network Component Type window opens.
- 7** Double-click Adapter.
The Select Network Adapter window opens.
- 8** Click Have Disk.
The Install From Disk window opens.
- 9** Insert the Intel Drivers Disk.
- 10** With A:\ in input box, click OK (or type in the correct path).
The Select Network Adapter window reopens.

- 11 Under “Manufacturers,” click “Intel.”
- 12 Select the “Intel EtherExpress PRO/100 Mobile CardBus 32 **manual load.**” Note that this is the second driver listed. You may need to scroll the text to see the entire driver name.
- 13 Click OK.
- 14 The Network window reopens.
- 15 Click OK.

The Intel dialog box appears displaying various settings. An asterisk in any field indicates that the current setting is incorrect. Use the Up or Down arrow to adjust the setting until the asterisk disappears.

- 16 Click OK.

The Copying Files window opens.

- 17 Insert your original Windows 95 CD or disk (identify the drive that holds the CD or disk) and click OK.

The System Settings window opens.

NOTE:

If Windows 95 was pre-installed on your computer, the necessary files are located in the following directory:

C:\WINDOWS\OPTIONS\CABS

- 18 Click No when prompted to restart the computer. (But click Yes for Toshiba computers with CardBus support, as described in step 12 under the heading “Installing Toshiba Computers with Windows 95 version 4.00.950 or 4.00.950A” later in this section.)

DO NOT RESTART the computer at this time (unless you are using a Toshiba CardBus computer). First, complete the following steps to disable PC Card support:

NOTE:

Some portable computers require that PCMCIA support be disabled through the computer's BIOS in addition to the steps below. Before completing the following steps, please review the README.TXT file on the Network Drivers Disk for computer-specific information.

- 1** In the Control Panel, double-Click the System icon.
The System Properties window opens.
- 2** Click the Device Manager tab.
- 3** Double-click PCMCIA Socket.
- 4** Click PCIC or compatible PCMCIA controller.
- 5** Click Remove.
A removal confirmation window opens.
- 6** Click OK.
The System Settings Change window opens.
- 7** Remove the Network Drivers Disk from the floppy drive.
- 8** Click Yes to restart the computer.

When you restart the computer the first time after removing the PCIC device, you will be prompted to select a driver. Choose Do not install a driver. This prompt is not displayed again.

Re-enabling PC Card support with Windows 95 Version 4.00.950 or 4.00.950a

If you have disabled PC Card and Socket support in order to use the PRO/100 CardBus adapter, and now want to use another PC Card, such as a PC Card modem in your computer, you will first need to re-enable the PC Card support as described in the following steps:

- 1 Click Start.
- 2 Choose Settings.
- 3 Choose Control Panel.
The Control Panel window opens.
- 4 Double-click the Network icon.
The Network window opens.
- 5 Click the Configuration tab.
- 6 Select the “Intel EtherExpress PRO/100 Mobile CardBus 32 Manual Load.”
- 7 Click Remove.
- 8 Click OK.
- 9 Click No when prompted to restart the computer.

DO NOT RESTART the computer at this time. First, complete the following steps to re-enable PC Card support:

- 1 In the Control Panel, double-click the System icon.
The System Properties window opens.
- 2 Click the Device Manager tab.
- 3 Double-click PCMCIA Socket.
- 4 Double-click PCIC or Compatible Controller.
The PCIC or Compatible Controller Properties window opens.
- 5 Click the Drivers tab.
- 6 Click the Change Driver button.
The Select Device window opens.
- 7 Select “PCIC or compatible PCMCIA controller,” and click OK.
The PCIC or Compatible Controller Properties window reopens.

- 8 Click OK.

The System Properties window reopens.

- 9 Click Close.

- 10 Click Start.

- 11 Select Shut Down.

- 12 Select Restart the Computer and click Yes.

Your computer is now set to use other PC Card devices.

Installing Toshiba Computers with Windows 95 Version 4.00.950 or 4.00.950A

If you are installing the PRO/100 CardBus adapter on Toshiba portables with CardBus support, including the Tecra 700 series, Tecra 500 series and Protégé 650, please follow use the following installation procedures:

- 1 Determine which version of Windows 95 you have, using the guidelines under the heading “Determining Your Version of Windows 95” earlier in this chapter.
- 2 If your version of Windows 95 is version 4.00.950 or 4.00.950a, complete the following steps. If your version of Windows 95 is version 4.00.950b (OSR2) or later, follow the instructions later in this chapter for those versions.
- 3 Before installing the PRO/100 CardBus adapter, it is necessary to modify PC Card support on the computer via Toshiba’s BIOS setup program.
- 4 Press Start, and select Shutdown. Select Restart in MS-DOS mode to reboot your machine.
- 5 At the DOS prompt, run the Toshiba setup program by typing TSETUP and press Enter.
- 6 On the setup program menu, look for an item titled “PC Card Controller Mode”. If the mode is set to PCIC Compatible, proceed to step 7. If the mode is set to CardBus/16-bit, press the End button on your keyboard and then Y for Yes. Proceed to step 11.
- 7 Use the down arrow key to navigate through the Toshiba setup menu to the “PC Card Controller Mode” field.

- 8 Press the space bar until the PC Card Controller Mode is set to CardBus/16-bit.
- 9 Press the End button on your keyboard and press Y when prompted.
- 10 Reboot your computer.
- 11 Perform steps 1 through 17 under the heading “Installing with Windows 95 version 4.00.950 or 950a” at the beginning of the Installing with Windows 95 section earlier in this chapter.
- 12 After completing steps 1 through 17, select Yes when prompted to reboot the machine. At this point installation is complete.

Re-enabling PC Card support on Toshiba Computers

If you have disabled PC Card support in order to use the PRO/100 CardBus adapter under Windows 95 version 4.00.950 or 950a, and now want to use a PC Card, such as a PC Card modem in your computer, you will need to re-enable PC Card support by following these steps:

- 1 Click Start.
- 2 Choose Settings.
- 3 Choose Control Panel.
The Control Panel window opens.
- 4 Double-click the Network icon.
The Network window opens.
- 5 Click the Configuration tab.
- 6 Select the “Intel EtherExpress PRO/100 Mobile CardBus 32 Manual Load.”
- 7 Click Remove.
- 8 Click OK.
- 9 Click No when prompted to restart the computer.
- 10 Press Start, and select Shutdown. Select Restart in MS-DOS mode to reboot your machine.
- 11 At the DOS prompt, run the Toshiba setup program by typing TSETUP.
- 12 Use the down arrow key to navigate through the Toshiba setup menu to the “PC Card Controller Mode” field.
- 13 Press the space bar until the PC Card Controller Mode equals PCIC Compatible.

- 14 Press the End button on your keyboard and press Y when prompted.
- 15 Reboot your computer.
- 16 After your system has rebooted it is ready to support PC Cards under Windows 95.

Installing with Windows 95 Version 4.00.950b (OSR2) or Later

Windows 95 OSR2 and later versions support CardBus. This means you can use the built-in PC Card support in Windows 95 to install, remove, and hotswap CardBus cards and PC Cards.

To install the CardBus with Windows 95 Version 4.00.950b (OSR2) or later:

- 1 Insert the PRO/100 CardBus adapter.
- 2 Allow the Plug and Play facility to install the PRO/100 CardBus adapter.
- 3 When prompted for a disk, insert the Intel Network Drivers Disk.

Enabling another PCMCIA or CardBus card in Windows 95 Version 4.00.950b (OSR2) or Later

The PRO/100 CardBus adapter can be used simultaneously with another PCMCIA or CardBus card by using the Plug and Play feature to remove the PRO/100 CardBus adapter and install the new card.

Installing NetWare Client 32 ODI Drivers under Windows 95

When installing the PRO/100 CardBus adapter under Windows 95 you have the option of installing either an NDIS3 driver (also known as Miniport) or a 32-bit ODI client driver (Client 32).

Windows 95 installation instructions vary slightly for different versions of Windows 95. See the instructions earlier in this manual on how to determine your version of Windows 95, then follow the instructions below for your version.

Installing under Windows 95 Version 4.00.950 or 4.00.950a

- 1 Follow the instructions earlier in this chapter on how to disable PC Card support in Windows 95, under the heading Installing with Microsoft Windows 95 Version 4.00.950 or 4.00.950a.
- 2 Follow the steps below for Client 32 installation under Windows 95 Version 4.00.950b. However, you may use any version of the Client 32 Install Software.

Installing under Windows 95 Version 4.00.950b or later (OSR2)

NOTE

Windows 95 version 4.00.950b requires Client 32 for Windows 95 version 2.12 or greater (ask your Network Administrator if you do not know which version of NetWare Client 32 you have).

- 1 Follow the instructions earlier in this chapter for installing the Intel PRO/100 CardBus adapter under Windows 95 version 4.00.950b. This procedure will install the adapter with the NDIS3 (Miniport) driver.
- 2 Click the Start button in the left bottom corner of your Windows 95 Desktop and select Run. Then type the path to SETUP.EXE or Browse to the Client 32 install directory. Possible paths are:

A:\

if installing from Disk 1 of the diskette version

C:\DIRECTORY_NAME\

if installing from a directory on your hard disk

\\NOVELL_SRV_NAME\SYS\PUBLIC\CLIENT\WIN95\IBM_ENU\

if installing from a Novell NetWare Server you are connected to.

- 3 Once you have selected the proper path, run SETUP.EXE and follow the Novell instructions. At the last screen, DO NOT select REBOOT. Instead, click CUSTOMIZE.

NOTE

If prompted to insert the Windows 95 CD-ROM, click OK and type the path to the CABS directory on your hard drive (usually C:\WINDOWS\OPTIONS\CABS).

- 4 The CUSTOMIZE option will take you to the Network dialog box where you may or may not have an adapter installed. DO NOT REMOVE any of the existing drivers. First ADD the 32 Bit ODI driver by selecting Add. Then in the Select Network Adapter Type box select Adapter. Next, in the Select Network Adapters box click Have disk and insert the Intel Network Drivers Disk (Disk 2). Select OK at the Install from Disk box. In the next window highlight Intel in the manufacturers column and Intel EtherExpress PRO/100 CardBus Adapter for NetWare Client 32 V1.0.
- 5 This will take you back to the Network window where you may now remove the existing driver if there was one. You should be left with a Novell ODINSUP and an Intel PRO/100 CardBus adapter for NetWare Client 32 V1.0 adapter.
- 6 If your laptop requires any special resources, you may select the adapter and Properties window to change them. Otherwise click OK .

NOTE

If asked to insert the NetWare Client 32 for Windows 95 Disk x click OK and enter the path to the Client 32 Install from Step 2 above.

- 7 After rebooting, the driver will load but you may receive a New Hardware Found PCI Card message which will take you to the Update Device Driver Wizard window. At this window make sure you DO NOT have the drivers disk in drive A:. Then click Next >. The next window should display "Windows was unable to locate a driver for this device." Now click Finish. You should not see this message in subsequent reboots. This step will leave a "?!PCI Card" indication in the Control Panel\System Properties\Device Manager\Other Devices section, but will not hinder operation of the driver. However, if you wish to reinstall the Miniport driver at a later time be sure, to remove the "?!PCI Card" line from the above named window.

Installing with Windows NT 3.51 and 4.0

Windows NT 3.51 and 4.0 include full support for PC Cards and partial support for CardBus. The PRO/100 CardBus adapter includes a driver that will let you use the device within Windows NT. When loaded, this driver disables support for PC Cards in Windows NT. This means you cannot simultaneously use another CardBus or PC Card with the PRO/100 CardBus adapter.

Please review the README.TXT file on the Installation Disk and visit the Intel website for the latest information on CardBus support in Windows NT.

The installation steps for Windows NT 3.51 and Windows NT 4.0 are slightly different, so they are addressed separately here.

To install with Windows NT 3.51:

- 1 Insert the PRO/100 CardBus adapter.
- 2 Double-click the Control Panel.
The Control Panel opens.
- 3 Double-click the Network icon.
The Network Settings window opens.
- 4 Click Add Adapter.
The Add Network Adapters window opens.
- 5 Scroll to select "Other (requires disk from manufacturer)."
- 6 Click Continue.
The Insert Disk windows opens.
- 7 Insert the Intel Network Drivers Disk .
- 8 Click OK.
The Select OEM Option window opens.
- 9 Click OK.
- 10 Intel EtherExpress PRO/100 CardBus Mobile Adapter Setup window opens, displaying the default settings.

NOTE:

In most circumstances, the default settings will properly operate the PRO/100 CardBus adapter. However, consult the README.TXT file for specific settings (if necessary).

- 11 Click OK.
The Network Settings window reopens.
- 12 Click OK.
The Network Settings Change window opens.
- 13 Click Restart Now to restart your computer.

Re-enabling PC Card Support in Windows NT 3.51

The PRO/100 CardBus adapter cannot be used simultaneously with a PC Card in Windows NT 3.51.

To remove the PRO/100 32-bit Mobile Adapter from Windows NT 3.51:

- 1 Double-click the Control Panel.
The Control Panel opens.
- 2 Double-click the Network icon.
The Network Settings window opens.
- 3 Choose the “Intel EtherExpress PRO/100 Mobile CardBus 32.”
- 4 Click Remove.
- 5 Click Yes to confirm.

To install with Windows NT 4.0:

- 1 Insert the PRO/100 CardBus adapter.
- 2 Click Start.
- 3 Choose Settings.
- 4 Choose the Control Panel.
The Control Panel opens.
- 5 Double-click the Network icon.
The Network Settings window opens.
- 6 Click the Adapters tab.
The Network Adapters window opens.
- 7 Click Add.
The Select Network Adapter window opens.
- 8 Click Have Disk.

- 9 Insert the Intel Network Drivers Disk .
- 10 Click OK.
The Select OEM Option window opens.
- 11 Click OK.
Windows NT Setup window briefly displays.
- 12 PRO/100 CardBus adapter Settings window opens, displaying the default settings.

NOTE:

In most circumstances, the default settings will properly operate the PRO/100 CardBus adapter. However, consult the README.TXT file for specific settings (if necessary).

- 13 Click OK.
The Network Settings window redisplay.
- 14 Click Close.
If any dialog boxes appear related to setting up network protocols, click Cancel, and contact your Network Administrator.
- 15 When the Network Settings Change window opens, click Yes to restart your computer.

Re-enabling PC Card Support in Windows NT 4.0

The PRO/100 CardBus adapter cannot be used simultaneously with a PC Card in Windows NT 4.0.

To remove the PRO/100 CardBus adapter from Windows NT 4.0:

- 1 Double-click the Control Panel.
The Control Panel opens.
- 2 Double-click the Network icon.
The Network Settings window opens.
- 3 Choose the “Intel EtherExpress PRO/100 Mobile CardBus 32.”
- 4 Click Remove.

Installing with Windows 3.x and Windows for Workgroups

To install under **Windows 3.x** or **Windows for Workgroups**, use the Intel Installation Program. Insert the Installation Disk, into your disk drive, and proceed as follows (substitute the correct drive letter for your system):

- 1 From the Program Manager, choose File, then Run. In the Command Line box, type the following:
A:SETUP
- 2 Press Enter or click OK.
- 3 Select your network operating system from the list displayed and click OK.
- 4 Follow the on-screen instructions. Note the following variations for NetWare and other network operating systems:

Novell NetWare Installation

With Novell NetWare highlighted, click the **OK** button. Intel provides all software necessary to configure your NetWare client workstation. Upon completion, the Installation Program will reboot your system. When your system comes back up, log in to the network.

NOTE:

The NetWare VLM shell is used to connect to your NetWare server. The Intel Installation Program will decompress and configure the necessary files. If you do not plan to use the Installation Program, see "Manual Installation" in the alphabetical section of this chapter for instructions on how to decompress and load the NetWare VLM files.

If you need NETX shell support, contact your System Administrator.

Installation of Other Network Operating Systems

For listed network operating systems other than Novell NetWare, highlight your network operating system and click the **OK** button. The Intel installation software will analyze your system and create a custom Intel Network Drivers Disk. Make sure your diskette is not write-protected when executing this step.

- 5 Once you have completed the steps prompted by the Intel Installation Program, exit the program and find your network operating system in this chapter of the User's Guide, using the **alphabetical listing** under the heading "Installing Network Software." Follow the procedures indicated there **to complete the installation**.

NOTE:

Even though older Card and Socket Services software for MS-DOS and Windows 3.X may not support CardBus, it may be possible to use another PC Card simultaneously with the PRO/100 CardBus adapter. Please refer to the README.TXT file or the Intel website for the latest information and tips regarding Card and Socket Services.

The Installation Program will modify your AUTOEXEC.BAT, CONFIG.SYS, and network configuration files to match the optimum configuration for your system.

For detailed technical information on configuration files and settings, see **Chapter 3, Configuration Reference** and **Chapter 4, Troubleshooting**.

Installing under IBM OS/2 (Warp 3.0 and 4.0) Using the NDIS or ODI Driver

NOTE

The PRO/100 CardBus adapter includes NDIS 2.0 and ODI drivers for OS/2. Currently, the Card and Socket Services software in OS/2 does not support CardBus. Therefore, in order to install the CardBus driver in OS/2, OS/2's Card and Socket Services must be disabled. Follow IBM's instructions for disabling Card and Socket Services.

Installation Steps for Warp 3.0 and 4.0 (NDIS driver)

- 1 Remove OS/2's Card and Socket Services according to IBM's instructions.

By default, the CardBus NDIS driver will be installed. If you wish to install the ODI client, the Novell Client installation program should be used. See the OS/2 ODI Client install section for instructions.

- 2 Run MPTS (Multi-Protocol Transport Services). For Warp 3.0, MPTS is on the desktop. For Warp 4.0, MPTS is in System Setup.
- 3 In the MPTS window, click on Configure
- 4 In the Configure window, select the LAN adapter and protocols radio button, then click on Configure.
- 5 In the LAPS Configuration window, in the Network Adapter section, click on Other Adapter.

- 6 Set the path as A:\NDIS and click OK.
- 7 Back at the LAPS Configuration window, in the Network Adapter section, select the PRO/100 CardBus adapter by clicking on it and then clicking Add.
- 8 In the Protocols section, select the protocols you wish to use by clicking on the protocols and then clicking Add.
- 9 In the Current Configuration section, click on PRO/100 CardBus adapter and click edit to edit the driver settings. The default settings for the product will be displayed. Generally, the default settings should be used. The most important to check are INT and SOCKET. If there is a conflict, these should be adjusted using trial and error.
- 10 After reviewing the settings, click OK.
- 11 Click OK again
- 12 Click close
- 13 Follow the onscreen instructions to complete installation.

NOTE

In Warp 4.0, a free interrupt can be found by running Hardware Manager (under System Setup). Under IRQ, look for a free one (the program shows what's used).

Installation Steps for Warp 3.0 and 4.0 (ODI driver)

The PRO/100 CardBus adapter includes NDIS2 and ODI drivers for OS/2. Currently, the Card and Socket Services software in OS/2 does not support CardBus. Therefore, in order to install the CardBus driver in OS/2, OS/2's Card and Socket Services must be disabled. Follow IBM's instructions for disabling Card and Socket Services.

- 1 Remove OS/2's Card and Socket Services according to IBM's instructions.
- 2 In order to install Intel's OS/2 ODI driver, the Novell Netware Client for OS/2 installation disks are needed. Insert disk 1 of the OS/2 client installation disks (the WSOS2_1 disk) in the floppy drive and run INSTALL.
- 3 In the NetWare Workstation for OS/2 Installation Utility window, click the Installation menu item and select the Requester on Workstation option.
- 4 In the 'Set Target Directory' Windows, set the destination directory (default is c:\netware) and click OK.

- 5** In the 'Requester Installation' window, select the the option 'Edit CONFIG.SYS and copy all files' and click OK.
- 6** In the 'Step 1- choose the ODI LAN Driver' window, click on the list box to display the list of LAN drivers. An Installation Message window will appear. Put the Intel Network Drivers Disk in the floppy drive and click OK.
- 7** In the list box, enter M32AODI.OS2 as the LAN driver to install, and click Continue.
- 8** The Installation Message window will reappear. Re-insert the NetWare Client disk in the floppy drive (disk WSOS2_1) and click OK.
- 9** Follow the onscreen instructions to complete the installation of the Netware Client for OS/2 software.

Installing Network Software

Use the instructions under this heading in the following circumstances:

- To complete the installation of network software *after you have run the Intel Installation Program*: Find your network operating system in the alphabetical listing that follows.
- To install software for network operating systems not supported by the Intel Installation Program (for example, on systems running MS-DOS without Windows): Find your network operating system in the alphabetical listing that follows, or see the headings “Generic Installation” and “Manual Installation” in the same listing.
- To install and configure manually, without running the Intel Installation Program: See the heading “Manual Installation” in the alphabetical listing that follows.

Use the Modified Intel Network Drivers Disk

When prompted for a device driver or manufacturer’s disk by your network operating system install procedure, use Intel Network Drivers Disk.

Alphabetical Reference

The section is organized in alphabetical order by network operating system vendor. Unless otherwise indicated, *these instructions are designed to be used with the Intel Installation Program*. They assume a first-time installation of client software on a workstation, using the configuration values set by the Intel Installation Program or, when the Installation Program is not used, using the default values listed in **Chapter 3, Configuration Reference**.

The PRO/100 CardBus adapter supports ODI, NDIS 2.01, NDIS 3 and packet drivers. To determine which of these drivers you need for your networking environment, consult your network administrator or network documentation.

Artisoft LANtastic version 6.0

NDIS 2.0 Driver

- 1 Run the Intel Installation Program from the Installation Disk.
- 2 Choose Artisoft LANtastic from the Select Network Operating System screen.
- 3 Follow the prompts to complete the Intel segment of the installation.
- 4 Run the Artisoft LANtastic 6.0 “install” program. Specify C:\LANTASTI as the destination directory (or the directory set with the Intel Installation Program).
- 5 At the “Select network adapter” screen, choose “NDIS Support for Network Adapters.”
- 6 When prompted for the “manufacturer’s driver disk” on the “Enter NDIS driver directory” screen, insert the Intel Network Drivers Disk.
- 7 Complete the Artisoft installation.
- 8 Reboot the computer and start LANtastic.

AT&T StarGROUP LAN Manager version 2.1a

NDIS 2.0 Driver

See Microsoft LAN Manager.

Banyan VINES version 5.5 & 6.0

NDIS 2.0 Driver

Prior to installing the Banyan Vines client software, it is necessary to determine the Interrupt Number for the PRO/100 CardBus adapter. After you have installed the Adapter, follow these steps to determine the Interrupt Number:

- 1 Insert the Intel Network Drivers Disk in the floppy drive.
- 2 At the DOS prompt, enter
M32ATEST
- 3 Press Enter.
- 4 When the Main Menu opens, run Test.
The IRQ number will be displayed when the Test is complete.

- 5 Write down the IRQ number to use when you proceed with the installation.

For example, if the IRQ=6, write down the number 6.

Now continue with the Banyan Vines installation as follows:

- 1 Run the Intel Installation Program from the Installation Disk.
- 2 Choose Banyan VINES from the Select Network Operating System screen.
- 3 Follow the prompts to complete the Intel segment of the installation. The Installation Program also creates a \VINES directory on your hard disk.
- 4 Copy the files from the VINES Master disk into the VINES directory.
- 5 Copy the NDIS driver file and the PROTOCOL.INI file from \NDIS directory on the Network Drivers Disk into the VINES directory.
- 6 Change to the VINES directory.
- 7 Type PCCONFIG and select Network Card Settings, followed by NDIS Ethernet.
- 8 Enter the IRQ value you wrote down in Step 5 of the M32ATEST procedure above.
- 9 At the PROTOCOL.INI bindings prompt, type INTELNET.
- 10 Press F10 to save and Esc to return to the main menu.
- 11 Select Login Environment Settings, followed by Default Communications Driver, followed by NDIS Ethernet.
- 12 Press Esc to return to the Main Menu and press F10 to save.
- 13 Manually add these lines to your AUTOEXEC.BAT file:
`CD\VINES`
`BAN`
- 14 Manually add these lines to your CONFIG.SYS file:
`DEVICE=C:\VINES\PROTMAN.DOS /I:C\VINES`
`DEVICE=C:\VINES\M32ANDIS.EXE`

DEC PATHWORKS versions 5.x or 6.x

NDIS 2.0 Driver

These instructions are based on PATHWORKS documentation for configuration of a PC as a client workstation, using a system service already installed on a LAN Manager server and the LAN Manager SETUP diskette.

Prior to installing the DEC PATHWORKS client software, it is necessary to determine the Interrupt Number for the PRO/100 CardBus adapter. After you have installed the PRO/100 CardBus adapter, follow these steps to determine the Interrupt Number:

- 1 Insert the Intel Network Drivers Disk in the floppy drive.
- 2 At the DOS prompt, enter
`M32ATEST`
- 3 Press Enter.
- 4 When the Main Menu opens, run Test.
The IRQ number will be displayed when the Test is complete.
- 5 Write down the IRQ number to use when you proceed with the installation.
For example, if the IRQ=6, write down the number 6.

Now continue with the DEC PATHWORKS installation as follows:

- 1 Run the Intel Installation Program from the Installation Disk.
- 2 Choose DEC PATHWORKS from the Select Network Operating System screen.
- 3 Follow the prompts to complete the Intel segment of the installation.
- 4 Check the README file on your PATHWORKS SETUP disk for requirements such as lastdrive, setver, etc. You will need 500 K of free conventional memory and about 1 MB of extended memory to run PATHWORKS SETUP. Be sure you have a lastdrive statement in your CONFIG.SYS file (lastdrive=g will work in most cases).
- 5 Use a text editor to modify the file A:\NDIS\PI.TPL on the PATHWORKS SETUP disk, as follows (A:\NDIS is a hidden directory. You can access it by typing CD A:\NDIS):
Change the line (remove the semicolon)

;NI_IRQ = [IRQ VALUE FROM STEP 5 OF THE FIRST PROCEDURE ABOVE]

to read

NI_IRQ = [IRQ VALUE FROM STEP 5 OF THE FIRST PROCEDURE ABOVE]

The NI_IRQ value must be the same as the interrupt value you will use for the Intel adapter.

6 Run the SETUP program from the PATHWORKS SETUP disk for LAN Manager.

7a For Pathworks 5.0, choose Configure PC.

7b For Pathworks 6.0, select Yes for the “Has the Pathworks software been installed to a LAN Manager file Service.”

8 In the Select Drive Window, choose “Network.”

9 Select DECnet as transport.

10 When prompted to choose a network adapter, choose “Other.”

11 When prompted for driver information, in the “Other Adapter” window use the following:

a. for PATHWORKS 5.0:

NDIS DRIVER PATH: A:

NDIS DRIVER FILE: M32ANDIS.EXE

NDIS DRIVER NAME: INTEL\$

b. for PATHWORKS 5.1:

DRIVER FILE: A:\M32ANDIS.EXE

PROTOCOL.INI STUB: A:\DEC\PROTOCOL.INI

c. for PATHWORKS 6.0:

DRIVER FILE: A:\M32ANDIS.EXE

PROTOCOL.INI STUB: A:\DEC\PROTOCOL.INI

Skip the Additional Files section.

12 Insert the Intel Network Drivers Disk when prompted.

13 Enter your node information when prompted.

14 Save the PROTOCOL.INI file with the default settings.

At this point, the SETUP program will try to connect to the DECnet server. Once connected, the SETUP program will map a logical drive to your system service.

- 15 Highlight the logical drive mapped by the SETUP program, and press Enter to run PWSETUP.
- 16 Press Enter to confirm the Software Destination C:\PW.
- 17 Choose Express (or Custom if you have a lot of prior installation experience).
- 18 Select an appropriate Workstation Template, or create one.
- 19 Under Network Adapter Information, choose other network adapter, with NDIS enabled, and enter the following information:
IN THE NON-SUPPORTED NETWORK ADAPTER WINDOW
DRIVER FILE: A:\M32ANDIS.EXE
PROTOCOL.INI STUB: A:\DEC\PROTOCOL.INI
- 20 Insert the Intel Network Drivers Disk when prompted.
- 21 In the Network Adapter Information window, select M32ANDIS Unsupported Network Adapter with NDIS Box enabled
- 22 In LAN Manager System Service Connection Information window, enter username and press Enter.
- 23 Enter the Windows directory path.
- 24 Press Enter to add the STARTNET.BAT file to your AUTOEXEC.BAT file.
- 25 A PROTOCOL.INI file created by SETUP will display in edit mode.

- a Remove the semicolon at the beginning of the ni_irq line, as follows:

Change the line

```
;NI_IRQ = [IRQ VALUE FROM STEP 5 OF THE FIRST PROCEDURE ABOVE]
```

to read

```
NI_IRQ = [IRQ VALUE FROM STEP 5 OF THE FIRST PROCEDURE ABOVE]
```

The **ni_irq** value must be the same as the interrupt value used for the Intel adapter.

- b Verify that the **[m32andis]** section has the following lines and settings:

```
[M32ANDIS]  
DRIVERNAME=INTEL$
```

- 26 Exit SETUP and reboot to start the network. (Some machines may require a cold boot at this point—power the computer down and back up again.)

FTP Software LANWatch

Packet and NDIS 2.0 Drivers

FTP Software's LANWatch network monitor software can be installed using Intel's packet or NDIS 2.0 drivers. For information on which driver is appropriate for your network environment, refer to the FTP LANWatch documentation.

FTP Software LANWatch Packet Driver Installation

- 1 Run the Intel Installation Program from the Installation Disk.
- 2 Choose FTP LANWatch from the Select Network Operating System screen.
- 3 Follow the prompts to complete the Intel segment of the installation.
- 4 Install LANWatch according to the instructions in your FTP LANWatch manual.
- 5 Copy the file M32APD.COM from the C:\INTEL\M32A directory to the directory where your LANWatch files are stored.
- 6 (This step is not required for LANWatch versions 3.0 and later.)
Using a text editor, add the following line to your CONFIG.SYS file:

```
DEVICE = [PATH]IFCUST.SYS
```

where *[path]* is the drive and directory where your LANWatch files are stored.

- 7 Reboot the PC.
- 8 Change to the directory of where your LANWatch files are stored and run M32APD.COM.
- 9 Run LW.EXE.

FTP Software LANWatch NDIS 2.0 Driver Installation

- 1 Run the Intel Installation Program from the Installation Disk.
- 2 Choose FTP LANWatch from the Select Network Operating System screen.
- 3 Follow the prompts to complete the Intel segment of the installation.
- 4 Install LANWatch according to the instructions in your FTP LANWatch manual.
- 5 Using a text editor, add the following lines to your CONFIG.SYS file:

```
DEVICE = C:\NDIS\PROTMAN.SYS /I:C:\NDIS
```

```
DEVICE = C:\NDIS\M32ANDIS.EXE
```

```
DEVICE = C:\NDIS\DIS_PKT.GUP
```

(Include the following line for LANWatch versions earlier than 3.0 only)DEVICE = C:\LW\IFCUST.SYS

- 6 Create a directory called NDIS on your hard disk, by typing:

```
MD NDIS
```
- 7 At the DOS prompt, copy M32ANDIS.EXE from the C:\INTEL\M32A directory on your hard disk and the file PROTOCOL.FTP from the \NDIS directory on the Intel Network Drivers Disk to the \NDIS directory you created in Step 6.
- 8 Use a text editor to modify the PROTOCOL.FTP file to match the keywords and values in the sample PROTOCOL.INI file in the \INTEL\M32A directory.
- 9 Copy all the files from the \NDIS directory on the FTP Unsupported Software Disk A to the \NDIS directory created in Step 6.
- 10 Reboot the PC.
- 11 Change to the \NDIS directory and run NETBIND.EXE.
- 12 Run LW.EXE.

FTP Software PC/TCP

Packet, NDIS 2.0, and ODI Drivers

FTP Software's PC/TCP Generic Ethernet Kernel ETHDRV.EXE can be installed using Intel's Packet, ODI, or NDIS drivers. PC/TCP can also be used concurrently with NetWare. For information on which driver is appropriate for your network environment, see the FTP PC/TCP documentation. For environments using values other than those set by the Intel Installation Program, see **Chapter 3, Configuration Reference** in this manual.

FTP PC/TCP 3.X with OnNet 1.1 and Windows for Workgroups 3.11

- 1 Run the Intel Installation Program from the Installation Disk.
- 2 From the Select Network Operating System screen, choose Windows for Workgroups then FTP PC/TCP 3.x.
- 3 Follow the prompts to complete the Intel segment of the installation.
- 4 Run the PC/TCP installation program OnNet 1.1.
- 5 Follow the prompts to the Network Card Screen, then select "Other NDIS Driver or Updated Packet Driver."
- 6 Insert the Intel Network Drivers Disk when prompted.
- 7 Choose the appropriate driver then follow prompts to complete the installation.
- 8a For NDIS installation, reboot the PC.
- 8b For ODI installation, *do not reboot*. Continue with step 9.

Additional Steps for ODI Installation

If you are using an ODI driver, continue with the following steps:

- 9 Change to the directory into which PC/TCP was installed.
- 10 Use a text editor to change the file PCTCP.INI as follows:
 - In the section PCTCP ifcust 0 change the line
`INTERFACE-TYPE=NDIS`
to read
`INTERFACE-TYPE=PKTDRV.`
- 11 Save the file and exit the text editor.
- 12 Change to the C:\ (root) directory.

- 13** Use a text editor to modify the AUTOEXEC.BAT file as follows (\PCTCP is the default installation directory):
- Move the line containing the STARTNET.BAT command or the lines containing the network driver files to immediately above the line

```
SET PCTCP=C:\PCTCP\PCTCP.INI
```
 - Add the line

```
C:\PCTCP\ODIPKT
```

after the line

```
PCTCP=C:\PCTCP\PCTCP.INI
```
- 14** Save the file and exit the text editor.
- 15** Copy the file ODIPKT from disk 5 of the FTP PC/TCP installation disks to the directory into which PC/TCP was installed.
- 16** Reboot the PC. FTP PC/TCP 3.X with OnNet 1.1 with Windows 3.1

FTP PC/TCP 3.X with OnNet 1.1 with Windows 3.1

- 1** Run the Intel Installation Program from the Installation Disk.
- 2** From the Select Network Operating System screen, choose FTP PC/TCP.
- 3** Follow the prompts to complete the Intel installation.
- 4** Run the PC/TCP installation program OnNet 1.1.
- 5** When prompted, insert the Intel Network Drivers Disk.
- 6** Follow prompts to complete the PC/TCP installation.
- 7a** For an NDIS installation, reboot the PC.
- 7b** For ODI installation, *do not reboot*. Continue with step 8.

Additional Steps for ODI Installation

If you are using an ODI driver, continue with the following steps:

- 8** Change to the directory into which PC/TCP was installed.
- 9** Use a text editor to change the file PCTCP.INI as follows:

- In the section PCTCP ifcust 0 change the line

```
INTERFACE-TYPE=NDIS
```

to read

```
INTERFACE-TYPE=PKTDRV.
```

- 10 Save the file and exit the text editor.
- 11 Change to the C:\ (root) directory.
- 12 Use a text editor to modify the AUTOEXEC.BAT file as follows (\PCTCP is the default installation directory):
 - Move the line containing the STARTNET.BAT command or the lines containing the network driver files to immediately above the line

```
SET PCTCP=C:\PCTCP\PCTCP.INI
```
 - Add the line

```
C:\PCTCP\ODIPKT
```

after the line

```
PCTCP=C:\PCTCP\PCTCP.INI
```
- 13 Save the file and exit the text editor.
- 14 Copy the file ODIPKT from disk 5 of the FTP PC/TCP installation disks to the directory into which PC/TCP was installed.
- 15 Reboot the PC.

FTP Software PC/TCP Packet Driver Installation with OnNet 1.1

- 1 Run the Intel Installation Program from the Installation Disk.
- 2 Choose FTP PC/TCP from the Select Network Operating System screen.
- 3 Follow the prompts to complete the Intel segment of the installation.
- 4 Exit to DOS, switch to the C:\INTEL\M32A directory and run M32APD.COM.
- 5 Install PC/TCP software according to the directions given in the PC/TCP documentation.
- 6 Copy the file M32APD.COM from the C:\INTEL\M32A directory to the PC/TCP directory specified in the PC/TCP install procedure.

- 7 Edit the AUTOEXEC.BAT file and add the following lines:
`C:\PCTCP\M32APD.COM`
`C:\PCTCP\ETHDRV.EXE`
- 8 (This step is not required for PC/TCP versions 2.10 and later.) Using a text editor, add the following lines to your CONFIG.SYS file:
`DEVICE=[PATH]IPCUST.SYS`
`DEVICE=[PATH]IFCUST.SYS`
where *[path]* is the drive and directory specified at the PC/TCP installation.
- 9 Reboot the PC.
- 10 Change to the directory where your PC/TCP files are stored and run M32APD.COM by typing: M32APD and pressing Enter.
- 11 Run the ETHDRV.EXE kernel program supplied with PC/TCP. This loads the PC/TCP kernel into memory. The packet driver must always load before the kernel.
- 12 Continue your server or workstation startup as instructed in the PC/TCP documentation.

ODI with FTP Software PC/TCP and NetWare

If you need to run Novell NetWare concurrently with FTP PC/TCP, proceed as follows:

- 1 Run the Intel Installation Program from the Installation Disk.
- 2 Choose FTP PC/TCP from the Select Network Operating System screen.
- 3 Follow the prompts to complete the Intel segment of the installation.
- 4 Install PC/TCP according to the instructions in your FTP PC/TCP manual.
- 5 (This step is not required for PC/TCP versions 2.10 and later.) Using a text editor, add the following lines to your CONFIG.SYS file:
`DEVICE=[PATH]IPCUST.SYS`
`DEVICE=[PATH]IFCUST.SYS`

where *[path]* is the drive and directory specified in the PC/TCP installation.

- 6 Copy NET.CFG from the C:\INTEL\M32A directory and the files LSL.COM and M32AODI.COM from the root directory of the Intel Network Drivers Disk to the PC/TCP directory created in the PC/TCP install procedure.
- 7 To start the workstation, load the software as follows:
 - LSL
 - M32AODI
 - IPXODI
 - ODIPKT (USE THE VERSION SUPPLIED WITH PC/TCP)
 - ETHDRV
 - VLM
- 8 Change to the network drive (usually F:\LOGIN).
- 9 Log in to the network.

Generic Installation

If your NOS is not listed in the Intel Installation Program, you can try selecting “Generic NDIS Driver” or “Generic ODI Driver” in the Intel Installation Program and clicking the Install button. A sample configuration file containing parameters optimized for your system will be created in the \INTEL\M32A directory on your hard disk. For NDIS, this will be a custom PROTOCOL.INI file. For ODI, it will be a custom NET.CFG file. Use this sample file to assist you in configuring the actual configuration file for your system (or use the sample file itself if appropriate).

HP LAN Manager

NDIS 2.0 Driver

See Microsoft LAN Manager.

IBM Local Area Network Support Program

IBM Local Area Network Support Program (version 1.36)

NDIS 2.0 Driver

- 1 Run the Intel Installation Program from the Installation Disk.
- 2 Choose IBM LAN Support Program from the Select Network Operating System screen.
- 3 Follow the prompts to complete the Intel segment of the installation.
- 4 Install the IBM Local Area Network Support Program according to the instructions in the IBM Local Area Network Support Program User's Guide.
- 5 Under Environment Information, respond "no" to the question "Do you have adapter option disks?"
- 6 Choose the Intel CardBus adapter from the list provided.
- 7 If prompted to do so, insert the Intel Network Drivers Disk when prompted and type the path
A:\NDIS
- 8 Press Esc twice to bypass error messages.
- 9 Continue with the installation until finished.
- 10 Use a text editor to add the following two lines in your CONFIG.SYS file at the location indicated by the "rem" statement concerning insertion of the driver name:
DEVICE=\LSP\M32ANDIS.EXE
- 11 Copy M32ANDIS.EXE from the directory C:\INTEL\M32A to the C:\LSP directory on your hard disk.
- 12 Use a text editor to edit the PROTOCOL.INI keyword settings in the C:\LSP directory to match the keywords contained in the sample PROTOCOL.INI file located at C:\INTEL\M32A as required (unless you are using PRO/100 CardBus adapter default settings).
- 13 Save the files and reboot the PC.

IBM Local Area Network Support Program (version 1.2)

NDIS 2.0 Driver

- 1 Run the Intel Installation Program from the Installation Disk.
- 2 Choose IBM LAN Support Program from the Select Network Operating System screen.
- 3 Follow the prompts to complete the Intel segment of the installation.
- 4 Install the IBM Local Area Network Support Program according to the instructions in the IBM Local Area Network Support Program User's Guide. The following instructions refer to the prompts and messages displayed with the Configuration Aid automated install software provided with the LAN Support Program.
- 5 If a message appears during the LAN Support Program installation indicating there are no IBM LAN adapters installed in the workstation, bypass the message by pressing Enter.
- 6 Answer [N]o to program support for the PC Network Adapter.
- 7 Answer [Y]es to use of programs needing the NETBIOS interface.
- 8 When prompted, select the Etherand Network family of network cards.
- 9 Continue with the installation until finished.
- 10 Use a text editor to replace the line in your CONFIG.SYS file that reads:

```
DEVICE=\XX.DOS
```

with the line

```
DEVICE=M32ANDIS.EXE
```
- 11 Still in the CONFIG.SYS file, add the parameter O=N (where O is a letter, not zero) to the line

```
DEVICE=\DXMT0MOD.SYS
```

as follows

```
DEVICE=\DXMT0MOD.SYS O=N
```
- 12 Copy M32ANDIS.EXE from the directory C:\INTEL\M32A to the root directory of your hard disk or boot disk.

- 13 Change to the LANMAN directory on your hard disk or boot disk.
- 14 Use a text editor to modify the PROTOCOL.INI file in the C:\LSP directory as follows:
 - Under the ETHERAND section, change the line that reads
BINDINGS = TCMAC2
to read:
BINDINGS = INTELNET
 - Underneath that section insert a new section that reads:
[INTELNET]
DRIVERNAME = INTEL\$
- 15 Use a text editor to edit the keyword settings in the PROTOCOL.INI file in the C:\LSP directory to match the keywords contained in the sample PROTOCOL.INI file located at C:\INTEL\M32A as required (unless you are using PRO/100 CardBus adapter default settings).
- 16 Save the file and reboot the PC.

IBM PC LAN and IBM DOS LAN Requester

- 1 Install the IBM LAN Support Program according to the instructions under the heading “IBM Local Area Network Support Program,” which immediately precedes this one.
- 2 Reboot the PC.
- 3 Install IBM PC LAN or IBM DOS LAN Requester according to the instructions in the IBM documentation.
- 4 Reboot the PC.

Manual Installation

All network drivers provided on the Intel Network Drivers Disk can be installed manually, without the Intel Installation Program. You must copy the correct driver files to your hard disk and make appropriate changes to CONFIG.SYS, AUTOEXEC.BAT, and configuration files such as NET.CFG (for ODI) or PROTOCOL.INI (for NDIS). *Manual installation should only be performed by a system administrator or someone with equivalent knowledge of the installation process for your network operating system.*

NOTE:

For manual installation of Novell NetWare with VLM (available only under MS-DOS or Windows 3.x) you must first decompress the VLM files by running the MS-DOS batch file DCOMPVLM.BAT from the Network Drivers Disk, as follows:

```
DCOMPVLM [PATH]
```

where [path] is the directory for NetWare files (usually C:NWCLIENT). DCOMPVLM will decompress and copy all required files to the designated directory.

For an overview of the installation process, see the instructions provided for your network operating system in the alphabetical section of this chapter. Consult **Chapter 3, Configuration Reference**, for detailed information on configuration files and settings. For additional information, consult your network operating system documentation.

Microsoft LAN Manager

Microsoft LAN Manager (version 2.1)

NDIS 2.0 Driver

- 1 Run the Intel Installation Program from the Installation Disk.
- 2 Choose Microsoft LAN Manager from the Select Network Operating System screen.
- 3 Follow the prompts to complete the Intel segment of the installation.
- 4 Begin installation of LAN Manager using “setup.”
- 5 When prompted to select the available network adapter driver, choose “Other Driver.”

- 6 When prompted, insert the Intel Network Drivers Disk.
- 7 Select “Intel EtherExpress PRO/100 Mobile CardBus 32” from the menu.
- 8 Continue with the installation until it is completed.
- 9 If installing Microsoft LAN Manager to run under Windows proceed to step 10. Otherwise, skip to step 15.
- 10 Run Windows.
- 11 Choose setup from “Main” group.
- 12 Select Startup, and under the “Options” screen select Change System Settings.
- 13 Select Network then scroll to LAN Manager version 2.1.
- 14 Follow the prompts to complete the installation.
- 15 Reboot the PC.

Microsoft LAN Manager (version 2.1) with Windows for Workgroups 3.11

- 1 Run the Intel Installation Program from the Installation Disk.
- 2 Choose Windows for Workgroups from the Select Network Operating System screen.
- 3 Select “Yes” on the Attached to Network File Server screen.
- 4 Select Microsoft LAN Manager.
- 5 Follow the prompts to complete the Intel segment of the installation.
- 6 Start Windows and, in the Network program group, double-click on the Network Setup icon.
- 7 If you have not installed network support, choose Networks in the Network Setup dialog box, select Install Windows Network, and click OK. Otherwise proceed with step 8.
- 8 In the Network Setup dialog box, choose Drivers.
- 9 In the Network Drivers dialog box, choose Add Adapter.
- 10 In the Add Network Adapter box, choose Unlisted or Updated Network Adapter and click OK.
- 11 When prompted for an “unlisted, updated, or vendor-provided network driver disk,” insert the Intel Network Drivers Disk.
- 12 Select “**Intel M32A NDIS 2.01 Real Mode,**” and click OK.

- 13 Close the Network Drivers dialog box and click OK in the Network Setup box.
- 14 Complete the installation process, inserting the Intel Network Drivers Disk if required.
- 15 Continue with the installation until it is completed.
- 16 Click on the Control Panel in the “Main” group.
- 17 Select Startup from the Control Panel.
- 18 In the Options for Enterprise Networking window click “Log on to Windows NT or LAN Manager Domain.”
- 19 Save, exit, and reboot the PC.

Windows for Workgroups

NDIS 2.01 and ODI Drivers

Instructions are provided for installing Intel network drivers for the first time on a system using Windows for Workgroups version 3.11 alone or with NetWare. These instructions assume that Windows for Workgroups has already been installed. Remove any earlier version of the Intel drivers before installing the new version. No NDIS 3 driver is supplied for Windows for Workgroups.

The following topics are covered for Windows for Workgroups:

- How to install for Windows for Workgroups version 3.11 and NetWare using the ODI driver
- How to install for Windows for Workgroups 3.11 using the NDIS 2.0 driver
- How to Disable Windows for Workgroups Networking

For troubleshooting tips for Windows for Workgroups, see **Chapter 4, Troubleshooting**.

Windows for Workgroups Version 3.11 and NetWare (Using the ODI driver)

- 1 To configure Windows for Workgroups with NetWare, run the Intel Installation Program and choose Windows for Workgroups.
- 2 Choose YES to “Connect to Network Server.”
- 3 Choose “Novell NetWare” as your network server.
- 4 When the installation is complete, reboot the computer.
- 5 At the Intel menu, choose “Load EtherExpress PRO/100 Mobile CardBus 32 for Network Access.”
- 6 From the DOS prompt, run the NetWare Client install. Be sure to install support for Windows.
- 7 When the Novell Client install program asks for an ODI driver, insert the Intel Network Drivers Disk.
- 8 Complete the installation process and reboot the computer.
- 9 Log in to NetWare.
- 10 Start Windows for Workgroups and, in the Network program group, double-click on the Network Setup icon.

Windows for Workgroups Network Setup will detect the NetWare configuration and automatically select Novell NetWare as an additional network. It will also prompt for Novell support files (from Novell Client diskettes) if required during the installation. (If necessary, use the Novell decompression utility to decompress the required files.)

Windows for Workgroups Setup will also attempt to determine what NetWare driver model you are using. If for some reason Windows for Workgroups was unable to detect the driver model, you should select IPXODI and LSL as the driver type.

Note that you can install NetWare as an additional network under Windows for Workgroups, as follows:

- 11 In the Network Setup dialog box, choose Networks.
- 12 To install **both Windows for Workgroups and NetWare**, choose Install Windows Network.
- 13 Choose Other under Additional Network Support, then select the NetWare configuration appropriate for your network.
- 14 If you want to share your files or printers with others, select “Sharing.”

- 15 In the Network Setup dialog box, choose Drivers.
- 16 In the Network Drivers dialog box, choose Add Adapter.
- 17 In the Add Network Adapter box, choose Unlisted or Updated Network Adapter and click OK.
- 18 When prompted for an “unlisted, updated, or vendor-provided network driver disk,” insert the Intel Network Drivers Disk and click OK.
- 19 Select “**Intel EtherExpress PRO/100 Mobile CardBus 32**” and click OK.
- 20 Close the Network Drivers dialog box and click OK in the Network Setup box.
- 21 Complete the installation process, inserting the Intel Network Drivers Disk if required.
- 22 Reboot the computer.

NOTE:

Verify that the following lines have been added to your AUTOEXEC.BAT and STARTNET.BAT files. If they are not there, add them manually using a text editor.

Add the following command to the AUTOEXEC.BAT file, where WINDOWS is the directory into which Windows was installed:

```
C:\WINDOWS\NET START
```

Add the following command to the STARTNET.BAT file in your NWCLIENT directory, where \WINDOWS is the directory into which Windows was installed:

```
C:\WINDOWS\ODIHL.P.EXE
```

Windows for Workgroups 3.11 Using the NDIS 2.0 Driver

- 1 Run the Intel Installation Program from Disk 1, Installation Disk.
- 2 Choose Windows for Workgroups installation from the Select Network Operating System screen.
- 3 Choose “No” on the Attached to Network File Server screen.
- 4 Follow the prompts to complete the Intel segment of the installation.
- 5 Start Windows for Workgroups and double-click on the Network Setup icon in the Network Group.

- 6 If you have not installed network support, choose Networks in the Network Setup dialog box, select Install Windows Network, and click OK. Otherwise proceed to Step 7. Click the Sharing button to share files and printers.
- 7 In the Network Setup dialog box, choose Drivers.
- 8 In the Network Drivers dialog box, choose Add Adapter.
- 9 In the Add Network Adapter box, choose Unlisted or Updated Network Adapter and click OK.
- 10 When prompted for an “unlisted, updated, or vendor-provided network driver disk,” insert the Intel Network Drivers Disk.
- 11 Select “**Intel M32A NDIS 2.01 Real Mode**” and click OK.
- 12 Close the Network Drivers dialog box and click OK in the Network Setup box.
- 13 Complete the installation process, inserting the Intel Network Drivers Disk if required.

How to Remove an Existing Windows for Workgroups Installation

- 1 Start Windows and select Network Setup in the Network program group.
- 2 In the Network Setup dialog box, choose Drivers.
- 3 In the Network Drivers dialog box, choose Remove to discard any existing network adapter drivers.
- 4 Choose Close and return to the Network Setup dialog box.
- 5 Exit the Network Setup program and exit Windows.
- 6 At the DOS prompt, change to the Windows system directory, as follows

```
CD \WINDOWS\SYSTEM
```
- 7 Make a directory called OEM, as follows

```
MKDIR OEM
```
- 8 Type

```
DIR OEM?.INF
```

to see a list of driver configuration files.
- 9 Use the DOS EDIT program to view each OEM file to determine which ones reference Intel.
- 10 Copy the old Intel configuration files to the OEM directory.

- 11 Delete the old Intel configuration files from the Windows system directory.
- 12 Restart Windows.
- 13 Follow the instructions for installing drivers for Windows for Workgroups alone or Windows for Workgroups and NetWare.

Novell NetWare

ODI Driver

The Intel ODI driver allows for the concurrent use of Novell NetWare and other protocols that support Novell's Open Data-Link Interface (ODI) specification.

NetWare

- 1 Run the Intel Installation Program from the Installation Disk.
- 2 Choose Novell NetWare from the Select Network Operating System screen.
- 3 Follow the prompts to complete the installation.
- 4 The Intel Installation Program will reboot the computer and verify the NetWare connection.
- 5 Log in to the network.

NOTE:

The Intel Installation Program uses the NetWare VLM shell to connect to your NetWare server. The Installation Program decompresses and copies all the required files.

If you are installing manually, without the Intel Installation Program (under MS-DOS or Windows 3.x) you must first decompress the VLM files by running the MS-DOS batch file DCOMPVLM.BAT from the Network Drivers Disk, as follows:

```
DCOMPVLM [PATH]
```

where *[path]* is the directory for NetWare files (usually C:\NWCLIENT). DCOMPVLM will decompress and copy all required files to the designated directory.

If you need NETX shell support, contact your System Administrator.

SunSoft PC-NFS (version 3.5)

NDIS 2.0 Driver

- 1 Run the Intel Installation Program from the Installation Disk.
- 2 Choose SunSoft PC-NFS from the Select Network Operating System screen.
- 3 Follow the prompts to complete the Intel segment of the installation.
- 4 Install PC-NFS for Ethernet according to instructions in the PC-NFS documentation. Choose NDIS setup, and follow the instructions to complete the setup. Note the prompt that tells you that further manual modifications will have to be made.
- 5 Reboot the computer. You will see some error messages. Disregard them and continue with these instructions.
- 6 Rename the file PROTOCOL.NFS in the C:\LANMAN directory to PROTOCOL.INI. Use a text editor to edit the PROTOCOL.INI file as follows:

Replace the items

```
[YOUR-MAC-MODULE]
```

```
DRIVERNAME = YOURMAC$
```

```
OPTION1 = VALUE1 ETC.
```

```
[NFS-NDIS]
```

```
DRIVERNAME = NFSLINK1
```

```
BINDINGS = YOUR-MAC-MODULE
```

with

```
[INTELNET]
```

```
DRIVERNAME = INTEL$
```

```
[NFS-NDIS]
```

```
DRIVERNAME = NFSLINK$
```

```
BINDINGS = INTELNET
```

- 7 Copy M32ANDIS.EXE from the C:\INTEL\M32A directory to the C:\LANMAN directory.
- 8 Use a text editor to insert the following lines in your CONFIG.SYS file:

```
DEVICE=C:\LANMAN\M32ANDIS.EXE
```

between the two lines

```
DEVICE=C:\LANMAN\PROTMAN.SYS
```

```
DEVICE=C:\LANMAN\NFS-NDIS.SYS
```

as follows:

```
DEVICE=C:\LANMAN\PROTMAN.SYS
```

```
DEVICE=C:\LANMAN\M32ANDIS.EXE
```

```
DEVICE=C:\LANMAN\NFS-NDIS.SYS
```

- 9 Verify that your AUTOEXEC.BAT file contains a line that reads
`C:\LANMAN\NETBIND`

before the line that reads

```
NET INIT
```

- 10 Configure PC-NFS options according to your PC-NFS documentation, and reboot the computer.

Novell NetWare 32-bit ODI Drivers

Installing the Client 32 Driver under Windows 3.x and DOS

In order to install the Client 32 driver under Windows 3.x or DOS, the following software is needed:

- PRO/100 CardBus adapter Network Drivers Disk
- NetWare Client 32 for DOS/Win 3.1x disks from Novell

Installing under DOS

- 1 Put the NetWare Client 32 install disk in drive A.
- 2 Type `a:\install` and press enter.
- 3 Select the products you want to install.
- 4 Follow the onscreen instructions
- 5 At the Select a LAN Driver screen, select User Specified LAN Driver
- 6 Insert the Intel Network Drivers Disk in drive A
- 7 Type `A:` and press enter.
- 8 Select Intel EtherExpress PRO/100 CardBus Adapter

- 9** A screen will display the default settings for the driver. Most of the time, these settings do not need to be changed. Check the README.TXT for machine specific settings.
- 10** To complete installation, follow the onscreen instructions.

Installing under Windows 3.x

- 1** Select File, Run, and type a:\setup
- 2** Follow the onscreen instructions
- 3** When the ODI Driver Selection Dialog box appears, select User Specified Driver and click Next.
- 4** When prompted, insert the Intel Network Drivers Disk in drive A:
- 5** Select the driver a:\m32a.lan
- 6** To complete installation, follow the onscreen instructions.

Installing under Windows 95

Refer to the instructions on page 16.

Ungermann-Bass Net/One for DOS

NDIS 2.0 Driver

The PRO/100 CardBus adapter is supported on Ungermann-Bass Net/One LAN Manager and MS-NET networks. There are two NDIS driver packages available from UB: XNS BNS/NDIS and TCP BNS/NDIS. These packages, used with a Intel NDIS driver, provide files that support DOS workstations. They are available from UB and authorized UB representatives.

Ungermann-Bass Net/One LAN Manager version 2.1 Installation

- 1 Begin installation of LAN Manager 2.1 using “setup.”
- 2 When prompted to select the available network adapter driver, choose “Other Driver.”
- 3 When prompted, insert the Intel Network Drivers Disk.
- 4 Select “Intel EtherExpress PRO/100 Mobile CardBus 32” from the menu.
- 5 Continue with the installation until it is completed.
- 6 Following the UB instructions, modify your CONFIG.SYS file by adding the following lines:

For DOS:

```
DEVICE = [PATH]M32ANDIS.EXE
```

where *[path]* is the drive and directory in which you installed your network operating system.

- 7 Use a text editor to modify your PROTOCOL.INI file as follows:
 - For each protocol that you want to bind, set the protocol definition area of the PROTOCOL.INI file to:

```
BINDINGS = UBLOOP
```

- At the end of the file, add the following fragments:

```
[UBLOOP]
  DRIVERNAME = UBLOOP$
  BINDINGS = INTELNET
;INTEL ADAPTER
[INTELNET]
  DRIVERNAME = INTEL$
```

- 8 Reboot the PC.

Wollongong PathWay Access for DOS

NDIS and ODI Drivers

Wollongong PathWay Access for DOS can be installed using Intel NDIS or ODI drivers. Installation instructions for both types of driver are provided below. For information on which driver is appropriate for your network environment, refer to the Wollongong PathWay Access for DOS documentation.

Wollongong PathWay NDIS Installation

- 1 Run the Intel Installation Program from the Installation Disk.
- 2 Choose Wollongong PathWay Access from the Select Network Operating System screen.
- 3 Follow the prompts to complete the Intel segment of the installation.
- 4 Install PathWay Access for DOS Kernel and Drivers programs according to the instructions in the PathWay Access for DOS manual. Before rebooting the PC, continue with the following steps.
- 5 Use a text editor to modify the CONFIG.SYS file. After the statement that reads

```
DEVICE=C:\PATHWAY\PWTCP.SYS
```

add the lines

```
DEVICE=PATHWAY\[PROTMAN FILE] /I:C:\PATHWAY
DEVICE=PATHWAY\M32ANDIS.EXE
```

where [PROTMAN FILE] is equal to the PROTMAN2.EXE or PROTMAN.EXE file that is located in your PATHWAY directory. (Refer to the Wollongong PathWay Access for DOS manual for information regarding the differences between these two files.)

- 6 Copy the file M32ANDIS.EXE from C:\INTEL\M32A directory to the PATHWAY directory on your hard disk or boot disk.
- 7 Continue with the “custom” instructions in the PathWay Access for DOS manual.
- 8 Reboot the PC.

Wollongong PathWay ODI Installation

- 1 Run the Intel Installation Program from the Installation Disk.
- 2 Choose Wollongong PathWay Access from the Select Network Operating System screen.
- 3 Follow the prompts to complete the Intel segment of the installation.
- 4 Install PathWay Access for DOS Kernel and Drivers programs according to the instructions in the PathWay Access for DOS manual. Before rebooting the PC, perform the following steps.
- 5 Run the MS-DOS batch file DCOMPVLM.BAT from the Network Drivers Disk, as follows:

DCOMPVLM PATHWAY

DCOMPVLM.BAT will decompress and copy all required files from the Intel Network Drivers Disk to the PATHWAY directory on your hard disk or boot disk. (The files are LSL.COM, M32AODI.COM, IPXODI.COM, VLM.EXE, and NET.CFG.)

- 6 Change to the PATHWAY directory and load the software in the following order:

LSL

M32AODI

IPXODI (ONLY IF USING NOVELL NETWARE)

VLM (ONLY IF USING NOVELL NETWARE)

- 7 Load the Wollongong file ODI.EXE.
- 8 Continue with the instructions in the PathWay Access for DOS manual.
- 9 Reboot the PC.

Configuration Reference

Who Should Consult This Chapter?

This chapter contains additional information on PRO/100 CardBus adapter features and technical information on configuration requirements, including sample configuration files. You can use this information to modify an existing installation or perform a new installation manually without the assistance of the Intel Installation Program.

If You Installed with the Intel Installation Program

The file modifications made by the Intel Installation Program should allow most PC users to log on to their network after performing the steps outlined in **Chapter 1, Hardware Installation** and **Chapter 2, Software Installation**.

If you followed those instructions and still have not been able to successfully log on to your the network, you may need to modify the configuration parameters set by the Intel Installation Program. You can modify configuration settings by re-running the Intel Installation Program or by running IEDIT, the Intel System File Editor installed in the Intel Mobile Windows program group.

For Installation without the Intel Installation Program

The information in this chapter can be used to manually configure the PRO/100 CardBus adapter. For manual installation, it is assumed that you have some experience with manual setup of network adapters, and know how to access and modify configuration files, using an ASCII text editor. Intel recommends that manual installation be performed by a system administrator or equivalent.

Special Features

Card and Socket Services

The Personal Computer Memory Card International Association (PCMCIA) has developed specifications governing the use of PC Cards (formerly PCMCIA cards) in personal computer systems. The software components that implement these specifications are called Card and Socket Services. This software supports the ability of PC Card-aware device drivers (known as clients) to share cards, sockets, and system resources.

The PCMCIA has recently developed specifications for a new generation of 32-bit PC Cards, called CardBus. Since CardBus is new, support for CardBus has not yet been implemented in Card and Socket Services, although development is underway. To use Card and Socket Services with the PRO/100 CardBus adapter, the Card and Socket Services must support CardBus.

At press time, Intel had tested the following Card and Socket Services with the PRO/100 adapter:

Product/Operating System	Manufacturer
CardWizard v. 5.3/DOS/Windows 3.x	SystemSoft Corp.
Phoenix Card Manager 95 v. 4.0	Phoenix Technologies Ltd.

Intel is also working with the following vendors and products to ensure compatibility as they become available:

CardWare v. 5.0/Windows NT	Award Software International Inc.
CardWorks v. 5.3/Windows 95 (OSR2)	SystemSoft Corp.
CardWizard v. 3.0/Windows NT	SystemSoft Corp.
Card Executive/Windows NT	Phoenix Technologies Ltd.

As additional vendors add CardBus support to Card and Socket Services, new driver software from Intel may be required to use the Intel CardBus Adapter with Card and Socket Services. Review the README.TXT file and check the Intel website for the latest information.

Check with the vendor who supplied your Card and Socket Services to determine if it supports CardBus. If your Card and Socket Services do not support CardBus, the remainder of this section does not apply.

NOTE:

Microsoft Windows 95 and Windows NT have card handling functionality built-in and do not require separate Card and Socket Services software.

However, the first two releases of Windows 95 (versions 4.00.950 and 4.00.950a) did not include support for CardBus in Card and Socket Services. Windows 95 Release OSR2 (also referred to as version 4.00.950b) includes CardBus support. See the Windows 95 Installation section at the beginning of Chapter 2 for additional details.

If you are using the OSR2 version of Windows 95, the information in this section is applicable. Windows NT 3.51 and 4.0 do not implement native CardBus support. Please refer to the Windows NT Installation section at the beginning of Chapter 2 for additional information.

Finally, review the README.TXT file or the Intel website for the latest information on support for CardBus under various operating systems and Card and Socket Services.

If you are using the version of Windows 95 that supports CardBus, you can take advantage of the full range and benefits of PC Card capability. If you are not using that version of Windows 95, the features following the note may not be supported.

NOTE:

For DOS and Windows 3.1 systems, the Intel PRO/100 CardBus driver may be able to co-exist with older Card and Socket Services, even though the Card and Socket Services do not directly support CardBus. Consult the installation instructions in Chapter 2 and README.TXT file for more details.

HotSwap

The PRO/100 CardBus adapter currently supports HotSwap during connection to a network or host computer from a CardBus computer *only* if you are running versions of Windows 95 or Windows NT that fully support CardBus. This feature allows the CardBus to be removed from the computer, temporarily replaced with another type of card such as a modem or memory card, then reinserted without loss of network connection.

For example, a user could replace a PRO/100 CardBus adapter connected to a network with a PC Card flash or SRAM memory card. The network drives become temporarily inaccessible. Any access from DOS or Windows will return an “Invalid drive specification” message. Meanwhile, the drive associated with the flash or SRAM card is available for copying and data retrieval.

If the PRO/100 CardBus is returned to the PC Card slot within the timeout period specified by the network operating system, then network drives, path, and mappings will be reinstated exactly as they were before the swap. The default timeout value varies for different network operating systems. On NetWare 3.11, for example, the default setting is 15 minutes and is modifiable only by the network administrator. If the 15 minute limit is exceeded, the network connection can usually be restored by simply logging back in without rebooting.

NOTE:

The HotSwap feature is not supported unless Card and Socket Services software (or its equivalent under Windows 95 or Windows NT) supports CardBus and is running on the PC Card computer. Upgrading to new drivers from Intel may also be required, as new Card and Socket software is released.

Power Management Suspend/Resume

Power management features such as suspend/resume are supported by the PRO/100 CardBus adapter on PC Card systems running both Card and Socket Services (or the equivalent functionality of Windows 95 or Windows NT) that support CardBus. This means that when the computer enters a reduced power or power saving mode, an ongoing network connection will remain active for the period of time allowed by the network operating system. Even if the time period is exceeded, the network connection can usually be restored by simply logging back in without rebooting.

NOTE:

The suspend/resume feature is not supported unless Card and Socket Services software (or its equivalent under Windows 95 or Windows NT) supports CardBus and is running on the PC Card computer.

Power Management Guidelines

HotSwap and suspend/resume operations are subject to limitations dictated by the network operating system. See the documentation for your network operating system to determine how long the network will wait for activity before dropping a connection, and whether this time period is user configurable.

Full-Duplex Transmission

The PRO/100 CardBus adapter hardware and network drivers are designed to support full-duplex operation, or the ability to transmit and receive on the network at the same time. This feature is only available when the Adapter is connected to full-duplex switches.

If your network supports full-duplex operation, activate the CardBus feature by including the keyword `LINEMODE=FULL` in the configuration file or on the command line for your network driver.

NOTE:

To use full-duplex capabilities, your network must have full-duplex hardware in place and enabled. If you use the `LINEMODE=FULL` keyword without full-duplex hardware, the network will become unusable due to excessive collisions.

Advanced Look-Ahead Pipelining

The PRO/100 CardBus adapter also uses pipelining technology to improve performance. Advanced Look-Ahead Pipelining allows for processing and transmission of packets before the entire packet has been loaded into memory, resulting in significant gains in performance. This feature is enabled automatically, without user intervention.

Memory Exclusion

When using a memory manager (under DOS and Windows 3.X), you must exclude a 4K memory range between C000 and EF00 for the use of the PRO/100 CardBus adapter. For example:

```
DEVICE=C:\DOS\HIMEM.SYS
DEVICE=C:\DOS\EMM386.EXE NOEMS X=D200-D2FF
```

This example excludes 4K of the D200 segment for use by the PRO/100 CardBus adapter. If the CardBus software is not configured for a specific address, it will automatically detect a free memory range. Otherwise, be sure the CardBus software is set to the same memory window that is excluded.

Sample Configuration Files for Selected Network Operating Systems

The following sample configuration files show default parameters for some network operating systems. This information is designed to supplement the information provided in **Chapter 2, Software Installation**.

Artisoft LANtastic/II 6.0

NOTE:

If you are using DOS multi-menu CONFIG.SYS, the three LANtastic-related lines in the CONFIG.SYS will be located in a COMMON section at the end of your CONFIG.SYS. You will have to manually move those lines into the proper menuitem section of your CONFIG.SYS. The same is true for the line call c:\lantastilstartnet.bat in your AUTOEXEC.BAT file.

Sample CONFIG.SYS

```
device=c:\dos\himem.sys
REM INTEL PRO/100 CB - DO NOT CHANGE LINES BELOW
DEVICE=C:\DOS\EMM386.EXE NOEMS X=D200-D2FF
REM DEVICE=C:\DOS\EMM386.EXE NOEMS
REM INTEL PRO/100 CB - DO NOT CHANGE LINES ABOVE
```

```
FILES=50
BUFFERS=30
REM INTEL PRO/100 CB — DO NOT CHANGE LINES BELOW
DEVICE=C:\LANTASTI\PROTMAN.DOS /I:C:\LANTASTI
DEVICE=C:\LANTASTI\M32ANDIS.EXE
REM INTEL PRO/100 CB — DO NOT CHANGE LINES ABOVE
```

Sample AUTOEXEC.BAT

```
PATH=C:\UTIL;C:\DOS;
PROMPT $P$G
CALL C:\LANTASTI\STARTNET.BAT
```

Sample PROTOCOL.INI

```
;PROTOCOL.INI FOR LANTASTIC VERSION 6.00
;———— USING INTEL ETHEREXPRESS PRO/100 32-BIT
;MOBILE ADAPTER
;
[PROTMAN]
DRIVERNAME = PROTMAN$
DYNAMIC = YES
; PROTOCOL.INI SECTION FOR THE INTEL ETHEREXPRESS
;PRO/100 32-BIT MOBILE ADAPTER.
[M32ANDIS_NIF]
DRIVERNAME = INTEL$
NOEARLYRX
```

Sample STARTNET.BAT

```
@ECHO OFF
REM LANTASTIC VERSION 6.00 INSTALLED 95/01/26
11:31:28
REM (FOR DOS)
C:
CD C:\LANTASTI
SET LAN_CFG=C:\LANTASTI
```

```
REM IF LANTASTIC IS DISABLED, SKIP EVERYTHING.
IF EXIST DISABLED GOTO :STARTNET_DONE
@ECHO ===== BEGIN LANTASTIC CONFIGURATION =====
PATH C:\LANTASTI;%PATH%
SET LAN_DIR=C:\LANTASTI.NET
LOADHIGH AI-NDIS BIND_TO=M32ANDIS_NIF
AILANBIO @STARTNET.CFG
REDIR T4700 @STARTNET.CFG
IF EXIST NOSHARE GOTO :NOSHARE
SERVER C:\LANTASTI.NET @STARTNET.CFG
NET LOGIN \\T4700
GOTO :CONTINUE
:NOSHARE
@ECHO LANTASTIC SERVER WAS INSTALLED BUT TURNED
OFF.
:CONTINUE
REM IF CONNECT.BAT EXISTS, RUN IT TO SET UP
CONNECTIONS.
IF EXIST CONNECT.BAT GOTO :CONNECT
REM OTHERWISE SET UP CONNECTIONS SPECIFIED DURING
INSTALL.
NET USE LPT1: \\T4700\@PRINTER
NET LPT TIMEOUT 10
GOTO :CONNECT_DONE
:CONNECT
@ECHO SETTING UP LANTASTIC CONNECTIONS FROM
CONNECT.BAT
REM BUILD CONNECT.BAT LIKE THIS: "NET SHOW/BATCH
>C:\LANTASTI\CONNECT.BAT"
REM (OR RUN THE BATCH FILE SETNET.BAT)
CALL CONNECT.BAT
:CONNECT_DONE
NET POSTBOX
```

```
@ECHO ===== END LANTASTIC CONFIGURATION =====
:STARTNET_DONE
CD \
```

Banyan VINES

NOTE:

If you are using DOS Multi-menu CONFIG.SYS, the three VINES related lines in the CONFIG.SYS will be located at the end of your CONFIG.SYS. You will have to manually move those lines into the proper menuitem section of your CONFIG.SYS. If you are getting Banyan VINES Error codes 10xx, check your C:\VINES\NDISBAN.DOC for explanations of error codes.

Sample CONFIG.SYS

```
DEVICE=C:\DOS\HIMEM.SYS
REM INTEL PRO/100 CB - DO NOT CHANGE LINES BELOW (EMM)
DEVICE=C:\DOS\EMM386.EXE NOEMS X=D200-D2FF
REM DEVICE=C:\DOS\EMM386.EXE NOEMS
REM INTEL PRO/100 CB - DO NOT CHANGE LINES ABOVE
FILES=40
BUFFERS=30
REM INTEL PRO/100 CB - DO NOT CHANGE LINES BELOW (NDIS)
DEVICE=C:\VINES\PROTMAN.DOS /I:C:\VINES
DEVICE=C:\VINES\M32ANDIS.EXE
REM INTEL PRO/100 CB - DO NOT CHANGE LINES ABOVE
```

Sample AUTOEXEC.BAT

```
PATH=C:\UTIL;C:\DOS;
PROMPT $P$G
CD\VINES
BAN
```

Sample PROTOCOL.INI

```
; PROTOCOL.INI SECTION FOR THE INTEL ETHEREXPRESS
;PRO/100 32-BIT MOBILE ADAPTER.
```

[INTELNET]

DRIVERNAME = INTEL\$

DEC PATHWORKS 5.0 and 5.1

Sample CONFIG.SYS

```
DEVICE=C:\DOS\HIMEM.SYS
DEVICE=C:\DOS\EMM386.EXE NOEMS X=D200-D2FF
FILES=40
BUFFERS=30
SHELL=C:\DOS\COMMAND.COM /P /E:1024
LASTDRIVE=G
```

Sample AUTOEXEC.BAT

```
CD\PW
STARTNET.BAT
```

Sample PROTOCOL.INI (after completion of install process)

```
[PROTOCOL MANAGER]
DRIVERNAME = PROTMAN$

[IPX4MAC]
DRIVER = IPX$MAC
BINDINGS = M32ANDIS

[IPX_XIF]
DRIVERNAME = IPX$
BINDINGS = M32ANDIS

[NETBEUI]
DRIVERNAME = NETBEUI$
SESSIONS = 6
NCBS = 12
BINDINGS = M32ANDIS
```

```
LANABASE = 0
[DATA LINK]
DRIVERNAME = DLL$MAC
LG_BUFFERS = 14
SM_BUFFERS = 6
OUTSTANDING = 32
BINDINGS = M32ANDIS
DECPARM = C:\PW\
IRQ = 5
;; YOUR DECNET ADDRESS IS AA0004008407
;;
[M32ANDIS]
DRIVERNAME=INTEL$
```

Windows for Workgroups 3.11

Sample CONFIG.SYS

```
DEVICE=C:\DOS\HIMEM.SYS
REM INTEL PRO/100 CB - DO NOT CHANGE LINES BELOW
(EMM)
DEVICE=C:\DOS\EMM386.EXE NOEMS X=D200-D2FF
REM DEVICE=C:\DOS\EMM386.EXE NOEMS
REM INTEL PRO/100 CB - DO NOT CHANGE LINES ABOVE
FILES=40
BUFFERS=30
DEVICE=C:\WINDOWS\IFSHLP.SYS
LASTDRIVE=Z
```

Sample AUTOEXEC.BAT

C:\WINDOWS\NET START

Sample PROTOCOL.INI

```
[NETWORK.SETUP]
VERSION=0X3110
NETCARD=M32AMAC,1,M32AMAC,1
TRANSPORT=MS$NETBEUI,NETBEUI
TRANSPORT=MS$NDISHLP,MS$NDISHLP
LANA0=M32AMAC,1,MS$NETBEUI
LANA1=M32AMAC,1,MS$NDISHLP

[NETBEUI]
BINDINGS=M32AMAC,ASYMAC
LANABASE=0
DRIVERNAME=NETBEUI$
SESSIONS=10
NCBS=12

[PROTMAN]
DRIVERNAME=PROTMAN$
PRIORITY=MS$NDISHLP

[M32AMAC]
DRIVERNAME=INTEL$

[MS$NDISHLP]
DRIVERNAME=NDISHLP$
BINDINGS=M32AMAC
```

Sample [NETWORK DRIVERS] SECTION IN SYSTEM.INI

```
[NETWORK DRIVERS]
DEVDIR=C:\WINDOWS
LOADRMDRIVERS=YES
```



```
NETCARD=M32ANDIS.EXE
TRANSPORT=*NETBEUI,NDISHLP.SYS
```

Windows for Workgroups Using the ODI Driver with NetWare as Secondary Network

Sample STARTNET.BAT

```
REM INTEL PRO/100 CB - DO NOT CHANGE LINES BELOW
:M32A_MENU
@ECHO OFF
CLS
GOTO %CONFIG%
:M32A_E_INTEL
C:
CD C:\NWCLIENT
IF NOT EXIST M32AODI.COM GOTO M32A_ERROR
LSL
M32AODI.COM
IPXODI
C:\WINDOWS\ODIHLP.EXE
VLM
IF NOT EXIST ICHECK.EXE GOTO S_M32A_INTEL
CLS
ICHECK.EXE -E -1 F:
:S_M32A_INTEL
F:
LOGIN
GOTO M32A_END
:M32A_ERROR
ECHO ERROR: UNABLE TO LOCATE DRIVER FILE.
:M32A_END
C:
```

CD \

REM INTEL PRO/100 CB - DO NOT CHANGE LINES ABOVE

Sample CONFIG.SYS

REM INTEL PRO/100 CB - DO NOT CHANGE LINES
BELOW (MENU)

[MENU]

MENUIITEM=M32A_E_INTEL,LOAD INTEL
ETHEREXPRESS PRO/100 32-BIT MOBILE ADAPTER
FOR NETWORK ACCESS

MENUIITEM=M32A_END,DO NOT LOAD ANY INTEL
DRIVERS

MENUCOLOR=15,0

[M32A_E_INTEL]

[M32A_END]

[COMMON]

REM INTEL PRO/100 CB - DO NOT CHANGE LINES
ABOVE

DEVICE=C:\WINDOWS\HIMEM.SYS /TESTMEM:OFF

DEVICE=C:\DOS\EMM386.EXE X=D000-DFFF

DOS=HIGH

DOS=UMB

BUFFERS=20

FILES=40

LASTDRIVE=Z

DEVICE=C:\WINDOWS\IFSHLP.SYS

STACKS=9,256

Sample AUTOEXEC.BAT

@ECHO OFF

PROMPT \$P\$G

PATH C:\WINDOWS;C:\DOS

```
SET TEMP=C:\DOS
C:\DOS\SMARTDRV.EXE /X C+

REM INTEL PRO/100 CB - DO NOT CHANGE LINES
BELOW
:M32A_MENU
@ECHO OFF
CLS
GOTO %CONFIG%
:M32A_E_INTEL
C:\WINDOWS\NET START
C:
CD C:\NWCLIENT
IF NOT EXIST C:\NWCLIENT\STARTNET.BAT GOTO
M32A_ERROR
CALL C:\NWCLIENT\STARTNET.BAT
GOTO M32A_END
:M32A_ERROR
ECHO ERROR: UNABLE TO LOCATE DRIVER FILE.
:M32A_END
C:
CD \
REM INTEL PRO/100 CB - DO NOT CHANGE LINES
ABOVE
REM INTEL PRO/100 CB - DO NOT CHANGE LINES
BELOW (PATH)
PATH=%PATH%;C:\NWCLIENT
REM INTEL PRO/100 CB - DO NOT CHANGE LINES
ABOVE
```

Sample PROTOCOL.INI

```
[NETWORK.SETUP]
VERSION=0X3110
```

```
NETCARD=M32A$ODI,1,M32A$ODI,4
TRANSPORT=MS$NWLINKNB,NWLINK
TRANSPORT=MS$NETBEUI,NETBEUI
LANA0=M32A$ODI,1,MS$NETBEUI
LANA1=M32A$ODI,1,MS$NWLINKNB
```

```
[NET.CFG]
```

```
PATH=C:\NWCLIENT\NET.CFG
```

```
[M32A$ODI]
```

```
[LINK DRIVER M32AODI]
```

```
DATA=FRAME ETHERNET_802.2
```

```
[NWLINK]
```

```
BINDINGS=M32AODI
```

```
[NETBEUI]
```

```
BINDINGS=M32AODI
```

```
LANABASE=0
```

```
SESSIONS=10
```

```
NCBS=12
```

Sample [network drivers] section in SYSTEM.INI

```
[NETWORK DRIVERS]
```

```
DEVDIR=C:\WINDOWS
```

```
LOADRMDRIVERS=NO
```

Sample NET.CFG file (located C:\NWCLIENT)

```
LINK DRIVER M32AODI
```

```
FRAME ETHERNET_802.3
```

```
FRAME ETHERNET_802.2
```

```
FRAME ETHERNET_II
```

```
FRAME ETHERNET_SNAP
```

Driver Parameters Reference

The following paragraphs present configuration guidelines for each of the driver types: NDIS2 and NDIS3, ODI, and packet. These guidelines are followed by a comprehensive “keyword” reference section.

All of the drivers described here automatically detect the speed of the network to which the adapter is attached (10 Mbps or 100 Mbps), unless otherwise noted. Speed can also be specified with the `LINESPEED` keyword.

Full-duplex operation must be explicitly configured with the `LINEMODE` keyword, unless the adapter is being connected to a hub which supports Nway* auto-negotiation. In this case the adapter will auto-detect full-duplex operation.

All of the DOS drivers have enhanced resource detection capability built in. The drivers will detect free system memory, IRQ, and I/O resources for use by the drivers. To use this feature, do not force a particular resource by placing a keyword in the network configuration file. This will override the automatic resource detection for that parameter.

ODI Settings (for driver M32AODI.COM and M32AODI.OS2)

Custom parameters for networks using the ODI driver can be entered manually, using an ASCII editor, in the `NET.CFG` file.

DOS ODI Driver Configuration Notes (M32AODI.COM)

The ODI driver `M32AODI.COM` conforms to the “Novell ODI Specification: 16-bit DOS Client HSMs.” It is a DOS-based terminate-and-stay-resident (TSR) program. The driver will configure itself according to the options specified in the `NET.CFG` file. This file is supplied on the Network Drivers Disk and must be present in the same directory as the ODI driver. Files required for using `M32AODI.COM` are

<code>M32AODI.INS</code>	Intel installation information file
<code>NET.CFG</code>	Network configuration file
<code>M32AODI.COM</code>	Intel ODI driver

Most installations will be able to use the settings implemented in the NET.CFG file by the Intel Installation Program. If any parameters need to be changed, use an ASCII text editor to open and modify the NET.CFG file and insert the appropriate keywords and values after the line

```
LINK DRIVER M32AODI
```

Parameters can also be implemented on the command line. Command line parameters override parameters placed in the NET.CFG file.

NET.CFG Example

```
LINK DRIVER M32AODI
FRAME ETHERNET_802.2
```

M32AODI.COM Keywords

KEYWORD	DEFAULT	VALID VALUES
MEMORY	AUTO	C000 - EF00
IOADDRESS	AUTO	100 - FF80
IRQ	AUTO	3-15
SOCKET	AUTO	1-4
MODE	MEM	IO OR MEM
NOCHECK	NOT PRESENT	
NOLED	NOT PRESENT	
TXBUFFERSIZE	2	1 - 10
RXBUFFERSIZE	15	1 - 30
ERT	HIGH	LOW, MED, OR HIGH
NOEARLYRX	NOT PRESENT	
NOEARLYTX	NOT PRESENT	
LINESPEED	AUTO	10 OR 100
LINEMODE	AUTO	HALF OR FULL
LINKDISABLE	NOT PRESENT	
NOBURST	NOT PRESENT	
LATENCY	32	0 - 255
CACHE	8	0, 4, 8, 16, 32
NOWRITEPOST	NOT PRESENT	

NOPREFETCH**NOT PRESENT****S****(COMMAND LINE ONLY: SHOW
RESIDENT LAN DRIVERS)****U****(COMMAND LINE ONLY: UNLOAD)**

OS/2 ODI Driver Configuration Notes (CBEODI.OS2)

The OS/2 ODI driver M32AODI.OS2 conforms to the Novell "ODI Developer's Guide for OS/2 Client Driver Hardware Specific Modules" version 2.1. It is an IBM OS/2-based device driver for use with OS/2 versions 2.0 and later. The Novell OS/2 workstation ODI stack including M32AODI.OS2 supports Novell's NetWare Requester for OS/2 networking client environment.

Files required for using M32AODI.OS2 include Novell OS/2 Requester files and the following files:

NET.CFG

Network configuration file

M32AODI.OS2

Intel ODI driver for OS/2

Most installations will be able to use the settings implemented in the NET.CFG file by the Intel Installation Program. If any parameters need to be changed, use an ASCII text editor to open and modify the NET.CFG file and insert the appropriate keywords and values after the line

LINK DRIVER M32AODI

NDIS 2.0.1 Settings (for drivers M32ANDIS.EXE and M32ANDIS.OS2)

Custom parameters for the NDIS driver can be entered manually, using an ASCII editor, in the **PROTOCOL.INI** file.

NDIS 2.0.1 DOS Driver Configuration Notes

The DOS NDIS driver **M32ANDIS.EXE** conforms to the 3Com/Microsoft LAN Manager Network Driver Interface Specification (NDIS) version 2.0.1. It is a DOS-based executable terminate-and-stay-resident (TSR) program that will configure itself according to the options specified in the **PROTOCOL.INI** file, which is supplied on the Network Drivers Disk.

The files required for using **M32ANDIS.EXE** are:

PROTOCOL.INI	Configuration and binding information file
M32ADOS.NIF	Intel installation file for Microsoft LAN Manager
M32ANDIS.EXE	Intel DOS NDIS 2.0.1 driver

NDIS 2.0.1 OS/2 Driver Configuration Notes

The OS/2 NDIS driver **M32ANDIS.OS2** conforms to the 3Com/Microsoft LAN Manager Network Driver Interface Specification (NDIS) version 2.0.1. It is an IBM OS/2-based device driver for use with OS/2 versions 2.0 and later.

The files required for using **M32ANDIS.OS2** are:

PROTOCOL.INI	Configuration and binding information file
M32AOS2.NIF	Intel installation file for Microsoft LAN Manager
M32ANDIS.OS2	Intel OS/2 NDIS 2.0.1 driver

If any parameters need to be changed, use an ASCII text editor to modify the **PROTOCOL.INI** file with the appropriate keywords and values.

Keyword syntax for **PROTOCOL.INI** can be found below. Keywords are not case sensitive, and can be abbreviated to a unique sequence of initial characters (for example, **IN** for **INTERRUPT**, **IO** for **IOADDRESS**). A Keyword Alphabetical Reference follows the keyword listings.

Most installations will be able to use the settings implemented in the **PROTOCOL.INI** file by the Intel Installation Program. If any parameters need to be changed, use an ASCII text editor to modify the **PROTOCOL.INI** file with the appropriate keywords and values.

NDIS 2.0.1 Keywords (M32ANDIS.EXE and M32ANDIS.OS2)

KEYWORD	DEFAULT	VALID VALUES
DRIVERNAME=INTEL\$	(REQUIRED FIRST ITEM IN PROTOCOL.INI)	
MEMORY	AUTO	C000 - EF00
IOADDRESS	AUTO	100 - FF80
IRQ	AUTO	3 - 15
SOCKET	AUTO	1 - 4
MODE	MEM	IO OR MEM
NOCHECK	NOT PRESENT	
NOLED	NOT PRESENT	
TXBUFFERSIZE	2	1 - 10
RXBUFFERSIZE	15	1 - 30
ERT	HIGH	LOW, MEDIUM, HIGH
NOEARLYRX	NOT PRESENT	
NOEARLYTX	NOT PRESENT	
LINESPEED	AUTO	10 OR 100
LINEMODE	AUTO	HALF OR FULL
LINKDISABLE	NOT PRESENT	
NOBURST	NOT PRESENT	
LATENCY	32	0 - 255
CACHE	32	0, 4, 8, 16, OR 32
NOWRITEPOST	NOT PRESENT	
NOPREFETCH	NOT PRESENT	
VERBOSE	NOT PRESENT	

M32A.SYS (NDIS 3) Settings for Microsoft Windows NT and Windows 95

M32A.SYS is an NDIS 3 Miniport driver. It conforms to the Microsoft Network Driver Interface Specification (NDIS). It supports both Windows NT and Windows 95.

Windows NT Support

The M32A.SYS driver supports the networking environment in Microsoft Windows NT versions 3.51 and greater.

The files necessary for using M32A.SYS include:

M32A.DLL	Intel M32A installation DLL
OEMSETNT.INF	Intel installation file for Microsoft Windows NT
M32A.SYS	Intel NDIS 3 driver for Microsoft Windows NT

There are user-configurable parameters to the M32A.SYS driver which can be modified using the Network Control Panel built into Windows NT. This applet uses the OEMSETNT.INF file to set the corresponding parameters in the registry.

The user-configurable parameters are as follows:

Parameter	Default	Valid Values	Registry Value
I/O PORT	0XF800	0X1000-0XF800	SAME
MEMORY ADDRESS	0XD4000	0XC0000-0XDF000	SAME
INTERRUPT	5	3, 4, 5, 7, 10, 11, 15	SAME
INTERRUPT STYLE	0	AUTO DETECT	0
		PCI IRQS	1
		ISA IRQS	2
LINE SPEED	0	AUTODETECT	0
		10 MB	1
		100 MB	2
LINE MODE	1	AUTODETECT	0
		HALF-DUPLEX	1
		FULL-DUPLEX	2
PC CARD SOCKET	0	AUTODETECT	0
		1	1
		2	2
		3	3
DIRECT ENABLE	0	AUTODETECT	0
		OFF	1
		ON	2
EARLYTRANSMIT	1	OFF	0
		ON	1
EARLYRECEIVE	1	OFF	0
		ON	1

The network node address can be modified by manually editing the registry and adding the parameter 'NetworkAddress' with a hexadecimal string value, such as '00A0C9112233'. If the user does NOT specify a 'NetworkAddress' then the M32A.SYS driver uses the network node address contained in the PRO/100 CardBus adapter Card Information Structure.

Windows 95 Support

The M32A.SYS driver also supports the networking environment in Microsoft Windows 95.

The files necessary for using M32A.SYS with Windows 95 include:

- NETM32A.INF Intel installation file for Windows 95
- M32A.SYS Intel NDIS 3 driver for Windows 95

There are user-configurable parameters to the M32A.SYS driver which can be modified using the Network Control Panel built into Windows 95. This applet queries the user for parameter selections and then sets the corresponding parameters in the registry. The user-configurable parameters are as follows:

Parameter Value	Default Valid	Values	Registry
DIRECTENABLE	AUTODETECT	OFF, ON, AUTODETCT	0
EARLYTRANSMIT	ON	OFF, ON	0, 1
LINESPEED	AUTO	AUTO DETECT, 10 MBPS, 100 MBPS	0, 1, 2
LINEMODE	0	AUTODETCT, HALF-DUPLEX, FULL-DUPLEX	0, 1, 2
INTERRUPTSYTLE	0	AUTODETECT, PCI-IRQ, ISA-IRQ	0, 1, 2

SOCKET	0	AUTODETECT	0
		1	1
		2	2
		3	3
		4	4

The network node address can be modified by specifying a value for 'NetworkAddress' such as '00A0C9112233'. If the user does NOT specify a 'NetworkAddress' then the M32A.SYS driver uses the network node address contained in the PRO/100 CardBus adapter Card Information Structure.

Novell Client 32 Driver Settings (for driver M32A.LAN)

The driver M32A.LAN conforms to the Novell "ODI NetWare Server Driver Development Tool Kit Driver Specification" version 3.3. It is a 32-bit driver. This driver can be used as a server driver in NetWare versions 3.12, 4.10, and 4.11. For NetWare 3.12 and 4.10, server NLMs must be updated to the 3.3 specification. The new NLMs can be obtained from Novell.

Novell Client32 Driver Keywords

Parameters for configuring the Novell server driver must be specified on the command line.

Keyword	Default	Valid Values
MEMORY	AUTO	C000 - FFFFE000
IOADDRESS	AUTO	100 - FF80
IRQ	AUTO	3 - 15
SOCKET	AUTO	1 - 4
MODE	MEM	IO or MEM
NOLED	NOT PRESENT	
TXBUFFERSIZE	10	1 - 100
RXBUFFERSIZE	30	1 - 100

ERT	HIGH	LOW, MEDIUM, or HIGH
NOEARLYRX	NOT PRESENT	
NOEARLYTX	NOT PRESENT	
LINESPEED	AUTO	10 or 100
LINEMODE	HALF	HALF or FULL
LINKDISABLE	NOT PRESENT	
NOBURST	NOT PRESENT	
LATENCY	32	0 - 255
CACHE	32	0, 4, 8, 16, or 32
NOWRITEPOST	NOT PRESENT	
NOPREFETCH	NOT PRESENT	

Packet Driver Settings (for driver M32APD.COM)

Packet driver parameters must be stated on the **M32APD.COM** command line when running the packet driver.

Packet Driver Configuration Notes

The Intel packet driver M32APD.COM conforms to FTP Software's public domain packet-driver specification. It is a DOS-based terminate-and-stay-resident (TSR) program. The driver file M32APD.COM is located in the \PKTDRV directory on the Network Drivers Disk.

Refer to your network documentation for instructions on how to install the packet driver with your network. Most installations should be able to use the default settings listed below.

Keywords are not case sensitive, and can be abbreviated to a unique sequence of initial characters (for example, IN for INTERRUPT).

Packet Driver Keywords

Keyword	Default	Valid Values
MEMORY	AUTO	C000 - EF00
IOADDRESS	AUTO	100 - FF80
IRQ	AUTO	3 - 15
SOCKET	AUTO	1 - 4
MODE	MEM	IO OR MEM
NOCHECK	NOT PRESENT	
NOLED	NOT PRESENT	
TXBUFFERSIZE	2	1 - 10
RXBUFFERSIZE	15	1 - 30
ERT	HIGH	LOW, MEDIUM, OR HIGH
NOEARLYRX	NOT PRESENT	
NOEARLYTX	NOT PRESENT	
LINESPEED	AUTO	10 OR 100
LINEMODE	HALF	HALF OR FULL

LINKDISABLE	NOT PRESENT	
NOBURST	NOT PRESENT	
LATENCY	32	0 - 255
CACHE	32	0, 4, 8, 16, OR 32
NOWRITEPOST	NOT PRESENT	
NOPREFETCH	NOT PRESENT	
SINT	60	(60 - 80)
VERBOSE	NOT PRESENT	

Packet Driver Example

A typical sequence for loading the packet driver M32APD.COM and default configuration settings is as follows:

```
M32APD
ETHDRV
```

If no default configuration settings are used, these must be stated on the M32APD.COM command line. For example,

```
M32APD IOADDRESS=320 INT=7
ETHDRV
```

Diagnostic Test Utility Settings (M32ATEST.EXE)

The M32ATEST.EXE utility is a Intel utility for testing Intel adapter hardware. It is an MS-DOS executable file.

M32ATEST.EXE tests the adapter hardware functionality, including the PC Card interface, the serial EEPROM, the Ethernet controller, and the PHY interface (adapter modules). It displays manufacturing information including serial number and date and time of manufacture. It also displays configuration information including interrupt, I/O address, and starting memory location used.

M32ATEST.EXE is an interactive program. It does not take command line parameters. Parameters can be modified and tested through the user interface in the program. See the Troubleshooting section for more information about this utility.

Keyword Alphabetical Reference

- ?** displays command summary for driver
- CACHE** sets the system cache line size on the CardBus Bridge. Valid arguments are system dependent and may include only 0 (cache disabled), 4, 8, 16, or 32. Changing this parameter may affect network performance.
- DIRECTENABLE** **For 32-bit NDIS3 Driver (M32A.SYS) only:** DIRECTENABLE forces the method used by the driver to determine if a PRO/100 CardBus adapter is present. Valid parameters are AutoDetect, Off, and On. Using AutoDetect allows the driver to determine if the CardBus bridge has already been setup by another enabler such as a Socket and Card Services. If so, the driver will use the current configuration. Using On, forces the driver to enable the CardBus bridge without checking its current state.
- DRIVERNAME=INTEL\$** required as first item in the INTEL section of the PROTOCOL.INI file for the M32ANDIS driver.
- ERT** specifies the Advanced Look-ahead Pipelining threshold. Valid settings are LOW, MEDIUM, and HIGH. Changing this value will affect network performance, depending on the computer system.
- INT** See IRQ.
- INTERRUPT** See IRQ.
- INTERRUPTSTYLE** **For 32-bit NDIS3 Driver (M32A.SYS) only:** INTERRUPTSTYLE forces the driver to use ISA IRQ routing or PCI IRQ routing. Some CardBus bridges have the capability of supporting both PCI and ISA style IRQ routing. Valid parameters are AutoDetect, PCI-IRQ, and ISA-IRQ. The default keyword is AutoDetect.
- IOADDRESS and IOBASEADDRESS** specifies the base I/O address of the Intel adapter I/O ports, in hexadecimal notation. The PRO/100 CardBus adapter requires 128 contiguous I/O addresses if run in I/O mode. If using memory-mapped I/O mode, no I/O ports are necessary. If this parameter is not specified the driver will detect an I/O port automatically.

I/O PORT

see IOADDRESS

IRQ

specifies a hardware interrupt for use by the adapter. If the computer system uses PCI interrupts on the CardBus Bridge, this parameter is ignored (unless the ISAIRQ keyword is used as an override). If this parameter is not specified the driver will detect an IRQ automatically.

ISAIRQ

use this keyword to force the driver to use ISA IRQ routing. Some CardBus bridges have the capability of supporting both PCI and ISA style IRQ routing. The driver automatically determines the best choice for this option unless this keyword is used as an override.

LATENCY

specifies the latency timer for the CardBus Bridge. This parameter affects the bus mastering capabilities of the PRO/100 CardBus adapter. Changing this parameter may affect system performance. The range is a decimal number between 1 and 255. The default is 32. The default is 32. The latency should be lowered if more than one peripheral device, such as a modem, is being used. If the PRO/100 CardBus adapter is the only peripheral being used, use a higher latency, such as 255.

LINEMODE

For 16-bit DOS Drivers: LINEMODE selects either half-duplex or full-duplex mode for the network. Valid parameters are AUTO, HALF or FULL. Selecting full-duplex enables the PRO/100 CardBus adapter to send and receive data simultaneously when connected to a full-duplex hub. Default is AUTO.

For 32-bit NDIS3 Driver (M32A.SYS): LINEMODE selects either half-duplex or full-duplex mode for the network. Valid parameters are AutoDetect, Half Duplex, and Full-Duplex. Selecting full-duplex enables the PRO/100 CardBus adapter to send and receive data simultaneously when connected to a full-duplex switch. Default is keyword is AutoDetect.

LINESPEED

For 16-bit DOS Drivers: LINESPEED forces operation to 10 or 100 Mbps. If the keyword is not present the line speed will be automatically detected (default).

For 32-bit NDIS3 Driver (M32A.SYS):
 LINESPEED forces operation to 10 or 100 Mbps. Valid parameters are AutoDetect, 10 Mbps, and 100 Mbps. Default keyword is AutoDetect.

LINKDISABLE	disables link integrity for non-IEEE 10BASE-T networks such as StarLAN 10. Without this keyword in the driver command line, the driver defaults to link integrity ENABLED.
MEM	<i>see</i> MEMORY.
MEMORY	specifies the host PC memory location for the Intel adapter in hexadecimal notation, when MODE MEMORY (memory-mapped I/O) is being used (see MODE). The memory block occupies 4 Kbytes of host memory.
MODE	set this keyword to IO to disable requests for memory-mapped mode on systems that only support an I/O-driven card. The MEMORY setting provides increased performance on computers that allow simultaneous availability of memory and I/O resources.
NETWORKADDRESS	allows user to override adapter's unique network node address by specifying a different node address.
NOBURST	disables burst mode reads on the PRO/100 CardBus adapter. Using this keyword will force the adapter to initiate a bus-master request for each read, negatively impacting performance.
NOCHECK	disables verification of adapter resources. If the driver detection and verification code is causing problems when loading, this keyword can be used to turn the feature off.
NODEADDRESS	<i>see</i> NETWORKADDRESS.
NOEARLYRX	disables Advanced Look-ahead Pipelining features of the adapter. This keyword may be used to troubleshoot systems that have inexplicable network problems. Using this keyword may negatively impact performance.
NOEARLYTX	disables early transmit capability of the Adapter. This keyword may be used to troubleshoot systems that have inexplicable network problems. Using this keyword may negatively impact performance.

NOLED	turns off LED indicators on LAN adapter module to conserve power.
NOPREFETCH	disables prefetching in memory-mapped I/O mode by turning off this capability on the CardBus bridge. Using this keyword may negatively impact performance.
PCIIRQ	use this keyword to force the driver to use PCI IRQ routing. Some CardBus bridges have the capability of supporting both PCI and ISA style IRQ routing. The driver automatically determines the best choice for this option unless this keyword is used as an override.
PORT	(ODI) <i>see</i> IOADDRESS.
RXBUFFERSIZE	sets the size of the adapter receive packet buffer. This is a number in decimal in the range 1 - 30 for 16-bit drivers and 1 - 100 for the 32-bit ODI driver. Each packet adds approximately 1520 bytes to the resident size of the driver. The default is 15 packets.
S	(ODI)(MS-DOS command line only) displays LAN drivers resident in memory.
SINT	(Packet Driver) is a number from hexadecimal 60 to 80 designating a software interrupt. Default is 60.
SOCKET	For 16-bit DOS Drivers: identifies the number of the host computer's PC Card slot or socket into which the PRO/100 CardBus adapter is inserted. If a socket number is specified, only the specified socket is checked for the Intel adapter. If no socket is specified, all sockets are searched until the Intel adapter is found. For 32-bit NDIS3 Driver (M32A.SYS): identifies the number of the host computer's PC slot or socket into which the PRO/100 CardBus adapter is inserted. Valid parameters are AutoDetect, 1, 2, 3, and 4. If a socket number is specified, only the specified socket is checked for the Intel adapter. The default keyword is AutoDetect, and the driver will then automatically check all slots for the PRO/100 CardBus adapter.

TXBUFFERSIZE

sets the size of the adapter transmit packet buffer. This is the number of transmit packets in decimal in the range 1 - 10 for 16-bit drivers and 1 - 100 for the 32-bit ODI driver. Each packet adds approximately 1520 bytes to the resident size of the driver. The default is 2 packets.

U

(ODI)(MS-DOS command line only) unloads driver from memory.

Troubleshooting

This chapter contains troubleshooting information covering the most common issues encountered when installing the PRO/100 CardBus adapter, based on information developed by Intel Customer Support. This information is intended for users or network administrators who are already familiar with the PRO/100 CardBus adapter and its user documentation, and who have run into difficulties *after having completed the installation procedures* for the adapter, as described in the preceding chapters of this User's Guide.

This chapter contains the following headings:

- LED Indicators
- Diagnostic Test
- Error Messages
- General Troubleshooting
- Network Operating System Troubleshooting (Artisoft LANtastic, DEC PATHWORKS, Microsoft Windows 95, Microsoft Windows for Workgroups, Novell NetWare)
- Troubleshooting Checklist

Additional Sources of Information

In addition to this *User's Guide*, your computer and network documentation should also be consulted as needed. For the latest information on the PRO/100 CardBus adapter, see the **README** file on the Intel Network Drivers Disk, call the Intel BBS (see attached Support Page File), or visit the Intel World Wide Web site at <http://support.intel.com>. See **Appendix A** in this *User's Guide* for Intel support services access information.

LED Indicators

The LED indicators on the PRO/100 CardBus adapter TPE connector operate under the following conditions: (1) the card is inserted into a PC Card slot and (2) connected to the network, (3) computer is powered on, and (4) network driver has been loaded.

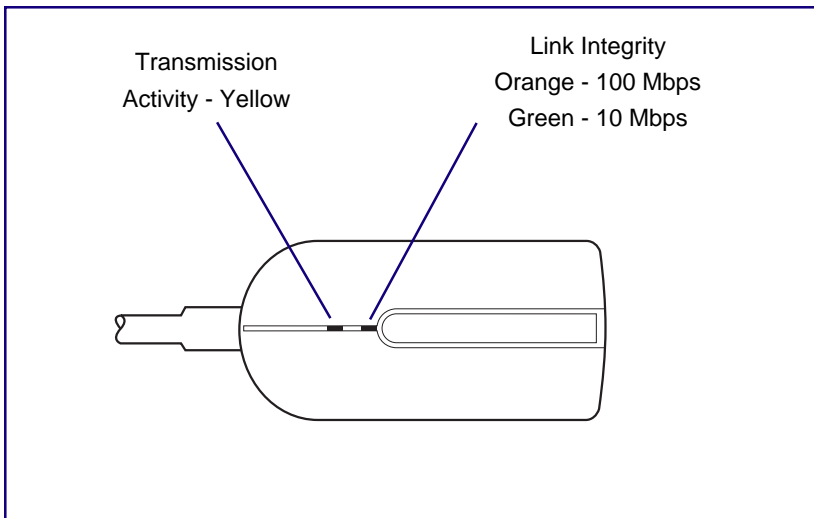

PRO/100 CardBus adapter TPE connector and LEDs

Diagnostic Self Test (MS-DOS only)

Intel provides a DOS-based self test diagnostics program. This program, located on the PRO/100 CardBus adapter Network Drivers Disk, tests several PRO/100 CardBus adapter functions. It also reports test results, the serial number of the unit, and the node address. M32ATEST can only be run from an MS-DOS command line.

This utility is intended to be a diagnostic tool in troubleshooting PRO/100 CardBus adapter configuration errors. It is designed to be simple to use and understand, yet provide valuable technical information. The program can run without a PRO/100 CardBus adapter, or even a CardBus machine, and still provide some functionality. The program is dynamic. This means cards can be inserted and removed at any time. Multiple cards can be tested and different configurations can be tested. M32ATEST.EXE can run in a DOS box in Windows, or Windows 95.

Executing the Self Test

Use the following steps to execute the self test.

- 1 Install the PRO/100 CardBus adapter according to the instructions contained in **Chapter 1, Hardware Installation** in this User's Guide.
- 2 Start your computer from DOS. DO NOT load a network driver.

NOTE:

Do not run M32ATEST with a network driver loaded. Loading a network driver before running M32ATEST may cause unpredictable results when exiting the test utility.

- 3 Run the diagnostic test by typing **M32ATEST at the MS-DOS prompt**, then press Enter. For example,
M32ATEST

NOTE:

If an error message displays when you execute the self test, see "Error Messages" later in this chapter.

Main Screen

The program consists of several function “buttons” and a view pane. Pressing or invoking a function will bring up the corresponding screen in the view pane. This view remains until another is selected. To exit M32ATEST type 'x' or push the 'Exit' button.

When a function is active, the button appears to remain down or pushed. Once the button pops up, the function is completed and the screen is a passive results display.

There are nine functions which can be invoked by pushing the associated button on the main screen. A button can be pushed by pressing the highlighted letter indicated on the button, or by using the left mouse button. Each function is explained below.

TEST

This function uses the current configuration to initialize the adapter and verify it is powered on and properly seated in its slot. It displays the current setting and test result for each parameter. Parameters are configured through the CONFIGURE function described below. If a card is detected and initialized successfully, the CIS information is displayed.

A failure may indicate that service is required for the PRO/100 CardBus adapter. Contact Intel Customer Support.

The CIS section displays the model and serial numbers of the unit, its manufacturing date and time, and its network node address. This data has been preprogrammed at the factory and cannot be altered.

Important

Write down the PRO/100 CardBus adapter model and serial numbers for reference

Customer Support will ask you to supply the model and serial numbers when requesting technical assistance or warranty service from Intel.

CONFIGURE

This function allows the user to set the parameters used for testing. The address mode can be set to Auto, Memory, or I/O. For Memory and I/O a hexadecimal address can be specified. The IRQ can be set to Auto, or IRQ. The IRQ selection can be used to force a particular interrupt, and a specific type of interrupt (PCI or ISA). The network line speed and line mode can also be set from this function.

SOFTWARE

This function attempts to determine what software is currently loaded which will affect the operation of the card. It displays the current version of DOS and Windows, and any Card and Socket Services available.

HARDWARE

This function attempts to determine if a CardBus Controller exists on the machine. It first checks for PCI BIOS extensions, and then it searches for any CardBus Controllers. If found it displays the vendor information and the PCI interrupt (if enabled by the BIOS)

NETWORK

This function enables the card on the Ethernet network and performs some diagnostics. It reports the operating mode and speed detected and monitors the network for traffic. Network traffic is shown on a graph. This graph provides a visual representation of the volume of traffic on the local area network (LAN). The Receive Statistics window displays the cumulative totals for received packets, KBytes, and Errors.

RESOURCES

This function attempts to determine free resources which can be utilized by the driver. It searches for memory, I/O, and IRQ.

ADVANCED

This function allows the user to setup advanced diagnostics.

ABOUT

This function displays the current version of the program.

HELP

This function displays the help screen.

EXIT

This function exits the application.

Error Messages

Except as noted, these messages are specific to the Intel PRO/100 CardBus adapter. They are listed in strict numerical/alphabetical order, i.e., numbers appear before letters and messages starting with “The” are under the letter T, initial “A” or “An” under the letter A.

For an explanation of other messages that may appear on the screen, see the network-specific or computer-specific troubleshooting later in this chapter, as well as your computer and network operating system documentation.

A card was not detected in the selected slot.

The SOCKET keyword was used to force a particular slot, but no PRO/100 CardBus adapter was detected there.

A CardBus interface could not be found.

The driver was unable to detect a CardBus bridge. Some machines require that the CardBus Bridge be enabled through the system BIOS. Check with the laptop manufacturer to find out how to enable the CardBus Bridge.

A PCI IRQ could not be set, and none exists for this slot

If the PCIIRQ keyword has been used to force PCI IRQ routing, but the IRQ keyword has not been set, this message may occur if the driver cannot set or verify an interrupt through the PCI BIOS. This keyword effectively disables the ISA IRQ routing capability of the driver.

A working IRQ could not be found

The resource detection could not find a usable IRQ. Either the system has no available IRQ resources, or the available IRQ resources could not be configured for the CardBus Bridge.

A PRO/100 CardBus adapter could not be found

The driver was able to detect a CardBus Bridge, but there was no Intel PRO/100 CardBus adapter inserted into a slot.

No free memory segment was found

The resource selection in the driver was unable to find a 4KByte block of memory available for the driver's use. Check to ensure that a 4KByte block of memory is excluded from any memory managers present. If the error persists, use the MEMORY keyword to force a known address that's available, and use the NOCHECK keyword to disable resource verification.

No network cable was detected. Line speed will be detected at run time

A network cable was not detected, or a cable fault occurred. The driver was unable to determine the speed of the network and will attempt to detect the correct speed as soon as a network link is established.

PCI BIOS is not present

The drivers require PCI BIOS to be installed in the system. Check with the laptop manufacturer to verify that it supports PCI BIOS calls.

PCI IRQ routing unavailable - the driver is using ISA IRQ routing

If the driver cannot set or verify an interrupt through the PCI BIOS, it will use ISA IRQ routing and display this message.

Please specify 0, 4, 8, 16, or 32 for the CACHE keyword

The CACHE keyword sets the cache line size on the CardBus bridge and the PRO/100 CardBus adapter. This parameter should not normally be modified.

Please specify a decimal number below 256 for the LATENCY keyword

The LATENCY keyword sets the latency timer on the CardBus bridge and the PRO/100 CardBus adapter. This parameter should not normally be modified.

Please specify a hexadecimal number for the MEMORY keyword

The value specified for the MEMORY keyword must be a hexadecimal number. For NDIS 3 use the form 0xD0000. All others use D0000.

Please specify a number between 3 and 15 for the IRQ keyword

The IRQ keyword only accepts decimal numbers between 3 and 15.

Please specify either HALF or FULL for the LINEMODE keyword

The LINEMODE keyword determines the duplex mode of the network. If the network connection is half-duplex, HALF should be used. If the network connection is full-duplex, FULL should be used. Do not set the duplex mode to full unless the network connection is configured this way. If the keyword is not present, the default is AUTO.

Please specify LOW, MEDIUM, or HIGH for the ERT keyword

The ERT keyword is used to set the Advanced-Lookahead threshold. This threshold determines how long to wait before notifying the host of a receive event. A lower threshold is better for slower machines, and a higher threshold for faster machines. Laptops with fast processors should use HIGH. This keyword is ignored if the NOEARLYRX keyword is present.

Please specify MEMORY or IO for the MODE keyword

The value specified for the MODE keyword must be MEMORY or IO.

The driver is out of memory - decrease the transmit or receive buffer size

The TXBUFFERSIZE and RXBUFFERSIZE keywords are used to configure the size of the buffers used by the adapter. These buffers reside in host memory. If the driver cannot allocate the amount of memory required by the specified configuration, it will display this error. Using the RXBUFFERSIZE and TXBUFFERSIZE keywords to reduce the size of the buffers can alleviate the problem.

The IRQ test failed

The IRQ keyword was used to force a value for the IRQ line, and the resource validation check failed. Either remove the IRQ keyword and let the driver automatically determine the IRQ, or disable resource checking by using the NOCHECK keyword.

The LINESPEED keyword must be set to 10 or 100

The LINESPEED keyword is used to force the network line speed to either 10 Mbps or 100 Mbps. If the keyword is not present the line speed is automatically detected.

The loopback test failed

Before the driver finishes loading, it runs a loopback test. This tests transmits a network packet internally testing all the transmit and receive hardware before going online. This test also checks that the resources the driver is using are valid. If the test fails it most likely means a hardware failure or an incompatibility between the card and the CardBus bridge. Adding keywords such as NOWRITEPOST, NOPREFETCH, and NOBURST may fix the problem.

The PCI IRQ could not be verified, the driver may not function

This message only occurs if the PCIIRQ keyword has been used to force PCI IRQ routing, and the IRQ keyword has been used to force a particular interrupt. If the driver cannot set or verify the IRQ through the PCI BIOS, it will give this message. If PCIIRQ is not present and the driver cannot set or verify the IRQ through the PCI BIOS it will use ISA IRQ routing.

The RXBUFFERSIZE keyword must be between 1 and 30

The value of the RXBUFFERSIZE keyword specifies the number of packets used in the receive buffer. Each packet requires approximately 1520 bytes of host memory.

The specified IRQ failed resource checking

The IRQ keyword was used to force a particular IRQ, but the resource checking in the driver reported a failure. To override the resource checking and load the driver anyway, use the NOCHECK keyword.

The selected memory is in use

The MEMORY keyword was used to force a particular memory address, but the resource checking in the driver reported a failure..

To override the resource checking and load the driver anyway, use the NOCHECK keyword.

The selected memory is a ROM address

The MEMORY keyword was used to force a particular memory address, but the resource checking in the driver reported a failure. To override the resource checking and load the driver anyway, use the NOCHECK keyword.

The selected memory is a RAM address

The MEMORY keyword was used to force a particular memory address, but the resource checking in the driver reported a failure. To override the resource checking and load the driver anyway, use the NOCHECK keyword.

The TXBUFFERSIZE keyword must be between 1 and 10

The value of the TXBUFFERSIZE keyword specifies the number of packets used in the transmit buffer. Each packet requires approximately 1520 bytes of host memory.

General Troubleshooting

If any of the following situations occurs after you have completed the installation procedure, review the accompanying information before calling Customer Support.

NOTE:

This section applies only if you are running MS-DOS, Microsoft Windows 3.x, or Workgroups 3.11 with Card and Socket Services that support CardBus. Upgrading to new drivers from Intel may also be required, as new Card and Socket software is released.

A driver failed to load, and I'm using Card and Socket Services

Card and Socket Services are a set of drivers designed to support the PC Card (PCMCIA) standard. These drivers are generally supplied by the computer manufacturer. Among other functions they

- Hide the PC Card socket hardware implementation from the PRO/100 CardBus adapter driver.
- Control the allocation of resources (memory windows, I/O ports, interrupts) to the PRO/100 CardBus adapter.

Recommendations for Use of Card and Socket Services with the PRO/100 CardBus adapter.

- A** If the memory manager EMM386.EXE is being used, verify that the memory required for the PRO/100 CardBus adapter has been excluded from use by the memory manager. Memory managers are generally loaded in the CONFIG.SYS. The memory exclusion required when using Card and Socket Services is generally larger than the exclusion needed by the PRO/100 CardBus adapter alone. The safest setting when troubleshooting is to “remark out” the entire “C” and “D” memory ranges, as follows:

```
DEVICE=C:[path]\EMM386.EXE NOEMS X=C000-DFFF
```

After the driver has been successfully loaded, the memory exclusion may be reduced through trial and error or in accordance with the Card and Socket Services documentation. The system must be rebooted before the revised settings take effect.

- B** When the PRO/100 CardBus adapter driver is loaded it either reads a configuration file or uses command line parameters to determine which resources it should use. The following is a list of driver types, driver file names, and the configuration method used by each:

Type	File Name	Configuration Method
ODI	M32AODI.COM	reads NET.CFG file
NDIS2	M32ANDIS.EXE	reads PROTOCOL.INI file
Packet	M32APD.EXE	uses COMMAND LINE parameters

The default resources used by the PRO/100 CardBus adapter for all drivers except the 32-bit ODI driver, in the absence of a contrary setting in the configuration file or on the command line are:

MEMORY	AUTO
IRQ	AUTO
IOADDRESS (NDIS)	AUTO
PORT (ODI)	AUTO

- C** Card and Socket Services will generally try to assign a set of resources (interrupt, memory window, I/O window) to the PRO/100 CardBus adapter. The resources configured for the PRO/100 CardBus adapter (in a configuration file or on a command line) must match the resources assigned by Card and Socket Services. If they do not, the driver will generally fail to load.

The way resources are assigned to the PC Card varies among Card and Socket Services manufacturers. The following section provides guidelines for SystemSoft Card and Socket Services. Review your Card and Socket Services documentation. To use Card and Socket Services with the PRO/100 CardBus adapter, you must know what resources will be assigned by Card and Socket Services, then specify the same resources when configuring the PRO/100 CardBus.

SystemSoft

The SystemSoft's CardSoft Card and Socket Services are loaded in the CONFIG.SYS file and generally include the following lines:

```
DEVICE=C:\CARDSOFT\SOCKET_SERVICES_DRIVER (This file varies by machine type)
```

```
DEVICE=C:\CARDSOFT\CS.EXE
```

```
DEVICE=C:\CARDSOFT\CSALLOC.EXE C:\CARDSOFT\CSALLOC.INI
```

```
DEVICE=C:\CARDSOFT\CARDID.EXE (Called a 'generic' card driver)
```

Resources assigned by CardSoft Card and Socket Services are controlled by the files CSALLOC.INI and CARDID.INI. CSALLOC.INI contains a list of resources available to Card and Socket Services. CARDID.INI controls how resources will be assigned to specific types of cards. The setting in the PRO/100 CardBus adapter driver configuration file should match the resources assigned by the LAN1xxxxxx keywords in the CARDID.INI file. The LAN1MEMORYBASE2 entry can be ignored.

A driver failed to load, and I'm NOT using Card and Socket Services

- A Verify that a block of memory for use by the PRO/100 CardBus adapter has been excluded from any memory manager being loaded. Memory managers are generally loaded in the CONFIG.SYS. The following example is given for EMM386.EXE and a PRO/100 CardBus adapter loading at its default memory address of D2000:

```
DEVICE=C:\PATH\EMM386.EXE NOEMS X=D200-D2FF
```

- B Since you are not using Card and Socket Services, verify that power management has been disabled and the PC Card socket is powered/enabled in the computer system's CMOS setup. These settings may not be present in all machines. Consult your computer documentation for information on how to access and modify the system setup.

- C** Reboot the machine by turning off the power and turning it back on again (cold boot). If the driver still fails to load, the cause is generally a resource conflict. Common causes of resource conflicts include sound systems, other PC Card adapters, and built in ROMs. The resources required for a PRO/100 CardBus adapter include a memory window (MEM keyword), an interrupt (INT keyword), and an I/O address (IOADDRESS keyword). The default settings are indicated below.

Review your computer documentation to determine what resources are available, or use a trial and error approach. The table on the next page shows a suggested trial and error sequence. If you use this method, be sure to add a memory exclusion from C000-DFFF to the EMM386.EXE line until a suitable memory location has been found. Then the memory exclusion can be reduced to a 4K window. Perform a cold boot between each trial to ensure that the PRO/100 CardBus adapter and PC Card sockets are completely reset.

When the PRO/100 CardBus adapter driver is loaded it either reads a configuration file or uses command line parameters to determine which resources it should use. See the list of driver types, driver file names, and configuration methods earlier in this chapter.

The default resources used by the PRO/100 CardBus adapter (except with the 32-bit ODI driver) when no other setting is stated are:

MEMORY	AUTO
IRQ	AUTO
IOADDRESS (NDIS)	AUTO
PORT (ODI)	AUTO

Troubleshooting combinations for driver configuration without Card and Socket Services:

TRIAL	MEM	INT	IOADDRESS
Default	D2000	5	320
1	CC000	5	320
2	D2000	10	320
3	CC000	10	320
4	D2000	11	320

5	CC000	11	320
6	D2000	15	320
7	CC000	15	320
8	D2000	5	340
9	CC000	5	340
10	D2000	10	340
11	CC000	10	340
12	D2000	11	340
13	CC000	11	340
14	D2000	15	340
15	D2000	15	340

The driver loaded successfully, but I can't get on the network

- A** Check all connections and verify that the cable drop is good (try a cable that is known to work on another workstation).
- B** Reboot by powering down the machine (cold boot). On some machines the PC Card controller chipset is not properly reset on a warm boot, and this can cause network errors.
- C** In a NetWare environment, verify that the frame type running on your network server is the same as the FRAME type listed first in the NET.CFG. If you are not sure what the correct Ethernet frame type is, check with your system administrator. On a multi-server network, add a preferred server statement to the NET.CFG.
- D** There could be an interrupt conflict. Try loading the driver with a different interrupt specified in the PRO/100 CardBus adapter configuration file. (This may also require some re-configuration of Card and Socket Services, if they're being used.)

- E If the problem persists, and you're on a 10BASE-T network, try patching directly into the hub. If the adapter works when plugged directly into the hub, but not when attached via a longer cable run, verify that the cable run length is within the IEEE 10BASE-T specification (100 meters). If the cable length is correct, the adapter may be defective. Contact Intel Customer Support.

Loopback failure reported when driver loads.

Add the MODE IO parameter to NET.CFG or MODE=IO to PROTOCOL.INI.

Download the latest driver from our website or BBS.

Windows won't load after installing adapter.

Try WIN /D:X. If windows loads this way, add the EMMExclude parameter in your SYSTEM.INI file under the [386ENH] section to exclude the memory range used by the Intel adapter.

For example:

EMMEXCLUDE=D000-D3FF

Network Operating System Troubleshooting

Artisoft LANtastic

Driver loads but I cannot attach to any other workstations on the network.

- Download the latest drivers from our website or BBS.
- Run the test utility to see if there is network traffic.
- Remove Card and Socket Services.

DEC PATHWORKS

This section only discusses the problems that might be related to configuration of the Intel adapter. For non-Intel related issues, consult your PATHWORKS user's manual. These are the PATHWORKS error codes (indicated by "percentage done"):

83 LOADING NDIS DRIVER...

```

86 LOADING NDIS DATA LINK...
89 PERFORMING NETBIND...
92 LOADING SCHEDULER...
93 LOADING DNP...
94 LOADING REDIRECTOR...
95 SETTING COMPUTER NAME...
98 NETWORK LOADING COMPLETED SUCCESSFULLY
    
```

Use /~# parameter when you run Pathworks SETUP. This will allow you to see any error messages given by any driver that fails to load.

- 1 If you hang on error code 83%, the Intel NDIS driver failed to load. Here are some possible reasons for the failure:
 - a Interrupt conflict - some machines use INT 5 for a sound card. Change the ni_irq to 10 or 11.
 - b Some machines require you to change the default memory setting. Try using CE00, C800, or D400. Make sure to make the corresponding changes:
 - in the mem parameter line in your PROTOCOL.INI,
 - in the memory exclusion of the EMM386.EXE line in your CONFIG.SYS.
 Sample PROTOCOL.INI change:

```
MEM=0XD400
```
 - c Some machines require using the mode=io parameter. Add mode=io to the Intel section in the PROTOCOL.INI file.
- 2 If you hang on error code 92%, the NDIS driver loaded properly but the scheduler failed to load. This is usually because your interrupt in the PROTOCOL.INI doesn't match the ni_irq line. Make sure you change the ni_irq line to match the INT you want to use. This process is described under DEC PATHWORKS in **Chapter 2, Software Installation.**

- 3 If everything loads and you don't connect to the network, try the following
 - a Choose another INT setting.
 - b Verify that you have a good cable.
 - c Verify that you have excluded the memory being used by the Intel adapter from the EMM386.EXE line of CONFIG.SYS.
 - d Make sure you have M32ANDIS.EXE version 1.14 or above.
 - e Always do a cold boot when troubleshooting.

Microsoft Windows 95 (including OSR2)

This troubleshooting information is intended primarily for users who already had Microsoft Windows installed on their system and are upgrading to Windows 95. It may also be helpful to new users of Windows 95 who were unable to successfully install the Intel driver using the instructions provided in **Chapter 2, Software Installation**.

Using Real Mode Card and Socket Services: When using Intel PC Card adapters, should I still use DOS real mode Socket Services Drivers?

No, it is recommended that you don't load the real mode Card and Socket Services drivers. It is also recommended that you boot the machine without EMM386.EXE in the CONFIG.SYS. In rare cases where you still want to load EMM386.EXE, make sure you don't use the highscan keyword with EMM386.EXE. Windows 95 does not detect devices correctly if there is a highscan keyword in the EMM386.EXE line of the CONFIG.SYS file.

Installing from SCSI CDROM or EXTERNAL CDROM: I am installing Windows 95 from a SCSI CD-ROM attached to a SCSI PC Card Adapter. How can I install Windows 95 if it is recommended that I don't load real mode card and socket services drivers since most SCSI requires me to load a real mode SCSI driver?

Put a copy of the directory for CAB files of Windows 95 from the CD-ROM on to your local hard drive. This will take up approximately 35MB of space. This will allow you to change settings on the system without using your CD-ROM. This also allows you to install Windows 95 without depending on the real mode SCSI CDROM driver.

Installing Windows 95 PC Card support: How do I install PC Card support for the PRO/100 CardBus adapter?

It is only necessary to install PC Card support in Windows 95 if the version of Windows 95 supports CardBus. Only Windows 95 version OSR2 or later supports CardBus. Consult the Windows 95 Installation section of this User's Guide for information on determining which version of Windows 95 you have.

NOTE:

If you do not have Windows 95 version 4.00.950b (OSR2) or later, the following instructions do not apply. The Intel PRO/100 CardBus adapter will be loaded using its own driver, and not by using Windows 95 PC Card support.

To install PC Card Socket support, it is always advisable to let Windows 95 do an autodetect to determine the type of PC Card controller you have. Also make sure you have not loaded any real mode Card and Socket Services drivers before proceeding.

- 1** Click the Start button in the lower left corner of the screen.
- 2** Choose the menu item: Settings.
- 3** Choose the menu item: Control Panel.
- 4** Double click on the "PC Card (PCMCIA)" icon.
- 5** One of two dialog boxes should appear:
 - a** If a dialog box entitled "PC Card (PCMCIA) Properties" appears, and "Socket Status" displays the status of Socket 1 and Socket 2, this means you have already installed the 32-bit PC Card support and you are finished. Proceed to Step 8.
 - b** If a dialog box entitled "Welcome to the PC Card (PCMCIA) Wizard" appears, proceed to step 6.
 - c** If neither of these dialog boxes appears, add PC Card support by doing the following: double click on My Computer, double click on Control Panel, double click on Add New Hardware, and click Yes for Autodetect. After Windows 95 detects and installs PC Card support, restart Windows 95, and go back to step 1.

- 6** The dialog box “Welcome to the PC Card (PCMCIA) Wizard” will ask the following question: “Are you using a PC card (networking card, CD-ROM connected to a SCSI card, etc.) to install windows?” The default answer is No. If you did use a PC Card SCSI adapter or a network card to install Windows 95, it is recommended that you keep a copy of the Windows 95 directory on your hard disk and not load any real mode PC Card or network drivers. Press Enter to select No.
- 7** The dialog box “PC Card (PCMCIA) Wizard” should now appear. It should read as follows: “Windows did not find any existing real mode PC Card drivers. Either you did not have any, or you have drivers that Windows couldn’t detect.” It will ask you “Do you want to review your system files and select real mode PC Card drivers so Windows can disable them?” The default answer should be No. Now use the following decision table:

 - a** If you are not sure if you have real mode Card and Socket Services or you do not know what they are, contact Microsoft Customer Support or the manufacturer of your notebook computer.
 - b** If you know that you do not have real mode Card and Socket Services installed, choose No and press Enter. Go on to step 8.
 - c** If you know that you have real mode Card and Socket Services and you wish to keep using them, this is not recommended. We recommend removing real mode drivers and using the 32-bit driver.
 - d** If you know that you have real mode Card and Socket Services installed and Windows 95 either did or did not detect them, you can now remove. Choose Yes and press Enter.
 - e** A new dialog box should appear and it should read: “Windows has selected the known PC Card drivers in your CONFIG.SYS file. Make sure that the correct drivers are selected, or make any changes. When you click Next, Windows will disable the selected PC card drivers in your CONFIG.SYS file.” Choose option 1, 2, or 3 below:

NOTE:

The dialog boxes displayed are the same except for the name of the file to be modified. The first box modifies the CONFIG.SYS, the next the AUTOEXEC.BAT and the third the SYSTEM.INI file.

- e1 Let Windows 95 automatically find the drivers for you. This is recommended. To do this click the Next button 3 times. This lets Windows 95 automatically modify the following files: CONFIG.SYS, AUTOEXEC.BAT, and SYSTEM.INI
 - e2 Choose the drivers yourself if none are selected. This is recommended only for experienced users.
 - e3 Override choices made by Windows 95. This is not recommended. Only experienced users should attempt this.
 - f This is the next to last dialog box for the wizard. It should read as follows: "You have finished the PC card wizard. To enable 32-bit support, click Finish, and then restart your computer for the changes to take effect." Click on the Finish button.
 - g A final box should appear entitled "System Settings Change". It should read as follows: "You must shut down Windows and TURN YOUR COMPUTER OFF to continue setting up this PC Card device. Would you like to shut down your computer now?" Click Yes. Make sure that the computer is completely turned off before turning it back on.
- 8 Insert your Intel CardBus adapter. Windows 95 should now detect the Intel card, and put up a dialog box. It should automatically load the drivers from the Windows 95 directory. If it asks you to supply a manufacturer's disk, insert the Intel Network Drivers Disk. Press Enter. It will ask you to restart now. Choose yes. (We recommend copying the Windows 95 RETAIL or WIN95 directory to your hard disk so that you won't be dependent on the CD-ROM every time you need to reinstall.)

Windows 95 version 4.00.950b (OSR2) - The CardBus Adapter is detected by Windows 95 OSR2 but does not initialize or continues to show errors in Device Manager after changing resources.

The PRO/100 CardBus adapter may need to be installed manually if Windows 95 OSR2 detects the PRO/100 CardBus adapter but does not initialize or continues to show errors in Device Manager after changing resources. (To determine whether you have Windows 95 OSR2, go to Settings, Control Panel, and System. The General tab in the System Properties window will list the version of Windows 95 installed on your system. The OSR2 version is 4.00.950b.)

Once the CardBus Adapter has been installed into a PC Card slot, Plug and Play and hot swapping in that PC Card slot are disabled. However, the other PC Card slot will continue to function normally, enabling Plug and Play and HotSwap of 16-bit and 32-bit PC Cards.

Manual Installation of the PRO/100 CardBus adapter under Windows 95 OSR2

- 1 Click the Start button in the lower left corner of the screen.
- 2 Choose the menu item: Settings.
- 3 Choose the menu item: Control Panel.
- 4 Double-click the System icon.
- 5 In the System Properties window, view the Device Manager tab.
- 6 In the Device Manager window, click PCMCIA socket.

There will be two CardBus controllers listed under PCMCIA socket.

- 6a If the PRO/100 CardBus adapter is in the top slot, click the top CardBus controller to select it.
 - 6b If the Adapter is in the bottom slot, click the bottom CardBus controller to select it (make a note of which slot the Adapter was in).
 - 6c Once the controller is selected, click Properties. Check the box Disable in this hardware profile. Click Ok. You will now see a red 'X' on the CardBus controller that was disabled. Click OK on the Device Manager tab.
- 7 Open a DOS session in Windows 95 OSR2 and delete the following files:

```
\WINDOWS\INF\*.BIN
```

```
\WINDOWS\INF\NETM32A.INF
```

```
\WINDOWS\SYSTEM\M32A.SYS
```

- 8 Rename the files CONFIG.SYS and AUTOEXEC.BAT to ensure that Windows 95 OSR2 runs in 32-bit protected-mode. Windows 95 OSR2 does not support the use of real-mode and protected-mode drivers simultaneously. This combination may cause unpredictable results. If these drivers are of mixed types, the computer might stall or the network might not work. The following commands can be used to rename the AUTOEXEC.BAT and CONFIG.SYS:

```
REN C:\AUTOEXEC.BAT C:\AUTOEXEC.00A
```

```
REN C:\CONFIG.SYS C:\CONFIG.00A
```
- 9 Shut down Windows 95 OSR2 and power off the machine. Remove the PRO/100 CardBus adapter physically from the PC Card slot (make a note of whether the Adapter was in the top or bottom PC

Card slot).

- 10 After Windows 95 OSR2 comes up and all drive activity has stopped, reinsert the Adapter in the same PC Card slot it was in previously. Click the Start button, select Settings, and then Control Panel. Double-click Add New Hardware. When asked, 'Do you want Windows to search for your new hardware?', select NO and click Next. Select '**Network adapters**' and click Next. Under Manufacturers select 'Intel' and click the Have Disk button. Insert the Intel Network Drivers diskette in the floppy drive and make sure A: is selected in the 'Copy Manufacturer's files from' box. Click OK. Select 'Intel' under Manufacturers and under Model select 'Intel EtherExpress PRO/100 CardBus adapter manual load', Click OK., then OK again, then Next and Finish.

You will now be welcomed to the PC Card (PCMCIA) Wizard. Typically, a copy of the Windows 95 OSR2 CAB files should be on the machine. When asked, 'Are you using a PC card to install Windows?', select 'No'. When asked 'Do you want to review your system files ..?', select No. Click Next and then Finish.

- 11 Select 'Yes' to shut down the computer so Windows 95 OSR2 will add the PRO/100 CardBus adapter in Device Manager and under Network components. Depending on the installation, you might be prompted for the Windows 95 OSR2 diskettes or CD to setup a basic Microsoft network. Windows 95 OSR2 includes 32-bit Clients for:
 - Microsoft Networks
 - NetWare Networks

Hardware Specific Issues: Are there Laptops or Notebooks that don't work with Windows 95 and PC Card adapters?

Read the HARDWARE.TXT file in the Windows 95 directory. This file is supplied by Microsoft and describes machine-specific problems.

NetWare Server is Not Found: Everything seems to load, I have checked that I have installed the Microsoft Client for NetWare, but I still can't see my NetWare server when I click on Network Neighborhood.

Sometimes the Frametype autodetection fails. You can force the frame type IPX uses by going to the My Computer, Control Panel, Network, IPX/SPX compatible properties.

Microsoft Windows for Workgroups

This section describes general troubleshooting procedures and possible error codes you might encounter under Windows for Workgroups. Before doing anything else, check your configuration files against the sample files in **Chapter 3, Configuration Reference** of this document.

Drivers load but you cannot see anybody on the network.

- Check that you have selected the correct workgroup.
- Ensure that there are no spaces in your computer name.

When trying to perform the add adapter function, an error occurs stating the OEMSETUP file does not contain adapter information.

Move or rename the oem*.inf files from the windows system directory (C:\WINDOWS\SYSTEM) and invoke the network setup program again.

Drivers do not load or errors are reported when NET START is executed.

Ensure you are excluding the memory range used by the Intel adapter from the memory manager in CONFIG.SYS.

Drivers do not load or errors are reported when NET START is executed for Windows For Workgroups.

Ensure you are excluding the memory range used by the Intel adapter from the memory manager in CONFIG.SYS.

If you are using NDIS2, edit the SYSTEM.INI file and look at NETCARD= line.

An error occurs when NET START executes for Windows For Workgroups.

Download the latest drivers from our website or BBS.

When using ODI for NetWare, I get attached to server, but can't see the F: login drive, "drive not ready" is the error message you get when trying to login.

There are several reasons that this will happen, but the most common reasons are:

- DoubleSpace defaults to G or H as lastdrive, thus H: or I: will be the login drive when using DoubleSpace. The lastdrive command in CONFIG.SYS seems to be overruled by DoubleSpace lastdrive.

Sample NET.CFG when using VLMs:

```
NetWare DOS Requester
FIRST NETWORK DRIVE = F
```

The following error occurred while loading protocol 0, error 58:...

This usually occurs when you have installed the IPX support stack in WFW and ODI, and later decided to switch to NDIS2 and not use IPX as another stack.

WFW sometimes will forget to remove the NWLINK.386 and NWBLINK.386 from the transport line in the [386enh] section of your C:\WINDOWS\SYSTEM.INI file. Fix this by making sure that the transport line in that section reads:

```
[386ENH]
```

```
TRANSPORT=NETBEUI.386
```

Error 7323 or 3658:, The IFSHLP.SYS driver is not installed, or Windows Network was not started, check your configuration.

Make sure the IFSHLP.SYS is installed in you CONFIG.SYS file and that this file exists in the C:\WINDOWS directory. See the sample CONFIG.SYS for proper syntax.

Error 7733: The protocol manager has reported an incomplete binding.

Make sure your \WINDOWS\PROTOCOL.INI has proper bindings. The MSSNDISHLP and NETBEUI sections should have a BINDINGS=M32AMAC. Chances are, the binding statement is wrong. See the sample PROTOCOL.INI file.

WFW works the first time I boot the machine, but after a warm boot, it fails to see other machines.

Turn off the power to shut down the machine and do a COLD BOOT. See if this fixes the problem.

When using WFW and ODI support for NetWare, I was able to login before I installed the WFW support for ODI. Now I can't see the server anymore.

You were probably using frame ethernet_802.2 for the IPXODI to connect to NetWare. The WFW network setup program shuffles the NET.CFG frame types such that ethernet_802.3 becomes the first. To solve this problem, just shuffle them back and make sure the first frame type is the one your IPXODI needs to use; in this case it is ethernet_802.2.

When I do the NetWare ODI stack, VLM says "No server found." Or, when I use NDIS2, everything loads but I can't see other machines on the network.

- 1 If using NetWare, try changing the first frame type in the C:\NWCLIENT\NET.CFG file. Make sure you know what frame type your NetWare server supports. IPX binds to the first frame type in the NET.CFG file.
- 2 Try without loading Card and Socket Services, and leave only the PRO/100 CardBus adapter in the machine with no other cards in there. This is always a good troubleshooting technique to create a bare-bones environment.
- 3 Change INT setting in the C:\NWCLIENT\NET.CFG file. Some machines use INT 5 for sound cards. Try changing the INT to 10 or 11 or 15.

If using ODI, use INT 11 in C:\NWCLIENT\NET.CFG.

If using NDIS2, use INT=11 in C:\WINDOWS\PROTOCOL.INI.

- 4 Check and make sure that the memory used by the PRO/100 CardBus adapter is excluded from the EMM386.EXE line in the CONFIG.SYS.

If it is already excluded, try changing memory to CC000. Make sure to make corresponding changes in the EMM386.EXE exclusion parameter in the CONFIG.SYS. For example:

x=cc00-cdff

- 5 Try swapping cards or cables whenever possible during troubleshooting.
- 6 Always do a COLD BOOT during troubleshooting.

Novell NetWare

Invalid network drive specified.

Check the LASTDRIVE parameter in CONFIG.SYS if using NETX, or the FIRST NETWORK DRIVE statement in NET.CFG if using VLM. These should be set to the letter after your last local drive. Typically one would use LASTDRIVE=E or FIRST NETWORK DRIVE=F. If you are using a hard drive compression program that creates extra drives (i.e. doublespace or stacker), you will need to increase the values of the parameters (i.e.: LASTDRIVE=H or FIRST NETWORK DRIVE=I).

File Server not found.

- Run the Intel test utility to see if any network traffic is visible.
- Check the frame types in the NET.CFG file. Your frame type must match the frame type used by the file server. Remember that the adapter binds to the first frame type listed in the NET.CFG. If you are not sure what frame types the Novell server is running, check the NET.CFG file of a workstation that is able to attach. If you have access to the server, type CONFIG at the server console and the screen will display the frame types.
- If this is a multi-server environment add a PREFERRED SERVER parameter to the NET.CFG file.
- Verify the network drop is working by using a cable drop that works for another workstation.

Troubleshooting Checklist

Try the following troubleshooting measures before calling Intel Customer Support:

- Read the README file on the floppy disk. It contains important information (including known incompatibilities and machine specific issues) that may solve your problem.
- Obtain current versions of drivers for your adapter from the Intel BBS or <http://support.intel.com>
- Boot the computer in a clean environment (press F8 or hold down the Shift key to bypass loading of CONFIG.SYS and AUTOEXEC.BAT), then use the Intel test utility to see if the adapter is functioning and detecting network traffic.
- When loading drivers or running the test utility, have the dongle cable attached to the PRO/100 CardBus adapter.
- Under Novell, ensure that the FRAME TYPE you are using is the same as that of the file server. The server frame type should be specified as the first frame type in the NET.CFG.
- In a twisted pair environment, try plugging directly into the hub or concentrator.
- Try using a network connection that works for another computer.
- Try using the Intel adapter on a different computer.
- Try another Intel adapter if available.
- If your computer has multiple PC Card sockets, move the adapter to another socket.
- If you have more than one PC Card device in your computer, remove the non-Intel PC Card devices during your configuration/testing.
- Make sure you are using the most recent version of Card and Socket Services. Call the computer manufacturer or the company that makes the Card and Socket Services. **Upgrading to new drivers from Intel may also be required, as new Card and Socket Services software is released.**
- Check with your laptop PC manufacturer for BIOS updates. Your BIOS may need upgrading.
- Test the Intel adapter without loading Card and Socket Services to see if there is a conflict between the Intel adapter configuration and that of Card and Socket Services. The interrupt, memory address location, and I/O address specified to the Card and Socket service drivers must match the Intel configurations in NET.CFG or PROTOCOL.INI (if used).

- Make sure that the Intel adapter is not conflicting (interrupt, memory address, I/O address) with any other adapters or hardware that is installed in the computer (including sounds cards, CD-ROM drives and PEN devices).
- Try loading the CardBus drivers at different memory locations (i.e.: C800, CC00, D400, D800).
- Try using different interrupt locations (i.e.: 5, 10, 11). Check BIOS settings for PCI interrupts.
- Try using different port addresses (i.e.: 280, 290, 310, 320).
- Try adding the parameter `MODE=IO` in `PROTOCOL.INI` or `MODE IO` in `NET.CFG`.
- If the Intel adapter was functioning correctly then stopped, make sure none of configuration files have been changed by newly installed software or hardware.
- Disable all power management features in the CMOS settings on the computer.
- Disable all shadow RAM features in the CMOS settings on the computer.
- Ensure that you are excluding the memory range used by the Intel adapter from your memory manager (`EMM386.EXE`, `QEMM.EXE`, etc.).

Intel Automated Customer Support

You can reach Intel's automated support services 24 hours a day, every day at no charge. The services contain the most up-to-date information about Intel products. You can access installation instructions, troubleshooting information, and general product information.

	World Wide Web & Internet FTP	Intel Bulletin Board Service (BBS)
	Access Intel's World Wide Web home pages or download information using anonymous FTP.	Use Intel's BBS. Dial in by modem at 8-N-1, and up to 14.4 Kbps.
Troubleshooting	✓	
Software updates	✓	✓
Installation notes	✓	
Product information	✓	
How to access:	See web addresses on next page.	US and Canada: 1-503-264-7999 Europe: +44-1793-432955 Worldwide: +1-503-264-7999

Intel Web and Internet Sites

Support: <http://support.intel.com>

News: <news://cs.intel.com>

Network Products: <http://www.intel.com/network>

Corporate: <http://www.intel.com>

FTP Host: <ftp.intel.com>

FTP Directory: /pub/support/enduser_reseller/etherexpress_lan_adapters

Intel Customer Support Technicians

Other support services: You can purchase a range of support services, including 24 hour support, per incident support, on-site service, and software and hardware maintenance agreements. For details about the Intel Support Service options, download document 8549 from one of the automated services.

Worldwide access: Intel has technical support centers worldwide. Many of the centers are staffed by technicians who speak the local languages. For a list of all Intel support centers, the telephone numbers, and the times they are open, download document 9089 from one of the automated services.

If you don't have access to automated services, contact your local dealer or distributor. Or call +1-916-377-7000 from 07:00 to 17:00 Monday - Friday, U.S. Pacific Time.

Specifications

General Specifications

Model MBLA3200

Cable: 100Base-TX unshielded twisted pair for use on Category 5 (data grade) cabling; 10Base-T unshielded twisted pair (UTP)

Connector: RJ-45

Operating Distance: 328 ft (100 m)

Ethernet specifications

Ethernet IEEE 802.3 for 10 Mbps, 802.3u for 100 Mbps

Type II CardBus PC Card

Full or half duplex at 10 or 100 Mbps

Size: 3.37 in (86 mm) x 2.13 in (54.0 mm)
x 0.20 in (5.0 mm) excluding adapter cable
and network connection

Weight: 0.85 oz (24 g)

Power Requirements:

10Base-T 3.3V DC, 360 mA typical, 440 mA max

100Base-TX 3.3V DC, 285 mA typical, 315 mA max

General Specifications (continued)

Temperature Range:

Operating:	32°F to 131°F (0°C to 55°C)
Storage:	-4°F to 149°F (-20°C to 65°C)
Humidity:	95% max. noncondensing
LEDs:	Link integrity, transmission activity
Certification:	FCC Code of Federal Regulations, Title 47, Part 15, Subpart B, Class A CE Mark (EN55022, Class A, EN50082-1)

Compatibility

Platforms

At the time of printing this manual, the PRO/100 CardBus 32 adapter supports popular CardBus compliant PCs, including Acer, Fujitsu, Dell, Compaq, DEC, Hewlett-Packard, IBM, NEC, Texas Instruments, and Toshiba. Contact Intel for an updated list of CardBus compliant PCs.

Card and Socket Services

Supports CardBus compliant PC Card support in Windows 95 version 4.00.950b (OSR2) and later. Contact Intel for an updated list of Card and Socket Services supporting CardBus and information on using the PRO/100 CardBus 32 adapter with that software.

Network Operating Systems

Supports all popular network operating systems including Novell NetWare, Microsoft Windows 95, Microsoft Windows NT, Microsoft Windows for Workgroups, Microsoft LAN Manager, Artisoft LANtastic, Banyan VINES, and DEC PATHWORKS. NDIS and ODI support for DOS and IBM OS/2. Packet driver support for TCP/IP.

Technical Specifications

- Supports Toshiba ToPIC 95, Texas Instruments PCI 1130 and PCI 1131, Cirrus Logic CL-PD 6832 and Ricoh.
- Variable interrupts, 3 to 15.
- Variable I/O window, 128 bytes needed.
- Requires only a 4Kbyte memory window on a 4Kbyte boundary, within segment C000h to EF00h (DOS drivers only).
- Keyword disables link integrity checking.
- Suspend/resume and HotSwap support in Windows 95 OSR2 and later.
- Full-duplex capability on 10 or 100 Mbps full-duplex network (requires full-duplex switch).
- Advanced Look-Ahead Pipelining increases performance.
- Windows-based installation program automatically configures PC and NOS setup.
- Diagnostic test program (M32ATEST.EXE)

Supported Environments

- NDIS 3 driver for Microsoft Windows 95 and Microsoft Windows NT 3.51 and 4.0.
- Packet Driver
- Novell NetWare 16-bit ODI client for DOS, Windows for Workgroups, and OS/2 and 32-bit ODI for DOS, Windows 3.x, and Windows 95 (including OSR2).
- NetWare Server for versions 3.12, 4.10, and 4.11.
- NDIS2 DOS, Windows for Workgroups 3.11 and IBM OS/2.

Limited Lifetime Warranty

Intel warrants to the original owner that the hardware product delivered in this package will be free from defects in material and workmanship. This warranty does not cover the product if it is damaged in the process of being installed or improperly used.

THE ABOVE WARRANTY IS IN LIEU OF ANY OTHER WARRANTY, WHETHER EXPRESS, IMPLIED OR STATUTORY, INCLUDING BUT NOT LIMITED TO ANY WARRANTY OF MERCHANTABILITY, FITNESS FOR A PARTICULAR PURPOSE ARISING OUT OF ANY PROPOSAL, SPECIFICATION, OR SAMPLE.

This warranty does not cover replacement of adapter products damaged by abuse, accident, misuse, neglect, alteration, repair, disaster, improper installation, or improper testing. If the product is found to be otherwise defective, Intel, at its option, will replace or repair the product at no charge except as set forth below, or refund your purchase price provided that you deliver the product along with a Return Material Authorization (RMA) number (see below), along with proof of purchase (if not registered), either to the dealer from whom you purchased it or to Intel with an explanation of any deficiency. If you ship the product, you must assume the risk of damage or loss in transit. You must use the original container (or the equivalent) and pay the shipping charge. Intel may replace or repair the adapter product with either new or reconditioned parts, and any part or product replaced becomes Intel's property. Repaired or replaced products will be returned at the same revision level as received or higher, at Intel's option. Intel reserves the right to replace discontinued product with an equivalent current generation product.

This warranty gives you specific legal rights and you may have other rights which vary from state to state. All parts or components contained in this hardware product are covered by Intel's limited warranty for this product; the product may contain fully tested, recycled parts, warranted as if new. For warranty information call one of the numbers below.

Returning a defective product

From North America:

Before returning any product, contact Intel Customer Support and obtain a Return Material Authorization (RMA) number by calling +1-916-377-7000.

If the Customer Support Group verifies that the product is defective, they will have the RMA department issue you an RMA number to place on the outer package of the product. Intel cannot accept any product without an RMA number on the package.

All other locations:

Return the product to the place of purchase for a refund or replacement.

INTEL ADAPTER MONEY-BACK GUARANTEE (North America Only)

Intel wants you to be completely satisfied with the Intel adapter product that you have purchased. Any time within ninety (90) days of purchase, you may return your **Intel adapter** to the original place of purchase for a full refund of the purchase price from your dealer. Resellers and Distributors, respectively, accepting returns and refunding money back to their customers may return Intel adapters to their original place of purchase. Intel guarantees that it will accept returns under this policy and refund the original purchase price to customers purchasing directly from Intel.

Limitation of Liability and Remedies

INTEL SHALL HAVE NO LIABILITY FOR ANY INDIRECT, SPECULATIVE, CONSEQUENTIAL, INCIDENTAL, PUNITIVE OR SPECIAL DAMAGES ARISING FROM THE USE OF OR INABILITY TO USE THIS PRODUCT INCLUDING, WITHOUT LIMITATION, LOSS OF USE, BUSINESS INTERRUPTIONS, LOSS OF PROFITS, AND LOSS OF GOODWILL, WHETHER ANY SUCH DAMAGES ARISE OUT OF CONTRACT NEGLIGENCE, TORT, OR UNDER ANY WARRANTY, IRRESPECTIVE OF WHETHER INTEL HAS ADVANCE NOTICE OF THE POSSIBILITY OF ANY SUCH DAMAGES. NOTWITHSTANDING THE FOREGOING, INTEL'S TOTAL LIABILITY FOR ALL CLAIMS UNDER THIS AGREEMENT SHALL NOT EXCEED THE PRICE PAID FOR THE PRODUCT. THESE LIMITATIONS ON POTENTIAL LIABILITIES WERE AN ESSENTIAL ELEMENT IN SETTING THE PRODUCT PRICE. INTEL NEITHER ASSUMES NOR AUTHORIZES ANYONE TO ASSUME FOR IT ANY OTHER LIABILITIES.

Limited Lifetime Hardware Warranty

Some states do not allow the exclusion or limitation of incidental or consequential damages, so the above limitations may not apply to you.

Software provided with the hardware product is not covered under the hardware warranty described above. See the applicable software license agreement which shipped with the adapter product for details on any software warranty.

April 28, 1994

Network Software License Agreement

BY USING THIS SOFTWARE, YOU ARE AGREEING TO BE BOUND BY THE TERMS OF THIS AGREEMENT. DO NOT USE THIS SOFTWARE UNTIL YOU HAVE CAREFULLY READ AND AGREED TO THE FOLLOWING TERMS AND CONDITIONS. IF YOU DO NOT AGREE TO THE TERMS OF THIS AGREEMENT, PROMPTLY RETURN THE SOFTWARE PACKAGE AND ANY ACCOMPANYING ITEMS.

LICENSE: Intel Corporation (“Intel”) grants you the non-exclusive right to use the enclosed software program (the “Software”). You will not use, copy, modify, rent, sell or transfer the Software or any portion thereof except as provided in this Agreement.

You may:

1. Install/use the Software on a single computer or on a single local area network (“LAN”) server;
2. Copy the Software solely for backup or archival purposes, including copying the Software into memory.

RESTRICTIONS:

You **Will Not**:

1. Sublicense the Software;
2. Reverse engineer, decompile, or disassemble the Software;
3. Copy the Software, in whole or in part, except as provided in this Agreement.

TRANSFER: You may transfer the Software to another party if the receiving party agrees to the terms of this Agreement and you retain no copies of the Software and accompanying documentation. Transfer of the Software terminates your right to use the Software.

OWNERSHIP AND COPYRIGHT OF SOFTWARE: Title to the Software and all copies thereof remain with Intel or its vendors. The Software is copyrighted and is protected by United States and international copyright laws. You will not remove the copyright notice from the Software. You agree to prevent any unauthorized copying of the Software.

DUAL MEDIA SOFTWARE: If the Software package contains multiple media, you may only use the disks appropriate for your single-user computer or LAN.

WARRANTY: The Software is provided “AS IS.” Intel warrants that the media on which the Software is furnished will be free from defects in material and workmanship for a period of one (1) year from the date of purchase. Upon return of such defective media, Intel’s entire liability and your exclusive remedy shall be the replacement of the Software.

THE ABOVE WARRANTIES ARE THE ONLY WARRANTIES OF ANY KIND EITHER EXPRESS OR IMPLIED INCLUDING WARRANTIES OF MERCHANTABILITY OR FITNESS FOR ANY PARTICULAR PURPOSE.

LIMITATION OF LIABILITY: NEITHER INTEL NOR ITS VENDORS SHALL BE LIABLE FOR ANY LOSS OF PROFITS, LOSS OF USE, LOSS OF DATA, INTERRUPTIONS OF BUSINESS, NOR FOR INDIRECT, SPECIAL, INCIDENTAL OR CONSEQUENTIAL DAMAGES OF ANY KIND WHETHER UNDER THIS AGREEMENT OR OTHERWISE, EVEN IF ADVISED OF THE POSSIBILITY OF SUCH DAMAGES.

AUDIT: Intel reserves the right to have audits conducted to verify your compliance with this Agreement.

TERMINATION OF THIS LICENSE: Intel may terminate this license at any time if you are in breach of any of its terms and conditions. Upon termination, you will immediately destroy the Software or return all copies of the Software and documentation to Intel.

U.S. GOVERNMENT RESTRICTED RIGHTS: The Software and documentation were developed at private expense and are provided with “RESTRICTED RIGHTS.” Use, duplication, or disclosure by the Government is subject to restrictions as set forth in FAR 52.227-14 and DFAR 252.227-7013 et seq. or its successor.

EXPORT LAWS: You agree that the distribution and export/re-export of the Software is in compliance with the laws, regulations, orders or other restrictions of the U.S. Export Administration Regulations.

APPLICABLE LAW: This Agreement is governed by the laws of the State of California and the United States, including patent and copyright laws. Any claim arising out of this Agreement will be brought in Santa Clara County, California.

Regulatory Agency Notices

FCC Compliance Statement

This product has been tested and found to comply with the limits for a Class B computing device pursuant to Part 15 of the FCC rules. These limits are designed to provide reasonable protection against harmful interference in a residential installation. Installed correctly, it probably will not interfere with radio or TV reception. However, we do not guarantee the absence of interference.

This product generates and uses energy of about the same frequency as radio and TV broadcasts. Installed incorrectly, it may interfere with reception of radio and TV broadcasts.

If you suspect this product is causing interference, turn your computer on and off while the radio or TV is showing interference. If the interference disappears when you turn the computer off and reappears when you turn the computer on, something in the computer is causing interference.

To reduce interference, try these suggestions:

- Change the direction of the radio or TV antenna.
- Move the computer, radio or TV. For example, if the computer is to the right of the TV, move it to the left of the TV. Or move them farther apart.
- Plug the computer into a different electrical outlet than the radio or TV.
- Ensure that all expansion slots (on the back or side of the computer) are covered. Also ensure that all metal retaining brackets are tightly attached to the computer.

NOTE

This device complies with Part 15 of the FCC Rules. Operation is subject to the following two conditions: (1) This device may not cause harmful interference, and (2) this device must accept any interference received, including interference that may cause undesired operation.

CAUTION

If the device is changed or modified without permission from Intel, the user may void his or her authority to operate the equipment.

Canadian compliance (Industry Canada)

When tested in at least one intended host:

This digital apparatus does not exceed the Class B limits for radio noise emissions from digital apparatus set out in the interference-causing equipment standard entitled “Digital Apparatus”, ICES-003 of the Canadian Department of Communications.

Cet appareil numérique respecte les limites bruits radioélectriques applicables aux appareils numériques de Class B prescrites dans la norme sur le matériel brouilleur: “Appareils Numériques”, NMB-003 édictée par le Ministre Canadien des Communications.

Manufacturer declaration

This certifies that Intel EtherExpress PRO/100 Mobile Adapters comply with the EU Directive 89/336/EEC, using the EMC standards EN55022 (Class B) and EN50082-1. This product also meets or exceeds EN60950 safety requirements.

This product has been tested and verified to meet CISPR 22 Class B requirements.

Intel Corporation
Network Products Division - MS JF3-408
2111 N.E. 25th Ave.
Hillsboro, Oregon 97124

Index

Symbols

100Base-TX 1
10Base-T 1
15-pin connector 1, 4

A

Artisoft LANtastic 26
 installation 26
 sample configuration files 60
 troubleshooting 104
AT&T StarGROUP
 installation 26
Autodetection of PC Cards 2

B

Banyan VINES
 installation 26
 sample configuration files 63
Bulletin Board 119

C

Cabling
 data grade 1
Card and Socket Services 56, 99, 101
 SystemSoft 101
Category 5 cabling 1, 2
Configuration
 files, sample 60
Customer Support 119

D

DCOMPVLM.BAT 41, 47, 53
DEC PATHWORKS 28
 installation 28
 sample configuration files 64

- troubleshooting 104
- Default values 25
- Device driver 25
- Diagnostic Test Utility
 - parameters 82
- Diagnostics 91
- Driver parameters 71

E

- Equipment, required 2
- Error messages 94
- Exclusion, memory 60

F

- FTP LANWatch
 - installation 31
 - NDIS driver 32
 - Packet driver 31
- FTP PC/TCP 33
 - and NetWare 36
 - installation 33
 - Packet driver 35
- Full-duplex operation 59

G

- Generic installation 37

H

- HotSwap 58
- HP LAN Manager
 - installation 37

I

- IBM DOS LAN Requestor 40
- IBM Local Area Network Support Program 38
 - installation 38, 39
- IBM Local Area Support Program 38
- IBM PC LAN 40
- Installation
 - generic 37

- manual 41
- Microsoft Windows 21
- Microsoft Windows for Workgroups 21
- Novell NetWare 21
- Program, Xircom 21, 25, 44, 55
- VLM shell 21

Installation, manual

- Windows 95 OSR2 110

Intel Web and Internet Sites 120

L

LAN Manager

- Ungermann-Bass Net/One 51

LANtastic, Artisoft 26

LANWatch, FTP 31

LED indicators 90

Loopback failure 104

M

Manual installation 41

Memory

- exclusion 60

Messages 94

N

NDIS 3.0 driver

- parameters 76

NDIS driver

- Artisoft LANtastic 26
- FTP LANWatch 31
- FTP PC/TCP 33
- generic 37
- Microsoft Windows for Workgroups 43
- parameters 73
- SunSoft PC-NFS 48
- Ungermann-Bass Net/One LAN Manager 51
- Wollongong PathWay Access for DOS 52

NET.CFG file 72, 73

Network

- drivers 25
- Drivers Disk 25

- operating system 21, 25
- software installation 25
- NETX shell support 21
- Novell NetWare 47
 - and FTP PC/TCP 36
 - installation 21
 - troubleshooting 115

O

- ODI driver
 - FTP PC/TCP 33
 - generic 37
 - Microsoft Windows for Workgroups 43
 - parameters 71
 - Wollongong PathWay Access for DOS 52
- OnNet with FTP PC/TCP 33, 34
- OSR2 109, 110

P

- Packet driver
 - FTP LANWatch 31
 - FTP PC/TCP 33
 - loading sequence 82
 - parameters 81
- Parameters, driver 71
- PATHWORKS, DEC 28
- PC Card slots 2
- PC-NFS 48
- PC/TCP, FTP 33
- Pipelining, Advanced Look-ahead 59
- Power during installation 2
- Power management 58
- Product registration card 1
- Protective adapter case 1
- PROTOCOL.INI file 74

R

- Removal, PC Card 4
- Required equipment 2
- RJ-45 connector 2, 5

S

- Sample files, configuration 60
 - Artisoft LANtastic 60
 - Banyan VINES 63
 - DEC PATHWORKS 64
 - Windows for Workgroups 65
- Self test 91
- slots, PC Card 2
- Software updates 119
- SunSoft PC-NFS
 - installation 48
- Suspend/resume 58
- SystemSoft Card and Socket Services 101

T

- Troubleshooting 89, 98
 - Artisoft LANtastic 104
 - checklist 116
 - DEC PATHWORKS 104
 - Microsoft Windows 95 106
 - Microsoft Windows for Workgroups 112
 - Novell NetWare 115

U

- Ungermann-Bass Net/One
 - installation 51

V

- VINES, Banyan 26
- VLM file decompression 41
- VLM shell 21

W

- Windows 95 8
 - Toshiba 13
 - Version 4.00.95b (OSR2) 15
- Windows for Workgroups 21, 43

INDEX

- ODI driver 44
 - removing old installation 46
 - with NetWare 44
- Windows NT 18
- Wollongong PathWay Access
 - installation 52
- Wollongong PathWay Access for DOS 52
 - NDIS driver 52
 - ODI driver 53
- World Wide Web 119

Free Manuals Download Website

<http://myh66.com>

<http://usermanuals.us>

<http://www.somanuals.com>

<http://www.4manuals.cc>

<http://www.manual-lib.com>

<http://www.404manual.com>

<http://www.luxmanual.com>

<http://aubethermostatmanual.com>

Golf course search by state

<http://golfingnear.com>

Email search by domain

<http://emailbydomain.com>

Auto manuals search

<http://auto.somanuals.com>

TV manuals search

<http://tv.somanuals.com>