



# Intel<sup>®</sup> 82801EB (ICH5) I/O 82801ER (ICH5R), and 82801DB (ICH4) Controller Hub: AC '97 PRM

Programmers Reference Manual (PRM)

---

*April 2003*

Document Number: **252751-001**



INFORMATION IN THIS DOCUMENT IS PROVIDED IN CONNECTION WITH INTEL® PRODUCTS. NO LICENSE, EXPRESS OR IMPLIED, BY ESTOPPEL OR OTHERWISE, TO ANY INTELLECTUAL PROPERTY RIGHTS IS GRANTED BY THIS DOCUMENT. EXCEPT AS PROVIDED IN INTEL'S TERMS AND CONDITIONS OF SALE FOR SUCH PRODUCTS, INTEL ASSUMES NO LIABILITY WHATSOEVER, AND INTEL DISCLAIMS ANY EXPRESS OR IMPLIED WARRANTY, RELATING TO SALE AND/OR USE OF INTEL PRODUCTS INCLUDING LIABILITY OR WARRANTIES RELATING TO FITNESS FOR A PARTICULAR PURPOSE, MERCHANTABILITY, OR INFRINGEMENT OF ANY PATENT, COPYRIGHT OR OTHER INTELLECTUAL PROPERTY RIGHT. Intel products are not intended for use in medical, life saving, or life sustaining applications.

Intel may make changes to specifications and product descriptions at any time, without notice.

Designers must not rely on the absence or characteristics of any features or instructions marked "reserved" or "undefined." Intel reserves these for future definition and shall have no responsibility whatsoever for conflicts or incompatibilities arising from future changes to them.

The Intel® 82801EB (ICH5) I/O 82801ER (ICH5R), and 82801DB (ICH4) controller hub may contain design defects or errors known as errata which may cause the product to deviate from published specifications. Current characterized errata are available on request.

Contact your local Intel sales office or your distributor to obtain the latest specifications and before placing your product order.

I<sup>2</sup>C is a two-wire communications bus/protocol developed by Philips. SMBus is a subset of the I<sup>2</sup>C bus/protocol and was developed by Intel. Implementations of the I<sup>2</sup>C bus/protocol may require licenses from various entities, including Philips Electronics N.V. and North American Philips Corporation.

Intel and the Intel logo are trademarks or registered trademarks of Intel Corporation or its subsidiaries in the United States and other countries.

\*Other names and brands may be claimed as the property of others.

Copyright © 2003, Intel Corporation



# Contents

---

1	Introduction.....	7
1.1	About This Document.....	7
1.2	Reference Documents and Information Sources .....	9
2	Overview .....	11
2.1	Intel® ICH5 AC '97 Controller Compatibility .....	11
2.1.1	Third AC '97 Component Specification Revision 2.1, Revision 2.2 and Revision 2.3 Compliant Codecs.....	14
2.1.2	Dedicated S/P DIF DMA Output Channel .....	15
2.1.3	20 Bits Surround PCM Output.....	15
2.1.4	Memory Map Status and Control Registers .....	15
2.1.5	Second Independent Input DMA Engines.....	16
2.1.6	PCI Local Bus Specification, Revision 2.3 Power Management.....	16
2.2	General Requirements .....	16
3	Intel® ICH5 AC '97 Controller Theory of Operation .....	17
3.1	Intel® ICH5 AC '97 Initialization.....	17
3.1.1	System Reset.....	17
3.1.2	Codec Topology.....	17
3.1.3	BIOS PCI Configuration .....	18
3.1.4	Hardware Interrupt Routing.....	19
3.1.5	PCI Lock .....	19
3.2	DMA Engines.....	20
3.2.1	Buffer Descriptor List .....	20
3.2.2	DMA Initialization.....	21
3.2.3	DMA Steady State Operation.....	23
3.2.4	Stopping Transfers.....	24
3.2.5	FIFO Error Conditions.....	24
3.2.5.1	FIFO Underrun .....	24
3.2.5.2	FIFO Overrun .....	24
3.3	Channel Arbitration.....	25
3.4	Data Buffers.....	25
3.4.1	Memory Organization of Data .....	25
3.4.2	PCM Buffer Restrictions.....	25
3.4.3	FIFO Organization.....	26
3.5	Multiple Codec/Driver Support.....	27
3.5.1	Codec Register Shadowing.....	28
3.5.2	Codec Access Synchronization.....	29
3.5.3	Data Request Synchronization in Audio Split Configurations.....	29
3.6	Power Management .....	30
3.6.1	Codec Topologies .....	30
3.6.1.1	Tertiary Codec Topologies.....	31
3.6.2	Power Management Transition Maps .....	31
3.6.3	Power Management Topology Considerations .....	34

	3.6.3.1	Determining the Presence of Secondary and Tertiary Codecs.....	34
	3.6.3.2	Determining the Presence of a Modem Function .....	35
	3.6.4	Resume Context Recovery .....	35
	3.6.5	Aggressive Power Management .....	35
	3.6.5.1	Primary Audio Requested to D3 .....	36
	3.6.5.2	Secondary Modem Requested to D3.....	36
	3.6.5.3	Secondary Modem Requested to D0.....	36
	3.6.5.4	Audio Primary Requested to D0 .....	37
	3.6.5.5	Using a Cold or Warm Reset.....	37
4		Surround Audio Support.....	39
	4.1	Determine Codec's Audio Channels.....	39
	4.2	Enabling Intel® ICH5 AC '97 Controller Audio Channels .....	40
5		20-Bits PCM Support.....	43
6		Independent S-P/DIF Output Capability .....	45
7		Support for Double Rate Audio .....	47
8		Independent Input Channels Capability.....	49
	8.1	Link Topology Determination .....	49
9		Intel® ICH5 AC '97 Modem Driver .....	51
	9.1	Robust Host-Based Generation of a Synchronous Data Stream .....	51
	9.1.1	Spurious Data Algorithm .....	52
	9.1.2	Intel® ICH5 AC '97 Spurious Data Implementation .....	52



## Figures

Figure 1. Block Diagram of Platform Chipset with Intel® ICH5 Component .....	13
Figure 2. Intel® ICH5 AC '97 Controller Connection to Its Companion Codecs .....	14
Figure 3. Generic Form of Buffer Descriptor (One Entry in the List) .....	20
Figure 4. Buffer Descriptor List .....	21
Figure 5. Compatible Implementation with Left and Right Sample Pair in Slot 3/4 Every Frame.....	26
Figure 6. Compatible Implementation with Sample Rate Conversion Slots 3 and 4 Alternating over Next Frame .....	26
Figure 7. Incompatible Implementation of Sample Rate Conversion with Repeating Slots over Next Frames .....	27

## Tables

Table 1. Applicable Components .....	7
Table 2. Audio Features Distribution Matrix .....	12
Table 3. Audio Registers .....	18
Table 4. Modem Registers .....	19
Table 5. BD Buffer Pointer (DWORD 0: 00-03h) .....	20
Table 6. BD Control and Length (DWORD 1: 04-07h).....	21
Table 7. Audio Descriptor List Base Address.....	22
Table 8. Modem Descriptor List Base Address.....	22
Table 9. Audio Last Valid Index.....	22
Table 10. Modem Last Valid Index.....	23
Table 11. FIFO Summary.....	27
Table 12. SDM Register Description .....	28
Table 13. Dual Codecs Topologies .....	30
Table 14. Power State Mapping for Audio Single or Dual (Split) Codec Desktop Transition .....	32
Table 15. Power State Mapping for Modem Single Codec Desktop Transition .....	32
Table 16. Power State Mapping for Audio in Dual Codec Desktop Transition .....	33
Table 17. Power State Mapping for Modem in Dual Codec Desktop Transition .....	34
Table 18. Extended Audio ID Register.....	39
Table 19. Single Codec Audio Channel Distribution .....	39
Table 20. Multiple Codec Audio Channel Distribution .....	40
Table 21. CM 4/6 –PCM Channels Capability Bits .....	40
Table 22. AC-Link PCM 4/6 -Channels Enable Bits .....	41
Table 23. Sample Capabilities.....	43
Table 24. PCM Out Mode Selector .....	43
Table 25. Global Control Register S-P/DIF Slot Map Bits .....	45
Table 26. Topology Descriptor .....	49
Table 27. SDATA_IN Map.....	49
Table 28. Codec Ready Bits.....	50
Table 29. MMBAR: Mixer Base Address Register .....	50

## Revision History

---

Revision Number	Description	Revision Date
-001	Initial Release.	April 2003

# 1 Introduction

## 1.1 About This Document

This document was prepared to assist Independent Hardware and Software Vendors (IHVs and ISVs) in supporting the Intel® I/O controller hub (ICH5) AC '97 controller feature set. This document also applies to the previous generation of Intel I/O controller hub components and describes the general requirements to develop an audio driver that will make use of the AC '97 audio interface.

This document also describes functions that the BIOS or Operating Systems (OS) must perform in order to ensure correct and reliable operation of the platform. This document will be supplemented from time to time with specification updates. The specification updates contain information relating to the latest programming changes. Check with your Intel representative for availability of specification updates.

The following table outlines ICH device information at a glance.

**Table 1. Applicable Components**

Device Name	Vendor ID	Device ID	Subsystem Vendor ID	Subsystem Device ID	Base Class Code	Sub-Class Code	Prog. Interface	Revision ID	Bus Number (PCI Addr)	Device Number	Function Number	Microsoft PNP Device Node ID	Intel Desired Device Description (INF name) Name for: Microsoft Windows* Operating System
Intel® ICH	8086	2415	Default is 00h. Value of this register varies according to the system	Default is 00h. Value of this register varies according to the system	04h	01h	00h	ALL	00h	1Fh	5	PCI\VEN_8086&DEV_2415 (subsystem will also provide additional information)	Intel® 82801AA AC '97 Audio Controller (displayed by driver provider's INF)
Intel ICH	8086	2416	Default is 00h. Value of this register varies according to the system	Default is 00h. Value of this register varies according to the system	07h	03h	00h	ALL	00h	1Fh	6	PCI\VEN_8086&DEV_2416 (subsystem will also provide additional information)	Intel 82801AA AC '97 Modem Controller (displayed by driver provider's INF)
Intel ICH-0	8086	2425	Default is 00h. Value of this register varies according to the system	Default is 00h. Value of this register varies according to the system	04h	01h	00h	ALL	00h	1Fh	5	PCI\VEN_8086&DEV_2425 (subsystem will also provide additional information)	Intel® 82801AB AC '97 Audio Controller (displayed by driver provider's INF)

Device Name	Vendor ID	Device ID	Subsystem Vendor ID	Subsystem Device ID	Base Class Code	Sub-Class Code	Prog. Interface	Revision ID	Bus Number (PCI Addr)	Device Number	Function Number	Microsoft PNP Device Node ID	Intel Desired Device Description (INF name) Name for: Microsoft Windows* Operating System
Intel® ICH-0	8086	2426	Default is 00h. Value of this register varies according to the system	Default is 00h. Value of this register varies according to the system	07h	03h	00h	ALL	00h	1Fh	6	PCI\VEN_8086&DEV_2426 (subsystem will also provide additional information)	Intel 82801AB AC '97 Modem Controller (displayed by driver provider's INF)
Intel® ICH2	8086	2435	Default is 00h. Value of this register varies according to the system	Default is 00h. Value of this register varies according to the system	04h	01h	00h	ALL	00h	1Fh	5	PCI\VEN_8086&DEV_2435 (subsystem will also provide additional information)	Intel® "ICH2" AC '97 Audio Controller (displayed by driver provider's INF)
ICH2	8086	2436	Default is 00h. Value of this register varies according to the system	Default is 00h. Value of this register varies according to the system	04h	01h	00h	ALL	00h	1Fh	6	PCI\VEN_8086&DEV_2436 (subsystem will also provide additional information)	Intel® ICH2 DT/Server /Mobile/Low End" AC '97 Modem Controller (displayed by driver provider's INF)
Intel® ICH3	8086	2445	Default is 00h. Value of this register varies according to the system	Default is 00h. Value of this register varies according to the system	04h	01h	00h	ALL	00h	1Fh	5	PCI\VEN_8086&DEV_2445 (subsystem will also provide additional information)	Intel® "ICH3" AC '97 Audio Controller (displayed by driver provider's INF)
ICH3	8086	2446	Default is 00h. Value of this register varies according to the system	Default is 00h. Value of this register varies according to the system	04h	01h	00h	ALL	00h	1Fh	6	PCI\VEN_8086&DEV_2446 (subsystem will also provide additional information)	Intel® ICH3 DT/Server /Mobile/Low End" AC '97 Modem Controller (displayed by driver provider's INF)
Intel® ICH4	8086	24C5	Default is 00h. Value of this register varies according to the system	Default is 00h. Value of this register varies according to the system	04h	01h	00h	ALL	00h	1Fh	5	PCI\VEN_8086&DEV_24C5 (subsystem will also provide additional information)	Intel® "ICH4" AC '97 Audio Controller (displayed by driver provider's INF)
ICH4	8086	24C6	Default is 00h. Value of this register varies according to the system	Default is 00h. Value of this register varies according to the system	04h	01h	00h	ALL	00h	1Fh	6	PCI\VEN_8086&DEV_24C6 (subsystem will also provide additional information)	Intel® ICH4 DT/Server /Mobile/Low End" AC '97 Modem Controller (displayed by driver provider's INF)





Device Name	Vendor ID	Device ID	Subsystem Vendor ID	Subsystem Device ID	Base Class Code	Sub-Class Code	Prog. Interface	Revision ID	Bus Number (PCI Addr)	Device Number	Function Number	Microsoft PNP Device Node ID	Intel Desired Device Description (INF name) Name for: Microsoft Windows* Operating System
Intel® ICH5	8086	24D5	Default is 00h. Value of this register varies according to the system	Default is 00h. Value of this register varies according to the system	04h	01h	00h	ALL	00h	1Fh	5	PCI\VEN_8086&DEV_24D5  (subsystem will also provide additional information)	Intel® "ICH5" AC '97 Audio Controller (displayed by driver provider's INF)
ICH5	8086	24D6	Default is 00h. Value of this register varies according to the system	Default is 00h. Value of this register varies according to the system	04h	01h	00h	ALL	00h	1Fh	6	PCI\VEN_8086&DEV_24D6  (subsystem will also provide additional information)	Intel® ICH5 DT/Server / Low End" AC '97 Modem Controller (displayed by driver provider's INF)

## 1.2 Reference Documents and Information Sources

Document Name or Information Source	Available From
Audio Codec '97 Specification, Revision 2.1, Revision 2.2 and Revision 2.3	<a href="http://www.intel.com/labs/media/audio/index.htm">http://www.intel.com/labs/media/audio/index.htm</a>
Communications and Networking Riser Specification, Version 1.0 and 1.2	<a href="http://developer.intel.com/technology/cnr/">http://developer.intel.com/technology/cnr/</a>
PCI Local Bus Specification, Revision 2.3	<a href="http://www.pcisig.com/specifications/conventional/">http://www.pcisig.com/specifications/conventional/</a>
Microsoft Windows* Driver Development Kits – <a href="http://www.microsoft.com/ddk">http://www.microsoft.com/ddk</a>	Microsoft
Microsoft Windows* Driver and Hardware Development – <a href="http://www.microsoft.com/hwdev">http://www.microsoft.com/hwdev</a>	Microsoft

### NOTE:

- Contact your Intel representative for the current document revision.



This page is intentionally left blank.

## 2 Overview

---

In this document, “ICH5” stands for I/O Controller Hub 5. The ICH5 provides an AC '97-compliant controller. References to the “AC '97 Component Specification” refer to the *Audio Codec '97 Specification*, Revision 2.1, Revision 2.2, and Revision 2.3. The ICH5 AC '97 Digital Controller implementation interfaces to AC '97 Component Specification, Revision 2.3 and below-compliant codecs. The ICH5 supports up to three AC '97 Component Specification compliant codecs on the AC-link interface.

This document is limited to specifying the software requirements and driver interface for the ICH5 AC '97 digital controller. Wherever possible, it has pointers to additional considerations for supporting future proliferation or derivatives of the ICH5 digital controller. However, considerations for these future devices are subject to change.

### 2.1 Intel® ICH5 AC '97 Controller Compatibility

The ICH5 AC '97 controller is fully compatible with the features found in the ICH1/2/3/4 versions. This allows for current drivers developed by ISVs and IHVs to work without modifications. The ICH5 however, provides capabilities not found in ICH family components prior to ICH4. The following matrix provides a description of the available features for each of the ICHx component generations. This document specifically addresses features on ICH5 while maintaining the original programming model reference for new developers working directly with ICH5 and not previously exposed to the ICH component.

Figure 1 displays a block diagram of the platform chipset with the ICH5 component. Figure 2 represents the typical configuration for the ICH5 AC '97 controller and companion codecs.

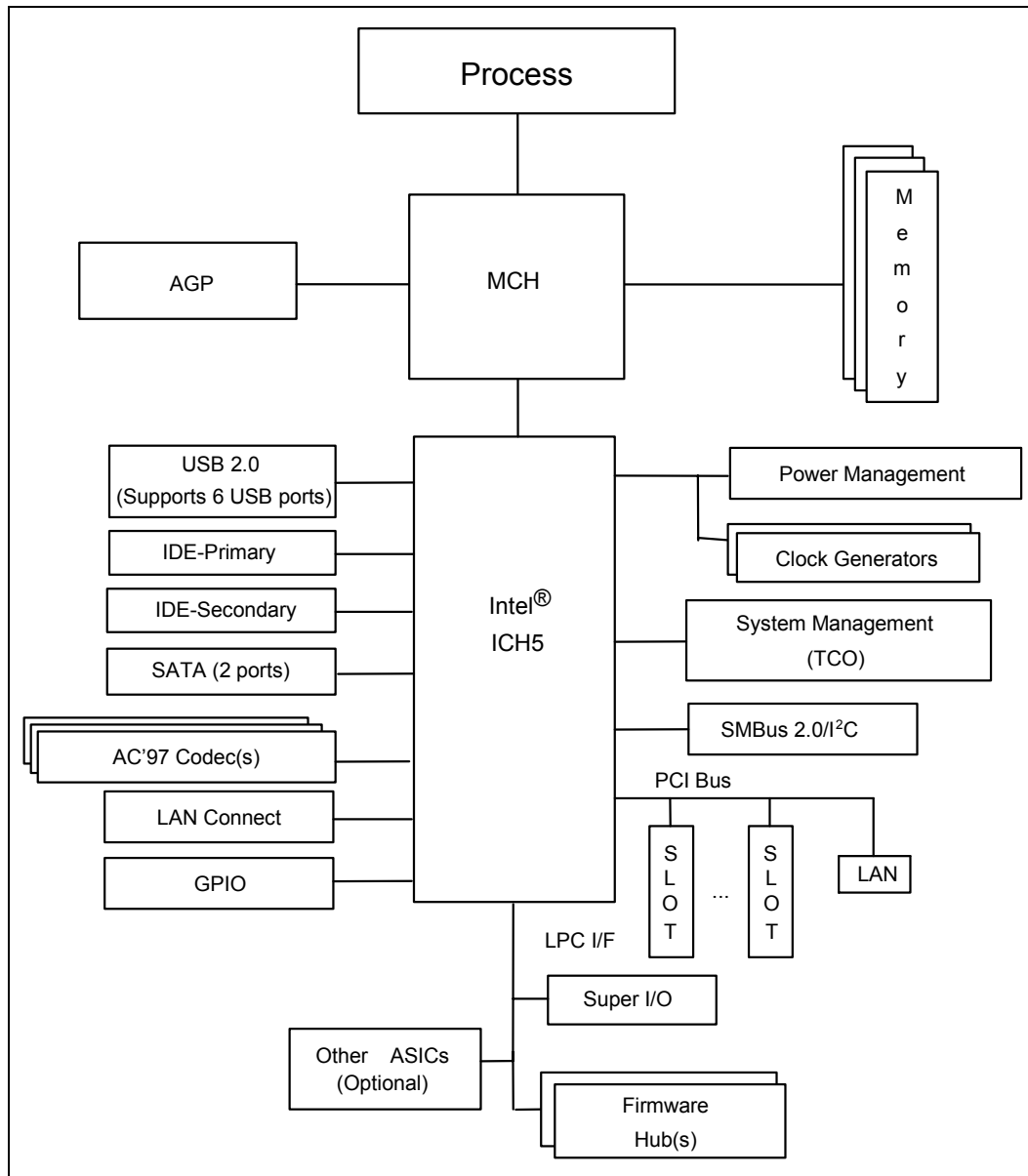

**Table 2. Audio Features Distribution Matrix**

AC '97 Audio Controller Features	Intel® ICH	Intel® ICH2	Intel® ICH3	Intel® ICH4	Intel® ICH5
16 bits Stereo PCM Output	☒	☒	☒	☒	☒
16 bits Stereo PCM Input	☒	☒	☒	☒	☒
16 bits Microphone Input	☒	☒	☒	☒	☒
GPIO and Interrupt Support	☒	☒	☒	☒	☒
Two 2.1/2.2/2.3 Codec Support	☒	☒	☒	☒	☒
16 bits 2/4/6 Ch. Surround PCM Output		☒	☒	☒	☒
20 bits 2/4/6 Ch. Surround PCM Output				☒	☒
Dedicated S/P DIF DMA Output Ch.				☒	☒
Third 2.1/2.2/ 2.3 Codec Support				☒	☒
Memory Map Control and Status				☒	☒
Second 16 bits Stereo PCM Input				☒	☒
Second 16 bits Microphone Input				☒	☒
PCI 2.3 Power Management				☒	☒

The ICH5 AC '97 audio controller provides a set of features that require significant software support. The following paragraphs provide a summary of these features.

The modem support infrastructure has not been changed in any generation of the I/O controller hub starting with the ICH.

Figure 1. Block Diagram of Platform Chipset with Intel® ICH5 Component



**Figure 2. Intel® ICH5 AC '97 Controller Connection to Its Companion Codecs**

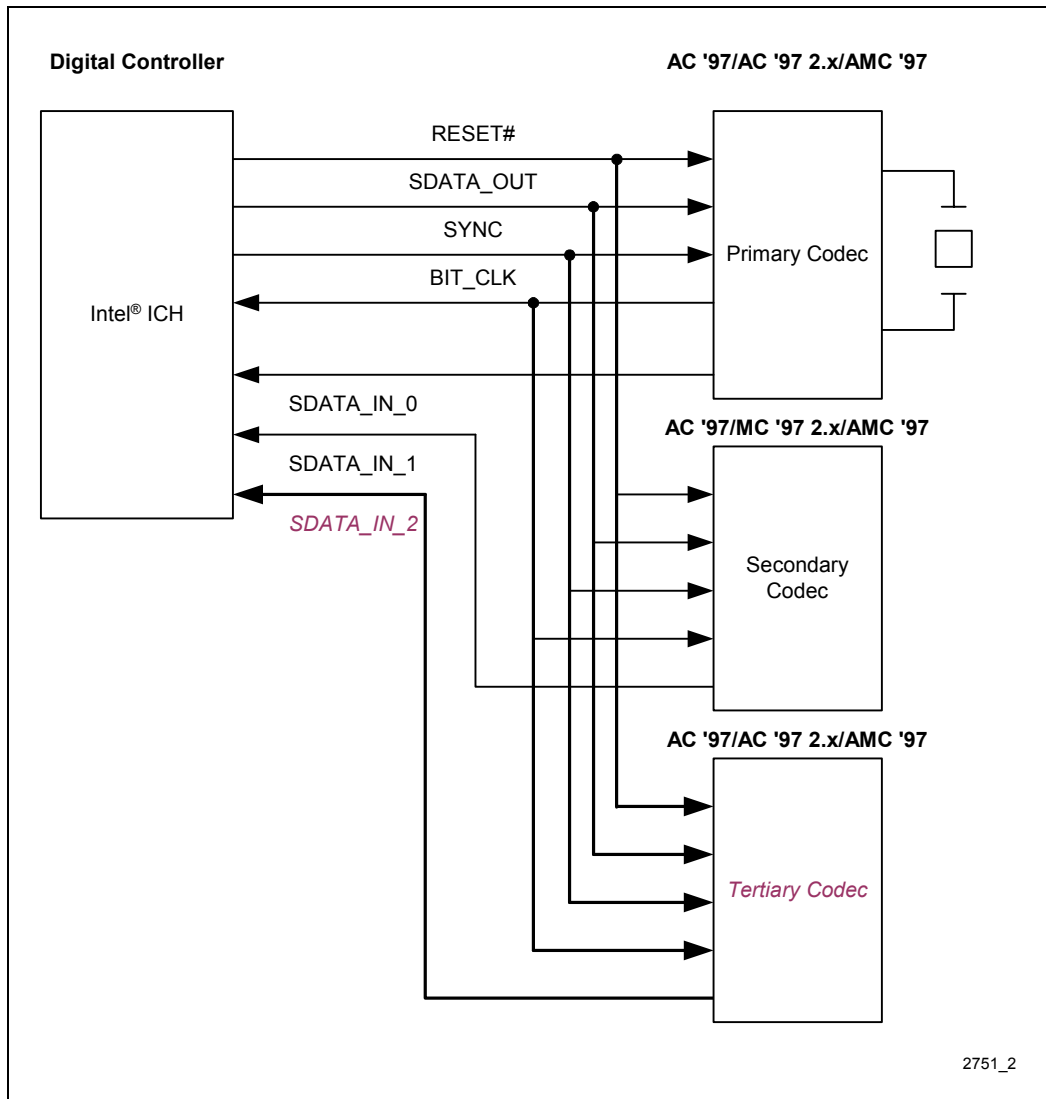

### 2.1.1 Third AC '97 Component Specification Revision 2.1, Revision 2.2 and Revision 2.3 Compliant Codecs

The *AC '97 Component Specification* provides capability for up to four, SDATA\_IN signals in support of up to four codecs. The ICH5 AC '97 controller provides support for up to three codecs to allow for Audio channel expansion without sacrificing the Modem Codec (MC) support. Also, the third codec capability enables a better mobile docking infrastructure.

## 2.1.2 Dedicated S/P DIF DMA Output Channel

The ICH5 controller provides a dedicated DMA engine with the capability of outputting either PCM or AC-3 data to the S/P DIF link for pass-through to an external CE audio decoder. This capability allows for simultaneous output of PCM/AC-3 on the S/P DIF link while PCM data is output to the PCM Out DMA engine. As a result, an AC3 stream from DVD movie playback can be output on the S/P DIF link concurrently with other system audio data (e.g., voice audio from a telephony application).

## 2.1.3 20 Bits Surround PCM Output

The AC '97 Component Specification provides a maximum bit resolution of 20 bits per sample. The ICH5 AC '97 controller PCM Output DMA Engine fully exploits this capability to improve the audio output quality.

## 2.1.4 Memory Map Status and Control Registers

The ICH5 support PCI Memory Base Address Register that allows for higher performance access to the controller registers while expanding the register space to access the third codec support mechanism. All features can now be accessed via this Memory BAR making the I/O BAR capabilities obsolete. However, the ICH5 controller may maintain the I/O BAR capability to allow for the reuse of legacy code maintaining backward compatibility to deployed driver binaries.

**Note:** This document describes the programming interface using the Memory BAR registers unless otherwise indicated. The default configuration for ICH5 Audio function is to use the PCI Memory Base Address Register. The I/O BAR is therefore disabled unless system BIOS enables the simultaneous backward-compatible capability on the register:

Device 31 Function 5 Audio			
Offset	Register	Default	Comments
41h	CFG Configuration	00h	When cleared, the I/O space BARs at offset 10h and 14h become read only registers. This is the default state for the I/O BARs. Initialized by BIOS when backward I/O Bar compatibility is required Memory BARs are always enabled.

## 2.1.5 Second Independent Input DMA Engines

The ICH5 continues to provide two sets of input DMA engines that allow for the secondary or tertiary codecs to provide recording PCM data streams on the primary codec while simultaneously providing recording capabilities from the secondary or tertiary codec. A typical application is to provide independent input stream in a mobile docking configuration where an audio codec is located in the base system (notebook unit) and the secondary or tertiary codec is located in a docking unit for desktop replacement. The DMA engines provide the infrastructure for s/w to select the input stream from either source for stereo or microphone recording. Also the capability of simultaneous input streams opens the possibilities for more futuristic applications where a multiple microphone array can be created using two codecs. Refer to Section 3.2 for more information on how to program the DMA engines.

## 2.1.6 PCI Local Bus Specification, Revision 2.3 Power Management

The ICH5 provides *PCI Local Bus Specification, Revision 2.3*-compliant power management registers that allows for better OS power management support with reduced overhead to the BIOS programmers using ACPI control methodologies.

## 2.2 General Requirements

It is assumed that the reader has a working knowledge of AC '97 architecture and the ICH5 AC'97 controller implementation. Also, the reader should have an understanding of audio driver development for the target operating systems.

This document outlines the software specification for the AC '97 digital controller, and also includes details necessary for development of an audio device driver.



## 3 Intel® ICH5 AC '97 Controller Theory of Operation

---

The ICH5 AC '97 digital controller (DC) interface is an implementation of the AC-link, with additional features to support the transaction and device power management. The ICH5 AC'97 DC includes DMA engines for high-performance data transfer to memory via a hub interface.

ICH5 AC'97 DC and AC-link support isochronous traffic, which emphasizes the timing of the data. This is critical to maintain the data stream from the audio and/or modem codec.

### 3.1 Intel® ICH5 AC '97 Initialization

#### 3.1.1 System Reset

The ICH5 AC '97 circuitry is reset on power up by combining the PCIRST# signal with the AC Link RESET# signal. However, AC Link RESET# will not follow PCIRST# during a resume from sleep condition. During operation, the system can be reset by clearing the AC '97 cold reset bit in the Global Control/Status register (GLOB\_CNT). This bit is maintained during ICH5 sleep mode and can be used by the driver to select warm or cold reset during a resume condition. At least one codec must be present. Otherwise, ICH5 AC '97 is not supported and the codec ready will never be seen by the controller. Once the reset has occurred, a **read** to Mixer register 00h/80h will indicate what type of hardware resides in the codec(s).

Software must ensure that the codec ready bit is present for the appropriate Global Control/Status register (GLOB\_CNT). Before writing any value on the codec registers or initiating a DMA transfer, s/w must ensure that the codec has reached a ready status by reading the Audio codec register Powerdown Control/Status register (Index 26h) or Extended Modem Status and Control register (Index 3Eh) correspondingly.

#### 3.1.2 Codec Topology

The following rules present the allowable codec configuration when attaching to the AC-link interface. To avoid improper driver loading, the system BIOS should determine the presence of the audio or modem codec attached on the AC-link, and enable the Audio or Modem function's PCI configuration space accordingly.

**The following are the loading rules for ICH5:**

1. Maximum of three codecs total on the link
2. Maximum of a single modem function, either as Modem Codec or a combination Audio/Modem Codec

This information is used to disable (hide) the appropriate PCI function. To determine that a codec or codecs are attached to the link, the System BIOS follows an algorithmic approach.

Drivers can distribute output and input data in appropriate slots associated with available codec(s). For example a 6-channel data stream can be separated into three, 2-channel codec streams as long as the codecs are programmed to decode the appropriate slot output stream (SDATA\_OUT). Similarly ICH5 provides two stereo PCM input channels as well as two microphone mono input DMA channels. These allow for separate input streams for stereo PCM and microphone recording from two different codecs simultaneously.

Software should match sample rates, when two codecs are teamed together. The codecs must have matching vendors, types, and be explicitly supported in software. Essentially, audio codecs must be programmed with a common sample rate. The selection of a common sample rate is based on each codec's capabilities, as detailed in Section 3.5.3.

### 3.1.3 BIOS PCI Configuration

The ICH5 AC '97 controller, as previously indicated, exposes two PCI functions in the ICH5 (Bus 0, Device 31h). This allows for driver differentiation between these capabilities in the component.

- Function 5: ICH5 AC '97 audio controller
- Function 6: ICH5 AC '97 modem controller

As PCI devices there are a number of registers that are required to be initialized to enable these functions. The following table summarizes these requirements.

**Table 3. Audio Registers**

Device 31 Function 5 Audio			
Offset	Register	Default	Comments
04h-05h	Command (COM)	0000h	Bit 2: Bus Master Enable Bit 1: Memory Space Enable Bit 0: When enable in 41h I/O Space Enable
10h-13h	Native Audio Mixer Base Address (NAMBAR)	00000001h	<u>When enable in 41h</u> Address in the 64-K I/O space that allows 256 bytes of registers not in conflict with any other set
14h - 17h	Native Audio Bus Mastering Base Address (NABMBAR)	00000001h	<u>When enable in 41h</u> Address in the 64-K I/O space that allows 256 bytes of registers not in conflict with any other set
18h – 1Bh	Memory Audio Mixer Base Address (MMBAR)	00000000h	Address in the 4-GB memory space that allows 512 bytes of registers not in conflict with any other set
1Ch – 1Fh	Memory Bus Master Base Address Register (MBBAR)	00000000h	Address in the 4-GB memory space that allows 512 bytes of registers not in conflict with any other set
3Ch	Interrupt Line (INTLN)	00h	A hardware interrupt (0-Fh) that follows value assigned to PIRQB#. Has not effect on ICH5 it is used to indicate software the IRQ value assigned to the device.
41h	CFG Configuration	00h	When cleared, the I/O space BARs at offset 10h and 14h become read only registers. This is the default state for the I/O BARs. Initialize by BIOS when backward I/O Bar compatibility is required Memory BARs are always enabled.

**Table 4. Modem Registers**

Device 31 Function 6 Modem			
Offset	Register	Default	Comments
04h-05h	Command (COM)	0000h	Bit 2: Bus Master Enable Bit 0: I/O Space Enable
10h-13h	Native Audio Mixer Base Address	00000001h	Address in the 64-K I/O space that allows 256 bytes of registers not in conflict with any other set
14h - 17h	Native Audio Bus Mastering Base Address (MBAR)	00000001h	Address in the 64-K I/O space that allows 256 bytes of registers not in conflict with any other set
3Ch	Interrupt Line (INTLN)	00h	A hardware interrupt (0-Fh) that follows value assigned to PIRQB#. Has not effect on ICH5 it is used to indicate software the IRQ value assigned to the device.

With the exception of register 41h on Device 31 Function 5, initialization of the PCI registers above is the responsibility of the PnP capable OS. If a PnP OS is not available in the system, it is then the BIOS's responsibility to configure all PCI devices including the registers above. Determination of the presence of PnP capable OS is usually made via a switch in the System Setup. However, the final configuration or the existence or not of this switch is implementation dependent.

The ICH5 AC'97 controllers also provide PCI Power Management functionality. PCI Power Management Registers are available via the configuration space. Handling of the Power Management registers is responsibility of the OS PCI Bus driver following standard procedures. For further discussion on the usage model for this registers, refer to Section 3.6, Power Management.

### 3.1.4 Hardware Interrupt Routing

The audio and modem functions in the ICH5 internally share the same PCI IRQ (PIRQB#). The configuration software must take this into account and assign the same IRQ pin to both functions. Sharing IRQs increases the ISR latencies. Each ISR must determine if the interrupting device is the one serviced by the routine, as determined by the OS programming model. PIRQB# it is also exposed as a PCI IRQ.

In an environment where a high Quality of Service (QoS) is required, system designers must pay close attention to devices attached to the same PIRQ. Software driven signal processing functions, as in the case of software driven modem and audio, require maintaining a low latency interrupt service in order to maintain proper functionality. Software driver programmers need to pay close attention to the ISR latencies and make use of Deferred Procedure Calls (DPC) as much as possible.

### 3.1.5 PCI Lock

Note that host controllers are not required to support exclusive-access mechanisms (such as PCI LOCK) for accesses to the memory-mapped register space. Therefore, if software attempts exclusive-access mechanisms to the AC '97 host controller memory-mapped register space, the results are undefined.



## 3.2 DMA Engines

The ICH5 AC '97 controller uses a scatter gather mechanism to access memory. There are five, 16-bit DMA engines for Audio: 2 PCM Stereo In, 2 MIC mono in, and S/P DIF Out. There is one, 20-bit PCM 2/4/6 channel surround DMA engine. There are two, 16-bit DMA engines for Modem: In and Out. Audio and Modem registers are located in two separate PCI functions in the ICH5 components to allow for driver development flexibility.

### 3.2.1 Buffer Descriptor List

The Buffer Descriptor List (BDL) allows device drivers to program DMA transfer using the ICH5 controller. The BDL is an array of up to 32 entries, each of which describes a data buffer. Each entry contains a pointer to a data buffer, control bits and the length expressed as the number of samples contained in the data buffer. The buffer length is restricted to 65535 samples. Samples can be either 16 or 20 bits. Refer to section 3.4.1, for more details on the layout of samples in the data buffer. A value of "0" in the buffer length indicates **no samples** to process. Each descriptor can point to a buffer of a different size.

Figure 3. Generic Form of Buffer Descriptor (One Entry in the List)

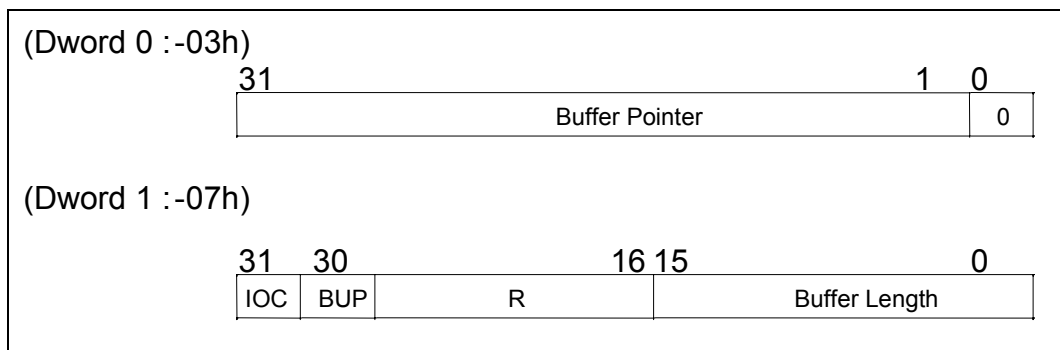

Table 5. BD Buffer Pointer (DWORD 0: 00-03h)

Bit	Description
31:1	<b>Buffer pointer.</b> This field points to the location of the data buffer. Since the samples can be as wide as 1 word, the buffer needs to be aligned to word boundaries to avoid having samples straddle DWord boundaries.
0	<b>Reserved.</b> Must be 0 when writing this field.

**Table 6. BD Control and Length (DWORD 1: 04-07h)**

Bit	Description
31	<b>Interrupt on Completion (IOC)</b> 1= Enable , 0 = Disable. When this is set, it means the controller should issue an interrupt upon completion of this buffer. It should also set the IOC bit in the status register.
30	<b>Buffer Underrun Policy (BUP)</b> 0 = When this buffer is complete, if the next buffer is not yet ready, (last valid buffer has been processed) then continue to transmit the last valid sample. 1 = When this buffer is complete, if this is the last valid buffer, transmit zeros after this buffer is completely processed. This bit will typically be set only if this is the last buffer in the current stream.
29:16	<b>Reserved.</b> Must be 0 when writing this field.
15:0	<b>Buffer length.</b> This is the length of the data buffer in number of samples. The controller uses this data to determine the length of the buffer in bytes. A value of 0 indicates <u>no sample</u> to process.

### 3.2.2 DMA Initialization

The maximum length of the buffer descriptor list is fixed at 32 (this is limited by the size of the index registers). Figure 4, below, describes the organization of the Buffer Descriptor List.

**Figure 4. Buffer Descriptor List**

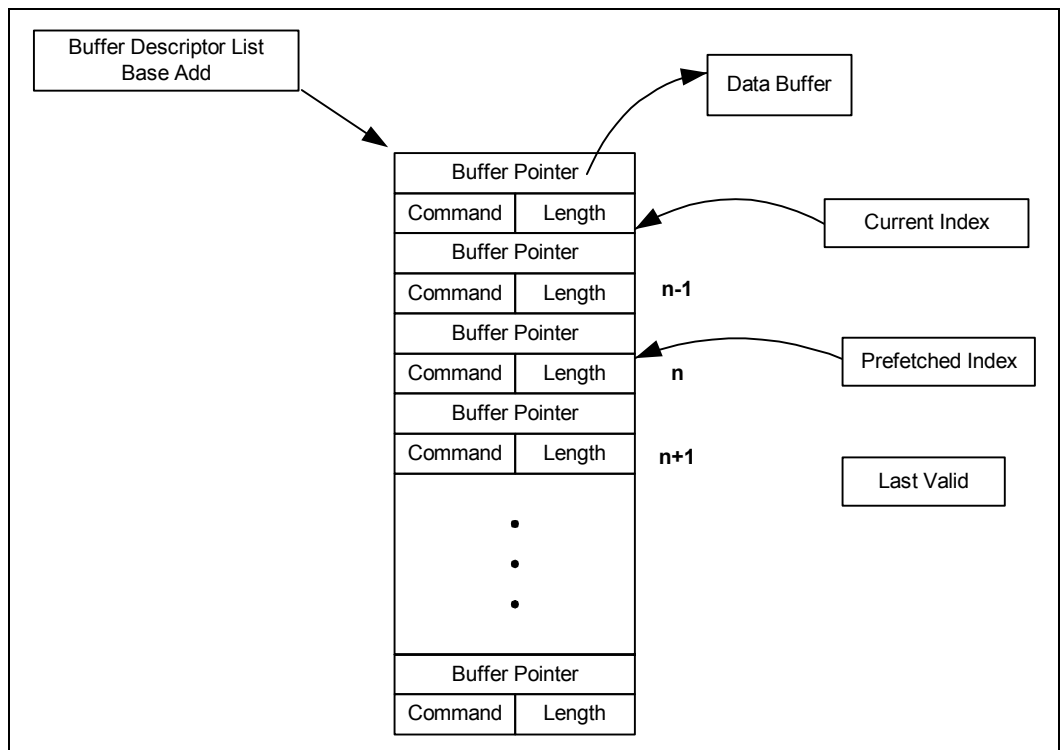

The following steps describe the driver initialization process for a single DMA engine. The same process should be repeated for each DMA engine.

1. Create the buffer descriptor list structure in non-pageable memory.
2. Write the Buffer Descriptor List Base Address register with the base address of the buffer descriptor list.

**Table 7. Audio Descriptor List Base Address**

Audio Buffer Descriptor List Base Address	I/O Address:
PCM IN	MBBAR + 00h (PIBAR)
PCM OUT	MBBAR + 10h (POBAR)
MIC	MBBAR + 20h (MCBAR)
MIC 2	MBBAR + 40h (M2DBAR)
PCM2 IN	MBBAR + 50h (PI2BAR)
SPDIF	MBBAR + 60h (SPBAR)

**Table 8. Modem Descriptor List Base Address**

Modem Buffer Descriptor List Base Address	I/O Address:
Line IN	MBAR + 00h (MIBDBAR)
Line OUT	MBAR + 10h (MOBDBAR),

3. Set up the buffer descriptors and their corresponding buffers. Buffers are usually passed to the device driver as a list of descriptors that reference physical pages. These lists describe the physical page numbers associated with the pages in the virtual audio buffer. Multiple buffer descriptors may be required to represent a single virtual buffer passed to the device driver
4. Once buffer descriptors are set in memory, software writes the Last Valid Index (LVI) register.

**Table 9. Audio Last Valid Index**

Audio Last Valid Index (LVI)	I/O Address:
PCM IN	MBBAR + 05h (PILVI),
PCM OUT	MBBAR + 15h (POLVI),
MIC	MBBAR + 25h (MCLVI)
MIC 2	MBBAR + 45h (M2LVI)
PCM2 IN	MBBAR + 55h (PI2LVI)
SPDIF	MBBAR + 65h (SPLVI)

**Table 10. Modem Last Valid Index**

Modem Last Valid Index (LVI)	I/O Address:
Line IN	MBAR + 05h (MILVI)
Line OUT	MBAR + 15h (MOLVI),

5. After LVI registers are updated, software sets the run bit in the control register to execute the descriptor list.

### 3.2.3 DMA Steady State Operation

Software has two concurrent activities to perform while in normal operation: Preparing new buffers/buffer descriptors and marking processed buffer descriptors and buffers as free. Once the run bit is set in the bus master control register bit 0, the bus master fetches the buffer descriptor.

1. Bus master starts processing the current buffer. Once current buffer is processed, depending upon the bits set in the command field, the interrupt is asserted and the interrupt bit is set.
2. Bus master increments the current and pre-fetch indices. It then starts executing the current buffer and schedules the next buffer to be pre-fetched.
3. Buffer service routine maintains a variable that points to the head of the list of descriptors to be processed. The descriptor list service routine performs the following activities:

```
// Update head of descriptors to be processed
While (head != current_index)
{
    Mark head free ;
    // check for end of descriptor list
    If head == base_address + (31 * 8);
        // last entry on the list, set head to top of the list
        head = base_address;
    Else
        // still inside the list, increment head to next entry
        head++;
}
```

**Caution:** This algorithm needs to be optimized to reduce the number of memory accesses during execution. The “while” statement could translate to several memory access if this code is not execute after each buffer descriptor update.

Also, the routine that prepares buffers maintains a variable that points to the entry *after* the tail of the list. This value is always the next entry after the Last Valid Index register. It follows the following algorithm:

```
// Update tail of descriptor list ready for execution and audio
// buffers when available for processing
While ((tail == free) && (buffers_available > 0))
{
    Prepare buffer descriptor indexed by tail;
    buffers_available--;
    //assign tail to Last Valid Index
    LVI = Tail;
    // check for end of descriptor list
    If (tail == base_address + 31 * 8);
        // last entry on the list, set tail to top of the list
        tail = base_address;
    Else

```



```
        // Advance tail to next value  
        tail++;  
    }
```

### 3.2.4 Stopping Transfers

There are two ways that DMA transfers can be stopped.

1. By simply turning off the Bus Master run/pause bit. This will halt the current DMA transfer immediately. Data in the output FIFOs will continue to be read out until they empty. The registers will retain their current values and AC-link corresponding slots will be invalidated. Setting the run/pause bit will resume DMA activity.
2. Software can stop creating new buffers and hence not update the last valid index register. The bus master will stop once the last valid buffer has been processed. All register information is maintained. During this condition the controller will transmit the last valid sample or zeros pending the status of the Buffer Underrun Policy (BUP) bit in the buffer descriptor entry. If the run/pause bit remains set, then any future update to the Last Valid Index register will cause the bus master operation to resume.

**Note:** Software must ensure that the DMA controller halted bit is set before attempting to reset registers.

### 3.2.5 FIFO Error Conditions

Two general conditions could result in the FIFO error bit 4 in the status register being set. Pending the status of bit 3 in the control register it will also cause an interrupt.

#### 3.2.5.1 FIFO Underrun

FIFO underrun will occur when the ICH5 AC '97 controller FIFO is drained:

1. As a result of system congestion. The DMA read transaction could still be pending as data has not returned from memory. In this case the controller will repeat last sample until new data is available in the FIFO.
2. As a result of DMA engine reaching the Last Valid Index, no further access to memory, therefore FIFO will drain. In this case the controller will transmit the last valid sample or zeros pending the status of the Buffer Underrun Policy (BUP) bit in the buffer descriptor entry. This condition is an error if software is not able to update the descriptor list before the DMA engine reaches the Last Valid Index. However, this condition could be as result of the completing processing the last buffer. It is up to the software driver to determine the final status of this condition. See also Stopping Transfers, Section 3.2.4.

#### 3.2.5.2 FIFO Overrun

FIFO overrun will occur when valid data is transmitted in proper AC-link slots and DMA FIFO remains full. Two conditions could result in the FIFO error bit 4 in the status register being set. Pending the status of bit 3 in the control register it will also cause an interrupt.

1. As a result of DMA engine not being able to update system memory with the content of the FIFO. This is a result of system congestion. In this case, all new samples received from the AC-link will be lost.



2. As a result of the DMA engine reaching the Last Valid Index, no further access to memory, therefore FIFO will not drain. This condition is an error if software is not able to update the descriptor list before the DMA engine reaches the Last Valid Index. However, this condition could be the natural result of the last buffer entry been processed. It is up to the software driver to determine the final status of this condition. See also Stopping Transfers in paragraph above.

## 3.3 Channel Arbitration

It is possible for up to eight ICH5 AC '97 DMA channels to be enabled at one time. A round-robin arbitration scheme is used to arbitrate between these channels.

## 3.4 Data Buffers

### 3.4.1 Memory Organization of Data

Samples are packed in an interleaved format: two samples for two channel (stereo), four samples for four channels surround and six samples for six channels surround.

The actual PCM data is "left-aligned" within the container. The sample itself is justified most significant; all extra bits are at the least-significant portion of the container. All non-valid data bits must be set to 0. With 20 bit data, the "top" 20 bits (31-12) of the DWORD contain the data. The bottom 12 bits (11-0) are not valid data. The sample data must be WORD aligned.

### 3.4.2 PCM Buffer Restrictions

Below are the memory buffer restrictions for ICH5 PCM that applies for 2-, 4-, and 6-channel audio mode:

1. Buffer Descriptors Must Contain Integer Multiples of Framed Samples and Are Frame Aligned:

Example: Two channel buffers must contain an integer multiple of two samples. Four channel buffers must contain a multiple of four samples and six channel buffers must contain a multiple of six samples. The controller does not support a frame (e.g., left and right samples for two channel) spanning multiple descriptors. Similarly, the controller does not support a buffer descriptor with a single sample (PCM out MONO is not supported). Also, odd length buffers are not allowed due to the sample alignment requirements.

2. Software Is Allowed to Create an Empty Frame (0 Samples) in a Buffer Descriptor with the Following Restriction:

An empty buffer has to be part of a list of buffer descriptors and it cannot to be the first Buffer Descriptor or the last Buffer Descriptor of the list. A series of buffer descriptors with 0 samples are possible in the lists as long as they are not the first or the last. The last Buffer Descriptor in the list is determined by the last valid index (LVI) that is programmed.



### 3.4.3 FIFO Organization

The ICH5 AC '97 controller supports 16-bit samples on all channels except PCM Out, which also supports 20-bit samples.

Data will be written to the FIFO in sample pairs following the order of valid slots in a channel. For example, for audio PCM In, the controller will check the first valid slot and add it to the FIFO first entry as a word (16 bits). The next valid slot will be added as the second word entry in the FIFO to create the PCM stereo sample pair. This behavior works under the assumption that the first valid slot will be always the Left channel (slot 3) followed by Right channel in slot 4 in the same or subsequent frame. If the codec transmits data repeating the slot, it will cause the controller to misplace the sample in the FIFO. Codecs compatible with the ICH5 AC '97 implementation should always maintain the indicated order, and never use the same slot twice to transmit samples to the controller. The figures below present some ICH5 compatible and incompatible implementations using as a reference a two-channel implementation.

**Figure 5. Compatible Implementation with Left and Right Sample Pair in Slot 3/4 Every Frame**

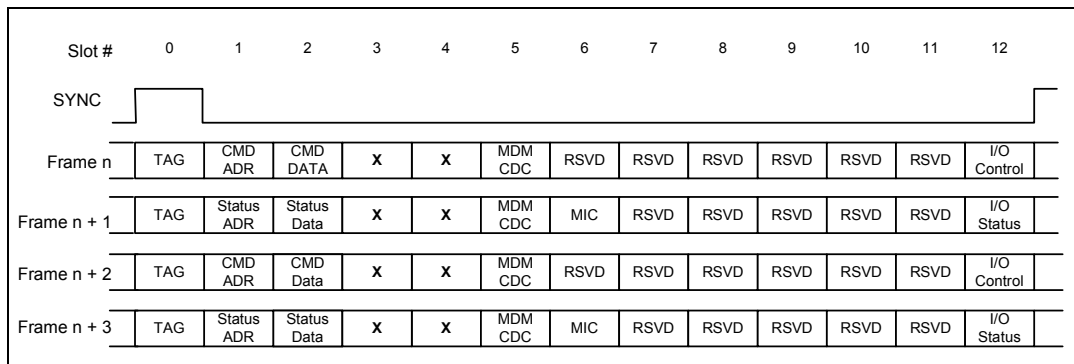

**Figure 6. Compatible Implementation with Sample Rate Conversion Slots 3 and 4 Alternating over Next Frame**

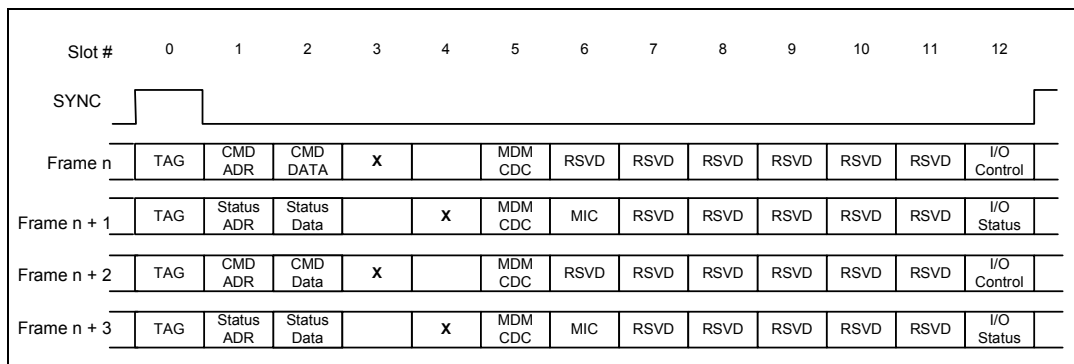

**Figure 7. Incompatible Implementation of Sample Rate Conversion with Repeating Slots over Next Frames**

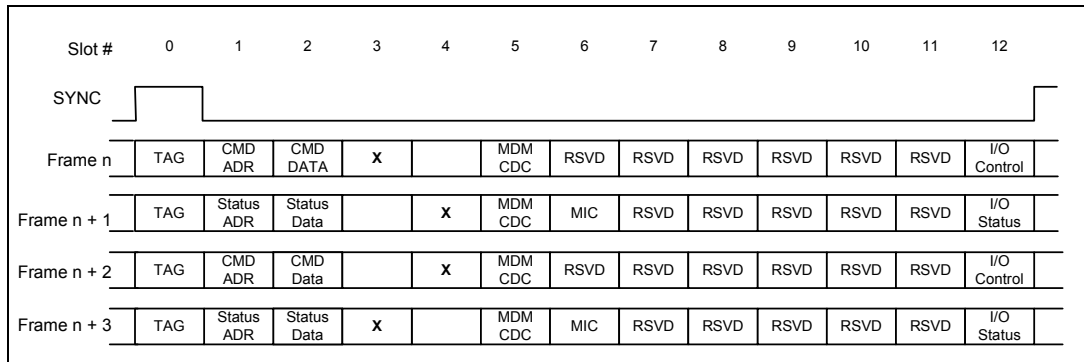

**Table 11. FIFO Summary**

Channel	# of Samples	FIFO Depth	FIFO Width	Comments
Mic In	1	2	32 bits	2 frame <sup>1</sup> dword
Mic2 In	1	2	32 bits	2 frame <sup>1</sup> dword
PCM In	2	4	32 bits	1 frames per dword
PCM2 In	2	4	32 bits	1 frames per dword
PCM Out	6, 4 or 2	24	32 bits	1 frames per dword (2 –16 bits ch), 1 frame per 2 dword (2 –20 bits ch) 1 frame per 2 dword (4 –16 bits ch) 1 frames per 4 dword (4 –20 bits ch) 1 frames per 3 dword (6 – 16 bits ch.) 1 frames per 6 dword (2 –20 bits ch)
Modem In	1	2	32 bits	2 frames per dword
Modem Out	1	2	32 bits	2 frames per dword

**NOTES:**

1. One audio frame worth of data for the specific DMA channel.

### 3.5 Multiple Codec/Driver Support

The ICH5 AC '97 controller is capable of supporting a three-codec implementation. Under this implementation all codecs share the SDATA\_OUT signal while independent SDATA\_IN[0:2] are used by the codec to supply data to the controller. ICH5 allows for a compatible behavior, where the three SDATA\_IN are used, these signals are logically OR'd inside the digital controller, effectively creating one digital input data stream. However, ICH5 also allows for an independent SDATA\_IN functionality. In this case, the SDATA\_IN Map Register (SDM) MBBAR + 80h is used to steer the content of the input slots to the appropriate controller DMA engine. This capability also allows for a more reliable enumeration algorithm of the available codecs.

Table 12. SDM Register Description

Bit	Type	Reset	Description
7:6	RW	00	<p>PCM In 2, Microphone In 2 Data In Line (D21L): When the SE bit is set, these bits indicate which SDATA_IN line should be used by the hardware for decoding the input slots for PCM In 2 and Microphone In 2. When the SE bit is cleared, the value of these bits is irrelevant, and PCM In 2 and Mic In 2 DMA engines are not available.</p> <p>00 SDATA_IN0 01 SDATA_IN1 10 SDATA_IN2 11 Reserved</p>
5:4	RW	00	<p>PCM In 1, Microphone In 1 Data In Line (D11L): When the SE bit is set, these bits indicates which SDATA_IN line should be used by the hardware for decoding the input slots for PCM In 1 and Microphone In 1. When the SE bit is cleared, the value of these bits are irrelevant, and the PCM In 1 and Mic In 1 engines use the OR'd SDATA_IN lines.</p> <p>00 SDATA_IN0 01 SDATA_IN1 10 SDATA_IN2 11 Reserved</p>
3	RW	0	<p>Steer Enable (SE): When set, the SDATA_IN lines are treated separately and not OR'd together before being sent to the DMA engines. When cleared, the SDATA_IN lines are OR'd together, and the "Microphone In 2" and "PCM In 2" DMA engines are not available.</p>
2	RO	0	Reserved
1:0	RO	00	<p>Last Codec Read Data Input (LDI): When a codec register is read, this indicates which SDATA_IN the read data returned on. Software can use this to determine how the codecs are mapped. The values are:</p> <p>00 SDATA_IN0 01 SDATA_IN1 10 SDATA_IN2 11 Reserved</p>

### 3.5.1 Codec Register Shadowing

Codec register reads are presented in the AC-link in the next available frame after the controller receives the I/O transaction. Data will be returned to the controller pending codec availability. To avoid longer latencies than necessary, the codec must return data in the next available frame. Multiple frame transactions impose large system latencies, to the detriment of system performance.

Even when data is returned in the frame immediately after the read request is presented in the AC-link, the minimum latency is still on the order of 40  $\mu$ s. To minimize the effect on the system caused by long latencies in the AC-link, software drivers **must** maintain a copy of the codec register in memory (shadow) and use this data instead of accessing the codec.

Shadowing in memory is effective as long as the codec itself does not change the value of the registers. Therefore, the status of the GPIOs configured as inputs on the most recent frame is accessible to software by reading the register at offset 54h in the modem codec I/O space. Only the 16 MSBs are used to return GPI status. Reads from 54h will not be transmitted across the link. Instead, data received in slot 12 is stored internally in the controller, and the data from the most recent slot 12 is returned on reads from offset 54h.

The Powerdown in codec offset 26h and 3Eh status registers are not supported by an automatic shadowing mechanism, as is the case for offset 54h. However, these registers are sparingly used. These registers are read only during power down status determination.

Finally, codec ready status is required during system initialization. It is automatically reflected in the Global Status Register at MBBAR + 30h (*MBAR + 40h*) bit 8 for the SDATA\_IN0 codec, bit 9 for the SDATA\_IN1 codec and bit 28 for the SDATA\_IN2 codec. These three bits need not be saved in memory.

### 3.5.2 Codec Access Synchronization

All codec register writes are posted transactions in the ICH5 AC '97 controller. The ICH5 AC '97 controller will indicate transaction completion to the host processor immediately following the request even when the transaction is actually pending for completion in the AC-link. This is done to improve system performance. However, it also imposes restrictions in the driver(s) operation. Also, register reads present synchronization issues.

Before a codec register access is initiated, the driver must check the status of the Codec access in Progress (CAIP) bit 0 in the Codec Access Register at *MBBAR + 34h (MBAR + 44h)*. If no write is in progress, this bit will be '0' and the act of reading the register sets this bit to '1'. This reserves the driver the right to perform the I/O read or write access. Once the write is complete, hardware automatically clears the bit. The driver must also clear this bit if it decides not to perform a codec I/O write after having read this bit. If the bit is already set, it indicates that another driver is performing a codec I/O writes across the link and the driver should try again later.

### 3.5.3 Data Request Synchronization in Audio Split Configurations

To support more than 2 channels of audio output, the *AC '97 Component Specification, Revision 2.1* allows for a configuration where up to three audio codecs work concurrently to provide surround capabilities (refer to *AC '97 Component Specification, Revision 2.3*) To maintain data on demand capabilities the Intel controller, when configured for 4 or 6 audio channels, will wait for all the appropriate Slot Request bits to be set before sending data in the SDATA\_OUT slots. This allows for a simple FIFO synchronization of the attached codecs.

If the codecs on the link are not compatible, or are not known to be compatible, with respect to sample rate conversion algorithms and FIFO depth requirements (for instance, all codecs being the same revision of the same model from the same vendor), Variable Rate support should not be used, and a fixed sample rate of 48 MHz is recommended to maintain synchronization across the codecs in use.

## 3.6 Power Management

Power management of the driver/codec interaction requires careful sequencing in the ICH5 AC '97 environment. In the ICH5 AC '97 environment it is possible to have two drivers sharing the same AC-link interface for two separate codecs or a single driver controlling two separate audio codecs. A driver forcing an aggressive sleep state in the link could have functional repercussions on the pairing codec. The Deep Sleep state in a device following ACPI compliance requirements is the D3 State. When a driver is requested to set its device to the D3 State, the driver should enter the most aggressive power saving mode possible. The D3 State is also often the precursor to a system wide core power removal. Therefore several considerations must be taken into account to maintain the device functionality and wake-up capability.

### 3.6.1 Codec Topologies

The procedure to be taken by an ICH5 AC '97 device driver varies depending on the system configuration. The following table enumerates the possible codec combinations supported by the ICH5 AC '97 controller.

The ICH5 audio/modem controller supports a maximum of three codecs. If there is more than one audio codec, then the remaining codecs must proceed to the different power states at the same time. The following system implementations are possible.

**Table 13. Dual Codecs Topologies**

Config.						
1	AC	(Primary)				
2	MC	(Primary)				
3	AMC	(Primary)				Possible D3 state interactions
4	AC	(Primary)	+	MC	(Secondary)	Possible D3 State interactions
5	AC	(Primary)	+	AC	(Secondary)	Driver interaction concern
6	AMC	(Primary)	+	AC	(Secondary)	Possible D3 State Interactions
7	AC	(Primary)	+	AMC	(Secondary)	Possible D3 State Interactions

**Note:** The configuration above could be further limited by ICH5 AC '97 riser card configuration and loading. Refer to the *Audio/Modem I/O Riser Specification* for details.

It is evident that Configurations 1 and 2, above, require no driver synchronization between ICH5 AC '97 codecs. Configuration 1 and 2 are single codec topologies, and therefore an aggressive power saving mode is possible including disabling of the actual AC-link without concern of affecting paired codec functionality.

Configuration 3 is a single codec topology that provides both functions audio and modem. In this configuration driver interaction is also critical if a separate set of drivers are in control of the audio and modem functions.

Configuration 4, however, is a two-codec topology. In this configuration an aggressive power saving mode requires detailed attention to cross interactions and the effect on AC-link functionality.

Configuration 5 is a two-codec audio topology. In this configuration concerns are on the proper power down sequence. However, no driver interaction is expected as only the audio driver executes power management functions.

Configuration 6 is also a two-codec topology with split audio and integrated modem support. This is the most complex interaction, as two different sets of driver will be operating in a complex topology.

Configuration 7 is identical to configuration 6, with the primary and secondary codecs switched.

In order to power manage ICH5 AC '97 codecs, there are two sets of PR bits that drivers need to manage. One set is at offset MMBAR + 26h in the audio function, mapped to offset 26h in the primary codec, and the second set is at MMBAR + 3Eh, mapped to offset 3Eh in the modem function. Notice that register 3Eh does not provide link down functionality, this is provided in register 56h bit 12, (MLNK) modem link.

### 3.6.1.1 Tertiary Codec Topologies

Table 12 lists configurations using a primary and secondary codec. ICH5 also supports configurations involving a third (tertiary) codec. It is important to note that three codec configurations are an extension of the corresponding two codec versions and have the same D3 interactions and issues. Therefore, the configurations, algorithms and pseudo-code described for the secondary codec also apply and can be used for configurations that involve three codecs.

## 3.6.2 Power Management Transition Maps

The following paragraphs relate power management transition maps in the constraints of an ACPI system environment. The tables below map codec PR bits transitions to specific ACPI “D” states for the device.

The following considerations were made in the generation of the following tables:

- Power management is defined in the framework of a desktop system. Further power savings are possible by implementing more aggressive power management typical of mobile environment policies (see aggressive power management section below). However these power savings are a trade off involving driver complexities and functional restrictions.
- Selection of a specific power policy below is pending the proper identification of the topology by the driver(s).
- Secondary codec is provided with external clocking mechanism and is not dependent on BIT\_CLK to drive internal state machines when in power down mode.
- After warm or cold reset the device driver will bring all PR(x) bits to D0 state.
- Transition from/to any Dx state is accomplished by setting/resetting all appropriate PR(x) bit simultaneously. Codec should not place limitations on the PR(x) bits transition sequence represented above.
- Audio Codec Reg. 26h D15 EAPD (formerly PR<7> enable/disable function) is newly defined as control for an external audio power amp. Audio codec should provide an audio amp output pin (GPO) that provides off/on capability following this bit set/reset status.
- The modem tables assume Caller-ID capability during wake-up on ring, so Vref is on during D3.



- Modem D3 configuration is dependent on wake-up on ring event enable. If wake-up on ring is enabled, GPIO cannot go down in D3.

**Note:** When a codec section is powered back on the Powerdown Control/Status register (index 26h) should be read to verify that the section is ready before attempting any further operations.

### Configuration Number 1: Single Audio Codec (Primary):

**Table 14. Power State Mapping for Audio Single or Dual (Split) Codec Desktop Transition**

PR<0:5> + (EAPD)								+12	+5 from +12	+3.3 Digital	+3.3 Vaux Digital	Comments
	E A P D	C L K	AC- Link	Mixer Vref.	Mixer	D A C	A D C					
Device State	7	5	4	3	2	1	0					
D0	0	0	0	0	0	0	0	On	On	On	On	All on
D1	0	0	0	0	0	1	1	On	On	On	On	-DAC, -ADC
D2	1	0	0	0	1	1	1	On	On	On	On	-Mix, -Amp
D3	1	1	1	1	1	1	1	Off	Off	Off	On	-Clock, -Vref

### Configuration Number 2: Single Modem Codec (Primary):

**Table 15. Power State Mapping for Modem Single Codec Desktop Transition**

PR<A:D> + MLNK (other power control (PRx) bits do not apply for Intel® ICH5 implementation)						+12	+5 from +12	+3.3 Digital	+3.3 Vaux Digital	Comments
	Sdata_In	D A C 1	A D C 1	Vref	GPIO					
Device State	MLNK	D	C	B	A					
D0	0	0	0	0	0	On	On	On	On	All on
D1	0	1	1	0	0	On	On	On	On	-DAC, -ADC
D2	0	1	1	0	0	On	On	On	On	Same as D1
D3 (wake-up on ring)	1	1	1	0	0	Off	Off	Off	On	-Sdata_In,
D3	1	1	1	1	1	Off	Off	Off	On	-Sdata_In, -Vref, -GPIO



**Configuration Numbers 3 to 6: Dual Function Single or Dual Codec Configurations:**

**Table 16. Power State Mapping for Audio in Dual Codec Desktop Transition**

PR<0:5> + (EAPD)								+12	+5 from +12	+3.3 Digital	+3.3 Vaux Digital	Comments
	EAPD	CLK	AC-Link	Mixer Vref.	Mixer	DAC	ADC					
Device State	7	5	4	3	2	1	0					
D0	0	0	0	0	0	0	0	On	On	On	On	All on
D1	0	0	0	0	0	1	1	On	On	On	On	-DAC, -ADC
D2	1	0	0	0	1	1	1	On	On	On	On	-Mix, -Amp
D3	1	0	0	1	1	1	1	Off	Off	Off	On	-Clock, -Vref

**NOTES:**

1. PR(4) link down and PR(5) internal clocks disable are NOT recommended for desktop configuration. Setting these to power control bits could affect modem operation in an AC + MC configuration.
2. In a mobile system configuration, PR(4) and PR(5) could be used to provide further power savings. Driver designers should use D3 state codec semaphores in the ICH5 AC '97 controller to determine audio or modem codecs power status before setting PR(4) and PR(5) bits. Please refer to ICH5 AC '97 External Architecture Specification for details. The miniport driver developed for the ICH5 AC '97 controller does not provide this capability.
3. In a dual audio codec transition, PR bits must be set in both of the codec registers. The primary audio power management register set is always located MMBAR + 26h, the secondary audio codec power management register set is located at MMBAR + A6h. Configuration software must sequence power down to the secondary codec first and then the primary codec. The process is reversed at resume when the primary codec is first restored and then the secondary.

Table 17. Power State Mapping for Modem in Dual Codec Desktop Transition

PR<A:D> + MLNK (other power control (PRx) bits do not apply for Intel® ICH5 implementation)						+12	+5 from +12	+3.3 Digital	+3.3 Vaux Digital	Comments
	Sdata_In	D A C 1	A D C 1	Vref	GPIO					
Device State	MLNK	D	C	B	A					
D0	0	0	0	0	0	On	On	On	On	All on
D1	0	1	1	0	0	On	On	On	On	-DAC, -ADC
D2	0	1	1	0	0	On	On	On	On	Same as D1
D3 (wake-up on ring)	1	1	1	0	0	Off	Off	Off	On	-Sdata_In,
D3	1	1	1	1	1	Off	Off	Off	On	-Sdata_In, -Vref, -GPIO

Table 15 and Table 16 above, represent the recommended Power Transition Tables for a Desktop System. The tables above preclude the need for a driver to provide codec topology detection simplifying the initialization sequence. These tables do not provide the maximum power saving. However, they are believed to provide sufficient power saving for the Desktop applications. The OEM and IHV are free to provide further differentiation by allowing the deeper power savings obtained by identifying the codec Topology.

### 3.6.3 Power Management Topology Considerations

A set of drivers could always assume Configuration Numbers 3 and 4, above, and establish their power management policy based on Table 15 and Table 16. These are the safest configurations with a semi-aggressive power management style consistent with a desktop environment. However, even in a desktop environment, further power savings are possible when in Single Codec Configurations Numbers 1 and 2. For the tables above to be implemented, the audio driver needs to be able to determine the AC-link topology configuration.

#### 3.6.3.1 Determining the Presence of Secondary and Tertiary Codecs

To determine that optional secondary and tertiary codecs are present, the driver needs to check three Codec Ready bits located in the Global Status Register at:

Codec Ready: I/O Address:  $MBBAR + 30h$  ( $MBAR + 40h$ ) bits 8,9,28

If two of these three bits are set to 1, it indicates that a secondary codec is active in the AC-link.

If all three of these bits are set to 1, it indicates that a tertiary codec is active in the AC-link.



### 3.6.3.2 Determining the Presence of a Modem Function

In the case of an AMC configuration, only the primary codec ready bit will be indicated. In order to determine proper power down configuration, the audio driver needs to determine the presence of modem functionality in the codec. The audio driver could check the Extended Modem ID register at:

*Extended Modem ID: I/O Address: MMBAR + 3Ch*

The content of this register will be FFh if no modem function is present.

### 3.6.4 Resume Context Recovery

When the system is placed in a powerdown state (S3 or greater) power is removed from the ICH5 AC '97 controller. In this state DMA registers lose information regarding current position and pointer values. The device driver must be able to save the context of all DMA engines before acknowledging a D3 state. Device drivers must assume that D3 state request precedes a total system powerdown causing context for the DMA engines to be lost. Upon system power resume, the device driver must restore the DMA engine registers to the values saved prior to the suspend event.

### 3.6.5 Aggressive Power Management

As indicated in previous sections it is possible to go into a more aggressive power savings mode by carefully synchronizing audio and modem driver interactions over the AC-link. This aggressive power savings is usually found in mobile environments where battery power is critical.

Driver synchronization is required in a dual codec configuration where the audio driver could cause a link down power condition by setting the PR4 and PR5 bits in the audio codec register. When PR4 and PR5 are set, the AC-link base clock BIT\_CLK is stopped. If this action occurs while the modem codec is still in operating mode, it will cause malfunctions and possibly a system hang.

To avoid this and similar situations, the audio and modem driver could follow a protocol using the provided audio and modem D3 state bit semaphores, AD3 for audio and MD3 for modem. These bits are located at:

*Codec Write Semaphore Registers:*

*NABMAR + 30h Audio I/O Space and MBAR + 40h Modem I/O Space*

*bit 16 for Audio (AD3)*

*bit 17 for Modem (MD3)*

ICH5 AC '97 drivers should set the appropriate bit after setting the codec in a D3 state. The audio codec could use this semaphore to determine if the modem codec is already in a D3 state and shut down the link by also asserting PR4 and PR5 in the power management register in the audio function/codec. The following sections review in detail the sequence of events for drivers/codec entering a D3 state and a resume to D0.

### 3.6.5.1 Primary Audio Requested to D3

The audio power management procedure attempting to get the audio codec to D3 state.

```

If MD3 == true                                // (sleeping?)
{
    Audio_Power_Manage_Reg = D3 + PR4 + PR5;
    // yes, sleep plus AC Link down
}
Else
{
    Audio_Power_Manage_Reg = D3;    // No, sleep keeping link up
}
AD3 = true;                                  // set to "audio sleeping"
// setting the flag last avoids race condition during
// D0->D3 transition.

```

### 3.6.5.2 Secondary Modem Requested to D3

The modem power management procedure will try to get the modem codec to D3 state.

```

Secondary_codec = D3 + MLNK // yes, sleep plus SDATA_IN1 low
MD3 = true

// setting the flag last avoids race condition during D0->D3
// transition.
// MLNK corresponds to register Reg. 56h bit 12 (D12)

```

### 3.6.5.3 Secondary Modem Requested to D0

The modem power management procedure will try to get the modem codec to D0 state.

```

MD3 = false                                // set to "modem awake"

// Setting the flag first avoid race condition during D3->D0
// transition
If Modem_ready == True
{
    Modem_Power_Manage_Reg = D0    // Bring back to fully awake,
}
If AD3 == true                              // (audio sleeping?)
{
    Link_reset()                        // cause a warm or cold reset
    While (!Modem_ready)                // wait for modem ready
    {
        read modem codec ready bit every 400 ms
    }
    Modem_Power_Manage_Reg = D0    // Bring back to awake,
}

```

### 3.6.5.4 Audio Primary Requested to D0

The audio power management procedure will attempt to get the audio codec to D0 state.

```

AD3 = false // set to "audio awake"

// Setting the flag first avoid race condition during D3->D0
// transition
If Audio_ready == True
{
    Audio_Power_Manage_Reg = D0;
    // Bring back to fully awake,
}
If MD3 == true; // (modem sleeping?)
{
    Link_reset(); // cause a warm or cold reset
    While (!Audio_ready); // wait for modem ready
    {
        read audio codec ready bit every 100ms;
    }
    Audio_Power_Manage_Reg = D0; // Bring back to awake,
}
  
```

### 3.6.5.5 Using a Cold or Warm Reset

In the pseudo code above there are several references to resetting the AC-link using “Link\_reset()”. Drivers need to differentiate if the system enters a suspend event where core power is removed from the system before deciding to execute a Cold or Warm reset. A device is in a “D3 hot” state after the device is set in the lowest power consumption mode and core power is maintained. A device is in a “D3 cold” state when the device is set in the lowest power consumption mode and core power is removed.

In the ICH5 AC '97 implementation when core power is removed the cold reset bit is reset “0” This bit is located at:

*MBBAR + 2Ch and MBAR + 3Ch*

**bit 1 ICH5 AC '97 Cold Reset#.**

A driver requested to resume to a D0 state from a D3 state must check the status of the ICH5 AC '97 cold reset bit. If this bit has a value of “0” the driver will set it to “1” to de-assert the AC\_RESET# signal in the link, thus completing a cold reset. If the Cold Reset bit is set to “1” then a warm rest is required if the AC-link is down by the procedures indicated under aggressive power management. To execute an ICH5 AC '97 warm reset the driver must set to “1” the ICH5 AC '97 warm reset bit located at:

*MBBAR + 2Ch and MBAR + 3Ch*

**bit 2 ICH5 AC '97 Warm Reset#**



A pseudo code representation is as follows:

```
void Link_reset(void)
{
    If Cold_Reset# == True    // AC_RESET# asserted, D3 when cold!
    {
        Cold_Reset# = False; // De-assert AC_RESET# Wake-up!
    }
    Else
    {
        Warm_reset = True;    // D3 is Hot! Do warm reset
    }
}
```

## 4 Surround Audio Support

The *AC '97 Component Specification* allows for up to six channels of audio supported in the AC-link. The audio device driver must determine the number of audio channels available in the codec(s) and properly enable the ICH5 AC '97 controller to support those channels in the link.

### 4.1 Determine Codec's Audio Channels

Upon determination of the link topology, system software must proceed to resolve the total number of audio channels available in the codec(s). *Appendix A* of the *AC '97 Component Specification, Revision 2.1* defines codec register index 28h to indicate the presence of surround, center and LFE channels as follows: *Extended Audio ID Register (Index 28h)*.

**Table 18. Extended Audio ID Register**

Bit D6:	CDAC=1 indicates optional PCM Center DAC is supported
Bit D7:	SDAC=1 indicates optional PCM Surround L and R DACs are supported
Bit D8:	LDAC=1 indicates optional PCM LFE DAC is supported
Bit D9:	AMAP=1 indicates optional slot/DAC mappings based on Codec ID (Refer to the <i>AC '97 Component Specification, Revision 2.1, Appendix D</i> for description)
Bit D15-D14:	ID1, ID0 is a 2-bit field which indicates the Codec configuration: Primary is 00; Secondary is 01, 10, or 11 (Refer to the <i>AC '97 Component Specification, Revision 2.1 Appendix C</i> for details)

The *AC '97 Component Specification, Revision 2.3, Section 5.8.2*, provides detailed information on the usage model for multiple audio channels. This specification assumes the proper use of the AMAP bit describes the partition of the channels exposing critical functionality. If AMAP bit is not set to "1" a generic driver will not be able to determine the proper codec to slot distribution for a split audio codec configuration.

Based on Table 32 of the *AC '97 Component Specification, Revision 2.3*, the following table describes the available codec topology to audio channel distribution for ICH5 AC '97 controller.

**Table 19. Single Codec Audio Channel Distribution**

Single Audio Codec Configuration	
Primary	Total Audio Channels
L/R	2
L/R; S-L/R	4
L/R; S-L/R; C/LFE	6

Table 20. Multiple Codec Audio Channel Distribution

Split Audio Codec Configuration			
Primary	Secondary	Tertiary	Total Channels
L/R	-	-	2
L/R	S-L/R	-	4
L/R	S-L/R; C/LFE	-	6
L/R	S-L/R	C/LFE	6

**Legend:**

L/R: Left Stereo Channel (Slot 3); Right Stereo Channel (Slot 4)  
 S-L/R: Surround Left Channel (Slot 7); Surround Right Channel (Slot 8)  
 C/LFE: Center Channel (Slot 6); Low Frequency Enhancement “subwoofer” (Slot 9)  
 (-): Not Applicable for this configuration could be used for simultaneous S/PDIF output

## 4.2 Enabling Intel® ICH5 AC '97 Controller Audio Channels

The ICH5 indicates how many channels supports in its Global Status Register. The ICH5 AC '97 controller defaults to PCM stereo after system reset or suspend-resume from S3, S4 or S5. Audio drivers can determine the total number of channels and re-configure the controller to support either 4 or 6 channel audio for PCM Out only. PCM In and PCM2 In are not configurable and are always set for 2 -channel input. PCM MIC In and PCM2 MIC In are also not configurable and are always single channel (monaural.) The total numbers of audio channels supported are indicated at: *MBBAR + 30h: Global Status Registers.*

Table 21. CM 4/6 –PCM Channels Capability Bits

Bit	Description
21:20	<b>PCM 4/6 Capability:</b> These read-only bits indicate the capability to support more than 2 channels for the PCM OUT. These bits will both be 1 to indicate that the Intel® ICH5 supports both 4 and 6-channel PCM output.

The ICH5 AC '97 controller also provides support for an independent DMA channel to provide simultaneous S/PDIF output stream. This allows for concurrent PCM surround out with AC3 compress over S/PDIF interface. ICH5 AC '97 controller follows slot assignments described in Section 5.4.2.1 and Table 13 of the *AC '97 Component Specification, Revision 2.3.*

System software enables the number of channels it intends to provide to the codec at: *MBBAR + 2Ch: Global Control Registers.*



**Table 22. AC-Link PCM 4/6 -Channels Enable Bits**

21:20	PCM 4/6 Enable: Enables the PCM Output to be in 4 channel or 6-channel mode.	PCM Slots Enable: (PCM OUT DMA)	S/PDIF Slots Enable: (S/PDIF Out DMA)
	00 = 2 channel mode (default).	3, 4 (L and R)	7, 8
	01 = 4 channel mode.	3, 4, 7, 8 (L, R, RL and RR)	6, 9
	10 = 6 channel mode	3, 4, 7, 8, 6, 9 (L, R, RL, RR, C and LFE)	10, 11
	11 = Reserved	(undefined)	(undefined)



This page is intentionally left blank.

## 5 20-Bits PCM Support

The ICH5 AC '97 controller provides support for 16- or 20-bit PCM out. Software can determine if 20-bit samples are supported in the controller by reading the sample capabilities bits in GLOB\_STA registers as follows: *MBBAR + 30h: Global Status Registers*.

**Table 23. Sample Capabilities**

Bit	Description
23:22	<p><b>Sample Capabilities:</b> Indicates the capability to support greater than 16-bit audio.</p> <p>00 = 16-bit Audio only supported (ICH1, ICH2, and ICH3 value)</p> <p>01 = 16 and 20-bit Audio supported (ICH5 value)</p> <p>10 = Reserved (for 24-bit audio support)</p> <p>11 = Reserved</p>

After determination of the controller capabilities, software can enable 20 –bits formats by programming the GLOB\_CNT register as follows: *MBBAR + 2Ch: Global Control Registers*.

**Table 24. PCM Out Mode Selector**

Bit	Description
23:22	<p><b>PCM Out Mode (POM):</b> Enables the PCM out channel to use 16 or 20-bits. This does not affect microphone, microphone2, PCM In, PCM2 In, or S/PDIF DMA. When greater than 16-bits audio is used, the data structures are aligned as 32-bits per sample, with the <u>upper</u> order bits representing the data, and the <u>lower</u> order bits as don't care.</p> <p>00 = 16 bit audio (default)</p> <p>01 = 20 bit audio</p> <p>10 = 24-bit audio (not supported. If set, indeterminate behavior will result.</p> <p>11 = Reserved. If set, indeterminate behavior will result.</p>

**Note:** Software must ensure that the PCM out DMA engine is stop and a new descriptor initialized before changing the value of PCM Out mode. These bits **must not** be modified when the PCM Out engine is running.



This page is intentionally left blank.

## 6 Independent S-P/DIF Output Capability

The ICH5 AC'97 controller provides an independent DMA engine for S-P/DIF output that operates independently of the six channels PCM Out stream. This allows the S-P/DIF data stream to be independent of the PCM stream, allowing usage models such as playing a DVD movie with output to S-P/DIF while at the same time using PCM In and Out in a telephony application.

The S-P/DIF DMA engine is initialized and is programmed in the same manner as the other DMA engines available, as described in Section 3.2.

Data from the S-P/DIF DMA engine may be output on several different pairs of slots, depending on the codec configuration. The SSM bits in the Global Control register control on which slots the S/P-DIF data is transmitted, as defined below. The default value (00) for this register is a reserved value, and so these bits **must** be appropriately programmed before the DMA engine is used. These bits are reset on controller reset, and are not affected by the reset of the S-P/DIF DMA engine.

**Table 25. Global Control Register S-P/DIF Slot Map Bits**

Bit	Type	Reset	Description										
31:30	RW	00	<p><b>S/PDIF Slot Map (SSM):</b> If the run/pause bus master bit (bit 0 of offset 2Bh) is set, then the value in these bits indicate which slots S/PDIF data is transmitted on. Software must ensure that the programming here does not conflict with the PCM channels being used. If there is a conflict, unpredictable behavior will result – the hardware will not check.</p> <table border="1"> <thead> <tr> <th>Bits</th> <th>Output Slots for S/PDIF Data</th> </tr> </thead> <tbody> <tr> <td>00</td> <td><i>Reserved</i></td> </tr> <tr> <td>01</td> <td>7 &amp; 8</td> </tr> <tr> <td>10</td> <td>6 &amp; 9</td> </tr> <tr> <td>11</td> <td>10 &amp; 11</td> </tr> </tbody> </table>	Bits	Output Slots for S/PDIF Data	00	<i>Reserved</i>	01	7 & 8	10	6 & 9	11	10 & 11
				Bits	Output Slots for S/PDIF Data								
				00	<i>Reserved</i>								
				01	7 & 8								
				10	6 & 9								
11	10 & 11												



This page is intentionally left blank.

## 7 **Support for Double Rate Audio**

---

The ICH5 AC'97 controller has the capability of supporting a stereo 96 kHz stream using the AC'97 Double Rate Audio (DRA) support. This capability is enabled by programming the controller to use four-channel mode, which will place data on slots 3, 4, 7, and 8. A codec that is capable of treating the stream as PCM Left, Right, Left+1, and Right+1 data will interpret this as 96 kHz stream, providing higher quality audio.

Note that the current *AC '97 Component Specification, Revision 2.3* provides support for Double Rate on slots 3, 4, 10, and 11, a mode that is not supported by the ICH5 controller. Codecs will need to additionally accept data on slots 3, 4, 7, and 8 to utilize DRA with the ICH5.



This page is intentionally left blank.



# 8 Independent Input Channels Capability

ICH5 AC '97 controller provides capability for two DMA channels dedicated to independent PCM and Microphone audio streams. These allow improved features that enable applications such as audio mobile docking and microphone arrays. Before the DMA transfer can occur software must determine the proper codec topology in the AC-link in order to program proper volume values and other relevant properties.

## 8.1 Link Topology Determination

While the SDATA\_Out lines are shared by all AC '97 Component Specification, Revision 2.3-compliant codecs, the input DMA engines must be properly steered to specific SDATA\_IN[0:2] lines on the link. Software must determine the specific codec ID assignment to the SDATA\_IN[0:2] lines to properly adjust codec properties for operation. Software must fill a table similar to the following:

**Table 26. Topology Descriptor**

Input Channels	SDATA_IN[0:2]	Codec ID[00:10]
PCM IN & MIC	?	?
PCM IN 2 & MIC 2	?	?

Software uses a recurrent algorithm using the SDATA\_IN Map Register to determine the values for the table above.

*MBBAR + 80h: SDATA\_IN Map Register.*

**Table 27. SDATA\_IN Map**

Bit	Description
7:6	PCM In 2, Microphone In 2 Data In Line (D21L): When the SE bit is set, these bits indicates which SDATA_IN line should be used by the hardware for decoding the input slots for PCM In 2 and Microphone In 2. When the SE bit is cleared, the value of these bits are irrelevant, and PCM In 2 and Mic In 2 DMA engines are not available. 00 SDATA_IN0 01 SDATA_IN1 10 SDATA_IN2 11 Reserved
5:4	PCM In 1, Microphone In 1 Data In Line (D11L): When the SE bit is set, these bits indicates which SDATA_IN line should be used by the hardware for decoding the input slots for PCM In 1 and Microphone In 1. When the SE bit is cleared, the value of these bits are irrelevant, and the PCM In 1 and Mic In 1 engines use the OR'd SDATA_IN lines. 00 SDATA_IN0 01 SDATA_IN1 10 SDATA_IN2

Bit	Description
	11 Reserved
3	Steer Enable (SE): When set, the SDATA_IN lines are treated separately and not OR'd together before being sent to the DMA engines. When cleared, the SDATA_IN lines are OR'd together, and the "Microphone In 2" and "PCM In 2" DMA engines are not available.
2	Reserved
1:0	Last Codec Read Data Input (LDI): When a codec register is read, this indicates which SDATA_IN the read data returned on. Software can use this to determine how the codecs are mapped. The values are: 00 SDATA_IN0 01 SDATA_IN1 10 SDATA_IN2 11 Reserved

Software must follow the following steps to determine the codec topology:

1. Determine codec present by reading the codec ready bits GLOB\_STA Global Status Register. *MBBAR + 30h: SDATA\_IN Map Register.*

**Table 28. Codec Ready Bits**

Bit	Description
28	Tertiary Codec Ready (TRI) – RO. Provides the state of codec ready bit on SDATA_IN[2]
9	Secondary Codec Ready (TRI) – RO. Provides the state of codec ready bit on SDATA_IN[1]
8	Primary Codec Ready (PRI) – RO. Provides the state of codec ready bit on SDATA_IN[0]

2. Once codec present is determined, software will determine the ID of the codec attached to each SDATA\_IN line in used by reading any codec register at codec ID 00, 01 or 10. As indicated in [Table 29](#) below and determine the returning SDATA\_IN line by reading bits 1:0 in SDATA\_IN Map registers as shown in [Table 27](#). SDATA\_IN Map, above.

**Table 29. MMBAR: Mixer Base Address Register**

Codec ID 00 (offset)	Codec ID 00 (Offset)	Codec ID 00 (Offset)
00h to 7Fh	80h to FFh	100-7Fh

3. Base on the codec assignment and the specific application software will map the specific DMA engines to the appropriate SDATA\_IN[0:2] lines by programming [7:6] for PCM/MIC and [5:4] for PCM/MIC2 in SDATA\_IN MAP register as per [Table 27](#).
4. Finally software will enable the steering mechanism by asserting bit [3] in SDATA\_IN Map register before initiating a data transfer.

## 9 Intel® ICH5 AC '97 Modem Driver

---

The *AC '97 Component Specification* allows for a modem codec to be connected to the AC-link interface. This allows for the development of a software stack that provides modem functionality, i.e. a soft modem. Currently there is no single definition of how a soft-modem should be implemented under Microsoft operating systems as is the case for audio in a WDM environment. Soft modem vendors have developed a variety of implementations for Microsoft Windows\* 95, Windows\* 98, Windows NT\* 4.0 and Windows NT 5.0 operating systems. The design problems are not trivial for the soft-modem developer. This document does not attempt to describe solutions for each of these environments, but focuses instead on facilitating the development of the driver/hardware interface. At the time of this specification, Microsoft and Intel are engaging with the industry to define a common interface for the WDM environment.

### 9.1 Robust Host-Based Generation of a Synchronous Data Stream

This section presents a method for synchronous modem data to be reliably generated on the host processor of a computer system where the host processor is running a non real-time operating system whose maximum response latency (interrupt, thread, etc.) exceeds the period at which the host processor generates consecutive buffers of modem data. For the purposes of this discussion we will assume that the host processor periodically, in response to interrupts, generates a buffer of modem data in memory, which is then utilized or consumed in a synchronous fashion by hardware. This modem data would comprise a sequence of digital representations of the analog signal to be transmitted over a phone line in accordance with one of a variety of modem protocols, baud rates, etc., and could be transmitted to the ICH5 AC '97 DMA engines via the buffer descriptor list as described in Section 3.2.

We will also assume, for the sake of simplicity, that the data are double buffered, so that failure to generate new data before the next period will result in stream underflow from the hardware's viewpoint, but other scenarios including multiply buffered designs as well as non-periodic processing models can be accommodated. The algorithm works by providing good data followed by spurious data, which is chosen or computed so as to be adequate to maintain connection with the other modem by, for example, transitioning seamlessly with respect to the phase of the carrier frequency and the baud rate, thereby avoiding a retrain. This enables the datapumps of the two modems to maintain synchronization in the face of infrequent hold-offs from processing experienced by the datapump of the host-based transmitting modem. The spurious data will, of course, cause a packet retransmission or other action by the controller, but to the receiving modem the incoming data signal will be indistinguishable from one corrupted by line conditions.



The first invocation of the host based modem task provides an initial buffer and one or more buffers of spurious data (henceforth, spurious buffers). The task chooses or computes each of the spurious buffer(s) based on signal state at end of immediately preceding buffer. Note that these buffers do not have to be computed on the fly but can be precomputed and indexed into at run time. Subsequent invocations overwrite the previously provided spurious data with good data so that under normal conditions the spurious data is never used or consumed by the DMA engine. In the event that the host based modem task does not generate the next buffer in time for the DMA engine to begin consuming it the DMA engine is able to begin consuming the spurious buffer and thereby maintain seamless connection with the other modem's datapump.

### 9.1.1 Spurious Data Algorithm

The following pseudo code presents a conceptual view the algorithm. `LastState()` is a function of which returns a unique integer as a function of, for example, the carrier phase and baud position of the *last* sample in the buffer. In an actual implementation this value would be computed during the course of generating the buffer. The `SpuriousBufferList` is an array of precomputed spurious buffers.

```
while (1)
{
    compute next buffer;
    pNextBuffer = &buffer;
    pSpuriousBuffer = &(SpuriousBufferList [LastState (buffer) ] );
    wait for timer interrupt;
}
```

In this simplified scenario the device grabs the `pNextBuffer` address and stores it locally, using it to request the samples in the buffer one at a time. At the same time the device copies the `pSpuriousBuffer` into `pNextBuffer` so that when it is done with the current buffer it will get the spurious buffer unless the host software runs and overwrites `pNextBuffer` with a pointer to good data. In the next section we show how to implement the spurious data algorithm within the context of the ICH5 AC '97 buffer descriptor interface to hardware.

### 9.1.2 Intel® ICH5 AC '97 Spurious Data Implementation

The following pseudo code presents a modified version of the routine that prepares buffers and inserts them into the ICH5 AC '97 buffer descriptor list. In contrast to the version of this routine given in Section 3.2.3, in this version `tail` points to the last good (i.e., non-spurious) buffer in the list. Furthermore, because the ICH5 AC '97 DMA engine pre-fetches the next buffer descriptor we split the buffer generated by the datapump into two parts, with the second as small as practical and denote this size as `MinBufferLength` (here assumed to be 8 samples = 4 DWORDS = 500  $\mu$ s. at 16 kHz.). For simplicity we assume that only a single buffer is generated by the datapump at a time and we ignore checking for the end of the descriptor list (i.e., the addition is implicitly modulo 32).

```

while (tail <= Prefetched_Index)
{
    tail++; // Happens IFF Spurious Data was used
}
if ( ((tail <= LastValidIndex) || (tail == free))
    &&(((tail+1) <= LastValidIndex) || ((tail+1) == free)) )
{
    Descriptor.BufferPtr[tail] = &buffer;
    Descriptor.BufferLength[tail] =
        length(buffer) - MinBufferLength;
    Descriptor.BufferPtr[tail+1] =
        &buffer + length(buffer) - MinBufferLength;
    Descriptor.BufferLength[tail+1] =
        MinBufferLength;
    tail += 2;
}
else
{
    ; //error: no space for this data buffer
}
if ((tail <= LastValid index) || (tail == free))
    Descriptor.BufferPtr[tail] =
        &(SpuriousBufferList [LastState(buffer)]);
    Descriptor.BufferLength[tail] =
        SpuriousBufferLength [LastState(buffer)];
    LastValidIndex = tail;
    //Note: tail is NOT incremented, so next time we'll overwrite
    //      this descriptor, which is the whole point of this
    //      algorithm
}
else
{
    LastValidIndex = tail-1; //warning: no space for spurious
    // data buffer
}
    
```

The above implementation can be improved upon in a number of ways. First, rather than adding a single (large) spurious buffer, a number of smaller ones could be chained together. In this way, the amount of spurious data actually transmitted would be reduced while still maintaining a given level of protection against long latencies for the host-based software. Additionally, the implementation could be extended to handle multiple buffers at once, inserting several buffers in a row and only splitting the last one and then appending a spurious buffer or buffers. Finally, the descriptor list is a circular buffer and a real implementation would have to check `tail` and `tail+1` against `base_address + 31 * 8`.

## Free Manuals Download Website

<http://myh66.com>

<http://usermanuals.us>

<http://www.somanuals.com>

<http://www.4manuals.cc>

<http://www.manual-lib.com>

<http://www.404manual.com>

<http://www.luxmanual.com>

<http://aubethermostatmanual.com>

Golf course search by state

<http://golfingnear.com>

Email search by domain

<http://emailbydomain.com>

Auto manuals search

<http://auto.somanuals.com>

TV manuals search

<http://tv.somanuals.com>