



Invacare® Leo™
Scooter

User Manual

EN



This manual MUST be given to the user of the product.

BEFORE using this product, read this manual and save for future reference.

Download from www.Somanuals.com. All Manuals Search And Download.



Yes, you can.®

CONTENTS

1 GENERAL	4
Symbols	4
Limited Warranty	5
2 SAFETY	6
General Guidelines	6
Operation Information	7
EMI Information.....	14
3 PRODUCT LABELING	17
4 TECHNICAL DATA	19
Typical Product Parameters	19
5 INSPECTION	21
Safety Inspection Checklists	21
6 OPERATING THE POWERED SCOOTER	24
Control Panel.....	24
Operating the Scooter.....	27
Engaging/Disengaging the Brake Release Lever.....	29
Activating/Deactivating the Audible Signals	31
7 SEAT AND ARMS	33
Removing/Installing the Seat.....	33
Adjusting Seat Height.....	35
Adjusting 90° Seat Swivel.....	37
Adjusting the Seat Position Forward/Rearward.....	38
Adjusting the Arm Width	38
Replacing Armrest Pad	39
Adjusting Armrest Angle.....	39
Installing the Seat Positioning Strap.....	40

8	TILLER ADJUSTMENT	41
	Adjusting the Tiller Angle	41
9	WHEELS AND CASTERS	42
	Removing/Installing the Drive Wheels.....	42
	Removing/Installing the Front Wheels - Four Wheel Models.....	43
	Removing/Installing the Front Wheels - Three Wheel Models	44
10	BATTERIES	46
	Recommended Battery Type	47
	Removing/Installing the Batteries	48
	Charging the Batteries	50
11	TRANSPORTING	52
	Transporting the Scooter.....	52
12	MAINTENANCE	54
	Suggested Maintenance Procedures	54
13	TROUBLESHOOTING	55
	General Troubleshooting.....	55
	Service Indicator Error Codes.....	57

I General

I.1 Symbols

Warnings

Signal words are used in this manual and apply to hazards or unsafe practices which could result in personal injury or property damage. See the information below for definitions of the signal words.



DANGER

Danger indicates an imminently hazardous situation which, if not avoided, will result in death or serious injury.



WARNING

Warning indicates a potentially hazardous situation which, if not avoided, could result in death or serious injury.



CAUTION

Caution indicates a potentially hazardous situation which, if not avoided, may result in property damage or minor injury or both.



IMPORTANT

Indicates a hazardous situation that could result in damage to property if it is not avoided.



Gives useful tips, recommendations and information for efficient, trouble-free use.

1.2 Limited Warranty



PLEASE NOTE: THE WARRANTY BELOW HAS BEEN DRAFTED TO COMPLY WITH FEDERAL LAW APPLICABLE TO PRODUCTS MANUFACTURED AFTER JULY 4, 1975.

This warranty is extended only to the original purchaser/user of our products.

This warranty gives you specific legal rights and you may also have other legal rights which vary from state to state.

Invacare warrants all electronics and electrical components (excluding batteries), transaxle and frame to be free from defects in materials and workmanship for a period of twelve (12) months from the date of purchase from Invacare or a dealer. Invacare warrants all batteries to be free from defects in materials and workmanship for a period of six (6) months from the date of purchase from Invacare or a dealer. If within such warranty period any such product shall be proven to be defective, such product shall be repaired or replaced at Invacare's option. This warranty does not include any labor or shipping charges incurred in replacement part installation or repair of any such product. Invacare's sole obligation and your exclusive remedy under this warranty shall be limited to such repair and/or replacement.

For warranty service, please contact the dealer from whom you purchased your Invacare product. In the event you do not receive satisfactory warranty service, please write directly to Invacare at the address on the bottom of the back cover. Provide dealer's name address, date of purchase, indicate nature of the defect and, if the product is serialized, indicate the serial number. Do not return products to our factory without our prior consent.

LIMITATIONS AND EXCLUSIONS: THE FOREGOING WARRANTY SHALL NOT APPLY TO SERIAL NUMBERED PRODUCTS IF THE SERIAL NUMBER HAS BEEN REMOVED OR DEFACED, PRODUCTS SUBJECT TO NEGLIGENCE, ACCIDENT, IMPROPER OPERATION, MAINTENANCE OR STORAGE, COMMERCIAL OR INSTITUTIONAL USE, PRODUCTS MODIFIED WITHOUT INVACARE'S EXPRESS WRITTEN CONSENT INCLUDING, BUT NOT LIMITED TO, MODIFICATION THROUGH THE USE OF UNAUTHORIZED PARTS OR ATTACHMENTS; PRODUCTS DAMAGED BY REASON OF REPAIRS MADE TO ANY COMPONENT WITHOUT THE SPECIFIC CONSENT OF INVACARE, OR TO A PRODUCT DAMAGED BY CIRCUMSTANCES BEYOND INVACARE'S CONTROL, AND SUCH EVALUATION WILL BE SOLELY DETERMINED BY INVACARE. THE WARRANTY SHALL NOT APPLY TO PROBLEMS ARISING FROM NORMAL WEAR OR FAILURE TO ADHERE TO THESE INSTRUCTIONS. A CHANGE IN OPERATING NOISE, PARTICULARLY RELATIVE TO MOTORS AND GEARBOXES DOES NOT CONSTITUTE A FAILURE. ALL SUCH DEVICES WILL EXHIBIT A CHANGE IN OPERATING NOISE DUE TO AGING.

THE FOREGOING EXPRESS WARRANTY IS EXCLUSIVE AND IN LIEU OF ANY OTHER WARRANTIES WHATSOEVER, WHETHER EXPRESS OR IMPLIED, INCLUDING THE IMPLIED WARRANTIES OF MERCHANTABILITY AND FITNESS FOR A PARTICULAR PURPOSE, AND THE SOLE REMEDY FOR VIOLATIONS OF ANY WARRANTY WHATSOEVER, SHALL BE LIMITED TO REPAIR OR REPLACEMENT OF THE DEFECTIVE PRODUCT PURSUANT TO THE TERMS CONTAINED HEREIN, THE APPLICATION OF ANY IMPLIED WARRANTY WHATSOEVER SHALL NOT EXTEND BEYOND THE DURATION OF THE EXPRESS WARRANTY PROVIDED HEREIN. INVACARE SHALL NOT BE LIABLE FOR ANY CONSEQUENTIAL OR INCIDENTAL DAMAGES WHATSOEVER.

THIS WARRANTY SHALL BE EXTENDED TO COMPLY WITH STATE/PROVINCIAL LAWS AND REQUIREMENTS.

2 Safety

The Safety section contains important information for the safe operation and use of this product.

2.1 General Guidelines



WARNING

DO NOT use this product or any available optional equipment without first completely reading and understanding these instructions and any additional instructional material such as owner's manuals, service manuals or instruction sheets supplied with this product or optional equipment. If you are unable to understand the warnings, cautions or instructions, contact a healthcare professional, dealer or technical personnel before attempting to use this equipment - otherwise, injury or damage may occur.

Procedures other than those described in this manual **MUST** be performed by a qualified technician.



ACCESSORIES WARNINGS

Invacare products are specifically designed and manufactured for use in conjunction with Invacare accessories. Accessories designed by other manufacturers have not been tested by Invacare and are not recommended for use with Invacare products.

DO NOT connect any medical devices such as ventilators, life support machines, etc., to the battery. This could cause unexpected failure of the device and the powered scooter.



NOTICE

THE INFORMATION CONTAINED IN THIS DOCUMENT IS SUBJECT TO CHANGE WITHOUT NOTICE.

Check all parts for shipping damage and test before using. In case of damage, DO NOT use. Contact Invacare/Carrier for further instruction.

As a manufacturer of powered scooters, Invacare endeavors to supply a wide variety of powered scooters to meet many needs of the end user. However, final selection of the type of powered scooter to be used by an individual rests solely with the user and his/her healthcare professional capable of making such a selection.

2.2 Operation Information

Setup



WARNING

Before using the scooter, verify that the motor is plugged into the harness.

Driving



WARNING

DO NOT operate on roads, streets or highways.

Running lights are for increased user visibility ONLY and are NOT intended for use as automobile head/signal lights.

Transport



WARNING

TIE-DOWN RESTRAINTS AND SEAT RESTRAINTS

Powered scooter users should NOT be transported in vehicles of any kind while in the powered scooter. As of this date, the Department of Transportation has not approved any tie-down systems for transportation of a user while in a powered scooter, in a moving vehicle of any type.

It is Invacare's position that users of powered scooters should be transferred into appropriate seating in vehicles for transportation and use be made of the restraints made available by the auto industry. Invacare cannot and does not recommend any powered scooter transportation systems.

2 SAFETY



WARNING

STAIRWAYS AND ESCALATORS

DO NOT attempt to move an occupied powered scooter between floors using a stairway. Use an elevator to move an occupied powered scooter between floors.

If moving a powered scooter between floors by means of a stairway, the occupant **MUST** be removed and transported independently of the powered scooter. Extreme caution is advised when moving an unoccupied powered scooter up or down the stairs. Invacare recommends disassembling the scooter and transporting the components independently up or down the stairs. **ONLY** use secure, non-detachable parts on each component for hand-hold supports.

DO NOT attempt to lift the powered scooter by any removable (detachable) parts. Lifting by means of any removable (detachable) parts of a powered scooter may result in injury to the user or damage to the powered scooter.

DO NOT use an escalator to move a powered scooter between floors. Serious bodily injury may occur.

Powered scooter with batteries and seat weighs between 184 lbs. Use proper lifting techniques (lift with your legs) to avoid injury.

DO NOT attempt to lift the powered scooter by its tiller, seat or shrouds.

If scooter is exposed to extreme temperature (above 100°F or below 32°F), high humidity and/or becomes wet, prior to use, ensure handgrips DO NOT twist on scooter handles. Otherwise, damage or injury may occur.

Follow this procedure for moving the powered scooter between floors when an elevator is not available:

1. Remove the occupant from the powered scooter.
2. Disassemble the scooter. Refer to [Transporting the Scooter](#) on page 52.
3. Carefully move the powered scooter components up or down the stairway.
4. Once all the components of the scooter are transported to the desired location reassemble the scooter. Refer to [Transporting the Scooter](#) on page 52.

Repair or Service Information



WARNING

Scooters should be examined during maintenance for signs of corrosion (water exposure, incontinence, etc.). Electrical components damaged by corrosion should be replaced **IMMEDIATELY**.

Set-up of the Electronics Control Unit is to be performed only by a qualified technician. The final adjustments of the controller may affect other activities of the scooter. Damage to the equipment could occur if improperly set-up or adjusted.

DO NOT service or adjust your powered scooter while occupied, unless otherwise noted.

DO NOT overtighten hardware attaching to the frame. This could cause damage to the frame tubing.

Safety/Handling of Powered Scooters

“Safety and Handling” of the powered scooter requires the close attention of the user. This manual points out the most common procedures and techniques involved in the safe operation and maintenance. It is important to practice and master these safe techniques until you are comfortable in maneuvering the powered scooter.

Use this information only as a “basic” guide. The techniques that are discussed have been used successfully by many. Individual users often develop skills to deal with daily living activities that may differ from those described in this manual. Invacare recognizes and encourages each individual to try what works best for him/her in overcoming obstacles that they may encounter; however, all warnings and cautions given in this manual **MUST** be followed. Techniques in this manual are a starting point for the new powered scooter user with “safety” as the most important consideration for all.



WARNING

DO NOT make sharp turns in the forward or reverse direction at excessive speed. Failure to observe the warning can cause the scooter to tip over and may result in injury to user and/or damage to the product.

ALWAYS wear your seat positioning strap. Inasmuch as the seat positioning strap is an option on this scooter (you may order with or without the seat positioning strap), Invacare strongly recommends ordering the seat positioning strap as an additional safeguard for the scooter user. The seat positioning strap is a positioning strap only. It is not designed for use as a safety device withstanding high stress loads such as auto or aircraft safety belts. If signs of wear appear, strap must be replaced immediately.

DO NOT attempt to reach objects if you have to move forward in the seat or pick them up from the floor by reaching between your knees.

2 SAFETY

To assure stability and proper operation of your powered scooter, you **MUST**, at all times, maintain proper balance. Your powered scooter has been designed to remain upright and stable during normal daily activities.

Many activities require the scooter owner to reach, bend and transfer in and out of the powered scooter. These movements cause a change to the normal balance, the center of gravity, and the weight distribution of the powered scooter. To determine and establish your particular safety limits, practice bending, reaching and transferring activities in several combinations in the presence of a qualified healthcare professional before attempting active use of the scooter. Proper positioning is essential for your safety.



WARNING

DO NOT stand on the frame of the powered scooter while driving.

DO NOT stand on the shroud(s) of the powered scooter.

DO NOT lean over the top of the back upholstery to reach objects behind you, as this may cause the powered scooter to tip over.

DO NOT shift your weight or sitting position toward the direction you are reaching as the powered scooter may tip over.

Determine and establish your particular safety limits by practicing bending, reaching and transferring activities in the presence of a qualified healthcare professional before attempting active use of the powered scooter.

For individuals with balance problems, DO NOT attempt to transfer into or out of the powered scooter without assistance. Practice transferring activities with an assistant in the presence of a qualified healthcare professional.

Performance adjustments should only be made by professionals of the healthcare field or persons fully conversant with this process and the driver's capabilities. Incorrect settings could cause injury to the driver, bystanders and damage to the scooter and to surrounding property.

DO NOT operate the powered scooter until you have checked that the surroundings are clear and that the area is safe for travel.

DO NOT operate on roads, streets or highways.

DO NOT attempt to move up or down an incline with water, ice or oil film.

Avoid operating the scooter in dark or poorly lit areas.

DO NOT climb and/or go up or down ramps or traverse slopes greater than 8°.



WARNING

When negotiating ramps, if the throttle control lever is released while in the forward motion, the powered scooter will roll back approximately one foot before the brake engages. If the throttle control lever is released while in the reverse motion, the powered scooter will roll back approximately three feet before the brake engages.

DO NOT attempt to drive over curbs or obstacles. Doing so may cause your powered scooter to turn over and cause bodily harm and/or damage to the scooter.

Before attempting to sit in or exit the powered scooter, remove the key from the ignition. This will ensure that the power is off and the powered scooter will not drive.

DO NOT remove the key or shut off while the powered scooter is in motion.

DO NOT operate the powered scooter without the rear shroud installed, to avoid injury and/or damage to scooter.

Ensure that the seat is properly locked before use. Otherwise the user may fall from the scooter resulting in bodily harm.

Attempting unsafe transfers may cause the user to fall, resulting in serious injury.

Ensure that the seat is locked in the forward position before and during the operation of the scooter. Otherwise, injury to the user and/or damage to the scooter may result.

Ensure that the tiller is properly adjusted before driving the scooter.

After making any tiller angle adjustment and before use, the tiller must be securely locked into position. Otherwise the user may fall from the scooter resulting in bodily harm and/or damage to the scooter. Gently push/pull the tiller to ensure that the tiller is securely engaged.

ALWAYS keep hands and fingers clear of moving parts to avoid injury.

ALWAYS check hand grips for looseness before using the powered scooter. If loose and/or worn, replace immediately.

Never leave an unoccupied scooter on an incline.

ALWAYS use anti-tippers. When outdoors on wet, soft ground or on gravel surfaces, anti-tippers may not provide the same level of protection against tip over. Extra caution **MUST** be observed when traversing such surfaces.

2 SAFETY

Storage



WARNING

Scooters that are used by incontinent users and/or are frequently exposed to water may require replacement of electrical components more frequently.

RAIN TEST

Invacare has tested its powered scooters in accordance with ISO 7176 "Rain Test". This provides the end user or his/her attendant sufficient time to remove his/her powered scooter from a rain storm and retain powered scooter operation.

DO NOT leave the powered scooter in a rain storm of any kind.

DO NOT use the powered scooter in a shower.

DO NOT leave the powered scooter in a damp area for any length of time.

Direct exposure to rain or dampness will cause the scooter to malfunction electrically and mechanically; may cause the powered scooter to prematurely rust.

Check to ensure that all electrical connections are secure at all times.

Remove the key from the ignition while the powered scooter is not in use so as to avoid injury and/or damage to the scooter and surrounding areas.

Avoid storing or using the scooter near open flame or combustible products. Serious injury or damage to property may result.

Electrical and Grounding



WARNING

Check to ensure that all electrical connections are secure at all times.

GROUNDING INSTRUCTIONS

DO NOT, under any circumstances, cut or remove the round grounding prong from any plug used with or for Invacare products. Some devices are equipped with three-prong (grounding) plugs for protection against possible shock hazards. Where a two-prong wall receptacle is encountered, it is the personal responsibility and obligation of the customer to contact a qualified electrician and have the two-prong receptacle replaced with a properly grounded three-prong wall receptacle in accordance with the National Electrical Code. If you must use an extension cord, use **ONLY** a three-wire extension cord having the same or higher electrical rating as the device being connected. In addition, Invacare has placed **RED/ORANGE** warning tags on some equipment. **DO NOT** remove these tags.

Battery



WARNING

The warranty and performance specifications contained in this manual are based on the use of AGM batteries. Invacare strongly recommends their use as the power source for this unit.

Carefully read battery/battery charger information prior to installing, servicing or operating your powered scooter.

Weight Training



WARNING

Invacare **DOES NOT** recommend the use of its powered scooters as a weight training apparatus. Invacare powered scooters have **NOT** been designed or tested as a seat for any kind of weight training. If occupant uses said powered scooter as a weight training apparatus, Invacare shall **NOT** be liable for bodily injury and the warranty is void.

2 SAFETY

Weight Limitation



WARNING

The weight limitation is 350 lbs.

Disposal



WARNING

This product has been supplied from an environmentally aware manufacturer that complies with the Waste Electrical and Electronic Equipment (WEEE) Directive 2002/96/CE.

This product may contain substances that could be harmful to the environment if disposed of in places (landfills) that are not appropriate according to legislation.

Please be environmentally responsible and recycle this product through your recycling facility at its end of life.

2.1 EMI Information



CAUTION

IT IS VERY IMPORTANT THAT YOU READ THIS INFORMATION REGARDING THE POSSIBLE EFFECTS OF ELECTROMAGNETIC INTERFERENCE ON YOUR POWERED WHEELCHAIR.

Electromagnetic Interference (EMI) From Radio Wave Sources

Powered wheelchairs and motorized scooters (in this text, both will be referred to as powered wheelchairs) may be susceptible to electromagnetic interference (EMI), which is interfering electromagnetic energy (EM) emitted from sources such as radio stations, TV stations, amateur radio (HAM) transmitters, two way radios, and cellular phones. The interference (from radio wave sources) can cause the powered wheelchair to release its brakes, move by itself, or move in unintended directions. It can also permanently damage the powered wheelchair's control system. The intensity of the interfering EM energy can be measured in volts per meter (V/m). Each powered wheelchair can resist EMI up to a certain intensity. This is called its "immunity level." The higher the immunity level, the greater the protection. At this time, current technology is capable of achieving at least a 20 V/m immunity level, which would provide useful protection from the more common sources of radiated EMI.

There are a number of sources of relatively intense electromagnetic fields in the everyday environment. Some of these sources are obvious and easy to avoid. Others are not apparent and exposure is unavoidable. However, we believe that by following the warnings listed below, your risk to EMI will be minimized.

The sources of radiated EMI can be broadly classified into three types:

1. Hand-held Portable transceivers (transmitters-receivers with the antenna mounted directly on the transmitting unit. Examples include: citizens band (CB) radios, "walkie talkie", security, fire and police transceivers, cellular telephones, and other personal communication devices).



Some cellular telephones and similar devices transmit signals while they are ON, even when not being used.

2. Medium-range mobile transceivers, such as those used in police cars, fire trucks, ambulances and taxis. These usually have the antenna mounted on the outside of the vehicle; and
3. Long-range transmitters and transceivers, such as commercial broadcast transmitters (radio and TV broadcast antenna towers) and amateur (HAM) radios.



Other types of hand-held devices, such as cordless phones, laptop computers, AM/FM radios, TV sets, CD players, cassette players, and small appliances, such as electric shavers and hair dryers, so far as we know, are not likely to cause EMI problems to your powered wheelchair.

Powered Wheelchair Electromagnetic Interference (EMI)

Because EM energy rapidly becomes more intense as one moves closer to the transmitting antenna (source), the EM fields from hand-held radio wave sources (transceivers) are of special concern. It is possible to unintentionally bring high levels of EM energy very close to the powered wheelchair's control system while using these devices. This can affect powered wheelchair movement and braking. Therefore, the warnings listed below are recommended to prevent possible interference with the control system of the powered wheelchair.

Electromagnetic interference (EMI) from sources such as radio and TV stations, amateur radio (HAM) transmitters, two-way radios, and cellular phones can affect powered wheelchairs and motorized scooters.

FOLLOWING THE WARNINGS LISTED BELOW SHOULD REDUCE THE CHANCE OF UNINTENDED BRAKE RELEASE OR POWERED WHEELCHAIR MOVEMENT WHICH COULD RESULT IN SERIOUS INJURY.



WARNING

- 1) DO NOT operate hand-held transceivers (transmitters receivers), such as citizens band (CB) radios, or turn ON personal communication devices, such as cellular phones, while the powered wheelchair is turned ON;
- 2) Be aware of nearby transmitters, such as radio or TV stations, and try to avoid coming close to them;
- 3) If unintended movement or brake release occurs, turn the powered wheelchair OFF as soon as it is safe;
- 4) Be aware that adding accessories or components, or modifying the powered wheelchair, may make it more susceptible to EMI (NOTE: There is no easy way to evaluate their effect on the overall immunity of the powered wheelchair); and
- 5) Report all incidents of unintended movement or brake release to the powered wheelchair manufacturer, and note whether there is a source of EMI nearby.

Important Information

- 1) 20 volts per meter (V/m) is a generally achievable and useful immunity level against EMI (as of May 1994) (the higher the level, the greater the protection);
- 2) This device has been tested to a radiated immunity level of 20 volts per meter.
- 3) The immunity level of the product is unknown.

Modification of any kind to the electronics of this scooter as manufactured by Invacare may adversely affect the EMI immunity levels.

3 Product Labeling



Four wheel model shown. The labels are in the same locations for the three wheel model.

WEIGHT CAPACITY
350 LBS. (159 kgs.)
 REFER TO OWNER'S MANUAL
 P/N 1111017



WARNING
 Ensure that seat lock lever is locked. Refer to Owner's Manual.
 P/N 1125058



Serial
 Number
 Label

WARNING
 DO NOT operate the scooter unless the tiller is in the locked position.
 DO NOT lean against or pull forward on the tiller while mounting or dismounting the scooter. Otherwise, injury may occur.
 DO NOT lift scooter up by the front or rear shroud. Otherwise injury or damage to the scooter may occur.
 1116373 Rev A

3 PRODUCT LABELING

⚠ WARNING DO NOT REMOVE THIS LABEL.

The **POSITIVE (+) RED** battery cable **MUST** connect to the **POSITIVE (+)** battery terminal. The **NEGATIVE (-) BLACK** battery cable **MUST** connect to the **NEGATIVE (-)** battery terminal. **DO NOT** allow battery cables to contact the opposite battery terminal. Replace cables **IMMEDIATELY** if cable insulation becomes damaged. Failure to observe these warnings may result in an electrical short with serious personal injury and/or damage to the electrical system. See Owner's Manual. P/N 1154310 REV A

The diagram illustrates two wiring configurations for a 12V battery system connected to a Power Module. In the first configuration, a red cable connects the positive terminal to the positive terminal of the Power Module, and another red cable connects the negative terminal to the negative terminal. A 70A fuse is placed on the positive line. In the second configuration, a red cable connects the positive terminal to the positive terminal, and a black cable connects the negative terminal to the negative terminal. A 70A fuse is also placed on the positive line.

⚠ WARNING

Lights are for increased visibility of user and are **NOT** intended for use as automobile lights. **DO NOT** operate this product on roads, streets or highways - otherwise, serious injury or damage may occur.

1171793 Rev A

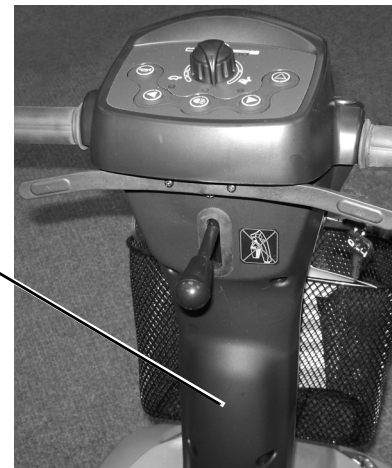

The battery wiring label is located on the underside of the top shroud.

4 Technical Data

4.1 Typical Product Parameters

Overall Dimensions

	3 WHEEL	4 WHEEL
Overall Length:	47.2 in	
Drive Unit Width:	23.2 in	
Overall Width:	23 to 29 in (armrest adjustment range)	
Overall Height:	39 in	

Seat Dimensions

	3 WHEEL	4 WHEEL
Width:	19 in	
Depth:	16 in	
Seat Height:	16.5 to 19.5 in	

Arm Dimensions

	3 WHEEL	4 WHEEL
Armrest Height:	8 in	

4 TECHNICAL DATA

Driving

	3 WHEEL	4 WHEEL
Speed:	5 mph	
Maximum Incline Capability:	6° Grade	8° Grade
Turning Radius:	47.2 in	52 in

Weight

	3 WHEEL	4 WHEEL
Weight of Product:	173.7 lbs	184 lbs
Maximum Weight Limitation:	350 lbs	



All dimensions are $\pm .50$ inches unless otherwise indicated.

Weight limitation is total weight (user weight plus any additional items that the user may require [back pack, etc.]).

Example: If weight limitation of the scooter is 350 lbs and additional items equal 25 lbs, subtract 25 lbs from 350 lbs this means the maximum weight limitation of the user is 325 lbs.

5 Inspection

5.1 Safety Inspection Checklists



Every six months take your powered scooter to a qualified technician for a thorough inspection and servicing. Regular cleaning will reveal loose or worn parts and enhance the smooth operation of your powered scooter. To operate properly and safely, your powered scooter must be cared for just like any other vehicle. Routine maintenance will extend the life and efficiency of your powered scooter.



WARNING

Before performing any maintenance, adjustment or service, turn power Off and remove key from ignition.

CAUTION

As with any vehicle, the wheels and tires should be checked periodically for cracks and wear, and should be replaced.

Initial adjustments should be made to suit your personal body structure needs and preference. Thereafter follow these maintenance procedures:

5 INSPECTION

Inspect/Adjust Initially

- Ensure powered scooter drives straight (no excessive drag or pull to one side).
- Check frame for damage and corrosion.
- Ensure that the brake release lever is easy to engage/disengage.
- Ensure that tiller adjustment mechanism engages and disengages properly and securely.
- Ensure that the scooter stops completely when throttle is released (i.e., does not continue to roll as if the throttle is activated).
- Clean upholstery and armrests.
- Ensure armrest pad sits flush against arm tube.
- Inspect the seat upholstery for rips and tears.
- Inspect seat swivel for release and engagement (seat locks into the determined swivel positions).
- Inspect for excessive side movement or binding when the drive wheels are raised or turned.
- Inspect front wheel/fork assembly for proper tension by spinning the wheel. The front wheel should come to a gradual stop.
- Check the front fork for damage or corrosion.
- Tighten locknut if the front wheel wobbles noticeably or loosen locknut if the wheel binds to a stop.
- Ensure that wheel bearings are clean and free of moisture.
- Ensure that the bolts and fasteners on the caster assemblies are tight.
- Inspect tires for flat spots and wear.
- Clean molded body shrouds.
- Check that all labels are present and legible.

Inspect/Adjust Weekly

- Ensure that tiller adjustment mechanism engages and disengages properly and securely.
- Ensure that the scooter stops completely when throttle is released (i.e., does not continue to roll as if the throttle is activated).
- Inspect tires for flat spots and wear.

Inspect/Adjust Monthly

- Check brake for binding or interference with travel.
- Inspect front wheel/fork assembly for proper tension by spinning the wheel. The front wheel should come to a gradual stop.
- Tighten locknut if the front wheel wobbles noticeably or loosen locknut if the wheel binds to a stop.
- Inspect seat swivel for release and engagement (seat locks into the determined swivel positions).
- Inspect the seat positioning strap for signs of wear. Replace if worn or damaged. Ensure buckle latches. Verify that the hardware that attaches the seat positioning strap to the frame is secure and undamaged. Replace if necessary.
- Ensure that the bolts and fasteners on the caster assemblies are tight.

Inspect/Adjust Periodically

- Ensure that the powered scooter drives straight (no excessive drag or pull to one side).
- Check frame for damage and corrosion.
- Ensure that the brake release lever is easy to engage/disengage.
- Inspect for no excessive side movement or binding when the drive wheels are raised or turned.
- Check front fork for damage or corrosion.
- Ensure wheel bearings are clean and free of moisture.
- Clean upholstery and armrests.
- Inspect the seat upholstery for rips and tears.
- Ensure armrest pad sits flush against arm tube.
- Check that all labels are present and legible.
- Inspect electrical components for signs of corrosion. Replace if corroded or damaged.

6 Operating the Powered Scooter

6.1 Control Panel



For this procedure, refer to FIGURE 6.1 on page 26.

Battery Charge Display

The battery charge display is located at the top center of the control panel. When the scooter is turned on, the LEDs on the battery charge display light to indicate the amount of battery charge. The amount of battery charge is indicated by the number of LEDs that are lit. If the charge is full, all LEDs are lit. As the battery charge decreases, the LEDs turn Off. When only RED and YELLOW LEDs are lit, the batteries are draining and should be charged soon. When only RED LEDs are lit, the scooter is running on reserve battery power. Charge the batteries immediately. The scooter has an overcharge protection feature. When the scooter is running on reserve power, the scooter may turn Off automatically. If the scooter is not driven for a while, the batteries will recuperate and allow a short amount of driving time. After this, the RED LEDs will blink and the scooter will beep 3 times. If the LEDs do not light when the scooter is turned on, the batteries should be charged.



CAUTION

Keep batteries charged to avoid battery damage. Driving the scooter on reserve battery power leads to battery damage and should be avoided if possible.

LED COLOR	LED ACTION/SOUND	BATTERY CHARGE LEVEL	ACTION REQUIRED
ALL - GREEN, YELLOW and RED	Lit	Full Charge	None
RED and YELLOW	Lit	Reduced Charge	Charge batteries after use.
RED	Lit	Low Charge	Charge batteries as soon as possible.
RED	Blinking and system beeps 3 times	Reserve Battery Power	Charge batteries immediately.
ALL - GREEN, YELLOW and RED	Dark (not lit)	None	Charge batteries immediately.

Status Display

The status display LED is located on the top of the control panel. The status display indicates if the scooter is On or Off and also flashes to indicate error codes. Refer to [Service Indicator Error Codes](#) on page 57.

Speed Control Knob

The speed control knob is located in the center of the control panel. The Turtle icon represents the slowest speed and the Rabbit icon represents the fastest speed.

Horn Button

The horn button is located on the left side of the control panel.

Warning Blinker Button

The warning blinker button flashes the YELLOW indicator lights (front and rear, left and right) when pressed.

Lighting



WARNING

Running lights are for increased user visibility **ONLY** and are **NOT** intended for use as automobile head/signal lights. **DO NOT** operate vehicle on roads, streets or highways - otherwise, serious injury or damage may occur.



The running lights offered on this product are an option intended to increase the visibility of the vehicle and user. Running lights are **NOT** intended to be used as automobile head/signal lights.

Inasmuch as this product may be equipped with running lights, this product is **NOT** intended for use on roads, streets or highways.

The lighting button is located on the bottom of the control panel. Pressing this button will illuminate the **WHITE** front running lights and **RED** rear running lights of the scooter.

Right and Left Direction Indicator Buttons

The right and left direction indicator buttons are located on lower left and right sides of the control panel. Press these to activate and deactivate the right and left direction indicators.



The direction indicators will automatically switch off after 30 seconds.

6 OPERATING THE POWERED SCOOTER

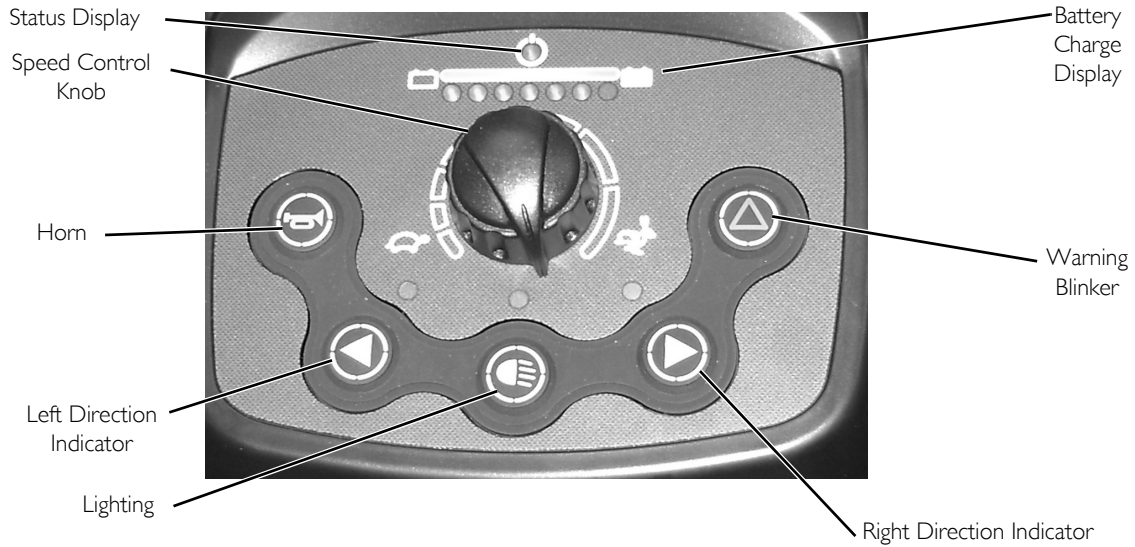

FIGURE 6.1 Control Panel

6.2 Operating the Scooter



WARNING

After any adjustments, repair or service and before use, make sure that all attaching hardware is tightened securely - otherwise injury or damage may result.

DO NOT make sharp turns in the forward or reverse direction at excessive speed. Failure to observe the warning can cause the scooter to tip over and may result in injury to user and/ or damage to the product.

To determine and establish your particular safety limits, practice bending, reaching and transferring activities in several combinations in the presence of a qualified healthcare professional before attempting active use of the powered scooter.

Ensure seat is properly locked before attempting transfer into or out of the powered scooter. Attempting unsafe transfers may cause a fall from the powered scooter resulting in bodily injury.

For individuals with balance problems, practice transferring activities with an assistant in the presence of a qualified healthcare professional. DO NOT attempt to transfer into or out of the powered scooter without assistance.

1. Before operating the powered scooter, review [Control Panel](#) on page 24.
2. Install the batteries. Refer to [Removing/Installing the Batteries](#) on page 48.
3. Charge the batteries. Refer to [Charging the Batteries](#) on page 50.
4. Transfer to the seat:
 - Flip up the armrest to make entering easier.
 - Rotate the seat to the direction of transfer. Refer to [Adjusting 90° Seat Swivel](#) on page 37.
5. Once you have transferred into the seat, rotate seat to the forward position and flip arms down.
6. Adjust the tiller to a comfortable angle. Refer to [Adjusting the Tiller Angle](#) on page 41.
7. Adjust speed control knob to the appropriate setting.



For driving indoors or on uneven terrain, a slower speed is recommended. For soft terrain or steep inclines (no greater than 8°), a faster speed may be necessary.

6 OPERATING THE POWERED SCOOTER

8. Insert the key into the ignition and turn it to the On position.



The key is on the right side just below the control panel.

The control panel illuminates when the key is turned to the On position.



WARNING

ALWAYS depress the throttle control lever gradually. This will ensure smooth safe starts.

When negotiating ramps, if the throttle control lever is released while in forward motion, the powered scooter will roll back approximately one foot before brake engages. If the throttle control lever is released while in reverse motion the powered scooter will roll back approximately three feet before brake engages.



Throttle control levers operate such that moving one will also move the opposite side throttle control lever.

The throttle control lever is located below the control panel.

9. To operate the scooter, depress the throttle control lever in the following manner:
- To Move Forward - Push the right side throttle control lever (away from the user) or pull the left side throttle control lever towards the user).
 - To Move in Reverse - Push the left side throttle control lever (away from the user) or pull the right side throttle control lever (towards the user).
 - To Stop - Release the throttle control lever and the powered scooter will quickly slow down and the brake will engage.

The powered scooter is equipped with a “proportional” control meaning that the farther you depress the throttle control lever, the faster the powered scooter travels. With a proportional control, you can drive as slowly in the high speed setting as you can in the low speed setting. Your top speed, however, is limited by the setting of the speed-control knob. For safety reasons, reverse speed is limited to approximately 50% of forward speed.

When first learning to drive, adjust speed control knob for a slow speed and try to drive the powered scooter as slowly as possible by depressing the throttle control lever only slightly. This exercise will help you learn to utilize the full potential of the proportional control and allow you to start and stop smoothly.

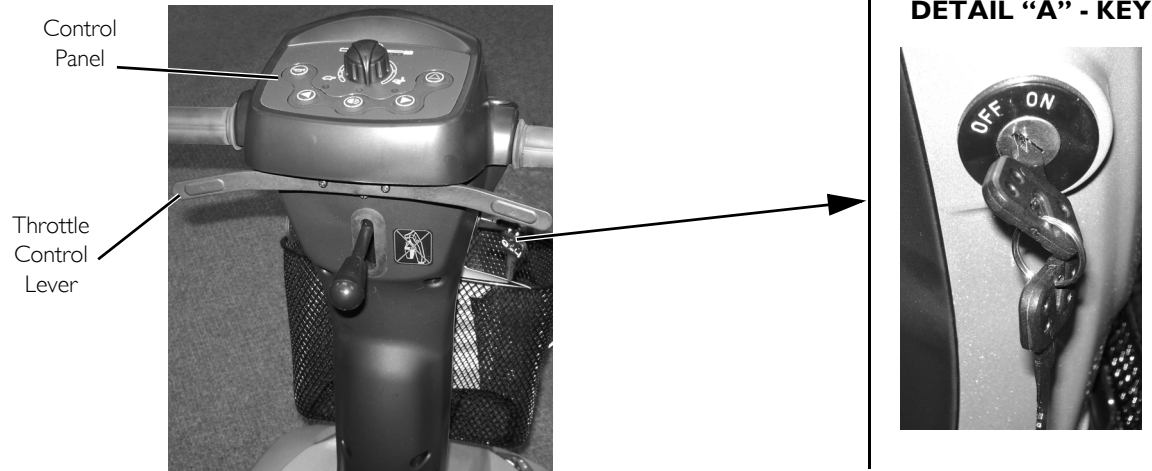

FIGURE 6.1 Operating the Scooter

6.3 Engaging/Disengaging the Brake Release Lever



WARNING

Ensure that the brake-release lever is in the engaged position before driving. There should be an audible “click” when stopping and starting the scooter.



For this procedure, refer to FIGURE 6.2 on page 30.

The brake release lever manually engages and disengages the brake. The brake release lever is located under the seat on the right side. The brake must be engaged in normal driving conditions. Activation of the throttle control lever automatically releases the brake so that the powered scooter can drive. Releasing the throttle control lever automatically engages the brake so as to prevent the powered scooter from rolling on its own.

6 OPERATING THE POWERED SCOOTER

When the brake release lever is disengaged and the key is removed, the powered scooter can be pushed. The powered scooter cannot be driven with the brake in the disengaged position.

1. To engage the brake release lever (Drive) - Pull back the brake release lever.
2. To disengage the brake release lever (Push) - Push forward the brake release lever.

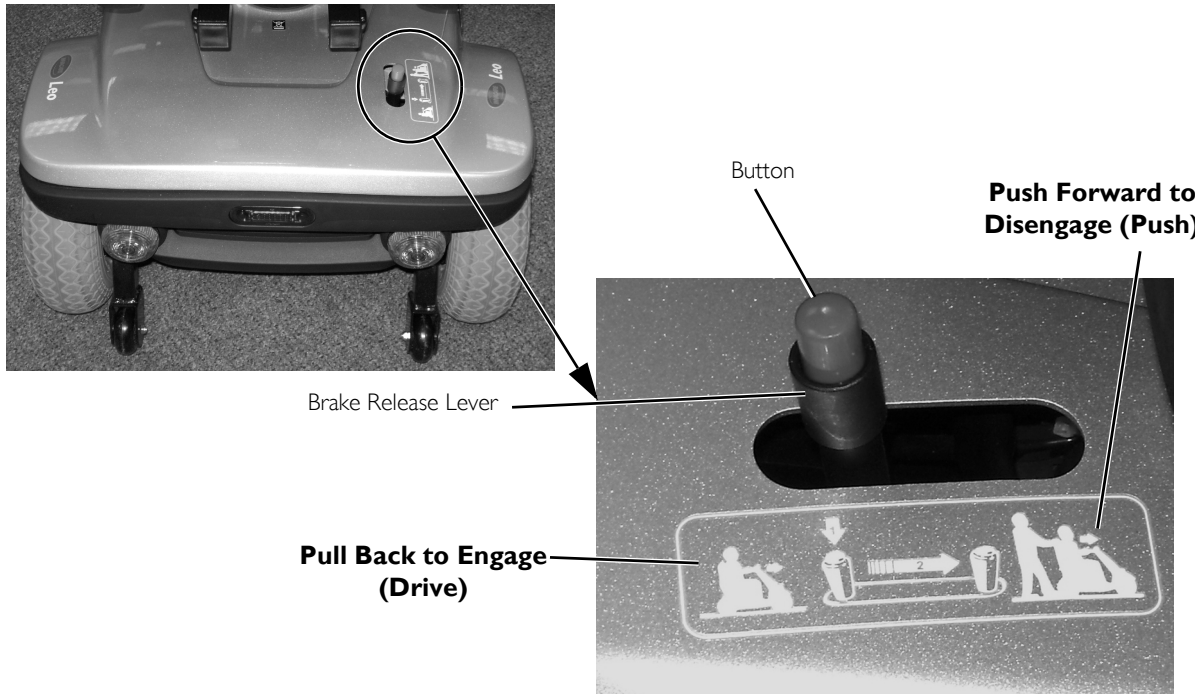

FIGURE 6.2 Engaging/Disengaging the Brake Release Lever

Activating/Deactivating the Audible Signals



For this procedure, refer to FIGURE 6.3.

The scooter system emits an audible signal in the following situations:

- Low Battery Capacity
- Direction Indicators in Use
- Hazard Lamps in Use

The audible signals can be activated or deactivated by pressing the buttons on the control panel in a particular combination keystrokes.

1. Turn the key to the Off position.
2. Press and hold the buttons on the control panel in the keystroke combination shown in the table in FIGURE 6.3.
3. Turn the key to the On position.
4. Wait two seconds until the appropriate blink code is displayed on the battery charge display, then release the buttons.



DO NOT hold the buttons for more than 5 seconds.

If LED 7 blinks five times the audible signal has been successfully activated.

The scooter will return to normal operating status automatically.

6 OPERATING THE POWERED SCOOTER

AUDIBLE SIGNAL	KEYSTROKE COMBINATION	LIT LEDS	CONDITION
Low Battery Capacity	Lighting + Left Direction Indicator	1	Deactivated
		1 + 2	Activated
Direction Indicators	Lighting + Right Direction Indicator	3	Deactivated
		3 + 4	Activated
Hazard Lamps	Lighting + Warning Blinker	5	Deactivated
		5 + 6	Activated

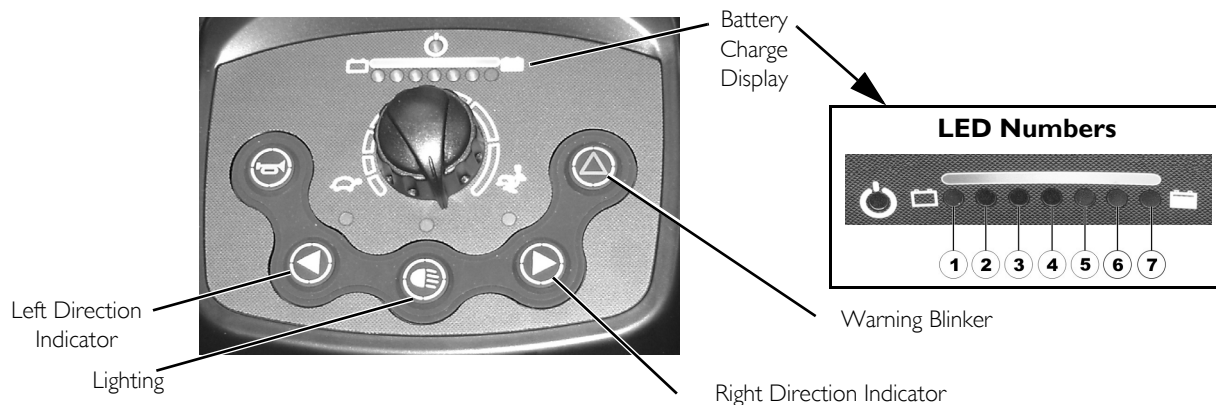

FIGURE 6.3 Activating/Deactivating the Audible Signals

7 Seat and Arms



WARNING

After any adjustments, repair or service and before use, make sure that all attaching hardware is tightened securely - otherwise injury or damage may result.

Before performing any maintenance, adjustment or service, turn power off and remove key from ignition.



Refer to [Product Labeling](#) on page 17 for pinch point location.

7.1 Removing/Installing the Seat



WARNING

Before use, ensure that the seat is in the locked position. The seat lever **MUST** be pulled up all the way to allow the seat to drop into the locked position. Otherwise, a fall from the scooter could occur causing bodily injury and/or damage to the scooter.



For this procedure, refer to [FIGURE 7.1](#) on page 34.

Removing

1. Pull up the seat lock lever.
2. Turn the seat to one side.
3. Hold the seat assembly firmly by the backrest and the front edge of the seat.
4. Lift the seat assembly up and away from the seat post.

Installing

1. Pull up the seat lock lever.
2. Lower the seat assembly onto the seat post.
3. Turn the seat so it faces forward and locks into position.
4. Lift up on seat assembly to ensure the seat is secure.

7 SEAT AND ARMS

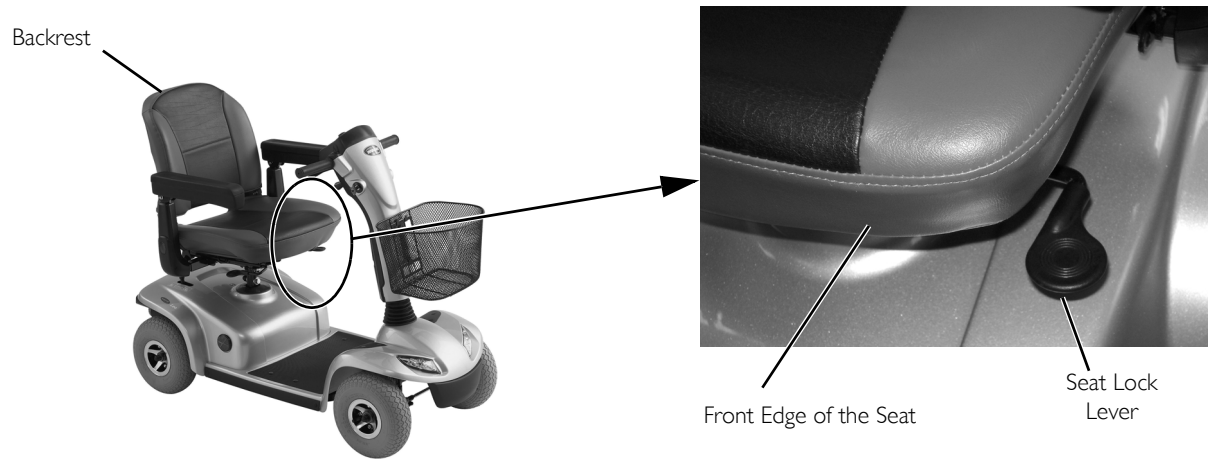

FIGURE 7.1 Removing/Installing the Seat

7.2 Adjusting Seat Height



For this procedure, refer to FIGURE 7.2.

1. Remove the seat. Refer to [Removing/Installing the Seat](#) on page 33.
2. Pull up to remove the top shroud (Detail “A”) and expose the seat post and mounting hardware (Detail “B”).
3. Remove the mounting screw, two washers, locknut and cap that secure the seat post to the frame tube (Detail “C”).
4. Align the frame tube mounting hole with one of five seat post mounting holes to achieve desired seat height.
5. Install one washer onto the mounting screw.
6. Insert the mounting screw through the frame tube and seat post.
7. Install the remaining washer onto the mounting screw.
8. Install the locknut and cap onto the mounting screw to secure the seat post to the frame tube.
9. Install the top shroud (Detail “A”).
10. Install the seat. Refer to [Removing/Installing the Seat](#) on page 33.

7 SEAT AND ARMS

DETAIL "A" - TOP SHROUD



DETAIL "B" - TOP SHROUD REMOVED

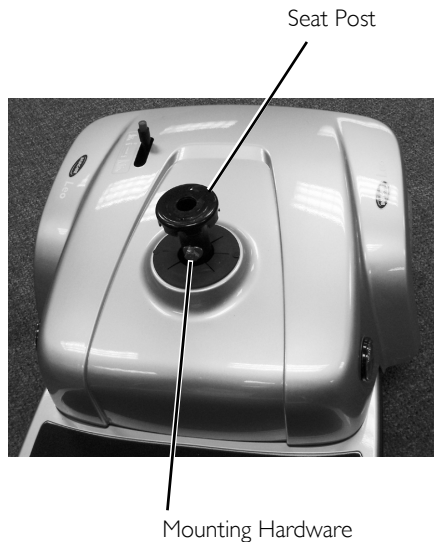

DETAIL "C" - SEAT POST MOUNTING HARDWARE

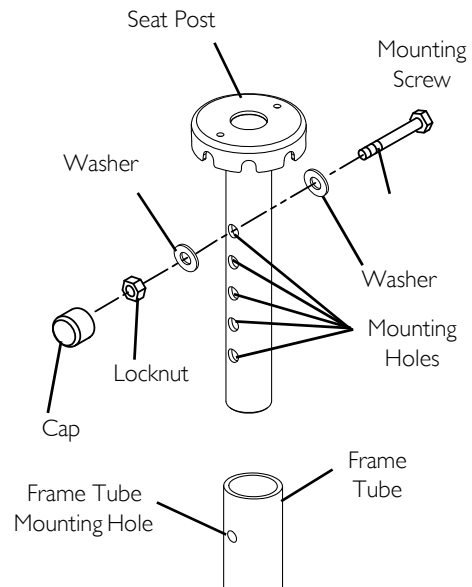

FIGURE 7.2 Adjusting Seat Height

7.3 Adjusting 90° Seat Swivel



WARNING

Ensure that seat is locked into the forward position before and during operation of the scooter. Otherwise, injury to the user and/or damage to the scooter may result.

CAUTION

Use the seat swivel option with caution when accessories are installed (such as safety flag, crutch/cane holder, etc.). Otherwise, damage to the scooter or property may occur.



For this procedure, refer to FIGURE 7.3.

1. Pull up the seat lock lever to unlock the seat.
2. Rotate the seat to the desired position.
3. Release the seat lock lever to lock the seat in the desired position.



Ensure that the seat is locked in the forward facing position before operating the scooter.

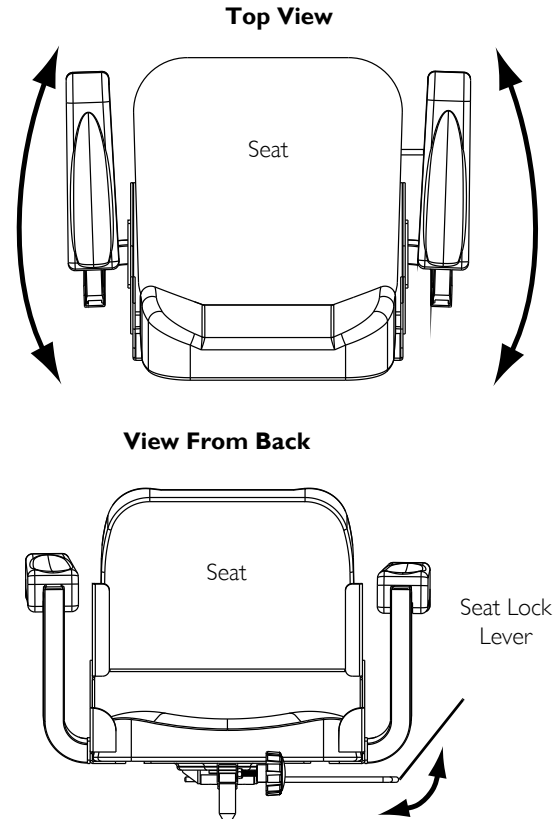

FIGURE 7.3 Adjusting 90° Seat Swivel

7 SEAT AND ARMS

7.4 Adjusting the Seat Position Forward/Rearward



For this procedure, refer to FIGURE 7.4.

The seat position lever is located on the right side of the seat.

1. Pull the seat position lever to disengage the seat.
2. Slide the seat forward or rearward into the desired position.
3. Release the lever to lock the seat in position.

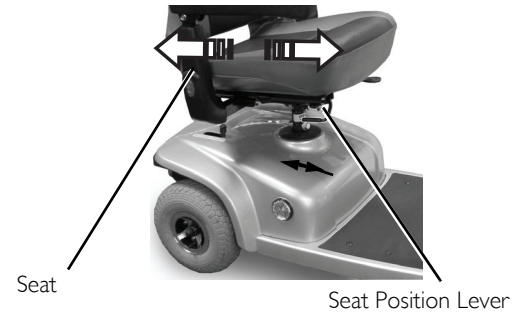

FIGURE 7.4 Adjusting the Seat Position Forward/Rearward

7.5 Adjusting the Arm Width



For this procedure, refer to FIGURE 7.5.



WARNING

DO NOT pull the arm tube out of the seat frame beyond the STOP label on the armrest. Otherwise, the arm tube may fall out of the seat frame and cause injury or damage.

1. Loosen the knob securing the arm tube to the seat frame.
2. Push the arm in or out to the desired position.



FIGURE 7.5 Adjusting the Arm Width

7.6 Replacing Armrest Pad

i For this procedure, refer to FIGURE 7.6.

1. Remove the mounting screw and washer that secure the arm pad to the arm.
2. Remove the old arm pad.
3. Use the mounting screw and washer to install the new arm pad. Securely tighten.
4. If necessary, repeat STEPS 1-3 to replace the other armrest pad.

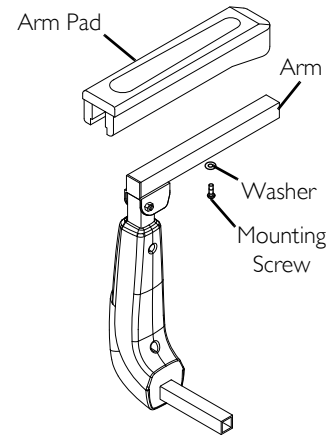

FIGURE 7.6 Replacing Armrest Pad

7.7 Adjusting Armrest Angle

i For this procedure, refer to FIGURE 7.7.

1. Lift the armrest up.
2. Loosen the jam nut.
3. Rotate the screw up or down for the desired arm angle.
4. Tighten the jam nut.
5. If necessary, repeat STEPS 1-3 for the other armrest.

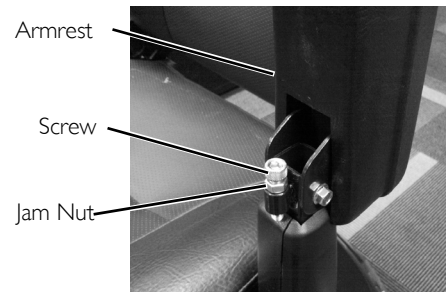

FIGURE 7.7 Adjusting Armrest Angle

7 SEAT AND ARMS

7.8 Installing the Seat Positioning Strap

i For this procedure, refer to FIGURE 7.8.

1. Locate the mounting bracket (Detail “A”) under the rear of the seat.
2. Secure one side of the seat positioning strap to the mounting bracket using the bolt and nut (Detail “B”).

i The nut should go towards the center of the scooter.

3. Repeat STEPS 1-2 on the opposite side of the seat with the remaining side of the seat positioning strap.

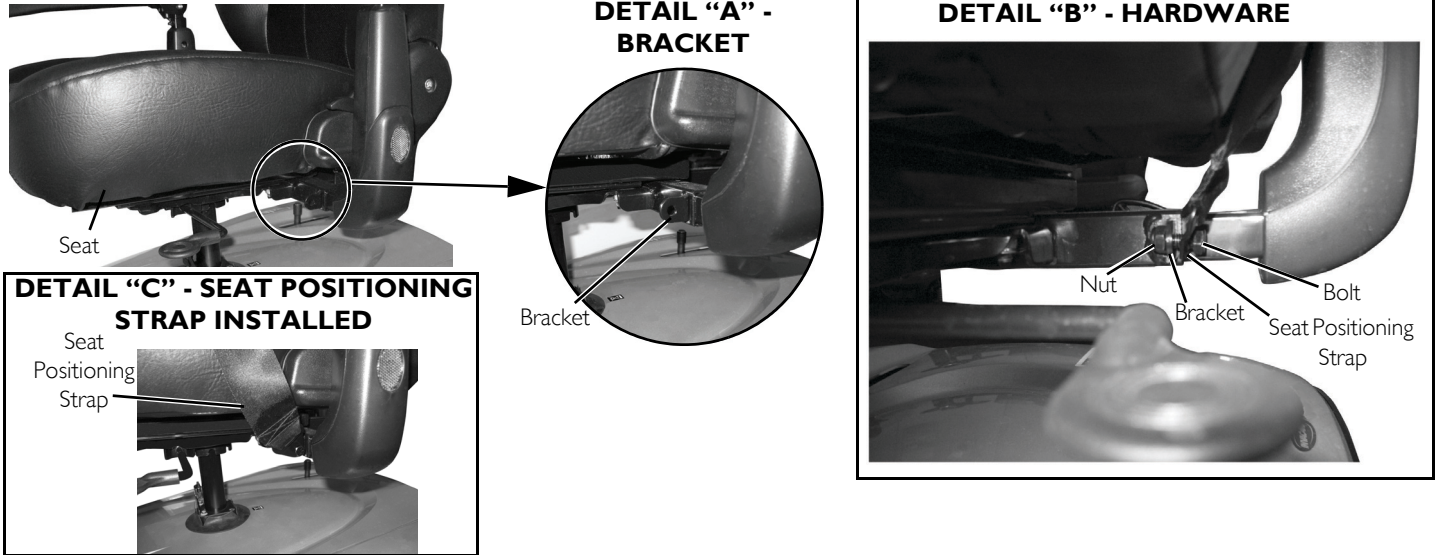

FIGURE 7.8 Installing the Seat Positioning Strap

8 Tiller Adjustment

8.1 Adjusting the Tiller Angle



WARNING

Before performing any maintenance, adjustment or service, turn power Off and remove key from ignition.

DO NOT hang items off of the tiller adjustment lever.

Ensure that tiller is properly adjusted before driving the scooter.

After making any tiller angle adjustments and before use, the tiller MUST be securely locked into position. Otherwise, a fall from the scooter could occur causing bodily injury and/or damage to the scooter. Gently, push/pull against tiller to ensure that the tiller is securely engaged into the adjustment plate.



For this procedure, refer to FIGURE 8.1.

The powered scooters feature an adjustable tiller. The tiller locks into one of three positions. The tiller can also be folded down for transportation and storage.

1. Pull and hold the tiller adjustment lever.
2. Move the tiller to the desired position.
3. Release the tiller adjustment lever to lock the tiller into the desired position.
4. Gently push/pull against tiller to ensure that the tiller is securely locked.

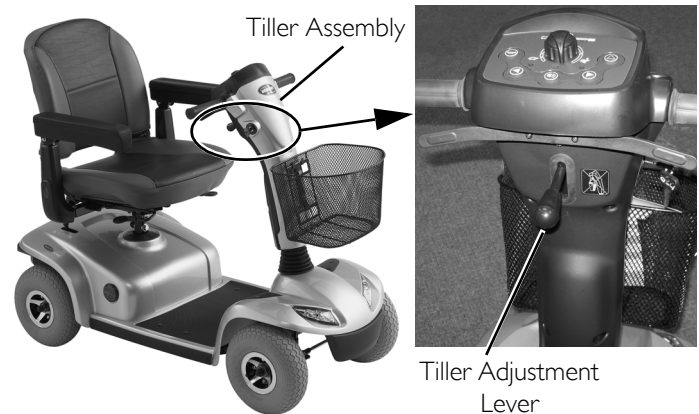

FIGURE 8.1 Adjusting the Tiller Angle

9 Wheels and Casters



WARNING

After any adjustments, repair or service and before use, make sure that all attaching hardware is tightened securely - otherwise injury or damage may result.

Before performing any maintenance, adjustment or service, turn power Off and remove key from ignition.

9.1 Removing/Installing the Drive Wheels



For this procedure, refer to FIGURE 9.1 on page 42.

This procedure applies to the rear wheels of the four wheel and three wheel models.

Removing

1. Turn power off and remove the key from the ignition.
2. Remove the seat. Refer to Removing/Installing the Seat on page 33.
3. Place the rear frame assembly (not shown) up on blocks so that the drive wheels are off the ground.
4. Remove the cap, locknut and small washer from the threaded end of the drive shaft.
5. Remove the existing drive wheel assembly from the drive shaft.



Use a wheel puller if necessary to remove the wheel from the drive shaft.

6. Remove the large washer from the drive shaft.
7. Remove keystone from drive shaft. Set aside.
8. If necessary, repeat STEPS 1-7 to remove other drive wheel.

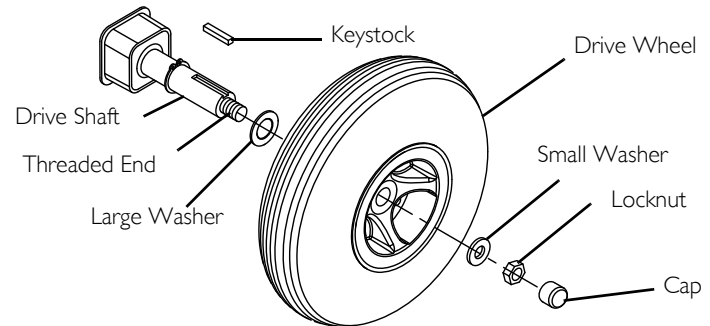

FIGURE 9.1 Removing/Installing the Drive Wheels

Installing

1. Place keystone in cutout on drive shaft as shown in FIGURE 9.1.



The keystone in the drive shaft **MUST** lineup with the cutout in the wheel hub.

If necessary, use a rubber hammer to gently tap drive wheel completely into position on the drive shaft.

2. Install the large washer onto the drive shaft.
3. Install the drive wheel onto the drive shaft.
4. Secure wheel to drive shaft by installing the small washer and locknut onto the threaded end of the drive shaft. Securely tighten.
5. Install the cap.
6. Repeat STEPS 1-5 to install the other drive wheel.
7. Install the seat. Refer to [Removing/Installing the Seat](#) on page 33.

9.2 Removing/Installing the Front Wheels - Four Wheel Models



For this procedure, refer to FIGURE 9.2 on page 44.

Take note of position and orientation of wheel and mounting hardware before removing.

Removing

1. Turn power off and remove the key from the ignition.
2. Place the front of the powered scooter up on blocks so that the front wheels are off the ground.
3. Remove the cap, locknut and washer that secure the front wheel to the front axle.
4. Remove the front wheel from the front axle.

Installing

1. Align the front wheel with the front axle.
2. Use the washer and locknut to secure the front wheel to the front axle.
3. Securely tighten the front wheel mounting hardware.
4. Install the cap.

9 WHEELS AND CASTERS

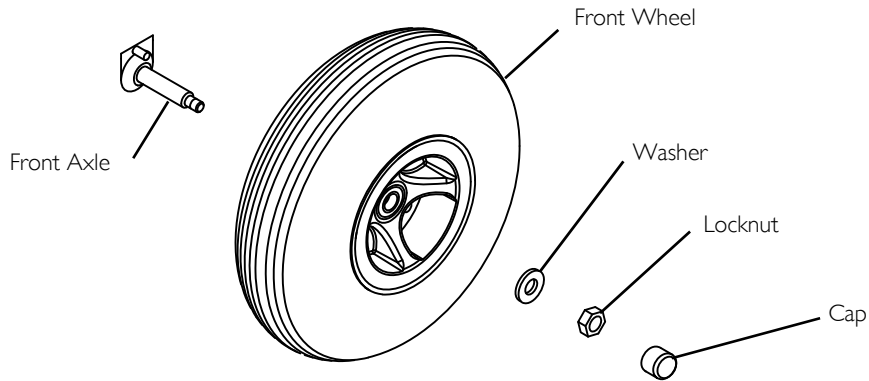

FIGURE 9.2 Removing/Installing the Front Wheels - Four Wheel Models

9.3 Removing/Installing the Front Wheels - Three Wheel Models



For this procedure, refer to FIGURE 9.3.

Take note of position and orientation of wheel and mounting hardware before removing.

Removing

1. Turn power off and remove the key from the ignition.
2. Place the front of the powered scooter up on blocks so that the front wheels are off the ground.
3. Remove the bolt, axle, washer, nut and two spacers that secure the wheel to the fork.
4. Remove the wheel from the fork.

Installing

1. Use the bolt, axle, washer, nut and two spacers to secure the wheel to the fork.
2. Securely tighten the front wheel mounting hardware.

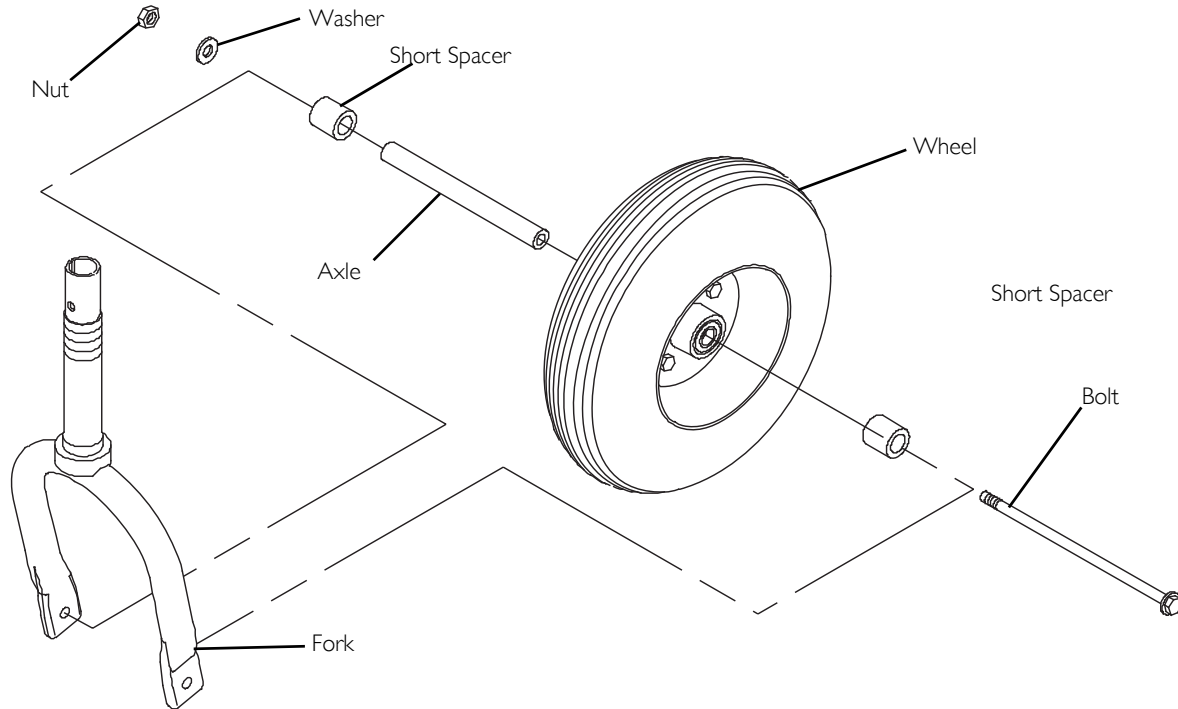

FIGURE 9.3 Removing/Installing the Front Wheels - Three Wheel Models

10 Batteries



WARNING

Before performing any maintenance adjustment or service, turn power off and remove key from ignition.

NEVER allow any of your tools and/or battery cables to contact both battery terminals at the same time. An electrical short may occur and serious personal injury or damage may occur.

The use of rubber gloves is recommended when working with batteries.

DO NOT tip the batteries. Keep the batteries in an upright position.

Invacare strongly recommends that battery installation and battery replacement always be done by a qualified technician.

All battery terminals caps (two on the left battery and two on the right battery) **MUST** be installed prior to use.

CAUTION

When connecting the battery cables to the batteries, the battery cables **MUST** be connected to the battery terminals/posts as shown in FIGURE 10.2 - otherwise damage to the battery may result.



If there is battery acid in the bottom of the battery box or on the sides of the batteries, apply baking soda to these areas to neutralize the battery acid. Before reinstalling the existing or new batteries, clean the baking soda from the battery tray or batteries being sure to avoid contact with skin and eyes. Determine source of contamination. Never install/reinstall a battery with a cracked or otherwise damaged case.

10.1 Recommended Battery Type



WARNING

The warranty and performance specifications contained in this manual are based on the use of AGM batteries. Invacare strongly recommends their use as the power source for this unit.

CAUTION

Failure to use the correct battery size and/or voltage may cause damage to the powered scooter and give unsatisfactory performance.



For this procedure, refer to FIGURE 10.1.

The powered scooters are designed to use two 12 volt, 36-Amp-hour (36 AH) batteries.

Recommended battery type is spill proof and requires no maintenance except routine charging.

Charge batteries daily. **DO NOT** allow batteries to completely discharge.

Invacare recommends that both batteries be replaced if one battery is defective.

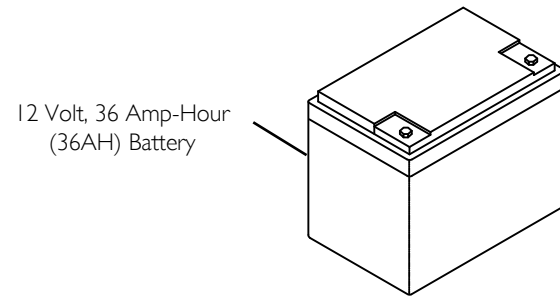

FIGURE 10.1 Recommended Battery Type

10 BATTERIES

10.2 Removing/Installing the Batteries



For this procedure, refer to FIGURE 10.2 on page 49.

Removing

1. Turn power off and remove the key from the ignition.
2. Remove the seat. Refer to [Removing/Installing the Seat](#) on page 33.
3. Pull up to remove the rear cover (Detail “A” of FIGURE 10.2).
4. Open the battery retention strap (Detail “B” of FIGURE 10.2).
5. Disconnect the battery harness connectors.
6. Remove the batteries from the base frame (Detail “C” of FIGURE 10.2).
7. Pull the battery terminal covers up on the battery wiring harnesses to expose the mounting screws (Detail “D” of FIGURE 10.2).
8. Disconnect the battery wiring harnesses from the batteries. Remove the mounting screws securing the:
 - A. NEGATIVE (-) BLACK battery cables to the NEGATIVE (-) battery terminals.
 - B. POSITIVE (+) RED battery cables to the POSITIVE (+) battery terminals.

Installing

1. Connect the battery wiring harnesses to the new batteries (Detail “D” of FIGURE 10.2). Use the mounting screws to secure the:
 - A. NEGATIVE (-) BLACK battery cables to the NEGATIVE (-) battery terminals.
 - B. POSITIVE (+) RED battery cables to the POSITIVE (+) battery terminals.
2. Slide the battery terminal covers down to cover the battery terminals.
3. Install the two new batteries into the base frame (Detail “C” of FIGURE 10.2).



Orient the batteries as shown in Detail “B” of FIGURE 10.2.

4. Connect the battery harness connectors.
5. Secure the batteries to the base frame using the battery retention strap. Securely tighten.



The battery retention strap should go under the battery harnesses as shown in Detail “B” of FIGURE 10.2.

6. Install the rear cover (Detail “A” of FIGURE 10.2).
7. Reinstall the seat. Refer to [Removing/Installing the Seat](#) on page 33.

DETAIL "A" - PREPARING TO REMOVE BATTERIES



DETAIL "B" - BATTERY RETENTION STRAP AND HARNESS CONNECTOR

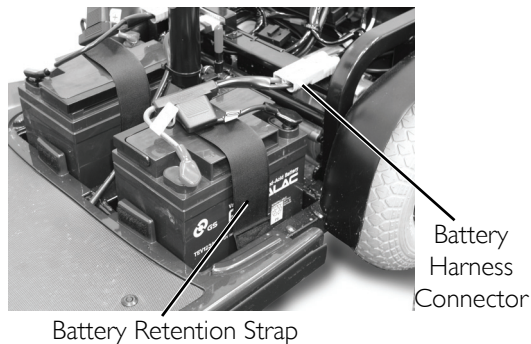

DETAIL "C" - BATTERY REMOVED

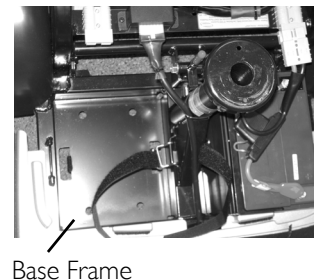

DETAIL "D" - BATTERY HARNESS

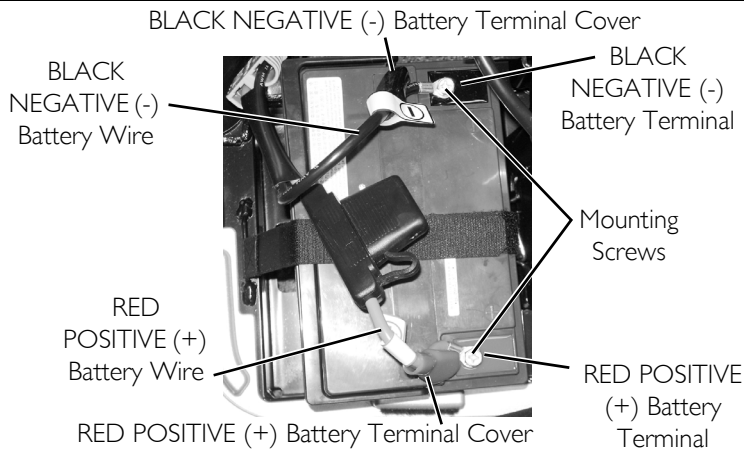

FIGURE 10.2 Removing/Installing the Batteries

10 BATTERIES

10.3 Charging the Batteries



WARNING

NEVER attempt to recharge the batteries by attaching cables directly to the battery terminals or clamps.
DO NOT attempt to recharge the batteries and operate the powered scooter at the same time.
Only use the provided charger with this product.

CAUTION

New batteries MUST be fully charged prior to initial use of the powered scooter.

DO NOT sit in the scooter while recharging the batteries.

ALWAYS charge new batteries before initial use or battery life will be reduced.

As a general rule, you should recharge your batteries as frequently as possible to assure the longest possible life and to minimize required charging time. Plan to recharge them when you do not anticipate using the powered scooter.



The range per battery charge using recommended batteries should be approximately five to nine hours of typical operation. Extensive use on inclines may substantially reduce per charge mileage.

1. Turn the key to the Off position.
2. Move the battery charger port cap to expose the battery charger port.



The battery charger port is located on the left side of the scooter.

3. Plug one end of the battery charger cable into the battery charger port.
4. Plug the other end of the battery charger cable into a 110-volt wall outlet (Detail "A").



The battery charger power LED will be GREEN to indicate that the charger power is On.

The battery charging LED will be ORANGE while charging. If the battery charging LED turns GREEN immediately and the battery is not charged, contact a Dealer or Invacare for assistance. If the battery charging LED is Off, the battery is already fully charged.

5. Allow the batteries to charge until the charging LED turns GREEN.



If the charging LED does not turn from ORANGE to GREEN contact a Dealer or Invacare for assistance.

6. Unplug the battery charger from the wall outlet.
7. Unplug the battery charger from the scooter.
8. Move the battery charger port cap to cover the battery charger port.

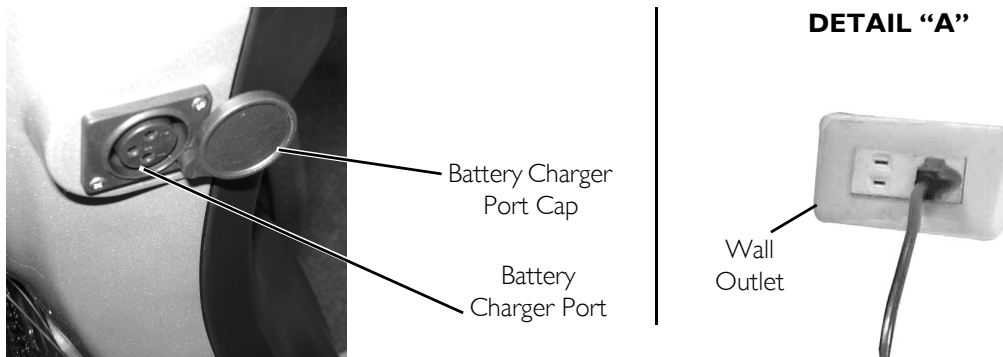

FIGURE 10.3 Charging the Batteries

II Transporting



WARNING

After any adjustments, repair or service and before use, make sure that all attaching hardware is tightened securely - otherwise injury or damage may result.

Before performing any maintenance, adjustment or service, turn power off and remove key from ignition.

DO NOT lift the scooter by the rear shroud - otherwise damage to the scooter may occur.

II.1 Transporting the Scooter



For this procedure, refer to FIGURE 11.1 on page 52.

Disassembling

1. Turn power off and remove the key from the ignition.
2. Remove the basket.
3. Remove the seat. Refer to [Removing/Installing the Seat](#) on page 33.
4. Remove the batteries. Refer to [Removing/Installing the Batteries](#) on page 48.
5. Disconnect the main wiring harness connector.
6. Hold the seat post with one hand.
7. With the other hand, push the release lever to the rear of the scooter.
8. Lift the seat post to separate the front frame assembly from the rear frame assembly.
9. Fold tiller down to lowest locked position. Refer to [Adjusting the Tiller Angle](#) on page 41.

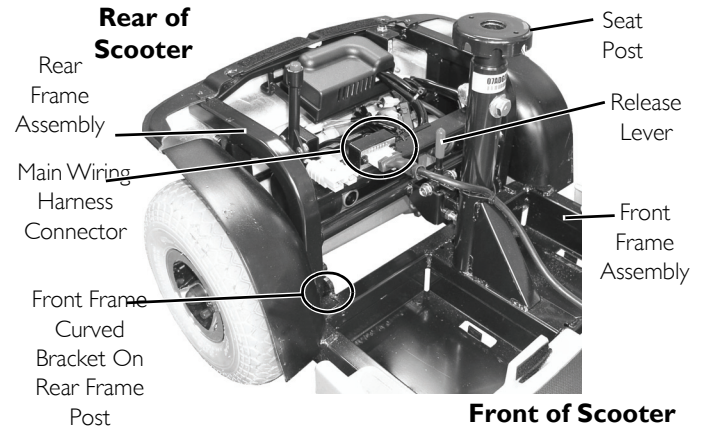

FIGURE 11.1 Transporting the Scooter

Assembling

1. Unfold tiller. Refer to [Adjusting the Tiller Angle](#) on page 41.
2. Hold the seat post and align the curved brackets on the front frame assembly with the posts on the rear frame assembly.
3. While holding the seat post, slowly pivot the front frame assembly down until the release lever locks.
4. Ensure the release lever is locked and the front and rear frame assemblies are connected.
5. Connect the main wiring harness connector.
6. Install the batteries. Refer to [Refer to Removing/Installing the Batteries](#) on page 48.
7. Install the seat. Refer to [Removing/Installing the Seat](#) on page 33.
8. Install the basket.

12 Maintenance



WARNING

After any adjustments, repair or service and before use, make sure that all attaching hardware is tightened securely - otherwise, injury or damage may occur.

Before performing any maintenance, adjustment or service, turn power Off and remove key from ignition.

DO NOT overtighten hardware attaching to the frame. This could cause damage to the frame.

When storing scooter for prolonged periods of time, remove batteries. Refer to [Removing/Installing the Batteries](#) on page 48. After reinstallation, always recharge batteries before use. Refer to [Charging the Batteries](#) on page 50.

Use care in storage. DO NOT allow any metallic objects to contact the exposed terminals.

CAUTION

Only use a damp cloth and gentle detergent for cleaning. DO NOT use any abrasive or scouring liquids.

12.1 Suggested Maintenance Procedures

1. Before using the powered scooter, make sure all nuts and bolts are tight. Check any parts for damage or wear and replace. Check all parts for proper adjustment.
2. Ensure that batteries are properly maintained and charged as required.
3. The wheels and tires should be checked periodically for cracks and wear, and should be replaced by a qualified technician.
4. Regularly check for loose nuts and/or bolts in the front and drive wheels. If loose, have them adjusted by a qualified technician.
5. Clean dirt, dust and grease from exposed components.
6. Periodically have the bearings of the front wheel checked to make sure they are clean and free from moisture.

13 Troubleshooting

13.1 General Troubleshooting

SYMPTOM	PROBABLE CAUSE	SOLUTION
Limited Driving Distance.	Battery not charged long enough. Batteries weak, won't hold charge.	Charge batteries overnight or ensure eight hours of charge between use. Replace batteries. Refer to Removing/Installing the Batteries on page 48.
Batteries not Charging.	Charger not working. Battery connections loose. No current at wall outlet. Bad connection on charger, charger cable, plug or internal wiring problem.	Replace charger. Contact Dealer or a qualified technician. Check all connections. Secure connections. Refer to Removing/Installing the Batteries on page 48. Switch another wall outlet. Replace charger or internal repairs required. Contact Dealer or a qualified technician.
Batteries draw excessive current when charging.	Battery failure.	Replace batteries. Refer to Removing/Installing the Batteries on page 48.
Battery indicator shows the charge level is low - too soon after being recharged.	Charger not working. Weak batteries.	Have charger checked. Service or replace the charger. Contact Dealer or a qualified technician. Replace batteries. Refer to Removing/Installing the Batteries on page 48.

13 TROUBLESHOOTING

SYMPTOM	PROBABLE CAUSE	SOLUTION
Scooter will not drive.	<p>Error</p> <p>Brake release lever disengaged.</p> <p>Batteries require charging.</p> <p>Key not fully plugged in.</p> <p>Charger plugged in.</p> <p>Fuse blown in battery box.</p> <p>Battery connections loose.</p>	<p>Check service indicator light on control panel (FIGURE 6.1 on page 26). If flashing, count the number of flashes and refer to <u>Service Indicator Error Codes</u> on page 57.</p> <p>Engage brake release lever. Refer to <u>Engaging/Disengaging the Brake Release Lever</u> on page 29.</p> <p>Charge batteries. Refer to <u>Charging the Batteries</u> on page 50.</p> <p>Ensure key is inserted fully into keyswitch.</p> <p>Unplug charger from scooter.</p> <p>Contact Dealer or qualified technician.</p> <p>Check all connections. Secure connections. Refer to <u>Removing/Installing the Batteries</u> on page 48.</p>
Status bar indicator is blinking.	An error has occurred.	Count the number of blinks and refer to <u>Service Indicator Error Codes</u> on page 57.

13.2 Service Indicator Error Codes



For the following table, refer to FIGURE 6.1 on page 26.

FLASH	DESCRIPTION	SCOOTER STATUS	MEANING
1	Battery Low	Scooter continues to drive	The batteries are running low. • Recharge the batteries.
2	Low Battery Fault	Scooter stops driving	The batteries have run out of charge. • Recharge the batteries.
3	High Battery Fault	Scooter stops driving	Battery voltage is too high. This may occur if overcharged &/or traveling down a long slope. • If traveling down a slope, reduce your speed to minimize the amount of regenerative charging. • Turn the scooter off and on again. • If the battery charger is connected, disconnect it from the scooter. • Check the battery and associated connections and wiring.
4	Current Limit Time-out	Scooter stops driving	The motor has been exceeding its maximum current rating for too long. This may be due to a faulty motor. • Check the motor and associated connections and wiring. Contact your Invacare dealer. • Turn the scooter off, leave for a few minutes and turn back on again.
5	Park Brake Fault	Scooter stops driving	Either a park brake release switch is active or the park brake is faulty. • Check the park brake and associated connections and wiring. • Ensure any associated switches are in their correct positions. • Contact your Invacare Dealer.
6	Throttle OONAPU	Scooter stops driving	The Throttle is out of neutral when turning the controller on. • Ensure the throttle is in neutral when turning the controller on. • The Throttle may require re-calibration. Contact your Invacare Dealer.
7	Speed Pot Fault	Scooter stops driving	The throttle, speed limit pot, SRW or their associated wiring may be faulty. • Check the throttle and speed pot and associated connections and wiring. Contact your Invacare Dealer.
8	Motor Voltage Fault	Scooter stops driving	The motor or its associated wiring is faulty. • Check the motor and associated connections and wiring. Contact your Invacare Dealer.
9	Other error	Scooter stops driving	The controller may have an internal fault. • Check all connections & wiring. Contact your Invacare Dealer.
10	Push/Rollaway Fault	Scooter stops driving	The scooter has exceeded the Push or Rollaway speed limits. • Turn the scooter off and then on again.

NOTES

Notes

Notes



Yes, you can.[®]

For more information regarding Invacare products, parts, and services, please visit www.invacare.com.

Invacare Corporation

www.invacare.com

USA

One Invacare Way
Elyria, Ohio USA
44036-2125
800-333-6900

Canada

570 Matheson Blvd E Unit 8
Mississauga Ontario
L4Z 4G4 Canada
800-668-5324

© 2011 Invacare Corporation. All rights reserved. Republication, duplication or modification in whole or in part is prohibited without prior written permission from Invacare. Trademarks are identified by [™] and [®]. All trademarks are owned by or licensed to Invacare Corporation or its subsidiaries unless otherwise noted.

Part No. 1163141

Rev B - 05/11



Free Manuals Download Website

<http://myh66.com>

<http://usermanuals.us>

<http://www.somanuals.com>

<http://www.4manuals.cc>

<http://www.manual-lib.com>

<http://www.404manual.com>

<http://www.luxmanual.com>

<http://aubethermostatmanual.com>

Golf course search by state

<http://golfingnear.com>

Email search by domain

<http://emailbydomain.com>

Auto manuals search

<http://auto.somanuals.com>

TV manuals search

<http://tv.somanuals.com>