

TOP END[®]
***Recumbent
Handcycle Series***
Top End XLT[™]
Top End XLT Jr.
Top End XLT Pro
Top End XLT Gold
Top End Force[™]

DEALER: This manual **MUST** be given to the user of the handcycle.

USER: **BEFORE** using this handcycle, read this manual and save for future reference.

For more information regarding
Invacare products, parts, and services,
please visit www.invacare.com



Yes, you can.®

⚠ WARNING

DO NOT USE THIS PRODUCT OR ANY AVAILABLE OPTIONAL EQUIPMENT WITHOUT FIRST COMPLETELY READING AND UNDERSTANDING THESE INSTRUCTIONS AND ANY ADDITIONAL INSTRUCTIONAL MATERIAL SUCH AS OWNER'S MANUALS, SERVICE MANUALS OR INSTRUCTION SHEETS SUPPLIED WITH THIS PRODUCT OR OPTIONAL EQUIPMENT. IF YOU ARE UNABLE TO UNDERSTAND THE WARNINGS, CAUTIONS OR INSTRUCTIONS, CONTACT A HEALTHCARE PROFESSIONAL, DEALER OR TECHNICAL PERSONNEL BEFORE ATTEMPTING TO USE THIS EQUIPMENT - OTHERWISE, INJURY OR DAMAGE MAY OCCUR.

⚠ ACCESSORIES WARNING

INVACARE PRODUCTS ARE SPECIFICALLY DESIGNED AND MANUFACTURED FOR USE IN CONJUNCTION WITH INVACARE ACCESSORIES. ACCESSORIES DESIGNED BY OTHER MANUFACTURERS HAVE NOT BEEN TESTED BY INVACARE AND ARE NOT RECOMMENDED FOR USE WITH INVACARE PRODUCTS.

NOTE: Updated versions of this manual are available on www.invacare.com.

TABLE OF CONTENTS

REGISTER YOUR PRODUCT	7
DEALER/TECHNICIAN INFORMATION	8
SPECIAL NOTES	8
TYPICAL PRODUCT PARAMETERS	10
SECTION 1—GENERAL GUIDELINES	12
Proper Fit	12
Operating Information.....	12
Tire Pressure	14
Weight Limitation.....	14
SECTION 2—SAFETY AND HANDLING	15
Safety and Handling of the Handcycle.....	15
Stability and Balance.....	15
A Note to Handcycle Assistants.....	15
Percentage of Weight Distribution	16
Transferring Into/Out of the Handcycle	16
SECTION 3—SAFETY INSPECTION	18
Safety Inspection Checklist.....	18
Inspect/Adjust Initially	18
Inspect/Adjust Weekly.....	19
Inspect/Adjust Monthly.....	20
Inspect/Adjust Periodically.....	20
Troubleshooting.....	21
Maintenance	21
Maintenance Safety Precautions	21
Suggested Maintenance Procedures	21
SECTION 4—INITIAL SETUP	23
Initial Setup.....	23

TABLE OF CONTENTS

SECTION 5—OPERATION	26
Riding the Handcycle	26
Shifting Gears.....	27
Seven Speed Hub	27
Backing-Up	29
Braking	29
Reversing Drum Brakes.....	29
Hand Brakes/Hands-On Brakes.....	30
Using Parking Brake	30
Steering/Cornering.....	31
SECTION 6—RIDING POSITION	32
Replacing/Adjusting the Footrest and Leg Guard	32
Replacing/Adjusting Footrest.....	32
Replacing/Adjusting Leg Guard	32
Using/Replacing Footrest Strap	33
Using Footrest Strap	33
Replacing Footrest Strap	33
Adjusting Hand Crank	34
Adjusting Hand Crank Height - All Models Except Top End XLT Gold.....	34
Adjusting Top End XLT Gold Hand Crank.....	35
Adjusting Seat Fore/Aft - All Models Except XLT Gold and Top End Force.....	36
Adjusting Seat Fore/Aft - XLT Gold and Top End Force Only	37
Adjusting Seat Height - All Models Except XLT Gold and Top End Force	38
Adjusting Back Angle - All Models Except XLT Gold and Top End Force	39
Adjusting Back Angle - XLT Gold.....	40
Adjusting Back Height - Wide Back Option Only	41
SECTION 7—WHEELS	42
Installing/Adjusting the Rear Wheel and Quick-Release Axles.....	42
Installing the Rear Wheels with Threaded Axles.....	43
Replacing Tire/Tube and Tuning/Replacement of Spokes	43
Tire Pressure	43
Determining/Adjusting Toe In/Toe Out.....	44
Determining Toe In/Toe Out	44
Adjusting Toe In/Toe Out	45
Replacing Camber Inserts.....	45

TABLE OF CONTENTS

SECTION 8—SERVICE PROCEDURES	46
Replacing the Fork/Crank Assembly	46
Replacing the Crank Arms - XLT Gold, XLT PRO and Top End Force	49
Replacing the Left Side Crank Arms.....	49
Replacing the Right Side Crank Arms	49
Installing/Removing/Adjusting the Road Crown Compensator	50
Installing Road Crown Compensator.....	50
Removing Road Crown Compensator	51
Adjusting Road Crown Compensator	51
Installing/Removing/Adjusting the Steering Dampener - For Top End XLT Gold and Force Only.....	52
Installing Steering Dampener.....	52
Removing Steering Dampener	52
Adjusting Steering Dampener	52
Installing Seven Speed Shifter Cable.....	53
Adjusting/Replacing Seven Speed Shifter.....	54
Installing/Adjusting Seven Speed Hub Chain	54
Seven Speed Hub Chain Installation	54
Adjusting Seven Speed Hub Chain.....	55
Installing/Adjusting Twenty-Seven Speed Cassette Chain.....	55
Installing Twenty-Seven Speed Cassette Chain.....	55
Adjusting Twenty-Seven Speed Cassette Chain	56
Adjusting/Replacing the Parking Brake	57
Adjusting the Parking Brake	57
Replacing the Parking Brake	57
Replacing Seat Upholstery	58
Replacing Back Upholstery	59
Replacing Wide Back Upholstery.....	59
Replacing Narrow Back Upholstery	59

TABLE OF CONTENTS

SECTION 9—OPTIONS	60
Installing Rear Safety Light.....	60
Batteries	60
Mounting the Safety Light.....	60
Operating the Safety Light	60
Installing the Water Bottle.....	61
Installing/Using the Tow Bar	61
Installing the Draft Bumper	62
Installing the Safety Flag.....	62
Using Safety Helmet.....	62
Installing Seat Positioning Strap.....	63
Installing the Computer	63
Installing Hand Crank Handles	64
Horizontal Handles/Delrin Handles.....	64
Vertical Handles	64
Tri-pin Quad Handles	64
V or S Crank Handles	64
Installing V/S Crankarm Handles.....	64
For Models Made Before 7/12/07	64

For Models Made After 7/12/07	65
Installing Gloves	66
Mountain Drive Transmission Option.....	66
Switching to Mountain Drive Transmission Option	66
Mountain Drive Transmission Option Maintenance.....	66
Using the Travel Ready Option.....	67
Removing/Installing the Camber Bar.....	67
Removing/Installing the Fork - Travel Ready XLT PRO Equipped with Road Crown Compensator	68
Removing the Fork	68
Installing the Fork.....	68
Removing/Installing the Fork - XLT Gold, and Top End Force Equipped with Steering Dampener	69
Removing the Fork	69
Installing the Fork.....	69
Removing/Installing the Front Wheel - XLT Gold, XLT Pro and XLT with Speed Cassette Chain	70
Removing the Front Wheel	70
Installing the Front Wheel	71
Assembling/Using/Adjusting the Handcycle Rack.....	71
Assembling the Handcycle Rack	71
Using the Handcycle Rack.....	72
Adjusting the Handcycle Rack.....	73
Using the Alignment Gauge.....	74
LIMITED WARRANTY	75

REGISTER YOUR PRODUCT

The benefits of registering include:

1. Safeguarding your investment.
2. Ensuring long-term maintenance and servicing of your product.
3. Receiving updates with product information, maintenance tips and industry news.

Register ONLINE at warranty.invacare.com

Please have your model number and purchase date available to complete your registration.

Any registration information you submit will only be used by Invacare Corporation and protected as required by applicable laws and regulations.

DEALER/TECHNICIAN INFORMATION

The term "qualified technician" in this manual refers to an Invacare qualified technician or a Shimano® certified bicycle repair technician.

SPECIAL NOTES

Signal words are used in this manual and apply to hazards or unsafe practices which could result in personal injury or property damage. Refer to the table below for definitions of the signal words.

SIGNAL WORD	MEANING
DANGER	Danger indicates an imminently hazardous situation which, if not avoided, will result in death or serious injury.
WARNING	Warning indicates a potentially hazardous situation which, if not avoided, could result in death or serious injury.
CAUTION	Caution indicates a potentially hazardous situation which, if not avoided, may result in property damage.

NOTICE

THE INFORMATION CONTAINED IN THIS DOCUMENT IS SUBJECT TO CHANGE WITHOUT NOTICE.

HANDCYCLE USER

As a manufacturer of handcycles, Invacare endeavors to supply a handcycle to meet many needs of the end user. However, final selection of a handcycle to be used by an individual rests solely with the user and his/her health care professional capable of making such a selection.

HANDCYCLE TIE-DOWN RESTRAINTS AND SEAT POSITIONING STRAPS

Invacare recommends that handcycle users **NOT** be transported in vehicles of any kind while in a handcycle. As of this date, the Department of Transportation has not approved any tie-down systems for transportation of a user while in a handcycle, in a moving vehicle of any type.

As regards restraints - seat positioning straps - it is the obligation of the DME dealer, therapists and other health care professionals to determine if a seating positioning strap is required to ensure the safe operation of this equipment by the user. Serious injury can occur in the event of a fall from a handcycle.

Invacare products are specifically designed and manufactured for use in conjunction with Invacare accessories. Accessories designed by other manufacturers have not been tested by Invacare and are not recommended for use with Invacare products.

⚠ WARNING

ALWAYS wear your seat positioning strap. Inasmuch as the seat positioning strap is an option on this handcycle (you may order with or without the seat positioning strap), Invacare strongly recommends ordering the seat positioning strap as an additional safeguard for the handcycle user. The seat positioning strap is a positioning belt only. It is not designed for use as a safety device withstanding high stress loads such as auto or aircraft safety belts. If signs of wear appear, belt **MUST** be replaced immediately.

TYPICAL PRODUCT PARAMETERS

	TOP END XLT	TOP END XLT JR
Seat Width:	14 to 20 inches	14 inches
Seat Depth:	15 inches	15 inches
Seat-to-Floor (approx.):	12, 13, or 14 inches	12, 13, or 14 inches
Back Style:	Adjustable Back Angle 90° - 110°	Adjustable Back Angle 90° - 110°
Back Height Fixed/ Adjustable Angle:	11-14 inches (Wide) 20 inches (Narrow, Tall)	11-14 inches (Wide) 16½ inches (Narrow, Tall)
Footrest:	Adjustable Fore and Aft	Adjustable Fore and Aft
Side - Wheel Clearance:	2 inches - * 2½ inches	2 inches - 2½ inches
Rear Axle:	Quick-Release or Threaded	Quick-Release
Rear Wheel Camber:	15° - Standard	15° - Standard
Wheels/Tires:	26-inch Spoke High Performance 24-inch Cruiser or *Knobby	20-inch Cruiser
Brakes:	Internal reversing drum brakes and parking brake	Internal reversing drum brakes and parking brake
Handles:	Ergonomic, Vertical foam covered or Delrin®	Ergonomic, Vertical foam covered or Horizontal foam covered
Crankset:	Alloy Crankset	Alloy Crankset
Hub:	FRONT - Shimano Nexus® 7 Speed Hub REAR - Precision Black Anodized w/½-inch Quick Release Stainless Axles	FRONT - Shimano Nexus 7 Speed Hub REAR - Precision Black Anodized w/½-inch Quick Release Stainless Axles
Spokes:	14 Gauge Stainless	14 Gauge Stainless
Shift Levers:	Shimano	Shimano
Gears:	7 Speed	7 Speed
Seat Cushion:	Foam Insert - Optional	Foam Insert - Optional
Upholstery:	Nylon	Nylon
Weight:	35 lbs	30-35 lbs
Shipping Weight:	65 lbs	65 lbs
Weight Limitation:	250 lbs	250 lbs
Options:	Mirror, Backpack Hydration System, Computer, Tow Bar, Horizontal Handles, Safety Lights, Helmet and Flag, Seat Positioning Strap, Quad Cuffs, Quad Gloves, Mountain Drive, Bike Rack, Water Bottle and Cage, Tri-pin Quad Handles, Threaded Axles, Leg Guard Attachment, Alignment Gauge, Crutch Holder, Indoor Training Roller	Cordless Computer, Helmet, Quad Cuffs, Quad Gloves, Seat Positioning Strap, Safety Flag, Mirror, Safety Lights, Water Bottle and Cage, Leg Guard Attachment, Crutch Holder, Bike Rack, Cushion, Towbar for handcycle, Backpack Hydration System, Alignment Gauge, Mountain Drive, Tri-pin Quad Handles.

*NOTE: Knobby tires will reduce side wheel clearance to approximately 1-inch.

TYPICAL PRODUCT PARAMETERS

	TOP END XLT PRO	TOP END XLT GOLD
Seat Width:	14 to 18 inches	14 to 18 inches
Seat Depth:	15 inches	15 inches
Seat-to-Floor (approx.):	12, 13 and 14 inches	9 inches
Back Style:	Adjustable Back Angle 90° - 110°	Adjustable Back Angle 50° - 90°
Back Height Fixed/ Adjustable Angle:	11-14 inches (Wide) 18½ inches (Narrow, Tall)	12 inches (Wide) 18 inches (Narrow, Tall)
Footrest:	Adjustable Fore and Aft	Adjustable Fore and Aft
Side - Wheel Clearance:	2 inches - * 2½ inches	2 inches - 2½ inches
Rear Axle:	Quick-Release or Threaded	Quick-Release or Threaded
Rear Wheel Camber:	15° - Standard	9° - Standard
Wheels/Tires:	26-inch Spoke High Performance 24-inch Cruiser or *Knobby	26-inch Spoke High Performance. 24-inch Cruiser or *Knobby
Brakes:	Rapid fire hands-on brake mounted on right pedal. Parking brake on L frame	Rapid fire hands-on brake mounted on right pedal. Parking brake on L frame
Handles:	Ergonomic, Vertical, Ovalized Aluminum mounted on Top End V crankset	Ergonomic, Vertical, Ovalized Aluminum mounted on Top End S or V crankset
Crankset:	Top End V Crankset	Top End S or V Crankset
Hub:	FRONT - Shimano/Top End Components w/ 27 Speed External Cassette REAR - Precision Black Anodized w/½-inch Quick Release Stainless or Threaded Axles	FRONT – Shimano/Top End Components w/ 27 Speed External Cassette REAR - Precision Black Anodized w/½-inch Quick Release Stainless Axles or Threaded Axles
Spokes:	14 Gauge Stainless	14 Gauge Stainless
Shift Levers:	Rapid fire hands-on shifter mounted on right handpedal for lower derailleur, Manual shifter for upper derailleur/chainrings.	Rapid fire hands-on shifter mounted on right handpedal for lower derailleur, Manual shifter for upper derailleur/chainrings.
Gears:	27 Speed	27 Speed
Seat Cushion:	Foam Insert - Optional	Foam Insert - Optional
Upholstery:	Nylon	Nylon-Adjustable Tension
Weight:	30 lbs	30 lbs
Shipping Weight:	65 lbs	65 lbs
Weight Limitation:	250 lbs	250 lbs
Options:	Computer, Tow Bar, Safety Lights, Helmet, Flag, Bike Rack, Water Bottle and Cage, Carbon Fiber Wheels, Leg Guard Attachment, Welded Seat, Travel Option, Alignment Gauge, Backpack Hydration System, Crutch Holder, Drafting Bumper, Indoor Training Roller	Computer, Tow Bar, Safety Lights, Helmet, Flag, Bike Rack, Water Bottle and Cage, Fixed seat frame, Alignment Gauge, Backpack Hydration System, Carbon Fiber Wheels, Crutch Holder, Drafting Bumper, Titanium Parts, Indoor Training Roller

*NOTE: Knobby tires will reduce side wheel clearance to approximately 1-inch.

SECTION I—GENERAL GUIDELINES

⚠ WARNING

SECTION I - GENERAL GUIDELINES contains important information for the safe operation and use of this product.

Proper Fit

The handcycle **MUST** be adjusted to fit the rider. For a proper fit:

- The rider **MUST** be able to see over the hand crank.
- The rider **MUST** have a slightly bent elbow when the hand pedals are toward the front of the handcycle (farthest from the rider's face).
- The rider **MUST** have a slight bend at the knee when feet are in the footrests. Feet should be flat against footrest hoop.
- XLT Series requires a 18' turning radius. If leg touches tire during turn and user cannot sense this, a leg guard attachment is recommended.
- The rider's knees **MUST** not obstruct hand crank operation.

Check the seat position, back angle, quick-release on threaded axles, footrest fore/aft position, hand crank height for proper fit and smooth operation of your handcycle.

Operating Information

Wear your helmet at all times when riding the handcycle.

Before riding your handcycle, check your brakes. Be sure that the brakes and all other features of your handcycle are operating properly.

ALWAYS keep fingers or hands away from the chain while pedaling.

DO NOT let children play near the handcrank or the chain. Otherwise, injury or damage may occur.

The user is responsible for normal upkeep and maintaining the handcycle in proper operating condition.

The manufacturer is not responsible for failure, damage or injury caused by improper operation or maintenance by the end-user.

To determine and establish your particular safety limits, practice transferring activities in the presence of a qualified health care professional before attempting active use of the handcycle.

Before attempting to transfer in or out of the handcycle, every precaution should be taken to reduce the gap distance. Position the handcycle on level ground and as close as possible to the object you are transferring into or out of.

The object you are transferring into or out of **MUST** also be secured before attempting any transfer.

Top End XLT, XLT jr., and XLT Gold Models Only - The parking brake of the handcycle MUST be engaged before attempting any transfer.

Top End XLT Pro Model Only - This model may be ordered with or without a parking brake. If ordered without a parking brake, the handcycle MUST be positioned securely against a stable object before any transfer is attempted. If ordered with the optional parking brake, the parking brake MUST be engaged before attempting any transfer.

Care MUST be taken when operating on roads, streets or highways.

Operation of the handcycle is subject to all traffic rules and regulations. (This may include the use of a safety lights and reflectors for dusk/night riding.)

Give pedestrians the right of way.

Slow down at all street intersections and observe to the left, to the right and back to left again before proceeding.

Use proper hand signals when turning.

DO NOT attempt to move up or down an incline with an ice or oil film.

DO NOT attempt to ride over curbs or obstacles or speed bumps. Doing so may cause your handcycle to "bottom out" and/or turn over and cause bodily harm or damage to the handcycle.

Invacare products are specifically designed and manufactured for use in conjunction with Invacare accessories. Accessories designed by other manufacturers have not been tested by Invacare and are not recommended for use with Invacare products.

DO NOT attempt to lift the handcycle by any removable (detachable) parts. Lifting by means of any removable (detachable) parts of an handcycle may result in injury to the user or damage to the handcycle.

DO NOT stand on the seat or frame of the handcycle.

ALWAYS wear your seat positioning strap. Inasmuch as the seat positioning strap is an option on this handcycle (you may order with or without the seat positioning strap), Invacare strongly recommends ordering the seat positioning strap as an additional safeguard for the handcycle user. The seat positioning strap is a positioning belt only. It is not designed for use as a safety device withstanding high stress loads such as auto or aircraft safety belts. If signs of wear appear, belt MUST be replaced immediately.

With regard to restraints – seat/chest positioning straps – it is the obligation of the DME dealer, therapists and other healthcare professionals to determine if a seat/chest positioning strap is required to ensure the safe operation of this equipment by the user. **SERIOUS INJURY CAN OCCUR IN THE EVENT OF A FALL FROM A WHEELCHAIR.**

Avoid all surface hazards.

DO NOT carry any riders.

DO NOT carry any items that may obstruct your view or prohibit you from operating the handcycle properly.

DO NOT attempt to adjust or clean the internal gear hub with reversing drum brake. This should only be performed by a bicycle professional.

Tire Pressure

DO NOT use your handcycle unless it has the proper tire pressure (p.s.i.). DO NOT overinflate the tires. Failure to follow these suggestions may cause the tire to explode and cause bodily harm.

DO NOT ride on a flat or underinflated tires. Riding on flat or underinflated tires can cause injury, as well as, damage to the tire, tube and handcycle.

Weight Limitation

The Invacare Top End XLT handcycles have a weight limitation of 250 lbs.

A weight limitation label is on the rear axle of the handcycle.

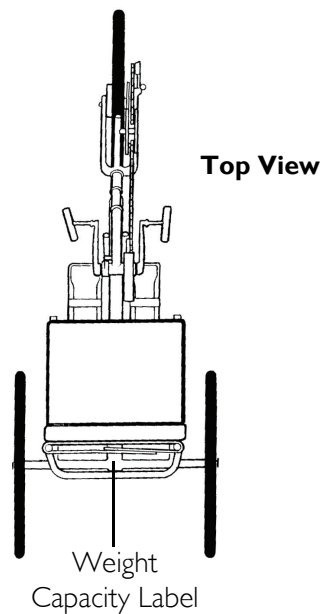

FIGURE I.1 Weight Limitation

SECTION 2—SAFETY AND HANDLING

Safety and Handling of the Handcycle

Requires the close attention of the user as well as the assistant. This manual points out the most common procedures and techniques involved in the safe operation and maintenance of the handcycle. It is important to practice and master these safe techniques until you are comfortable in maneuvering the handcycle.

Use this information only as a basic guide. The techniques that are discussed on the following pages have been used successfully by many.

Individual users often develop skills to deal with daily living activities that may differ from those described in this manual. Invacare recognizes and encourages each individual to try what works best for him/her in overcoming obstacles that they may encounter. Techniques in this manual are a starting point for the new handcycle user and assistant with safety as the most important consideration for all.

Stability and Balance

For stability and proper operation of your handcycle, you **MUST** at all times maintain proper balance. Your handcycle should remain upright and stable during normal daily activities when operated correctly.

Invacare recommends using seat positioning straps for additional safety.

A Note to Handcycle Assistants

When learning assistance techniques for the handcycle, have an experienced assistant help you before attempting it alone.

When you are assisting with a transfer to/from the handcycle, remember to use good body mechanics. Keep your back straight and bend your knees when lifting or positioning the handcycle for the end-user.

Also, be aware of detachable parts. These **MUST NEVER** be used for lifting supports or to move the handcycle, as they may be inadvertently released, resulting in possible injury to the user and/or assistant.

Percentage of Weight Distribution

Transferring in and out of the handcycle will cause a change to the normal balance, the center of gravity, and the weight distribution of the handcycle. To determine and establish your particular safety limits, practice transferring activities in several combinations in the presence of a qualified health care professional before attempting a transfer alone.

Proper positioning is essential for your safety.

Transferring Into/Out of the Handcycle

⚠ WARNING

Before attempting to transfer in or out of the handcycle, every precaution should be taken to reduce the gap distance. Position the XLT on level ground and as close as possible to the object you are transferring into or out of.

The object you are transferring into or out of MUST also be secured before attempting any transfer.

TOP END XLT, XLT JR. AND XLT GOLD MODELS ONLY - The parking brake of the handcycle MUST be engaged before attempting any transfer.

TOP END XLT PRO MODEL ONLY - This model may be ordered with or without a parking brake. If ordered without a parking brake, the handcycle MUST be positioned securely against a stable object before any transfer is attempted. If ordered with the optional parking brake, the parking brake MUST be engaged before attempting any transfer.

CAUTION

When transferring, position yourself as far back as possible in the seat. This will prevent damage to the upholstery.

NOTE: For this procedure, refer to FIGURE 2.1 on page 17.

NOTE: This activity may be performed independently provided you have adequate mobility and upper body strength.

1. Position the handcycle on level ground and as close as possible along side the object to/from which you are transferring.
2. If possible, position the handcycle at a 45° angle to the object to/from which you are transferring.
3. If installed, apply the parking brake on the handcycle.
4. Position the handcycle handles as far forward as possible. This will create more room to transfer.

NOTE: If necessary, lift the front wheel off the ground and rotate the front tire.

5. Secure object that you are transferring into or out of. Apply wheel locks (if installed) if the object is a handcycle.

NOTE: During independent transfer, little or no seat platform will be beneath you. Although it may be difficult to wedge the transfer board between the handcycle seat and the wheelchair seat, use a transfer board if necessary.

NOTE: Refer to STEPS A-F in FIGURE 2.1 for details regarding transfer to/from a handcycle.

6. Shift body weight onto object while transferring.
7. Lift and place left leg past front frame across seat and over center tube.

⚠ WARNING
If installed, parking brake **MUST** be secured.

STEP A: Shift body weight to the edge of the wheelchair upholstery closest to the handcycle.

STEP F: Place both legs onto handcycle footrests and secure safety straps.

⚠ WARNING
Wheel locks **MUST** be engaged if installed.

Handcycle Pedals
(positioned toward the front of the handcycle).

Footrest

Seat Frame

STEP B: Lift and place LEFT leg past front frame across seat and over center tube.

Wheelchair

STEP E: Lift and shift weight down into handcycle seat.

STEP C: Place LEFT hand on the left side of handcycle seat frame, NOT on hand crank.

STEP D: Place RIGHT hand on the wheelchair frame.

**NOTE: The steps in FIGURE 1 are specifically for transfer to/from a wheelchair and DO NOT correspond to the steps in the procedure on the previous page. Follow a similar procedure to transfer to/from an object other than a wheelchair. Refer to the steps on the previous page for more information.*

NOTE: Handcycle shown for clarity.

FIGURE 2.1 Transferring Into/Out of the Handcycle

SECTION 3—SAFETY INSPECTION

Safety Inspection Checklist

NOTE: Every six months, take your Top End XLT to a qualified technician for a thorough inspection and servicing. Regular cleaning will reveal loose or worn parts and enhance the smooth operation of your Top End XLT. For safe and proper operation, your handcycle MUST be cared for just like any other vehicle. Routine maintenance will extend the life and efficiency of your Top End XLT.

NOTE: Invacare recommends that the following adjustments be performed by a qualified technician. Initial adjustments should be made to suit your personal body structure and preference. Thereafter follow these maintenance procedures.

Inspect/Adjust Initially

- Inspect for bent or broken frame.
- Inspect parking brake - Adjust brake shoes to front rim. Check for worn or missing shoes. Check for wax or oil on rim.
- Ensure cable anchor is attached securely to brake arm.
- Ensure internal stopping brakes engages easily.

CAUTION

As with any vehicle, the wheels/casters and tires should be checked periodically for cracks, flat spots and wear, and should be replaced.

- Ensure axle nuts are tight. Wheel should be centered in fork. Keep wheel bearings adjusted and keep spokes tight and wheel in proper alignment.
- Inspect rim and fork assembly for damage.
- Ensure axle nut and wheel mounting nuts are secure.
- Inspect wheels for excessive side movement or binding when lifted and spun.
- Inspect for flat spots, wear and proper inflation.
- Inspect chain/chain guard for damage, rust, tension and stretch. Adjust if necessary. Lubricate each link (3-in-1 oil® or a quality bike lubricant). Check for damage or looseness.
- Adjust shifter/brake cables according to shifter/brake manufacturer's instructions (included with the handcycle).
- Inspect front fork. Keep tight and lubricate (All purpose grease).
- Inspect footrest mounting hardware is tight and footrest secure.
- Inspect footrest straps for wetness and/or damage.

- Inspect seat positioning strap for any signs of wear. Ensure buckle latches. Verify hardware that attaches strap to frame is secure and undamaged. Replace if necessary.
- Inspect upholstery for rips or sagging.
- Clean upholstery with light detergent and water.
- Check that all labels are present and legible. Replace if necessary.
- Ensure that casters are free of debris.

Inspect/Adjust Weekly

- Inspect parking brake - Adjust brake shoes to front rim. Check for worn or missing shoes. Check for wax or oil on rim.
- Ensure cable anchor is attached securely to brake arm.
- Ensure internal stopping brakes engages easily.

CAUTION

As with any vehicle, the wheels/casters and tires should be checked periodically for cracks, flat spots and wear, and should be replaced.

- Ensure axle nuts are tight. Wheel should be centered in fork. Keep wheel bearings adjusted and keep spokes tight and wheel in proper alignment.
- Inspect rim and fork assembly for damage.
- Ensure axle nut and wheel mounting nuts are secure.
- Inspect wheels for excessive side movement or binding when lifted and spun.
- Inspect for flat spots, wear and proper inflation.
- Inspect chain/chain guard for damage, rust, tension and stretch. Adjust if necessary. Lubricate each link (3-in-1 oil or a quality bike lubricant). Check for damage or looseness.
- Adjust shifter/brake cables according to shifter/brake manufacturer's instructions (included with the handcycle).
- Inspect front fork. Keep tight and lubricate (All purpose grease).
- Inspect footrest mounting hardware is tight and footrest secure.
- Inspect footrest straps for wetness and/or damage.
- Inspect seat positioning strap for any signs of wear. Ensure buckle latches. Verify hardware that attaches strap to frame is secure and undamaged. Replace if necessary.
- Inspect upholstery for rips or sagging.
- Ensure that casters are free of debris.

Inspect/Adjust Monthly

- Inspect for bent or broken frame.
- Ensure that casters are free of debris.

Inspect/Adjust Periodically

- Inspect for bent or broken frame.
- Inspect parking brake - Adjust brake shoes to front rim. Check for worn or missing shoes. Check for wax or oil on rim.
- Ensure cable anchor is attached securely to brake arm.
- Ensure internal stopping brakes engages easily.

CAUTION

As with any vehicle, the wheels/casters and tires should be checked periodically for cracks, flat spots and wear, and should be replaced.

- Ensure axle nuts are tight. Wheel should be centered in fork. Keep wheel bearings adjusted and keep spokes tight and wheel in proper alignment.
- Inspect rim and fork assembly for damage.
- Ensure axle nut and wheel mounting nuts are secure.
- Inspect wheels for excessive side movement or binding when lifted and spun.
- Inspect for flat spots, wear and proper inflation.
- Inspect chain/chain guard for damage, rust, tension and stretch. Adjust if necessary. Lubricate each link (3-in-1 oil or a quality bike lubricant). Check for damage or looseness.
- Adjust shifter/brake cables according to shifter/brake manufacturer's instructions (included with the handcycle).
- Inspect front fork. Keep tight and lubricate (All purpose grease).
- Inspect footrest mounting hardware is tight and footrest secure.
- Inspect footrest straps for wetness and/or damage.
- Inspect seat positioning strap for any signs of wear. Ensure buckle latches. Verify hardware that attaches strap to frame is secure and undamaged. Replace if necessary.
- Inspect upholstery for rips or sagging.
- Clean upholstery with light detergent and water.
- Inspect hand grips for looseness. If loose, replace.
- Check that all labels are present and legible. Replace if necessary.
- Ensure that casters are free of debris.

Troubleshooting

VEERS RIGHT	VEERS LEFT	SLUGGISH TURN OR PERFORMANCE	WHEEL FLUTTERS	SQUEAKS AND RATTLES	LOOSENESS IN HANDCYCLE	SOLUTIONS
X	X	X	X			Check tires for correct and equal pressure.
X	X					Check road crown compensator or XLT Gold dampener hardware and adjustment
		X	X	X	X	Check for loose axle nuts.
				X	X	Check spokes and nipples.
		X		X	X	Check chain for proper tension and adjustment.
			X		X	Check that goose neck fittings are secure.

Maintenance

Maintenance Safety Precautions

⚠ WARNING

After any adjustments, repair or service and before use, make sure all attaching hardware is tightened securely - otherwise injury or damage may result.

CAUTION

DO NOT overtighten hardware attaching to the frame. This could cause damage to the frame tubing.

Suggested Maintenance Procedures

1. Before using your handcycle, make sure all nuts and bolts are tight. Check all parts for damage or wear and replace. Check all parts for proper adjustment.
2. Check parking brake cable and shifter adjustment cables for proper adjustment and operation. Refer to Service Procedures on page 46.

3. If equipped, keep quick release axles free of dirt and lint to ensure positive locking and proper operation. Refer to [Installing/Adjusting the Rear Wheel and Quick-Release Axles](#) on page 42.

⚠ WARNING

DO NOT use WD-40®, 3-in-1 oil, or other penetrating lubricants on quick-release axles. Otherwise, binding and/or damage to the handcycle may occur.

4. Clean/oil quick-release axles once a week with a Teflon® lubricant.
5. Keep optional quick release levers on axle tubes free of dirt and lint to ensure positive locking and proper operation.

⚠ WARNING

DO NOT use the handcycle unless it has the proper tire pressure (p.s.i.). DO NOT overinflate the tires. Failure to follow these suggestions may cause the tire to explode and cause bodily harm.

6. Recommended tire pressure is listed on the side wall of the tire. If tire needs replaced, see local bike shop.

CAUTION

As with any vehicle, the wheels and tires should be checked periodically for cracks and wear, and should be replaced.

7. The wheels and tires should be checked periodically for cracks and wear, and should be replaced if damaged.
8. Check chain for slack and readjust. Refer to [Installing/Adjusting Seven Speed Hub Chain](#) on page 54 or [Installing/Adjusting Twenty-Seven Speed Cassette Chain](#) on page 55.
9. Regularly check for loose spokes in the front and rear wheels. If loose, have them aligned at your local bike shop.
10. Check road crown compensator and steering dampner for proper operation. Refer to [Installing/Removing/Adjusting the Road Crown Compensator](#) on page 50 and [Installing/Removing/Adjusting the Steering Dampener - For Top End XLT Gold and Force Only](#) on page 52.
11. Check upholstery for sagging, rips or tears. Refer to [Replacing Seat Upholstery](#) on page 58 and [Replacing Back Upholstery](#) on page 59.
12. Check alignment of front wheel. If it wobbles or takes too much effort to turn by hand, have it aligned at your local bicycle shop.

SECTION 4—INITIAL SETUP

⚠ WARNING

After any adjustments, repair or service and before use, make sure all attaching hardware is tightened securely - otherwise injury or damage may result.

DO NOT operate the handcycle if the hand crank obstructs your view. If the hand crank obstructs your view, adjust the hand crank height before using the handcycle - otherwise injury or damage may occur.

Initial Setup

NOTE: For this procedure, refer to FIGURE 4.1 on page 24 and FIGURE 4.2 on page 25.

NOTE: Invoacare recommends that the following procedures be performed by a qualified technician.

TOOLS REQUIRED:	
Adjustable Wrench (10-12 inches)	1/2-inch Box Wrench
5, 8 and 32 mm Wrench	1/2-inch Socket Wrench
3/16-inch Allen Wrench	Medium Flat Screwdriver
1/4-inch Allen Wrench	Medium Phillips Screwdriver

1. Install and adjust rear wheels ([Installing/Adjusting the Rear Wheel and Quick-Release Axles](#) on page 42 or [Installing the Rear Wheels with Threaded Axles](#) on page 43). Ensure quick-release axles or threaded axles secure wheels to the handcycle.
2. Adjust footrest ([Replacing/Adjusting the Footrest and Leg Guard](#) on page 32) so that there is a slight bend in the knee.
3. Adjust hand crank assembly ([Adjusting Hand Crank](#) on page 34) if unable to see over hand crank or if knees obstruct hand crank rotation.
4. Adjust chain length ([Adjusting Seven Speed Hub Chain](#) on page 55 or [Adjusting Twenty-Seven Speed Cassette Chain](#) on page 56) if crank has been adjusted.
5. If installed, ensure parking brake functions properly ([Adjusting/Replacing the Parking Brake](#) on page 57). Check tension and adjust parking brake cable if necessary.
6. Check brakes to make sure brakes work properly.
7. If back height is adjustable, adjust back height ([Adjusting Back Height - Wide Back Option Only](#) on page 41).
8. Adjust seat position/upholstery ([Adjusting Seat Fore/Aft - All Models Except XLT Gold and Top End Force](#) on page 36, [Adjusting Seat Height - All Models Except XLT Gold and Top End Force](#) on page 38 and/or [Replacing Seat Upholstery](#) on page 58).
9. Adjust the hand crank. Refer to [Adjusting Hand Crank](#) on page 34.
10. Check that all hardware is tight.

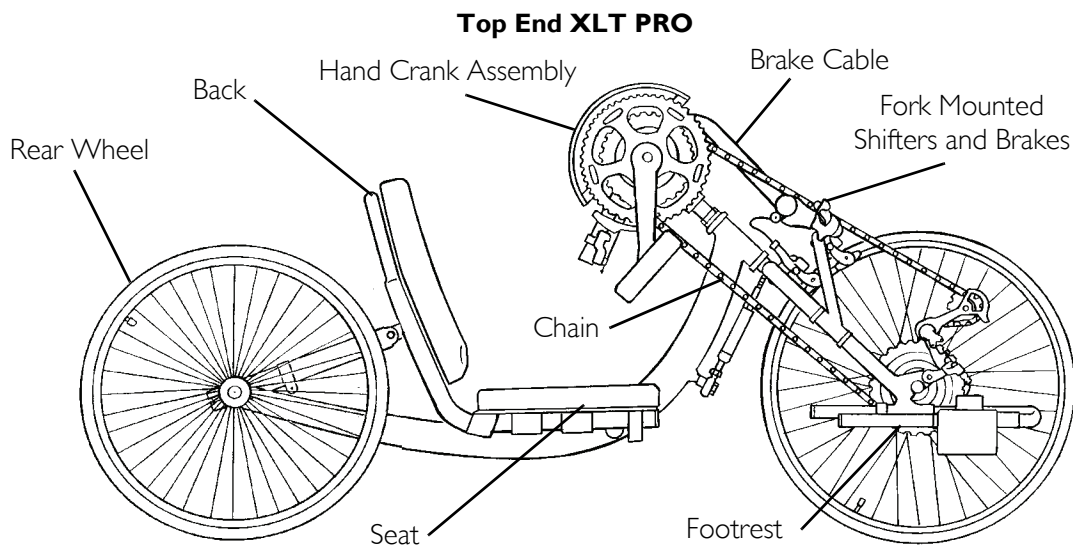
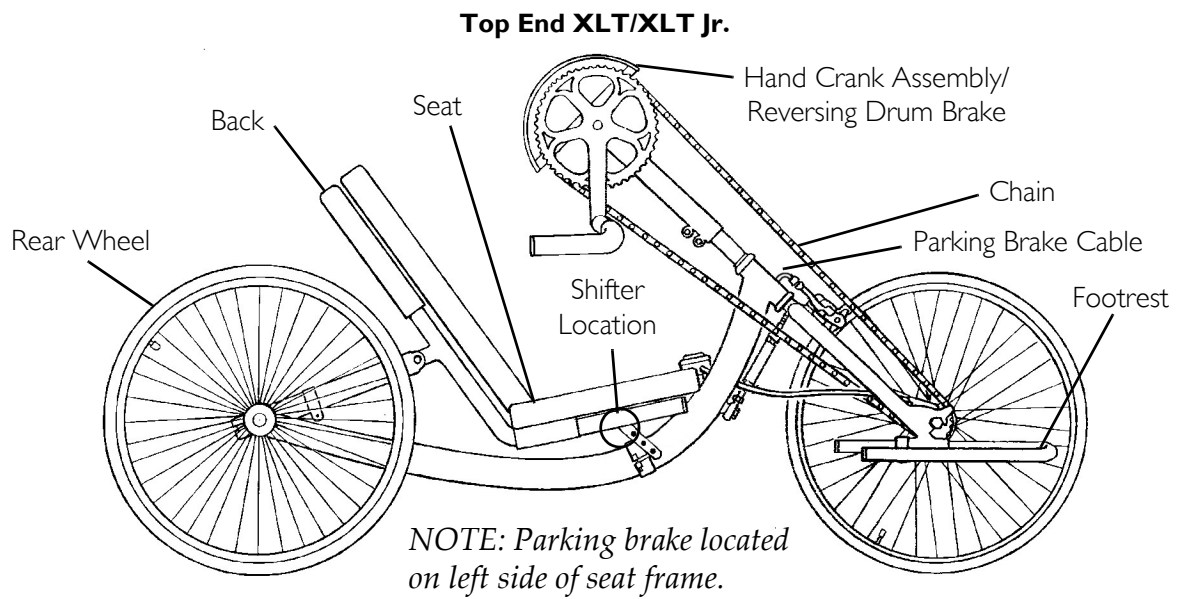

FIGURE 4.1 Initial Setup

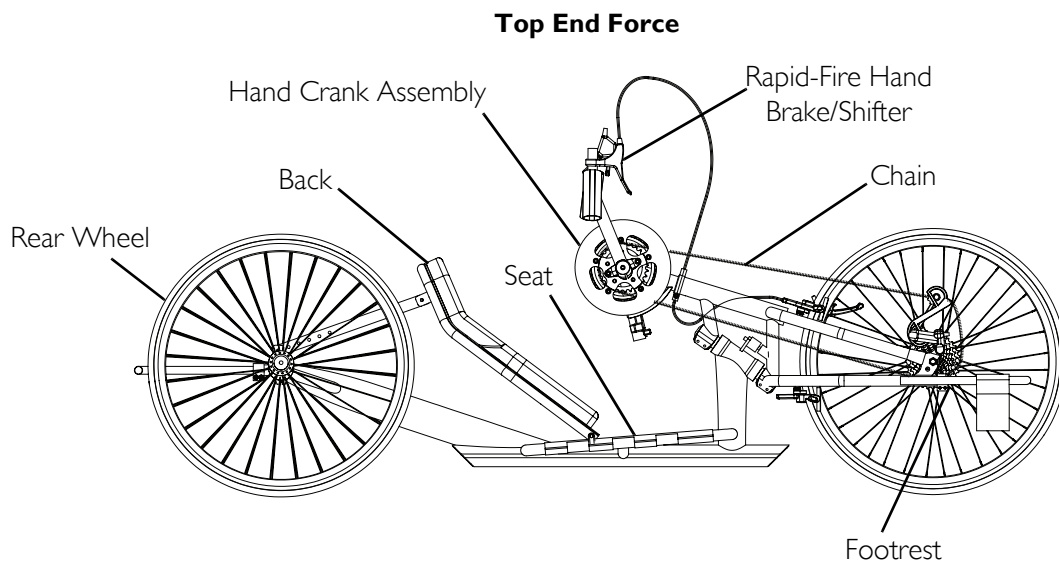
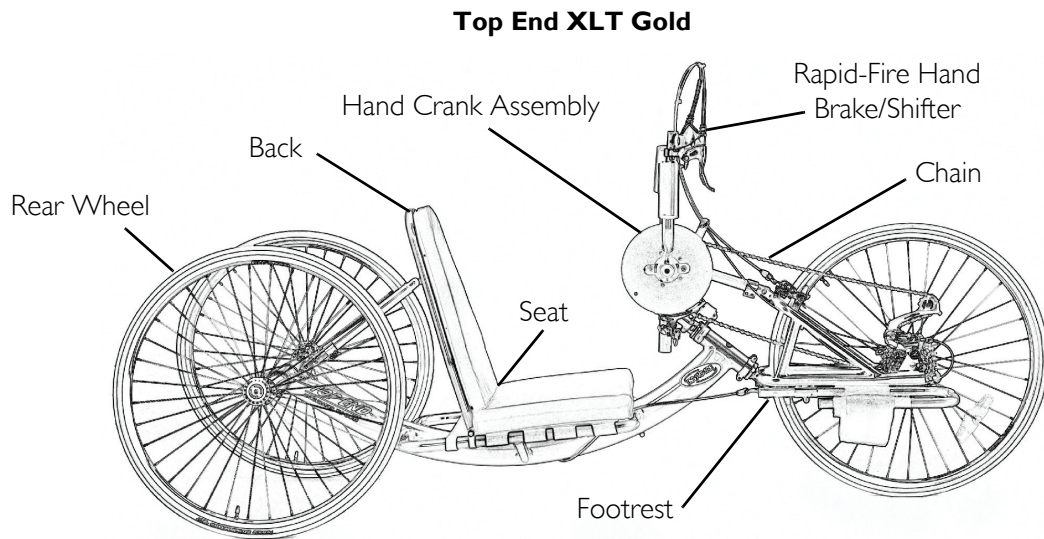

FIGURE 4.2 Initial Setup

SECTION 5—OPERATION

⚠ WARNING

After any adjustments, repair or service and before use, make sure all attaching hardware is tightened securely - otherwise injury or damage may result.

Riding the Handcycle

⚠ WARNING

Before operating the handcycle, review the General Guidelines on page 12 in of this manual.

DO NOT operate the handcycle if the hand crank obstructs your view. If the hand crank obstructs your view, adjust the height before using the handcycle - otherwise injury or damage may occur.

NOTE: For this procedure, refer to FIGURE 5.1 on page 27.

1. Engage the parking brake, if equipped. Refer to Using Parking Brake on page 30.
2. Transfer into the handcycle. Refer to Transferring Into/Out of the Handcycle on page 16.
3. Ensure that the hand crank is not obstructing your view. Refer to Adjusting Hand Crank on page 34.
4. Ensure the footrest is adjusted properly. If necessary, adjust the footrest. Refer to Replacing/Adjusting the Footrest and Leg Guard on page 32.

NOTE: Footrest should be adjusted so that when seated with feet in the footrests, there is a slight bend at the knee.

5. Ensure the seat is adjusted properly. If necessary, adjust the seat. Refer to Adjusting Seat Fore/Aft - All Models Except XLT Gold and Top End Force on page 36 or Adjusting Seat Height - All Models Except XLT Gold and Top End Force on page 38.

NOTE: Seat should be adjusted so that when seated with feet in the footrests, there is a slight bend at the knee and a slight bend at the elbow when the hand crank is furthest away.

6. If installed, release the parking brake. Refer to Using Parking Brake on page 30.
-

⚠ WARNING

At least one hand MUST be on the hand crank assembly at all times. Otherwise, injury or damage may occur.

7. Place at least one hand onto the hand crank pedals.

NOTE: The hand crank assembly is used for propelling and steering of the handcycle.

8. Rotate (pedal) the hand crank forward (toward the front) to propel the handcycle forward.
9. Top End XLT and XLT Jr. Models Only - Rotate (pedal) the hand crank backward (toward the rear) to apply the brake and slow down or stop.

NOTE: Top End XLT shown for clarity.

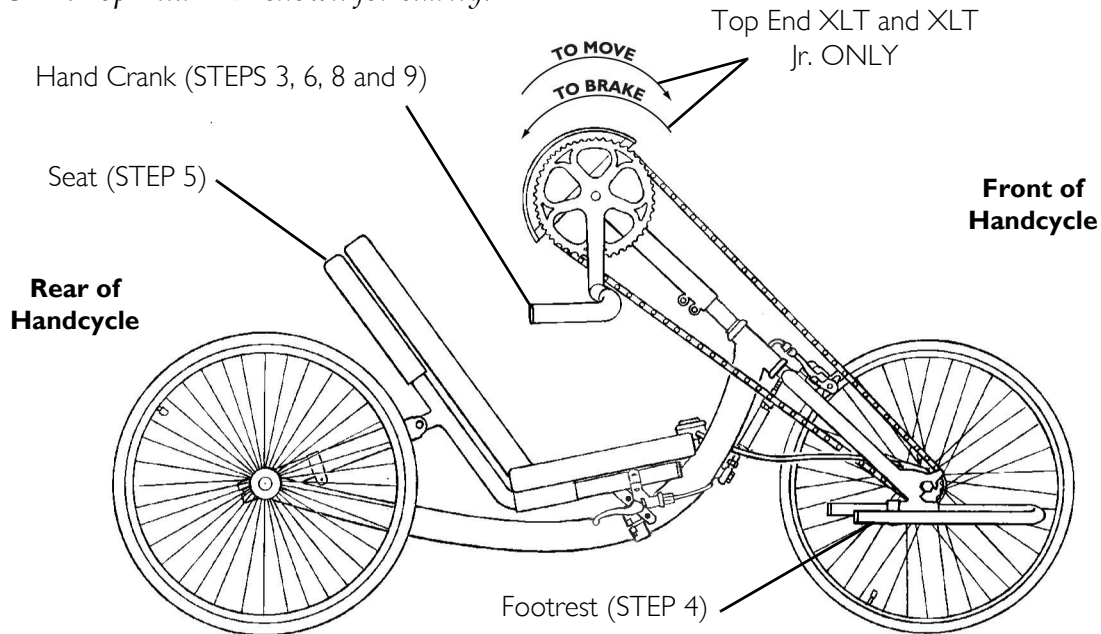

FIGURE 5.1 Riding the Handcycle

Shifting Gears

Seven Speed Hub

NOTE: For this procedure, refer to FIGURE 5.2.

NOTE: This procedure applies to the Top End XLT and XLT Jr. ONLY.

To shift gears while moving, hold onto the hand crank assembly with one hand, continue pedaling, but ease pressure on the pedals and select the gear required with the other hand. When the Top End XLT is stationary, simply select gear required.

1. Perform one of the following:
 - Upshift - Push the shifting lever towards the indicator and release. Repeat until the desired gear is achieved.
 - Downshift - Push shifting lever down and away from the indicator. Repeat until the desired gear is achieved.

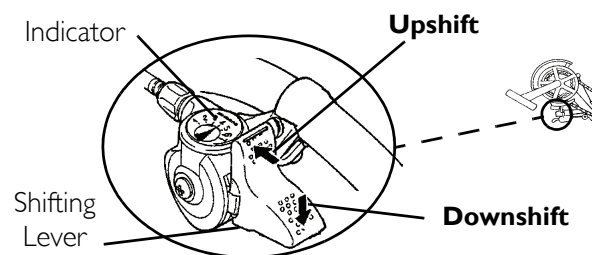

FIGURE 5.2 Shifting Gears - Seven Speed Hub

Hands-On Rapid Fire Shifter/Brake System: Twenty-seven Speeds

NOTE: For this procedure, refer to FIGURE 5.3 on page 29.

NOTE: This procedure applies to the Top End XLT Pro, XLT Gold, and Force ONLY.

To shift gears, you **MUST** turn the crank forward with the chain under some tension while the bike is moving. **DO NOT** attempt to shift gears while bike is stationary.

There are two shifters installed on the handcycle. The right shifter operates the nine gears on the lower derailleur and the manual shifter operates the three chain rings on the upper derailleur. Nine gears X three chain rings = Twenty-seven speeds.

Shifting the chain on the lower derailleur towards the centerline of the handcycle is for climbing/accelerating (easier cranking) (lever A) and is called a downshift. Moving the chain on the lower derailleur out or away from the centerline of the handcycle is for speed (harder cranking) (lever B) and is called an upshift.

Refer to the chart below for an explanation and use of the upper derailleur chain rings in combination with the lower derailleur gears:

LOWER DERAILLEUR GEARS (RIGHT SHIFTER)	UPPER DERAILLEUR CHAIN RINGS (MANUAL SHIFTER)	USE
1 - 9	Smallest	Climbing Hills or Strong Headwinds
10 - 18	Medium	Flats or Gradual Rolling Terrain
19 - 27	Largest	Descending Hills or Strong Tailwinds

Each shifter has a large lever (brake handle), a medium lever (shifter lever "A") and a small lever (shifter lever "B"). The right and left shifters work in an opposite manner.

CAUTION

DO NOT press both shifter levers down at the same time. Doing so may damage the shifter and will void the warranty. The gears **WILL NOT** shift when both levers are pressed simultaneously.

DO NOT use excessive force. This may damage the shifter and void the warranty.

Lower Derailleur (Right Side Shifter)

- Shifting from Harder Gears to Easier Gears (Downshift) - Push shift lever "B" and release. Repeat until the desired gear is achieved.
- Shifting from Easier Gears to Harder Gears (Upshift) - Pull shift lever "A" and release. Repeat until the desired gear is achieved.

Upper Derailleur (Manual Shifter)

- Shifting from Easier or Smaller Chainring to Harder or Larger Chainring (Upshift) - Push lever up until chain runs smoothly over the chain ring teeth while the handcycle is moving.
- Shifting from Harder or Larger Chainring to Easier or Smaller Chainring (Downshift) - Push lever down until chain runs smoothly over the chain ring teeth while the handcycle is moving.

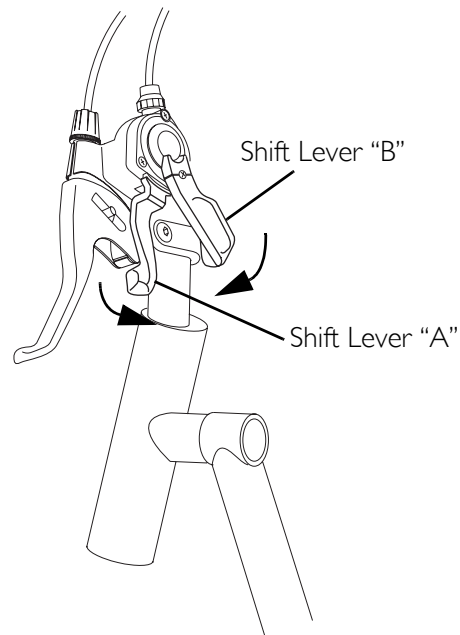

FIGURE 5.3 Shifting Gears - Hands-On Rapid Fire Shifter/Brake System: Twenty-seven Speeds - Hands-On Rapid Fire Shifter/Brake System: Twenty-seven Speeds

Backing-Up

Use the rear wheels (i.e. like a manual handcycle) to backup. When backing up, keep the front wheel straight. The weight of the hand crank may engage the reversing drum brakes (Top End XLT and XLT jr. models ONLY) while backing up. Lift the pedals up to avoid this problem.

CAUTION

If backing up in the XLT PRO, XLT Gold and Force models, take care not to tangle the cables.

Braking

Top End XLT Handcycles have either internal gearing (7 speeds) or external gearing (24 or 27 speeds). Internal geared handcycles (7 speeds) are equipped with reversing drum brakes. External geared handcycles (24 or 27 speeds) have hand brakes.

Reversing Drum Brakes

NOTE: Top End XLT and XLT Jr. with the seven speed hub have reversing drum brakes.

Use the brakes intermittently on your handcycle to bring it to a complete stop. Apply by pedaling in reverse.

Hand Brakes/Hands-On Brakes

⚠ WARNING

The twenty-seven speed cassette on the Top End XLT Pro, XLT Gold and Top End Force models use the hand brake as the primary brake. Reverse pedaling **WILL NOT** stop the bike.

Handcycles equipped with Hand Brakes - In situations where caution is advised (heavy traffic, intersections, etc.) hands should be kept in the "ready" position to prepare for braking.

NOTE: For this procedure, refer to FIGURE 5.4.

1. Squeeze brake handle(s) as needed to slow or come to a complete stop.
2. Release when desired speed is achieved.

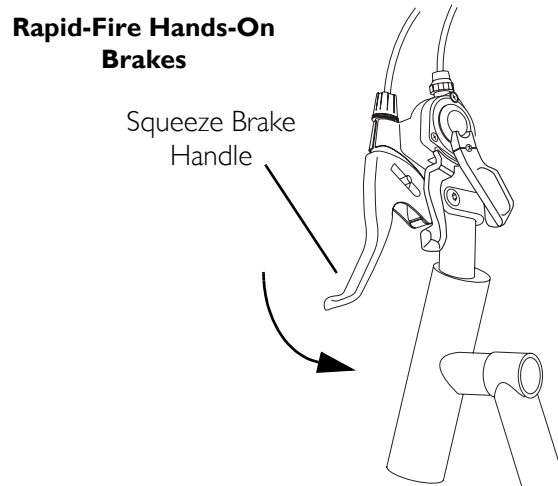

FIGURE 5.4 Braking - Hand Brakes/Hands-On Brakes

Using Parking Brake

⚠ WARNING

Before attempting to transfer in or out of the handcycle, every precaution should be taken to reduce the gap distance. Position the handcycle on level ground and as close as possible to the object you are transferring into or out of.

The object you are transferring into or out of **MUST** also be secured before attempting any transfer.

The parking brake of the handcycle **MUST** be engaged before attempting any transfer.

NOTE: For this procedure, refer to FIGURE 5.5.

- To Engage the Parking Brake - Squeeze the handle and push the ratchet lever and lift until the handle locks in place.

- To Disengage the Parking Brake - Squeeze and release the ratchet button.

Parking Brake Location

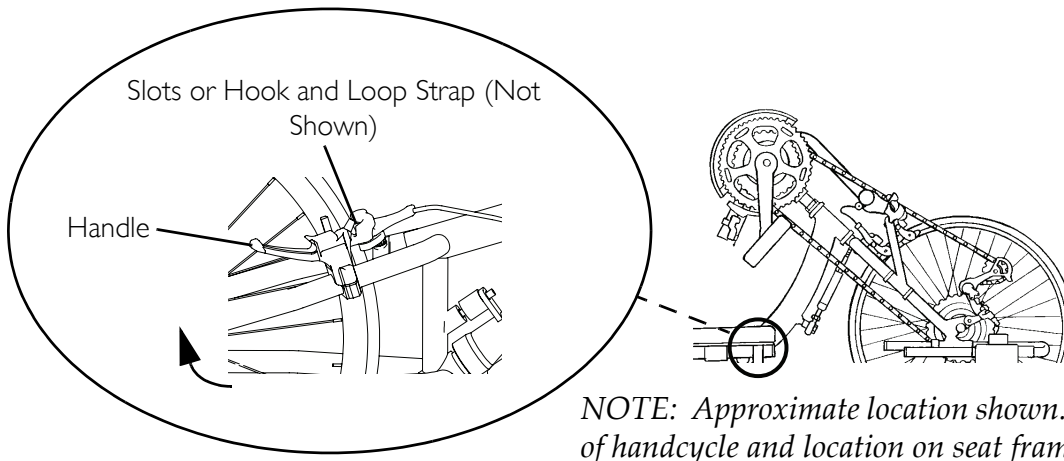

NOTE: Approximate location shown. Actual side of handcycle and location on seat frame may vary.

FIGURE 5.5 Using Parking Brake

Steering/Cornering

⚠ WARNING

DO NOT attempt to corner the handcycle at high speeds. This could result in a fall causing injury and/or damage to the handcycle.

NOTE: For this procedure, refer to FIGURE 5.6.

To steer the handcycle, use the hand crank to direct the front fork and wheel assembly in the direction you intend to go (straight, right, or left).

- Steering can be done while rotating the hand crank (pedaling) or coasting.
- When cornering, it is recommended that you slow the handcycle, stop pedaling, steer the handcycle and coast through the turn. Hands should be up in the crank cycle (at approximately between the 11 and 2 o'clock position).

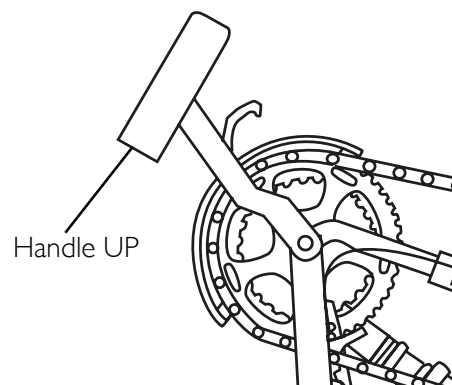

FIGURE 5.6 Steering/Cornering

SECTION 6—RIDING POSITION

⚠ WARNING

After any adjustments, repair or service and before use, make sure all attaching hardware is tightened securely - otherwise injury or damage may result.

Replacing/Adjusting the Footrest and Leg Guard

NOTE: For this procedure, refer to FIGURE 6.1.

NOTE: If replacing footrest or leg guard, take note of current position.

Replacing/Adjusting Footrest

1. Remove the hex bolt and locknut that secure the footrest to the fork.
2. If replacing footrest perform the following:
 - A. Remove existing footrest from clamp.
 - B. Insert new footrest into clamp.
3. Slide footrest to desired position.
4. Reinstall hex bolt and locknut. Tighten securely.
5. Repeat STEPS 1-5 for the opposite footrest, if necessary.

Footrest Replacement/Adjustment

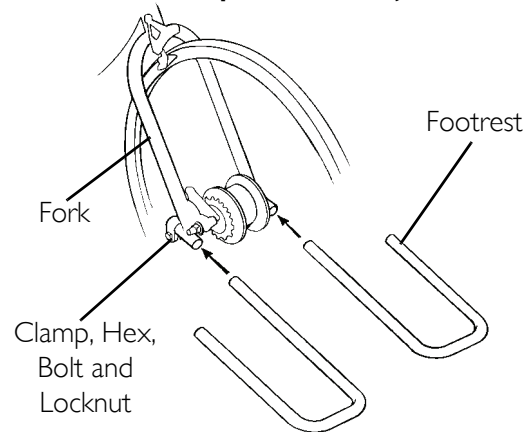

Leg Guard Replacement/Adjustment

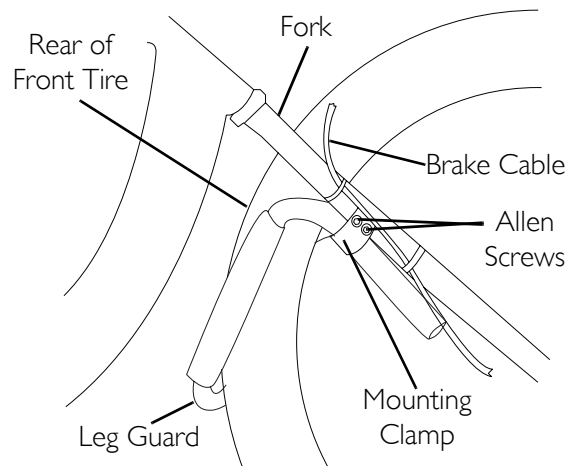

Replacing/Adjusting Leg Guard

NOTE: This procedure is for Top End XLT, XLT Jr., and XLT Pro ONLY.

1. Loosen the two allen screws on each mounting clamp.
2. If replacing leg guard, perform the following:
3. Remove existing leg guard from clamps.
4. Insert new leg guard into clamps.
5. Position each mounting clamp onto the fork under the brake cable.

NOTE: The leg guard should surround, but not touch, the rear of the front tire.

6. Adjust leg guard to desired position.
7. Tighten the two allen screws on each mounting clamp securely.

FIGURE 6.1 Replacing/Adjusting the Footrest and Leg Guard

Using/Replacing Footrest Strap

⚠ WARNING

Footrest straps **MUST** be inspected before each use. Exposure to moisture (i.e.- wet weather or puddles) will damage fastening strips. Footrest strap will not hold feet securely in footrest if fastening strips are damaged. **DO NOT** operate handcycle if footrest straps are wet or damaged, otherwise severe injury may occur.

ALWAYS wear shoes and securely strap feet in using straps provided. Severe injury may occur if feet are not secured while the handcycle is in motion.

Using Footrest Strap

NOTE: For this procedure, refer to FIGURE 6.2.

1. Place feet in footrests.
2. Secure feet to footrest strap using small fastening straps.

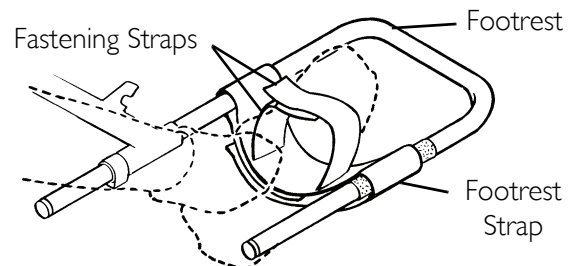

FIGURE 6.2 Using Footrest Strap

Replacing Footrest Strap

NOTE: For this procedure, refer to FIGURE 6.3.

1. Pull apart fastening straps securing existing footrest strap to footrest.

NOTE: The small fastening straps should face up.

2. Wrap end of footrest strap over and around the inner footrest tube and firmly connect the hook and loop portions of the footrest strap (Detail "A").
3. Wrap end of footrest strap over and around the outer footrest tube and under the inner footrest tube and firmly connect the hook and loop portions of the footrest strap (Details "A" and "B").
4. Ensure the footrest strap is firmly attached to the loop fastening strip on the outer footrest tube.

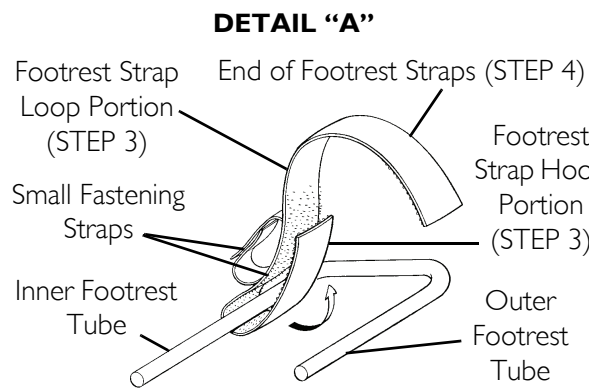

DETAIL "B"

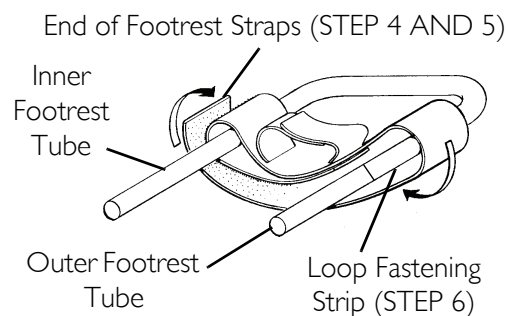

FIGURE 6.3 Replacing Footrest Strap

Adjusting Hand Crank

⚠ WARNING

DO NOT operate the handcycle if the hand crank obstructs your view. If the hand crank obstructs your view, adjust the height before using the handcycle - otherwise injury or damage may occur.

Adjusting Hand Crank Height - All Models Except Top End XLT Gold

NOTE: For this procedure, refer to FIGURE 6.4.

1. Loosen, but **DO NOT** remove the two set screws securing the hand crank to the fork stem.
2. Move the hand crank assembly up or down on the fork stem until you are comfortable with the position for operational purposes.

*NOTE: The hand crank should be positioned so that when the hand is toward the front of the handcycle, the arm is slightly bent. The arm should **NEVER** be fully extended (locked) at any point while cranking.*

3. Tighten the hex nut to secure the hand crank in the desired position.
4. Tighten the chain if necessary. Refer to [Adjusting Twenty-Seven Speed Cassette Chain](#) on page 56.

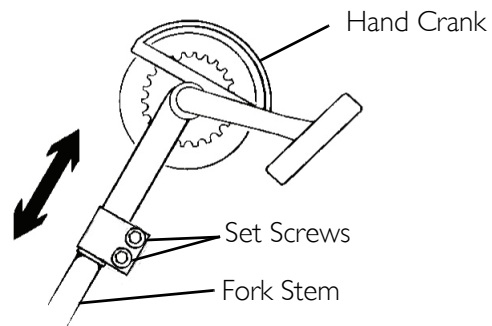

FIGURE 6.4 Adjusting Hand Crank Height - All Models Except Top End XLT Gold

Adjusting Top End XLT Gold Hand Crank

NOTE: For this procedure, refer to FIGURE 6.5.

Adjusting Hand Crank Height

1. Loosen, but DO NOT remove the hex nut securing the hand crank to the fork stem.
2. Loosen, but DO NOT remove the two set screws for the upper clamp.
3. Move the hand crank assembly up or down in the fork neck until you are comfortable with the position for operational purposes.

NOTE: The hand crank should be positioned so that when the hand is toward the front of the handcycle, the arm is slightly bent. The arm should NEVER be fully extended (locked) at any point while cranking.

4. Tighten the hex nut to secure the hand crank in the desired position.
5. Tighten the two set screws on the upper clamp.
6. Tighten the chain if necessary. Refer to [Adjusting Seven Speed Hub Chain](#) on page 55 or [Adjusting Twenty-Seven Speed Cassette Chain](#) on page 56.

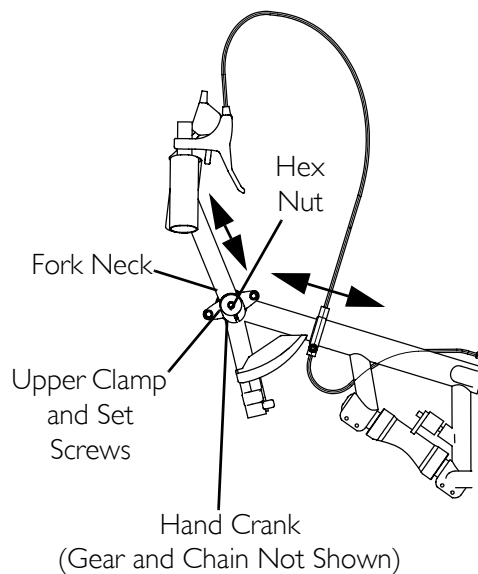

FIGURE 6.5 Adjusting Top End XLT Gold Hand Crank

Adjusting Seat Fore/Aft - All Models Except XLT Gold and Top End Force

NOTE: For this procedure, refer to FIGURE 6.6.

NOTE: Seat should be adjusted so that when seated with feet in the footrests, there is a slight bend at the knee and a slight bend at the elbow when the hand crank is furthest away.

1. If installed, activate parking brake.
2. Loosen, but DO NOT remove the four rear socket screws that secure the rear seat frame to the handcycle frame.
3. Loosen, but DO NOT remove the two front socket screws that secure the front of the seat frame to the handcycle frame.

NOTE: There are socket screws on the right and left side of the handcycle.

4. Loosen, but DO NOT remove the hex bolts and locknuts that secure the two seat angle adjustment clamps to the rear seat supports.

NOTE: There is one clamp on the right and left side of the handcycle.

5. Perform one of the following:
 - Moving the Seat Rearward - While lifting up on the back support tubes, push the seat rearward to the desired position.
 - Moving the Seat Forward - While pushing down on the back support tubes, pull the seat forward to the desired position.
6. Tighten the six socket screws that secure the seat frame to the handcycle frame securely.
7. Tighten the hex bolts and locknuts that secure the two seat angle adjustment clamps to the rear seat supports securely.

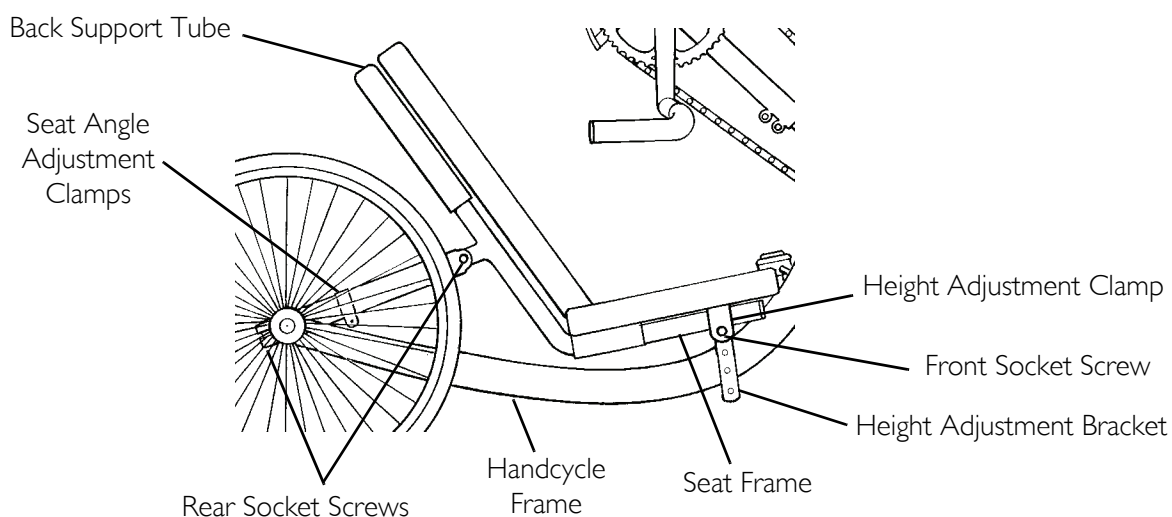

FIGURE 6.6 Adjusting Seat Fore/Aft - All Models Except XLT Gold and Top End Force

Adjusting Seat Fore/Aft - XLT Gold and Top End Force Only

NOTE: For this procedure, refer to FIGURE 6.7.

NOTE: Seat should be adjusted so that when seated with feet in the footrests, there is a slight bend at the knee and a slight bend at the elbow when the hand pedal is furthest away.

1. Remove the seat upholstery. Refer to Replacing Seat Upholstery on page 58.
2. Loosen, but DO NOT remove the two mounting bolts and locknuts securing the two back clamps to the seat rails.
3. Slide back clamps for (forward) or aft (rearward) along the seat rails to desired seat position.
4. Securely tighten the two mounting bolts and locknuts securing the two back clamps to the seat rails.
5. Reinstall the seat upholstery. Refer to Replacing Seat Upholstery on page 58.
6. If necessary adjust the back angle.

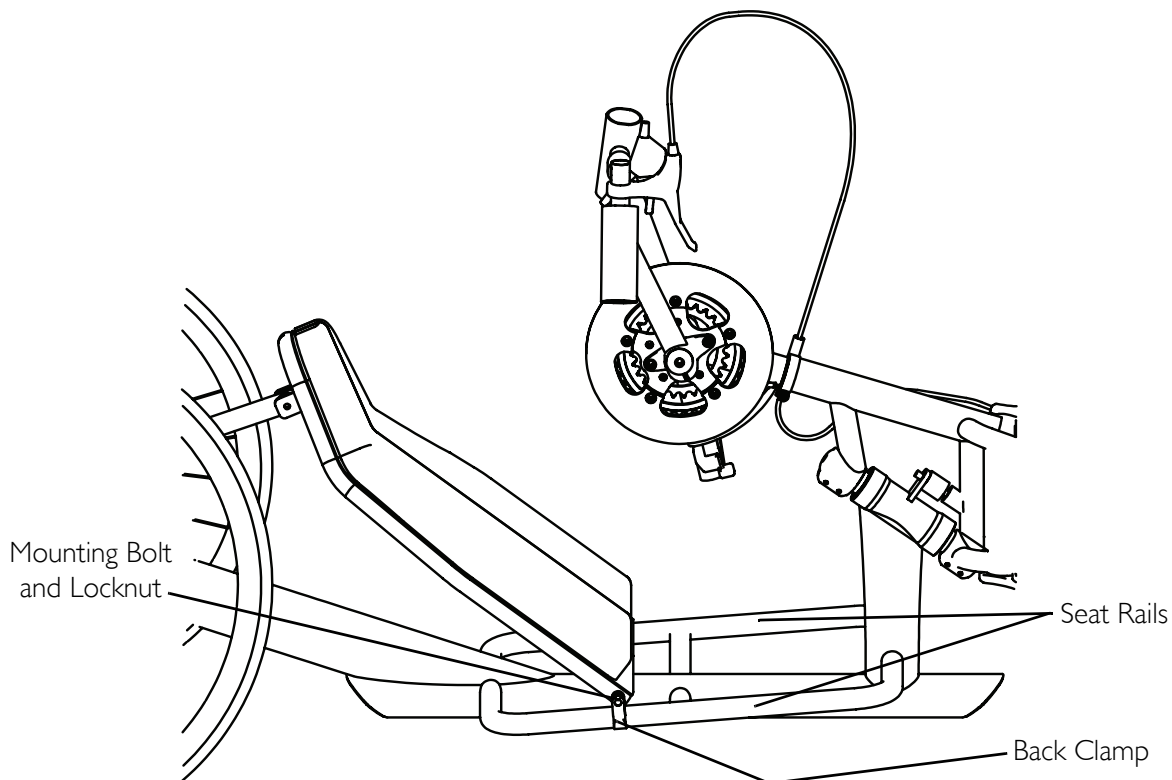

FIGURE 6.7 Adjusting Seat Fore/Aft - XLT Gold and Top End Force Only

Adjusting Seat Height - All Models Except XLT Gold and Top End Force

NOTE: For this procedure, refer to FIGURE 6.8.

1. Loosen, but **DO NOT** remove the four socket screws securing the rear of the seat to the handcycle frame.
2. Remove the two socket screws securing the front of the seat frame to the handcycle frame.
3. Align the seat height adjustment clamp with the desired height adjustment hole in the seat height adjustment bracket.
4. Install the two socket screws to secure the front of the seat frame to the handcycle frame.

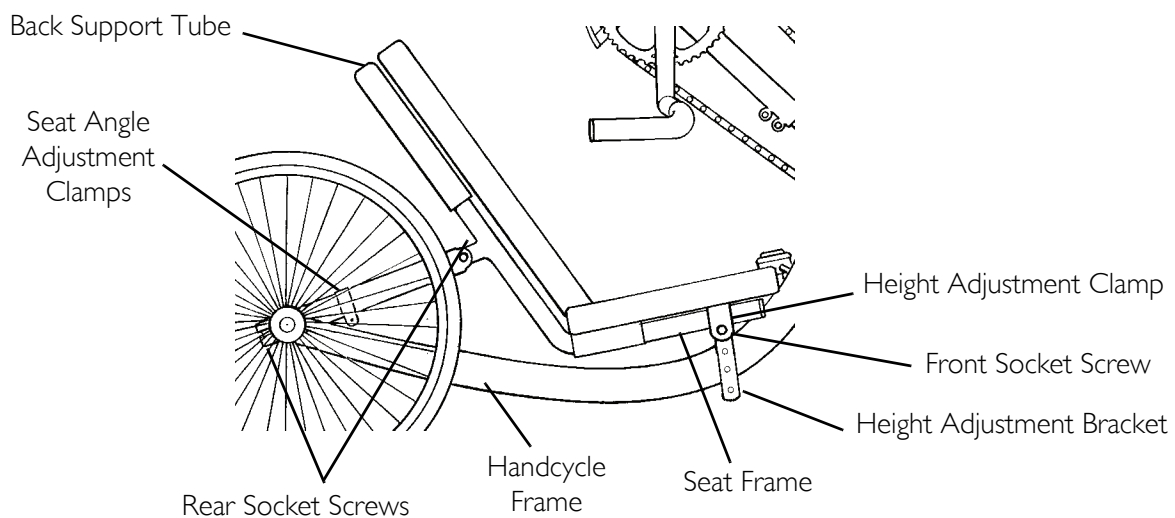

FIGURE 6.8 Adjusting Seat Height - All Models Except XLT Gold and Top End Force

Adjusting Back Angle - All Models Except XLT Gold and Top End Force

NOTE: For this procedure, refer to FIGURE 6.9.

1. If installed activate parking brake.
2. Loosen, but DO NOT remove the four rear socket screws that secure the seat frame to the handcycle frame.

NOTE: There are two socket screws on the right and left side of the handcycle.

3. Loosen, but DO NOT remove the hex bolts and locknuts that secure the two seat angle adjustment clamps to the rear seat supports.

NOTE: There is one clamp on the right and left side of the handcycle.

4. Perform one of the following:
 - Increasing Back Angle - While lifting up on the back support tubes, pull the seat upward to the desired position.
 - Decreasing Back Angle - While pushing down on the back support tubes, push the seat down to the desired position.
5. Tighten the four socket screws that secure the seat frame to the handcycle frame securely.
6. Tighten the hex bolts and locknuts that secure the two seat angle adjustment clamps to the rear seat supports securely.

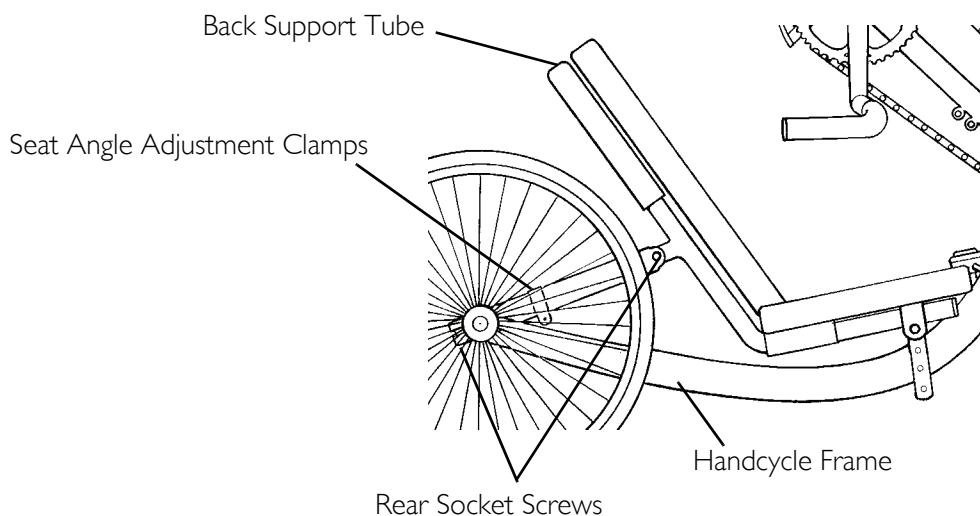
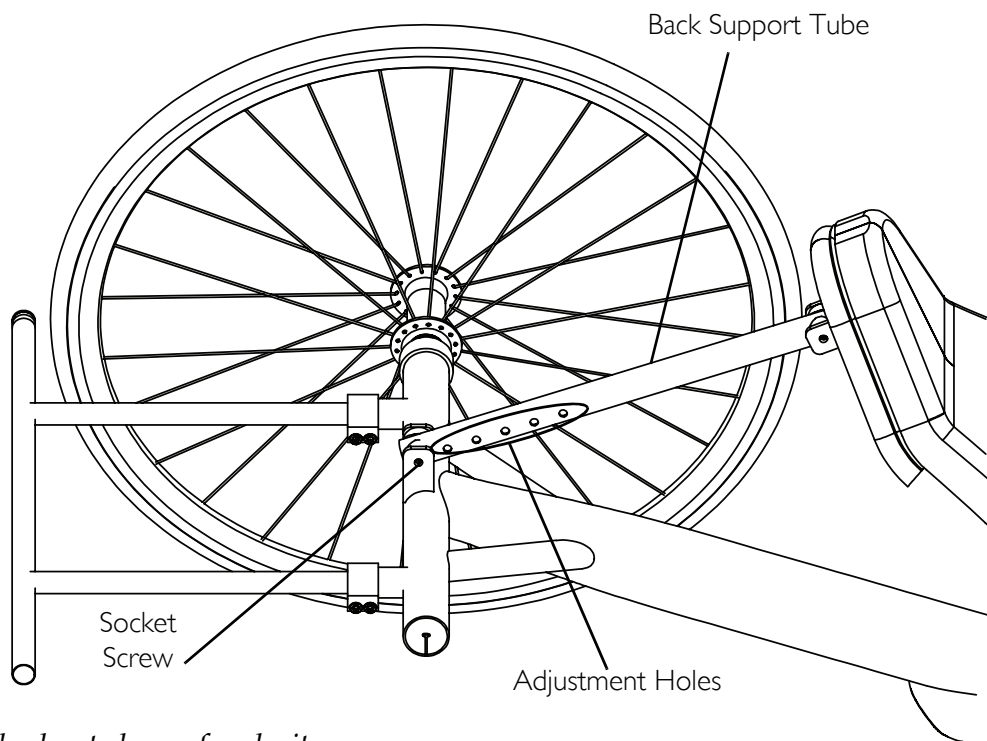

FIGURE 6.9 Adjusting Back Angle - All Models Except XLT Gold and Top End Force

Adjusting Back Angle - XLT Gold

NOTE: For this procedure, refer to FIGURE 6.10.

1. Loosen, but DO NOT remove, the two socket screws located in the seat angle adjustment clamp.
2. Perform one of the following:
 - Increasing Back Angle - While pushing down on the back support tube, push the back down to the desired position.
 - Decreasing Back Angle - While lifting up on the back support tube, pull the back upward to the desired position.
3. Securely tighten the two socket screws located in the seat angle adjustment clamp.



NOTE: Wheel not shown for clarity.

FIGURE 6.10 Adjusting Back Angle - XLT Gold

Adjusting Back Height - Wide Back Option Only

NOTE: For this procedure, refer to FIGURE 6.11.

NOTE: This procedure applies to Top End XLT models with wide back option only.

1. Remove the back upholstery from the handcycle. Refer to [Replacing Back Upholstery](#) on page 59.

⚠ WARNING

Push pin MUST protrude through hole in back cane.

Ensure that both back cane inserts are at the same height before reassembling the chair.

2. Press the push pin on the back cane insert tube in and adjust the back height to one of three heights depending on original back height.
3. Reinstall the back upholstery onto the handcycle. Refer to [Replacing Back Upholstery](#) on page 59.

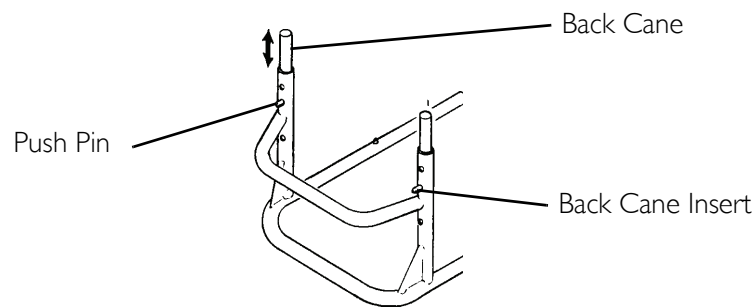

FIGURE 6.11 Adjusting Back Height - Wide Back Option Only

SECTION 7—WHEELS

⚠ WARNING

After any adjustments, repair or service and before use, make sure all attaching hardware is tightened securely - otherwise injury or damage may result.

Installing/Adjusting the Rear Wheel and Quick-Release Axles

NOTE: For this procedure, refer to FIGURE 7.1.

1. Make sure that the axle receiver hex nut is securely tightened before installing the rear wheels.
2. Depress detent pin in the quick-release axle and slide axle through the axle receiver.
3. Release detent pin ensuring that the locking pins are fully released.

NOTE: Locking pins MUST protrude past the end of the axle receiver to fully release. Any excessive play MUST also be eliminated.

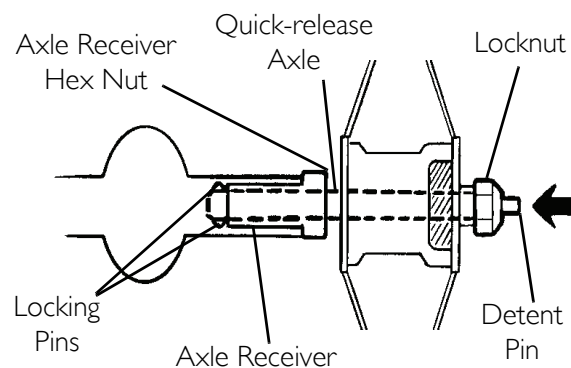

FIGURE 7.1 Installing/Adjusting the Rear Wheel and Quick-Release Axles

4. Increase or decrease end play by adjusting the locknut on the end of the quick-release axle.

⚠ WARNING

Make sure detent pin is fully released before operating the handcycle.

Keep locking pins clean.

5. Reinstall rear wheel on the handcycle.
6. Tilt handcycle onto either rear wheel and spin raised wheel. It should spin freely with no excessive drag.
7. Repeat procedure for opposite rear wheel.

NOTE: If drag to either side occurs, repeat the procedure until the handcycle rolls correctly.

Installing the Rear Wheels with Threaded Axles

NOTE: For this procedure, refer to FIGURE 7.2.

1. Apply a small amount of grease onto the axle.
2. Insert the axle into the axle mounting hole on the handcycle frame.
3. Securely tighten the axle to the frame.

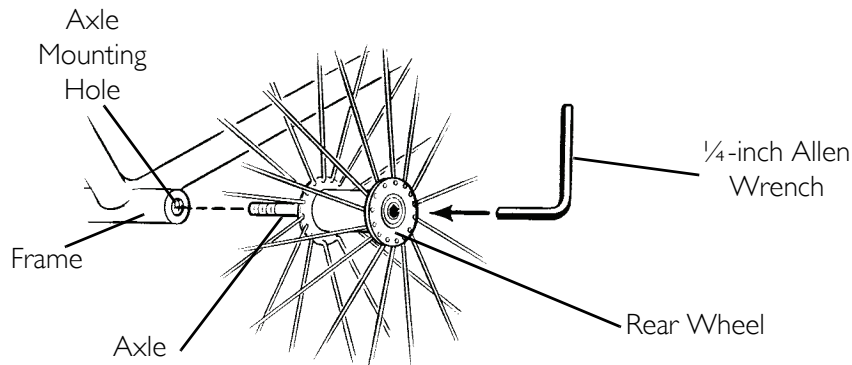

FIGURE 7.2 Installing the Rear Wheels with Threaded Axles

Replacing Tire/Tube and Tuning/Replacement of Spokes

NOTE: Invacare recommends that these procedures be performed by a qualified technician.

Tire Pressure

⚠ WARNING

DO NOT use the handcycle unless it has the proper tire pressure (p.s.i.). **DO NOT** overinflate the tires. Failure to follow these suggestions may cause the tire to explode and cause bodily harm. Tire p.s.i. is printed on the tire wall.

Determining/Adjusting Toe In/Toe Out

NOTE: For this procedure, refer to FIGURE 7.3.

Determining Toe In/Toe Out

1. Inflate all pneumatic tires to recommended tire pressures (listed on the sidewall of the tire).
2. Measure the distance between the center lines at the rear and front of the rear wheels at approximately 12 inches from the ground/floor.

NOTE: For optimum accuracy, perform STEP 2 with the handcycle occupied.

NOTE: Step 2 may be performed with using alignment gauge (available as an option for the handcycle). Refer to [Using the Alignment Gauge](#) on page 74.

3. Determine the difference between the two measurements. If the difference between the two measurements is greater than 1/8-inch (for maximum rollability), one of two conditions exists:

- If the back centerline measurement of the rear wheels is smaller than the front centerline measurement of the rear wheels, a toe-out condition exists.
- If the back centerline measurement of the rear wheels is LARGER than the front centerline measurement of the rear wheels, a toe-in condition exists.

4. If the difference between the measurements is greater than 1/8-inch, correct the toe-in/toe-out condition. Refer to [Adjusting Toe In/Toe Out](#) on page 45.

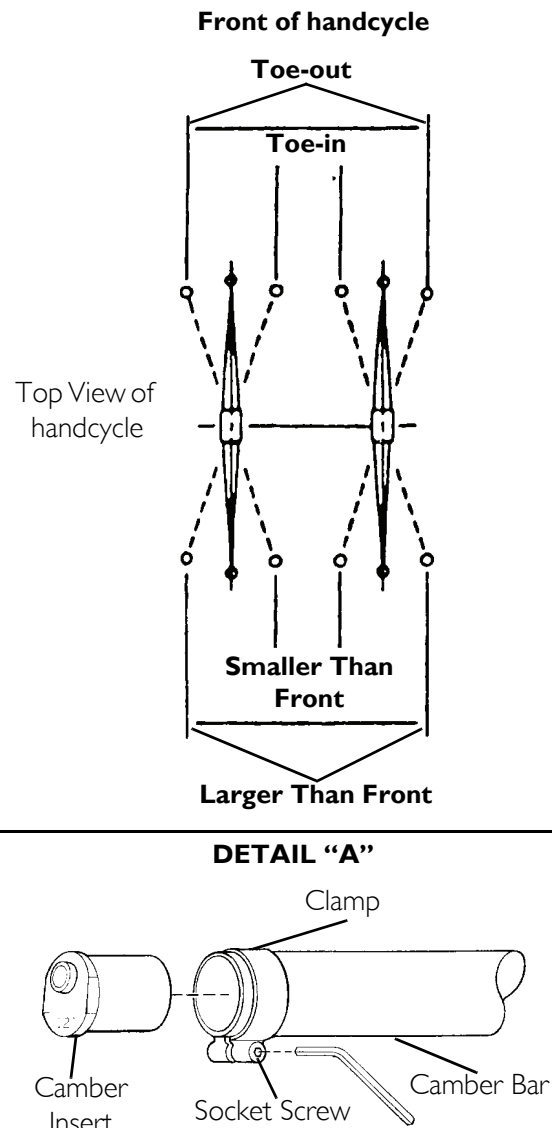

FIGURE 7.3 Determining/Adjusting Toe In/Toe Out

Adjusting Toe In/Toe Out

1. Loosen, but DO NOT remove the socket screws and clamps that secure camber inserts to the camber bar (Detail "A").
2. Slowly rotate the camber insert until the rear wheels are approximately in a straight line.
3. Securely tighten the socket screws and clamps that secure the camber inserts to the camber bar.
4. Measure the distance between the center lines at the rear and front of the rear wheels at approximately 12 inches from the ground/floor. Refer to Determining Toe In/Toe Out on page 44.
5. Repeat STEPS 1-4 until the toe in/toe out measurement is less than 1/8-inch (for maximum rollability).

Replacing Camber Inserts

NOTE: For this procedure, refer to FIGURE 7.4.

1. Loosen, but DO NOT remove the socket screws and clamps that secure the camber inserts to the camber bar.
2. Remove the existing camber insert from the camber bar.
3. Install the new camber insert into the camber bar.
4. Adjust the toe in/toe out of the handcycle. Refer to Determining/Adjusting Toe In/Toe Out on page 44.

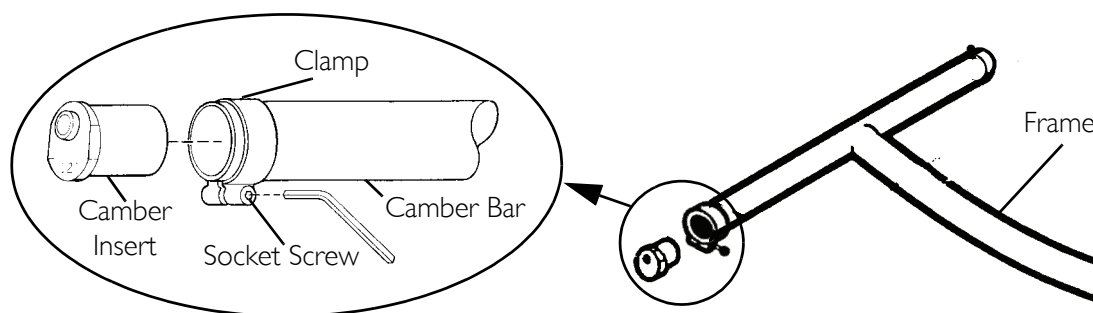

FIGURE 7.4 - Replacing Camber Inserts

SECTION 8—SERVICE PROCEDURES

⚠ WARNING

After any adjustments, repair or service and before use, make sure all attaching hardware is tightened securely - otherwise injury or damage may result.

Replacing the Fork/Crank Assembly

NOTE: For this procedure, refer to FIGURE 8.1 on page 48.

NOTE: Invacare recommends that the following procedure be performed by a qualified technician.

1. Note the position of the crank handles.
2. Loosen, but DO NOT remove the two socket screws that secure the crank handles to the existing fork.
3. Slide the crank handles down towards the front wheel.
4. Remove the chain from the crank handles.
5. Remove the crank handles from the existing fork.
6. Remove the socket nut on the back of the existing fork that secures the brake assembly.
7. Note brake assembly hardware position and remove the brake assembly from the existing fork.
8. Remove the road crown compensator or steering dampener from the existing fork. Refer to Removing Road Crown Compensator on page 51 or Removing Steering Dampener on page 52.
9. Loosen, but DO NOT remove the socket screw that secures the shifting lever to the seat frame.
10. Remove the hex bolt and locknut that secure the brake arm to the brake arm clamp.
11. Remove the brake arm clamp from the existing fork.
12. Loosen, but DO NOT remove the two cap nuts that secure the front wheel to the existing fork.
13. Remove the front wheel from the existing fork.
14. Lay the chain flat.

NOTE: Laying the chain flat will prevent kinks in the chain.

15. Remove the two hex bolts, locknuts and clamps that secure the footrests to the existing fork.
16. Note the position of the footrests and remove the footrests from the existing fork.
17. Remove the two top nuts that secure the existing fork to the frame.
18. Note the o-ring and bearing position and remove the existing fork from the frame.

19. Slide the bottom bearing onto the new fork. Refer to FIGURE 8.1 for correct orientation.
20. Slide the new fork into the frame.
21. Position the o-ring and bearing on the new fork. Refer to FIGURE 8.1 for correct orientation.
22. Install the two nuts onto the new fork and tighten securely. Refer to FIGURE 8.1 for correct orientation.
23. Position the footrest clamps on the new frame.
24. Install the footrests onto the new fork to the position noted in STEP 17 and secure with the two hex bolts and locknuts.
25. Position the chain around the hub of the front wheel.
26. Install the front wheel onto the new fork.

NOTE: Make sure the washer and the non-turn washer are on the outside of the new fork.

27. Line up the projecting ends of the non-turn washer with the slot in the new fork.
28. Repeat STEPS 27-28 until the projecting ends of the non-turn washer line up with the slot in the new fork.
29. Torque the two cap nuts 260-390 in-lbs.
30. Install the brake arm clamp onto the new fork.
31. Secure the brake arm to the brake arm clamp with the hex bolt and locknut. Torque to 22-26 inch-pounds.
32. Reinstall the shifting lever onto the seat frame and secure with the socket screw.
33. Install the road crown compensator or steering dampener onto the new fork. Refer to [Installing Road Crown Compensator](#) on page 50 or [Installing Steering Dampener](#) on page 52.
34. Install the brake assembly onto the new fork. Refer to the hardware position noted in STEP 8 and tighten securely with the socket nut.
35. Slide the crank handles onto the new fork.

NOTE: Make sure the sprocket on the crank handles is in line with the sprocket on the front wheel.

36. Reinstall the chain onto the crank handle sprocket.
37. Move the crank handle to the position determined in STEP 1 and tighten the two socket screws securely.

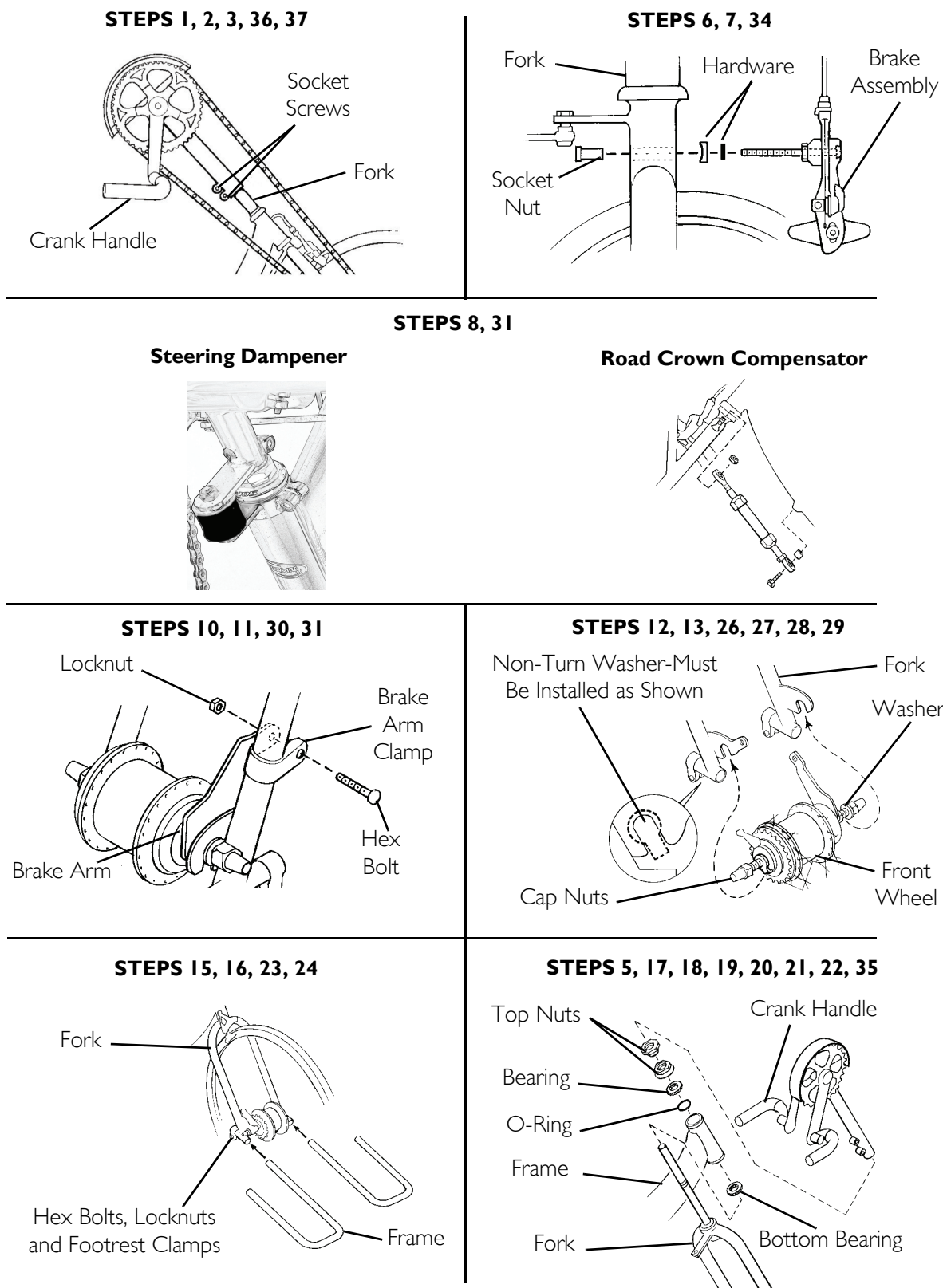

FIGURE 8.1 Replacing the Fork/Crank Assembly

Replacing the Crank Arms - XLT Gold, XLT PRO and Top End Force

NOTE: For this procedure, refer to FIGURE 8.2 on page 50.

NOTE: Right and left determined from as if seated on the handcycle.

Replacing the Left Side Crank Arms

1. Remove the two socket screws from the existing crank arm clamp.
2. Remove socket screw and cap from the spindle.
3. Remove the existing crank arm from the spindle.
4. Position the new crank arm onto the spindle so that the new crank arm is evenly aligned with the right side crank arm.
5. Re install the socket screw and cap from the spindle. **DO NOT** over tighten.
6. Using the two socket screws, secure the new crank arm clamp to the spindle. Securely tighten.

Replacing the Right Side Crank Arms

1. Remove the two mounting bolts and locknuts securing the chain ring disk to the tabs of the existing crank arm.
2. Remove the two socket screws from the existing crank arm clamp.
3. Remove socket screw and cap from the spindle.
4. Remove the existing crank arm from the spindle.
5. Position the new crank arm onto the spindle.
6. Using the two mounting bolts and locknuts, secure the tabs of the new crank arm to the chain ring disk.
7. Ensure the new crank arm is evenly aligned with the left side crank arm.
8. Re install the socket screw and cap from the spindle. **DO NOT** over tighten.
9. Using the two socket screws, secure the new crank arm clamp to the spindle. Securely tighten.

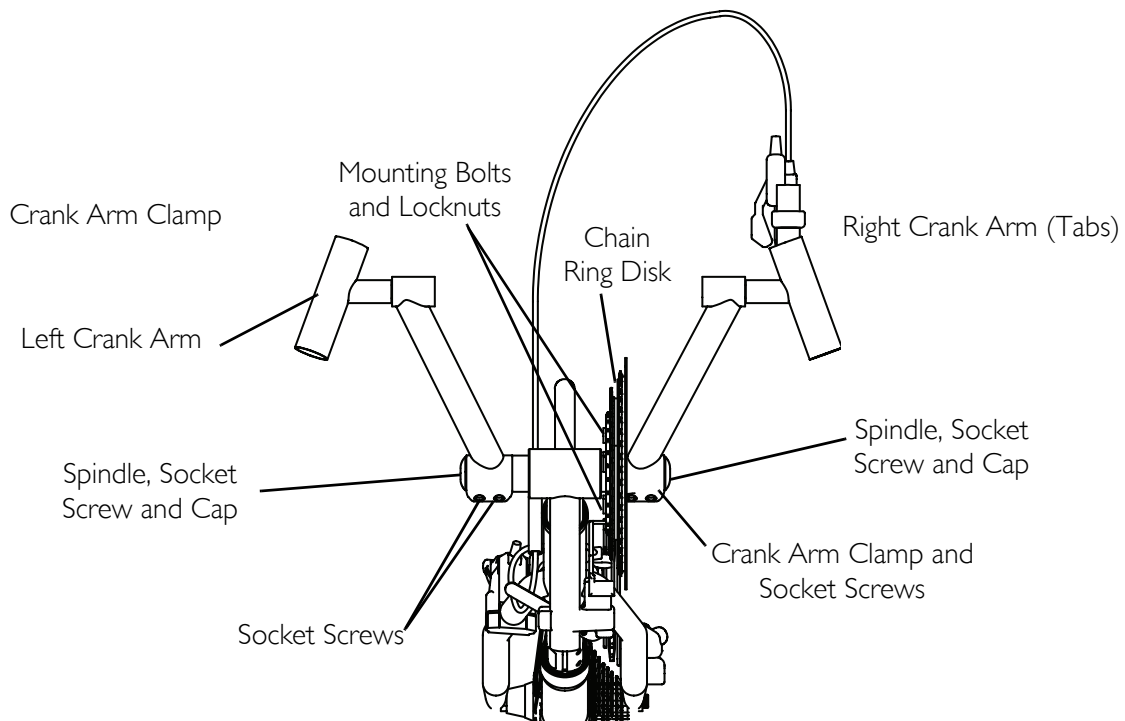

FIGURE 8.2 Replacing the Crank Arms - XLT Gold, XLT PRO and Top End Force

Installing/Removing/Adjusting the Road Crown Compensator

NOTE: For this procedure, refer to FIGURE 8.3 on page 51.

NOTE: The road crown compensator is designed to stabilize the handcycle during transfers and while riding and is not intended to keep the handcycle straight when pedaling but to keep the handcycle from leaning excessively to one side or another.

Installing Road Crown Compensator

1. Position the bolt through the frame end of the road crown compensator.
2. Position the spacer on the bolt.
3. Install the bolt with spacer and road crown compensator into the mounting hole on the frame.
4. Rotate the fork to ensure the front wheel is pointing directly forward.
5. Position the fork end of the road crown compensator on the fork bolt.

NOTE: If necessary, lengthen or shorten the road crown compensator to position the fork end onto the fork bolt. Refer to Adjusting Road Crown Compensator on page 51.

6. Secure the road crown compensator to the fork bolt with the locknut. Tighten securely.

Removing Road Crown Compensator

1. Remove the locknut securing the fork end of the road crown compensator to the fork bolt.
2. Remove the fork end of the road crown compensator from the fork bolt.
3. Remove the bolt and spacer securing the frame end of the road crown compensator to the frame.

Adjusting Road Crown Compensator

NOTE: This adjustment is made for handcycling on crowned roads or in heavy winds.

1. Rotate the fork end of the road crown compensator to adjust the length. Clockwise - shortens the road crown compensator and pulls the front wheel to the left. Counterclockwise - lengthens the road crown compensator and pushes the front wheel to the right.

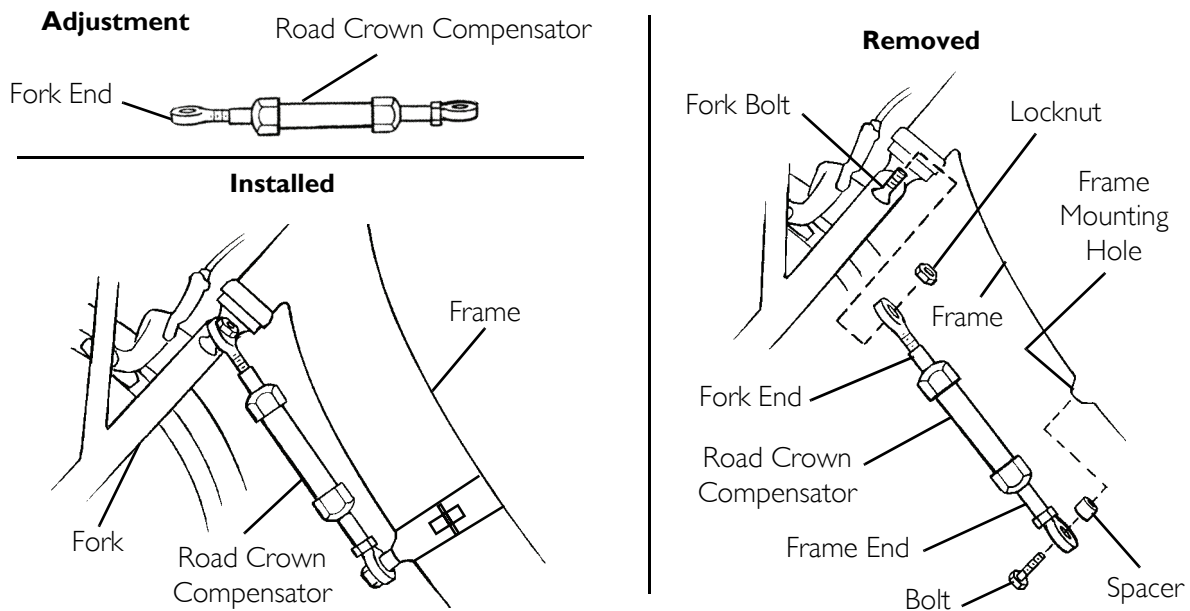

FIGURE 8.3 Installing/Removing/Adjusting the Road Crown Compensator

Installing/Removing/Adjusting the Steering Dampener - For Top End XLT Gold and Force Only

NOTE: For this procedure, refer to FIGURE 8.4 on page 53.

NOTE: The steering dampener is designed to stabilize the handcycle during transfers and while riding and is not intended to keep the handcycle straight when pedaling but to keep the handcycle from leaning excessively to one side or another.

Installing Steering Dampener

1. Using a locknut, secure the upper threaded post of the steering dampener to the crank assembly tab.
2. While inserting the lower threaded post into the tab, position the dampener clamp around the handcycle frame.
3. Using two socket screws, loosely secure the dampener clamp to the handcycle frame.
4. Using a locknut, secure the steering dampener to the dampener clamp.
5. Ensuring the front wheel and dampener clamp are inline with the handcycle frame, securely tighten the two socket screws securing the dampener clamp to the handcycle frame.
6. Test drive handcycle, if handcycle pulls to the left or right adjust the steering dampener. Refer to [Adjusting Steering Dampener](#) on page 52.

Removing Steering Dampener

1. Remove the locknut securing the steering dampener to the dampener clamp.
2. Remove the two socket screws securing the dampener clamp to the handcycle frame.
3. Remove the dampener clamp from the handcycle frame and the lower threaded post of the steering dampener
4. Remove the locknut securing the upper threaded post of the steering dampener to the crank assembly tab.
5. Remove the steering dampener from the crank assembly.

Adjusting Steering Dampener

1. Loosen, but DO NOT remove, the two socket screws securing the dampener clamp to the handcycle frame.
2. Ensuring the front wheel and dampener clamp are inline with the handcycle frame, securely tighten the two socket screws securing the dampener clamp to the handcycle frame.
3. Test drive handcycle, if handcycle pulls to the left or right repeat STEPS 1-3 until handcycle drives straight.

**Top End
XLT Gold
ONLY****Top End
Force
ONLY**

FIGURE 8.4 Installing/Removing/Adjusting the Steering Dampener - For Top End XLT Gold and Force Only

Installing Seven Speed Shifter Cable

NOTE: For this procedure, refer to FIGURE 8.5.

NOTE: This procedure applies to the Top End XLT only.

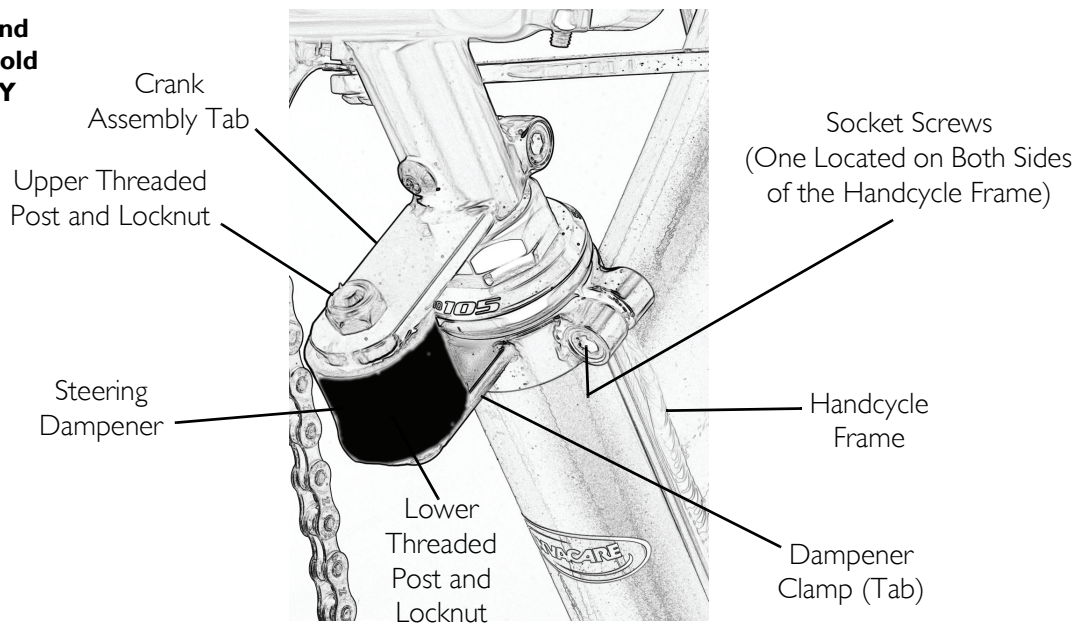
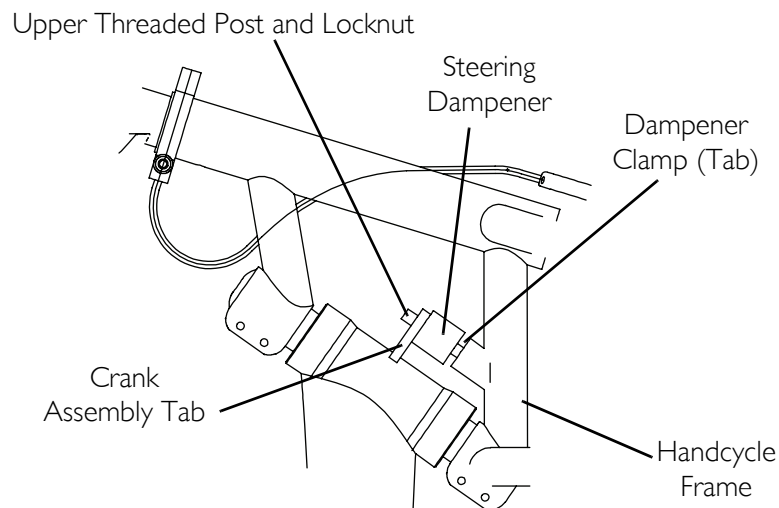
NOTE: The seven speed Shifter Cable runs from the right side of the front frame to its mounting position on the hand crank assembly.

1. Run the cable from the right-side of the fork assembly to mounting position on the left side just below the hand crank assembly.
2. Attach the seven speed shifter to the hand crank assembly extension.
3. Secure with hardware provided.

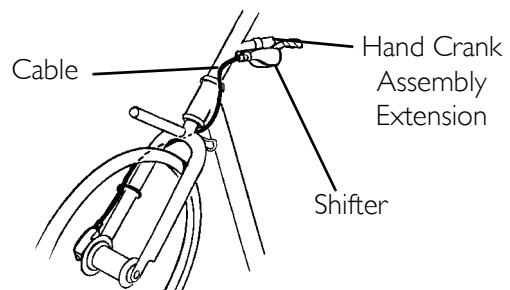

FIGURE 8.5 Installing Seven Speed Shifter Cable

Adjusting/Replacing Seven Speed Shifter

Handcycles with seven speed shifters are equipped with SHIMANO hubs. If equipped with a SHIMANO hub, it **MUST** be serviced and adjusted by a qualified technician.

NOTE: QUALIFIED TECHNICIANS ONLY - Contact Invacare, 1-800-532-8677 for complete SHIMANO hub instructions.

It is recommended that you take your handcycle to a qualified technician for any shifter adjustment.

Installing/Adjusting Seven Speed Hub Chain

Seven Speed Hub Chain Installation

⚠ WARNING

Chain MUST be tight. If the chain is noisy, loosen. After chain is assembled, start in first gear and on straightaway.

NOTE: For this procedure, refer to FIGURE 8.6 on page 54.

1. Spread the chain out flat and run it over the bottom chain tensioner upwards to the hand crank sprocket assembly.
2. Position chain over the hand crank sprocket assembly.

NOTE: It may be necessary to turn the hand crank in a clockwise motion to position the chain on the sprocket.

3. Run the chain over the top chain tensioner.
4. Position the chain around the wheel sprocket and back up towards the bottom chain tensioner.
5. Place chain over the top of the bottom chain tensioner.
6. Attach the chain together using the master link (with clip) provided.

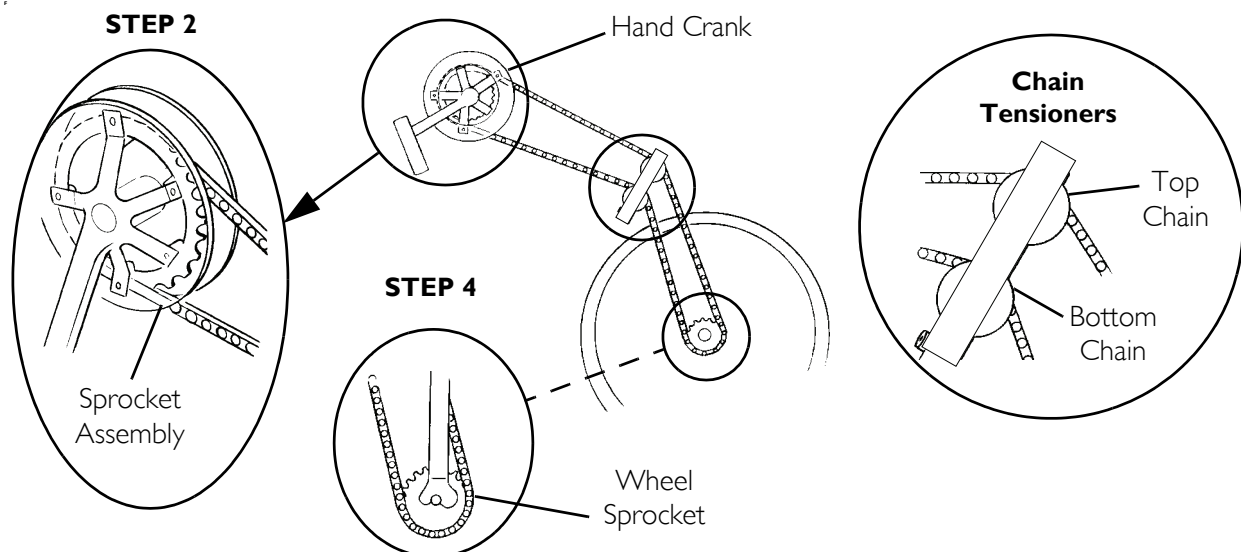

FIGURE 8.6 Seven Speed Hub Chain Installation

Adjusting Seven Speed Hub Chain

⚠ WARNING

Chain MUST be tight. If the chain is noisy, loosen. After chain is assembled, start in first gear and on straightaway.

NOTE: For this procedure, refer to FIGURE 8.7 on page 55.

NOTE: This procedure applies to the Top End XLT and Top End XLT Jr. only.

1. Ensure the hand crank is adjusted to the proper height. Refer to Adjusting Hand Crank on page 34.

NOTE: Repositioning of the hand crank assembly loosens or tightens the chain in an up/down position.

2. Loosen the hex screw securing the adjustable chain idler.
3. Adjust the tautness of the chain by moving the adjustable chain idler in or out as shown in FIGURE 8.7.
4. Tighten the hex screw to secure the adjustable chain idler in place.

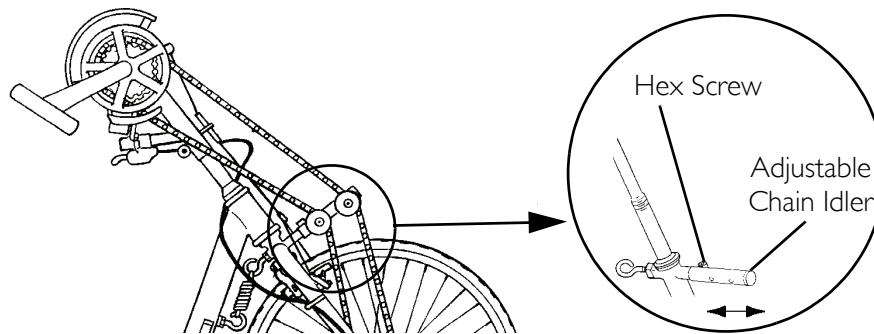

FIGURE 8.7 Adjusting Seven Speed Hub Chain

Installing/Adjusting Twenty-Seven Speed Cassette Chain

Installing Twenty-Seven Speed Cassette Chain

NOTE: For this procedure, refer to FIGURE 8.8 on page 56.

1. Spread the chain out flat and run it around the chain ring on the crank and the sprocket on the hub.

NOTE: It may be necessary to turn the hand crank in a clockwise motion to position the chain on the small sprocket.

2. Ensure that crank assembly is loosened and movable.
3. Lift up on the chain derailleur and thread the chain under the derailleur.
4. Thread the chain around the wheel sprocket.

5. Run the chain around the bottom of the wheel sprocket and back up towards the hand crank sprocket.
6. Attach the chain together using the master link (w/clip) provided.
7. To tension chain, refer to Replacing the Fork/Crank Assembly on page 46.

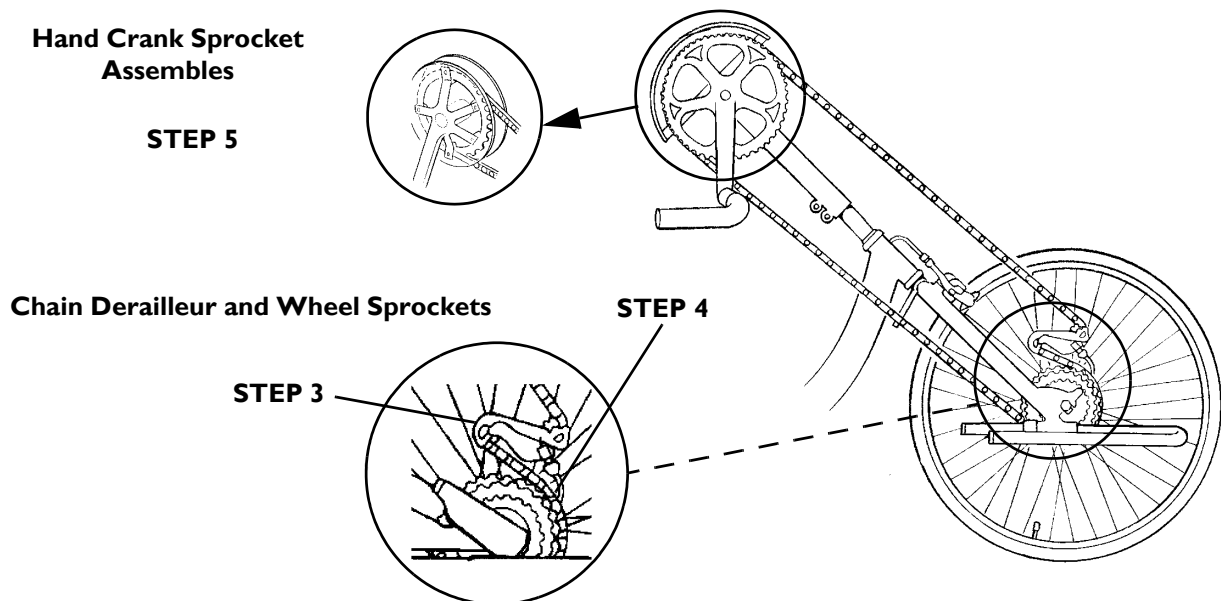

FIGURE 8.8 Installing Twenty-Seven Speed Cassette Chain

Adjusting Twenty-Seven Speed Cassette Chain

NOTE: For this procedure, refer to FIGURE 8.9.

1. Loosen, but **DO NOT** remove the clamp that secure the crank handles to the fork.
2. Slide the crank handles up and/or down until the proper tension on the chain is achieved.

NOTE: The proper chain tension will be approximately ½-inch of chain slack.

*NOTE: If crank is in desired position but chain tension is not correct, links **MUST** be added to or removed from the chain to correct the tension. This should be performed by a qualified technician.*

3. Tighten the clamp that secure the crank handles to the fork securely.

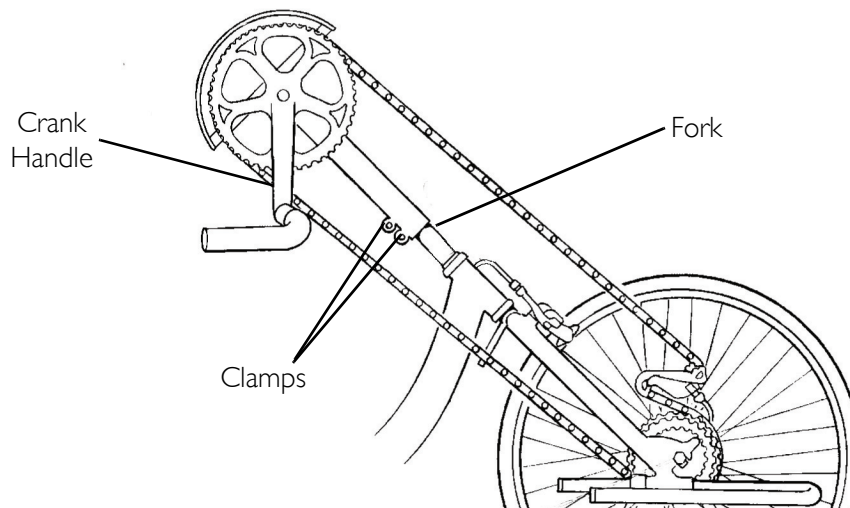

FIGURE 8.9 Adjusting Twenty-Seven Speed Cassette Chain

Adjusting/Replacing the Parking Brake

⚠ WARNING

Before using your handcycle, inspect the parking brake for proper operation.

NOTE: For this procedure, refer to FIGURE 8.10.

Adjusting the Parking Brake

Cable

1. Loosen the hex nut and turn the adjuster barrel clockwise (tighten) or counterclockwise (loosen) to adjust the cable. Retighten hex nut.

Brake Pads

1. Adjust the brake pad assembly so that when the parking brake is engaged the brake pads rest solely on the rim of the wheel.

Replacing the Parking Brake

Brake Pads

1. Remove the mounting nuts and replace brake pads.
2. Secure with existing hardware and adjust.

Parking Brake

⚠ WARNING

Replacement of the parking brake **MUST** be performed by a qualified technician.

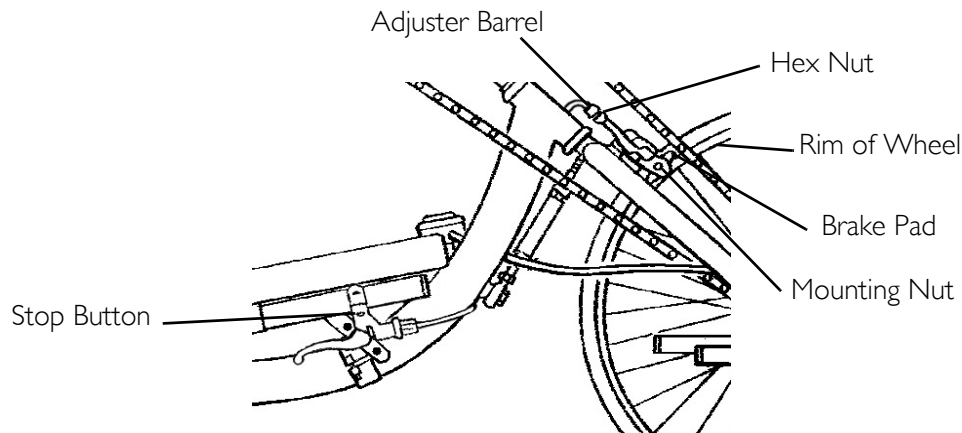

FIGURE 8.10 Adjusting/Replacing the Parking Brake

Replacing Seat Upholstery

⚠ WARNING

Upholstery **MUST** be inspected before each use. Exposure to moisture (i.e. - wet weather or puddles) will damage fastening straps/flaps/strips. **DO NOT** operate handcycle if upholstery is wet or damaged, otherwise severe injury may occur.

NOTE: For this procedure, refer to FIGURE 8.11.

1. Remove seat cushion and back upholstery from chair.
2. Unlatch the four fastening flaps that secure the seat upholstery to the seat frame.
3. Remove the existing seat upholstery.
4. Install the new seat upholstery making sure that the three fastening flaps that are in close proximity to one another are to the rear of the seat frame.
5. Secure the four fastening flaps together.
6. Reinstall back upholstery and seat cushion onto chair.

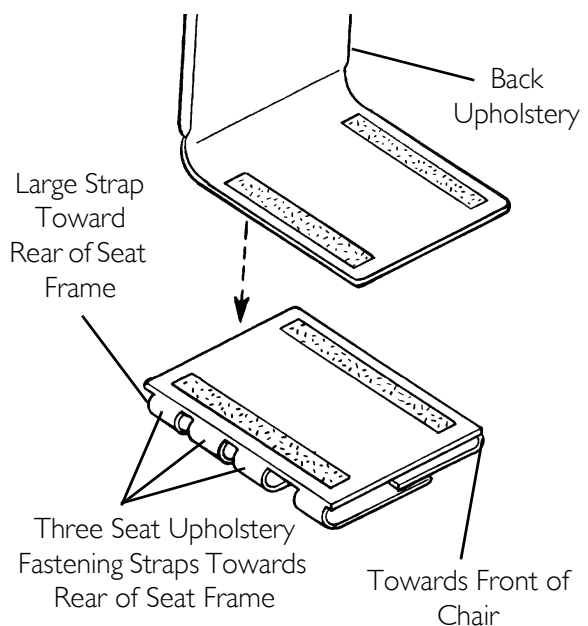

FIGURE 8.11 Replacing Seat Upholstery

Replacing Back Upholstery

⚠ WARNING

Upholstery **MUST** be inspected before each use. Exposure to moisture (i.e. - wet weather or puddles) will damage fastening straps/flaps/strips. **DO NOT** operate handcycle if upholstery is wet or damaged, otherwise severe injury may occur.

Replacing Wide Back Upholstery

NOTE: For this procedure, refer to FIGURE 8.12.

1. Unlatch the two fastening flaps that secure the bottom of existing back upholstery to the back canes.
2. Unlatch the top of the existing back upholstery.
3. Lift up on the existing back upholstery and remove from the handcycle.
4. Install the new back upholstery onto the handcycle.
5. Securely latch the fastening flaps on the bottom of the new back upholstery to the back canes.

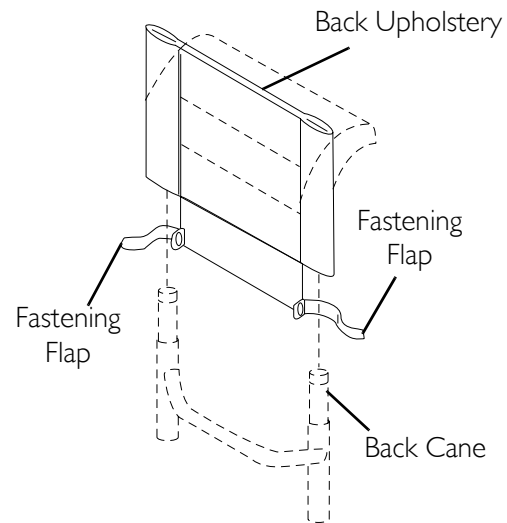

FIGURE 8.12 Replacing Wide Back Upholstery

Replacing Narrow Back Upholstery

NOTE: For this procedure, refer to FIGURE 8.13.

NOTE: Pull the back cushion off the back frame.

1. Align the fastening strips on the back frame with the fastening strips on the new back cushion.
1. Press the back cushion firmly against the back frame to secure.

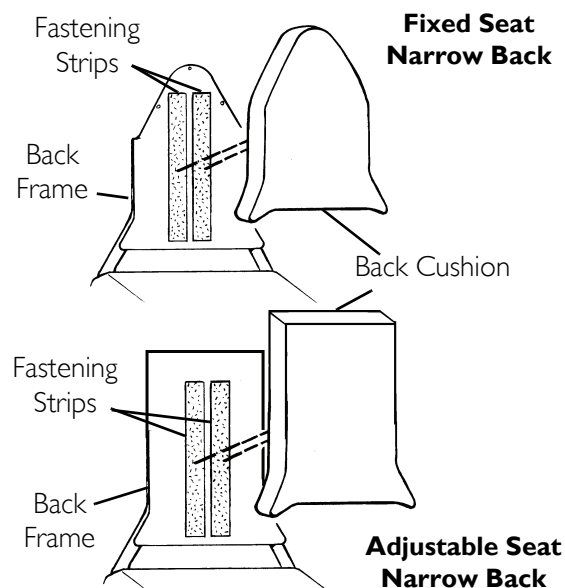

FIGURE 8.13 Replacing Narrow Back Upholstery

SECTION 9—OPTIONS

⚠ WARNING

After any adjustments, repair or service and before use, make sure all attaching hardware is tightened securely - otherwise injury or damage may result.

Installing Rear Safety Light

⚠ WARNING

Operation of the handcycle is subject to all traffic rules and regulations. (This may include the use of a safety light and reflectors for dusk/night riding.)

NOTE: For this procedure, refer to FIGURE 9.1.

Batteries

1. Remove the lens cover.
2. Insert the AAA batteries with correct polarity (+ or -).
3. Reinstall lens cover.

Mounting the Safety Light

1. Remove the set screw from the clamp on the safety light.
2. Position the clamp onto the rear seat post.
3. Install the set screw into the clamp and tighten securely.

Operating the Safety Light

1. Press GREY button to turn safety light on/off.
2. Remove lens cover and slide switch back and forth for pulse or constant mode.

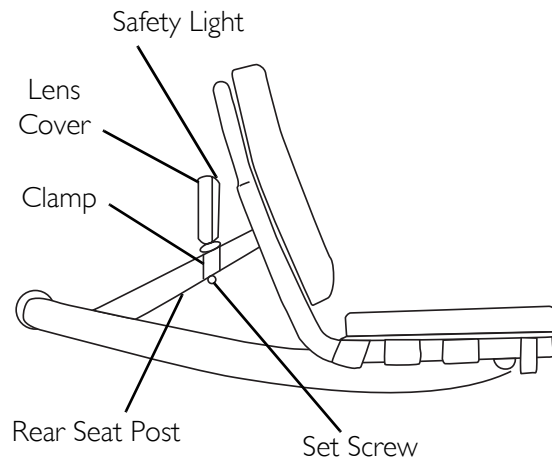

NOTE: Rear wheels removed for clarity.

FIGURE 9.1 Installing Rear Safety Light

Installing the Water Bottle

NOTE: For this procedure, refer to FIGURE 9.2.

1. Secure the water bottle mounting tube to the seat frame using the hardware provided.

NOTE: Make sure that the water bottle mounting bracket mounting holes are facing downward.

2. Attach the water bottle mounting bracket to the mounting tube using the hardware provided.
3. Push water bottle into mounting bracket until secure.

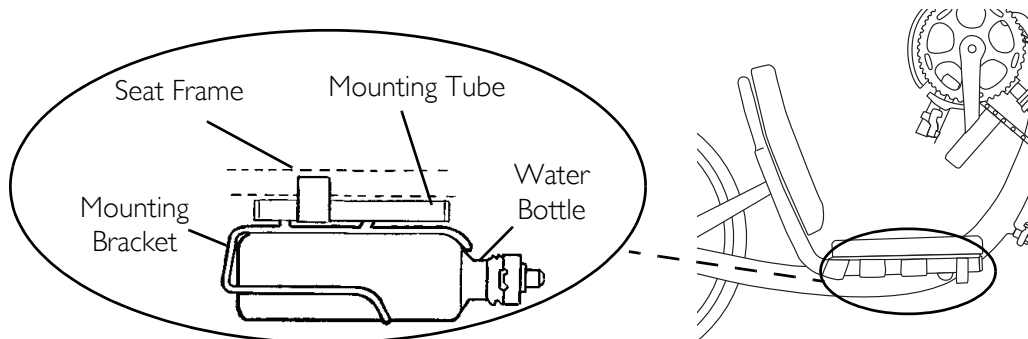

FIGURE 9.2 Installing the Water Bottle

Installing/Using the Tow Bar

NOTE: For this procedure, refer to FIGURE 9.3.

NOTE: The tow bar will not work with wheelchairs with swingaway front riggings. Only rigid wheelchairs with a tubular style footrest can be towed using the tow bar.

1. Remove the two set screws on each mounting bracket.
2. Position the mounting brackets around the handcycle rear frame.

NOTE: Make sure that the tow bar is centered on the handcycle rear frame.

3. Using two set screws for each mounting bracket, secure the mounting brackets to the handcycle rear frame.
4. Secure the tow bar to the handcycle with the mounting brackets and set screws.
5. Secure the wheelchair to the tow bar with the fastening strips provided.

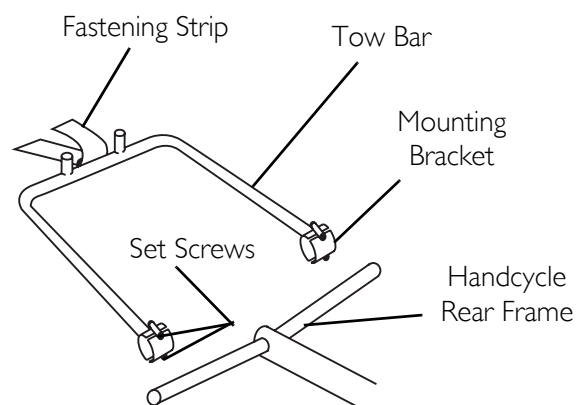

FIGURE 9.3 Installing/Using the Tow Bar

Installing the Draft Bumper

⚠ WARNING

DO NOT use if draft bumper extends past rear wheels. If draft bumper extends past the rear wheels, contact dealer.

NOTE: For this procedure, refer to FIGURE 9.4.

NOTE: The draft bumper can not be installed if the tow bar is installed.

1. Remove the four set screws on each mounting bracket.
2. Position the mounting brackets around the handcycle rear frame.

NOTE: Make sure that the draft bumper is centered on the handcycle rear frame.

3. Using four set screws for each mounting bracket, secure the mounting brackets to the handcycle rear frame.

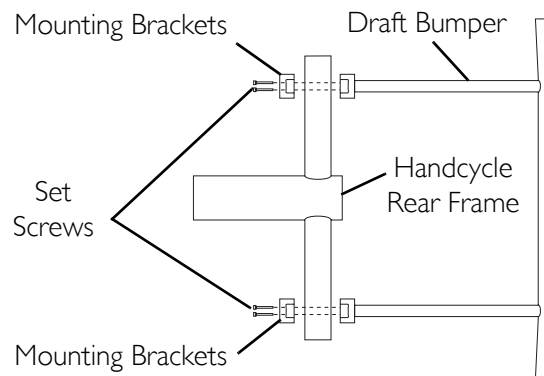

FIGURE 9.4 Installing the Draft Bumper

Installing the Safety Flag

NOTE: For this procedure, refer to FIGURE 9.5.

1. Mount safety flag in holder secured to back tube on bike frame.

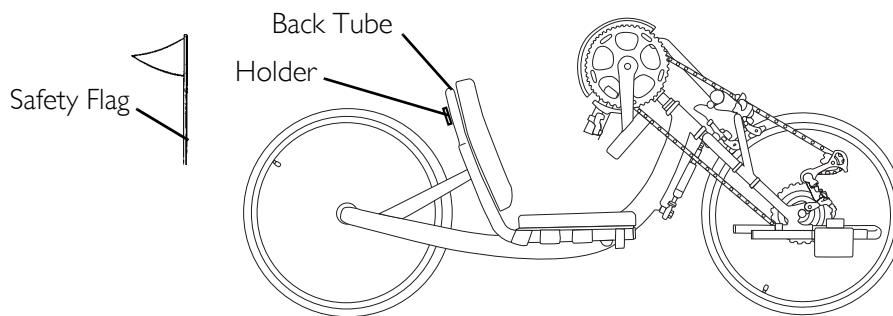

FIGURE 9.5 Installing the Safety Flag

Using Safety Helmet

NOTE: For this procedure, refer to FIGURE 9.6.

1. Secure helmet using the chin strap.
2. Ensure proper fit.

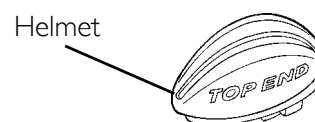

FIGURE 9.6 Using Safety Helmet

Installing Seat Positioning Strap

NOTE: For this procedure, refer to FIGURE 9.7.

1. Secure seat positioning strap to back canes using hardware provided.

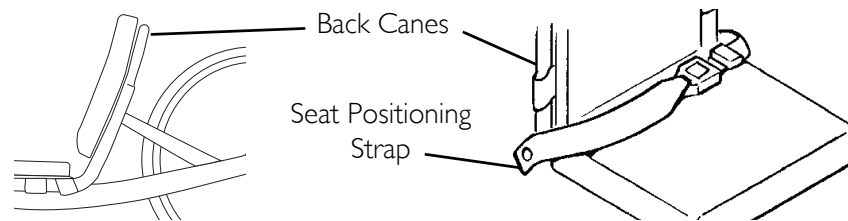

FIGURE 9.7 Installing Seat Positioning Strap

Installing the Computer

NOTE: For this procedure, refer to FIGURE 9.8.

1. Install metal plug onto spoke of front wheel approximately 2 inches from wheel rim.
2. Align metal plug with fork assembly.
3. Secure sensor to fork using hardware provided.

NOTE: Slot in sensor MUST align with metal plug for mileage, etc. to be registered on the computer.

4. Remove one of the chain guard screws and attach the computer mounting bracket.
5. Snap computer into mounting bracket.

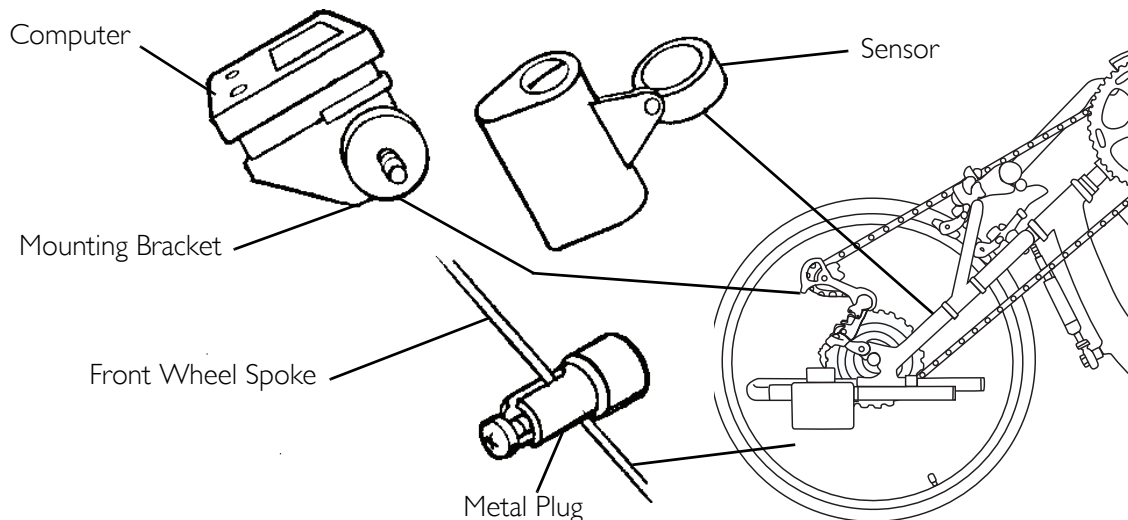

FIGURE 9.8 Installing the Computer

Installing Hand Crank Handles

NOTE: For this procedure, refer to FIGURE 9.9.

Horizontal Handles/Delrin Handles

1. Secure handle to hand crank with the screw (Detail "A").
2. Remove the screw to remove handle from handcrank.

Vertical Handles

1. Position handle onto crank (Detail "B").
2. Tighten set screw to secure handle to crank.
3. Reverse STEPS 1-2 to remove handle.

Tri-pin Quad Handles

1. Remove/install tri-pin quad handles. Refer to [Vertical Handles](#) on page 64
2. Loosen socket screws to adjust handle position (Detail "C").
3. Tighten socket screws to secure handles in desired position.

V or S Crank Handles

Replacement/installation of V or S crank handles should be done by a qualified technician.

DETAIL "A" - HORIZONTAL HANDLES/DELTRIN HANDLES

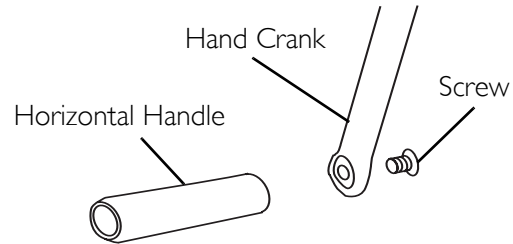

DETAIL "B" - VERTICAL HANDLES

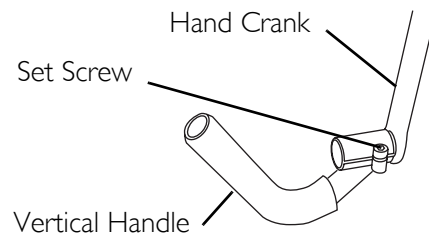

DETAIL "C" - TRI-PIN HANDLES

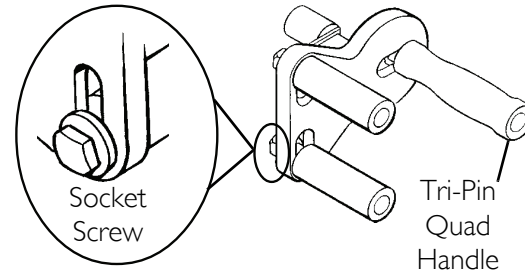

FIGURE 9.9 Installing Hand Crank Handles

Installing V/S Crankarm Handles

For Models Made Before 7/12/07

⚠ WARNING

**Failure to install handle assembly properly could result in injury.
It is recommended to inspect this assembly prior to and after each use.**

NOTE: For this procedure, refer to FIGURE 9.10 on page 65.

1. Secure the handle to the crankarm housing using the bolt, spacer, and two bearings.

2. Firmly tighten the bolt.

NOTE: Handle should spin freely with minimal play. If handle does not spin freely make sure the spacer is firmly in place. If handle still does not spin freely, contact Invacare.

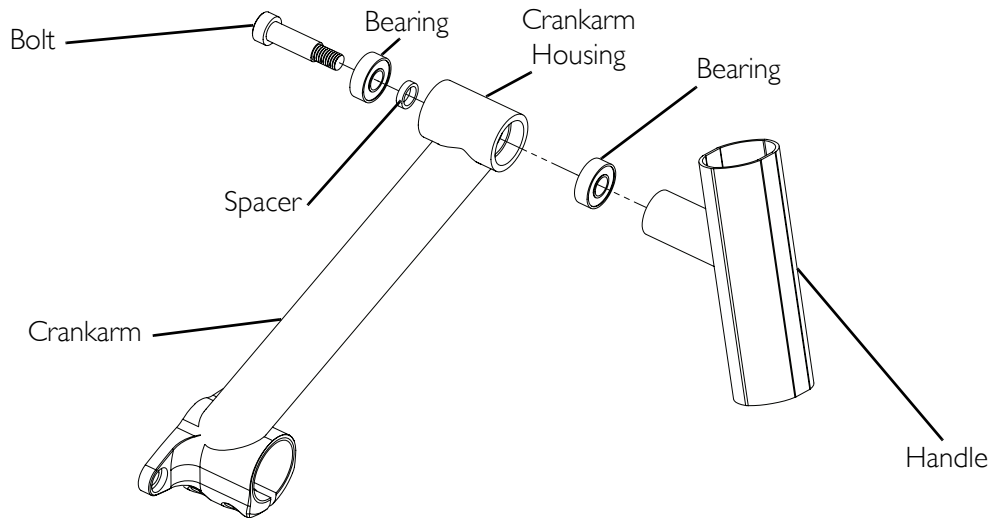

FIGURE 9.10 Installing V/S Crankarm Handles - For Models Made Before 7/12/07

For Models Made After 7/12/07

⚠ WARNING

Failure to install handle assembly properly could result in injury. It is recommended to inspect this assembly prior to and after each use.

NOTE: For this procedure, refer to FIGURE 9.11.

1. Secure the handle to the crankarm housing using the set screw and locknut.

NOTE: Use the right handle, the handle with a mounting post, with the right crankarm and left with left crankarm. The right crankarm has a flange at the base of the crankarm. The left crankarm does not.

2. Firmly tighten the locknut.

NOTE: Handle should spin freely with minimal play. If handle does not spin freely, contact Invacare.

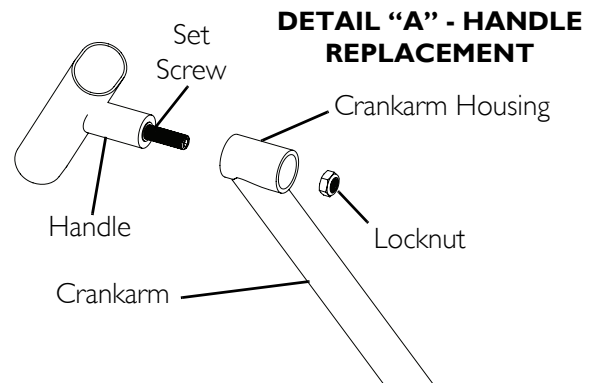

DETAIL "B" - CRANKARM ORIENTATION

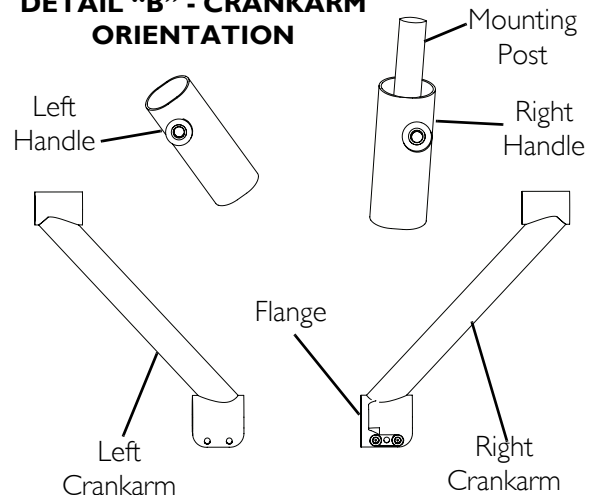

FIGURE 9.11 Installing V/S Crankarm Handles - For Models Made After 7/12/07

Installing Gloves

NOTE: For this procedure, refer to FIGURE 9.12 on page 66.

1. Wrap palm loop around horizontal handle (using top slot only) and secure to glove.
2. Run glove loop through bottom slot on palm and over back of hand until tight. Secure glove loop to back of glove.
3. Reattach glove strips to back of glove.



FIGURE 9.12 Installing Gloves

Mountain Drive Transmission Option

⚠ WARNING

DO NOT shift the mountain drive transmission option under load (i.e. using a high gear to start the handcycle in motion or to climb a hill, etc.). Shifting the mountain drive transmission option under load will damage the internal workings of the mountain drive option and will void the warranty.

NOTE: For this procedure, refer to FIGURE 9.13 on page 66.

Switching to Mountain Drive Transmission Option

1. Perform one of the following:
 - Switching Mountain Drive Transmission Option On - Push in the gear shift button in the middle of the right side of the hand crank while the option is under no load.
 - Switching Mountain Drive Transmission Option Off - Push the gear shift button on the left side of the hand crank in while the option is under no load.

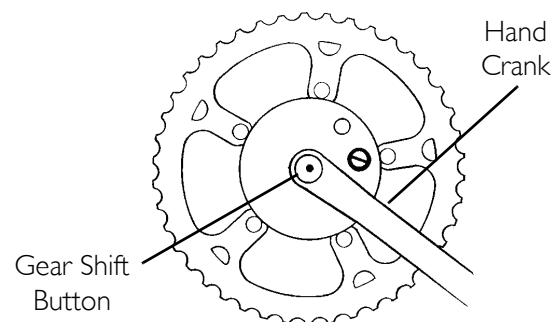

FIGURE 9.13 Mountain Drive Transmission Option

Mountain Drive Transmission Option Maintenance

The mountain drive transmission option should be maintained by a qualified technician according to the manufacturer's instructions included with the handcycle.

Using the Travel Ready Option

NOTE: For this procedure, refer to FIGURE 9.14 on page 67.

NOTE: This procedure is for Top End XLT Pro, Gold, and Top End Force models only.

The travel ready option allows the handcycle to be quickly and easily disassembled for travel.

NOTE: Reverse the steps below to reassemble the handcycle.

1. Remove the rear wheels. Refer to Installing/Adjusting the Rear Wheel and Quick-Release Axles on page 42.
2. Remove the camber bar. Refer to Removing/Installing the Camber Bar on page 67.
3. Remove the footrests. Refer to Replacing/Adjusting the Footrest and Leg Guard on page 32.
4. Remove the fork and front wheel. Refer to Removing/Installing the Fork - Travel Ready XLT PRO Equipped with Road Crown Compensator on page 68 or Removing/Installing the Fork - XLT Gold, and Top End Force Equipped with Steering Dampener on page 69.

Removing/Installing the Camber Bar

NOTE: For this procedure, refer to FIGURE 9.14 on page 67.

NOTE: To install the camber bar, reverse the steps below.

1. Perform one of the following
 - Adjustable Angle Seat on XLT Gold - Seat support tube does not mount to camber bar. Proceed to STEP 2.
 - Adjustable Angle Seats Except XLT Gold - Loosen, but DO NOT remove the two hex screws securing the seat support clamps to the camber bar.
2. Loosen, but DO NOT remove the two hex screws securing the frame clamps to the camber bar.
3. Slide the camber bar through the clamps.

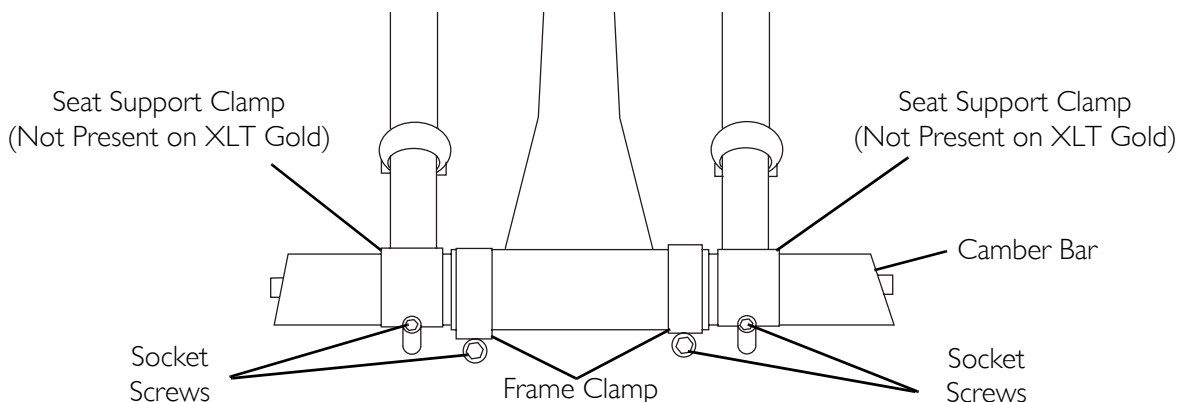

FIGURE 9.14 Removing/Installing the Camber Bar

Removing/Installing the Fork - Travel Ready XLT PRO Equipped with Road Crown Compensator

NOTE: For this procedure, refer to FIGURE 9.15 on page 69.

Removing the Fork

1. Remove the nut securing the road crown compensator to the fork.
2. Remove the road crown compensator from the fork bolt.
3. Remove the two socket screws from each fork clamp.
4. Remove the plate from the top of the fork.
5. Remove the fork from the frame.
6. Remove the front wheel from the fork. Refer to Removing the Front Wheel on page 70.

Installing the Fork

1. Position the fork onto the frame.
2. Position the plate on to the fork.
3. Secure the plate to the frame using the two clamps and four Socket screws.
4. Position the road crown compensator onto the fork bolt.
5. Secure the road crown compensator to the fork bolt using the nut.
6. Install the front wheel. Refer to Installing the Front Wheel on page 71.
7. Test drive handcycle, if handcycle pulls to the left or right adjust the road crown compensator. Refer to Adjusting Road Crown Compensator on page 51.

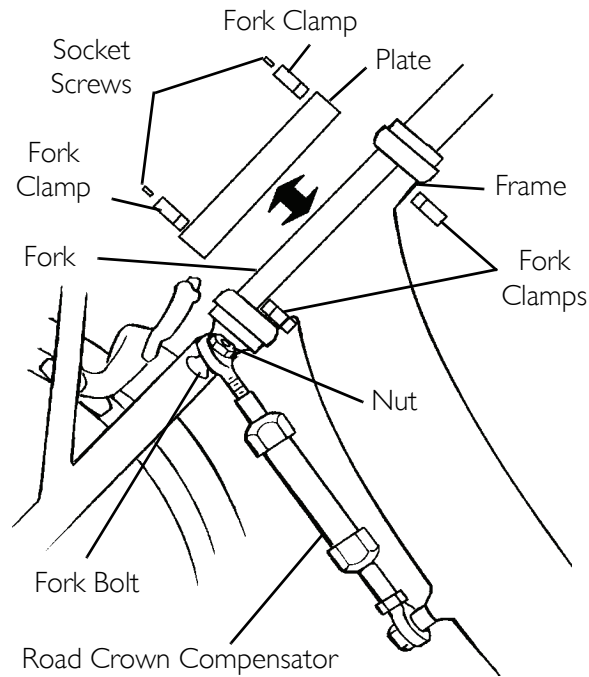

FIGURE 9.15 Removing/Installing the Fork - Travel Ready XLT PRO Equipped with Road Crown Compensator

Removing/Installing the Fork - XLT Gold, and Top End Force Equipped with Steering Dampener

NOTE: For this procedure, refer to FIGURE 9.16 on page 70.

Removing the Fork

1. Remove the locknut securing the steering dampener to the dampener clamp (Detail "A").
2. Remove the two socket screws securing the dampener clamp to the handcycle frame.
3. Remove the dampener clamp from the handcycle frame and the lower threaded post of the steering dampener.
4. Remove the two socket screws from the fork clamp.
5. Remove the plate from the top of the fork.
6. Remove the fork from the frame.
7. Remove the front wheel from the fork. Refer to [Removing the Front Wheel](#) on page 70.

Installing the Fork

1. Position the fork onto the frame.
2. Position the plate on to the fork.

3. Using the fork clamp and two socket screws, secure the bottom of the plate to the frame.
4. While inserting the lower threaded post into the tab, position the dampener clamp around the handcycle frame.
5. Using two socket screws, loosely secure the dampener clamp to the handcycle frame.
6. Using a locknut, secure the steering dampener to the dampener clamp.
7. Install the front wheel. Refer to [Installing the Front Wheel](#) on page 71.
8. Ensuring the front wheel and dampener clamp are inline with the handcycle frame, securely tighten the two socket screws securing the dampener clamp to the handcycle frame.
9. Test drive handcycle, if handcycle pulls to the left or right adjust the steering dampener. Refer to [Adjusting Steering Dampener](#) on page 52.

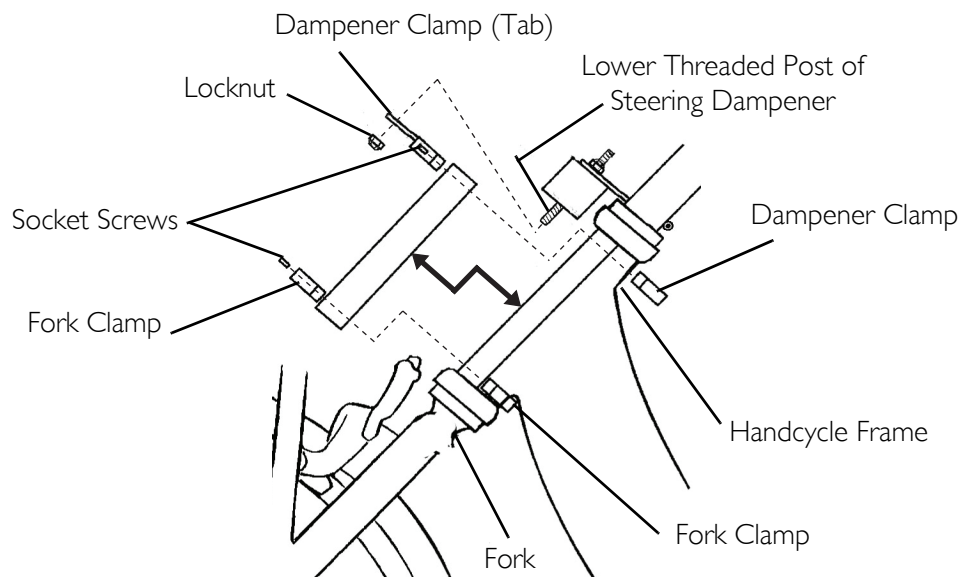

FIGURE 9.16 Removing/Installing the Fork - XLT Gold, and Top End Force Equipped with Steering Dampener

Removing/Installing the Front Wheel - XLT Gold, XLT Pro and XLT with Speed Cassette Chain

NOTE: For this procedure, refer to FIGURE 9.17 on page 71.

Removing the Front Wheel

1. Open the quick-release lever securing the front wheel to the fork (Detail "A").
2. Loosen the knob on the opposite side of the quick-release lever.
3. Remove the wheel from the fork.
4. Remove the chain from the front wheel.

Installing the Front Wheel

NOTE: For ease of installation, secure handcycle frame approximately 6 inches from the ground or seek assistance.

1. Loop the chain over the front wheel sprocket.
2. Position the front wheel sprocket into the fork slots.
3. Tighten the knob on the opposite side of the quick-release lever.
4. Secure the wheel to the fork with the quick-release lever.

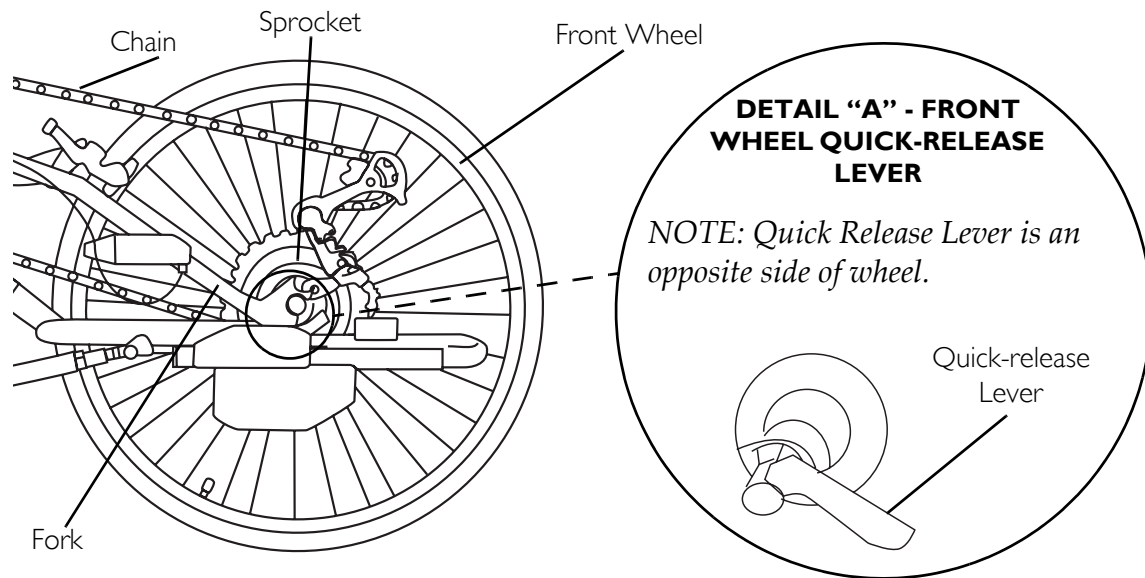

FIGURE 9.17 Removing/Installing the Front Wheel - XLT Gold, XLT Pro and XLT with Speed Cassette Chain

Assembling/Using/Adjusting the Handcycle Rack

NOTE: For this procedure, refer to FIGURE 9.18 on page 72.

Assembling the Handcycle Rack

1. Position the receiver with the bracket facing up.
2. Position the rear wheel bar with the wheel brackets facing up.
3. Remove the two large mounting bolts and locknuts from the receiver and set aside.
4. Remove the two small mounting bolts and locknuts from the receiver bracket and set aside.
5. Secure the wheel tray to the receiver with the two large mounting bolts and locknuts.
6. Using two small mounting bolts and locknuts, secure the receiver bracket to the wheel tray.
7. Remove the two mounting bolts and locknuts from the rear wheel bar and set aside.

8. Using two mounting bolts and locknuts, secure the rear wheel bar to the wheel tray.
9. Install the receiver onto the trailer hitch of the vehicle, according to the vehicle manufacturer's instructions.

Using the Handcycle Rack

1. Position the handcycle on the rack with the front wheel in the wheel tray bracket.
2. Adjust the handcycle rack so the wheel tray bracket sits against the front wheel and the rear wheel bar brackets sit against the rear wheels. Refer to [Adjusting the Handcycle Rack](#) on page 73.
3. Secure the front wheel to the wheel tray bracket using the strap provided.
4. Secure the rear wheels to the rear wheel bar using the straps provided.

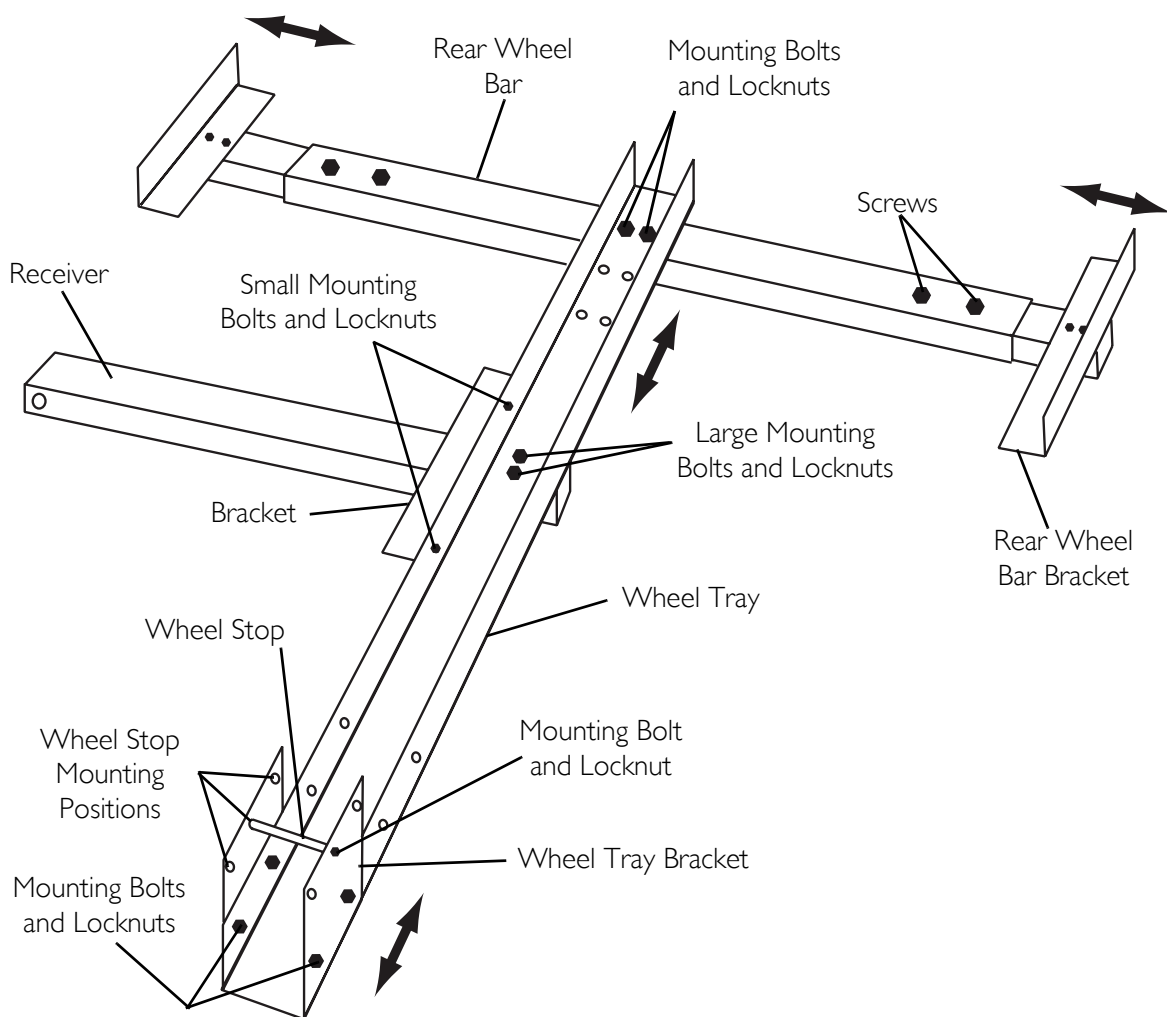

FIGURE 9.18 Assembling/Using/Adjusting the Handcycle Rack

Adjusting the Handcycle Rack

Wheel Tray Bracket

NOTE: To properly secure the handcycle, the wheel tray bracket should be adjusted to sit against the front wheel.

1. Remove the four mounting bolts and locknuts securing the wheel tray bracket to the wheel tray.
2. Position the wheel tray bracket in the desired position.
3. Secure the wheel tray bracket to the wheel tray with the four mounting bolts and locknuts.
4. If necessary, the wheel stop may be adjusted to one of three positions to sit against the front wheel. To adjust the wheel stop, perform the following steps:
 - A. Remove the mounting bolt and locknut securing the wheel stop to the wheel tray bracket.
 - B. Position the wheel stop in the desired mounting position.
 - C. Secure the wheel stop to the wheel tray bracket with the mounting bolt and locknut.

Rear Wheel Bar Brackets

NOTE: To properly secure the handcycle, the rear wheel bar brackets should be adjusted to sit against the rear wheels.

1. Loosen the two screws securing the rear wheel bar bracket to the rear wheel bar.
2. Adjust the rear wheel bar bracket in/out until they sit against the rear wheel.
3. Secure the rear wheel bar bracket to the rear wheel bar with the two screws.
4. Repeat STEPS 1-3 for the opposite side if necessary.

Rear Wheel Bar

NOTE: To properly secure the handcycle, the rear wheel bar should be adjusted so the rear wheels sit in the rear wheel bar brackets.

1. Remove the two mounting bolts and locknuts securing the rear wheel bar to the wheel tray.
2. Position the rear wheel bar to one of three mounting positions on the wheel tray.
3. Secure the rear wheel bar to the wheel tray with the two mounting bolts and locknuts.

Using the Alignment Gauge

NOTE: For this procedure, refer to FIGURE 9.19.

NOTE: The alignment gauge is used to determine toe in/toe out. Refer to [Determining/Adjusting Toe In/Toe Out](#) on page 44 for more information.

1. Inflate all pneumatic tires to recommended tire pressures (listed on the sidewall of the tire).
2. Place the handcycle and alignment gauge on a flat surface.
3. Position the alignment gauge near the rear of the rear tires.
4. Loosen the height adjustment screw.
5. Raise/lower the alignment bar so the bar is approximately 12 inches from the ground/floor.
6. Tighten the height adjustment screw.
7. Loosen the alignment screw.
8. Position the alignment gauge between the rear of the rear tires.
9. Adjust the alignment bar so the alignment gauge fits snugly between the rear of the rear tires.
10. Tighten the alignment screw to secure the alignment bar position.
11. Position the alignment gauge at the front of the rear tires.
12. Examine the gauge. Perform one of the following:
 - A. Alignment Gauge Fits Snugly Between the Front of the Rear Tires - Wheels are aligned. No toe in/toe out adjustment is needed.
 - B. There is Extra Space Between the Alignment Gauge and Rear Tires - The tires have a toe out condition. Refer to [Adjusting Toe In/Toe Out](#) on page 45.
 - C. Alignment Gauge Does Not Fit Between Rear Tires - The tires have a toe in condition. Refer to [Adjusting Toe In/Toe Out](#) on page 45.

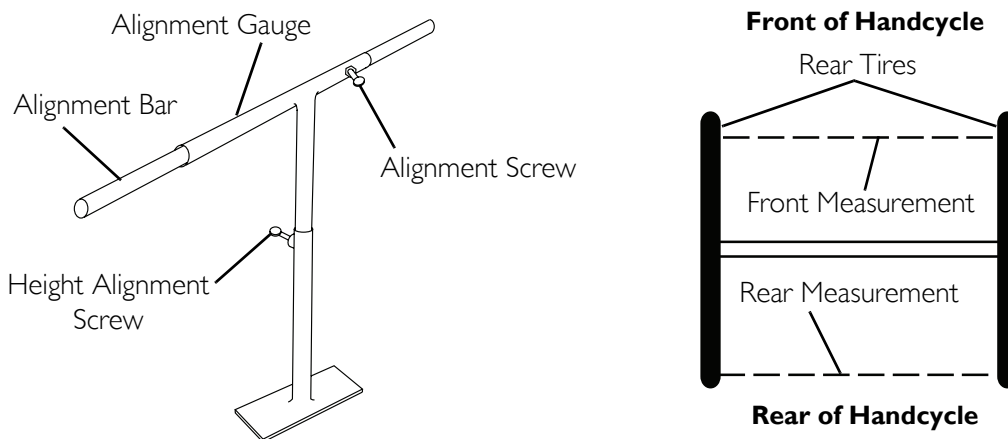

FIGURE 9.19 Using the Alignment Gauge

LIMITED WARRANTY

PLEASE NOTE: THE WARRANTY BELOW HAS BEEN DRAFTED TO COMPLY WITH FEDERAL LAW APPLICABLE TO PRODUCTS MANUFACTURED AFTER JULY 4, 1975.

This warranty is extended only to the original purchaser/user of our products.

This warranty gives you specific legal rights and you may also have other legal rights which vary from state to state.

Invacare warrants the frame to be free from defects in materials and workmanship for a period of three years from date of purchase; distributed parts and components including compensators, forks, upholstery and miscellaneous bicycle components are warranted for a period of one year from the date of purchase; except all tires, tubes, push handles grips, foam parts, plastic coated parts, bushings, bearings and cables which are not warranted. The Mountain Drive Option is not warranted. If within such warranty period any such product shall be proven to be defective, such product shall be repaired or replaced, at Invacare's option. This warranty does not include any labor or shipping charges incurred in replacement part installation or repair of any such product. Invacare's sole obligation and your exclusive remedy under this warranty shall be limited to such repair and/or replacement.

This warranty pertains to the Top End Series Only!

For warranty service, please contact the dealer from whom you purchased your Invacare product. In the event you do not receive satisfactory warranty service, please write directly to Invacare at the address at the bottom of the back cover. Provide dealer's name, address, date of purchase, indicate nature of the defect and, if the product is serialized, indicate the serial number. **DO NOT** return products to our factory without our prior consent.

LIMITATIONS AND EXCLUSIONS: THE FOREGOING WARRANTY SHALL NOT APPLY TO SERIAL NUMBERED PRODUCTS IF THE SERIAL NUMBER HAS BEEN REMOVED OR DEFACED, PRODUCTS SUBJECTED TO NEGLIGENCE, ACCIDENT, IMPROPER OPERATION, MAINTENANCE OR STORAGE, COMMERCIAL OR INSTITUTIONAL USE, PRODUCTS MODIFIED WITHOUT INVACARE'S EXPRESS WRITTEN CONSENT INCLUDING, BUT NOT LIMITED TO, MODIFICATION THROUGH THE USE OF UNAUTHORIZED PARTS OR ATTACHMENTS; PRODUCTS DAMAGED BY REASON OF REPAIRS MADE TO ANY COMPONENT WITHOUT THE SPECIFIC CONSENT OF INVACARE, OR TO A PRODUCT DAMAGED BY CIRCUMSTANCES BEYOND INVACARE'S CONTROL, AND SUCH EVALUATION WILL BE SOLELY DETERMINED BY INVACARE. THE WARRANTY SHALL NOT APPLY TO PROBLEMS ARISING FROM NORMAL WEAR OR FAILURE TO ADHERE TO THESE INSTRUCTIONS.

THE FOREGOING EXPRESS WARRANTY IS EXCLUSIVE AND IN LIEU OF ANY OTHER WARRANTIES WHATSOEVER, WHETHER EXPRESS OR IMPLIED, INCLUDING THE IMPLIED WARRANTIES OF MERCHANTABILITY AND FITNESS FOR A PARTICULAR PURPOSE, AND THE SOLE REMEDY FOR VIOLATIONS OF ANY WARRANTY WHATSOEVER, SHALL BE LIMITED TO REPAIR OR REPLACEMENT OF THE DEFECTIVE PRODUCT PURSUANT TO THE TERMS CONTAINED HEREIN. THE APPLICATION OF ANY IMPLIED WARRANTY WHATSOEVER SHALL NOT EXTEND BEYOND THE DURATION OF THE EXPRESS WARRANTY PROVIDED HEREIN. INVACARE SHALL NOT BE LIABLE FOR ANY CONSEQUENTIAL OR INCIDENTAL DAMAGES WHATSOEVER.

THIS WARRANTY SHALL BE EXTENDED TO COMPLY WITH STATE/PROVINCIAL LAWS AND REQUIREMENTS.



Yes, you can.[®]

Invacare Corporation www.invacare.com

USA

One Invacare Way
Elyria, Ohio USA
44036-2125
800-333-6900

Canada

570 Matheson Blvd E Unit 8
Mississauga Ontario
L4Z 4G4 Canada
800-668-5324

All rights reserved. Trademarks are identified by the symbols [™] and [®]. All trademarks are owned by or licensed to Invacare Corporation unless otherwise noted.

Shimano, Nexus, and Ultegra are registered trademarks of Shimano Inc. 3-in-1 and WD-40 are registered trademarks of the WD-40 Company. Delrin and Teflon are registered trademarks of E.I. DuPont De Nemours and Company.

Loctite 242 is a trademark of the Loctite Corporation.

© 2007 Invacare Corporation

Part No 1114850

Rev D- 07/07

Free Manuals Download Website

<http://myh66.com>

<http://usermanuals.us>

<http://www.somanuals.com>

<http://www.4manuals.cc>

<http://www.manual-lib.com>

<http://www.404manual.com>

<http://www.luxmanual.com>

<http://aubethermostatmanual.com>

Golf course search by state

<http://golfingnear.com>

Email search by domain

<http://emailbydomain.com>

Auto manuals search

<http://auto.somanuals.com>

TV manuals search

<http://tv.somanuals.com>